

# Operating Manual

---

## pDDL900

1W Dual Frequency 900MHz/2.4GHz Digital Data Link

Revision 0.35, April 11, 2017

---

 Microhard Systems Inc.

[www.microhardcorp.com](http://www.microhardcorp.com)

## Warranty

Microhard Systems Inc. warrants that each product will be free of defects in material and workmanship for a period of one (1) year for its products. The warranty commences on the date the product is shipped by Microhard Systems Inc. Microhard Systems Inc.'s sole liability and responsibility under this warranty is to repair or replace any product which is returned to it by the Buyer and which Microhard Systems Inc. determines does not conform to the warranty. Product returned to Microhard Systems Inc. for warranty service will be shipped to Microhard Systems Inc. at Buyer's expense and will be returned to Buyer at Microhard Systems Inc.'s expense. In no event shall Microhard Systems Inc. be responsible under this warranty for any defect which is caused by negligence, misuse or mistreatment of a product or for any unit which has been altered or modified in any way. The warranty of replacement shall terminate with the warranty of the product.

## Warranty Disclaims

Microhard Systems Inc. makes no warranties of any nature of kind, expressed or implied, with respect to the hardware, software, and/or products and hereby disclaims any and all such warranties, including but not limited to warranty of non-infringement, implied warranties of merchantability for a particular purpose, any interruption or loss of the hardware, software, and/or product, any delay in providing the hardware, software, and/or product or correcting any defect in the hardware, software, and/or product, or any other warranty. The Purchaser represents and warrants that Microhard Systems Inc. has not made any such warranties to the Purchaser or its agents MICROHARD SYSTEMS INC. EXPRESS WARRANTY TO BUYER CONSTITUTES MICROHARD SYSTEMS INC. SOLE LIABILITY AND THE BUYER'S SOLE REMEDIES. EXCEPT AS THUS PROVIDED, MICROHARD SYSTEMS INC. DISCLAIMS ALL WARRANTIES, EXPRESS OR IMPLIED, INCLUDING ANY WARRANTY OF MERCHANTABILITY OR FITNESS FOR A PARTICULAR PROMISE.

**MICROHARD SYSTEMS INC. PRODUCTS ARE NOT DESIGNED OR INTENDED TO BE USED IN ANY LIFE SUPPORT RELATED DEVICE OR SYSTEM RELATED FUNCTIONS NOR AS PART OF ANY OTHER CRITICAL SYSTEM AND ARE GRANTED NO FUNCTIONAL WARRANTY.**

## Indemnification

The Purchaser shall indemnify Microhard Systems Inc. and its respective directors, officers, employees, successors and assigns including any subsidiaries, related corporations, or affiliates, shall be released and discharged from any and all manner of action, causes of action, liability, losses, damages, suits, dues, sums of money, expenses (including legal fees), general damages, special damages, including without limitation, claims for personal injuries, death or property damage related to the products sold hereunder, costs and demands of every and any kind and nature whatsoever at law.

IN NO EVENT WILL MICROHARD SYSTEMS INC. BE LIABLE FOR ANY INDIRECT, SPECIAL, CONSEQUENTIAL, INCIDENTAL, BUSINESS INTERRUPTION, CATASTROPHIC, PUNITIVE OR OTHER DAMAGES WHICH MAY BE CLAIMED TO ARISE IN CONNECTION WITH THE HARDWARE, REGARDLESS OF THE LEGAL THEORY BEHIND SUCH CLAIMS, WHETHER IN TORT, CONTRACT OR UNDER ANY APPLICABLE STATUTORY OR REGULATORY LAWS, RULES, REGULATIONS, EXECUTIVE OR ADMINISTRATIVE ORDERS OR DECLARATIONS OR OTHERWISE, EVEN IF MICROHARD SYSTEMS INC. HAS BEEN ADVISED OR OTHERWISE HAS KNOWLEDGE OF THE POSSIBILITY OF SUCH DAMAGES AND TAKES NO ACTION TO PREVENT OR MINIMIZE SUCH DAMAGES. IN THE EVENT THAT REGARDLESS OF THE WARRANTY DISCLAIMERS AND HOLD HARMLESS PROVISIONS INCLUDED ABOVE MICROHARD SYSTEMS INC. IS SOMEHOW HELD LIABLE OR RESPONSIBLE FOR ANY DAMAGE OR INJURY, MICROHARD SYSTEMS INC.'S LIABILITY FOR ANY DAMAGES SHALL NOT EXCEED THE PROFIT REALIZED BY MICROHARD SYSTEMS INC. ON THE SALE OR PROVISION OF THE HARDWARE TO THE CUSTOMER.

## Proprietary Rights

The Buyer hereby acknowledges that Microhard Systems Inc. has a proprietary interest and intellectual property rights in the Hardware, Software and/or Products. The Purchaser shall not (i) remove any copyright, trade secret, trademark or other evidence of Microhard Systems Inc.'s ownership or proprietary interest or confidentiality other proprietary notices contained on, or in, the Hardware, Software or Products, (ii) reproduce or modify any Hardware, Software or Products or make any copies thereof, (iii) reverse assemble, reverse engineer or decompile any Software or copy thereof in whole or in part, (iv) sell, transfer or otherwise make available to others the Hardware, Software, or Products or documentation thereof or any copy thereof, except in accordance with this Agreement.

## **pDDL900 Regulatory Requirements - PLEASE READ THIS SECTION CAREFULLY**



### **WARNING:**

To satisfy FCC/IC RF exposure requirements for mobile transmitting devices, a separation distance of 36 cm or more should be maintained between the antenna of this device and persons during device operation. To ensure compliance, operations at closer than this distance is not recommended. The antenna used for this transmitter must not be co-located in conjunction with any other antenna or transmitter.



### **WARNING:**

This device complies with part 15 of the FCC Rules. Operation is subject to the following two conditions: (1) This device may not cause harmful interference, and (2) this device must accept any interference received, including interference that may cause undesired operation.



### **WARNING:**

Changes or modifications not expressly approved by Microhard Systems Inc. could void the user's authority to operate the equipment. This device has been tested with UFL to Reverse Polarity SMA connectors with the antennas listed in Appendix A. When integrated in OEM products, fixed antennas require installation preventing end-users from replacing them with non-approved antennas. Antennas not listed in the tables must be tested to comply with FCC Section 15.203 (unique antenna connectors) and Section 15.247 (emissions).



### **WARNING:**

#### **MAXIMUM EIRP**

FCC Regulations allow up to 36 dBm equivalent isotropically radiated power (EIRP). Therefore, the sum of the transmitted power (in dBm), the cabling loss and the antenna gain cannot exceed 36 dBm.



### **WARNING:**

#### **EQUIPMENT LABELING**

The FCC and IC numbers depend on the model of the radio module. Do NOT use the Marketing Name of the product but the Model to distinguish the Certifications Numbers. This device has been modularly approved. The manufacturer, product name, and FCC and ISED identifiers of this product must appear on the outside label of the end-user equipment.



### **WARNING:**

This device complies with ISED license-exempt RSSs. Operation is subject to the following two conditions:

(1) This device may not cause interference; and (2) This device must accept any interference, including interference that may cause undesired operation of the device.

### **SAMPLE LABEL REQUIREMENT for Model: pDDL900:**

#### **Contains:**

**FCC ID: NS917PDDL900      IC: 3143A-17PDDL900**

**This device complies with Part 15 of the FCC Rules.  
Operation is subject to the following two conditions: (1) this device may not cause harmful interference, and (2) this device must accept any interference received including interference that may cause undesired operation.**

# pDDL900 Exigences Réglementaires



## WARNING:

Pour satisfaire aux exigences de la FCC/IC d'exposition RF pour la base et mobiles sur une distance de séparation de 36 cm ou plus doit être maintenue entre l'antenne de cet appareil et des personnes lors de fonctionnement du dispositif. Pour assurer la conformité des opérations au plus près que cette distance n'est pas recommandée. L'antenne utilisée pour ce transmetteur ne doit pas être co-localisés en conjonction avec toute autre antenne ou transmetteur.



## WARNING:

Son fonctionnement est soumis aux deux conditions suivantes : ( 1 ) ce dispositif ne doit pas causer d'interférences nuisibles et ( 2 ) cet appareil doit accepter toute interférence reçue, incluant les interférences qui peuvent provoquer un fonctionnement indésirable .



## WARNING:

Les changements ou modifications non expressément approuvés par Microhard Systems Inc. pourraient annuler l'autorité de l'utilisateur à utiliser l'équipement . Ce dispositif a été testé avec MCX et connecteurs SMA à polarité inverse sur les antennes répertoriées à l'annexe A Lorsqu'il est intégré dans les produits OEM , antennes fixes nécessitent une installation empêchant les utilisateurs finaux de les remplacer par des antennes non approuvées . Antennes ne figurant pas dans les tableaux doivent être testés pour se conformer à la Section 15.203 (connecteurs d'antenne uniques ) et à la Section 15.247 ( émissions ) .



## WARNING:

### MAXIMUM EIRP

Règlement FCC permettent jusqu'à 36 dBm puissance isotrope rayonnée équivalente (EIRP) . Par conséquent, la somme de la puissance émise ( en dBm ), la perte de câblage et le gain d'antenne ne peut pas dépasser 36 dBm.



## WARNING:

### ÉQUIPEMENT DE MARQUAGE

Les numéros FCC et IC dépendent du modèle du module radio . Ne pas utiliser le nom marketing du produit, mais le modèle de distinguer les numéros Certifications . Ce dispositif a été approuvé de façon modulaire . Le fabricant , nom du produit, et les identificateurs de la FCC et ISED de ce produit doivent figurer sur l'étiquette à l'extérieur de l'équipement de l'utilisateur final .



## WARNING:

Cet appareil est conforme aux CNR exempts de licence ISED . Son fonctionnement est soumis aux deux conditions suivantes : ( 1 ) Ce dispositif ne peut causer des interférences ; et ( 2 ) Ce dispositif doit accepter toute interférence , y compris les interférences qui peuvent causer un mauvais fonctionnement de l'appareil.

## SAMPLE LABEL REQUIREMENT for Model: pDDL900:

### Contains:

**FCC ID: NS917PDDL900      IC : 3143A-17PDDL900**

Cet appareil est conforme à la partie 15 des règles de la FCC.  
Son fonctionnement est soumis aux deux conditions suivantes :  
( 1 ) ce dispositif ne doit pas causer d'interférences nuisibles et  
( 2 ) cet appareil doit accepter toute interférence reçue, incluant les interférences qui peuvent provoquer un fonctionnement indésirable .

## Federal Communication Commission Interference Statement

This equipment has been tested and found to comply with the limits for a Class B digital device, pursuant to part 15 of the FCC Rules. These limits are designed to provide reasonable protection against harmful interference in a residential installation. This equipment generates, uses and can radiate radio frequency energy and, if not installed and used in accordance with the instructions, may cause harmful interference to radio communications. However, there is no guarantee that interference will not occur in a particular installation. If this equipment does cause harmful interference to radio or television reception, which can be determined by turning the equipment off and on, the user is encouraged to try to correct the interference by one or more of the following measures:

- Reorient or relocate the receiving antenna.
- Increase the separation between the equipment and receiver.
- Connect the equipment into an outlet on a circuit different from that to which the receiver is connected.
- Consult the dealer or an experienced radio/TV technician for help.

## RF exposure Statement

The equipment complies with FCC/IC radiation exposure limits set forth for an uncontrolled environment. This equipment should be installed and operated with minimum distance 36cm between the radiator and your body.

## End Product Labeling

The Final end product must be labeled in a visible area with the following: **“Contains FCC ID: NS917PDDL900, IC: 3143A-17PDDL900”**.

The end product that integrated with this module must be tested to comply with unintentional radiators pursuant to FCC Part 15B and IC ICES-003.

## IMPORTANT NOTE

In the event that these condition can not be met (for example certain laptop configurations or co-location with another transmitter), then the FCC/IC authorization is no longer considered valid and FCC ID/IC can not be used on the final product. In these circumstances, the OEM integrator will be responsible for re-evaluating the end product (including the transmitter) and obtaining a separate FCC/IC authorization.

## NOTE IMPORTANTE

Dans le cas où ces conditions ne peuvent être respectées (par exemple certaines configurations d'ordinateurs portables ou de co-implantation avec un autre émetteur), l'autorisation de la FCC / IC n'est plus considéré comme valide et la FCC ID / IC ne peut pas être utilisé sur le produit final. Dans ces circonstances, l'intégrateur OEM sera responsable de réévaluer le produit final (y compris l'émetteur) et l'obtention d'une autorisation distincte de la FCC / IC.

## Co-Location with Cellular Modems

FCC: The maximum calculated MPE ratio for the EUT with 2.5 dBi dipole antenna is 0.398 (evaluated at 36 cm), this configuration can be co-located with other antennas provided the sum of the MPE ratios for all the other simultaneous transmitting antennas incorporated in a host device is  $\leq 1.0 - 0.398 \leq 0.602$ . The following co-location were evaluated for mobile configurations:

Innovation, Science and Economic Development Canada: The maximum calculated MPE ratio for the EUT with 2.5 dBi dipole antenna is 0.398 (evaluated at 36 cm), this configuration can be co-located with other antennas provided the sum of the MPE ratios for all the other simultaneous transmitting antennas incorporated in a host device is  $\leq 1.0 - 0.398 \leq 0.602$ . The following co-location were evaluated for mobile configurations:

- 1) EUT with 2.5 dBi dipole antenna co-located with Data Card Module  
(FCC ID RI7LN930, IC: 5131A-LN930)
- 2) EUT with 2.5 dBi dipole antenna co- located with LTE Data Transmitter Module  
( FCC ID R5QTOBYL201 , IC: 8595B-TOBYL201 )
- 3) EUT with 2.5 dBi dipole antenna co- located with GSM/UMTS/LTE Data Module  
( FCC ID RI7LE910NAV2, IC: 5131A-LE910NAV2 )
- 4) EUT with 2.5 dBi dipole antenna co- located with LTE Data Module  
  
( FCC ID SRQ-ME3630)

## Co - localisation avec Cellular Modem

FCC : Le maximum calculé rapport EMT pour l'EST avec antenne dipôle 2.5 dBi est de 0,398 (évalué à 36 cm), cette configuration peut être co- située avec d'autres antennes à condition que la somme des rapports MPE pour tous les autres antennes de transmission simultanées incorporés dans un dispositif hôte est  $< 1,0 - 0,398 < 0,602$  . Le co- emplacement suivant ont été évalués pour les configurations mobiles :

Innovation, Sciences et Développement économique Canada: Le maximum calculé rapport EMT pour l'EST avec antenne dipôle 2.5 dBi est de 0,398 (évalué à 36 cm), cette configuration peut être co- située avec d'autres antennes à condition que la somme des rapports MPE pour tous les autres antennes de transmission simultanées incorporés dans un dispositif hôte est  $\leq 1.0 - 0.398 \leq 0.602$ . Le co- emplacement suivant ont été évalués pour les configurations mobiles :

- 1 ) EUT avec 2.5 dBi antenne dipôle co-localisé avec module de carte de données  
( FCC ID RI7LN930 , IC : 5131A - LN930)
- 2 ) EUT avec 2.5 dBi antenne dipôle co- localisé avec LTE données Module émetteur  
( FCC ID R5QTOBYL201 , IC : 8595B-TOBYL201 )
- 3 ) EUT avec 2.5 dBi antenne dipôle situé coopération avec les réseaux GSM / UMTS / LTE du module de données ( FCC ID RI7LE910NAV2, IC : 5131A-LE910NAV2 )
- 4 ) EUT avec 2.5 dBi antenne dipôle co- localisé avec LTE données Module émetteur  
( FCC ID SRQ-ME3630)

# Contents

Warranty .....	ii
Proprietary Rights .....	ii
pDDL900 Regulatory Requirements .....	iii
pDDL900 Exigences Réglementaires .....	iv
Co-Location Instructions .....	vi
<b>2. GENERAL .....</b>	<b>1</b>
2.0 PRODUCT OVERVIEW .....	1
2.1 OUTPUT POWER LEVEL.....	2
<b>3. INSTALLATION.....</b>	<b>3</b>
3.0 OVERVIEW .....	3
3.1 ESTIMATING THE GAIN MARGIN .....	3
3.2 ANTENNAS AND CABLING.....	5
3.2.1 Internal Cabling .....	5
3.2.2 Installing External Cables, Antennas and Lightning Arrestors.....	6





# 2. General

---

## 2.0 Product Overview

The pDDL900 is a high-performance embedded wireless data transceiver. Operating in the 902 - 928 MHz and 2400 – 2483.5 MHz ISM band, this frequency-hopping spread-spectrum module is capable of providing reliable wireless data transfer between almost any type of equipment which uses an asynchronous serial interface. The small-size and superior RF performance of this module make it ideal for many applications.

While a pair of pDDL900 modules can link two terminal devices (“point-to-point” operation); multiple modules can be used together to create a network of various topologies, including “point-to-multipoint” and “repeater” operation. Multiple independent networks can operate concurrently, so it is possible for unrelated communications to take place in the same or a nearby area without sacrificing privacy or reliability.

## 1.1 Features

Key features of the pDDL900 include:

- transmission within a public, license-exempt band of the radio spectrum<sup>1</sup> – this means that it can be used without access fees (such as those incurred by cellular airtime).
- a serial I/O data port with handshaking and hardware flow control, allowing the pDDL900 to interface directly to any equipment with an asynchronous serial interface.
- ease of installation and use – the pDDL900 module uses a subset of standard AT style commands, very similar to those used by traditional telephone line modems.
- all units in a system are physically identical, and can be configured as a master, repeater or slave using the AT command set. No hardware modifications are required
- 128 sets of user-selectable pseudo-random hopping patterns, intelligently designed to offer the possibility of separately operating multiple networks while providing security, reliability and high tolerance to interference.
- encryption key with 65536 user-selectable values to maximize security and privacy of communications.
- 32-bit of CRC error detection and auto re-transmit to provide accuracy and reliability of data.

---

<sup>1</sup> 902-928 MHz and 2400-2483.5 MHz, which is license-free within North America; may need to be factory-configured differently for some countries.

- TDMA (time division multiple access) support, allowing multi-slave access in point-to-point mode.
- roaming ability, allowing repeaters and slaves to re-synchronize with a new master if the synchronization pulse from the original master is lost.

While the typical application for the pDDL900 is to provide a short- to mid-range wireless communications link between DTEs, it can be adapted to almost any situation where an asynchronous serial interface is used and data intercommunication is required.

## 2.1 Output Power Level

The Output Power Level determines at what power the pDDL900 transmits. The pDDL900's sensitive receiver can operate with very low power levels, so it is recommended that the lowest power necessary is used; using excessive power contributes to unnecessary "RF pollution".

Ideally, you should test the communications performance between units starting from a low power level and working upward until the RSSI is sufficiently high and a reliable link is established. The conditions will vary widely between applications, the output power settings can be calculated based on following information.

- Transmitter antenna gain
- Cable loss
- Equivalent Isotropically Radiated Power (EIRP) requirement by FCC Regulations

$$\text{Power Setting} = 36 - \text{Antenna Gain} - \text{Cable Loss}$$

The power setting must be no more than the above calculation value. Any higher is a violation of FCC rules. See IMPORTANT warning below.

**Table 1 Output Power**

Power Setting (dBm)	Approx. Output Power (mW)
20	100
21	125
22	160
23	200
24	250
25	320
26	400
27	500
28	630
29	800
30	1000

# 3. Installation

## 3.0 Overview

The pDDL900 complies with FCC part 15 at the modular level for operation in the license-free 902-928 MHz and 2400-2483.5 MHz ISM band. This chapter provides guidelines for installing and deploying equipment which incorporates the pDDL900 module.

## 3.1 Estimating the Gain Margin

Successful communication between pDDL900 modules is dependent on three main factors:

- System Gain
- Path Loss
- Interference

System gain is a calculation in dB describing the performance to be expected between a transmitter-receiver pair. The number can be calculated based on knowledge of the equipment being deployed. The following four factors make up a system gain calculation:

1. Transmitter power (user selectable)
2. Transmitter gain (transmitting antenna gain minus cabling loss between the transmitting antenna and the pDDL900 module)
3. Receiver gain (Receiving antenna gain minus cabling loss between the receiving antenna and the module)
4. Receiver sensitivity (Specified as -108dBm on the pDDL900 module)

In the following illustration, the transmitting antenna has a gain of 6 dB, and the receiving antenna has a gain of 3 dB. The cable loss between the module and the antenna is 2 dB on both the transmitting and receiving side.

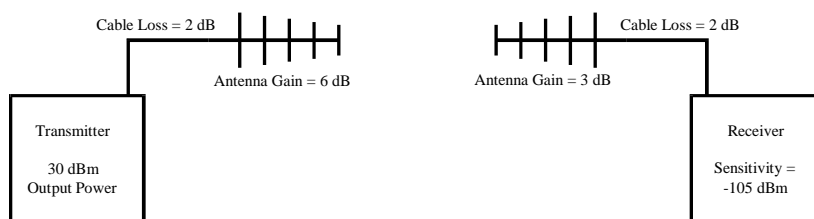

### Figure 1 Gain Calculation

The power level has been set to 30dBm (1W) on the transmitter, and the receiver sensitivity for the pDDL900 is -108dBm.

System gain would be calculated to be:

$$30 - 2 + 6 + 3 - 2 + 108 = 143 \text{ dB.}$$

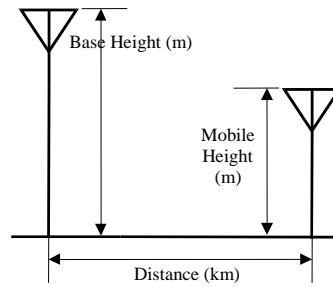

### Figure 2 System Deploying

When deploying your system, care must be taken to ensure the **path loss** (reduction of signal strength from transmitter to receiver in dB) between equipment does not exceed the system gain (140 dB in the above example). It is recommended to design for a **gain margin** of at least 20 dB to ensure reliable communication. Gain margin is the difference between system gain and path loss. Referring to the same example, suppose the path loss is 100 dB, the gain margin would be 40 dB, which is more than adequate for reliable communication.

Path loss is a very complicated calculation which mainly depends on the terrain profile, and the height of the antennas off the ground.

The following table provides path loss numbers for varying antenna heights and antenna separation: These numbers are real averages taken from rural environments. They do not apply to urban, non-line-of-sight environments.

**Table 2 Path Loss**

Distance (km)	Base Height (m)	Mobile Height (m)	Path Loss (dB)
5	15	2.5	116.5
5	30	2.5	110.9
8	15	2.5	124.1
8	15	5	117.7
8	15	10	105
16	15	2.5	135.3
16	15	5	128.9
16	15	10	116.2
16	30	10	109.6
16	30	5	122.4
16	30	2.5	128.8

Once the equipment is deployed, you can verify the signal strength by entering into Command Mode and reading Register S123. This register provides the average signal strength in dBm. The minimum strength for communication is roughly -108dBm. For consistent reliable communication, you should try to deploy the equipment such that signal strength exceeds -95dBm.

## 3.2 Antennas and Cabling

This section describes the recommended procedure for installing cabling and antennas for use with the pDDL900 module.

### 3.2.1 Internal Cabling

The most common method for installing the module is to run a cable from the module's UFL connector to a reverse TNC bulkhead connector on the chassis of the equipment as shown in Figure 3. This cable can be purchased from Microhard Systems.

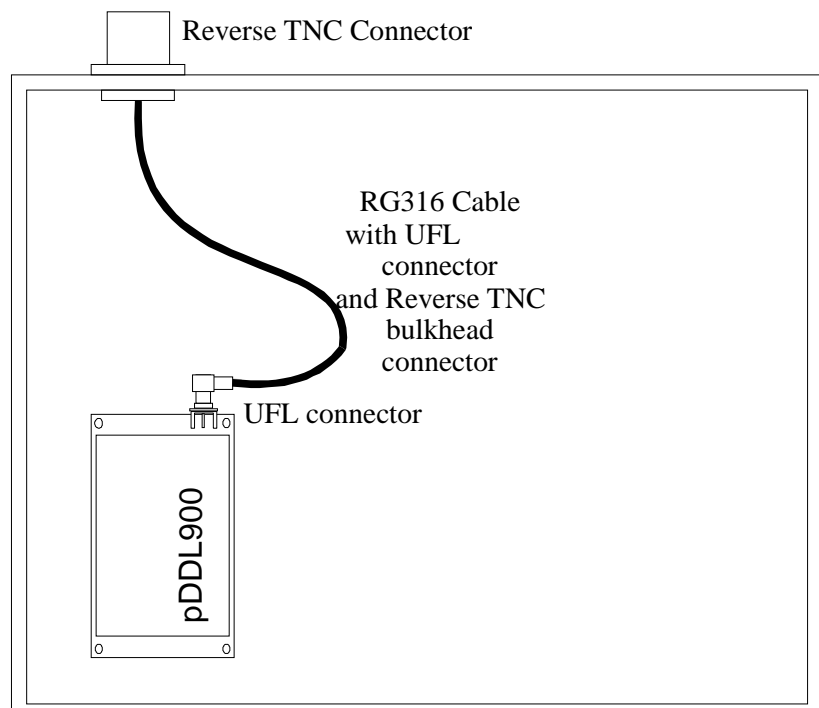

**Figure 3 Suggested Internal Cabling**

Cable losses are negligible for the short piece used within the chassis. Additional losses up to 0.5 dB may be present in the MCX and Reverse TNC connections.



**WARNING:**

To satisfy FCC/IC RF exposure requirements for mobile transmitting devices, a separation distance of 36 cm or more should be maintained between the antenna of this device and persons during device operation. To ensure compliance, operations at closer than this distance is not recommended. The antenna used for this transmitter must not be co-located in conjunction with any other antenna or transmitter.



**WARNING:**

Direct human contact with the antenna is potentially unhealthy when the pDDL900 is generating RF energy. Always ensure that the pDDL900 equipment is powered down during installation.



**WARNING:**

Never work on an antenna system when there is lightning in the area.

### 3.2.2 Installing External Cables, Antennas and Lightning Arrestors

Never work on an antenna system when there is lightning in the area.

Direct human contact with the antenna is potentially unhealthy when the pDDL900 is generating RF energy. Always ensure that the pDDL900 equipment is powered down during installation. At all times a distance of 36 cm must be maintained between the antenna and any person when the device is in operation.

#### Surge Arrestors

The most effective protection against lightning is to install two lightning (surge) arrestors, one at the antenna, the other one at the interface with the equipment. The surge arrestor grounding system should be fully interconnected with the transmission tower and power grounding systems to form a single, fully integrated ground circuit. Typically, both ports on surge arrestors are N-female.

#### External Filter

Although the pDDL900 is capable of filtering out RF noise in most environments, there are circumstances that require external filtering. Paging towers and cellular base stations in close proximity to the pDDL900 antenna can desensitize the receiver. Microhard Systems' external cavity filter eliminates this problem. The filter has two N-female ports and should be connected in line at the interface to the RF equipment.

#### Weatherproofing

Type N and RTNC connectors are not weatherproof. All connectors should be taped with rubber splicing tape (weatherproofing tape), and then coated with a sealant.

#### Cabling

The following coax cables are recommended:

**Table 3 Cable Loss**

Cable	Loss (dB/100ft)
LMR 195	10.7
LMR 400	3.9
LMR 600	2.5

Factors to take into consideration when choosing a cable are:

- price;
- bend radius limitations (the lower performance cables generally can bend more sharply)
- performance requirements; and,
- distance between the equipment and the antenna.



**WARNING:**  
**MAXIMUM EIRP**  
 FCC and IC Regulations allow up to 36dBm effective isotropically radiated power (EIRP). Therefore, the sum of the transmitted power (in dBm), the cabling loss and the antenna gain cannot exceed 36 dBm with respect to the isotropic radiator.



**WARNING:**  
 The pDDL900 can only be used with any antennas listed in Appendix A.



**WARNING:**  
 Be careful with dBi vs dBd gains on antenna specifications. Antenna manufactures may not clearly indicate the gain on the antenna if it is dBd or dBi. Note 1dBd = 2.15dBi.

When installing the cable, always begin fastening at the top near the antenna connector/surge arrester. The cable must be supported at the top with a hose clamp or wrap lock, and at 5 ft intervals down the length of the tower. Over-tightening the fasteners will dent the cable and reduce performance. If properly grounded surge arrestors are not installed at both the top and the bottom of the cable, then the cable should be grounded to the tower at these locations using a cable grounding kit. If the tower is non-conductive, then a separate conductor, physically separate from the cable, should be run down the tower.

**Antenna**

Before choosing an antenna, you should have some knowledge of the path loss and the topology of the equipment. If the equipment is in a fixed location and is to communicate with only one other unit also in a fixed location, then a Yagi antenna is suitable. Choose a Yagi with enough gain to ensure adequate gain margin. When deploying the Yagi, point the antenna towards the intended target, ensuring the antenna elements are perpendicular to the ground for vertical polarization.

In applications where there are multiple units that you must communicate with or units, which are in motion, you may select an Omni-directional antenna with appropriate gain.

**See appendix A for a list of approved antennas that can be used with the pDDL900 radio modem. If you require another type of antenna please contact Microhard Systems Inc. The pDDL900 CANNOT be used with any antenna that does not appear in Appendix A.**

Microhard Systems Inc. can provide you with approved antennas to ensure FCC and ISED compliance.

**FCC Regulations allow up to 36dBm effective isotropically radiated power (EIRP). Therefore, the sum of the transmitted power (in dBm), the cabling loss and the antenna gain cannot exceed 36dBm with respect to the isotropic radiator.**

EIRP is calculated as follows:

$EIRP = Tx\ Power(dBm) - Cable/Connector\ Loss(dB) + Ant\ Gain(dBi)$
----------------------------------------------------------------------

**Antenna Gains must be in dBi when calculating the 36dBm EIRP limit.**

$1dBd = 2.15dBi$
------------------

Use the guidelines in the previous section for calculating cable and connector losses. If cabling and connector losses are 2 dB, then the maximum allowable gain of the antenna will be 8 dB.

**Examples of Antenna and Power settings to maintain 36dBm EIRP**

Antenna	Power Level	Minimum Cable / Loss	EIRP
8.15 dBi Omni	30dBm	25 feet LMR195 / 2.675dB	35.475dBm
12.5 dBi Patch	23dBm	10 feet LMR195 / 1.07dB	34.43dBm
14.15 dBi Yagi	21dBm	10 feet LMR400 / 0.39dB	34.76dBm

---

**Examples:**

**FCC and ISED Regulations allow up to 36dBm effective isotropically radiated power (EIRP). Therefore, the sum of the transmitted power (in dBm), the cabling loss and the antenna gain cannot exceed 36dBm with respect to the isotropic radiator.**

---

**Example 1)**

**What is the maximum power the pDDL900 can be set to comply with FCC and IC given the following equipment given a Rubber Ducky Ant Gain 2dBi and no cable or connectors in the system?**

Max EIRP 36dBm

Max TX power = EIRP – Ant Gain(dBi) + Cable/Connector loss (dB)

Ant Gain dBi = 2dBi

Max TX power = 36dBm – 2dBi + 0dB = 34dBm

We can set the modem to the maximum power setting of 30dBm.

---

**Example 2)**

**What is the maximum power the pDDL900 can be set to comply with FCC and IC given the following equipment given a Yagi Ant Gain 12dBd and cable and connector loss of 4.5 dB?**

Max EIRP 36dBm

Max TX power = EIRP – Ant Gain(dBi) + Cable/Connector loss (dB)

Ant Gain dBi = Ant Gain dBd + 2.15 dB

Yagi Gain (dBi) = 12 + 2.15 = 14.15dBi

Max TX power = 36dBm – 14.15dB + 4.5dB = 26.35dBm

We must round down

Hence Max TX power = 26dBm

---

**Example 3)**

**What is the maximum power the pDDL900 can be set to comply with FCC and IC given the following equipment given a Omni Ant Gain 6dBd and cable and connector loss of 2.5 dB?**

Max EIRP 36dBm

Max TX power = EIRP – Ant Gain(dBi) + Cable/Connector loss (dB)

Ant Gain dBi = Ant Gain dBd + 2.15 dB

Omni Gain (dBi) = 6 + 2.15 = 8.15dBi

Max TX power = 36dBm – 8.15dB + 2.5dB = 30.35dBm

Hence Max TX power = 30dBm

---



# A. Approved Antennas

This radio transmitter (IC: 3143A-17PDDL900) has been approved by ISED to operate with the antenna types listed below with the maximum permissible gain indicated. Antenna types not included in this list, having a gain greater than the maximum gain indicated for that type, are strictly prohibited for use with this device.

## 2400MHz antennas:

Group	Part Number	Description
<b>Rubber Ducky</b>		
	MHS031100	2dBi, 2.4GHz Rubber Ducky Antenna RPTNC Swivel
	MHS031110	2dBi, 2.4GHz Rubber Ducky Antenna Reverse SMA Swivel
	MHS031120	2dBi, 2.4GHz Rubber Ducky Antenna Reverse SMA Straight
	NW001	2.5dBi, Shenzhen Norminson Technology CO.LTD. - 2.4GHz Rubber Ducky Antenna Reverse SMA Straight
	WCP2400-MMCX4	2.5dBi, Laird Technologies - 2.4GHz Rubber Ducky MMCX
<b>Yagi Antennas</b>		
	MHS034100	9 dBi, 2.4GHz Yagi Directional Antenna RPTNC Pigtail
	MHS034000	12 dBi, 2.4GHz Yagi Directional Antenna RPTNC Pigtail
	MHS034120	14 dBi, 2.4GHz Yagi Directional Antenna RPTNC Pigtail
	MHS034150	14.5 dBi, 2.4GHz Yagi Directional Antenna RPTNC Pigtail
<b>Patch Antennas</b>		
	MHS034200	8 dBi, 2.4GHz Mini Flat Patch Directional Antenna RPTNC Pigtail
	MHS034210	14 dBi, 2.4GHz Flat Patch Directional Antenna RPTNC Pigtail
<b>Omni Directional</b>		
	MHS031260	5 dBi, Omni Directional Antenna RPTNC Pigtail
	MHS034000	6 dBi, 2.4GHz Omni Directional Antenna RPTNC Pigtail
	MHS031340	8 dBi, Omni Directional Antenna RPTNC Pigtail
	MHS034020	10.5 dBi, 2.4GHz Omni Directional Antenna RPTNC Pigtail
	MHS034030	12 dBi, 2.4GHz Omni Directional Antenna RPTNC Pigtail
	MHS034040	15 dBi, 2.4GHz Omni Directional Antenna RPTNC Pigtail

## 900MHz antennas:

Group	Part Number	Description
<b>Rubber Ducky</b>		
	MHS031000	3dBi, 900MHz Rubber Ducky Antenna RPTNC Swivel
	MHS031070	3dBi, 900MHz Rubber Ducky Antenna Reverse SMA Swivel
	MHS031080	3dBi, 900MHz Rubber Ducky Antenna Reverse SMA Straight
<b>Transit Antennas</b>		
	MHS031210	3dBi, 900 MHz Transit Antenna with Ground Plane
	MHS031220	3dBi, 900MHz Transit Antenna No Ground Plane
	MHS031230	3dBi, 900MHz Transit Antenna Permanent Mount GP
	MHS031240	3dBi, 900MHz Transit Antenna Permanent Mount NGP
<i>Mounts for Transit Antennas have a RPTNC Pigtail</i>		
<b>Yagi Antennas</b>		
	MHS031311	6dBd, 900MHz Yagi Directional Antenna Antenex, RPTNC Pigtail
	MHS031431	6.5dBd, 900MHz Yagi Directional Antenna Bluewave, RPTNC Pigtail
	MHS031501	9dBd, 900MHz Yagi Directional Antenna Antenex, RPTNC Pigtail
	MHS031441	10dBd, 900 MHz Yagi Directional Antenna Bluewave, RPTNC Pigtail
	MHS031451	11dBd, 900 MHz Yagi Directional Antenna Bluewave, RPTNC Pigtail
<b>Patch Antennas</b>		
	MHS031440	8dBi 900 MHz Patch Antenna, RPTNC Pigtail
<b>Omni Directional</b>		
	MHS031251	3dBd, 900MHz Omni Directional Antenna Antenex, RPTNC Pigtail
	MHS031461	3dBd, 900 MHz Omni Directional Antenna Bluewave, RPTNC Pigtail
	MHS031321	6dBd, 900MHz Omni Directional Antenna Antenex, RPTNC Pigtail
	MHS031471	6dBd, 900 MHz Omni Directional Antenna Bluewave, RPTNC Pigtail



### **WARNING:**

Changes or modifications not expressly approved by Microhard Systems Inc. could void the user's authority to operate the equipment. This device has been tested with UFL connectors with the antennas listed in Appendix A. When integrated in OEM products, fixed antennas require installation preventing end-users from replacing them with non-approved antennas. Antennas not listed in the tables must be tested to comply with FCC Section 15.203 (unique antenna connectors) and Section 15.247 (emissions). Please Contact Microhard Systems Inc. if you need more information.

**ISED:** This device has been designed to operate with the antennas listed above, and having a maximum gain of 15 dBi. Antennas not included in this list or having a gain greater than 15 dBi are strictly prohibited for use with this device. The required antenna impedance is 50 ohms. To reduce potential radio interference to other users, the antenna type and its gain should be so chosen that the equivalent isotropically radiated power (EIRP) is not more than that required for successful communication. This Class B digital apparatus complies with Canadian ICES-003.

**ISED:** Cet appareil a été conçu pour fonctionner avec les antennes énumérées ci-dessus, et ayant un gain maximal de 15 dBi. Antennes pas inclus dans cette liste ou présentant un gain supérieur à 15 dBi sont strictement interdits pour une utilisation avec cet appareil. L'impédance d'antenne requise est de 50 ohms. Pour réduire les interférences radio potentielles pour les autres utilisateurs, le type d'antenne et son gain doivent être choisis afin que la puissance isotrope équivalente (PIRE) ne soit pas supérieure à celle requise pour une communication réussie rayonnée. Cet appareil numérique de classe B est conforme à la norme ICES -003 du Canada.