

# MTU4



MTU4 Technical Manual  
Issue 1.11  
10 Oct 2012

## Conditions

This publication and all associated programs and other documents are Copyright (C) 2012 by *Microlise*. No part of this publication, or its associated programs and other documentation, may be reproduced, transmitted, transcribed, stored in a retrieval system, or transcribed into any human or computer language, in any form or by any means, electronic, mechanical, magnetic, optical, chemical, manual or otherwise, without the express written permission of *Microlise*.

The issue and/or possession of this document does not entitle the recipient to have or to use, or have access to, the **Microlise Tracking Unit 4 (MTU4)** product. Such use or access is subject to separate contracts or product licences. Whilst every effort is made to ensure that the information contained in this document is correct, *Microlise* makes no representations or warranties with respect to the contents hereof and does not accept liability for any errors or omissions. If for any reason the foregoing disclaimer is ineffective, the liability of *Microlise* shall not exceed that which it may have under the contract pursuant to which this document has been supplied.

Any particular release of the **MTU4** product may not contain all the facilities described in this document. New releases of the product may contain extra facilities which are not described in this document. *Microlise* will, in this latter case and if requested, supply additional information about any extra facilities supplied with a user's particular release of the product.

## Battery pack safety

The MTU4 contains a Li-ion battery pack. This is not user replaceable. If replacement is needed please contact Microlise Service.

**CAUTION:** RISK OF EXPLOSION IF BATTERY IS REPLACED BY AN INCORRECT TYPE. DISPOSE OF BATTERY ACCORDING TO THE INSTRUCTIONS.

**Please note:** Batteries must not be disposed of with normal household or business waste. Please dispose of in accordance with local regulations in force for battery disposal.

## FCC Rules

This device complies with part 15 of the FCC Rules. Operation is subject to the following two conditions: (1) This device may not cause harmful interference, and (2) this device must accept any interference received, including interference that may cause undesired operation.

Changes or modifications to the MTU4 unit not expressly approved by Microlise could void the user's authority to operate the equipment.

Note: This equipment has been tested and found to comply with the limits for a Class B digital device, pursuant to part 15 of the FCC Rules. These limits are designed to provide reasonable protection against harmful interference in a residential installation. This equipment generates, uses and can radiate radio frequency energy and, if not installed and used in accordance with the instructions, may cause harmful interference to radio communications. However, there is no guarantee that interference will not occur in a particular installation. If this equipment does cause harmful interference to radio or television reception, which can be determined by turning the equipment off and on, the user is encouraged to try to correct the interference by one or more of the following measures:

- Reorient or relocate the receiving antenna.
- Increase the separation between the equipment and receiver.
- Connect the equipment into an outlet on a circuit different from that to which the receiver is connected.
- Consult the dealer or an experienced radio/TV technician for help.

## R&TTE directive



This device complies with the European Radio and Telecommunication Terminal Equipment (R&TTE) directive, including product safety and electrical interference directives.

## Revision history

Issue 1.0	Initial draft for internal review.	23 January 2012
Issue 1.1	First release.	25 January 2012
Issue 1.2	Battery capacity incorrectly stated as 5.7 Ahr. Corrected to 5.2 Ahr.	30 January 2012
Issue 1.3	<ol style="list-style-type: none"> <li>1. GSM / Bluetooth audio call set up details added.</li> <li>2. Bluegiga BlueTest3 test application details added.</li> <li>3. External antenna guidance notes added.</li> </ol>	20 February 2012
Issue 1.4	<ol style="list-style-type: none"> <li>1. Battery warning and disposal information added.</li> <li>2. In-line wiring harness fuse type specified.</li> </ol>	27 March 2012
Issue 1.5	Upper supply voltage limit revised to 32V d.c.	14 June 2012
Issue 1.6	<ol style="list-style-type: none"> <li>1. Signal path annotation added to block diagram</li> <li>2. FCC regulatory information added</li> </ol>	2 Aug 2012
Issue 1.7	<ol style="list-style-type: none"> <li>1. FCC Class B “information to the user” added</li> <li>2. Description of operation updated to include details of all sections of the circuit and both antenna options.</li> </ol>	7 Aug 2012
Issue 1.8	Details of GSM and Bluetooth antennas added	13 Aug 2012
Issue 1.9	Details of diagnostic screen added	16 Aug 2012
Issue 1.10	Copy of European Declaration of Conformity added, R&TTE / CE compliance detail and details of functions not supported in USA	30 Sept 2012
Issue 1.11	External antenna specifications for FCC compliance added	10 Oct 2012

## Contents

1	Overview .....	5
2	Installation .....	5
3	Wiring .....	6
4	Description of operation .....	6
5	Antenna details .....	7
5.1	Bluetooth .....	7
5.2	GSM .....	7
6	Tuning and serviceable parts .....	7
7	Block diagram .....	8
8	Configuration and diagnostics menu .....	8
8.1	Establishing a GPRS connection and monitoring the GPS stream .....	10
8.2	Establishing a voice call, using a Bluetooth headset .....	10
8.3	Using the Bluegiga BlueTest3 application .....	11
9	Technical specification .....	13
10	EU Declaration of Conformity .....	14

## 1 Overview

The **Microlise Tracking Unit 4 (MTU4)** is battery backed, vehicle tracking and telematics unit utilizing GPS, GSM / GPRS and Bluetooth technology.

The unit is available in two hardware variants:

- a) MTU4-A with integral GSM and GPS antennas
- b) MTU4-B with SMA connectors for connecting external GSM and GPS antennas

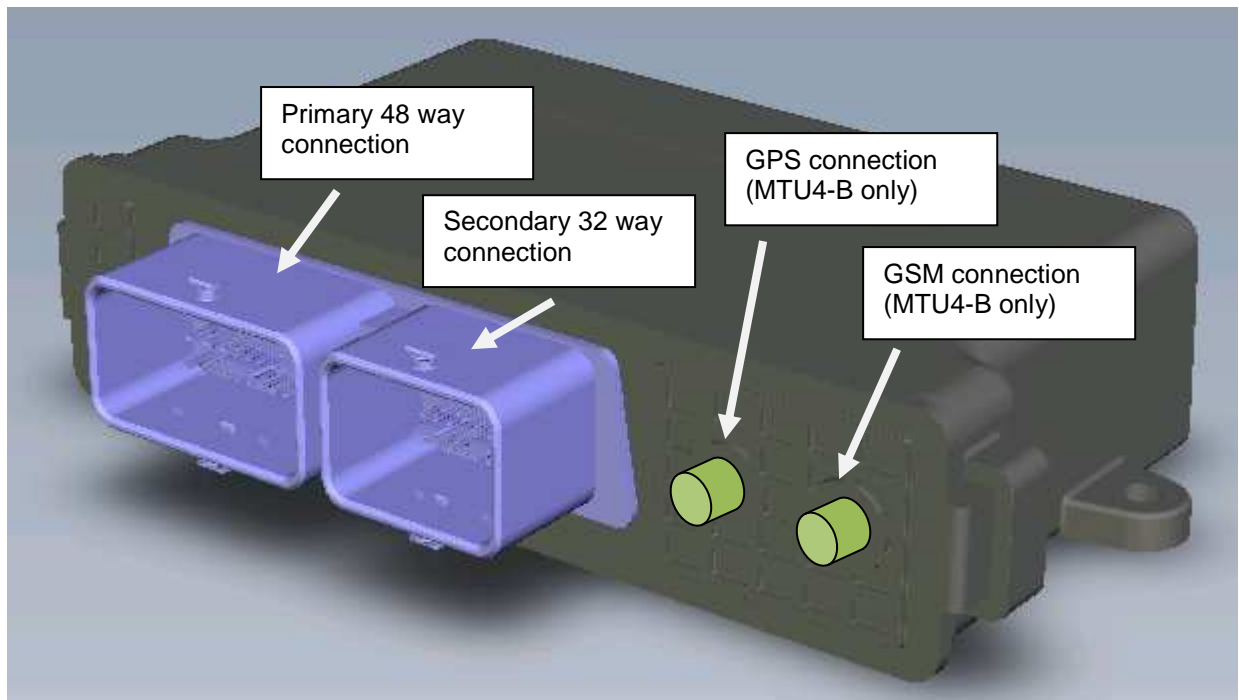

Units are supplied to customers pre-configured by Microlise with appropriate configurations along with wiring harnesses to suit the intended application.

## 2 Installation

The MTU4 is designed for installation both within the vehicle cab and also for installation on a trailer.

Depending on the application the device may be permanently powered (e.g. an in cab installation) or powered only periodically (e.g. in a trailer tracking application only when the trailer is hooked up to a tractor unit.) However, in either application the unit is designed to make efficient use of the power available through the use of sleep modes when there is no activity.

When selecting a suitable mounting location, please be aware of:

- Excessive temperatures (operating temperature: -25°C to 55°C)
- Corrosive fluids
- Areas where the unit may obstruct the drivers view or impede operation of the vehicle
- Locations which may shield the unit and affect GPS and GPRS reception.

If an external antenna is being used with the unit, then it should be located at least 30 cm from the MTU4 and any other ECU in the vehicle. Any excess antenna cable must not be tightly coiled up. The installation must be carried out in accordance with FCS1362:2010 or later, by a competent auto-electrician.

### 3 Wiring

For basic in cab installations only the following wires need be connected:

MTU4 primary connector pin no	Wire colour	Signal	In-line fuse* required
P2M	Red	12V or 24V supply	3A
P3K	Yellow	Ignition	1A
P4K	Orange	Engine run	1A
P1M	Black	Ground	None

For bench testing, connect the red, yellow and orange wires to a +12V or 24V supply and the black wire to 0V / Ground.

\* Fuses and all replacements need to be automotive blade type ATO.

### 4 Description of operation

Providing external power is applied, or the internal battery is sufficiently charged, and the unit is within GPS and GPRS coverage the unit will periodically (based on time and/or distance, and configuration) transmit location and telematics information to the relevant Microlise system.

If out of GPRS coverage then messages are stored into non-volatile Flash memory for transmission later when a GPRS connection can be established.

Whilst operating on external power the unit will charge the internal battery as required.

Two CAN interfaces are incorporated which are typically used to either listen for, or request information on automotive CAN busses.

The unit incorporates three RS232 interfaces which can be used for connection of a variety of peripherals, e.g. Mobile Data Terminals, refrigeration temperature monitoring equipment, printers, sensors or other devices.

A Dallas 1 wire interface is provided. This is typically used for driver identification via Dallas iButtons, but could also be used with any other device in the "1 wire" range.

Connection can be made to a vehicle Digital Tachograph via the built in digital tachograph interface. This can be as an alternative way to identify the driver and also capture information needed to comply with regulations regarding drivers' hours.

The unit incorporates seven digital inputs. Two are available for monitoring ignition status, another for engine run, the remainder are general purpose inputs which can be used for monitoring doors switches, panic buttons or other digital signals.

A real time clock is incorporated for time-stamping all events recorded by the unit.

The unit monitors its own internal temperature. Battery charging is only permitted when the temperature is within the specified limits of the battery pack.

The Bluetooth interface can be used for diagnostics, for connection to peripheral devices, e.g. a data terminal, and also for audio connection to a Bluetooth car kit for hands free voice calls.

A USB OTG (on the go) port is provided. This can also be used for diagnostics, but can also be used for connection to a range of USB host or slave devices.

Using the built in Codec and a audio output via Bluetooth the unit can play tones or make audible announcements to the driver of a vehicle, e.g. to provide real time feedback on driving style.

Depending on the device purchased, the unit is fitted with internal GSM and GPS antennas, or is provided with SMA connections to which separate, or a combined GSM/GPS, antennas may be connected.

A microSD card may be fitted internal for applications requiring additional Flash storage capacity.

Two relay outputs with change over contacts are provided for remote control of other devices.

The built in accelerometer can be used to monitor harsh braking, acceleration, cornering, and any lean of the vehicle.

The built in GSM modem supports four GSM frequency bands (850, 900, 1800 & 1900 MHz). The 900 and 1800 MHz bands are used in Europe, but are not operational in the USA. The 850 and 1900 MHz bands are the only bands used for GSM in the USA and Canada.

## 5 Antenna details

### 5.1 Bluetooth

Both variants of the product (MTU4-A and MTU4-B) incorporate the Bluegiga WT32-A Bluetooth module. This module has a built in chip antenna with a peak gain of 1.5 dBi.

### 5.2 GSM

The MTU4-A has a built in custom designed GSM antenna. This has a gain of 0 dBi.

The MTU4-B has a SMA connection to which an external GSM antenna can be connected. A typical antenna is the Hirshmann GPS1890LP, the GSM gain of which is 0 dBi.

**Please note:** To comply with FCC regulations the external antenna gain, including cable loss, must not exceed 3.0dBi at 1900 MHz / 1.4dBi at 850 MHz

## 6 Tuning and serviceable parts

The MTU4 contains no user tunable parts. The MTU4 contains no user serviceable parts.

## 7 Block diagram

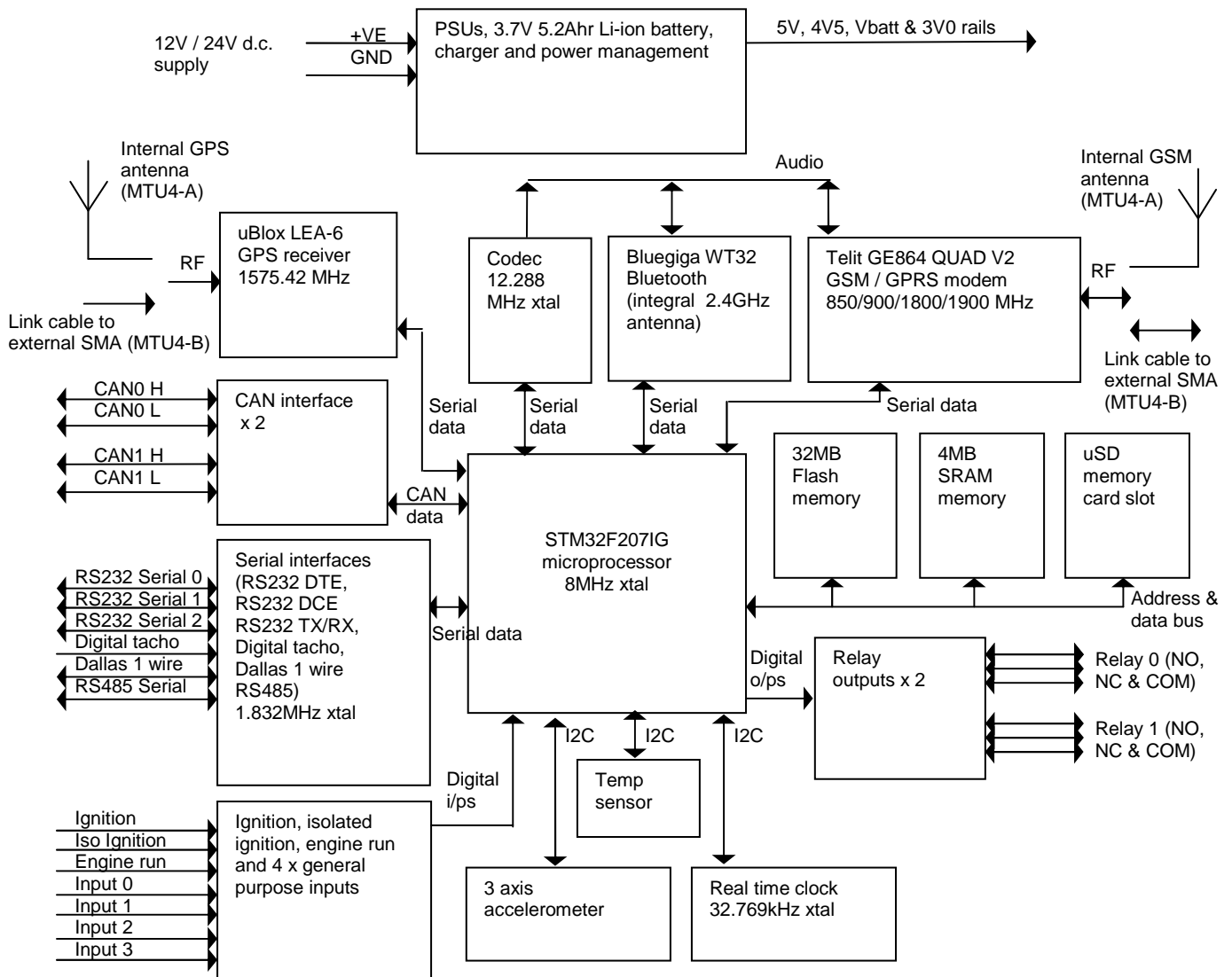

## 8 Configuration and diagnostics menu

To access the configuration and diagnostics menu a PC or laptop with a RS232 port (or a USB to RS232 adaptor) should be connected to the MTU4 as follows:

MTU4 primary connector pin no	MTU4 signal	PC / laptop serial port pin no	PC serial port signal
P3C	DTE-RX	3	Transmit
P1C	DTE-TX	2	Receive
P1B	Ground	5	Ground

On the PC or laptop execute a terminal program, e.g. Hyperterminal, and set the RS232 configuration as follows: *115200 baud, 8 bit, no parity, 1 stop bit*

By default the unit will output debug messages to the terminal program.



On hitting the “Esc” key the following menu will appear:

```

Main Menu

1 - Debugs
2 - Logs
3 - View Config
4 - Test
5 - Configure
6 - Download
7 - CAN Event Data
8 - CAN Log Data
9 - Advanced Menu

Enter option >
```

Press ‘4’ to select the “Test” screen as follows:

```

Status Screen

MTU4 Time      :Thursday, 16/08/12,20:43:37
IMEI          :351934045707440      Telit 865: 10.00.023
Ver           :1.5.6  crc 0x2c40 size:384464
IMSI         :234159119456948
ICCID        :89441000302007987555
Sig Q        :13 = 41 Percent
GPRS         :Connected
IP           :10.180.30.211
SRVR         :94.125.17.212      Connected      5432
Power Retain :7200  Sleep: 900=0    Re-try: 6
VIN          :00000000000000000000  source 0x00

GPSVer        :HW:00040007      SW:7.03 (45969)
Latitude     : 52.91347120      Power          :Off (0.32v)
Longitude    : -1.23514640      Ignition       :Off
GPSFix       :TRUE              Ch0 (DPU)     :Low
Num Sats     :5                  Ch1 (DPU)     :Low
Speed        : 0.000000          Ch2 (DPU)     :Low
Course       : 0.000000          Ch3 (DPU)     :Low
Distance     :0000014934        Shut Down     :16s
GPS Antenna  :0                  Batt Capacity  :unknown (3.65v)
GPS err (fHacc) : 39.00          Charge State   :Standby
GPS FixCount : 0

MainMin :2498 MainMax :3873 MainCurrent :2498 MainMaxT :0022
TIM5 Counters (10us/cnt)
Loop Time   : Max :00002181 Current :00000039 (00000494)
Func 03    : Max :00002142 Current :00000014 (00002142)
```

For advanced options, press '9'. The following menu will then appear:

```
Advanced Menu

a - Direct GSM
b - Direct GPS
c - Direct Bluetooth
d - Device Tests
e - Device Info
f - Current Settings
g - Upload
h - Erase Config
i - Erase Reports
j - Erase Datastore
k - Erase Debugs
l - Immediate Reset
m - Erase ASSET / set VIN
n - Power Supply Control
y - Direct BlueTest3
z - Prod Test

Enter option >
```

To return to the "Main Menu" press "Esc"..

## 8.1 Establishing a GPRS connection and monitoring the GPS stream

Select menu options '9 a' for a "Direct GSM" connection.

Once selected, AT commands may be sent directly to the integral GSM modem.

e.g. type "AT+CGATT=1" (without double quotes) to put the modem into auto attach mode for GPRS testing.

Press "Ctrl" "g" to switch to the GPS stream and "Ctrl" "a" to switch back to the GSM modem, if needed.

Once testing is complete press "Esc" to return to the "Advanced Menu" and "Esc" again to return to the "Main Menu".

Note: Pressing "Esc" when in any "Direct ... " mode will cause the unit to resume normal tracking operations and close any GPRS connection or GSM call.

## 8.2 Establishing a voice call, using a Bluetooth headset

Select menu option '9 c' for a "Direct Bluetooth" connection, then follow the steps below:

1. Type "AT" (without quotes) and check for response "OK"

*If pairing with the Bluetooth headset has been carried out previously, then skip steps 2 to 12 and jump to step 13.*

2. Type the following commands to clear any previous pairing:

```
SET BT PAIR *
```

```
SET RESET
```

3. Check for Bluegiga copyright message and "READY"

4. Type the following commands:  
SET BT CLASS 200408  
SET PROFILE HFP-AG ON  
SET BT AUTH \* 0000
5. Set the headset into discoverable mode by holding the silver button pressed for 6 seconds. The led should then flash red / blue.
6. Type the following command:  
PAIR 00:23:7F:7D:AB:8D *(replace "00:23:7F:7D:AB:8D" with the MAC address of headset being used)*
7. Check for the response:  
PAIR 00:23:7F:7D:AB:8D OK
8. Type the following command:  
CALL 00:23:7F:7D:AB:8D 111E HFP-AG
9. Check for response "CONNECT 0 .... "
10. Pressing volume on headset should cause responses to appear in terminal window.
11. Power down the MTU4 and the headset, then re-apply power / switch on both.
12. Select menu option "9 c" for "Direct Bluetooth"
13. Type "RING", then press the silver button the headset twice
14. Check for the response:  
RING 1 00:23:7f:7d:ab:8d SCO
15. Press "Ctrl" "a" to switch to "Direct GSM" mode
16. Type the following commands:  
AT#CAP=2  
ATD07977008706; *(Change the phone number to suit. Note the trailing ";")*
17. A voice call should now be established.
18. To end the GSM call type "ATH"
19. To end the Bluetooth audio connection press "Ctrl" "b", then type "HANGUP"

Once testing is complete press "Esc" to return to the "Advanced Menu" and "Esc" again to return to the "Main Menu".

Note: Pressing "Esc" when in any "Direct ... " mode will cause the unit to resume normal tracking operations and close any GPRS connection or GSM call.

### 8.3 Using the Bluegiga BlueTest3 application

Select menu option '9 y' for a "Direct BlueTest3" connection.

The following should appear:

*Direct BlueTest3*

Exit the terminal program and start the "BlueTest3" utility

In the "Transport" box select "BCSP"

In the "Serial Port" box choose the COM port previously used by the terminal application..

In the "Baud Rate" box choose "115200"

Click "OK"

Communication should now be established with the BlueGiga module.

## 9 Technical specification

Item	Specification
Power Supply	6 – 32 V dc or internal 5.2Ahr 3.7V Li-ion battery
Current Consumption	
Sleep:	< 2mA
Operating:	< 2A
Supported interfaces:	RS232 x 2 (1 x DTE, 1 x DCE) RS232 TX / RX only Digital tachograph serial Dallas 1 wire Engine run Ignition Isolated ignition Analog / digital inputs x 4 Relay outputs (NO / NC) x 2 CAN bus interface x 2 RS485 interface USB host / slave OTG port Bluetooth (HF-AG and SPP) Accelerometer 3V SIM card interface
GSM/GPRS	
Modem:	Quad band (850, 900, 1800, 1900 MHz bands supported)
Power:	850/900 Class 4 (2W) 1800/1900 Class 1 (1W)
GPRS:	Multi-slot Class 10, Class B
Voice support:	MT & MO
SMS support:	MT & MO
GPS	
Receiver:	High-sensitivity, L1 frequency, C/A code
Channels:	50 channels, SBAS (WAAS, EGNOS, MSAS support)
Accuracy:	2.5m CEP
Antenna supply:	3V output for active antennas
Mechanical	
Dimensions:	180mm x 40mm x 115mm
Weight:	approx. 500g
Environmental	
Operating temperature:	-25°C to +55°C
Storage temperature:	-40°C to +85°C
Ingress protection:	IP69k

## 10 EU Declaration of Conformity



### DECLARATION OF CONFORMITY

We,

*Microlise Ltd*

Of: Farrington Way, Eastwood, Nottingham, NG16 3AG

Declare under our sole responsibility that the products:

MTU4-A – Vehicle tracking and telematics unit (internal antenna variant)  
MTU4-B – Vehicle tracking and telematics unit (external antenna variant)

to which this declaration relates, are in conformity with the following standards and / or other normative documents:

Health (Art 3.1(a)):	EN 62311:2008
Safety (Art 3.1(a)):	EN 60950-1:2006 + A11:2009 + A1:2010 + A12:2011
EMC (Art 3.1(b)):	ETSI EN 301 489-1: V1.8.1:2008 ETSI EN 301 489-7: V1.3.1:2005 ETSI EN 301 489-17: V2.1.1:2009
Spectrum (Art 3.2):	ETSI EN 300 328: V1.7.1:2006 ETSI EN 300 440-2: V1.4.1:2010-08 ETSI EN 301 511: V9.0.2:2003
Other (incl. Art 3.3):	N/A

We hereby declare that all essential radio test suites have been carried out and the above named products are in conformity to all the essential requirements of the directive 1999/5/EC.

The conformity assessment procedure referred to in Article 10 and detailed in Annex III or IV of Directive 1999/5/EC has been followed with the involvement of the following Notified Body:

**TÜV SÜD BABT, Forsyth House, Churchfield Road, Walton-on-Thames, Surrey, KT12 2TD, UK**

Identification mark **0168** (*Notified Body Number*)

The technical documentation relevant to the above equipment will be held at:  
Microlise Limited, Farrington Way, Eastwood, Nottingham, NG16 3AG, United Kingdom

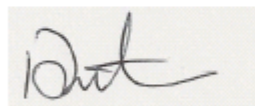

Ian Dickinson, Director of Technical Services.  
20 September 2012

Microlise Engineering Ltd. Farrington Way Eastwood Nottingham NG16 3AG  
t +44 (0)1773 537000 f +44 (0)1773 537373 enquiries@microlise.com www.microlise.com

Registered Office: Farrington Way Eastwood Nottingham NG16 3AG VAT No. 894 5425 02  
Microlise Group Ltd. Reg No. 1670983 Microlise Engineering Ltd. Reg No. 2211125 Microlise Ltd. Reg No. 3037936