

MICROSCAN.

LVS[®] 95XX Series Barcode Quality Station Operations Manual

English



Copyright ©2016
Microscan Systems, Inc.
Tel: +1.425.226.5700 / 800.762.1149
Fax: +1.425.226.8250

All rights reserved. The information contained herein is proprietary and is provided solely for the purpose of allowing customers to operate and/or service Microscan manufactured equipment and is not to be released, reproduced, or used for any other purpose without written permission of Microscan.

Throughout this manual, trademarked names might be used. We state herein that we are using the names to the benefit of the trademark owner, with no intention of infringement.

GS1 Solution Partner



Disclaimer

The information and specifications described in this manual are subject to change without notice.

Latest Manual Version

For the latest version of this manual, see the Download Center on our web site at:
www.microscan.com.

Technical Support

For technical support, e-mail: helpdesk@microscan.com.

Warranty

For current warranty information, see: www.microscan.com/warranty.

Microscan Systems, Inc.

United States Corporate Headquarters

+1.425.226.5700 / 800.762.1149

United States Northeast Technology Center

+1.603.598.8400 / 800.468.9503

European Headquarters

+31.172.423360

Asia Pacific Headquarters

+65.6846.1214

Table of Contents

Product Discontinuation Notice	7
LVS-9500 Product Discontinuation	7
LVS-9505 Product Discontinuation	7
Overview	8
Installation Assistance	10
System Manuals	10
Windows XP Operating Instructions.....	11
Windows 7 Operating Instructions	11
Safety Instructions	12
LVS-95XX Series Software Specifications	13
LVS-9510 and Auxiliary Readhead Hardware Specifications	15
LVS-9570 Hardware Specifications	16
LVS-9580 Hardware Specifications	17
LVS-9500 Hardware Specifications	18
LVS-9505 Hardware Specifications	18
Basic Operations	20
To Print the Results.....	22
To View the Report.....	22
Welcome Tab	23
Choice of Language	23
Toggling the LVS-95XX Software between Two Languages	24
Current Software Version List	24
Password Login.....	25
Setup Tab	26
Camera	26
Grading Mode	28
Auto-Sector Feature	29
Application Standards	30
Selecting an Application Standard	31
Application Standard Shortcut Keys.....	32
Default Shortcut Keys.....	32
Override Aperture.....	33
Creating Custom Reports.....	33
Current Information	33
Change the Time Zone:.....	33

System Settings	34
Minimum Passing Score.....	34
Days before password expires	34
Minutes before auto logoff.....	34
Days before calibration needed.....	34
Allow Non-ISO blemish to affect grade	34
Metric.....	35
Quiet zone processing.....	35
Reference.....	37
Additional Reference	37
Company Name on Reports.....	37
Setup Operators	37
Product Lookup	38
Distributor Information	39
Optional Features.....	39
List of Options	39
Optional Features Activation	39
Change Password.....	39
Calibration Tab	40
Calibrate the System.....	41
Calibrated Conformance Standard Test Card Preventive Maintenance Instructions..	44
Enter Test Card Parameters for a Replacement Card	44
Data Matrix Calibrated Conformance Test Card	45
Grading Tab	46
Section 1: 1D Codes	46
1. Overall Grade.....	47
2. ISO Grading	49
3. View Box	50
OCR (Human Readable Character Check)	51
Zoom	52
4. Grade Bar Graph.....	53
Bar Height Measurement	53
5. ISO/IEC Parameters Section	54
6. Blemish (Non-ISO Parameter)	55
Other Grading Screen Tools	56
Opacity	56
Color Codes	57
Height and Width Measurement.....	57

Barcode Too Wide for Field of View (Stitching Feature)	58
Section 2: Matrix Codes	63
Verify a Matrix Code	63
View Section	63
Multi-Rotation Codes	66
DataMatrix	66
QR Code	67
Section 3: Two-Dimensional Multi-Row Codes	68
Verify a PDF 417 or Micro PDF 417 Code	68
PDF417 Parameters	68
GS1 Databar Composite Verification	69
Verify a Composite Code	70
Zoom Tab	71
SRP View Tab	72
View Section	74
Full Screen Waveform	74
Traditional Bar Growth and Shrinkage	76
Traditional Parameters Button	77
Dimensional Analysis Button	78
10-Line Grading Button	78
Print Button	78
Structure Tab	79
Printing	79
Use the Data Structure Analysis	80
Data Structure Analysis Example	81
Archive Tab	82
Import Image from File	83
Export Image to File	85
Recent Reports (Last 30 Days)	86
Delete Prior to Specific Date	86
Software Version History	88
Audit Trail Report	88
Calibration Report	88
Reference Report	88
Export Reference Data	88
Change SQL Connection	89
Create Backup Database	91
Browse Backup Database	92

Print an Archived Report.....	92
Preventive Maintenance Schedule	93
LVS-9510	93
LVS-9570	93
LVS-9580	94
LVS-9505	94
LVS-9500	94

Product Discontinuation Notice

LVS-9500 Product Discontinuation

Microscan is discontinuing the LVS-9500 as of December 31st, 2011; the system will be supported for four years from December 31st, 2011 through December 31st, 2015.

Repair of the LVS-9500 is based on the availability of component parts and is at the discretion of Microscan.

LVS-9505 Product Discontinuation

Microscan is discontinuing the LVS-9505 after introduction of the LVS-9510 to the marketplace. The LVS-9505 will be supported for four years until December 31st, 2015. After discontinuation, repair of the LVS-9505 is based on the availability of component parts and is at the discretion of Microscan.

Overview

This manual covers the operating instructions for the LVS-95XX Series Barcode Verification Systems, which include the LVS-9510, LVS-9570 and LVS-9580.



LVS-9510



LVS-9570



LVS-9580

IMPORTANT: The user-supplied computer connecting to the 5.0 MP Auxiliary Readhead must be running LVS-95XX software version 3.0.8 or higher.

The standard features of the LVS-95XX system are documented in this manual. Special, upgraded features are documented in “Appendix G: Special Features.” Appendix G includes the following topics:

- Multi-Barcode Verification
- Change Verification Report to One-Column Format
- Change Verification Report Signature Lines
- Change CommPort Settings
- Automatic Login
- Windows® Lockdown
- Export Override
- Custom Reports
- Print “Data Structure Analysis Report” with “Verification Report”
- Exclude “All” (Multi-Sector or Multi-Rotation) on Export
- Account Password Reset
- Application Standard Shortcut Keys
- Decimal Grading

Appendix G is located on the installation flash drive included with your system package.

Installation Assistance

For software installation assistance with any LVS-95XX system, refer to the “LVS-95XX Series Software Installation Guide”.

The LVS-95XX system arrives to your site packaged in a specially designed shipping carton. DO NOT discard this shipping carton in case you must ship or store the system for any reason. Failure to use this carton when returning your product to Microscan will void warranty.

WARNING: All LVS-95XX systems must use the calibration card and installation flash drive issued with the system. The LVS-95XX system, calibration card and installation flash drive use the same serial number and must be used in conjunction with each other to obtain correct calibration results. Failure to use the calibration card and installation flash drive issued with the system will result in incorrect calibration results.

System Manuals

All LVS-95XX system manuals are stored in the following locations:

Installation flash drive	Each system purchase is supplied with an installation flash drive containing installation software and system manuals. See note below.
Host Computer	After successful installation of the LVS-95XX software, the system manuals are located at the paths below: Windows 7 (64-bit): C:\Program Files (x86)\I9500\Manuals Windows 7 (32-bit): C:\Program Files\I9500\Manuals Windows XP: C:\Program Files\I9500\Manuals
Computer Desktop	After installing the LVS-95XX software, an “LVS Manuals” icon is saved to the computer’s desktop. Double-click the “LVS Manuals” desktop icon to access the system manuals.

Note: When inserting the installation flash drive into the USB port with Autorun activated, screens automatically appear prompting you to install the LVS-95XX software. If you would like to view or print the manuals located on the installation flash drive **prior to installing the LVS-95XX software**, follow the steps below:

The steps below vary based on Windows® XP or Windows® 7 operating systems. Follow the instructions below based on which operating system resides on the computer running the LVS-95XX software.

Windows XP Operating Instructions

1. Press and **hold down** the SHIFT key for 30 seconds while at the same time inserting the installation flash drive into the USB port; this prevents the system from automatically launching the LVS-95XX installation files.

WARNING: You must hold down the SHIFT key for 30 seconds. Releasing the SHIFT key prior to 30 seconds will initiate the software installation process. If this occurs, eject and then re-insert the installation flash drive and follow step 1 again.

2. After 30 seconds, release the SHIFT key.
3. Open Windows Explorer and navigate to the LVS-95XX USB drive.
4. Double-click on the “Manuals.bat” file.

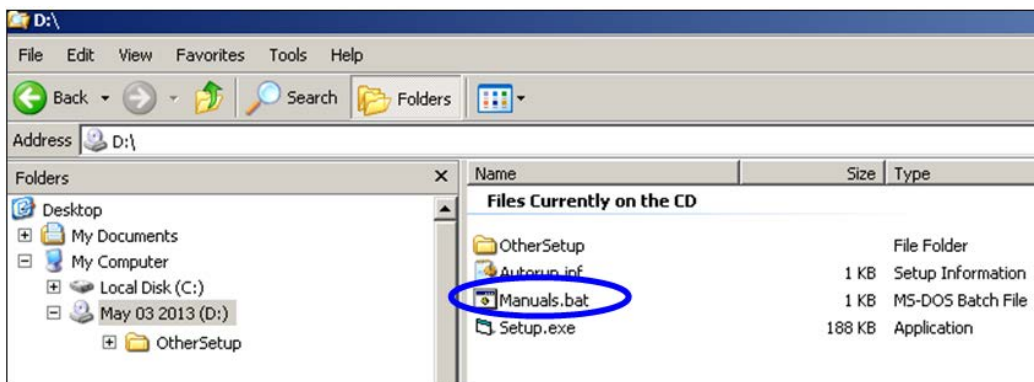

5. A window opens containing the manuals located on the installation flash drive.

Windows 7 Operating Instructions

1. Insert the installation flash drive into the USB port. The following window appears. Click “Open folder to view files.”

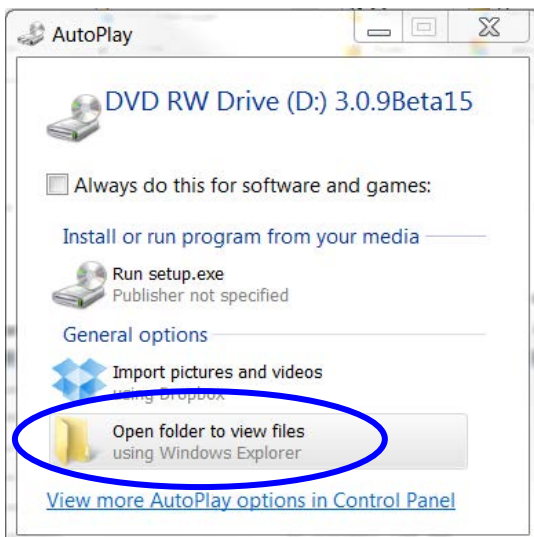

2. A window opens containing the manuals located on the flash drive.

Safety Instructions

This unit has been carefully designed to provide years of safe, reliable performance. However, as with all electrical equipment, there are some basic precautions that you should follow to avoid personal injury or damage to the system:

- Before using the system, carefully read all the installation and operating instructions.
- Observe all warning instruction labels on the system.
- To protect your system from overheating, make sure no openings on the system are blocked.
- Never insert anything into the openings of the system.
- Do not use the system near water or spill liquid into it.
- All components used to create your system are UL and CE approved. All circuits were designed to incorporate maximum safety. However, any equipment using electrical voltages may cause personal injury if improperly handled.
- Do not attempt to work on the system with the main power lines connected.
- Ensure that the AC power source matches the ratings listed for the system. If unsure, check with your dealer or local utility provider.
- Do not place the AC power cord where it can be stepped on. If the AC power cord becomes damaged or frayed, replace it immediately.
- Avoid looking directly into any system lights. If you need to examine the lights, or look at any component near the lights, be sure to first turn off the lights. If the lights cannot be turned off, then wear polarized sunglasses while examining the lights.
- To avoid damaging the system, turn off and unplug the system before cleaning.
- If the system ever needs repair, consult Microscan or your Microscan distributor.

LVS-95XX Series Software Specifications

Symbology	Supported Standard(s)
PPN (Pharmacy Product Number)	IFA Coding System / PPN-Code Specification
Code 39	ISO 16388
Interleaved 2 of 5	ISO 16390
ITF-14	ISO 16390 & GS1 General Specifications
Code-128	ISO 15417
GS1-128	ISO 15417 & GS1 General Specifications
GS1-128 with CC-A	ISO 15417, ISO 24723 & GS1 General Specifications
GS1-128 with CC-B	ISO 15417, ISO 24723 & GS1 General Specifications
GS1-128 with CC-C	ISO 15417, ISO 24723 & GS1 General Specifications
Code 93	AIM BC5
Codabar	AIM BC3
UPC-A	ISO 15420 & GS1 General Specifications
UPC-A with 2 Digit supplemental	ISO 15420 & GS1 General Specifications
UPC-A with 5 Digit supplemental	ISO 15420 & GS1 General Specifications
UPC-A with CC-A	ISO 15420, ISO 24723 & GS1 General Specifications
UPC-A with CC-B	ISO 15420, ISO 24723 & GS1 General Specifications
UPC-E	ISO 15420 & GS1 General Specifications
UPC-E with 2 Digit supplemental	ISO 15420 & GS1 General Specifications
UPC-E with 5 Digit supplemental	ISO 15420 & GS1 General Specifications
UPC-E with CC-A	ISO 15420, ISO 24723 & GS1 General Specifications
UPC-E with CC-B	ISO 15420, ISO 24723 & GS1 General Specifications
EAN-13	ISO 15420 & GS1 General Specifications
EAN-13 with 2 Digit supplemental	ISO 15420 & GS1 General Specifications
EAN-13 with 5 Digit supplemental	ISO 15420 & GS1 General Specifications
EAN-13 with CC-A	ISO 15420, ISO 24723 & GS1 General Specifications
EAN-13 with CC-B	ISO 15420, ISO 24723 & GS1 General Specifications
EAN-8	ISO 15420 & GS1 General Specifications
EAN-8 with CC-A	ISO 15420, ISO 24723 & GS1 General Specifications
EAN-8 with CC-B	ISO 15420, ISO 24723 & GS1 General Specifications
GS1 Databar – 14	ISO 24724 & GS1 General Specifications
GS1 Databar – 14 with CC-A	ISO 24724, ISO 24723 & GS1 General Specifications
GS1 Databar – 14 with CC-B	ISO 24724, ISO 24723 & GS1 General Specifications
GS1 Databar – 14 Stacked	ISO 24724 & GS1 General Specifications
GS1 Databar – 14 Stacked with CC-A	ISO 24724, ISO 24723 & GS1 General Specifications
GS1 Databar – 14 Stacked with CC-B	ISO 24724, ISO 24723 & GS1 General Specifications
GS1 Databar Limited	ISO 24724 & GS1 General Specifications
GS1 Databar Limited with CC-A	ISO 24724, ISO 24723 & GS1 General Specifications
GS1 Databar Limited with CC-B	ISO 24724, ISO 24723 & GS1 General Specifications
GS1 Databar Expanded	ISO 24724 & GS1 General Specifications
GS1 Databar Expanded CC-A	ISO 24724, ISO 24723 & GS1 General Specifications
GS1 Databar Expanded CC-B	ISO 24724, ISO 24723 & GS1 General Specifications

Symbology	Supported Standard(s)
GS1 Databar Expanded Stacked	ISO 24724 & GS1 General Specifications
GS1 Databar Expanded Stacked CC-A	ISO 24724, ISO 24723 & GS1 General Specifications
GS1 Databar Expanded Stacked CC-B	ISO 24724, ISO 24723 & GS1 General Specifications
GS1 Data Matrix	ISO 16022 & GS1 General Specifications
Data Matrix	ISO 16022
PDF-417	ISO 15438
Micro PDF-417	ISO 24728
QR Code 2005	ISO 18004
Micro QR Code 2005	ISO 18004
Aztec	ISO 24778
Laetus Pharmacode	Laetus
MaxiCode	ISO 16023
Han Xin	Draft AIM Specification

Additional Notes

- GS1 General Specifications can be obtained by contacting your local GS1 office.
- ISO Symbology Standards can be obtained from this link: <http://www.iso.org/iso/en/CatalogueListPage.CatalogueList?ICS1=35&ICS2=40&ICS3=&scopelist=>
- AIM Symbology Standards can be obtained from this link: <https://www.aimglobal.org/estore/>

In addition to adherence to the symbology specifications, the LVS-95XX systems comply with the following standards:

- ISO 15415 - Barcode print quality test specification - Two-dimensional symbols
- ISO 15416 - Barcode print quality test specification - Linear symbols
- ISO 15426-1 - Barcode verifier conformance specifications - Part 1: Linear symbols
- ISO 15426-2 - Barcode verifier conformance specification - Part 2: Two-dimensional symbols

LVS-9510 and Auxiliary Readhead Hardware Specifications

Physical Properties

Height	10.5"	266.7 mm
Width	11.125"	282 mm
Depth	9.062"	230 mm
Viewing Window	5" x 7"	127 mm x 177.79 mm
Weight	<ul style="list-style-type: none"> Unpackaged weight (standalone LVS-9510 unit) = 6 pounds (2.72 kg) Shipping weight (includes all items packaged in shipping box, such as power supply, cables, manuals, etc.) = 13 pounds (5.89 kg) 	



Video Camera

- Monochrome. 5.0 megapixel

Minimum PC Requirements (PC Supplied by User)

- Windows® XP Professional or Windows® 7 (Windows® Vista is not supported)
- Intel® Core™ 2 Duo Processor (or equivalent)
- 2 GB RAM
- 800 x 600 Resolution
- One available USB 2.0 port (additional ports required for each Auxiliary Readhead in use)
- The user-supplied computer connecting to the 5.0 MP Auxiliary Readhead must be running LVS-95XX software version 3.0.8 or higher.

Top Cover

- 5.5" x 7.5" (139.7 mm x 190.5 mm)
- Weight = 5.5 oz (162.65 grams)

Light Source

- White Light
- Red (660 nm) filter. Optional clear window available for purchase.

Inputs / Outputs

- USB 2.0 port
- Power Supply 12 vdc @ 2.5 amps (minimum)

Operating Temperature

- 10° C (50° F) to 30° C (86° F)

Storage Temperature

- 0° C (32° F) to 40° C (104° F)

Relative Humidity

- 20% to 70% (non-condensing)

Calibration

One of the following:

- EAN/UPC Calibrated Conformance Test Card
- GS1-128 Calibrated Conformance Test Card

Specifications and photos subject to change.

LVS-9570 Hardware Specifications

Physical Properties

Height		
• Verifier height	2.13"	54.10 mm
• Total height including handle	4"	101.6 mm
Length	3.94"	100.08 mm
Width	6.56"	166.62 mm
Weight	2.3 pounds	1.04 kg



Line Scan Camera

- 400 DPI
- Floating Sensor Head

Overall Scanning Width

- 5.4" (137.16 mm) in picket fence format
- Up to 12.0" (305 mm) in ladder format

Minimum X-Dimension

- 1D (Narrow Bar Width): 8.8 mils (.0088") (.223 mm)
- 2D (Cell Size): 12.5 mils (.0125") (.317 mm)

Verification

- 1D and 2D codes that comply with ISO/IEC standards and GS1 General Specifications

Minimum PC Requirements (PC Supplied by User)

- Windows® XP Professional or Windows® 7 (Windows® Vista is not supported)
- Intel® Core™ 2 Duo Processor (or equivalent)
- 2 GB RAM
- 800 x 600 Resolution
- One available USB 2.0 port

Light Source

- Red Light
- 660 nm

Inputs / Outputs

- USB 2.0 port

Operating Temperature

- 10° C (50° F) to 30° C (86° F)

Storage Temperature

- 0° C (32° F) to 40° C (104° F)

Relative Humidity

- 20% to 70% (non-condensing)

Calibration

- EAN/UPC Calibrated Conformance Test Card

Specifications and photos subject to change.

LVS-9580 Hardware Specifications

Physical Properties

Height	8.5"	215.9 mm
Width	4.75"	120.6 mm
Depth	5.5"	139.7 mm
Weight	<ul style="list-style-type: none">▪ Unpackaged Weight = 15.5 oz (.44 kg)▪ Shipping weight (includes all items packaged in shipping box, such as cables, manuals, etc.) = Approximately 4 pounds (1.81 kg)	

Imaging Device

- 5.0 mp camera
- Object Distance: Contact

Field of View

- 3.0" (76.19 mm) horizontally
- 2.25" (57.15 mm) vertically

Minimum Barcode X Dimension

- 1D = 4.0 mils (0.10 mm)
- 2D = 5.9 mils (0.15 mm)

Minimum PC Requirements (PC Supplied by Customer)

- Windows® XP Professional or Windows® 7 (Windows® Vista is not supported)
- Intel® Core™ 2 Duo Processor (or equivalent)
- 2 GB RAM
- 800 x 600 Resolution
- One available USB 2.0 port

Power Requirements

- USB Powered 5VDC @ 180mA

Light Source

- Red 660 nm filter

Communication

- USB 2.0 A/MINI-B cable 10 feet (3048 mm)



Operating and Storage Temperature

- 4° C (40° F) to 46° C (115° F)

Relative Humidity

- 5% to 95% (non-condensing)

Calibration

- EAN/UPC Calibrated Conformance Test Card

Safety Compliant

- RoHS/WEEE compliant
- CE

Specifications and photos subject to change.

LVS-9500 Hardware Specifications

Physical Properties

Height	18"	18 mm
Width	13"	330 mm
Depth	17"	432 mm
Weight	27.5 pounds	12.5 kg

Light Source

- White Light
- Red Filter
- 660 nm

Inputs / Outputs

- 3 USB ports
- 1 Serial port
- 1 External VGA port
- External USB mouse
- 10/100 LAN (Ethernet)
- 12 vdc @ 1 amp (nominal)
- 5 vdc @ 2.4 amps (nominal)

Main Power Supply

- Internal fuse (5A)
- 350 watt ATX power supply
- 50/60 hz 100 to 240 VAC

Monitor

- Built in, 12.1"
- 800 x 600 LCD Display

Video Camera

- Monochrome
- 2.1 or 1.3 Mega-pixel

Computer

- Intel-based processor
- 512 MB memory
- 40 GB hard drive (minimum)
- Windows XP Professional
- 12V @ 4.87 A5V @ 12.2 A
- Elastomer keyboard

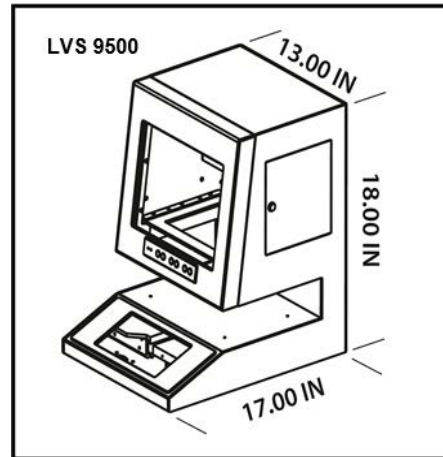

Operating and Storage Temperature

- 0°C (32°F) to 40°C (104°F)

Relative Humidity

- 20% to 70% (non-condensing)

Calibration

One of the following:

- EAN/UPC Test Card
- GS1-128 Test Card

Specifications and photos subject to change.

LVS-9505 Hardware Specifications

Light Source

- White Light
- Red Filter
- 660 nm
- 12 vdc @ 1.6 amps

Inputs / Outputs

- USB 2.0 port
- 12 vdc @ 1.10 amps

Video Camera

- Monochrome. 1.3 or 2.1 MP

Operating Temperature

- 10° C (50°F) to 30° C (86°F)

Relative Humidity

- 20% to 70% (non-condensing)

Storage Temperature

- 0° C (32°F) to 40° C (104°F)

Physical Properties

- Depth = 406 mm (16")
- Width = 330 mm (13")
- Height = 258 mm (10.14")
- Weight = 5 kg (11 lbs)

Minimum PC Requirements (PC Not Supplied)

- Windows XP Professional
- Intel Celeron 2.4 Ghz
- 512 MB RAM (1 GIG Recommended)
- 40 GB HDD
- 800 x 600 Resolution
- (2) USB 2.0 ports

Calibration

- EAN/UPC Test Card or GS1-128 Test Card

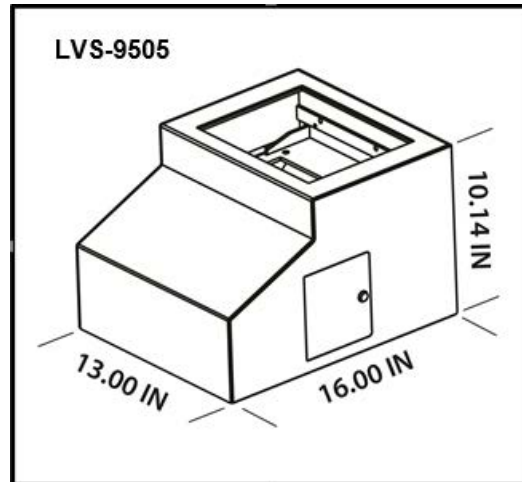

Specifications and photos subject to change.

Basic Operations

The basic operational procedures for the LVS-95XX systems are listed below:

1. Turn on the system and wait two minutes for the lights to stabilize.
2. The system is setup with tabs located across the top of the screen. Each tab is discussed in this guide.



3. Click the Setup tab and choose the desired Application standard. When prompted for an Operator ID and Password, enter admin for both the Operator ID and Password.

4. Click the **Calibration** tab and calibrate the system by placing either of the Master Grade barcodes (located on the supplied Calibration Test Card) into the center of the field of view, ensuring that the blue line passes through the "PASS" portion of the calibration label. Then, click the **Calibrate** button.

	Goal	Actual
Decodability	86.3	87
Contrast	80.8	78
Modulation	82.8	82
Rmax	89.5	87

- Click the **Grading** tab and place a barcode into the field of view. Draw a box around the PASS portion of the barcode, ensuring enough space for the quiet zone. Position the barcode as close to the center of the field of view as possible. The verification results are displayed immediately.

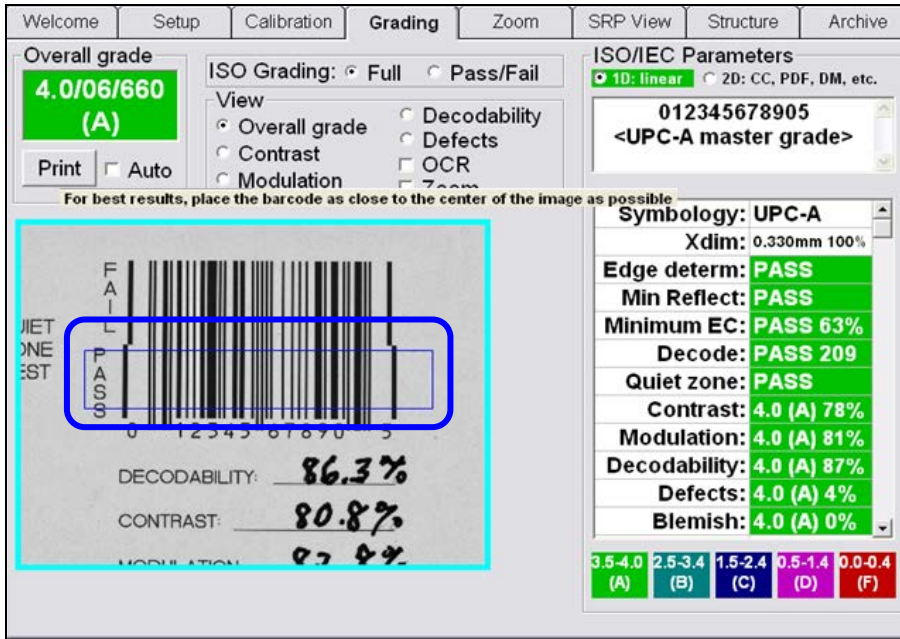

When using the LVS-9510 with a 5.0 megapixel (MP) camera, the border around the image view box turns yellow when placing an image in the field of view. A yellow border indicates that a lower resolution image is being used to easily adjust the image to its ideal position. When the ideal position is located, stop moving the image. When no motion is detected in the field of view, the image view box border turns cyan/aqua indicating that a higher resolution image is being used for barcode grading.

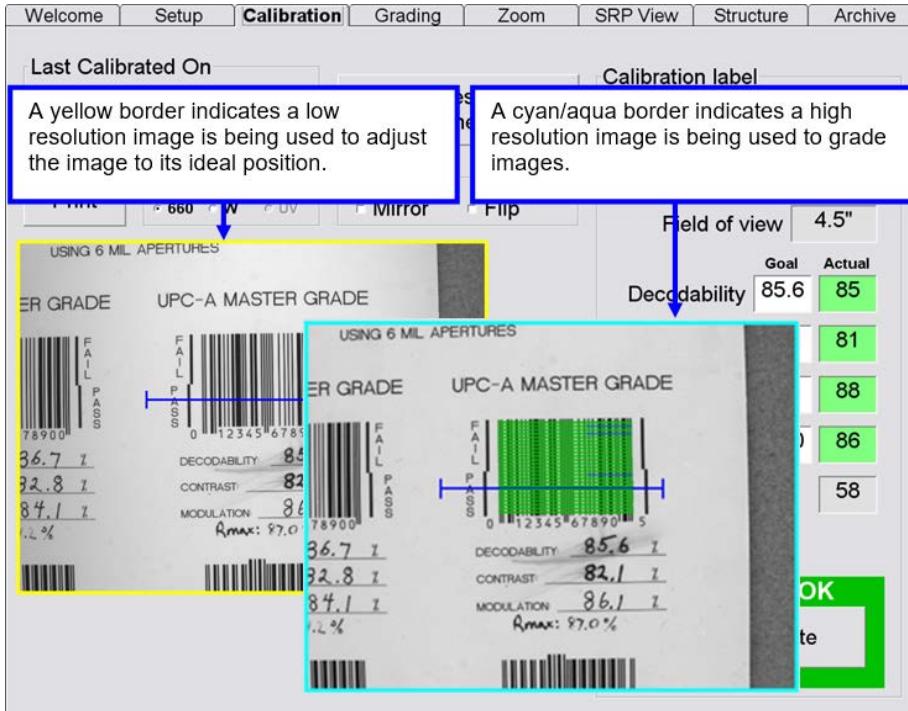

Barcodes can be verified in any orientation, which is an integer multiple of 90 degrees.

Barcodes Verified Horizontally

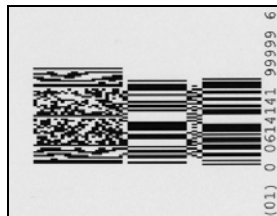
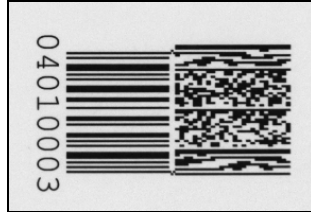

Barcodes Verified Vertically



To Print the Results

To print the verification results, click the **Print** button on the top, left corner of the **Grading Tab** screen.

To View the Report

To view the report, right-click on the **Print** button and an HTML document is generated and displayed on the screen. The HTML version can be saved as a PDF file by downloading free PDF convertor software from the Internet to the computer. Refer to the “**1. Overall Grade**” section, within the “**Grading Tab**” section of this manual for detailed instructions.

**Microscan
LVS-95XX Verification Report**

Overall: 4.0/06/660 (A)

Operator signature _____

Second signature _____

F
A
I
L

0 1 2 3 4 5 6 7 8 9 0 5

DECODABILITY: **86.3%**

CONTRAST: **80.8%**

MODULATION: **82.4%**

ID		Other information	
Symbology	UPC-A	ReportID	395
Decoded text	012345678905	Operator	admin (LVS Administrator)
Product lookup	UPC-A master grade	Application standard	GS1 General Specifications
Xdim	0.330mm 100%	Effective aperture	Reference number 06 (0.152 mm)
Edge detem	PASS	Wavelength	660nm
Min Reflect	PASS	Date and time	15-Aug-2007 10:52 local: 15-Aug-2007 14:52 GMT

This concludes the basic operations of the LVS-95XX systems. Each tab at the top of the screen is explained in detail in the following sections.

Welcome Tab

The Welcome tab is the first tab to appear when starting the LVS-95XX system.

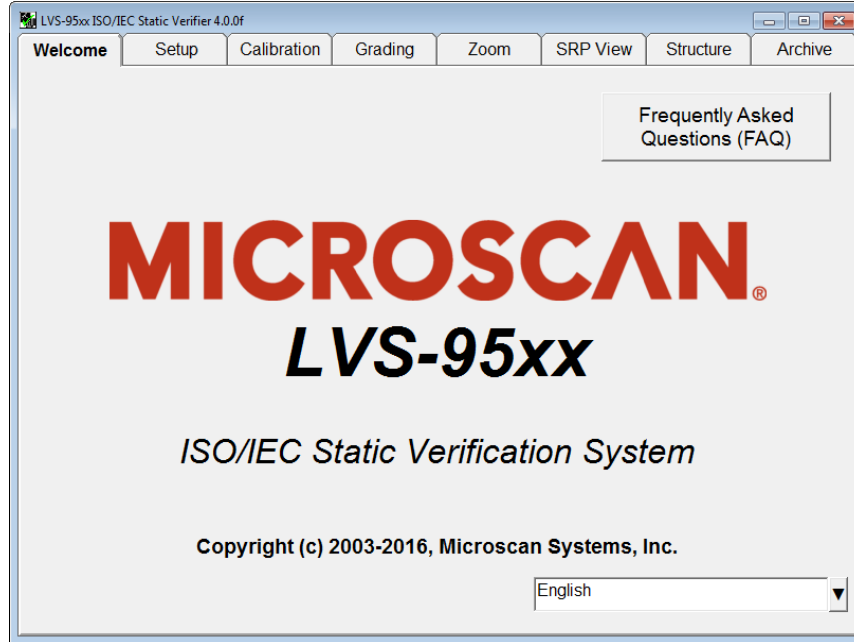

Choice of Language

1. Click the drop-down box in the lower right section of the screen to change the software language.

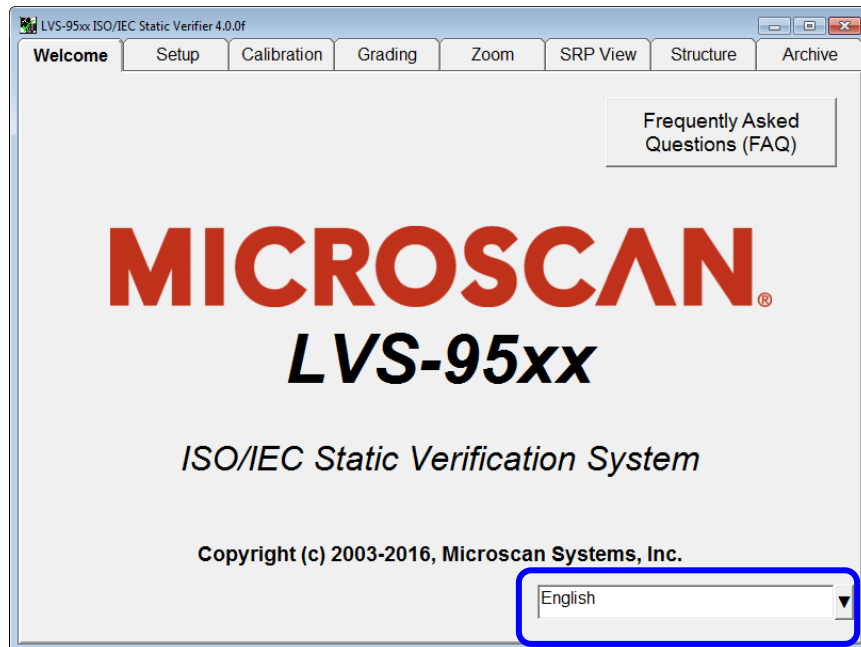

Toggling the LVS-95XX Software between Two Languages

Pressing **Ctrl + F** on the keyboard allows the LVS-95XX software to toggle between two different languages. The default condition of Ctrl + F toggles the LVS-95XX software between the currently active language and the English language.

To toggle between two languages other than English, independently log into each language then press Ctrl + F to toggle between the last two active languages. For example, to toggle between Italian (Italiano) and Spanish (Español), from the Welcome tab, select Italian (Italiano) and log in. Next, click the Welcome tab and log out. Select Spanish (Español), and log in. Pressing Ctrl + F will now toggle between Italian and Spanish.

Current Software Version List

Double-clicking on the term **Version** allows you to view a complete list of the latest software versions. After double-clicking on this term, the following page appears. This information is important if it is necessary to contact the Microscan technical helpline.

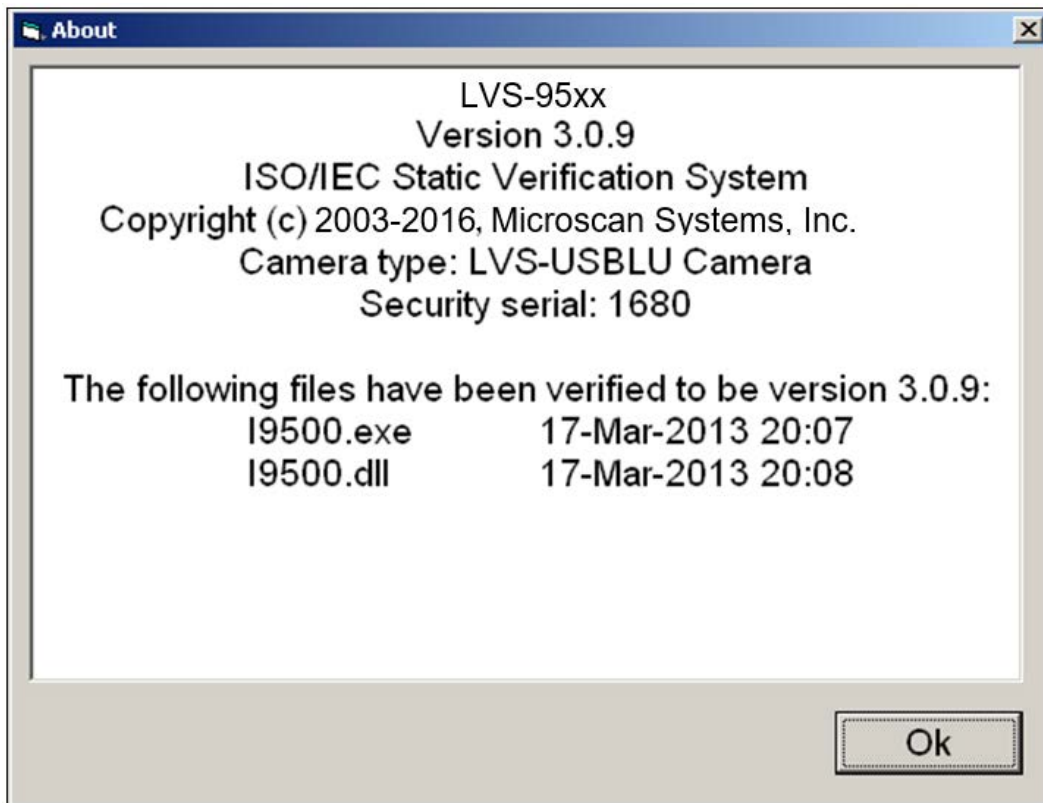

Password Login

The password Login box appears when you click on any of the tabs located at the top of the screen.

Enter the Operator ID and Password. When the system is used for the first time, the Operator ID is **admin** and the password is **admin**. This enables the administrator to gain access to where the software sets up and maintains all passwords and levels of Permissions for each operator.

The **Reference** field, which is optional, allows operators to enter a reference number for the work they are performing. This number can be used to reference a Job Number, Control Number, Purchase Order, etc.

The reference number can also be entered in the **Reference** field located on the **Setup** tab screen.

IMPORTANT: The last updated **Reference** field overrides the secondary **Reference** field. For example, a user updating the **Reference** field on the **Setup** tab screen overrides the reference number entered in the Login box.

Passwords and permission levels are explained in the next chapter under the **Setup Operators** section.

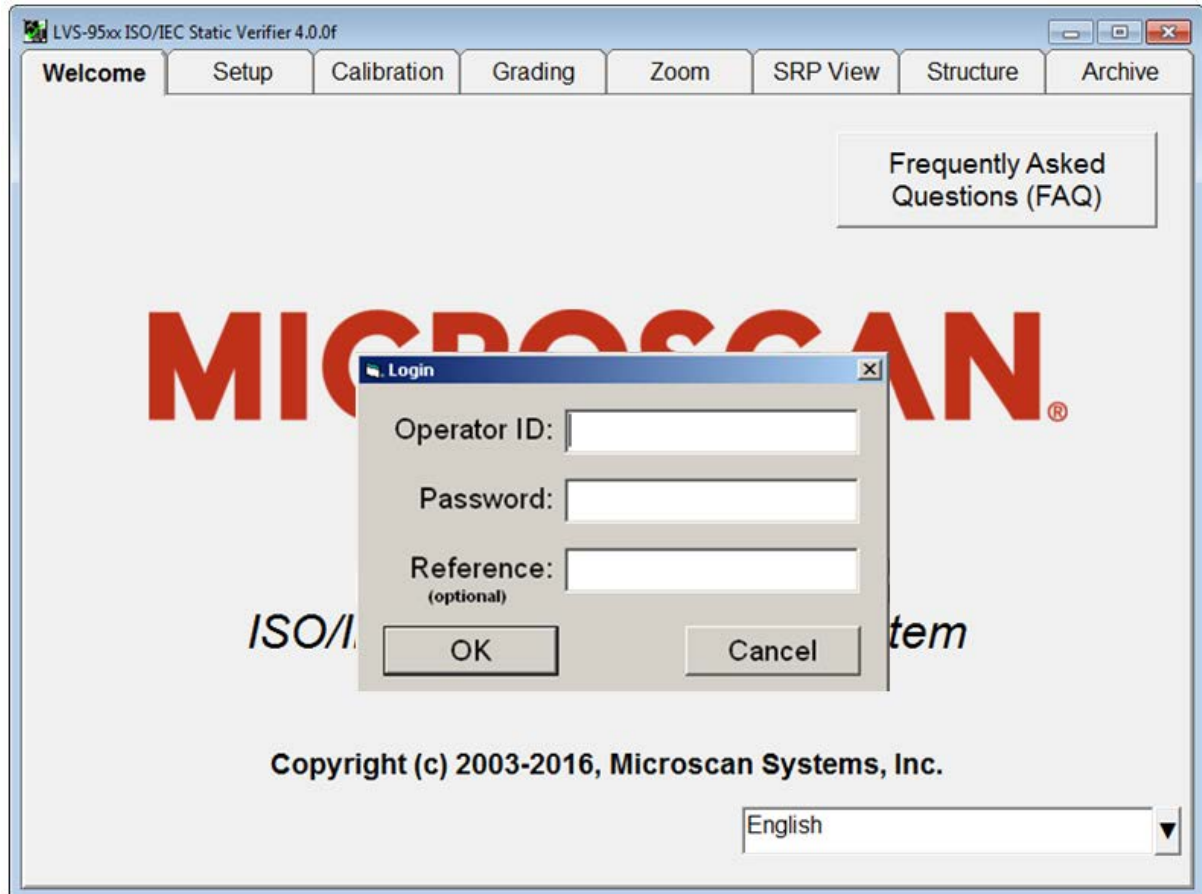

Setup Tab

The screenshot shows the 'Setup' tab of the LVS-95XX software. It features a navigation bar at the top with tabs for Welcome, Setup (selected), Calibration, Grading, Zoom, SRP View, Structure, and Archive. The main content area is organized into several sections:

- Camera:** A radio button is selected for 'Off'.
- Grading mode:** Radio buttons are selected for 'Automatic', 'Manual', and 'Auto-sector'.
- Current information:** Displays 'Local Time: 18-Mar-2013 12:50', 'GMT: 18-Mar-2013 16:50', and 'Time Zone: GMT -4'.
- Application standards:** A dropdown menu shows 'GS1 General Specifications' and a 'Configure available standards' button. An 'Override aperture' checkbox is present.
- System Settings:** Includes a 'Minimum passing score' of 2.0 with navigation arrows. Checkboxes for 'Days before password expires', 'Minutes before auto logoff', and 'Days before calibration needed' are all set to 'n/a'. There is also a checkbox for 'Allow non-ISO blemish to affect grade'.
- Optional features:** A 'List of options (choose one):' dropdown is set to 'Single sector verification (normal)', with an 'Optional Features Activation' button below it.
- Change password:** A button located at the bottom left of the main content area.
- Bottom navigation:** Three buttons labeled 'Setup operators', 'Product lookup', and 'Distributor information'.

The Setup tab contains the following sections:

- Camera
- Grading Mode
- Application Standards
- Current Information
- System Settings
- Optional Features
- Change Password button

Each of the aforementioned sections is listed below:

Camera

Select **On** to turn on the LVS-95XX system camera. Select **Off** to turn off the camera.

The camera automatically turns off when the following occurs:

- When an imported image is reviewed (see the Archive Tab section for more information).
- After performing a “stitching” operation (see the Barcode Too Wide for Field of View (Stitching Function) section for more information).

After you have finished inspecting either of the above images, the camera must be turned back **On** to see live images again.

IMPORTANT: The LVS-95XX system recognizes a maximum of three cameras plugged into a computer at one time.

See the next page for camera examples.

Options in the **Camera** section appear differently depending on the LVS-95XX systems and cameras being used. Examples include:



Camera options with an LVS-9570

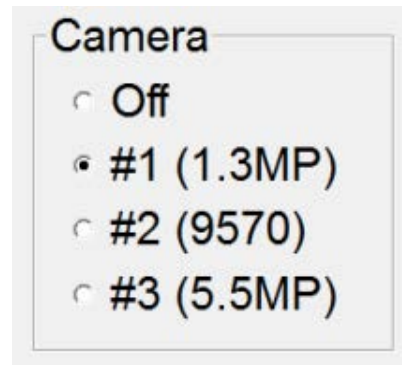

Camera options with an LVS-9570 and LVS-9510 1.3 MP and 5.5 MP cameras

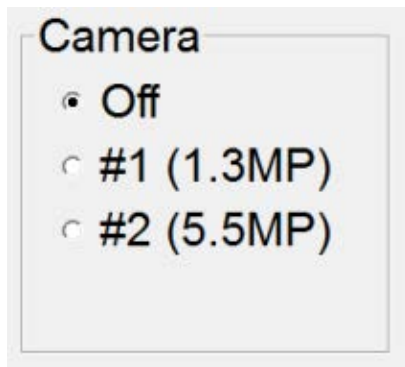

Camera options with an LVS-9510 1.3 MP camera and 5.5 MP camera

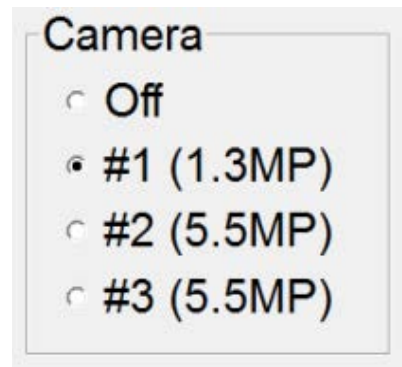

Camera options showing three LVS-9510 systems (one system with a 1.3 mp camera and two systems with a 5.5 mp camera)

Grading Mode

The “Grading Mode” section allows you to choose one of the following three ways to grade barcodes:

Note: All grading results, regardless of which grading mode is selected, are archived and viewable by clicking the “Archive” tab, and then selecting “Recent reports (last 30 days).”

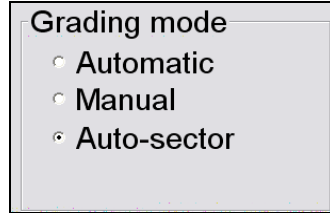

- **Automatic:** Automatic grading mode is selected typically when the user is verifying multiple barcodes of the similar dimensions. Once a sector (blue box) has been drawn, the software will detect motion and will “automatically” attempt to grade once motion has ceased. The user does not have to draw a new sector for each new barcode placed in the field of view. The sector must be drawn sufficiently large to include the required quiet zones and to allow barcodes to be easily placed in the sector but not so large as to capture unnecessary data within the reading window.
- **Manual:** After a sector has been established, you can remove the barcode and place another barcode into the field of view. Motion is detected (same as Automatic mode), however the barcode is graded after the **Click to grade** button is pushed or if a new sector is drawn.
- **Auto-sector:** The LVS-95XX software draws the sector automatically; the user does not have to draw a sector. The barcode is placed on the green “+” and when motion stops, the software detects the barcode and draws the appropriate sector around the barcode and grades the barcode. Auto-sector does a nice job detecting the barcode and drawing a sector including appropriate quiet zones; however, it is not perfect. If an incorrect sector is drawn, the user can re-draw the sector manually. Follow the steps below to use the Auto-sector feature.

Auto-Sector Feature

To use the Auto-sector feature:

1. Select "Auto-sector" on the **Setup** tab.
2. Click the **Grading** tab and notice the green + appearing in the center of the field of view.

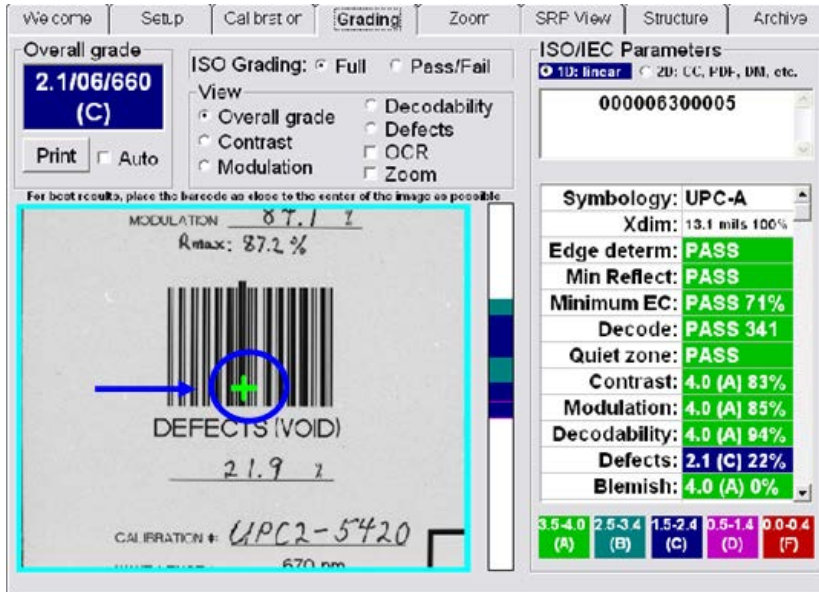

3. Position the barcode so that the green + touches any part of the barcode. The software automatically detects the barcode, draws a sector around it, and then reports the grade.

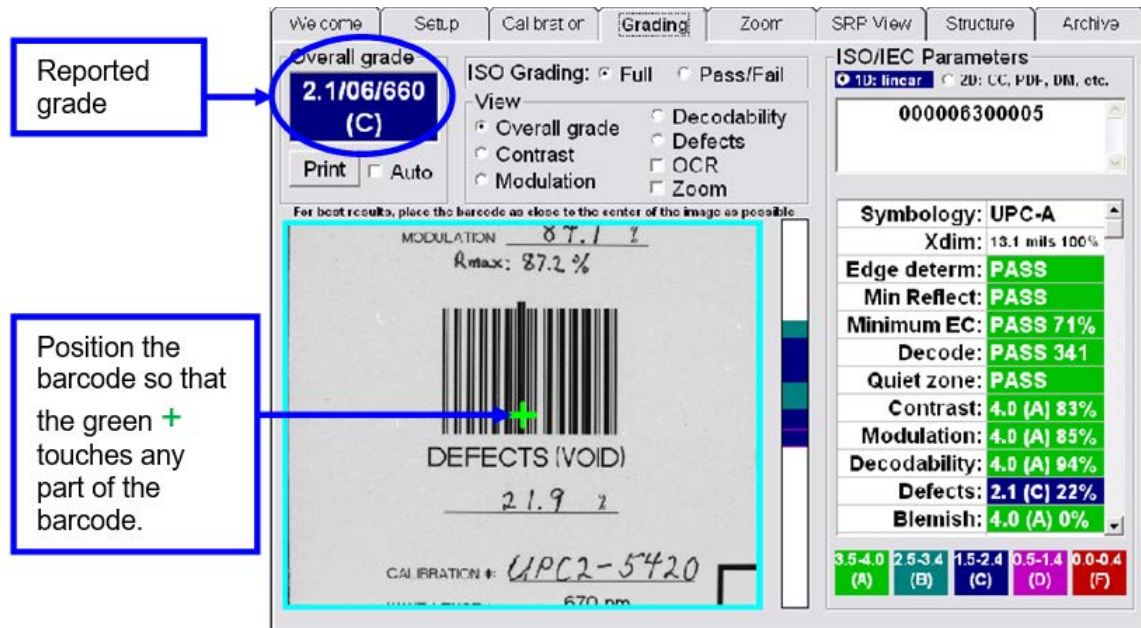

Application Standards

An Application standard is a specific protocol established by a group or industry, such as the military, hospitals, FDA, etc. Currently, the LVS-95XX Series supports the following Application standards:

- AIAG / JAMA / JAPIA / ODETTE
- ALDI
- AS9132-A / AIM DPM Cat 0
- Automatic GS1 or ISO (*read important note below*)
- Chinese Sensible (Han Xin) Code
- DHL
- FPMAJ
- French CIP
- GS1 Data Matrix including NHRN
- GS1 General Specifications
- GS1 (NTIN)
- GS1 1D Report.doc and GS1 2D Report.doc (requires the use of Microsoft® Word).
GS1 1D Report.doc and GS1 2D Report.doc are the default custom reports. You can create your own custom report(s) by following the steps outlined in Appendix G: Special Features (refer to the section entitled “Custom Reports”).
- HDMA Guidelines
- HIBC
- IFAH
- ISO/IEC 15415/15416
- Italian Pharmacode
- Japanese Codabar
- Laetus Pharmacode
- MIL-STD-130
- Miniature Pharmacode
- Multi-rotation Data Matrix
- Multi-rotation QR Code
- Postal (USPS IMB/Code 128, PostNet, Japan Post)
- PPN Code
- PZN-big, normal, small (German Pharmacode)
- PZN8

IMPORTANT: When the “Postal (Intelligent Mail, PostNet, Japan Post)” Application Standard is selected, the “SRP View” tab name changes to “Bar details” to provide an analysis report of the postal barcode.

IMPORTANT note about Automatic GS1 or ISO Application standard: When selecting the Automatic GS1 or ISO standard, the following message appears. You must read the message, enter OK in the text field, and then click OK.

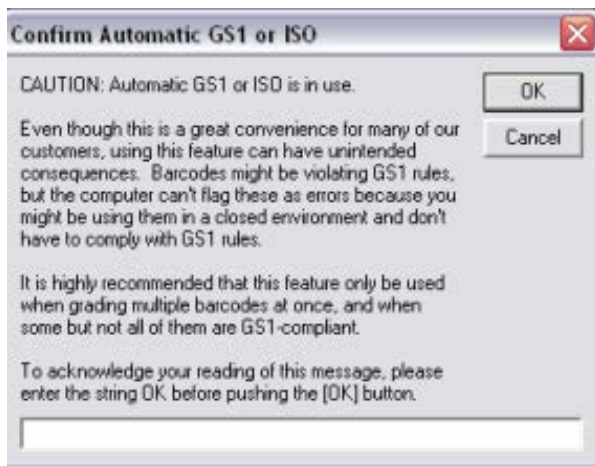

The above Application standards vary according to specific industry norms. Failure to use the correct standard causes the final grade to be incorrect. When no Application standard is specified, the ISO/IEC 15415/15416 should be used.

Selecting an Application Standard

1. Select an Application standard from the drop-down box, or click the **Configure available standards** button to view the entire list of Application standards.

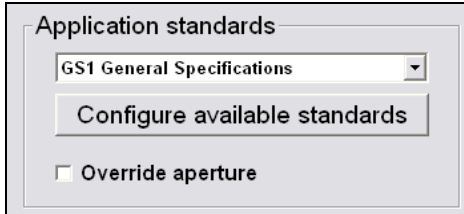

An application standard can be selected at any time by using the application standard shortcut keys. See the section below entitled “Application Standard Shortcut Keys” for more information on using application standard shortcut keys.

The Application standards appearing in the drop-down list are the standards marked **Yes** in the main Application standards window; this window appears after clicking the **Configure available standards** button (see next step for more information about this feature).

2. If you select the **Configure available standards** button, select the **Yes** checkbox for each desired Application standard. Each selected Application standard appears in the Application standards drop-down list.

Clicking the **Available** column header toggles all Application standards between Yes or No options.

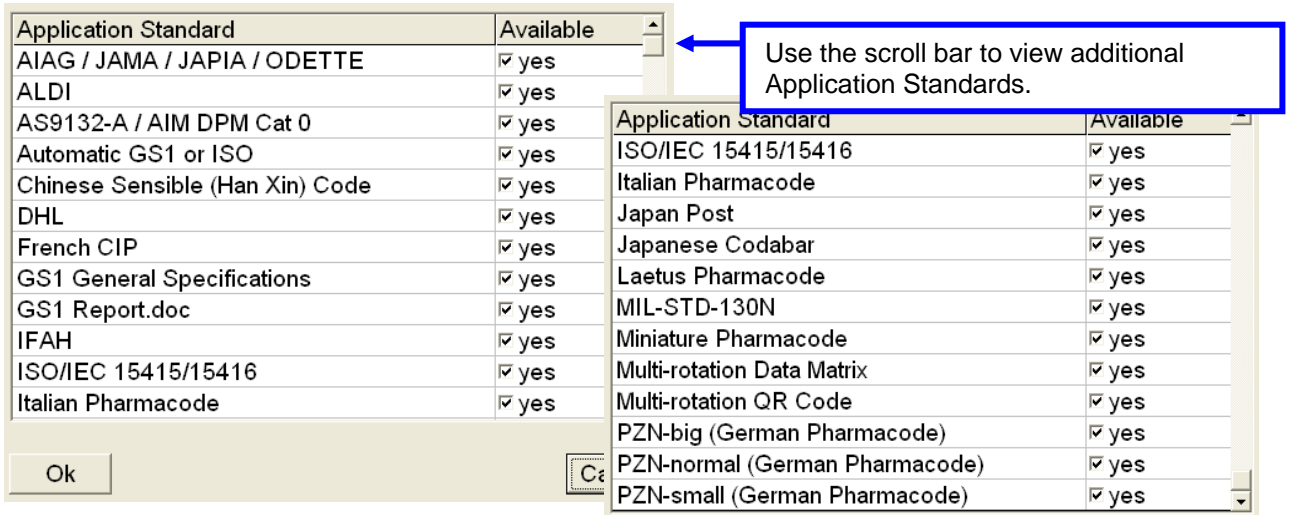

Additional Application Standards

3. Click **OK** to save your changes or **Cancel** to discard your changes.

Application Standard Shortcut Keys

The application standard currently in use is displayed in the title bar (see below). To use a different application standard, you can click the “Setup” tab and select an application standard from the “Application Standards” drop-down box, or use the keyboard shortcut keys listed in the table below to change application standards from any tab or screen. The application standards listed in the table below are the default assigned shortcut keys. See the “Application Standard Shortcut Keys” section in “Appendix G: Special Features” for instructions on assigning a shortcut key to an application standard or reassigning the default shortcut keys listed below. Appendix G is not included in this manual; it is included on the installation flash drive that arrives with your LVS-95XX system.

Note: If a sector is drawn on the “Grading” tab and you wish to change application standards, use the application standard shortcut key to switch application standards. The verification results are automatically updated using the new application standard.

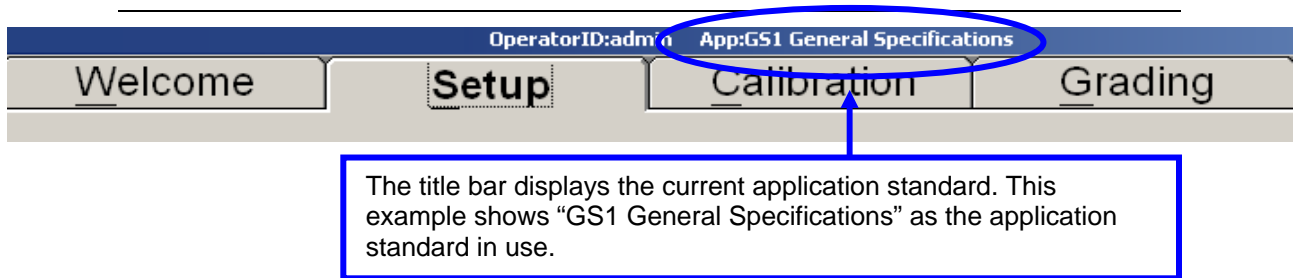

Default Shortcut Keys

Shortcut Key	Application Standard
SHIFT+A	Automatic GS1 or ISO After pressing SHIFT + A , the “Confirm Automatic GS1 or ISO” message appears. You must read the message, type “OK” in the text field, and then click the “OK” button to proceed.
SHIFT+F	FPMAJ
SHIFT+G	GS1 General Specifications
SHIFT+I	ISO/IEC 15415/15416
SHIFT+P	Postal (Intelligent Mail, PostNet, Japan Post)
SHIFT+U	USPS Code 128

Override Aperture

ISO 15415 and ISO 15416 outline rules regarding what aperture should be used based on symbology and cell size / x-dimension. ISO 15415 and ISO 15416 also state that apertures can be overridden by an Application Standard and that the Application Standard rules shall take precedence over the ISO standards. While the LVS-95XX Series supports a number of common Application Standards, it is conceivable that an aperture other than those stated either in the ISO standards or the supported Application Standards may be desired.

If an Application standard other than those specified is desired, you may override the aperture by clicking the **Override aperture** checkbox. Enter the diameter of the aperture expressed in one thousandths of an inch (.0254 mm); use this value even when using metric. If the aperture has been overridden, a clear warning is displayed on the Grading screen as well as on the Grading Report.

Creating Custom Reports

GS1 1D Report.doc and GS1 2D Report.doc are the default custom reports. You can create your own custom report(s) by following the steps outlined in Appendix G: Special Features. Refer to the section entitled "Custom Reports."

Appendix G is not included in this manual; it is included on the installation flash drive that arrives with your LVS-95XX system.

Current Information

The top-right of the **Setup Tab** screen contains a box of information indicating the local time of day, date, Greenwich Mean Time (GMT), and time zone.

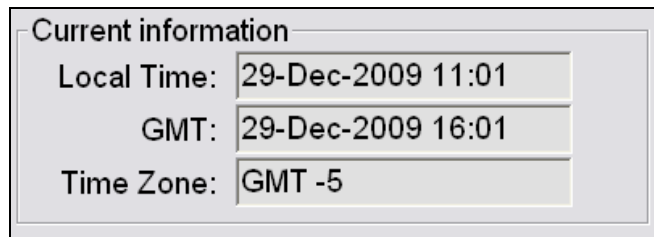

Current information	
Local Time:	29-Dec-2009 11:01
GMT:	29-Dec-2009 16:01
Time Zone:	GMT -5

GMT is defined as the local time at the 0 meridian passing through Greenwich, England and is the same as UT (Universal Time). GMT remains the same throughout the year and does not change in the Spring or Autumn. This information is attached to all Calibration Reports.

Change the Time Zone:

- Minimize the LVS-95XX screen and right click on the time box at the lower right corner of the computer screen.
- Choose Adjust Date/Time.
- Click the **Time Zone** tab and change the time zone to the correct time zone.
- Push the **Apply** button.

System Settings

The screenshot shows the 'System Settings' section of the 'Setup' tab. The 'System Settings' section is highlighted with a blue oval and includes the following controls:

- Minimum passing score: 2.0 (with arrow keys)
- Days before password expires: n/a (with arrow keys)
- Minutes before auto logoff: n/a (with arrow keys)
- Days before calibration needed: n/a (with arrow keys)
- Allow non-ISO blemish to affect grade
- Metric: Off, On
- Quiet zone processing: ORCode >1X
- Reference: [dropdown menu]
- Additional reference: [text input]
- Company name on reports: [text input]

Minimum Passing Score

There is a PASS/FAIL mode of operation used to simplify barcode verification (this is explained in more detail in the section entitled **Pass / Fail ISO Grading** in the **Grading Tab** section). This is where the minimum passing score is selected.

Days before password expires

Use the arrow keys to select the number of days before the current password expires. As soon as you use the arrow keys, the checkbox will automatically be enabled.

Minutes before auto logoff

An automatic "Logoff" feature is set by clicking on the box and then choosing a period of time desired to make the system automatically log off after that period of time. Choosing **n/a** causes this feature to be turned off.

Days before calibration needed

It is important to calibrate the system over a period of time. This feature sets up the desired number of days between system calibration. When the period of time has been reached, the software will not allow you to continue until calibration has been completed.

Allow Non-ISO blemish to affect grade

If this option is not checked, a barcode where many lines are not decodable will not be penalized since the ISO standard does not mandate how long decoded lines should be handled.

If this option is checked, non-decoded lines will degrade the overall ISO grade.

Metric

The Metric option allows you to choose between measurements being reported in inches or metric units (mm/microns).

Quiet zone processing

The **Quiet Zone** for a linear (1D) code is a clear space preceding the start character of a barcode symbol and a clear space following the stop character. The quiet zone for a two-dimensional (2D) code is a clear region (free of markings or text) surrounding the 2D symbol's finder patterns (finder patterns allow the symbol's location and orientation to be determined). Quiet zones are part of the barcode and the appropriate quiet zone space is required to verify a barcode.

The **QRCode > 1X** option toggles the quiet zone processing between 1X (where X is the nominal cell width) and greater than 1X depending on the QR symbol being graded. The QRCode > 1X option is disabled (unchecked) by default indicating the quiet zone for a QR code is one cell width around the perimeter of the finder patterns.

When checked, the LVS-95XX software uses 2X (two cell widths around the perimeter of the finder patterns) as the quiet zone for Micro Code QR symbols and 4X (four cell width) as the quiet zone for QR code symbols. ISO/IEC rules state 2X and 4X are the quiet zone requirements for Micro QR Code and QR Code respectively. Checking the **QRCode > 1X** option ensures ISO/IEC quiet zone compliance for QR Code and Micro QR code.

Example Linear (1D) Barcode Quiet Zones



Example Two-Dimensional (2D) Quiet Zones

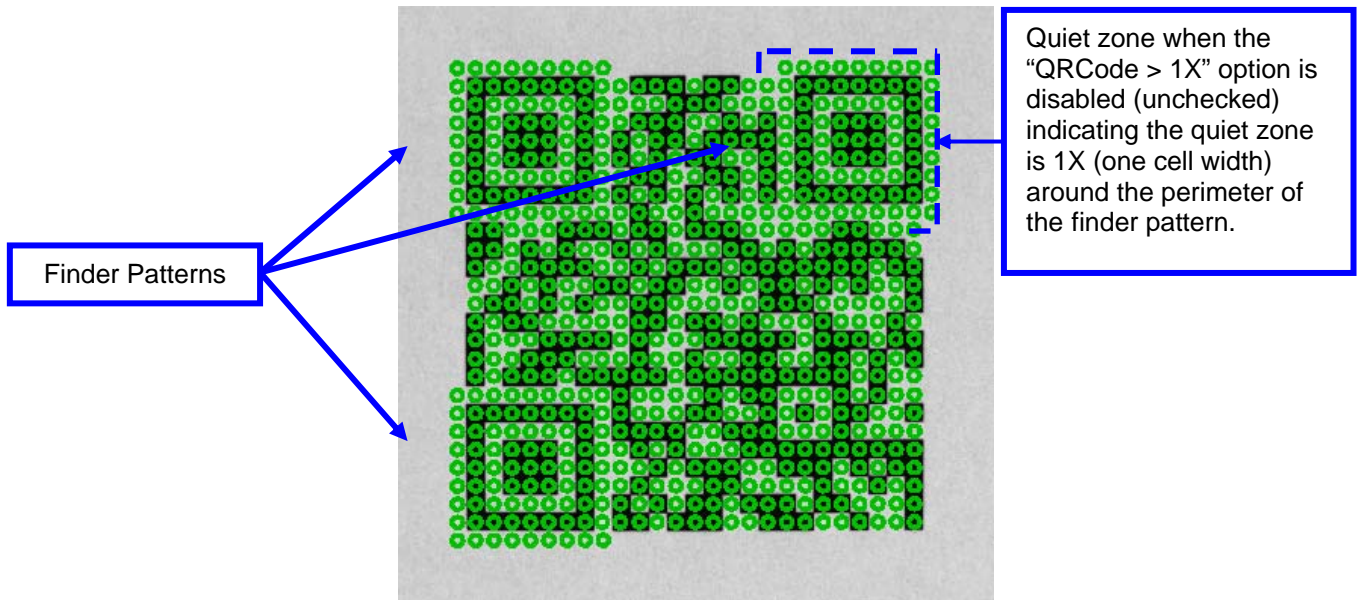

1X Quiet Zone

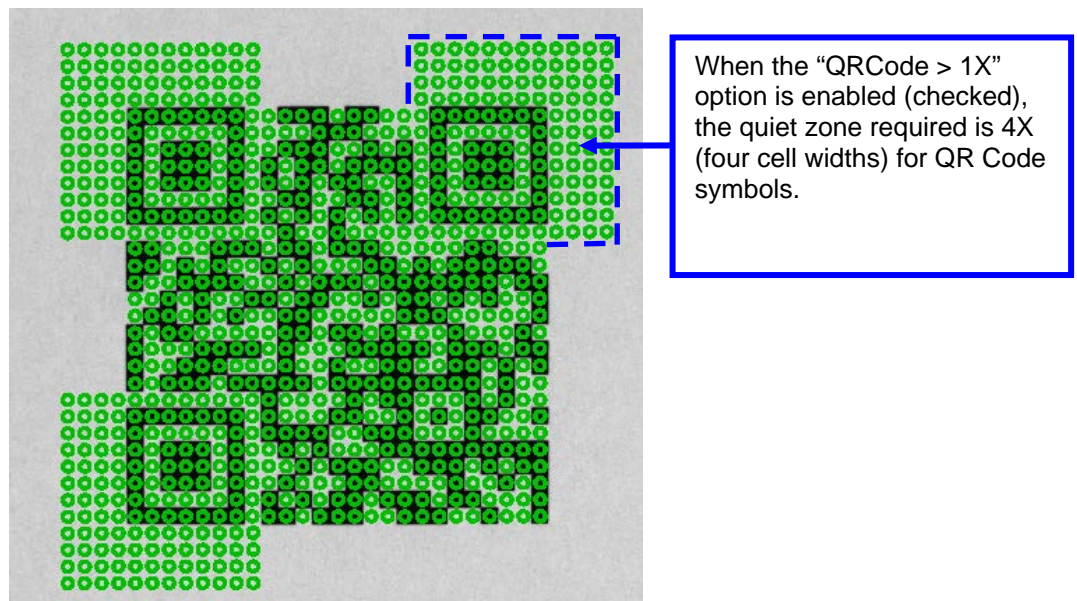

4X Quiet Zone for QR Code symbol

Reference

You can choose to add a reference number to a final verification report by entering a number in this box, such as a Job Number, Control Number, Purchase Order Number, etc; this allows you to sort results by reference.

A reference number can also be entered in the Login box when a user logs onto the system. The last updated **Reference** field overrides the secondary **Reference** field. For example, a user updating the **Reference** field in the Login box overrides the reference number entered on the Setup tab screen.

Additional Reference

The Additional Reference field is a place to tag verification events with additional information if desired. The information entered in this field will print on the report and be available in the database if the grading results are revisited in the future. An example may be a user who processes multiple rolls for a particular job. In this example, the user might choose to place the job name in the “Reference” field and the roll number in the “Additional Reference” field.

Company Name on Reports

This feature gives you the ability to place your company name on all final verification reports. Delete the default company name from the field and type in your company name.

Setup Operators

Many national and international standards stipulate that the operator of a verification system must be identified in order for the verification process to be valid. To set this up, push the **Setup operators** button.

The administrator of the system can now choose to add, delete, or change an operator’s name and password.

A password must have a minimum number of 8 characters and must contain at least (1) alpha character and (1) numeric character.

This is also where the administrator of the system chooses which operators have permission to perform the listed tasks. Be sure to push the **OK** button when you are finished entering new users or updating levels of permissions. Following is a list of permissions and descriptions:

Permission	Description
Allow Add/Change operator	Allows the administrator to assign Permission levels for all other system users. All new systems are shipped with the User Name and Password set to admin .
Allow Calibration	Allows the operator to calibrate the system.
Allow Change Setup Options	Allows the operator access to set any of the Setup Tab screen parameters.
Allow Pass / Fail ISO	On the Grading Tab , there is a section entitled ISO Grading in which you can choose between Full or Pass/Fail . This permission allows the user to set different Pass / Fail levels. For more information, refer to the section entitled Pass / Fail ISO Grading in the Grading Tab section.
Allow Full ISO	On the Grading Tab , there is a section entitled ISO Grading in which you can choose between Full or Pass/Fail . This permission allows the user to set different Pass / Fail levels. For more information, refer to the section entitled Pass / Fail ISO Grading in the Grading Tab section.
Allow Create or Edit App	<i>This feature is enabled only with a purchase upgrade.</i> Allows the user to create or edit special features, such as allowing the user to verify multiple barcodes simultaneously within the field of view. See the Optional Features – Multi-Barcode Verification section for more information.
Allow Change Archive File	Allows the user to change the backup database file located on the Archive Tab .

Product Lookup

The **Product Lookup** button is a product identification feature that allows you to enter a product code and description into a database table that reports the information each time the software decodes that string of data.

The Product Identification Data appears below the barcode data on the Grading Tab screen. The software groups this data within special characters < and >.

The software is setup to accept manual entry of data and the ability to import a CSV (comma separated values) file. The first field contains the barcode data and the next field contains its description.

The screenshot shows the 'Setup' tab of the software interface. The interface is divided into several sections:

- Camera:** A radio button for 'Off' is selected.
- Grading mode:** Radio buttons for 'Automatic', 'Manual', and 'Auto-sector' are present, with 'Automatic' selected.
- Current information:** Displays 'Local Time: 18-Mar-2013 12:50', 'GMT: 18-Mar-2013 16:50', and 'Time Zone: GMT -4'.
- Application standards:** A dropdown menu shows 'GS1 General Specifications'. Below it is a 'Configure available standards' button and an 'Override aperture' checkbox.
- Optional features:** A section titled 'List of options (choose one):' with a dropdown menu showing 'Single sector verification (normal)'. Below it is an 'Optional Features Activation' button.
- System Settings:** Includes a 'Minimum passing score' field set to '2.0', and checkboxes for 'Days before password expires', 'Minutes before auto logoff', 'Days before calibration needed', and 'Allow non-ISO blemish to affect grade'. It also has a 'Metric' section with 'Off' selected and 'On' as an option, and a 'Quiet zone processing' section with a checkbox for 'QRCode >1X'.
- Reference and Company name:** Fields for 'Reference:', 'Additional reference:', and 'Company name on reports:'.
- Buttons:** At the bottom, there are buttons for 'Setup operators', 'Product lookup' (circled in blue), and 'Distributor information'. A 'Change password' button is also visible.

Distributor Information

The **Distributor Information** button allows the distributor of this LVS-95XX system to enter his/her name, address, and phone number so that it appears on the Final Verification Report.

Optional Features

This section allows you to select your preferred verification method and to activate optional features.

List of Options

Select “Single sector verification (normal)” or “Multiple sectors verification” from the drop-down list.

- The “Single sector verification (normal)” option is the default option.
- “Multiple sectors verification” allows you to verify multiple barcode images in the field of view at the same time. This feature is an upgraded feature and is an additional cost to customers. Multiple sectors verification steps are outlined in “Appendix G: Special Features.” Contact Microscan or a Microscan distributor for more information.

Optional Features Activation

Click this button to view a list of optional features and the status of each feature:



Feature	Status
base product	security serial number 683
Custom applications (multi-sector)	activated
Automatic login	not available (click here to enter activation code)

Available options include:

Feature	Function	Status
LVS-95XX base product	Initial activation of software.	This feature is enabled by default.
Custom applications (multi-sector)	Allows you to draw multiple sectors at one time on the Grading Tab screen.	This feature is enabled only with purchase upgrade.
Automatic Login	Allows you to log on to the LVS-95XX without entering an Operator ID and Password. This feature voids 21 CFR Part 11 compliance.	This feature is enabled only with purchase upgrade.

Change Password

Click the “Change Password” box to change a password.

Calibration Tab

The Calibration tab is where the calibration of the system occurs.

The screenshot shows the Calibration Tab interface with the following elements:

- Navigation Tabs:** Welcome, Setup, **Calibration**, Grading, Zoom, SRP View, Structure, Archive.
- Last Calibrated On:** 29-Dec-2009 11:07 local, 29-Dec-2009 16:07 GMT.
- Buttons:** Enter test card parameters, Print, Show instructions.
- Calibration label:**
 - Mils: 13
 - Effective aperture: 06
 - Field of view: 2.9"
- Performance Metrics Table:**

	Goal	Actual
Decodability	86.6	88
Contrast	80.8	81
Modulation	84.6	83
Rmax	89.0	89
- Test Card:** A barcode labeled "UPC-A MASTER GRADE" with a "QUIET ZONE TEST" and "FAIL PASS" indicators. Handwritten values for Decodability (86.6%), Contrast (80.8%), and Modulation (84.6%) are visible.
- Calibration Status:** A green "Calibration OK" banner and a "Calibrate" button.

One of the following two Calibrated Conformance Standard Test Cards were supplied with your LVS-95XX system. The test card you receive depends on your field of view.

- GS1-128
- EAN/UPC Symbol Verifiers

The Calibrated Conformance Standard Test Cards are used to certify that the system is calibrated according to the ISO/IEC 15416:2000(E) and is traceable to NIST standards. It is specially printed to have certain reflective values. **The LVS-95XX system recognizes only these cards for calibration.**

The upper left corner of the **Calibration Tab** screen shows the date/time stamp that is placed on an internal log designed to archive all calibration activities. It lists a date/time stamp along with the person who performed the calibration. This report can be viewed or printed. The log is a "read-only" file and cannot be altered or deleted. To view the calibration log, go to the **Archive Tab** screen. Clicking the **Print** button prints a copy of this screen.

Calibrate the System

- To calibrate the system, click the Calibration tab. A Login pop-up window appears prompting for a user name and password. Enter your user name and password, and then click the OK button.
If the user has not been granted permission rights to calibrate the system, an error message appears indicating that the user is not able to access the Calibration tab.
- Locate the Calibrated Conformance Standard Test Card assigned to your system. Choose one of the Master Grade barcodes and place it so the blue line goes through the middle of the PASS portion of the barcode. The blue line helps you align the calibration label to the field of view; it does not mean that only one line is being used to calibrate the system.
- After placing the calibration card in position, check to be sure the goal values match the values printed on the calibration card. If they do not match you have the wrong calibration card for the system or you have to change the goal values. See section "Replacement of Calibrated Conformance Standard Test Card."

Welcome	Setup	Calibration	Grading	Zoom	SRP View	Structure	Archive
---------	-------	--------------------	---------	------	----------	-----------	---------

Last Calibrated On
29-Dec-2009 11:07 local
29-Dec-2009 16:07 GMT

Print

Enter test card parameters

Show instructions

Calibration label

Mils

Effective aperture

Field of view

	Goal	Actual
Decodability	86.6	88
Contrast	80.8	81
Modulation	84.6	83
Rmax	89.0	89

Calibration OK

Calibrate

UFC-A MASTER GRADE

QUIET ZONE TEST

F
A
I
L



P
A
S
S

0 1 2 3 4 5 6 7 8 9 0 5

DECODABILITY: 86.6%

CONTRAST: 80.8%

MODULATION: 84.6%

When using the LVS-9510 with a 5.0 megapixel (MP) camera, the border around the image view box turns yellow when placing an image in the field of view. A yellow border indicates that a lower resolution image is being used to easily adjust the image to its ideal position. When the ideal position is located, stop moving the image. When no motion is detected in the field of view, the image view box border turns cyan/aqua indicating that a higher resolution image is being used for barcode grading.

Welcome Setup **Calibration** Grading Zoom SRP View Structure Archive

Last Calibrated On

A yellow border indicates a low resolution image is being used to adjust the image to its ideal position.

A cyan/aqua border indicates a high resolution image is being used to grade images.

Print 660 UV Mirror Flip

Field of view 4.5"

Decodability Goal Actual 85.6 85

USING 6 MIL APERTURES

ER GRADE	UPC-A MASTER GRADE
 FAIL PASS 78900 36.7 % 32.8 % 84.1 % 1.2 %	 FAIL PASS 0 12345 67890 5 DECODABILITY: 85.6 % CONTRAST: 82.1 % MODULATION: 86.1 % Rmax: 97.0 %

USING 6 MIL APERTURES

ER GRADE	UPC-A MASTER GRADE
 FAIL PASS 78900 36.7 % 32.8 % 84.1 % 1.2 %	 FAIL PASS 0 12345 67890 5 DECODABILITY: 85.6 % CONTRAST: 82.1 % MODULATION: 86.1 % Rmax: 97.0 %

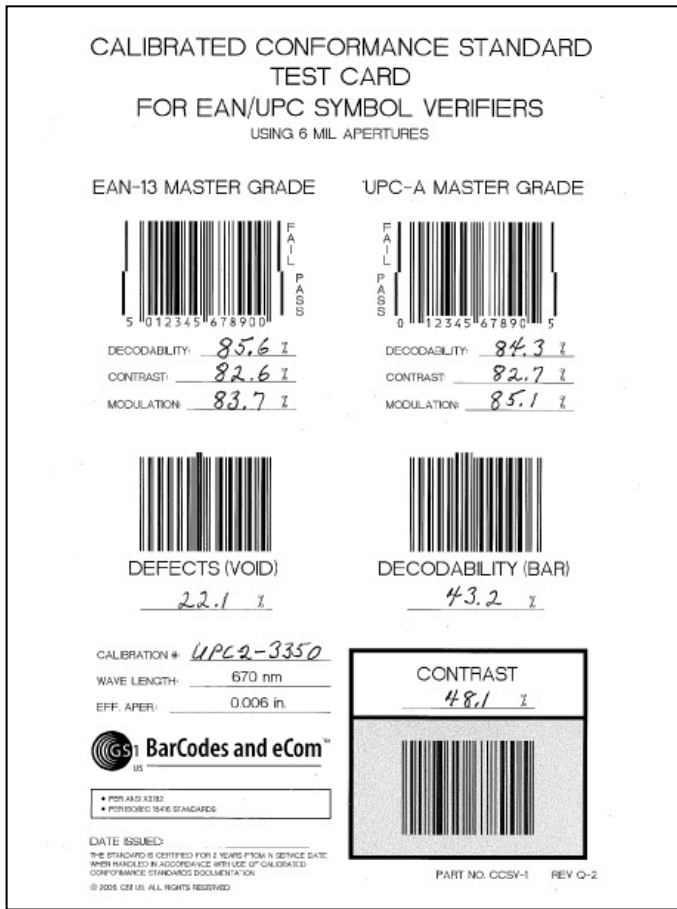

EAN/UPC Calibrated Conformance Standard Test Card

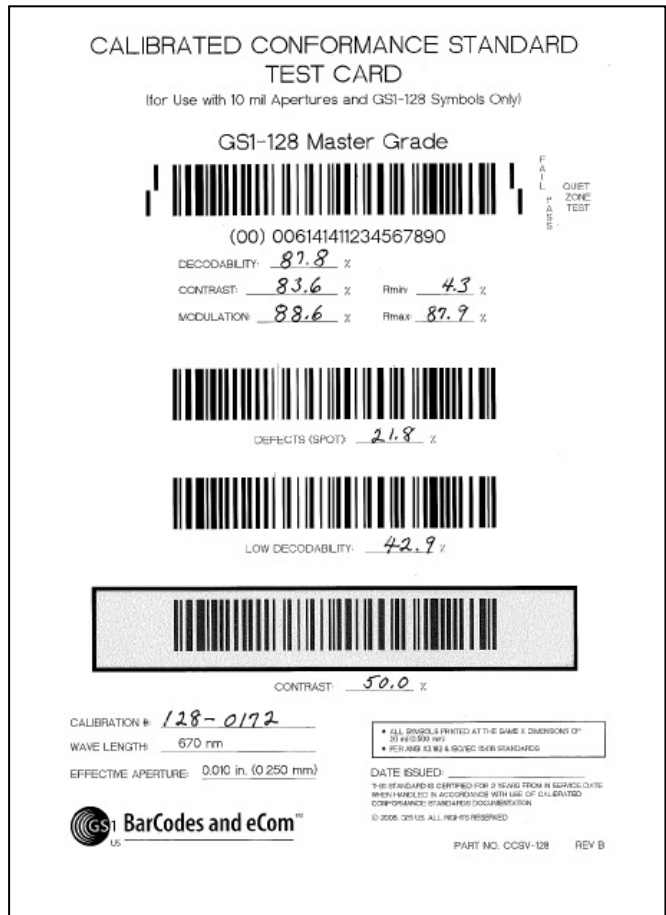

GS1-128 Calibrated Conformance Standard Test Card

The Calibration Test Card is used to calibrate the light source to a known level of white and black. There cannot be any other item in the field of view when calibration takes place. Failure to comply with these instructions will distort the final verification grade.

To correctly calibrate, the Calibration Test Card must be flat. Use magnets or weights, if necessary, to hold the card down flat. The magnets or weights must not appear in the field of view.

The image may appear too light or too dark; this is to be expected. Please do not attempt to make any adjustments on the lens assembly; it has already been set at the factory and does not require adjustment. The software automatically adjusts to the proper brightness level.

4. Press the **Calibrate** button. The system begins the calibration process. The calibration result could be either of the following:
 - **Calibration OK:** Calibration is correct and the system is ready to use. You can recalibrate if you like, but the new values are very close to the existing ones.
 - **Calibration Failed:** The system is too dark or too bright for calibration. When this message is displayed, try to calibrate again. It may be necessary to recalibrate a couple of times as the software is trying to adjust to the current ambient light conditions. Be sure there is no direct light shining on the viewing stage. If the message "Unable to Calibrate" continues to be reported, call Microscan.

Calibrated Conformance Standard Test Card Preventive Maintenance Instructions

Place the Calibration Test Card in a clean place and away from direct sunlight. If the test card is nicked, soiled, or damaged in any way, it must be replaced. Contact Microscan or your Microscan representative to obtain a new Calibration Test Card.

Calibration Test Cards are valid for two years from the date entered in the "Date issued" field on the Test Card. Valid test cards are required to obtain accurate grading results.

Each calibration card has been tested by a NIST traceable test device and the values for Decodability, Contrast, Modulation and Rmax are recorded on the card.

Enter Test Card Parameters for a Replacement Card

- Click the **Enter test card parameters** button on the **Calibration Tab** screen. Click the **OK** button when a warning box appears.
- Enter the values for Decodability, Contrast, Modulation and Rmax in the gold fields located under the column entitled "Actual."
- Place the new Test Card into the field of view and push the **Calibrate** button. If calibration fails, push the **Calibrate** button again. If calibration fails repeatedly, call Microscan.

Data Matrix Calibrated Conformance Test Card

The ISO/IEC Data Matrix and GS1 Data Matrix Calibrated Conformance Test Card was developed as part of the overall development of the “2D Judge”; **IT IS NOT A CALIBRATION CARD**. The purpose of the card is to “verify the verifier” in order to prove that the verifier correlates with the results reported by the “2D Judge” within the tolerances stated in ISO 15426-2.

The purchase of the Data Matrix Calibrated Conformance Test Card is optional. If you wish to purchase a card, please contact Microscan or a Microscan representative.

IMPORTANT: Please read the document entitled “Read Me First” included with the Data Matrix test card as it provides detailed instructions about the test card.

Purchased cards are certified for up to 2 years from the “in service” date and no more than 4 years from the “date processed”, both of which are shown on the card.

ISO/IEC Data Matrix & GS1 DataMatrix
CALIBRATED CONFORMANCE STANDARD TEST CARD



1. SC, ANU, GNU - 4 (A)
X=0,500 mm (0.0197 in)



2. ANU - 1 (D)
X=0,500 mm (0.0197 in)



3. GNU - 1 (D)
X=0,500 mm (0.0197 in)



4. SC - 1 (D)
X=0,500 mm (0.0197 in)



5. Contrast Uniformity
X=0,360 mm (0.0142 in)



6. UEC - 2 (C)
X=0,360 mm (0.0142 in)



7. FPD - 2 (C)
X=0,360 mm (0.0142 in)

Serial Number: 1211
Date Processed: 14-Dec-2009
 Wavelength: 660 nm
 Synthetic Aperture: 0.8 x-Dim

<p>Symbol 1: 4.0 (A) SC - 79.2 % Rmax - 82.6 % Rmin - 3.4 % ANU - 0.1 % GNU - 3.3 %</p> <p>Symbol 2: 1.0 (D) ANU - 11.0 %</p> <p>Symbol 3: 1.0 (D) GNU - 69.0 %</p>	<p>Symbol 4: 1.0 (D) SC - 32.3 % Rmax - 35.5 % Rmin - 3.2 %</p> <p>Symbol 5: 4.0 (A) Contrast Uniformity - 31.6 %</p> <p>Symbol 6: 2.0 (C) UEC - 0.43</p> <p>Symbol 7: 2.0 (C) FPD - 2.0</p>
---	--



Copyright © 2009 GS1 US
All Rights Reserved

2D JUDGE™ CERTIFIED

PCN: 134612013523

THIS STANDARD IS CERTIFIED FOR UP TO 2 YEARS FROM THE IN-SERVICE DATE BUT NO MORE THAN 4 YEARS FROM THE DATE PROCESSED AS SHOWN ON THE ADJACENT LABEL WHEN MAINTAINED IN ACCORDANCE WITH GS1 US CALIBRATED CONFORMANCE STANDARD DOCUMENTATION

IN-SERVICE DATE

EXP. DATE



P/N CCSV-DMGS1 Rev. A
GTIN 00614141013458

ISO/IEC Data Matrix and GS1 Data Matrix Calibrated Conformance Test Card

Grading Tab

Because parameters are different for each of the families of codes, please refer to the separate sections that follow in this manual.

Section 1: 1D Codes

The screenshot shows the 'Grading' tab interface with the following sections and parameters:

- Overall grade:** 4.0/06/660 (A)
- ISO Grading:** Full (selected), Pass/Fail
- View:** Overall grade, Contrast, Modulation, Decodability, Defects, OCR, Zoom
- Grade bar graph:** A vertical bar graph showing the current grade level.
- ISO/IEC Parameters:**
 - 1D: linear (selected), 2D: CC, PDF, DM, etc.
 - Barcode: 614141999996
 - Symbology: UPC-A
 - Xdim: 12.8 mils 98%
 - Edge determ: PASS
 - Min Reflect: PASS
 - Minimum EC: PASS 67%
 - Decode: PASS 314
 - Quiet zone: PASS
 - Contrast: 4.0 (A) 83%
 - Modulation: 4.0 (A) 81%
 - Decodability: 4.0 (A) 72%
 - Defects: 4.0 (A) 6%
 - Blemish: 4.0 (A) 0%
- Blemish parameter:** 4.0 (A) 0%

The Grading tab is divided into the following sections:

1. Overall Grade
2. ISO Grading
3. View
4. Grade bar graph
5. ISO/IEC Parameters
6. Blemish (Blemish is not an ISO grade and is for informational purposes only).

Each section is described in the following pages.

1. Overall Grade

The Overall Grade box represents the final results obtained from all the data listed on the screen. Options include:

- **Auto checkbox:** Selecting this option automatically sends the Grading report to the default printer each time a new barcode is graded.
- **Print Button:** Clicking this button sends the Grading report to the default printer. Right-click on the **Print** button to view an HTML version of the Verification report. The HTML version can be saved as a PDF file by downloading free PDF convertor software from the Internet to the computer.

If PDF convertor software is downloaded to the computer, follow the steps below:

1. Click **File**, and then **Print** from the Verification report.

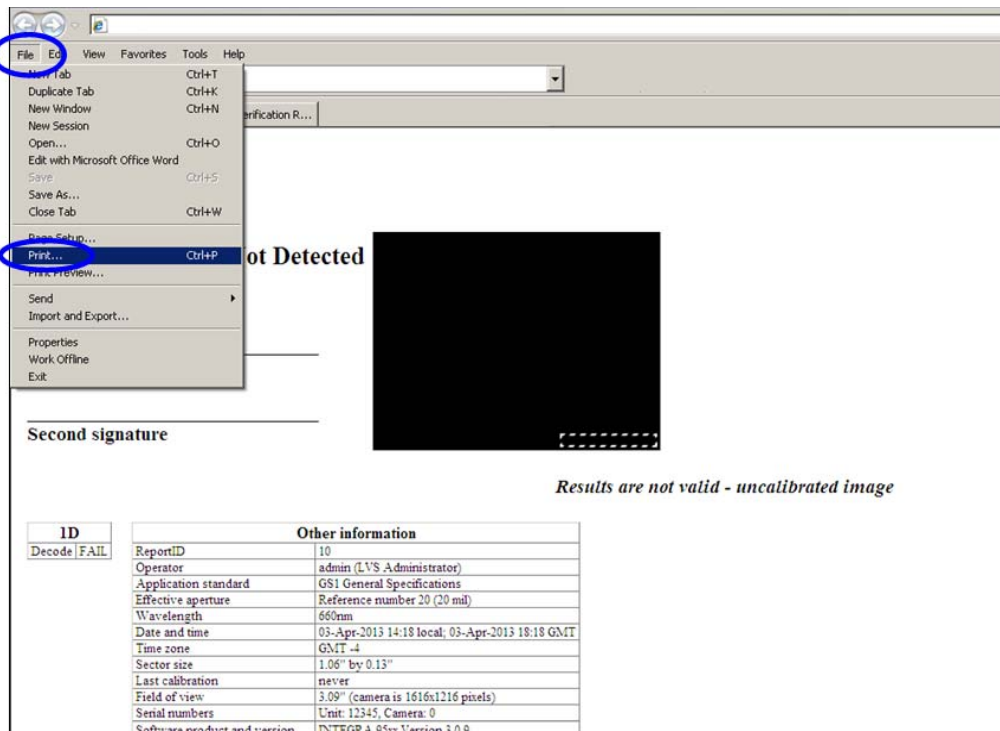

2. Select the PDF generator from the list of printers, and then click **Print**.

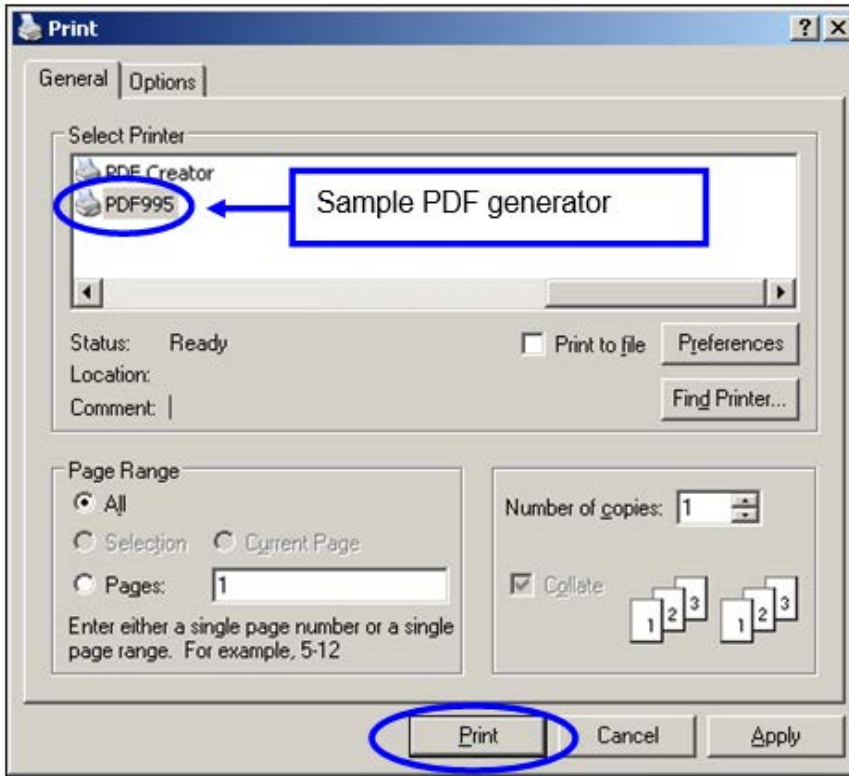

3. In the **Save in** field, click a location where you want to save the file, and then click **Save**. The report is generated and saved as a PDF file.

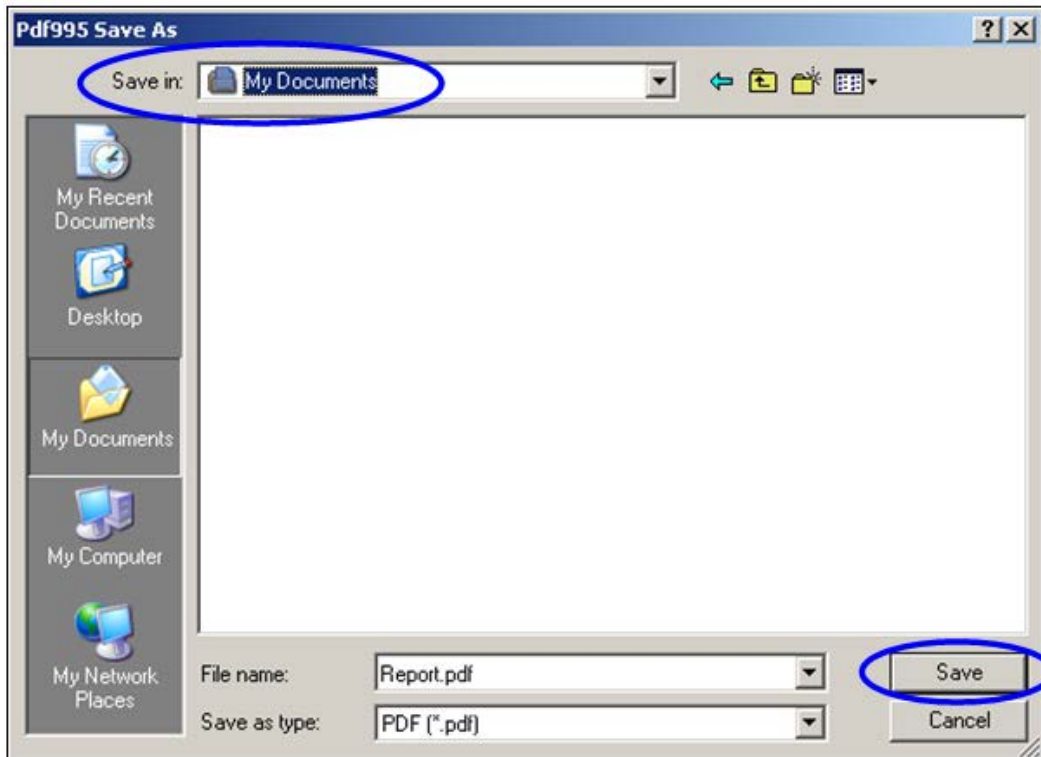

2. ISO Grading

Two ways to verify a barcode include:

- **Full** – Select this option to analyze a barcode in detail. This option displays the ISO parameters in detail.
- **Pass/Fail** – Select this option if you are not interested in the detailed analysis of the barcode. This option indicates whether the barcode meets your company’s minimum ISO grade requirements. In other words, this option indicates whether the barcode is good or bad.

A PASS and FAIL screen is displayed instead of the ISO parameters.



The minimum passing score for Pass / Fail is set up via the **Minimum passing** score parameter on the **Setup** tab. Changes to the grade can be restricted by unchecking the **Allow Change Setup Options** box under **Setup Operators** for each operator.

3. View Box

To better understand where a print quality problem is located, the software is designed to superimpose a color mark at the position of the problem. At the bottom right of the **Grading Tab** screen is a chart indicating what the different colors indicate.

There are 4 parameters that can be highlighted: Contrast, Modulation, Decodability and Defects. Click on the desired parameter.

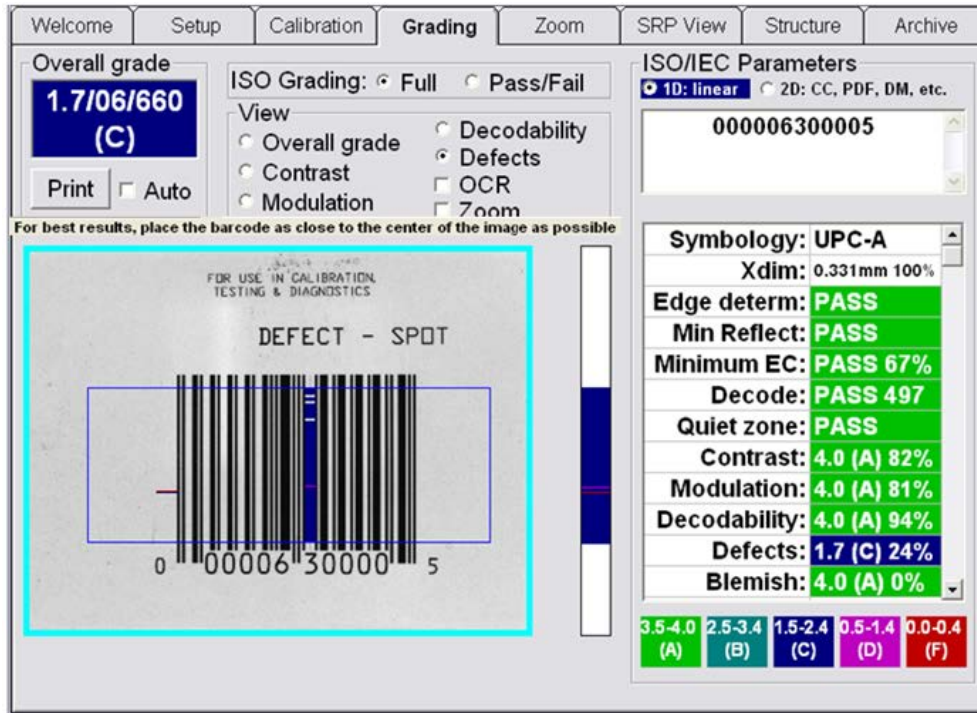

Position of problem superimposed on the barcode image.

Within the View Box there are two additional features that can be checked: OCR and Zoom (see next pages for additional information).

OCR (Human Readable Character Check)

This system is capable of verifying the Human Readable portion of a barcode. To check the human readable characters, right-click on the mouse and draw a green box around the human readable characters. If it matches the decoded barcode information, the software reports a “Match”.

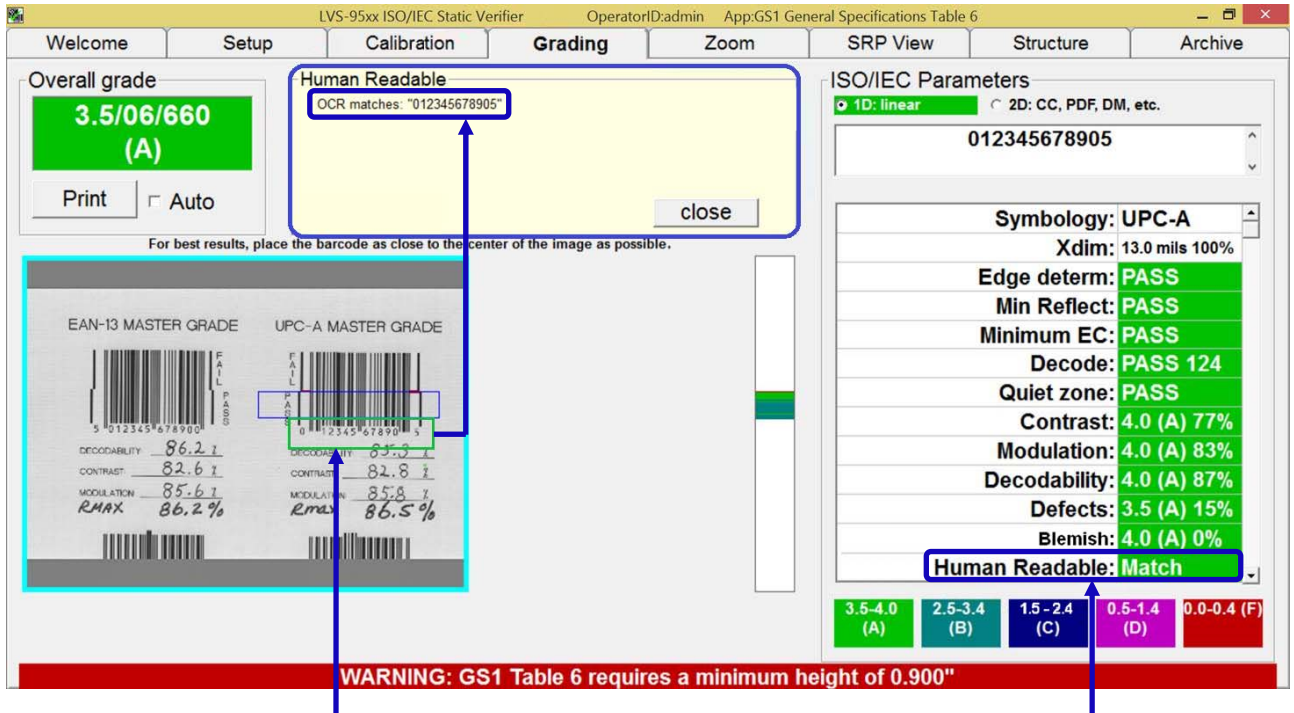

Draw a green box around the human readable characters. The green box is used to identify which OCR characters are to be validated.

The software reports a “match” if the human readable characters match the decoded barcode information.

The system supports OCR-A, OCR-B, Times New Roman, Arial, Courier, and most Sans-serif fonts. Upper case only. Special characters are not supported.

If the software cannot read the characters correctly, place the mouse cursor above the words “Human Readable”, circled in blue in the lower right of the image above, and single-click. A field with the heading “Human Readable” – also circled in blue in the image above – will appear above the captured image and to the left of the “Overall grade” area. The “Human Readable” field will show the characters that fall within the green box you have drawn on the captured image. Since the software was unable to read the characters, it would have no idea if the characters were alpha or numeric. Thus, the software shows the user both alpha and numeric data.

The human readable of a barcode can be checked most of the time provided the characters do not touch each other. The characters must also be large enough to read and in a straight line. The system is limited to reading up to 24 characters.

Zoom

The Zoom option allows you to view small labels. The screenshots below show labels with the zoom turned off and on.

Zoom Turned OFF:

For best results, place the barcode as close to the center of the image as possible

Overall grade																				
1.7/11/660 (C)																				
Print <input type="checkbox"/> Auto																				
ISO Grading: <input checked="" type="radio"/> Full <input type="radio"/> Pass/Fail		ISO/IEC Parameters																		
View		<input type="radio"/> 1D: linear <input checked="" type="radio"/> 2D: CC, PDF, DM, etc.																		
<input type="radio"/> Overall grade	<input type="radio"/> Decodability	<table border="1"> <tr> <td>Symbology:</td> <td>ECC-200</td> </tr> <tr> <td>Cell size:</td> <td>0.343mm</td> </tr> <tr> <td>Decode:</td> <td>PASS</td> </tr> <tr> <td>Contrast:</td> <td>4.0 (A) 89%</td> </tr> <tr> <td>Modulation:</td> <td>1.7 (C)</td> </tr> <tr> <td>Axial nonuniformity:</td> <td>4.0 (A) 0%</td> </tr> <tr> <td>Grid nonuniformity:</td> <td>4.0 (A) 22%</td> </tr> <tr> <td>Unused EC:</td> <td>4.0 (A) 100%</td> </tr> </table>			Symbology:	ECC-200	Cell size:	0.343mm	Decode:	PASS	Contrast:	4.0 (A) 89%	Modulation:	1.7 (C)	Axial nonuniformity:	4.0 (A) 0%	Grid nonuniformity:	4.0 (A) 22%	Unused EC:	4.0 (A) 100%
Symbology:	ECC-200																			
Cell size:	0.343mm																			
Decode:	PASS																			
Contrast:	4.0 (A) 89%																			
Modulation:	1.7 (C)																			
Axial nonuniformity:	4.0 (A) 0%																			
Grid nonuniformity:	4.0 (A) 22%																			
Unused EC:	4.0 (A) 100%																			
<input type="radio"/> Contrast	<input type="radio"/> Defects																			
<input checked="" type="radio"/> Modulation	<input type="checkbox"/> OCR																			
	<input type="checkbox"/> Zoom																			
<table border="1"> <tr> <td>3.5-4.0 (A)</td> <td>2.5-3.4 (B)</td> <td>1.5-2.4 (C)</td> <td>0.5-1.4 (D)</td> <td>0.0-0.4 (F)</td> </tr> </table>					3.5-4.0 (A)	2.5-3.4 (B)	1.5-2.4 (C)	0.5-1.4 (D)	0.0-0.4 (F)											
3.5-4.0 (A)	2.5-3.4 (B)	1.5-2.4 (C)	0.5-1.4 (D)	0.0-0.4 (F)																

Zoom Turned ON:

For best results, place the barcode as close to the center of the image as possible

Overall grade																				
1.7/11/660 (C)																				
Print <input type="checkbox"/> Auto																				
ISO Grading: <input checked="" type="radio"/> Full <input type="radio"/> Pass/Fail		ISO/IEC Parameters																		
View		<input type="radio"/> 1D: linear <input checked="" type="radio"/> 2D: CC, PDF, DM, etc.																		
<input type="radio"/> Overall grade	<input type="radio"/> Decodability	<table border="1"> <tr> <td>Symbology:</td> <td>ECC-200</td> </tr> <tr> <td>Cell size:</td> <td>0.343mm</td> </tr> <tr> <td>Decode:</td> <td>PASS</td> </tr> <tr> <td>Contrast:</td> <td>4.0 (A) 89%</td> </tr> <tr> <td>Modulation:</td> <td>1.7 (C)</td> </tr> <tr> <td>Axial nonuniformity:</td> <td>4.0 (A) 0%</td> </tr> <tr> <td>Grid nonuniformity:</td> <td>4.0 (A) 22%</td> </tr> <tr> <td>Unused EC:</td> <td>4.0 (A) 100%</td> </tr> </table>			Symbology:	ECC-200	Cell size:	0.343mm	Decode:	PASS	Contrast:	4.0 (A) 89%	Modulation:	1.7 (C)	Axial nonuniformity:	4.0 (A) 0%	Grid nonuniformity:	4.0 (A) 22%	Unused EC:	4.0 (A) 100%
Symbology:	ECC-200																			
Cell size:	0.343mm																			
Decode:	PASS																			
Contrast:	4.0 (A) 89%																			
Modulation:	1.7 (C)																			
Axial nonuniformity:	4.0 (A) 0%																			
Grid nonuniformity:	4.0 (A) 22%																			
Unused EC:	4.0 (A) 100%																			
<input type="radio"/> Contrast	<input type="radio"/> Defects																			
<input checked="" type="radio"/> Modulation	<input type="checkbox"/> OCR																			
	<input checked="" type="checkbox"/> Zoom																			
<table border="1"> <tr> <td>3.5-4.0 (A)</td> <td>2.5-3.4 (B)</td> <td>1.5-2.4 (C)</td> <td>0.5-1.4 (D)</td> <td>0.0-0.4 (F)</td> </tr> </table>					3.5-4.0 (A)	2.5-3.4 (B)	1.5-2.4 (C)	0.5-1.4 (D)	0.0-0.4 (F)											
3.5-4.0 (A)	2.5-3.4 (B)	1.5-2.4 (C)	0.5-1.4 (D)	0.0-0.4 (F)																

4. Grade Bar Graph

To the right of the barcode image is a graph representing the ISO grade for every scan line. It is called the Grade Bar Graph and displays whatever ISO parameter is checked in the View section. For 1D symbologies, there are 4 parameters to choose from: Contrast, Modulation, Decodability, and Defects. This helps you to identify what parts of the barcode have quality issues. The color refers to the grade in terms of the legend on the bottom right of the screen.

The Grade Bar Graph displays line-for-line grade information for every line of the bar height. If there is no color code indicated for a specific line, then the line was not decodable. This would be counted as a blemish.

The screenshot shows the software interface with the following elements:

- Overall grade:** 4.0/06/660 (A)
- ISO Grading:** Full (selected), Pass/Fail
- View:** Overall grade (selected), Contrast, Modulation, Decodability, Defects, OCR, Zoom
- ISO/IEC Parameters:** 1D: linear (selected), 2D: CC, PDF, DM, etc.
- Barcode:** 6 14141 99999 6
- Grade bar graph:** A vertical bar on the right of the barcode image, with a blue arrow pointing to it from the label "Grade bar graph".
- Parameters table:**

Symbology:	UPC-A
Xdim:	12.8 mils 98%
Edge determ:	PASS
Min Reflect:	PASS
Minimum EC:	PASS 67%
Decode:	PASS 314
Quiet zone:	PASS
Contrast:	4.0 (A) 83%
Modulation:	4.0 (A) 81%
Decodability:	4.0 (A) 72%
Defects:	4.0 (A) 6%
Blemish:	4.0 (A) 0%
- Grade Legend:**

3.5-4.0 (A)	2.5-3.4 (B)	1.5-2.4 (C)	0.5-1.4 (D)	0.0-0.4 (F)
-------------	-------------	-------------	-------------	-------------

Bar Height Measurement

The method of determining the height of a barcode is based on the number of lines decoded within the height. The software takes the first decoded line and decodes all lines until the end of the barcode; and, because we know the size of one pixel, the height of the barcode can be calculated. If some lines either at the top or bottom of the sector could not be decoded, the height calculation will be incorrect.

5. ISO/IEC Parameters Section

This section lists all of the measured parameters individually. These parameters are used to determine why a barcode has a certain grade. There are numerous parameters listed, depending on the symbology. Use the scroll bar to view the entire list of parameters.

At the top of this section is an information box that displays the decoded data. This data does not contain any stop, start, or control (non-printable) characters. Check digits may or may not be displayed depending on the symbology. For example, Code 128 mandates that they not be transmitted. The software always displays the check digit for symbologies that make the transmission of check digits optional. To see special characters or check digits, refer to the **Structure** tab chapter covered later in this manual.

Below the encoded barcode data, but still within the information box, is a Product Identification name for all UPC-A, UPC-E, EAN-8 and EAN-13 barcodes that are contained within the Product Identification data file (see **Setup Tab | System Settings | Product Identification (Lookup) File** for more information).

For best results, place the barcode as close to the center of the image as possible

ISO/IEC Parameters

1D: linear 2D: CC, PDF, DM, etc.

614141999996

Symbology: UPC-A

Xdim: 12.8 mils 98%

Edge determ: PASS

Min Reflect: PASS

Minimum EC: PASS 67%

Decode: PASS 314

Quiet zone: PASS

Contrast: 4.0 (A) 83%

Modulation: 4.0 (A) 81%

Decodability: 4.0 (A) 72%

Defects: 4.0 (A) 6%

Blemish: 4.0 (A) 0%

3.5-4.0 (A) 2.5-3.4 (B) 1.5-2.4 (C) 0.5-1.4 (D) 0.0-0.4 (F)

6. Blemish (Non-ISO Parameter)

A blemish error is defined as any mark or artifact that destroys the decode on any part of the barcode symbol.

Within the *ISO/IEC parameters* box, there is a *Blemish* measurement. Although a blemish error is not considered to be a part of the ISO standards, it is an extremely useful tool when troubleshooting printing problems. The Blemish parameter is not figured into the Overall grade unless the **Allow non-ISO blemish to affect grade** feature is checked on the **Setup Tab** screen.

A Blemish is also a measurement of bar height consistency. Be sure to position the blue box so that it represents the actual height of the barcode image.

A blemish can only be measured where there are decodable lines above and below the offending mark.

Screenshot with the **Allow non-ISO blemish to affect grade** feature checked:

The screenshot displays the software interface with the following details:

- Overall grade:** 3.2/10/660 (B)
- ISO Grading:** Full (selected), Pass/Fail
- View:** Overall grade, Contrast, Modulation, Decodability, Defects, OCR, Zoom
- ISO/IEC Parameters:** 1D: linear (selected), 2D: CC, PDF, DM, etc.
- Barcode:** 0 412785 127832
- Symbology:** UPC-A
- Xdim:** 0.368mm 111%
- Edge determ:** PASS
- Min Reflect:** PASS
- Minimum EC:** PASS 67%
- Decode:** PASS 242
- Quiet zone:** PASS
- Contrast:** 4.0 (A) 80%
- Modulation:** 4.0 (A) 84%
- Decodability:** 4.0 (A) 71%
- Defects:** 4.0 (A) 5%
- Blemish:** 3.2 (B) 19%

WARNING: Non ISO blemish errors reduced the overall grade by 19%

Warning message that appears when the **Allow non-ISO blemish to affect grade** feature is checked.

Screenshot with the **Allow non-ISO blemish to affect grade** feature NOT checked:

The screenshot shows the software interface with the following details:

- Overall grade:** 4.0/10/660 (A)
- ISO Grading:** Full (selected), Pass/Fail
- View:** Overall grade, Decodability, Defects, Contrast, OCR, Modulation, Zoom
- ISO/IEC Parameters:** 1D: linear (selected), 2D: CC, PDF, DM, etc.
- Barcode:** 412785127832
- Symbology:** UPC-A
- Edge determ:** PASS
- Min Reflect:** PASS
- Minimum EC:** PASS 64%
- Decode:** PASS 249
- Quiet zone:** PASS
- Contrast:** 4.0 (A) 79%
- Modulation:** 4.0 (A) 81%
- Decodability:** 4.0 (A) 70%
- Defects:** 4.0 (A) 8%
- Blemish:** 3.2 (B) 19%

A blue arrow labeled "Blemish" points to a dark spot on the barcode. A red banner at the bottom of the interface reads: "WARNING: Non ISO blemish errors of 19% not included in the overall grade". A blue arrow points from this banner to the text: "Warning message that appears when the Allow non-ISO blemish to affect grade feature is NOT checked."

Other Grading Screen Tools

Opacity

A barcode must be verified under the same conditions as its final configuration when possible. If the barcode is printed on a media having low opacity (meaning the substrate is transparent or translucent), perform the verification with the symbol on a dark surface (if the final configuration will be dark) or a light surface (if the final configuration will be light). Attempt to match the final configuration as closely as possible.

- **For LVS-9500 systems:** Place a sheet of paper the color of the final configuration (e.g. white, black, etc.) on the viewing stage then place barcode on top of the paper. This will simulate the final configuration and allow the LVS-95XX software to produce verification results that will closely match the expected final reading conditions.
- **For LVS-9505 or 9510 (desktop) systems:** Place the barcode on the viewing window then place a sheet of paper the color of the final configuration (e.g. white, black, etc.) on top of the barcode This will simulate the final configuration and allow the LVS-95XX software to produce verification results that will closely match the expected final reading conditions.
- **For LVS-9570 (hand-held) systems:** Place a sheet of paper the color of the final configuration (e.g. white, black, etc.) on a flat surface then place barcode on top of the paper. This will simulate the final configuration and allow the LVS-95XX software to produce verification results that will closely match the expected final reading conditions.

Color Codes

The system reports ISO/IEC grades by a color code. The bottom right of the **Grading Tab** screen shows a legend of these color codes which correspond to the ISO/ANSI grading system. This color code is also used on the **SRP View Tab** screen.

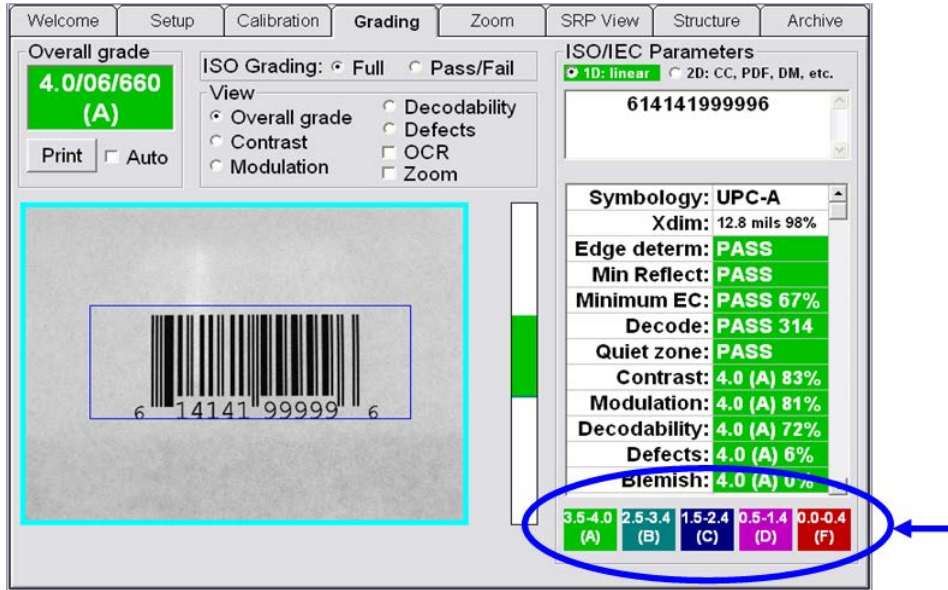

Height and Width Measurement

Any time the mouse is held down to draw a sector, the bottom of the screen displays the actual measurement of the sector being drawn. This helps to measure the height and width of the actual barcode. This measurement is not a measurement of the barcode; it is a measurement of the box being drawn.



Barcode Too Wide for Field of View (Stitching Feature)

The Stitching feature is used to grade barcode labels that are too wide for the field of view. Follow the instructions below to use the Stitching feature.

The entire process of stitching a label requires the user to correctly align the images being stitched. Failure to correctly align the labels results in the barcode being graded poorly. When in doubt, perform the stitching process again. The stitching feature does not work for all barcodes

1. Activate the Stitching feature by pressing the [Ctrl + S] keyboard buttons at the same time; the screen changes as shown in the screenshot below.

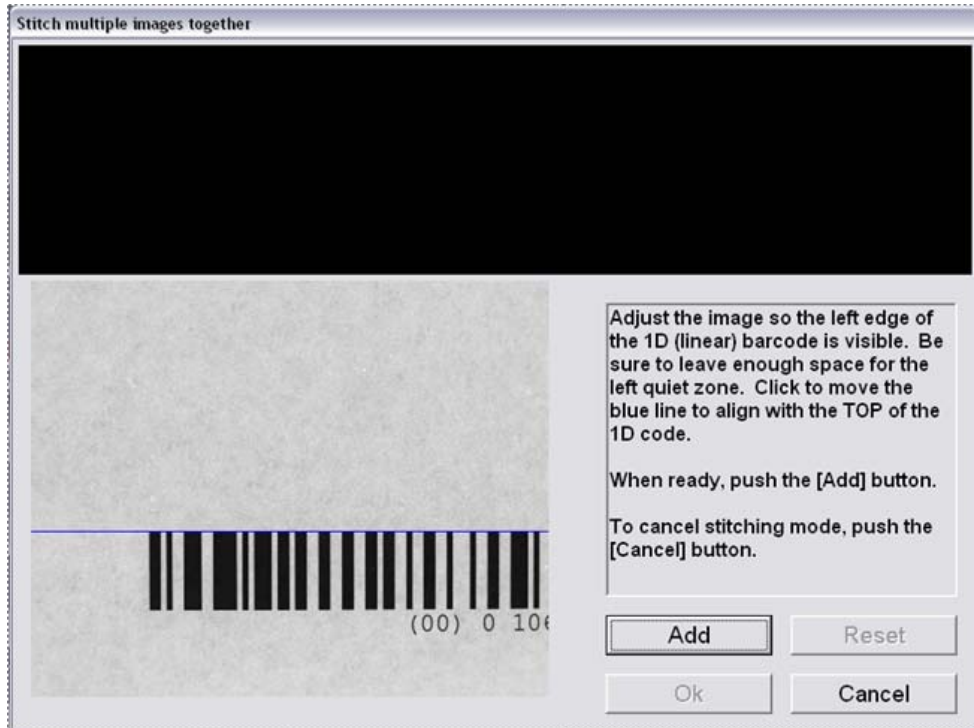

- Adjust the image so the left edge of the linear barcode is visible and leave enough space for the left quiet zone.

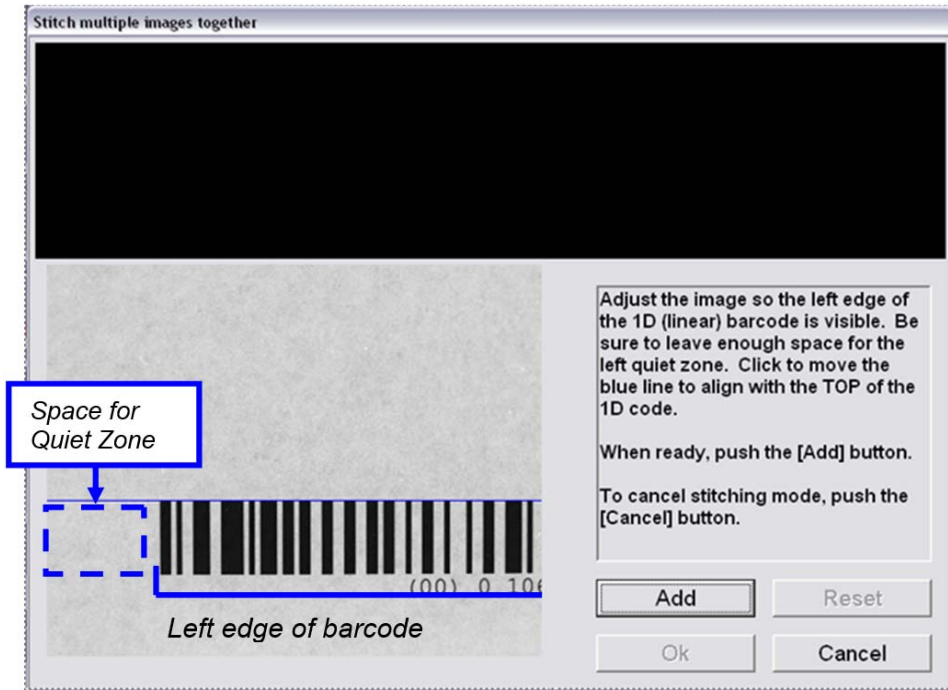

- Line up the top of the barcode to the blue line; this can be done by positioning the barcode itself or by clicking on the blue line with your mouse.
- Press the “Add” button; the resulting image appears in the top, left corner of the screen. You will also notice a blue line and a dotted red line; these lines are tools used for barcode alignment purposes. The goal is to keep the barcode image perfectly straight. Always keep the bars perpendicular to the blue line and keep the top of the barcode aligned to the same blue line.

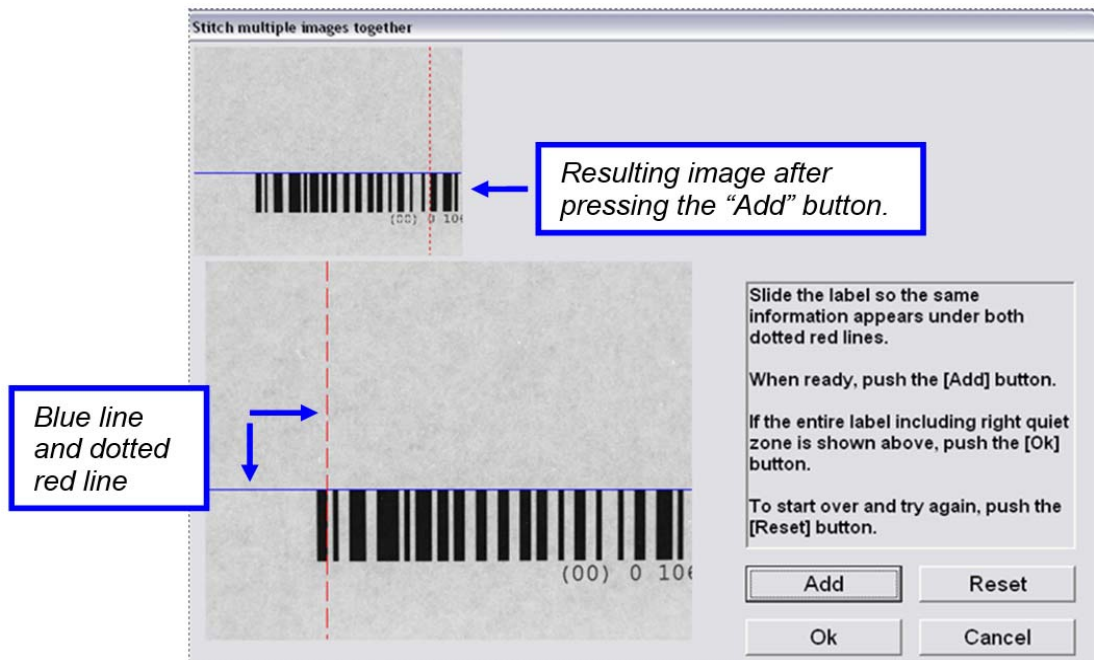

- The onscreen instructions prompt you to slide the label so that the same information appears under both dotted red lines; this is where the label is to be spliced.

Notice in the screenshot below that the “0” (which is part of the human readable characters) is positioned over the red line on the top image as well as on the bottom image. Also notice that the top of the barcode is still perfectly aligned to the blue line. When done, click the “Add” button.

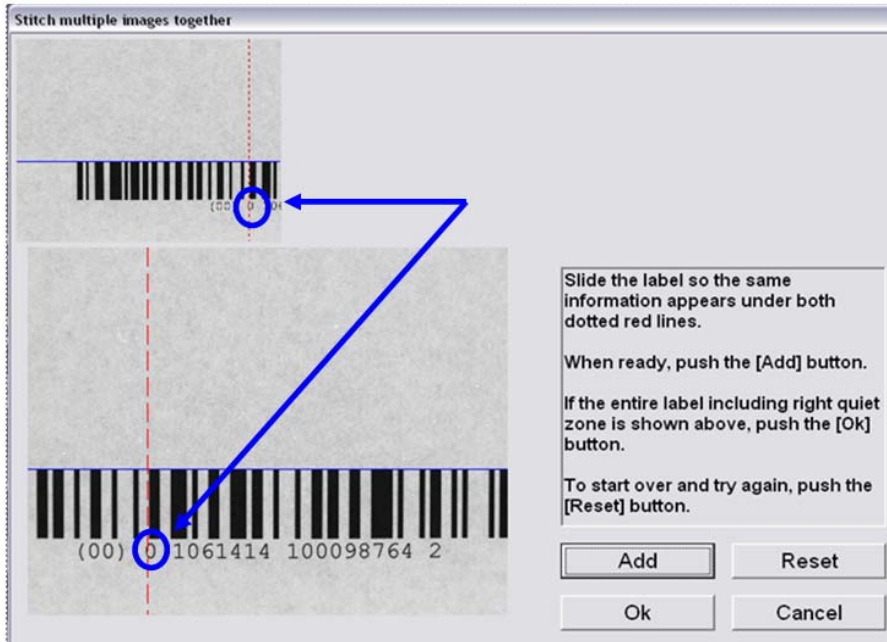

- The stitched image appears at the top of the screen. The red line shifts over to a new position and you are now prompted to move the label over to its new stitching position.

The screenshot below shows that the new position is located after the number “2” human readable character.

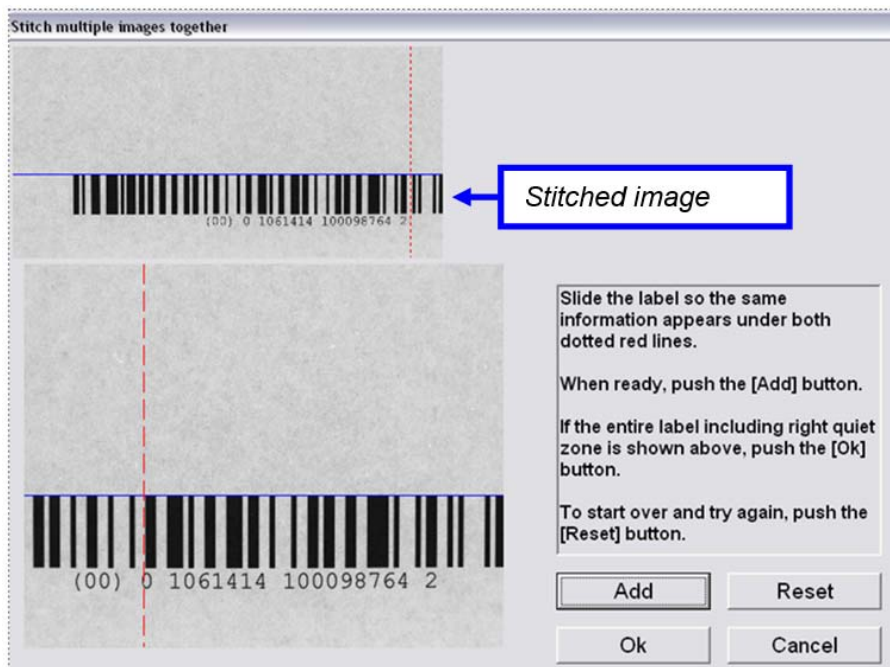

7. In the screenshot below, the label has been moved to its proper stitching position. Notice that the bottom image is aligned to the red line in the same position as indicated in the stitched image. Also notice that the bottom image barcode continues to be aligned perfectly to the blue line. When done, press the "Add" button.

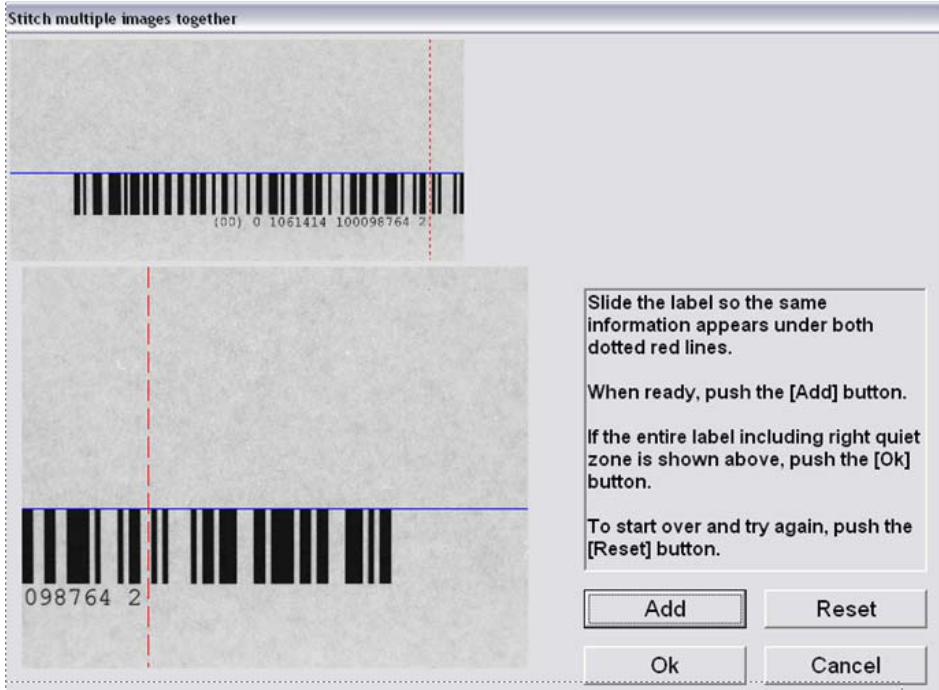

8. In the screenshot below, the right end of the barcode appears along with the appropriate space for a quiet zone, indicating that no additional stitching is required. Press the "Ok" button.



9. The Grading screen appears and the stitched image is graded automatically.

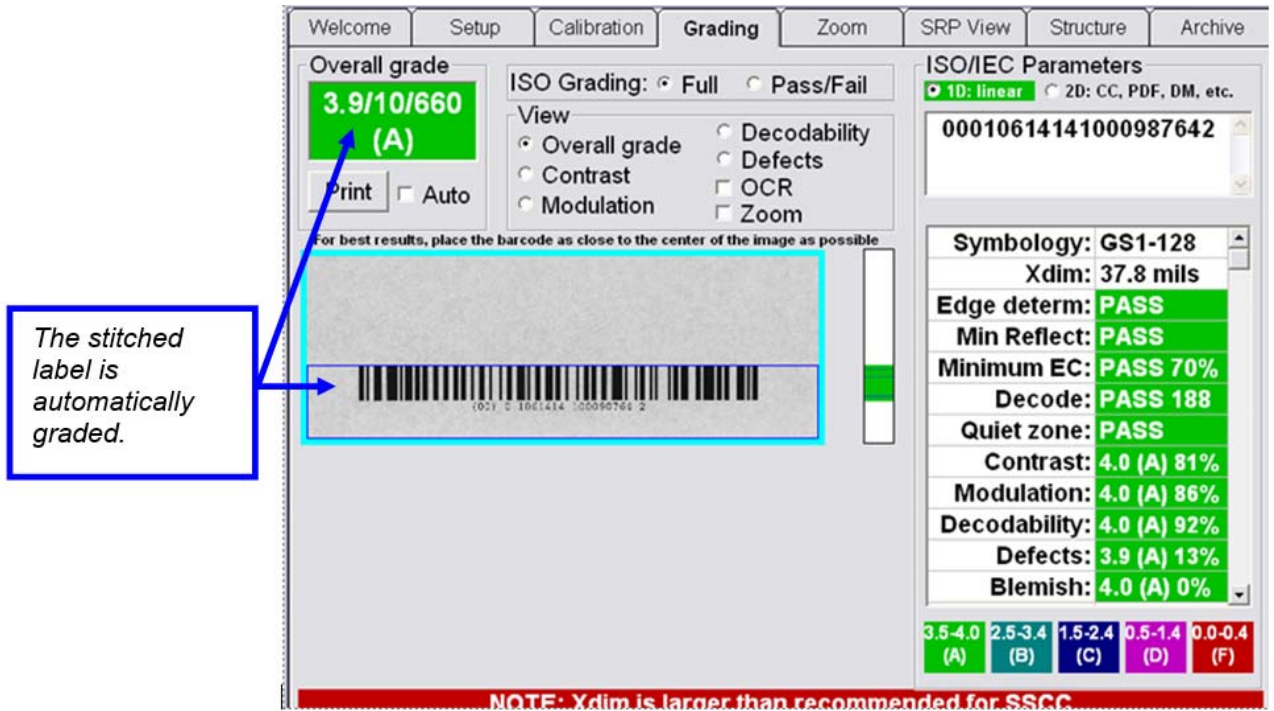

10. When the Stitching feature is complete, the LVS-95XX software automatically turns off the camera; however, the camera must be turned back on. To turn on the camera, click the “Setup” tab and click “On” within the “Camera” section.



Section 2: Matrix Codes

The LVS-95XX system verifies the following matrix codes:

- Data Matrix ECC 200 (both square and rectangular symbols)
- QR Code
- Micro QR Code
- Aztec Code
- Chinese Sensible (Han Xin) Code
- MaxiCode

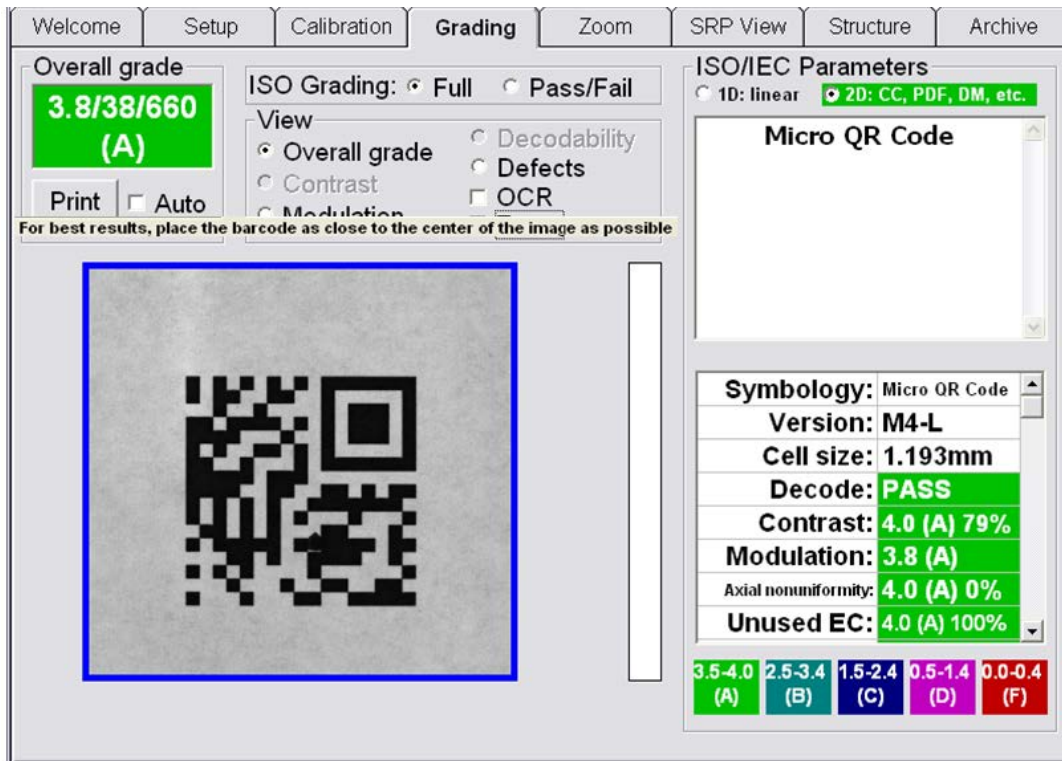

Verify a Matrix Code

Place the code into the field of view and draw a blue square around the image by clicking the mouse and holding it down (see above image). There should not be any other marks or characters within this quiet zone. The code can be placed at any desired angle.

View Section

At the top center of the **Grading Tab** screen is the View box. There are 5 features available for Data Matrix: Overall Grade, Defects, Zoom, OCR, and Modulation.

1. Overall Grade

The system is defaulted to show the Overall Grade.

2. Defects

This feature indicates cells that are the wrong side of the global threshold (i.e. a cell intended to be white is interpreted as black; a cell intended to be black is interpreted as white). The software also detects cells that

are not in the correct spot or have a blemish. When this occurs, error correction is used and causes the software to highlight the cells in red where error correction was applied.

3. Zoom

Data Codes are often very small. The Zoom feature is used to magnify the image for easier visual inspection.

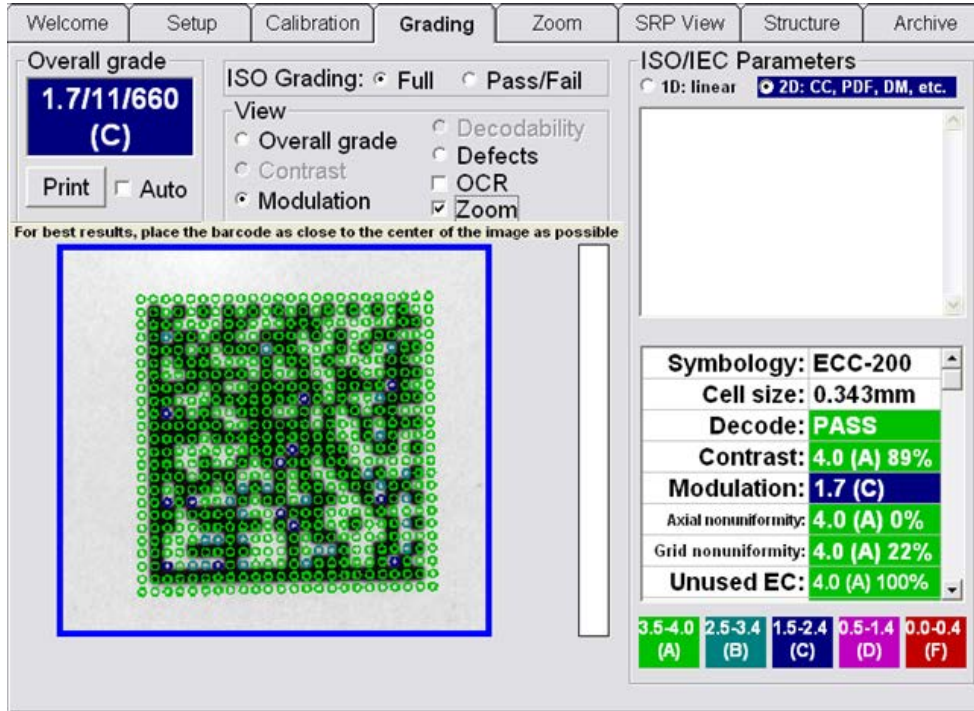

If the Zoom feature, along with either the Modulation, Defects, or OCR feature, are checked and a Verification Report is printed, the thumbnail view on the report shows the results in color according to the legend at the bottom of the screen.

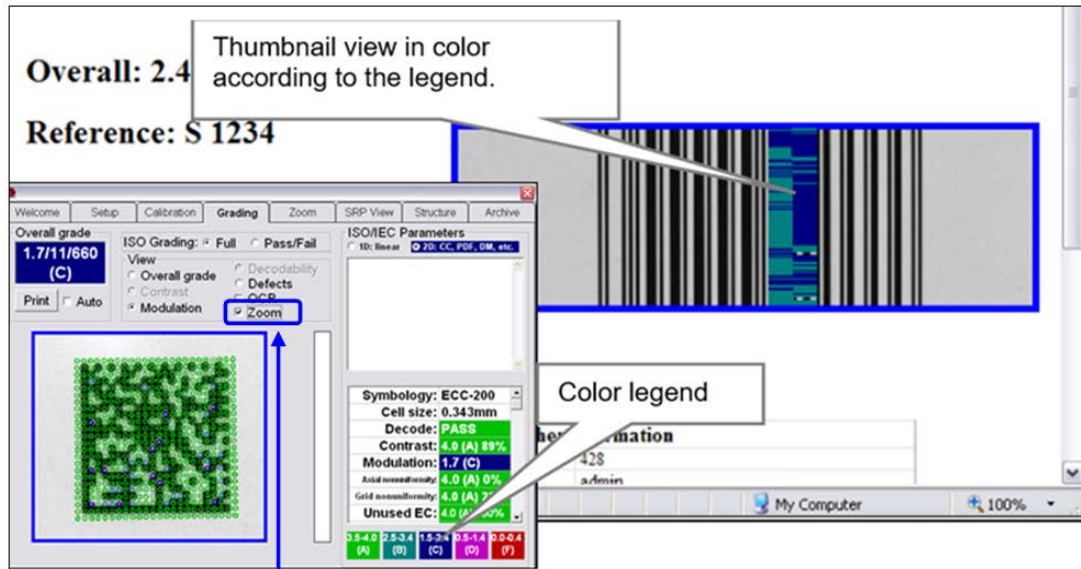

The Zoom feature magnifies the image for easier visual inspection.

4. OCR

To check the human readable characters, right-click on the mouse and draw a box around the human readable characters; the box appears in green. The software reports a “match” if it matches the decoded barcode information.

The system supports OCR-A, OCR-B, Times New Roman, Arial, Courier, and most San-serif fonts. Upper case only. Special characters are not supported.

The human readable of a barcode label can be checked most of the time provided the characters do not touch each other. The characters must also be large enough to read and in a straight line. The system is limited to reading up to 24 characters.

5. Modulation

To view a modulation error, click the **Modulation** option. It is recommended to activate the Zoom button along with the Modulation button so that the image is large enough to view the details.

When viewing Modulation errors, the software may use a “yellow” mark. A yellow mark indicates that the Modulation measurement for that cell was less than 20 percent. In fact, what should have been black or white was actually measured to be the opposite of what it should have been.

Multi-Rotation Codes

DataMatrix

If **Multi-Rotation Codes** is selected as the preferred Application standard on the **Setup Tab** screen, you are prompted to rotate the code after drawing the box. Ensure that the box is large enough to accommodate the symbol at all rotation angles. An overlay will assist you to place the symbol at the desired angle; it consists of a solid “L” and a dotted “L.”

- The solid portion represents the “L” finder pattern
- The dotted portion represents the opposite clock tracks

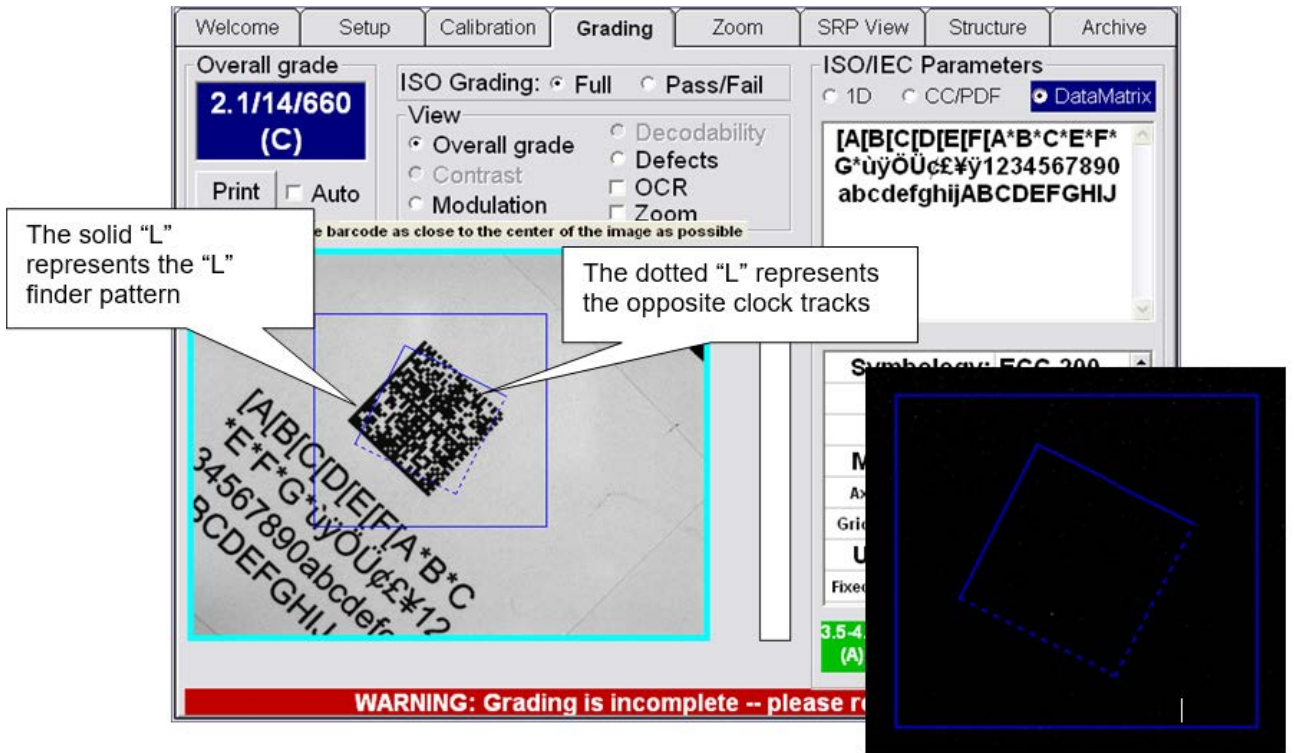

IMPORTANT: When using a DataMatrix code, the “SRP View” tab name changes to “2D Analysis;” this is because the “SRP View” tab is for analysis of 1D codes only.

The “2D Analysis” tab displays the “LVS-95XX 2D Analysis Report.”

QR Code

For correct placement for QR Code, position the finder patterns on the blue dots.

Overall grade
0.0/25/660 (F)

ISO Grading: Full Pass/Fail

View
 Overall grade Decodability
 Contrast Defects
 Modulation OCR

ISO/IEC Parameters
 1D: linear 2D: CC, PDF, DM, etc.

なおこのデモはrefererを返さないブラウザでは正しく見れませんので了承ください。

Symbology: QR Code
 Version: 5-M
 Cell size: 0.788mm
 Decode: **PASS**
 Contrast: **3.9 (A) 76%**
 Modulation: **2.6 (B)**
 Axial nonuniformity: **4.0 (A) 0%**
 Unused EC: **4.0 (A) 100%**

3.5-4.0 (A) 2.5-3.4 (B) 1.5-2.4 (C) 0.5-1.4 (D) 0.0-0.4 (F)

WARNING: The angle 79 is not valid for Multi-rotation QR Code

After grading all five rotations, a report appears showing the average grade of all rotations.

To view the individual details for each angle of rotation, click the **Archive** tab | **Recent reports (last 30 days)**.

Reference: Test99

Operator signature _____

Second signature _____

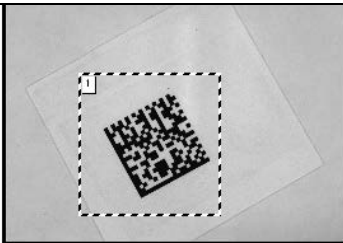

Overall grade	
Decoded text	The LVS-7000€, system isu
Angle 45	3.9/23/660 (A)
Angle 117	3.8/23/660 (A)
Angle 189	4.0/23/660 (A)
Angle 261	4.0/23/660 (A)
Angle 333	4.0/23/660 (A)

Other information	
ReportID	1749
Operator	admin
Application standard	Multi-rotation Data Matrix

Section 3: Two-Dimensional Multi-Row Codes

The family includes:

- PDF 417
- Micro PDF 417
- GS1 Databar CC-A
- GS1 Databar CC-B
- GS1 Databar CC-C

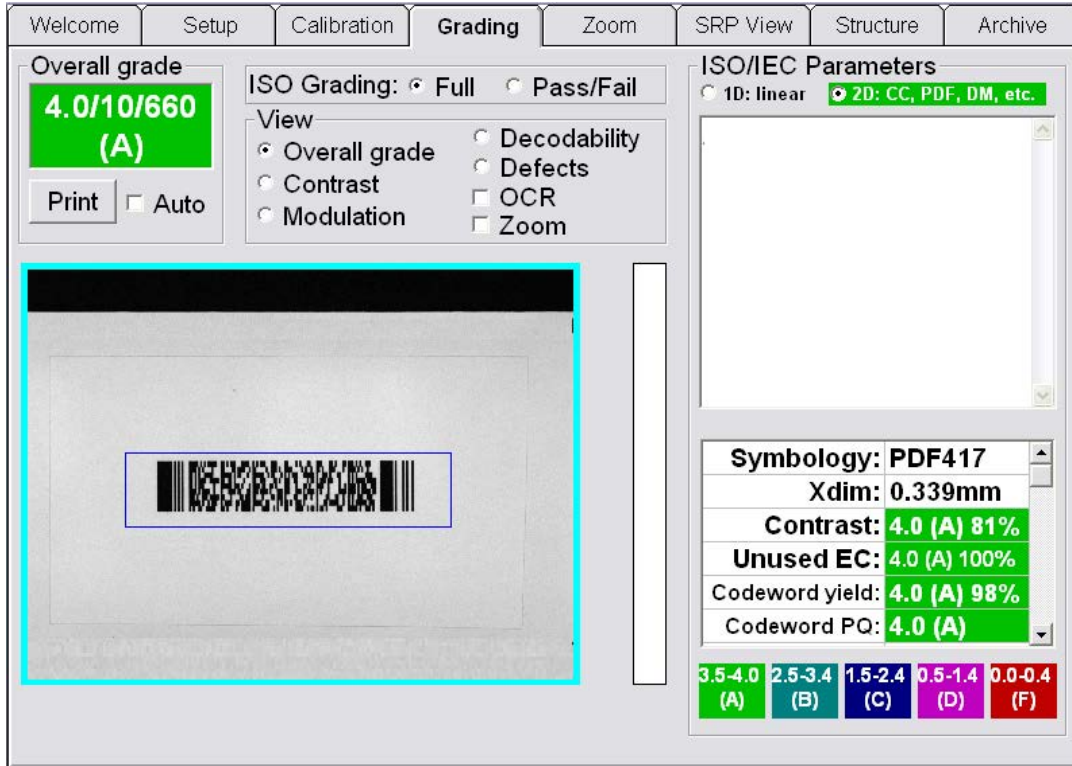

Verify a PDF 417 or Micro PDF 417 Code

Place the symbol into the field of view squarely and with the right and left alignment bars positioned straight up and down (see above image). The symbol can have no more than a 4-degree tilt. While placing the cursor on the video image, hold down the mouse and draw a box around the barcode image; the box appears as a blue box.

The system now reports its grade. There may be a few seconds delay in displaying the verification results depending on how much data is encoded within the symbol.

PDF417 Parameters

There are a total of eight reported parameters. Use the scroll bar to view all of these parameters.

GS1 Databar Composite Verification

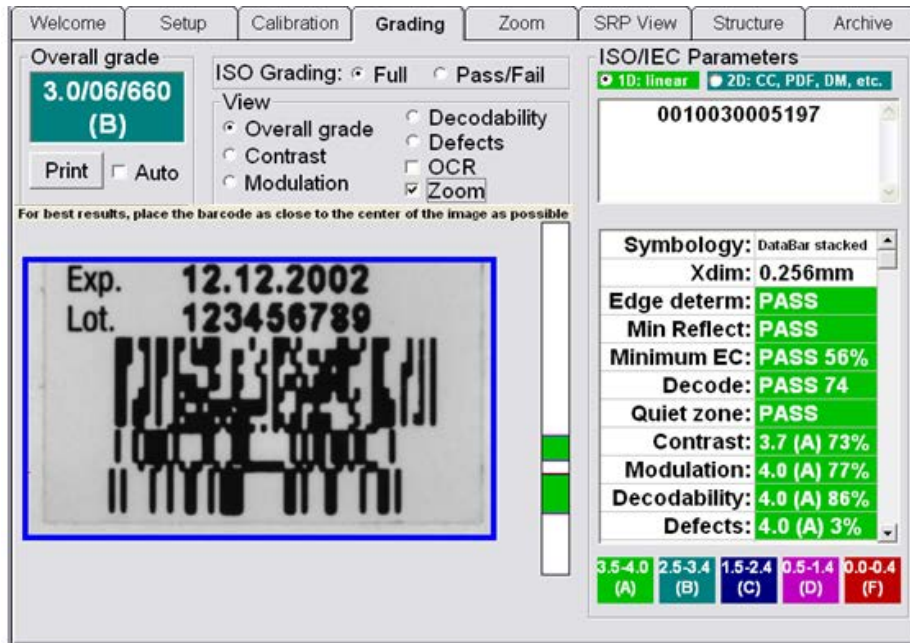

GS1 Databar Composite Verification – 1D

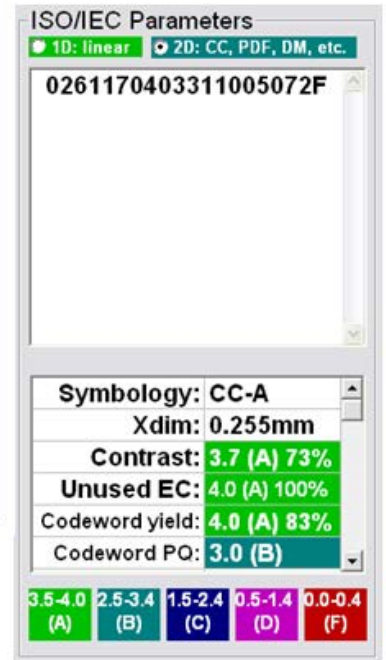

GS1 Databar Composite Verification – 2D

The LVS-95XX system supports all GS1 Databar and GS1 Databar Composite codes:

- GS1 Databar Omnidirectional
- GS1 Databar Truncated
- GS1 Databar Stacked
- GS1 Databar Stacked Omnidirectional
- GS1 Databar Limited
- GS1 Databar Expanded
- GS1 Databar Expanded Stacked
- GS1 Databar – CCA, CCB, CCC

Verify a Composite Code

A Composite code contains two basic sections: The 1D and 2D parts. Hold down the mouse button and draw a blue box around the barcode image. Since there are reduced quiet zones for GS1 Databar, make the box tight. Also, the barcode image must be square to the field of view. The symbol can have no more than a 4-degree tilt.

IMPORTANT: Always position the barcode as close to the center of the field of view as possible.

On the upper right side of the **Grading Tab** screen there are two boxes marked 1D and 2D. Choose which section of the code you wish to view.

- The 1D section contains the linear or 1D verification data.
- The 2D section contains the composite portion of the code.

The box at the top of the screen shows the encoded data.

Note: Blemish percentage has been turned off for all GS1 Databar Composite codes.

Note: All Linear codes that require a composite code component require a linkage flag indicating the requirement, with the exception of EAN-13, UPC-A and UPC-E. The GS1 Databar family of Linear codes have a linkage flag as part of the encodation method. GS1-128 codes have a linkage flag based on a superfluous code set switch immediately prior to the eternal, non-transmittable check digit.

Zoom Tab

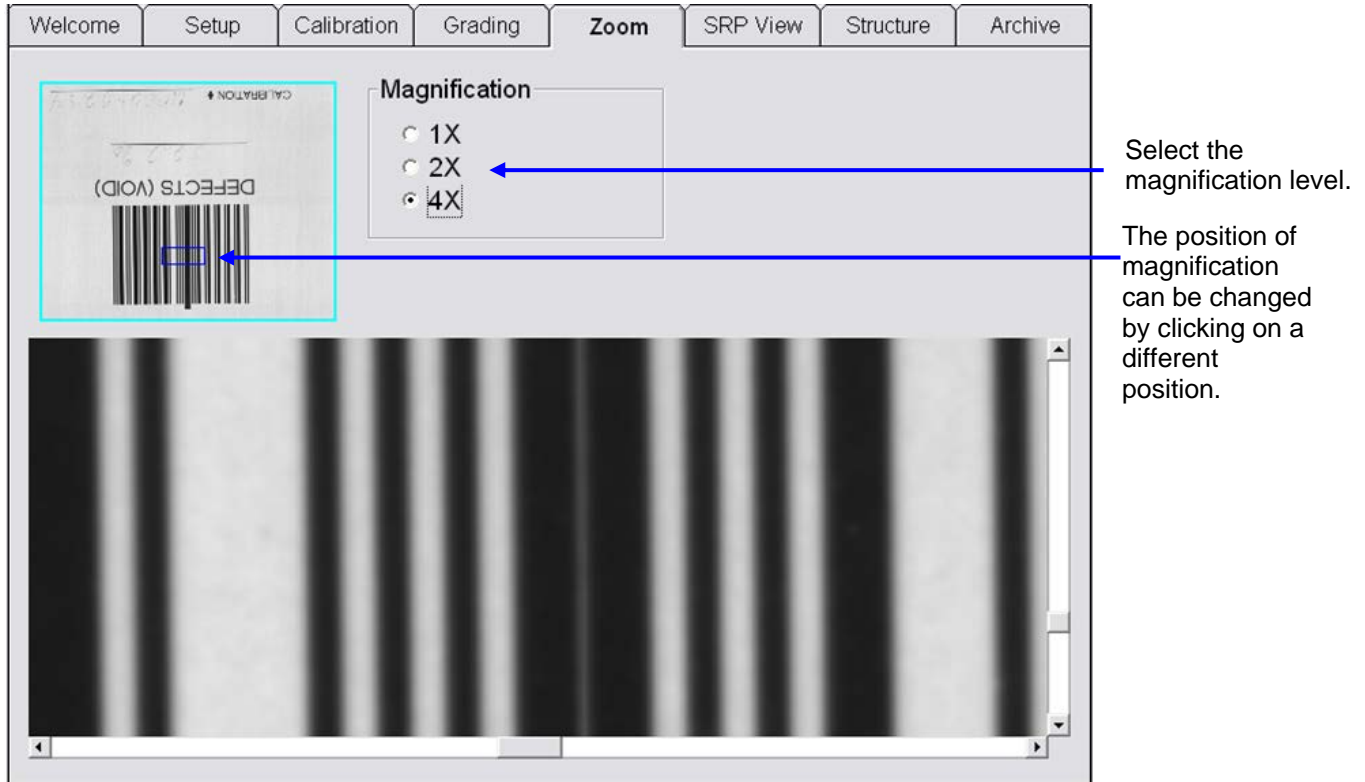

To further evaluate the quality of barcode symbols, the **Zoom Tab** screen allows you to magnify the barcode image up to four times.

The position of magnification can be changed by clicking to a different position on the image box located on the upper left corner of the screen.

There are scroll bars located at the side and at the bottom of the screen that allow the user the ability to change its horizontal and vertical position.

SRP View Tab

To further evaluate a barcode error, you may wish to view the Scan Reflectance Profile (SRP). Select the **SRP View** tab. The SRP is displayed for the selected area as determined by the blue line overlaying the image of the barcode on the top left side of the screen.

You can look at the SRP for any part of the barcode by simply clicking on another part of the image in the box located on the upper left corner of the **SRP View Tab** screen.

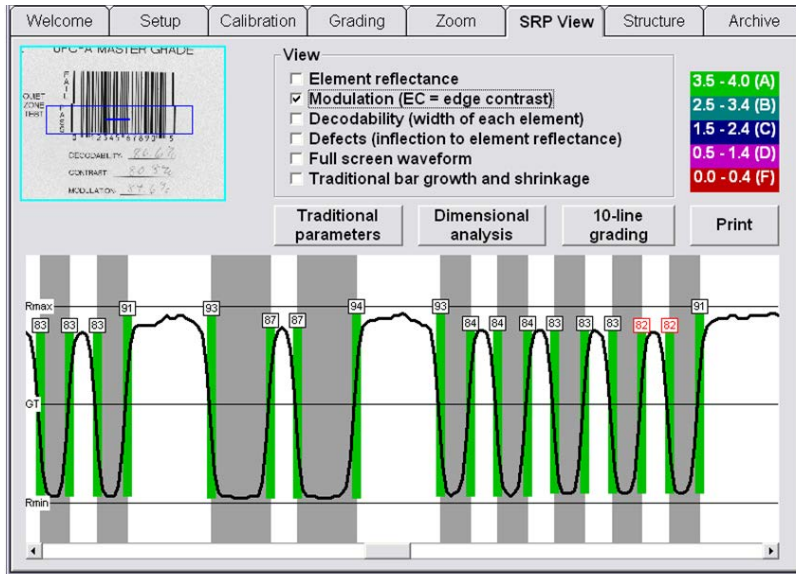

SRP View Screen showing a defect error

When the “Postal (Intelligent Mail, PostNet, Japan Post)” Application Standard is selected, the “SRP View” tab name changes to “Bar details” to provide an analysis report of the postal barcode.

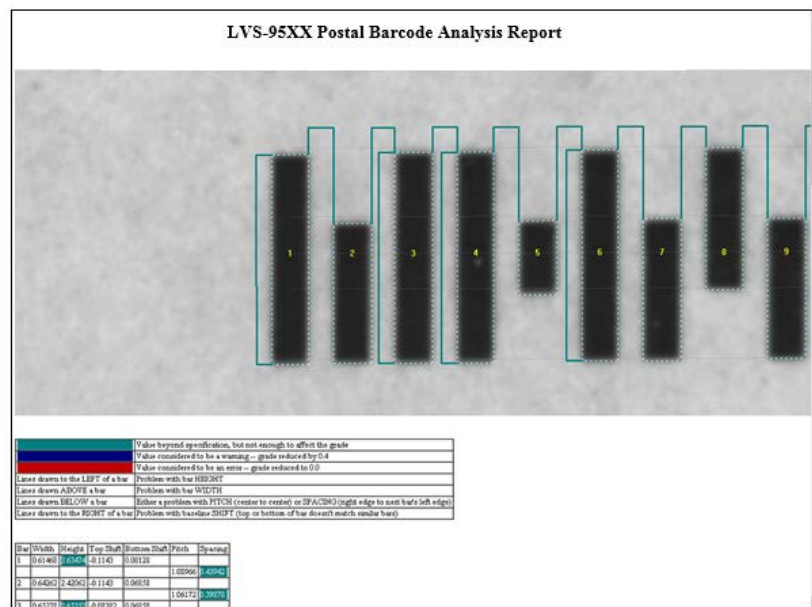

When using a DataMatrix code, the “SRP View” tab name changes to “2D Analysis;” this is because the “SRP View” tab is for analysis of 1D codes only. The “2D Analysis” tab displays the “LVS-95XX 2D Analysis Report.”

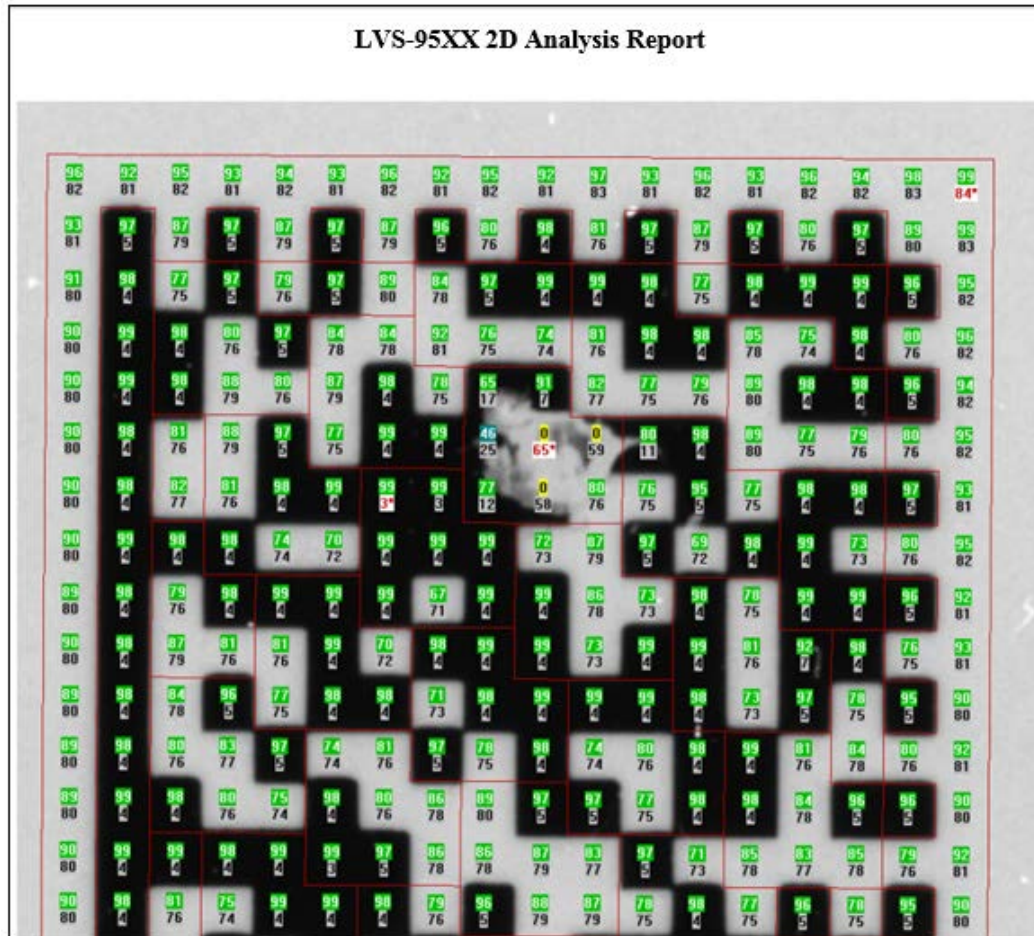

View Section

Under the View section, you can select what kind of error will be super-imposed onto the SRP graph. Rmax and Rmin numbers are also displayed.

Options include:

- Element reflectance
- Modulation (EC = Edge Contrast)
 - If “Modulation” is selected, the modulation for each dark/white transition is displayed. The lowest modulation for that scan line is displayed in red.
- Decodability (width of each element)
- Defects (inflection to element reflectance)
- Full screen waveform
- Traditional bar growth and shrinkage

The background of the **SRP View Tab** screen represents the bars and spaces of the actual barcode symbol. The global threshold is also displayed.

The Up and Down arrows on the keyboard allow you to inspect every scan line. Each scan line is approximately 0.05 mm (.002”) apart.

Full Screen Waveform

The Full Screen Waveform feature allows you to view the entire Scan Reflectance Profile at one time.

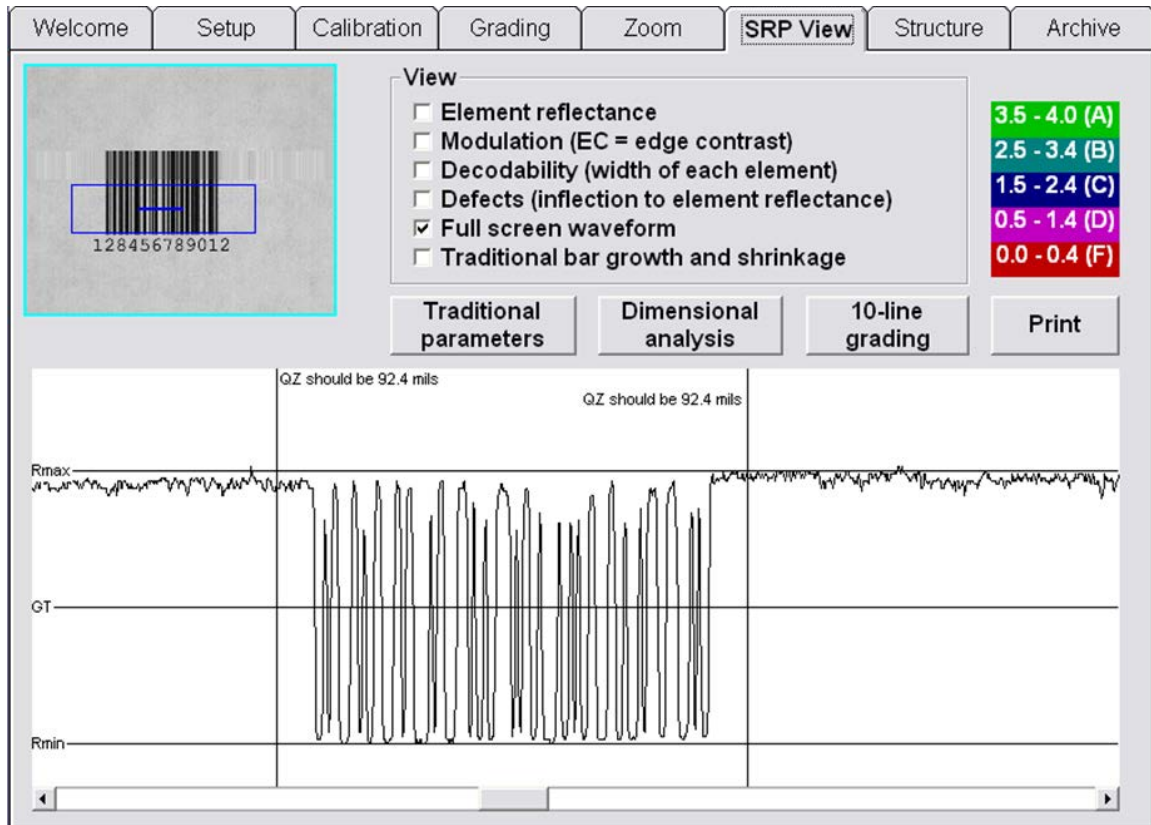

Note: If a quiet zone failure occurs, click the viewing box to locate the failure. The SRP window will show the actual quiet zone and required quiet zone.

Click the viewing box to locate the failure.

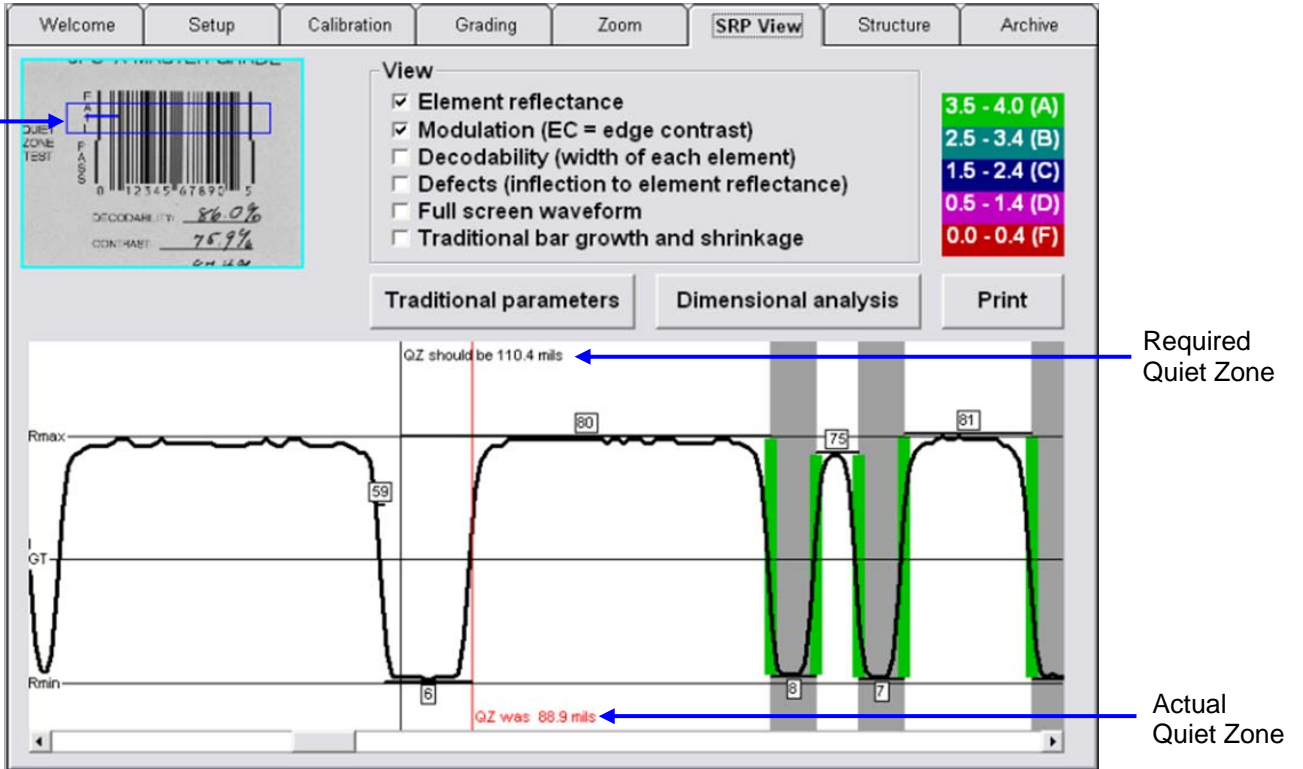

Traditional Bar Growth and Shrinkage

Select this option to view bar growth and shrinkage information.

Welcome
Setup
Calibration
Grading
Zoom
SRP View
Structure
Archive

View

- Element reflectance
- Modulation (EC = edge contrast)
- Decodability (width of each element)
- Defects (inflection to element reflectance)
- Full screen waveform
- Traditional bar growth and shrinkage

Traditional parameters
Dimensional analysis
Print

This line

Parameter	Bar 1	Bar 2	Bar 3	Bar 4	Bar 5	Bar 6	Bar 7	Bar 8
Ideal	0%	0%	0%	0%	0%	0%	0%	0%
Symbol mean	+5%	+6%	+6%	+5%	+4%	+4%	+4%	+5%
Symbol min	+3%	+3%	+4%	+3%	+3%	+3%	+3%	+2%
Symbol max	+6%	+8%	+7%	+6%	+6%	+5%	+6%	+6%

Traditional Parameters Button

Click the **Traditional parameters** button to view a graphical representation of the barcode. After clicking this button, the following page appears:

Bar	1	2	3	4	5
Ideal size in X	1	1	2	1	2
Ideal size in mils	13	13	26	13	26
Mean size in mils	13.8	13.8	26.7	13.7	25.8
Print growth in mils	0.8	0.8	0.7	0.7	-0.2
Minimum size in mils	13.7	13.6	26.6	13.6	25.7
Maximum size in mils	13.9	13.9	26.8	13.9	26
Growth	+6%	+6%	+5%	+6%	-1%
<end of file>					

For Databar stacked symbols, this feature works independently for each row in the symbol. Click the row of interest to view the traditional parameters for that given row.

The barcode size is measured in Mil or Micron units; this is determined by selecting **English** or **Metric** on the **Setup** tab | **System Settings** section.

Note:

Mil - thousands of an inch (.001)

Micron (also known as micrometer) – 1 millionth of a meter

Options on this page include:

Option	Description
Previous page	Click this button to access the previous page.
Next page	Click this button to access the next page.
Print	Clicking this button prints the barcode parameters.
Save	Clicking this button saves your changes. After clicking this button, enter a file name and click the Save button. All files are saved as delimited files using the vertical bar () as the record separator.
Exit	Clicking this button exits the screen. The SRP View Tab main screen appears.

Dimensional Analysis Button

Click the **Dimensional analysis** button to view the measurement of each bar and space in the barcode.

10-Line Grading Button

Because the LVS-95XX System uses camera-based technology, Microscan is able to analyze many lines throughout the height of a code. The software averages all parameters for each line and reports the overall grade as being the lowest of the averages of all parameters.

The 10-Line Grading button is available to mimic a laser-based or CCD-based verifier where only 10 lines are assessed. These types of verifiers do not average each parameter; they simply average the overall grade for each line.

Note: It is possible you may notice differences between the grades using the multiple line grade (normal mode) and the 10-line grading method.

Print Button

Click the **Print** button to print the Scan Reflectance Profile (SRP). If a certain View is selected, the printer creates a color-coded SRP.

Structure Tab

Embedded data	Description	Value
<232>	FNC1	<FNC1>
01	Global Trade Item Number (GTIN)	(01)
00001234567895	Global Trade Item Number (GTIN)	00001234567895
90	Information Mutually Agreed Between Trading Partners	(90)
1234567890	Data Field	1234567890

Many companies and organizations throughout the world create barcode labels according to a set of rules used to standardize how barcode data is to be structured in order to easily transfer trade-related information between two parties. For the most part, these rules were created and governed by an international group called ISO/IEC. These rules can be found in a publication entitled ISO/IEC 15434 and are commonly called the syntax or semantics of the data.

Currently, the LVS-95XX system is capable of analyzing the data structure of all barcode symbologies. The above example is for a GS1-128 barcode symbol.

Printing

- Click the **Print** button to send the report to a printer.
- To view an HTML image of the final Verification Report, right-click on the **Print** button. The HTML version can be saved as a PDF file by downloading free PDF convertor software from the Internet to the computer. See the “**1. Overall Grade**” section, within the “**Grading Tab**” section, for detailed instructions on saving the HTML version as a PDF file.

Use the Data Structure Analysis

1. Go to the **Grading Tab** screen and grade the target label as you normally would (certain labels have two parts to their barcode: **1D** (the linear part) and **2D** (the composite part)). The Data Structure Analysis software analyzes only which part you have selected.
2. After a grade has been established, select the **Structure** Tab. The analysis will be completed shortly.

Generally speaking, the **Structure Tab** screen is used by personnel who are familiar with Application Identifiers and with data semantics. It is not the intention of this manual nor Microscan to educate an operator how to translate the meaning of the structure analysis. It is only Microscan's intention to divide the information into sections in accordance with industry standards.

The screenshot displays the 'Structure' tab of the Microscan software. The interface includes a top navigation bar with tabs: Welcome, Setup, Calibration, **Grading**, Zoom, SRP View, Structure, and Archive. The main area is divided into several sections:

- Overall grade:** 3.3/10/660 (B). Includes a 'Print' button and an 'Auto' checkbox.
- ISO Grading:** Radio buttons for 'Full' (selected) and 'Pass/Fail'.
- View:** Radio buttons for 'Overall grade', 'Contrast', 'Modulation', 'Decodability', 'Defects', 'OCR', and 'Zoom'.
- ISO/IEC Parameters:** Radio buttons for '1D: linear' (selected) and '2D: CC, PDF, DM, etc.'. Below this, the barcode data is displayed: 010061414199999610AB C12321321CBA.
- Barcode Analysis Results:**
 - Symbology: GS1-128
 - Xdim: 0.283mm
 - Edge determ: PASS
 - Min Reflect: PASS
 - Minimum EC: PASS 50%
 - Decode: PASS 317
 - Quiet zone: PASS
 - Contrast: 3.7 (A) 73%
 - Modulation: 3.3 (B) 68%
 - Decodability: 4.0 (A) 75%
 - Defects: 4.0 (A) 6%
 - Blemish: 4.0 (A) 0%
- Grade Legend:** A row of colored boxes representing grade ranges: 3.5-4.0 (A) in green, 2.5-3.4 (B) in teal, 1.5-2.4 (C) in blue, 0.5-1.4 (D) in purple, and 0.0-0.4 (F) in red.

The central image shows a physical barcode label with the text 'F28A GS1-128 tested with FNC1 10 mil' and the barcode data '0 0614141 99999 6 (10) ABC123 (21) 321C' printed below it.

Example of an EAN/UCC barcode label using an Application Identifier.

Data Structure Analysis Example

The above Figure is a screenshot of the **Grading** Tab verifying an EAN/UCC barcode label. The transmitted encoded data is displayed in the upper right box. Clicking on the **Structure** Tab, the data is divided into its data structural format.

Embedded data	Description	Value
<232>	FNC1	<FNC1>
01	Global Trade Item Number (GTIN)	(01)
00001234567895	Global Trade Item Number (GTIN)	00001234567895
90	Information Mutually Agreed Between Trading Partners	(90)
1234567890	Data Field	1234567890

Structure Tab showing the barcode data divided into its data structure format.

WARNING: The checking of Data Structure is complex and extensive. Microscan is attempting to define all Data Structures but we may make an occasional error or may not have a Data Structure defined that you require. If this is the case, please contact Microscan and we will make the needed changes and/or additions in a future release of the software. We thank you in advance for your help and cooperation.

Archive Tab

The screenshot shows the 'Archive' tab interface. At the top, there is a navigation bar with tabs: Welcome, Setup, Calibration, Grading, Zoom, SRP View, Structure, and Archive. The 'Archive' tab is selected. Below the navigation bar, there is a main content area. On the left side of this area, there is a sidebar with several buttons: 'Import image from file', 'Export image to file', 'Recent reports (last 30 days)', 'Delete prior to specific date', 'Software version history', 'Audit trail report', 'Calibration report', 'Reference report', 'Export reference data', 'Change SQL connection', 'Create backup database', and 'Browse backup database'. The main content area displays a table of reports with the following columns: ReportID, SectorID, LclTime, Reference, OverallGrade, and De. The table contains 18 rows of data, with ReportID ranging from 494 to 511. Below the table, there are two radio buttons: 'Preview results in above table' (which is selected) and 'Generate HTML file (for printing)'. At the bottom of the interface, there is a 'Query:' field with a dropdown menu showing 'Select ReportID, SectorID, LclTime, Reference, OverallGrade, DecodedText Fr...' and an 'Execute query' button.

ReportID	SectorID	LclTime	Reference	OverallGrade	De
494	1	22-Dec-2009 10:21		4.0/10/660 (A)	000
495	1	22-Dec-2009 10:21		4.0/10/660 (A)	000
496	1	22-Dec-2009 10:21		4.0/10/660 (A)	000
497	1	22-Dec-2009 10:25		4.0/10/660 (A)	000
498	1	22-Dec-2009 10:36		4.0/10/660 (A)	000
499	1	22-Dec-2009 10:47		2.7/06/660 (B)	012
500	1	22-Dec-2009 10:47		2.7/06/660 (B)	012
501	1	22-Dec-2009 10:47		2.7/06/660 (B)	012
502	1	22-Dec-2009 10:47		2.8/06/660 (B)	012
503	1	22-Dec-2009 10:48		2.8/06/660 (B)	012
504	1	22-Dec-2009 10:48		1.0/06/660 (D)	012
505	1	22-Dec-2009 10:48		2.7/06/660 (B)	012
506	1	22-Dec-2009 10:48		3.7/06/660 (A)	012
507	1	22-Dec-2009 10:48		3.7/06/660 (A)	012
508	1	22-Dec-2009 10:48		3.7/06/660 (A)	012
509	1	22-Dec-2009 10:48		3.7/06/660 (A)	012
510	1	29-Dec-2009 11:08		4.0/06/660 (A)	012
511	1	29-Dec-2009 11:08		4.0/06/660 (A)	012

The **Archive** tab allows you to view various reports and files (stored in an SQL-compatible database), and perform certain database functions. Options include:

- Import Image from file
- Export Image to File
- Recent Reports (last 30 days)
- Delete prior to specific date
- Software Version history files
- Audit Trail Report
- Calibration Report (history)
- Reference Report
- Export reference data
- Change SQL connection
- Create backup database
- Browse Backup database

Each option is described in the sections below.

Import Image from File

The “Import Image from File” button allows you to import a .bmp image into the LVS-95XX software for the purpose of analyzing and troubleshooting the image. This feature is used for remote troubleshooting assistance when an image needs to be analyzed by a Microscan technician or other employees internal to your company who also have an LVS-95XX system.

IMPORTANT: Only Bitmap (.bmp) files that have been exported from the LVS-95XX software can be imported. See the next section entitled “Export Image to File” for more information on exporting images.

To import an image:

1. Click the “Import image from file” button. The “Open” dialog box appears.

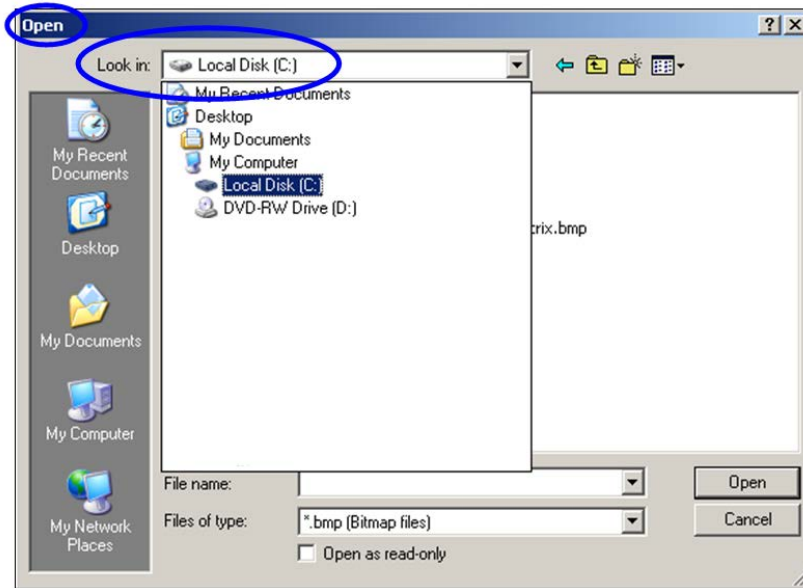

2. In the “Look in” list, click the folder that contains the image you want to import.
3. Click the image, and then click “Open.” The image appears on the “Archive” tab.

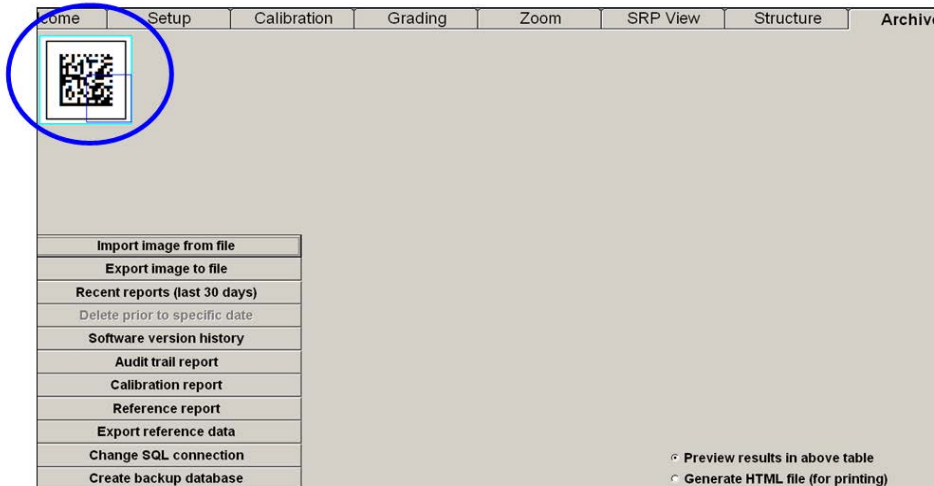

4. Click the "Grading" tab and grade the barcode. All analysis tools perform the same as if the image was taken live from the camera. The image below shows the camera switch located on the Setup tab screen.

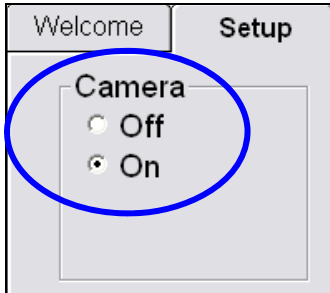

WARNING: When loading an imported image, the LVS-95XX camera is automatically turned "Off." After work is completed with the imported image, the internal camera must be manually turned back on. Go to the "Setup" tab and turn the camera back "On."

Export Image to File

The “Export Image to file” button is used for remote troubleshooting assistance when an image needs to be analyzed by a Microscan technician or other employees internal to your company using an LVS-95XX system. Click this button to export an image, which can then be imported into another computer housing the LVS-95XX software for the purpose of analyzing and evaluating the image. Images are exported as Bitmap (.bmp) files.

To export an image:

1. Click the “Export image to file” button. The “Save As” dialog box appears.

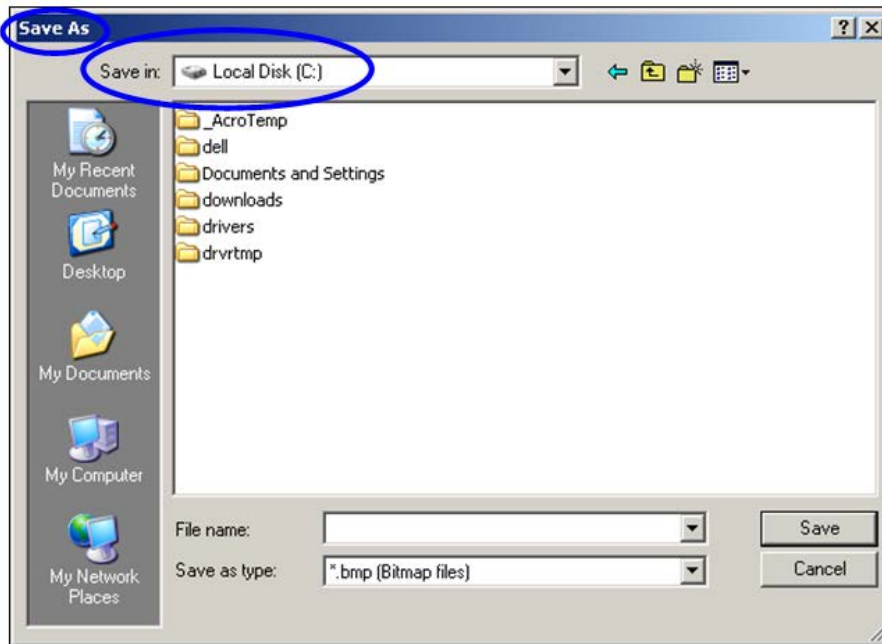

2. In the “Save in” list, click the folder where you want to save the image. Then, click “Save.” The file is saved to the designated location.

Recent Reports (Last 30 Days)

You can recall any report from the archive. When you do, the data is the same as it was when the report was generated with the exception of the current date/time being attached on the bottom of the report. For reports older than 30 days, you must enter the proper software commands using SQL language into the "Query" box. For those who may not be accustomed to SQL commands, the software has made it easy to use. For instance, by choosing "Recent Reports" the Query box might contain the following command:

Select ReportsID,ImageID,LocalTime From Reports Where
LocalTime>=#23-Apr-2005 11:25# Order By ReportID



The Query box and Execute Query Box

Use this same command but change the "23-Apr-2005" date to a desired period of time. Then press the **Execute query** button. The software remembers the original command string as well as the modified command string. All of the different files and reports can be altered in the same manner.

Delete Prior to Specific Date

Click the "Delete Prior to Specific Date" button to delete old files. Use the calendar feature to select the desired date prior to which all data will be deleted, and then click the **OK** button.

The date will display according to your Regional settings.

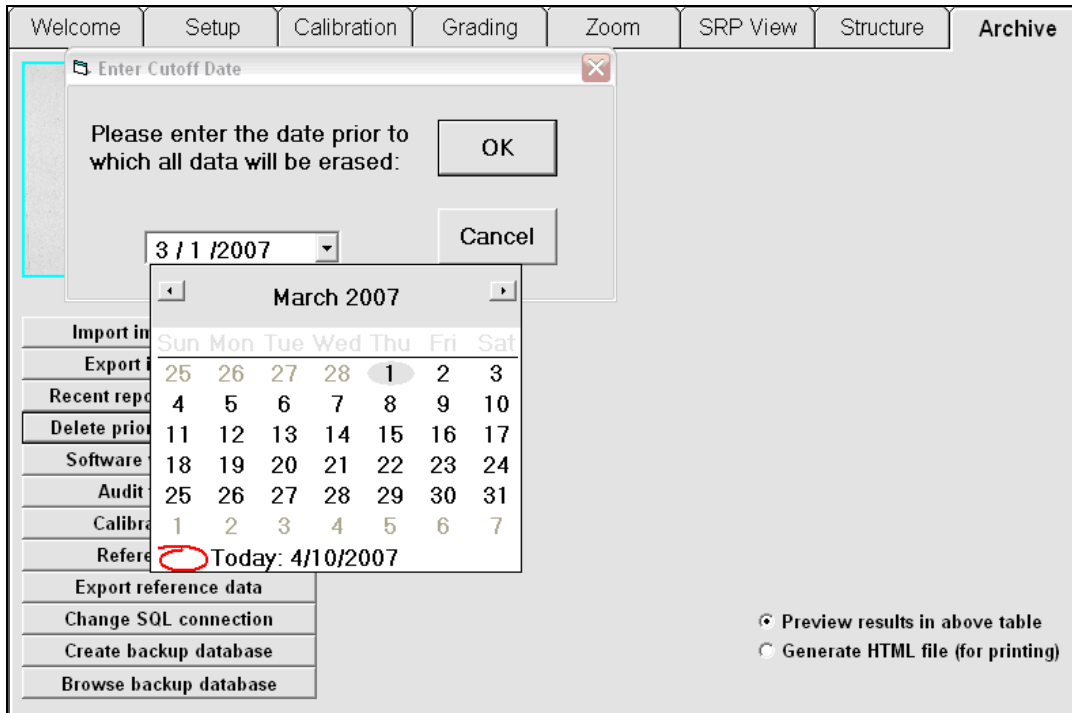

Only users who are granted the “Allow change Setup Options” permission are able to delete files; this permission can be found by clicking the “Setup operators” button on the “Setup” tab screen.

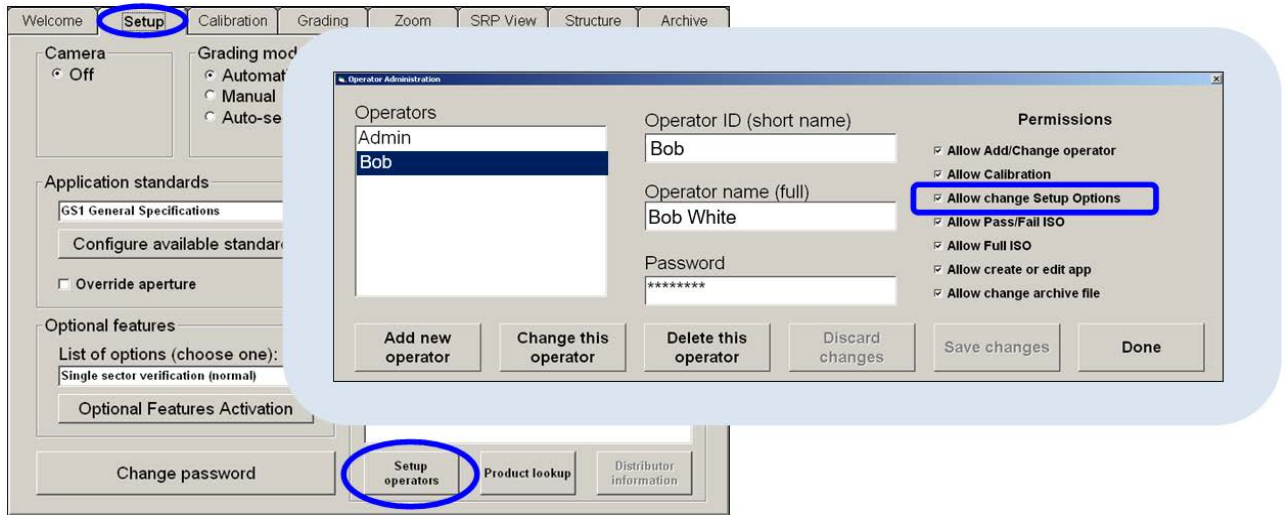

The “Delete prior to specific date” button is disabled for users not granted the “Allow change Setup Options” permission.

Import image from file
Export image to file
Recent reports (last 30 days)
Delete prior to specific date
Software version history
Audit trail report
Calibration report
Reference report
Export reference data
Change SQL connection
Create backup database
Browse backup database

This button is disabled for users not granted the “Allow change Setup Options” permission.

WARNING: A full database causes the LVS-95XX software to stop functioning. A warning message, along with further instructions, appears when the database reaches 50% capacity, and every 5% thereafter. For example, at 50% capacity, a warning message appears and if ignored, the message re-appears at 55% capacity, and then at 60% capacity.

Software Version History

This report historically lists all software changes generated by the factory throughout the years. It lists when the change was performed, the software version number, and a simplified explanation of what was performed.

Audit Trail Report

This report lists the Operator ID along with the date/time and states what action was being taken. The Audit trail is updated every time the software detects an administrative change; this includes the following:

- When an operator logs on or off
- When the entire program is started or stopped
- Changes to the configuration of the Setup Tab screen (such as time-outs)
- Database changes
- Calibration time outs
- Changes in permission levels
- Calibration
- Creation or deletion of an operator

Calibration Report

This report lists every time calibration was achieved along with a date/time stamp and who performed it. If there are any problems or questions, this report allows the operator to view exactly what the calibration process did and why.

Reference Report

This report contains all verification reports for a given reference. The reference name (free form text) is entered in the Reference box located on the Setup Screen.

After clicking this button, only the reports for that reference are displayed and can be exported by clicking the Export reference data button.

Export Reference Data

The Reference report is a text file that can be placed into another database file if desired. Clicking this button sends the Reference report to another file.

After clicking this button, the **Save As** window appears. Select the desired file location and name, and then click the **Save** button.

Note: Within this report a vertical bar, instead of a comma, is used to separate the data.

Change SQL Connection

The default location for all archived databases are stored on the LVS-95XX system hard drive. However, sometimes a company would like to send these reports to an external drive; to do this, click the “Change SQL connection” button on the “Archive” tab. The “Setup Connection to SQL Database” screen appears.

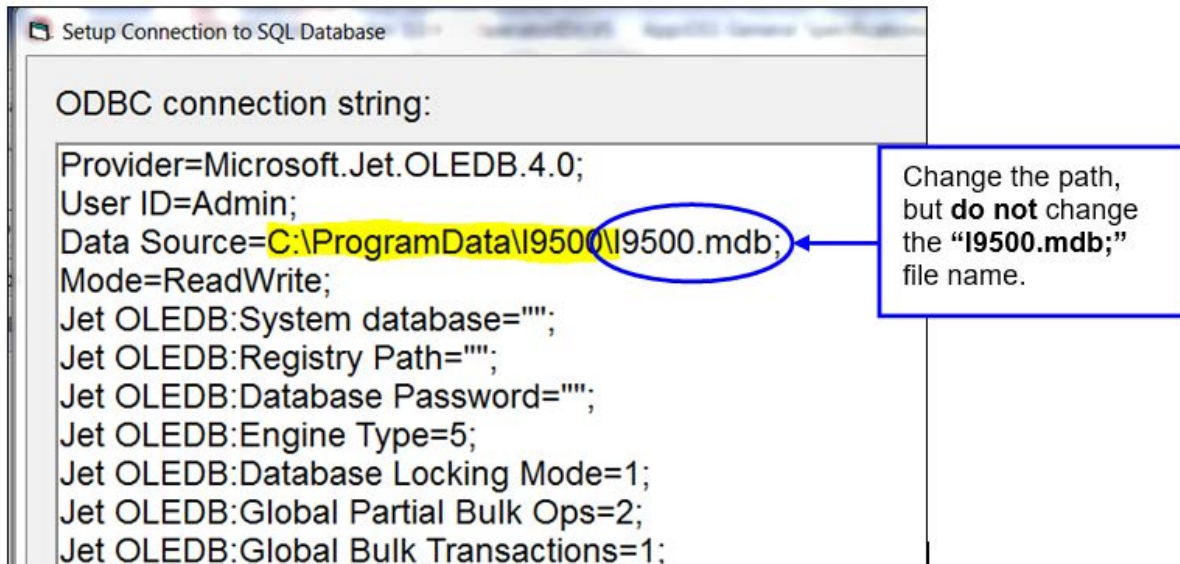

1. Change the “Data Source” path to the desired location (see yellow highlight above), but do not change the I9500.mdb; file name. Changing the “Data Source” path creates a new database in the new location.
2. When changes are complete, click the “Ok” button.
3. The “Confirm Populate Database” message appears. When changing source locations, you must choose to populate the new database with LVS-95XX information to carry over the factory calibration and operator credentials.

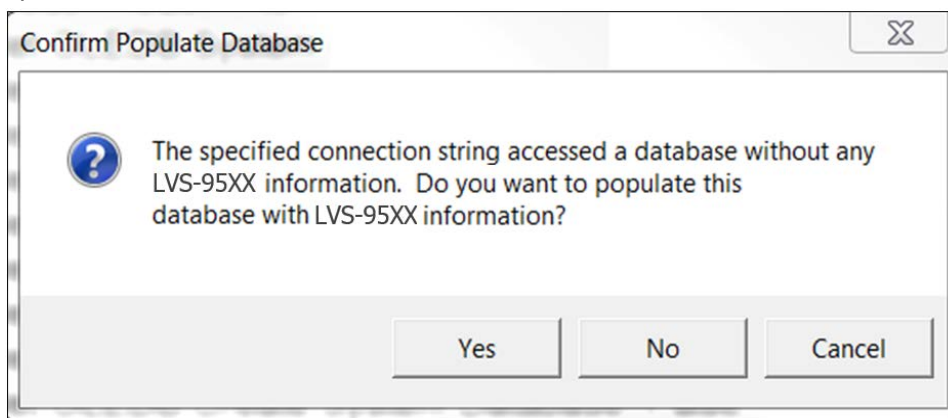

- Click **Yes** to populate the new database with the LVS-95XX information.
- Click **No** to NOT populate the new database with the LVS-95XX information. This option is not recommended, as it causes the loss of factory calibration requiring Microscan intervention to continue using the LVS-95XX software.
- Click **Cancel** to cancel populating the database. No changes are saved.

4. If selecting **Yes** to the message above, the following message appears.

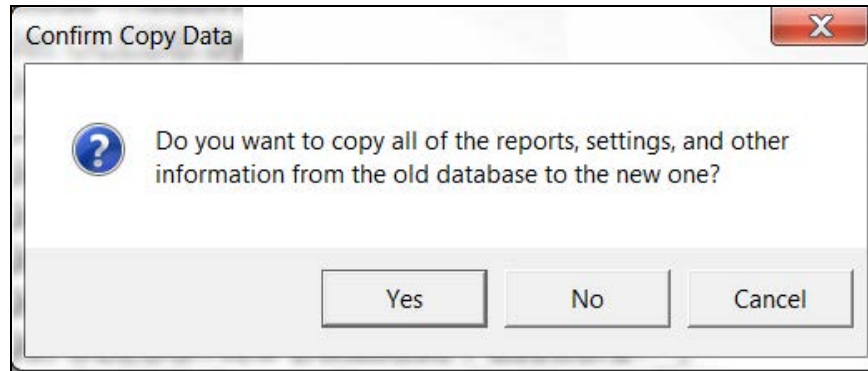

- Click **Yes** to copy the reports, settings and other information from the old database to the new database. It is not required to select **Yes**, but is recommended because reports, settings and other information not copied to the new database will be lost and some settings require you to contact Microscan for the password of the day to restore the settings.
 - Click **No** to not copy reports, settings and other information from the old database to the new database. This action may result in the loss of reports or settings and will require you to contact Microscan for the password of the day to restore the settings.
 - Click **Cancel** to exit the window. No changes are saved.
5. If the database already exists in the new source location, the following message appears allowing you to choose one of the following options:

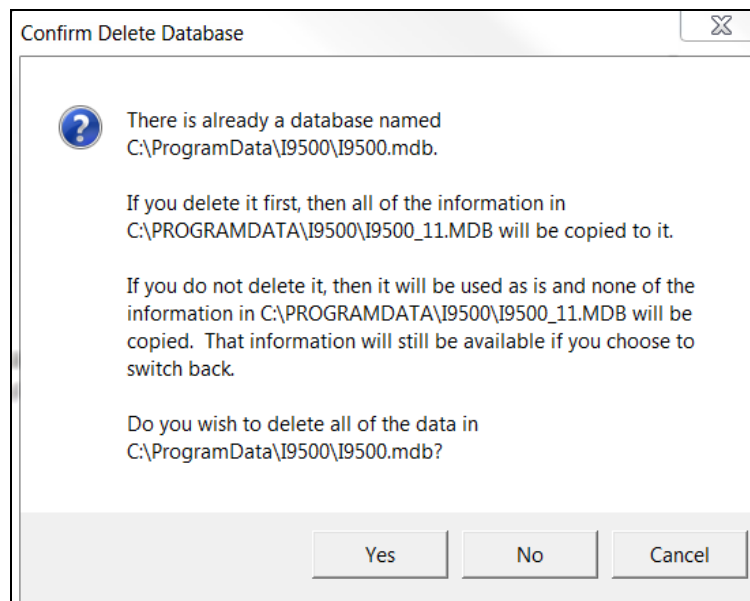

- Click **Yes** to delete the database in the new source location and populate with the new database.
- Click **No** to not delete the database in the new source location. The new database will not be copied to the new source location.
- Click **Cancel** to exit the process and not save any changes.

Create Backup Database

1. To create a backup database, click this button. The **Save As** window appears.
2. Select the desired location to store the database, then click the **Save** button.

Note: A default file name appears in the File name field (for example: I9500_10_Apr_2007.mdb). If desired, change the name of the file name by typing a new name in the File name field.

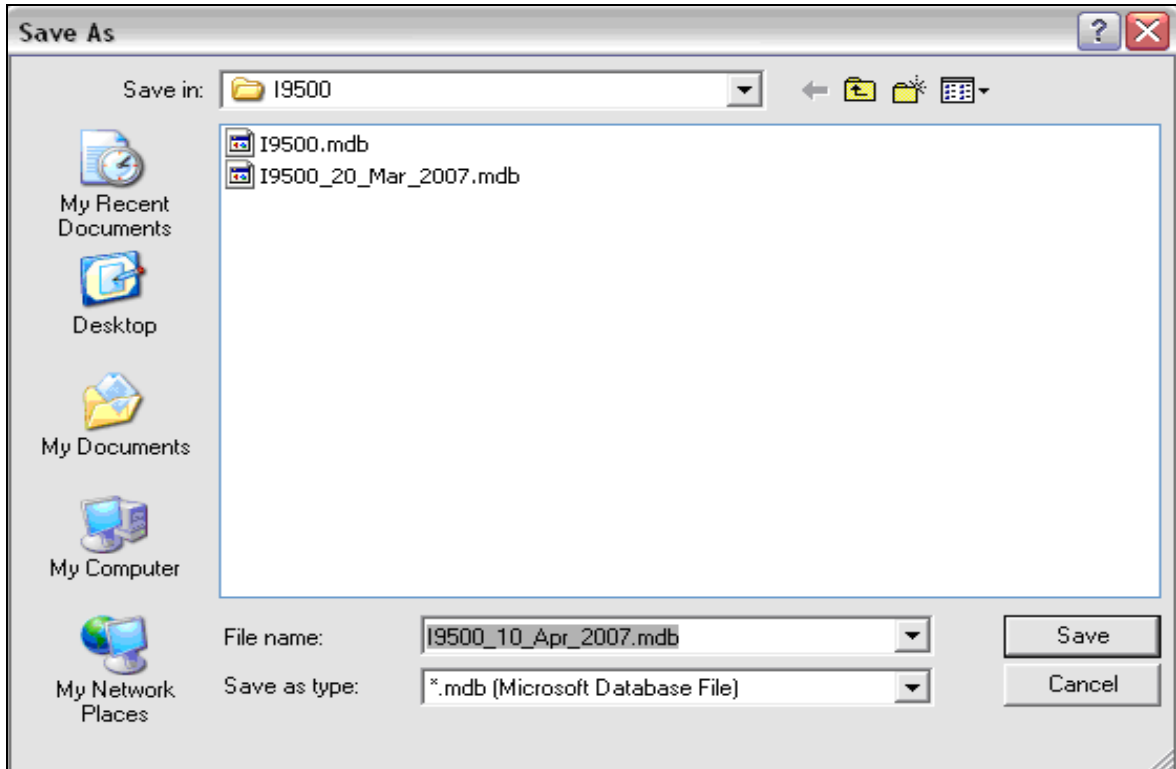

Browse Backup Database

1. To locate and browse a backup database, click the **Browse Backup Database** button.
2. Select the database from the list of backup databases.

Available options include:

- Recent reports (last 30 days)
- Software version history
- Audit trail report
- Calibration report
- Reference report
- Export reference data
- Cancel browse backup



Print an Archived Report

At the bottom right of the **Archive Tab** screen is the **Generate HTML file (for printing)** option. When this option is activated, the Archived Report will print.

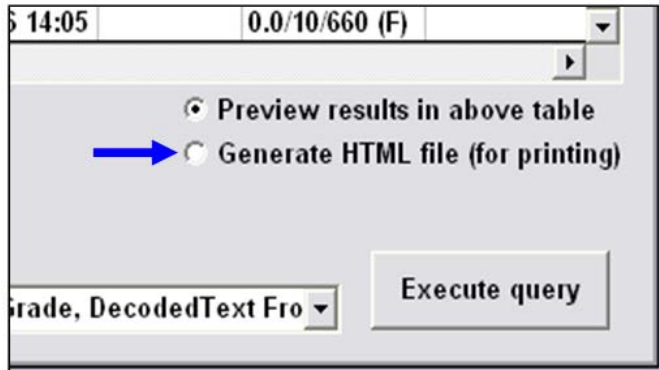

Preventive Maintenance Schedule

LVS-9510

To maintain a clean and clear appearance, clean only the outside of the viewing window with a commercially available household glass cleaner, such as Windex®, Glassex®, VISS®, and Mr. Muscle®. Do not use an industrial-strength glass cleaner. Do not clean the inside of the viewing window.

Replace the Calibrated Conformance Standard Test Card every two years.

The LVS-9510 light tray has LED lights which have a life span of approximately 10,000 hours; thus, there should be no replacement concerns with the light tray. Contact Microscan or your Microscan distributor with any questions.

LVS-9570

Sensor Cleaning Instructions:

The sensor window may need to be cleaned daily, depending on use. Debris on the sensor window may cause the LVS-9570 to not grade accurately.

Locate the following supplies:

- One of the following:
 - Commercially available household glass cleaner, such as Windex®, Glassex®, VISS®, and Mr. Muscle®
 - Rubbing alcohol
 - Camera lens cleaning solution
- Soft, lint-free, non-abrasive towel or cloth, or tissue paper designed to clean a lens

Dampen the cloth with the cleaning solution and wipe the window. Inspect the window closely, looking for any label debris that may get stuck on the window. Do not scrape the window with a sharp object as this may damage the window causing the system to not grade correctly.

Any damage to the sensor window will be detected during the calibration process.

- DO NOT directly spray the sensor glass with glass cleaner; always spray a towel or cloth with glass cleaner and then gently wipe the sensor glass.
- DO NOT use an industrial-strength glass cleaner.

Rubber Roller Instructions:

The LVS-9570 rubber roller may need cleaning periodically, as it is important to keep the roller free of debris, adhesive buildup and other surface materials.

Locate the following supplies:

- Dishwashing liquid
- 1 cup of water
- Lint-free cloth

Warning: Use only dishwashing liquid to clean the rubber roller. Do not clean the roller with alcohol, window cleaner or petroleum-based products, as this causes the rubber to crack.

Mix a few drops of dishwashing liquid into a cup of water and place a lint-free cloth into the solution until the cloth is saturated. Ring out the cloth so that no water drips from the cloth. Wipe down the rubber roller surface, removing any debris. As you wipe, turn the roller to clean the entire surface. Then, rinse out the cloth and wipe down the rubber surface again to remove any dishwashing liquid from the roller. Allow the roller to dry before using.

Window Scratches:

When the sensor window is scratched, it may cause a streak in the image. This streak may cause the barcode grade results to be distorted if the streak is located within the barcode image. When a scratch occurs, you may need to return the system to Microscan (or your Microscan distributor) for sensor replacement. Contact your Microscan representative for more information.

Replace the Calibrated Conformance Standard Test Card every two years.

LVS-9580

Cleaning Instructions:

The LVS-9580 window may need to be cleaned daily, depending on use. Debris on the window may cause the LVS-9580 to not grade accurately.

Locate the following supplies:

- Commercially available household glass cleaner, such as Windex®, Glassex®, VISS®, or Mr. Muscle®. DO NOT use an industrial-strength glass cleaner.
- Soft, lint-free, non-abrasive towel or cloth

Dampen the cloth with the household glass cleaner and gently wipe the window. Inspect the window closely, looking for any label debris that may be stuck on the window. Do not scrape the window with a sharp object as this may damage the window. Any damage to the window will be detected during the calibration process.

- DO NOT directly spray the window with glass cleaner; always spray a towel or cloth with household glass cleaner and then gently wipe the window.
- DO NOT use an industrial-strength glass cleaner.

Replace the Calibrated Conformance Standard Test Card every two years.

LVS-9505

Replace the Calibrated Conformance Standard Test Card every two years.

The LVS-9505 light tray has LED lights which have a life span of approximately 10,000 hours; thus, there should be no replacement concerns with the light tray. Contact Microscan or your Microscan distributor with any questions.

LVS-9500

Monthly:

- Using 60 to 80 PSI (400-480 kPa) of positive air flow, clean the lens mounted inside the LVS-9500 housing; this ensures the removal of small particles on the surface of the lens.
- Vacuum the two air intake holes located under the main housing; this removes any build-up of particles trapped in the two filters.

For Systems Using a DC Fluorescent Light Tray: Replace the DC Fluorescent Light Tray every two years; these special lights diminish in brightness over several years. Replacing the Light Tray every two years ensures continuous calibration levels.

For Systems Using LED Lights: The LVS-9500 light tray has LED lights which have a life span of approximately 10,000 hours; thus, there should be no replacement concerns with the light tray. Contact Microscan or your Microscan distributor with any questions.

Replace the Calibrated Conformance Standard Test Card every two years.