

# Quick Start Guide

## QX Hawk C-Mount Industrial Imager



**MICROSCAN.**

P/N 83-116801 Rev C

### Step 1 — Check Hardware

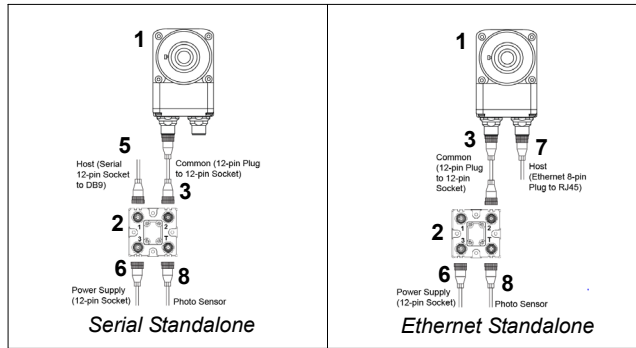

**Caution:** Be sure that all connections are secure **BEFORE** applying power. Power down **BEFORE** disconnecting any cables.

Item	Description	Part Number
1	QX Hawk C-Mount Industrial Imager	FIS-6801-XXXXG
2	QX-1 Interface Device	98-000103-02
3	QX Cordset, Common, M12 12-pin Plug to M12 12-pin Socket, 1 m	61-000162-01
4	QX Cordset, Host, Serial, M12 12-pin Plug to DB9, 1 m	61-000152-01
5	QX Cordset, Host, Serial, M12 12-pin Socket to DB9, 1 m	61-000153-01
6	QX Power Supply, M12 12-pin Socket, 1.3 m	97-000003-01
7	QX Cordset, Host, Ethernet, M12 8-pin Plug to RJ45, 1 m	61-000160-01
8	QX Photo Sensor, M12 4-pin Plug, NPN, Dark On, 2 m	99-000020-02
9	QX Cordset, C-Mount-to-Smart Series Light (not shown)	61-000207-01

**Note:** Additional cordsets and accessories are available in the Microscan Product Catalog.

### Step 2 — Connect the System

**Important:** When connecting cordsets to the QX Hawk C-Mount and QX-1, align the pins first and then push the connector into place. **Do not twist** the connectors, as this will bend the pins.

**Important:** Do not attempt to power more than four imagers with a single power supply in a daisy chain configuration. Add a QX-1 and one power supply for every four additional imagers in the daisy chain.

#### RS-232

1. Connect the Serial Communication Cable from "A" on the QX Hawk C-Mount to "2" on the QX-1.
2. Connect the host cable from "1" on the QX-1 to the host computer.
3. Connect the photo sensor to "T" on the QX-1.
4. Connect the power supply to "3" on the QX-1.
5. Plug in the power supply.

#### Ethernet

1. Connect the Ethernet Cable from "B" on the QX Hawk C-Mount to the network.
2. Connect the power supply to "A" on the QX Hawk C-Mount.
3. Connect the photo sensor to "T" on the QX-1.
4. Plug in the power supply.

### Step 3 — Position the Imager

1. Position the imager at a focal distance of one inch or more from a test symbol.
2. Tip the imager relative to the symbol to avoid the glare of direct (specular) reflection. The case parting line should be perpendicular to the plane of the symbol by either pitching the symbol or the imager as shown.
3. Symbols can be rotated (tilted) at any angle; however, for best results symbols should be aligned with the field of view. In the case of linear symbols, aligning the bars in the direction of their movement (ladder orientation) will minimize the chances of blurring and will result in more consistent decodes.

**Important:** Avoid excessive skew or pitch. Maximum skew is  $\pm 30^\circ$ ; maximum pitch is  $\pm 30^\circ$ .

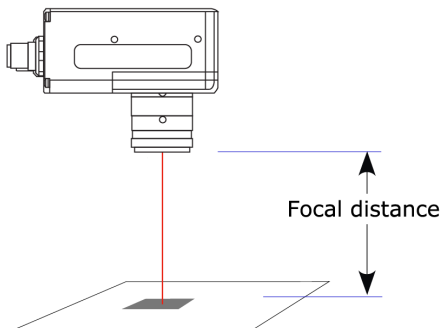

### Step 4 — Install ESP

ESP Software can be found on the Microscan Tools Drive that is packaged with the QX Hawk C-Mount.

1. Follow the prompts to install ESP from the Tools Drive.
2. Click on the ESP icon to run the program.



**Note:** ESP can also be installed from the **Download Center** at [www.microscan.com](http://www.microscan.com).

#### Minimum System Requirements

- 233 MHz Pentium processor
- Windows 7 (32-bit or 64-bit), Vista (32-bit or 64-bit), XP, or 2000 operating system
- Internet Explorer 6.0 or higher
- 128 MB RAM or greater
- 80 MB hard drive space
- 800 x 600 minimum 256 color display (1024 x 768 32-bit color recommended)

Refer to the *QX Hawk Industrial Imager User's Manual* for detailed information about using ESP to configure the QX Hawk C-Mount.

### Step 5 — Select Model

When you start ESP, the model menu will appear:

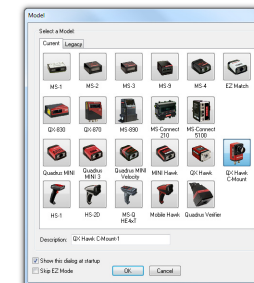

1. Click the button showing the QX Hawk C-Mount.
  2. Click **OK**.
- Note:** You can also simply double-click the button showing your imager to make your selection.
3. Click **Yes** when the following dialog appears:

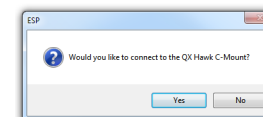

**Note:** If you need to select another model later, click the **Switch Model** button near the top of the screen or use **Model > New Model** in the menu toolbar.

## Step 6 — Connect

To connect using the Connection Wizard:

- Click **Connect** on the menu toolbar, and then select **Connection Wizard**.
- Select **RS-232** or **Ethernet** to activate the appropriate display.
- Configure settings as required by the application, and click **Connect**.

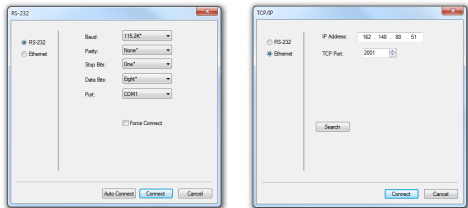

- When a connection is established, the green indicator in the status bar at the bottom right of the screen will be visible:

**CONNECTED** Point-to-Point COM1 115.2K : N : 8 : 1

**Important:** The imager is in **Continuous Read Mode** by default. For best connection results, be sure that no decodable symbols are within the imager's field of view while attempting to connect.

## Step 7 — Locate Symbol

**Locate by ESP**

- In **ESP's EZ Mode**, click the **Locate** button. The symbol in the field of view will appear in the video view beneath the **Locate** and **Calibrate** buttons.
- Center the symbol in the imager's field of view. **Important:** The entire symbol should fall within the field of view (FOV) of the imager. The field of view is what appears in **ESP's Locate/Calibrate** window in **EZ Mode**.
- Click the **Stop** button to end the **Locate** function.



**Locate by EZ Button**

- If you are not connected to a host computer, the EZ Button allows you to locate the symbol in the imager's field of view.
- Hold down the EZ Button for about one second and release when you hear one short beep. The amber **20%** LED will illuminate when the symbol is located. **Note:** To end all EZ Button functions, press the EZ Button once and quickly release.

## Step 8 — Calibrate

Imager settings can be adjusted automatically for optimum performance by either the EZ Button or by **ESP**.

During the calibration routine, the imager will flash its Read Rate percent LEDs and illumination LEDs while searching camera settings and determining the best configuration for decoding symbol data. If unsuccessful, the imager will emit 5 short beeps and stop searching.

**Calibrate by ESP**

- Click the **Calibrate** button.
- The imager will search camera settings to determine the best configuration for decoding symbol data. A successful calibration will display a green frame around the symbol in ESP, and the following message will appear: "Uploading all reader parameters." After a moment the symbol data will be presented in the field below the image display window.

**Calibrate by EZ Button**

- Hold down the EZ Button for about two seconds and release when you hear **two short beeps**. The **20%** and **40%** LEDs will illuminate.
- The imager will search camera settings to determine the best configuration for decoding symbol data. **Note:** To end all EZ Button functions, press the EZ Button once and quickly release.

**Calibrate by Serial Command**

Send **<@CAL>** from a terminal program to begin auto-calibration.

## Step 9 — Test Read Rate

**Read Rate** indicates the number of successful decodes per second achieved by the imager.

**Test Read Rate by ESP**

- Click the **Test** button to start the **Read Rate** test.



If a symbol has been successfully decoded, its data and related information will be presented in the field below the image display window. While the symbol is being decoded, the Read Rate LEDs will indicate the read rate percentage on the top of the unit.

- Click the **Stop** button to end the Read Rate test.

**Note:** Read rate can also be tested using the Read Rate interface in **Utilities**.

**Test Read Rate by EZ Button**

- To start the Read Rate test, hold down the EZ Button about three seconds until you hear **three short beeps**. The **20%**, **40%**, and **60%** LEDs on the top of the unit will illuminate. While the symbol is being decoded, the Read Rate LEDs will indicate the read rate percentage on the top of the unit.
- To end the Read Rate test, press the EZ Button and quickly release.

**Test Read Rate by Serial Command**

You can also start a test with the **<C>** or **<Cp>** command and end it with the **<J>** command.

## Step 10 — Configure and Save

Click the **App Mode** button to make configuration changes.



The following modes are accessible by clicking the buttons at the top of the screen:

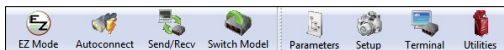

- Click the **EZ Mode** button to return to EZ Mode.
- Click the **Autoconnect** button to establish communication.
- Click the **Send/Recv** button to send or receive commands.
- Click the **Switch Model** button to open the model menu.
- Click the **Parameters** button to show the tree controls for Communication, Read Cycle, Symbologies, I/O Parameters, Symbol Quality, Matchcode, and Diagnostics.
- Click the **Setup** button to access the Camera Setup tree and the interfaces for Video, Evaluation, Calibration, Window of Interest (WOI), Configuration Database, Ordered Output, Output Format, and Dynamic Setup.
- Click the **Terminal** button to display decoded symbol data, and to send serial commands to the imager using text or macros.
- Click the **Utilities** button to show the tabbed interfaces for Read Rate, Counters, Device Control, Differences from Default, Master Database, and Firmware.

**Saving Options**

- Send, No Save.** Changes will be lost when power is re-applied to the imager.
- Send and Save.** This activates all changes in current memory *and* saves to the imager for power-on.