

Configuration and Quick Start Guide Vision HAWK Smart Camera



MICROSCAN.

Copyright ©2011 Microscan Systems, Inc.

P/N 83-126800 Rev D

Step 1 — Check Hardware

The list of hardware below can be used in a variety of applications and configurations. Consult with Microscan for further information about which items are most appropriate for your application.

Item	Description	Part Number
1	Vision HAWK Smart Camera	GMV-6800-XXXXG
2	QX-1 Interface Device	98-000103-02
3	Cordset, Common, M12 12-pin Plug to M12 12-pin Socket, 1 m	61-000162-01
4	Cordset, Host, Serial, M12 12-pin Plug to DB9, 1 m	61-000152-01
5	Cordset, Host, Serial, M12 12-pin Socket to DB9, 1 m	61-000153-01
6	Power Supply, M12 12-pin Socket, 1.3 m	97-000003-01
7	Cordset, Host, Ethernet, M12 8-pin Plug to RJ45, 1 m	61-000160-01
8	Trigger, M12 4-pin Plug, NPN, Dark On, 2 m	99-000020-02
9	Cordset, C-Mount-to-Smart Series Light (not shown)	61-000207-01

Note: Additional cordsets available in the Microscan Product Pricing Catalog.

Step 2 — Connect the System

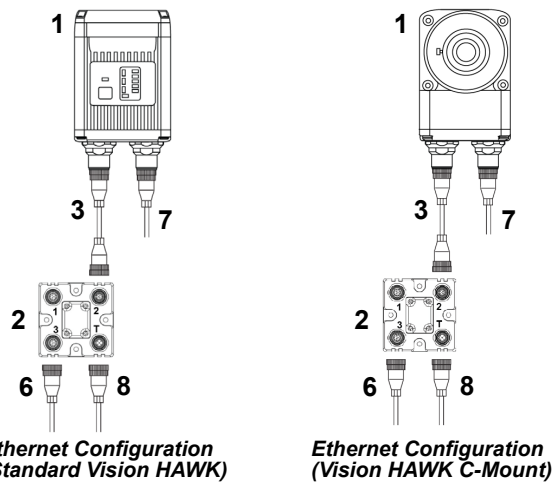

1. Mount the camera (1) as required by the application.
2. Connect the Ethernet Cordset (7) from "B" on the camera (1) to the network.
3. Connect the power supply (6) to "3" on the QX-1 (2).
4. Connect the trigger (8) to "T" on the QX-1 (2).
5. Connect the "Common" Cordset (3) to "2" on the QX-1 and "A" on the camera.
6. Plug in the power supply (6).

Step 3 — Mount and Position the Camera

1. Position the camera at a focal distance of one inch or more from a test object.
 2. Tip the camera relative to the object to avoid the glare of direct (specular) reflection. The case parting line should be perpendicular to the plane of the symbol by either pitching the symbol or the camera as shown. Avoid excessive skew or pitch. Maximum skew is $\pm 30^\circ$; maximum pitch is $\pm 30^\circ$.
- Proper lighting is critical to the success of a machine vision application. The Vision HAWK features integrated high-output lighting (.564mW, 617nm, non-C-Mount version only). Depending on the requirements of your application, you may also need to add external lighting from Microscan's NERLITE family of machine vision lighting products.

Consider the following:

- Is the surface of the object flat, slightly bumpy, or very bumpy?
- Is the surface matte or shiny?
- Is the object curved or flat?
- What is the color of the object or area being inspected?
- Is the object moving or stationary?

Machine vision lighting should maximize contrast of the areas or features being inspected while minimizing the contrast of everything else.

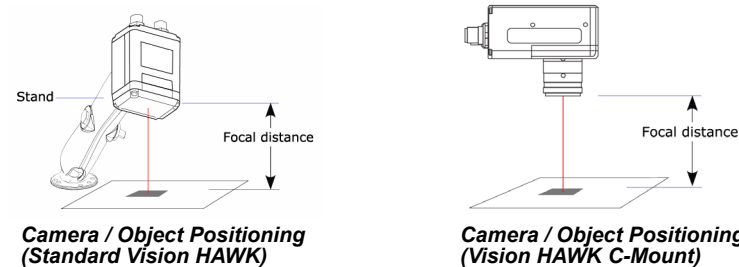

Step 4 — Install AutoVISION

AutoVISION can be found on the Microscan Tools Drive that is packaged with the camera.



1. Follow the prompts to install AutoVISION from the Tools Drive.
 2. Click on the AutoVISION icon to run the program.
- Note:** AutoVISION can also be installed from the **Download Center** at www.microscan.com.

Minimum System Requirements

- Core2Duo processor
- Windows 7 32-bit or XP operating system
- Internet Explorer 7 or higher
- 2GB RAM/128MB Video RAM (Windows 7); 1GB/128MB Video RAM (XP)
- 750MB to 1GB hard drive space
- 16-bit color display
- 3.0 Windows Experience Index (4.0 preferred)

Step 5 — Connect to the Camera

After you launch AutoVISION, you will see the **Select a device to start editing a job** view.

Note: If there is a default job on the camera, AutoVISION will automatically skip the **Connect** step and you will see the **Image** view.

1. Select your camera from the **Select Device** dropdown menu.
 2. Click the **Modify** button beneath the camera settings details to change camera settings.
- Important:** You will need to enter the camera's default username: **Microscan** and password: **vision**.
3. Choose whether you want to create a new job, load a job (.avp) from your PC, or upload a job from the camera.

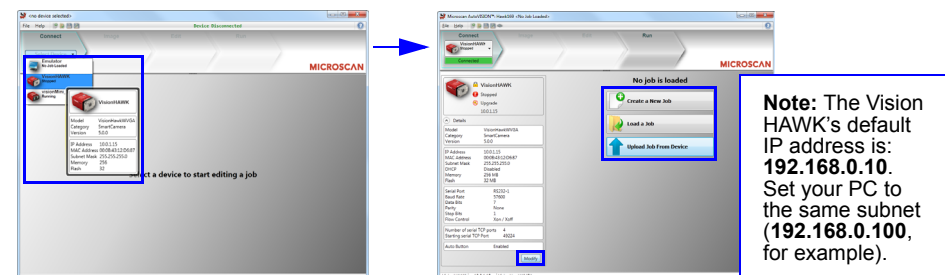

Step 6 — Evaluate a Captured Image and Auto Calibrate

You will see the **Image** view after selecting your device. This view allows you to evaluate your first image capture, providing information such as image size and a histogram. Click the **Auto Calibration** button to set optimal camera parameters automatically. You can also adjust **Exposure**, **Gain**, and **Focus** as needed, and set the desired **Lighting Mode**.

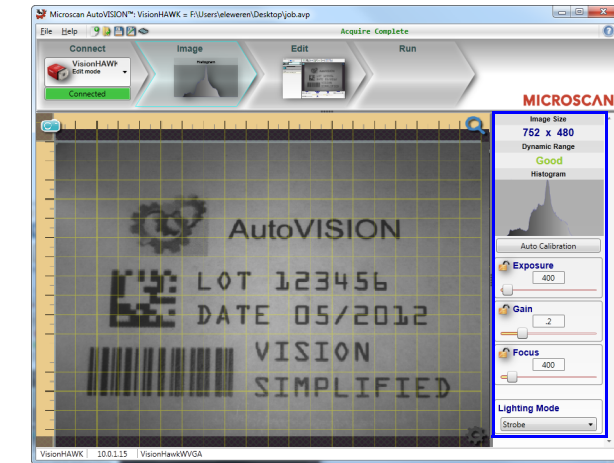

Step 7 — Create Your First Job with AutoVISION

After you have evaluated a captured image and Auto Calibrated the camera in the **Image** view, you will move to the **Create** view. This interface allows you to set camera parameters, add machine vision tools to captured images, set tool parameters, and configure I/O inspection outputs.

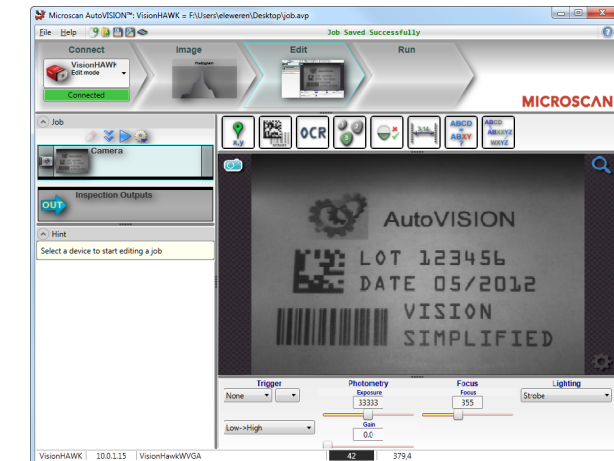

Step 8 — Explore the Interface

The **Create** view features a large image area with tool icons above and tool parameters below. When a tool is selected, its parameters appear below the image area.

Tools that have been added are shown in the job list to the left of the image area, below the **Camera** box. Image settings can be controlled using the icons in the corners of the image area.

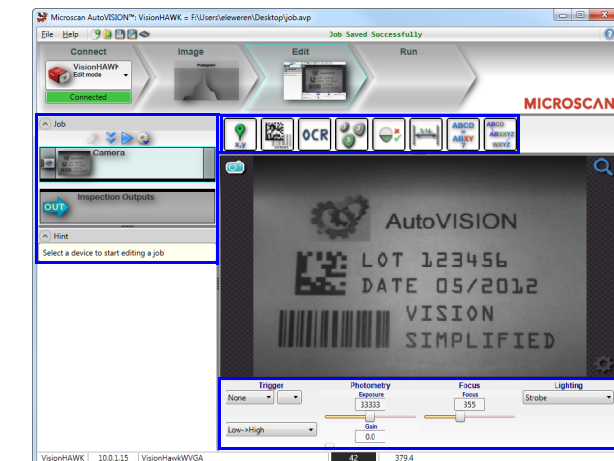

Step 9 — Set Camera Parameters

1. Click on the **Camera** box to the left of the image area.
2. In the camera parameters below the image area, select the desired type of **Trigger**, **Trigger Polarity**, **Photometry** (Exposure and Gain), **Focus**, and **Lighting**.

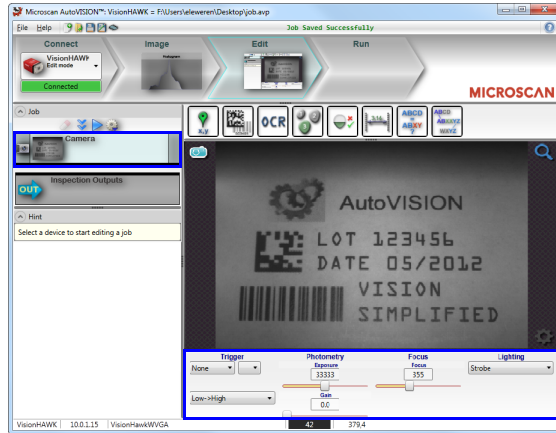

Step 10 — Add Tools to the Job

1. Click on the **Decode Tool** or drag it onto the image area.
2. Use the anchor points at the corners of the region of interest to form a box around the Data Matrix symbol. Leave plenty of space on each side of the symbol.
3. Now add a second Decode Tool and do the same for the 1D symbol below the Data Matrix symbol.
4. Finally, add an **OCR Tool** and drag the region of interest around the area of the image where "123456" is printed.

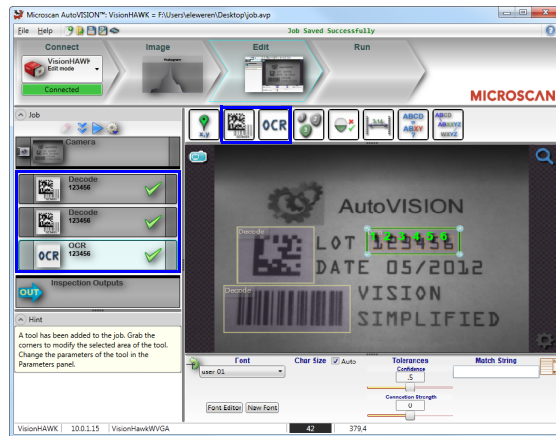

Step 11 — Try Out the Job

Once you have configured the tools as desired, use the arrow icons in the Job area to try the job you have just created.

Note: Most jobs will inspect multiple captured images. If only one image is being inspected, the effect of the arrow icons will not be evident.

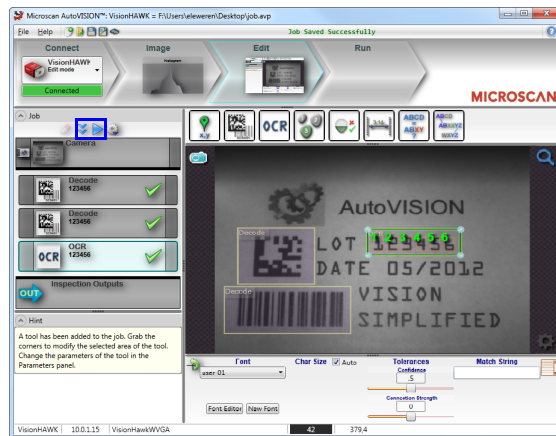

 **Try Out Job Once**

 **Try Out Job in Loop**

Step 12 — Run the Job

When all job parameters are set, click on the **Run** step at the top of the interface. The software will download the vision job just created to the camera and will begin the inspection. Inspection results and the list of active tools are shown at the right of the image view. That information can also be moved below the image area by clicking the orientation buttons above the inspection results area.



Test Jobs

Note: For descriptions of more advanced functionality, such as setting **Inspection Outputs** or using the **Locate Tool** and **Decode Tool's Dynamic Locate** functionality to track multiple tools from image to image, see the help documentation in AutoVISION software.

Decode Tool, OCR Tool, Match Strings Tool, String Format Tool

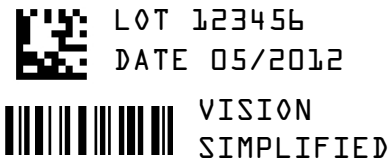

Measure Tool, Count Tool



Measure:
Measure the distance between the jaws of the caliper gauges at left.

Count:
Count the circles on the dice shown at right.



Power Requirements and Pin Assignments

CCD Power Requirements (Standard): 5-28VDC, 200mV p-p max ripple, 170mA at 24VDC (typ.), 15.5 watts (max.)
CMOS Power Requirements (Standard): 5-28VDC, 200mV p-p max ripple, 135mA at 24VDC (typ.), 13 watts (max.)
CCD Power Requirements (C-Mount): 5-28VDC, 200mV p-p max ripple, 130mA at 24VDC (typ.), 15.5 watts (max.)
CMOS Power Requirements (C-Mount): 5-28VDC, 200mV p-p max ripple, 105mA at 24VDC (typ.), 13 watts (max.)

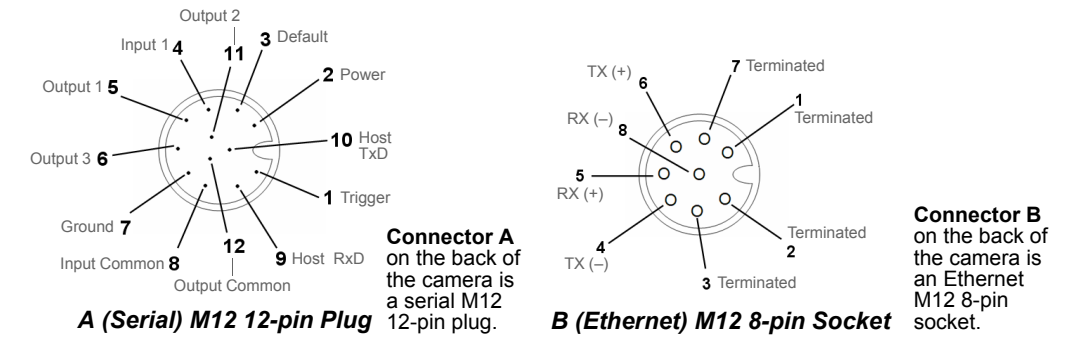

QX-1 Interface Device

Connector T on the QX-1 Interface Device is the trigger connector. **Connectors 1** and **3** are 12-pin plugs, and **Connector 2** is a 12-pin socket. All three connectors can be assigned to bus power and data as required by the application. The two switches at the center of the device allow the user to route signals as needed.

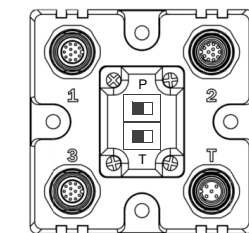

QX-1 Interface Device

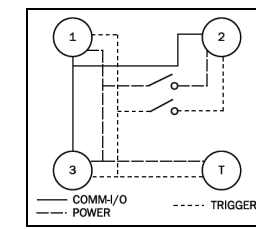

QX-1 Communications - I/O - Power - Trigger

This simple diagram (shown on the base of the QX-1) illustrates how power, communications, I/O, and trigger signal can be routed through the QX-1 device depending on the needs of the application. The switches greatly increase signal routing flexibility.

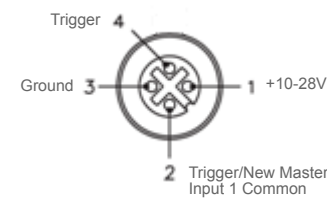

QX-1 Trigger Connector 4-pin Socket

Vision HAWK Accessories

Adapter Plate Kit	98-000143-01
Right Angle Mirror Kit	98-000144-01
Window Replacement	98-000146-01
15° Lens Kit	98-000147-01
30° Lens Kit	98-000147-02
45° Lens Kit	98-000147-03
L-Bracket Kit	98-000148-01
Infrared (IR) Filter	98-000205-01
Glass Window Kit	98-000206-01
L-Bracket Kit, QX Series	98-000148-01
Demo Kit, Vision HAWK	98-000215-01
Microscan Tools Drive	37-000010-01

Note: Additional accessories are available in the Microscan Product Pricing Catalog. See the *Vision Hawk Smart Camera Guide* for Vision Hawk C-Mount accessories.

Vision HAWK Part Numbers

Vision HAWK part numbers follow the format **GMV-6800-CLSYG**:

Comm = 1 for Ethernet;

Lens = 0 for C-Mount, 1 for 15°, 2 for 30°, 3 for 45°;

Sensor = 0 for CCD, 1 for CMOS;

Y (Options) = 0 for AutoVISION, 1 for Custom, 2 for Licensed (Visionscape), 3 for Custom + Visionscape

G = RoHS-Compliant