

Nokia Bluetooth Headset BH-608

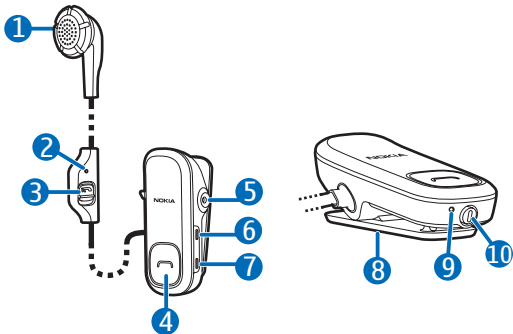

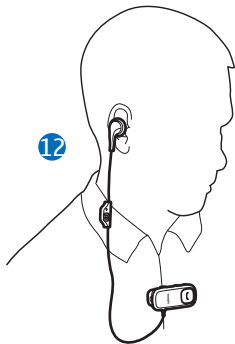
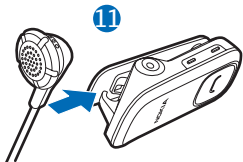

DECLARATION OF CONFORMITY

Hereby, NOKIA CORPORATION declares that this BH-608 product is in compliance with the essential requirements and other relevant provisions of Directive 1999/5/EC. A copy of the Declaration of Conformity can be found at http://www.nokia.com/phones/declaration_of_conformity/.

CE 0197

© 2010 Nokia. All rights reserved.

Nokia, Nokia Connecting People and the Nokia Original Accessories logo are trademarks or registered trademarks of Nokia Corporation. Nokia tune is a sound mark of Nokia Corporation. Other product and company names mentioned herein may be trademarks or tradenames of their respective owners.

Reproduction, transfer, distribution, or storage of part or all of the contents in this document in any form without the prior written permission of Nokia is prohibited. Nokia operates a policy of continuous development. Nokia reserves the right to make changes and improvements to any of

the products described in this document without prior notice.

Bluetooth is a registered trademark of Bluetooth SIG, Inc.

To the maximum extent permitted by applicable law, under no circumstances shall Nokia or any of its licensors be responsible for any loss of data or income or any special, incidental, consequential or indirect damages howsoever caused.

The contents of this document are provided "as is". Except as required by applicable law, no warranties of any kind, either express or implied, including, but not limited to, the implied warranties of merchantability and fitness for a particular purpose, are made in relation to the accuracy, reliability or contents of this document. Nokia reserves the right to revise this document or withdraw it at any time without prior notice.

The availability of particular products may vary by region. Please check with your Nokia dealer for details. This device may contain commodities, technology or software subject to export laws and regulations from the US and other countries. Diversion contrary to law is prohibited.

Introduction

With the Nokia Bluetooth Headset BH-608, you can make and answer calls hands-free with your compatible mobile device. The headset is provided with digital signal processing (DSP) noise cancellation that helps you handle calls in noisy environments.

Read this user guide carefully before using the headset. Also, read the user guide for the device that you connect to the headset.

This product may contain small parts. Keep them out of the reach of small children.



Note: The surface of this device does not contain nickel in the platings. The surface of this device contains stainless steel.

Bluetooth wireless technology

Bluetooth wireless technology allows you to connect compatible devices without cables. The headset and the other device do not need to be in line of sight, but they should be within 10 metres (33 feet) of each other. Connections may be subject to interference from obstructions, such as walls, or other electronic devices.

The headset is compliant with the Bluetooth Specification 2.1 + EDR supporting the Headset Profile 1.1 and Hands-Free Profile 1.5. Check with the manufacturers of other devices to determine their compatibility with this device.

Get started

The headset contains the following parts shown on the title page: earpiece (1), microphone (2), mute key (3), answer/end key (4), charger connector (5), volume up key (6), volume down key (7), clip (8), indicator light (9), and power key (10).

Before using the headset, you must charge the battery and pair the headset with a compatible device.

Parts of the device are magnetic. Metallic materials may be attracted to the device. Do not place credit cards or other magnetic storage media near the device, because information stored on them may be erased.

Charge the battery

Before charging the battery, carefully read "Battery and charger information".



Warning: Use only chargers approved by Nokia for use with this particular model.

The use of any other types may invalidate any approval or warranty, and may be dangerous. Use of unapproved chargers may present a risk of fire, explosion, or other hazard.

When you disconnect the power cord of any accessory, grasp and pull the plug, not the cord.

1. Connect the charger to a wall outlet.
2. Connect the charger cable to the charger connector. The red indicator light is displayed during charging.

Charging the battery fully may take up to 1 hour. Charging the battery for 15 minutes provides up to 3 hours and 30 minutes of talk time.

If the ambient temperature falls below 0°C (32°F) or exceeds 55°C (131°F), charging stops temporarily until the temperature rises to 0°C (32°F) or falls below 55°C (131°F).

3. When the battery is fully charged, the green indicator light is displayed. Disconnect the charger from the headset, then from the wall outlet.

The fully charged battery has power for up to 8 hours of talk time or up to 200 hours of standby time.

To check the battery charge when the headset is not connected to a charger, press the power key when the headset is connected to a mobile device. If the indicator light is green, the charge level is sufficient. If the light is yellow, you may need to recharge the battery soon. If the light is red, recharge the battery.

When the battery charge is low, the headset beeps every 5 minutes and the red indicator light flashes.

Switch on or off

To switch on, press and hold the power key for about 2 seconds. The headset beeps, and the green indicator light flashes slowly while the headset tries to connect to the last one or two connected devices. When the headset is connected to at least one device and is ready for use, the blue indicator light flashes slowly. If the headset has not been paired with a device, it automatically enters pairing mode.

To switch off, press and hold the power key for about 2 seconds. The headset beeps, and the red indicator light is briefly displayed. If the headset is not connected to a device within about 30 minutes, it switches off automatically.

Pair and connect the headset

Before using the headset, you must pair and connect it to a compatible device.

You can pair the headset with up to eight devices, but you can only connect it to a maximum of two devices at a time.

1. Ensure that your mobile device is switched on and the headset is off.
2. If the headset has not been previously paired with a device, switch on the headset. The headset enters pairing mode, and the blue indicator light starts to flash quickly.

If the headset has been previously paired with a device, ensure that the headset is switched off, and press and hold the power key for about 5 seconds until the blue indicator light starts to flash quickly.

3. Within about 3 minutes, activate the Bluetooth feature on your device, and set it to search for Bluetooth devices. For details, see the user guide of your mobile device.
4. Select the headset from the list of found devices.
5. If necessary, enter the passcode **0000** to pair and connect the headset to your device.

In some devices, you may need to make the connection separately after pairing.

When the headset is connected to at least one device and is ready for use, the blue indicator light flashes slowly.

To manually connect the headset to the last used device, press and hold the answer/end key for about 2 seconds (when no other device is connected), or make the connection in the Bluetooth menu of the device.

You may be able to set your device so that the headset connects to it automatically. To activate this feature

in a Nokia device, change the paired device settings in the Bluetooth menu.

Basic use

Change the earpad

The headset may be provided with different sized earpads. Select the earpad that fits the best and is the most comfortable for your ear.

To change the earpad, pull the current earpad from the earpiece, and push the new earpad into place.

Wear the headset

Use the clip to attach the headset to your clothing (12).

To use the headset for calling, gently push the earpiece into your ear.

To have the earpiece within easy reach when you are not using the headset,

insert the earpiece cable between the headset and the clip (11).

Adjust volume

To adjust the volume, press the volume up or down key. To adjust the volume quickly, press and hold the key.

The selected volume level is saved for the device that is currently connected to the headset.

Calls

To make a call, use your mobile device in the normal way when the headset is connected to it.

To redial the number you last called (if your mobile device supports this

feature with the headset), when no call is in progress, press the answer/end key twice.

To activate voice dialling (if your mobile device supports this feature with the headset), when no call is in progress, press and hold the answer/end key for about 2 seconds. Proceed as described in the user guide of the mobile device.

To answer or end a call, press the answer/end key. To reject a call, press this key twice.

To mute the microphone during a call, slide the mute key towards the microphone. To unmute, slide the key to the opposite direction.

To switch a call between the headset and a compatible connected device, press and hold the answer/end key for about 2 seconds.

Manage two calls

To manage two calls with the headset at the same time, your mobile device must support the Bluetooth Hands-Free Profile 1.5, and call waiting must be activated in the device. Call waiting is a network service and is available when the headset is connected to only one device.

To answer a waiting call and end the active call, press the answer/end key.

To answer a waiting call and put the active call on hold, press and hold the answer/end key for about 2 seconds.

To end the active call and make the call on hold active, press the answer/end key.

To switch between the active call and the call on hold, press and hold the answer/end key for about 2 seconds.

Activate or deactivate vibration

You can set the headset to vibrate and flash the indicator light when you receive a call.

By default, the vibration and the indicator light are activated. To deactivate the vibration and the light, press and hold the answer/end key and the volume down key for about 5 seconds when the headset is connected to a device.

To activate the vibration and the light, press and hold the answer/end key and the volume up key for about 5 seconds.

Use the headset with two connected devices

You can connect the headset to two devices at the same time.

To pair the headset to a second device, see "Pair and connect the headset".

Allow connection to two devices

By default, the headset can only be connected to one device at a time. To allow the headset to connect to two devices, switch off the headset, and press and hold the power key and the volume up key for about 5 seconds. The green indicator light flashes once.

To allow the headset to connect to only one device, switch off the headset, and press and hold the power key and the volume down key for about 5 seconds. The yellow indicator light flashes once.

Handle calls

If the headset can connect to two devices at the same time and you use redialling or voice dialling, the call is made on the device that you last used to make a call when the headset was connected to it.

To answer a call on the second connected device and end the active call on the first device, press the answer/end key.

To answer a call on the second connected device and put the active call on hold on the first device, press and hold the answer/end key for about 2 seconds.

To end the active call on the second connected device and make the call on hold active on the first device, press the answer/end key.

To switch between the active call on second device and the call on hold on the first device, press and hold the answer/end key for about 2 seconds.

Clear settings or reset

To clear all the settings from the headset, switch off the headset, and press and hold the power key and the answer/end key at the same time for

about 8 seconds. The headset beeps twice, and the red and green indicator lights alternate. After the settings are cleared, the headset enters pairing mode.

To reset the headset if it stops functioning, even though it is charged, connect the headset to a charger while you press and hold the power key.

Troubleshooting

If you cannot connect the headset to your compatible device, check that the headset is charged, switched on, and paired with the device.

Battery and charger information

This device has an internal, nonremovable, rechargeable battery. Do not attempt to remove the battery from the device as you may damage the device. This device is intended for use when supplied with power from the following chargers: AC-3, AC-4, AC-5, DC-4, and DC-9. The exact charger model number may vary depending on the type of plug. The plug variant is identified by one of the following: E, EB, X, AR, U, A, C, K, B, or UB. The battery can be charged and discharged hundreds of times, but it will eventually wear out. Recharge your battery only with Nokia approved chargers designated for this device.

If a battery is being used for the first time or if the battery has not been used for a prolonged period, it may be necessary to connect the charger, then disconnect and reconnect it to begin charging the battery. If the battery is completely discharged, it may take several minutes

before the charging indicator light is displayed.

Unplug the charger from the electrical plug and the device when not in use. Do not leave a fully charged battery connected to a charger, since overcharging may shorten its lifetime. If left unused, a fully charged battery will lose its charge over time.

Always try to keep the battery between 15°C and 25°C (59°F and 77°F). Extreme temperatures reduce the capacity and lifetime of the battery. A device with a hot or cold battery may not work temporarily. Battery performance is particularly limited in temperatures well below freezing.

Do not dispose of batteries in a fire as they may explode. Dispose of batteries according to local regulations. Please recycle when possible. Do not dispose as household waste.

Never use any charger that is damaged.
Operating times are estimates only.
Actual performance depends on many factors such as device settings selected,

device features being used (or running in the background), battery condition and ambient temperature.

Taking care of your device

Your device is a product of superior design and craftsmanship and should be treated with care. The following suggestions will help you protect your warranty coverage.

- Keep the device dry. Precipitation, humidity, and all types of liquids or moisture can contain minerals that will corrode electronic circuits. If your device does get wet, allow it to dry completely.
- Do not use or store the device in dusty, dirty areas. Its moving parts and electronic components can be damaged.
- Do not store the device in high or cold temperature. High temperatures can shorten the life of electronic devices, damage batteries, and warp or melt certain plastics. When the device warms to its normal temperature from a cold temperature, moisture can form inside the device and damage electronic circuit boards.
- Do not attempt to open the device.
- Do not drop, knock, or shake the device. Rough handling can break internal circuit boards and fine mechanics.
- Do not use harsh chemicals, cleaning solvents, or strong detergents to clean the device. Only use a soft, clean, dry cloth to clean the surface of the device.

- Do not paint the device. Paint can clog the moving parts and prevent proper operation.

These suggestions apply equally to your device, charger, or any accessory.

Recycle

Always return your used electronic products, batteries, and packaging materials to dedicated collection points. This way you help prevent uncontrolled waste disposal and promote the recycling of materials. Check product environmental information and how to recycle your Nokia products at

www.nokia.com/werecycle, or nokia.mobi/werecycle.



The crossed-out wheeled-bin symbol on your product, battery, literature, or packaging reminds you that all electrical and electronic products, batteries, and accumulators must be taken to separate collection at the end of their working life. This requirement applies in the European Union. Do not dispose of these products as unsorted municipal waste. For more environmental information, see the product Eco-Declarations at www.nokia.com/environment.

FCC/Industry Canada notice

This device complies with Part 15 of the FCC Rules. Operation is subject to the following two conditions: 1. This device may not cause harmful interference; and 2. This device must accept any interference received, including interference that may cause undesired operation. This equipment has

been tested and found to comply with the limits for a Class B digital device, pursuant to Part 15 of the FCC Rules. These limits are designed to provide reasonable protection against harmful interference in a residential installation. This equipment generates, uses and can radiate radio frequency energy and,

if not installed and used in accordance with the instructions, may cause harmful interference to radio communications. However, there is no guarantee that interference will not occur in a particular installation. If this equipment does cause harmful interference to radio or television reception, which can be determined by turning the equipment off and on, the user is encouraged to try to correct the interference by one or more of the following measures: Reorient or relocate the receiving antenna. Increase the separation between the equipment and receiver. Connect the equipment into an outlet on a circuit different from that to which the receiver is connected. Consult the dealer or an experienced radio/TV technician for help.

NOTE: FCC Radiation Exposure Statement: This equipment complies with FCC radiation exposure limits set forth for an uncontrolled environment. This transmitter must not be co-located or operating in conjunction with any other antenna or transmitter. NOTE: Changes or modifications not expressly approved by Nokia could void the user's authority to operate the equipment.