

Confidential
jedrocha
David Zhang; PCO reviewer
2014-12-01 10:38
© 2014 Microsoft

Confidential
jedrocha
David Zhang; PCO reviewer
2014-12-01 10:38
© 2014 Microsoft

Confidential
jedrocha
David Zhang; PCO reviewer
2014-12-01 10:38
© 2014 Microsoft

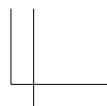

Quick Guide
Microsoft Lumia xxx
Microsoft Lumia xxx



[ERROR: book part number not defined] 1068
1 EN RM-1070

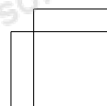
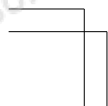

Confidential
jedrocha
David Zhang; PCO reviewer
2014-12-01 10:38
© 2014 Microsoft

Confidential
jedrocha
David Zhang; PCO reviewer
2014-12-01 10:38
© 2014 Microsoft

Confidential
jedrocha
David Zhang; PCO reviewer
2014-12-01 10:38
© 2014 Microsoft

Confidential
jedrocha
David Zhang; PCO reviewer
2014-12-01 10:38
© 2014 Microsoft

Confidential
jedrocha
David Zhang; PCO reviewer
2014-12-01 10:38
© 2014 Microsoft

Confidential
jedrocha
David Zhang; PCO reviewer
2014-12-01 10:38
© 2014 Microsoft

Confidential
jedrocha
David Zhang; PCO reviewer
2014-12-01 10:38
© 2014 Microsoft

Confidential
jedrocha
David Zhang; PCO reviewer
2014-12-01 10:38
© 2014 Microsoft

Confidential
jedrocha
David Zhang; PCO reviewer
2014-12-01 10:38
© 2014 Microsoft

Confidential
jedrocha
David Zhang; PCO reviewer
2014-12-01 10:38
© 2014 Microsoft

Confidential
jedrocha
David Zhang; PCO reviewer
2014-12-01 10:38
© 2014 Microsoft

Confidential
jedrocha
David Zhang; PCO reviewer
2014-12-01 10:38
© 2014 Microsoft

Confidential
jedrocha
David Zhang; PCO reviewer
2014-12-01 10:38
© 2014 Microsoft

Confidential
jedrocha
David Zhang; PCO reviewer
2014-12-01 10:38
© 2014 Microsoft

Confidential
jedrocha
David Zhang; PCO reviewer
2014-12-01 10:38
© 2014 Microsoft

Confidential
jedrocha
David Zhang; PCO reviewer
2014-12-01 10:38
© 2014 Microsoft

Confidential
jedrocha
David Zhang; PCO reviewer
2014-12-01 10:38
© 2014 Microsoft

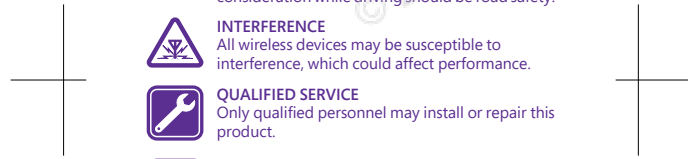
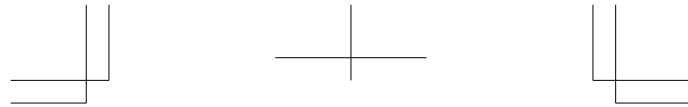

For your safety

We invite you to read the instructions on this guide before using the device.



SWITCH OFF IN RESTRICTED AREAS

Switch the device off when mobile phone use is not allowed or when it may cause interference or danger, for example, in aircraft, in hospitals or near medical equipment, fuel, chemicals, or blasting areas. Obey all instructions in restricted areas.



ROAD SAFETY COMES FIRST

Obey all local laws. Always keep your hands free to operate the vehicle while driving. Your first consideration while driving should be road safety.



INTERFERENCE

All wireless devices may be susceptible to interference, which could affect performance.



QUALIFIED SERVICE

Only qualified personnel may install or repair this product.



BATTERIES, CHARGERS, AND OTHER ACCESSORIES

Use only batteries, chargers, and other accessories approved by Microsoft Mobile for use with this device. Third-party chargers that comply with the IEC/EN 62684 standard, and that can connect to your device micro USB connector, may be compatible. Do not connect incompatible products.



KEEP YOUR DEVICE DRY

Your device is not water-resistant. Keep it dry.

Confidential
jedrocha
David Zhang; PCO reviewer
2014-12-01 10:38
© 2014 Microsoft

Confidential
jedrocha
David Zhang; PCO reviewer
2014-12-01 10:38
© 2014 Microsoft

Confidential
jedrocha
David Zhang; PCO reviewer
2014-12-01 10:38
© 2014 Microsoft



Confidential
jedrocha
David Zhang; PCO reviewer
2014-12-01 10:38
© 2014 Microsoft



GLASS PARTS

The device screen is made of glass. This glass can break if the device is dropped on a hard surface or receives a substantial impact. If the glass breaks, do not touch the glass parts of the device or attempt to remove the broken glass from the device. Stop using the device until the glass is replaced by qualified service personnel.



PROTECT YOUR HEARING

To prevent possible hearing damage, do not listen at high volume levels for long periods. Exercise caution when holding your device near your ear while the loudspeaker is in use.



SAR

This device meets RF exposure guidelines when used either in the normal use position against the ear or when positioned at least 1.5 centimetres (5/8 inch) away from the body. The specific maximum SAR values can be found in the Certification Information (SAR) section of this user guide. For more info, go to www.sar-tick.com.

When a carry case, belt clip or other form of device holder is used for body-worn operation, it should not contain metal and should provide at least the above-stated separation distance from the body. Note that mobile devices may be transmitting even if you are not making a voice call.

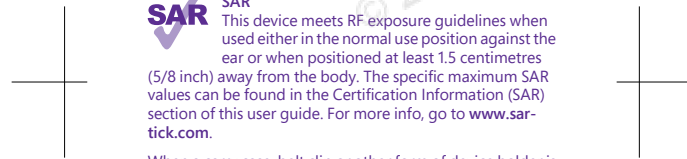

Confidential
jedrocha
David Zhang; PCO reviewer
2014-12-01 10:38
© 2014 Microsoft

Confidential
jedrocha
David Zhang; PCO reviewer
2014-12-01 10:38
© 2014 Microsoft

Confidential
jedrocha
David Zhang; PCO reviewer
2014-12-01 10:38
© 2014 Microsoft

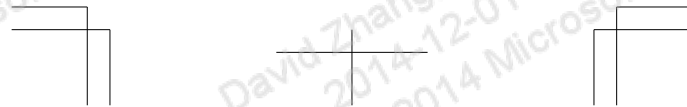

Confidential
jedrocha
David Zhang; PCO reviewer
2014-12-01 10:38
© 2014 Microsoft

Confidential
jedrocha
David Zhang; PCO reviewer
2014-12-01 10:38
© 2014 Microsoft

Confidential
jedrocha
David Zhang; PCO reviewer
2014-12-01 10:38
© 2014 Microsoft

Confidential
jedrocha
David Zhang; PCO reviewer
2014-12-01 10:38
© 2014 Microsoft

Confidential
jedrocha
David Zhang; PCO reviewer
2014-12-01 10:38
© 2014 Microsoft

Confidential
jedrocha
David Zhang; PCO reviewer
2014-12-01 10:38
© 2014 Microsoft



Confidential
jedrocha
David Zhang; PCO reviewer
2014-12-01 10:38
© 2014 Microsoft

Keys and parts

- 1 Earpiece
- 2 Audio connector (3,5 mm)
- 3 Front camera
- 4 Volume keys
- 5 Power/Lock key
- 6 Search key
- 7 Microphone
- 8 Micro-USB connector
- 9 Back key
- 10 Start key
- 11 Touch screen
- 12 Back camera
- 13 Antenna area
- 14 Loudspeaker

Some of the accessories mentioned in this user guide, such as charger, headset, or data cable, may be sold separately.

Avoid touching the antenna area while the antenna is in use. Contact with antennas affects the communication quality and may reduce battery life due to higher power level during operation.

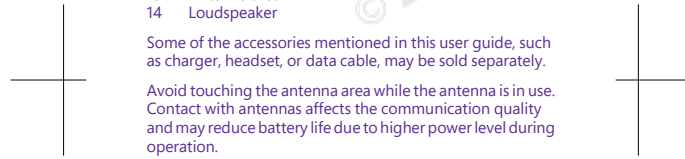

Confidential
jedrocha
David Zhang; PCO reviewer
2014-12-01 10:38
© 2014 Microsoft

Confidential
jedrocha
David Zhang; PCO reviewer
2014-12-01 10:38
© 2014 Microsoft

4

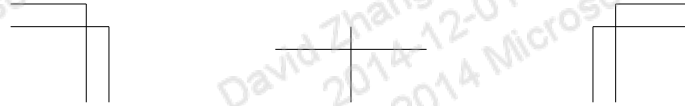

Confidential
jedrocha
David Zhang; PCO reviewer
2014-12-01 10:38
© 2014 Microsoft

Confidential
jedrocha
David Zhang; PCO reviewer
2014-12-01 10:38
© 2014 Microsoft

Confidential
jedrocha
David Zhang; PCO reviewer
2014-12-01 10:38
© 2014 Microsoft

Confidential
jedrocha
David Zhang; PCO reviewer
2014-12-01 10:38
© 2014 Microsoft

Confidential
jedrocha
David Zhang; PCO reviewer
2014-12-01 10:38
© 2014 Microsoft

Confidential
jedrocha
David Zhang; PCO reviewer
2014-12-01 10:38
© 2014 Microsoft

Confidential
jedrocha
David Zhang; PCO reviewer
2014-12-01 10:38
© 2014 Microsoft

Confidential
jedrocha
David Zhang; PCO reviewer
2014-12-01 10:38
© 2014 Microsoft

Confidential
jedrocha
David Zhang; PCO reviewer
2014-12-01 10:38
© 2014 Microsoft

Confidential
jedrocha
David Zhang; PCO reviewer
2014-12-01 10:38
© 2014 Microsoft

Confidential
jedrocha
David Zhang; PCO reviewer
2014-12-01 10:38
© 2014 Microsoft

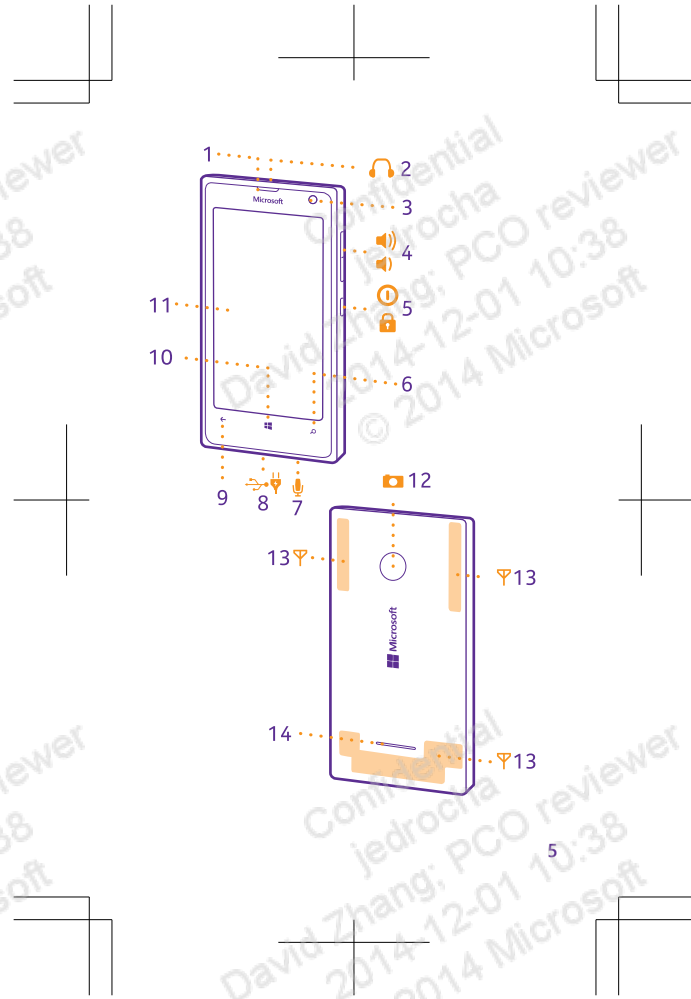

Confidential
jedrocha
David Zhang; PCO reviewer
2014-12-01 10:38
© 2014 Microsoft

Confidential
jedrocha
David Zhang; PCO reviewer
2014-12-01 10:38
© 2014 Microsoft

Confidential
jedrocha
David Zhang; PCO reviewer
2014-12-01 10:38
© 2014 Microsoft

Confidential
jedrocha
David Zhang; PCO reviewer
2014-12-01 10:38
© 2014 Microsoft

Confidential
jedrocha
David Zhang; PCO reviewer
2014-12-01 10:38
© 2014 Microsoft

Confidential
jedrocha
David Zhang; PCO reviewer
2014-12-01 10:38
© 2014 Microsoft

Confidential
jedrocha
David Zhang; PCO reviewer
2014-12-01 10:38
© 2014 Microsoft

Confidential
jedrocha
David Zhang; PCO reviewer
2014-12-01 10:38
© 2014 Microsoft

Confidential
jedrocha
David Zhang; PCO reviewer
2014-12-01 10:38
© 2014 Microsoft

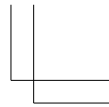
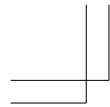

Confidential
jedrocha
David Zhang; PCO reviewer
2014-12-01 10:38
© 2014 Microsoft

Get started

Before you start using your phone, remove the back cover and battery to insert the micro-SIM cards (also known as mini-UICC cards).

Remove the back cover and battery

Make sure the phone is switched off.

1. Hold your phone by the top corners in one hand, and with the thumb of your other hand, press the back cover, and remove it. Do not use any sharp tools, as they may damage the phone.
2. If the battery is in, lift it out.

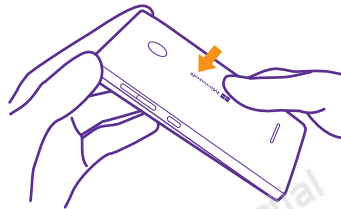

6

Confidential
jedrocha
David Zhang; PCO reviewer
2014-12-01 10:38
© 2014 Microsoft

Confidential
jedrocha
David Zhang; PCO reviewer
2014-12-01 10:38
© 2014 Microsoft

Confidential
jedrocha
David Zhang; PCO reviewer
2014-12-01 10:38
© 2014 Microsoft

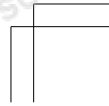
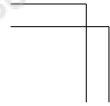

Confidential
jedrocha
David Zhang; PCO reviewer
2014-12-01 10:38
© 2014 Microsoft

Confidential
jedrocha
David Zhang; PCO reviewer
2014-12-01 10:38
© 2014 Microsoft

Confidential
jedrocha
David Zhang; PCO reviewer
2014-12-01 10:38
© 2014 Microsoft

Confidential
jedrocha
David Zhang; PCO reviewer
2014-12-01 10:38
© 2014 Microsoft

Confidential
jedrocha
David Zhang; PCO reviewer
2014-12-01 10:38
© 2014 Microsoft

Confidential
jedrocha
David Zhang; PCO reviewer
2014-12-01 10:38
© 2014 Microsoft

Confidential
jedrocha
David Zhang; PCO reviewer
2014-12-01 10:38
© 2014 Microsoft

Insert the SIM and memory card

1. Open the SIM holder, and put the micro-SIM in place with the metal contact area down. Close the holder.
2. For RM-1068: If you have a second SIM card, open the SIM2 holder, and put the SIM in place with the metal contact area down. Close the holder.

You can use 2G or 3G SIMs in both SIM1 and SIM2 holders. While 3G network is active on one SIM, the other supports only 2G network.

3. If you have a memory card, slide the card into the memory card slot.

It is recommended that you use a fast microSD card from a well-known manufacturer.

Important: Your device uses a micro-SIM card, also known as a mini-UICC SIM card. Use only original micro-SIM cards. Use of incompatible SIM cards, or use of SIM card adapters,

Confidential
jedrocha
David Zhang; PCO reviewer
2014-12-01 10:38
© 2014 Microsoft

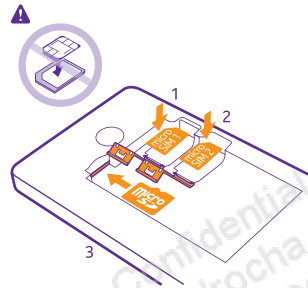

Confidential
jedrocha
David Zhang; PCO reviewer
2014-12-01 10:38
© 2014 Microsoft

Confidential
jedrocha
David Zhang; PCO reviewer
2014-12-01 10:38
© 2014 Microsoft

Confidential
jedrocha
David Zhang; PCO reviewer
2014-12-01 10:38
© 2014 Microsoft

Confidential
jedrocha
David Zhang; PCO reviewer
2014-12-01 10:38
© 2014 Microsoft

Confidential
jedrocha
David Zhang; PCO reviewer
2014-12-01 10:38
© 2014 Microsoft

Confidential
jedrocha
David Zhang; PCO reviewer
2014-12-01 10:38
© 2014 Microsoft

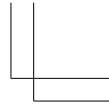
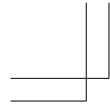

may damage the card or the device, and may corrupt data stored on the card.

Confidential
jedrocha
David Zhang; PCO reviewer
2014-12-01 10:38
© 2014 Microsoft

Confidential
jedrocha
David Zhang; PCO reviewer
2014-12-01 10:38
© 2014 Microsoft

Confidential
jedrocha
David Zhang; PCO reviewer
2014-12-01 10:38
© 2014 Microsoft



Confidential
jedrocha
David Zhang; PCO reviewer
2014-12-01 10:38
© 2014 Microsoft

Confidential
jedrocha
David Zhang; PCO reviewer
2014-12-01 10:38
© 2014 Microsoft

Confidential
jedrocha
David Zhang; PCO reviewer
2014-12-01 10:38
© 2014 Microsoft

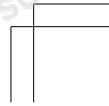
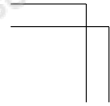

Confidential
jedrocha
David Zhang; PCO reviewer
2014-12-01 10:38
© 2014 Microsoft

Confidential
jedrocha
David Zhang; PCO reviewer
2014-12-01 10:38
© 2014 Microsoft

Confidential
jedrocha
David Zhang; PCO reviewer
2014-12-01 10:38
© 2014 Microsoft

Confidential
jedrocha
David Zhang; PCO reviewer
2014-12-01 10:38
© 2014 Microsoft

Confidential
jedrocha
David Zhang; PCO reviewer
2014-12-01 10:38
© 2014 Microsoft

Confidential
jedrocha
David Zhang; PCO reviewer
2014-12-01 10:38
© 2014 Microsoft

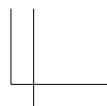

Get started

Replace the battery and back cover

1. Line up the battery contacts, and put the battery in.
2. Press the bottom edge of the back cover against the bottom edge of your phone, and snap the cover into place.
3. To switch your phone on, press and hold the power key.

Charge the battery

Plug a compatible charger into a wall outlet, and connect the micro-USB end to your phone. You can also charge your phone from a computer with a USB cable.

If the battery is completely discharged, it may take up to 20 minutes before the charging indicator is displayed.

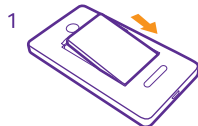

Confidential
jedrocha
David Zhang; PCO reviewer
2014-12-01 10:38
© 2014 Microsoft

Confidential
jedrocha
David Zhang; PCO reviewer
2014-12-01 10:38
© 2014 Microsoft

Confidential
jedrocha
David Zhang; PCO reviewer
2014-12-01 10:38
© 2014 Microsoft

Confidential
jedrocha
David Zhang; PCO reviewer
2014-12-01 10:38
© 2014 Microsoft

Confidential
jedrocha
David Zhang; PCO reviewer
2014-12-01 10:38
© 2014 Microsoft

Confidential
jedrocha
David Zhang; PCO reviewer
2014-12-01 10:38
© 2014 Microsoft

Confidential
jedrocha
David Zhang; PCO reviewer
2014-12-01 10:38
© 2014 Microsoft

Confidential
jedrocha
David Zhang; PCO reviewer
2014-12-01 10:38
© 2014 Microsoft

Confidential
jedrocha
David Zhang; PCO reviewer
2014-12-01 10:38
© 2014 Microsoft

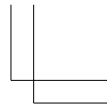
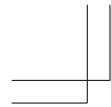

Confidential
jedrocha
David Zhang; PCO reviewer
2014-12-01 10:38
© 2014 Microsoft

Set up your phone

1. To switch your phone on, press and hold the power key, and follow the instructions shown on your phone.
2. When asked, create your Microsoft account if you don't have one already, or sign in with your existing Xbox, Hotmail, or Outlook username and password.

You need a Microsoft account to back up and restore your phone, to buy, install, and update apps, and to access some Microsoft services, such as OneDrive.

Allow some minutes while your phone installs all its features.

Tip: If your screen switches off, press the power key, and drag the lock screen up.

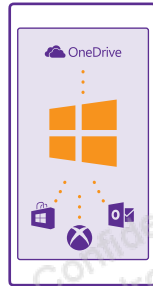

10

Confidential
jedrocha
David Zhang; PCO reviewer
2014-12-01 10:38
© 2014 Microsoft

Confidential
jedrocha
David Zhang; PCO reviewer
2014-12-01 10:38
© 2014 Microsoft

Confidential
jedrocha
David Zhang; PCO reviewer
2014-12-01 10:38
© 2014 Microsoft

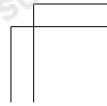
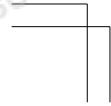

Confidential
jedrocha
David Zhang; PCO reviewer
2014-12-01 10:38
© 2014 Microsoft

Confidential
jedrocha
David Zhang; PCO reviewer
2014-12-01 10:38
© 2014 Microsoft

Confidential
jedrocha
David Zhang; PCO reviewer
2014-12-01 10:38
© 2014 Microsoft

Confidential
jedrocha
David Zhang; PCO reviewer
2014-12-01 10:38
© 2014 Microsoft

Confidential
jedrocha
David Zhang; PCO reviewer
2014-12-01 10:38
© 2014 Microsoft



Confidential
jedrocha
David Zhang; PCO reviewer
2014-12-01 10:38
© 2014 Microsoft

Confidential
jedrocha
David Zhang; PCO reviewer
2014-12-01 10:38
© 2014 Microsoft

Explore your tiles and apps

The start screen is the main view of your phone. Pin shortcuts to apps, contacts, browser bookmarks, and more, and arrange and resize the tiles. Some tiles may show you notifications and updates.

The apps menu is the home to all your apps. To go to the apps menu from the start screen, swipe left. To go back, swipe right.

Tip: To go back to the start screen from any view, tap . To switch between open apps, tap and hold  and choose the app you want. To close an app, tap .

To see more options, such as settings, in an app, tap  at the bottom right corner.

Confidential
jedrocha
David Zhang; PCO reviewer
2014-12-01 10:38
© 2014 Microsoft

Confidential
jedrocha
David Zhang; PCO reviewer
2014-12-01 10:38
© 2014 Microsoft

Confidential
jedrocha
David Zhang; PCO reviewer
2014-12-01 10:38
© 2014 Microsoft

Confidential
jedrocha
David Zhang; PCO reviewer
2014-12-01 10:38
© 2014 Microsoft

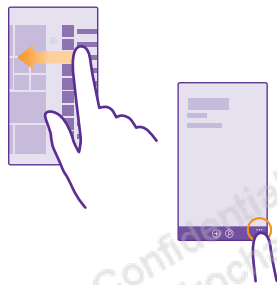

Confidential
jedrocha
David Zhang; PCO reviewer
2014-12-01 10:38
© 2014 Microsoft

Confidential
jedrocha
David Zhang; PCO reviewer
2014-12-01 10:38
© 2014 Microsoft

Confidential
jedrocha
David Zhang; PCO reviewer
2014-12-01 10:38
© 2014 Microsoft

Confidential
jedrocha
David Zhang; PCO reviewer
2014-12-01 10:38
© 2014 Microsoft

Confidential
jedrocha
David Zhang; PCO reviewer
2014-12-01 10:38
© 2014 Microsoft

Confidential
jedrocha
David Zhang; PCO reviewer
2014-12-01 10:38
© 2014 Microsoft

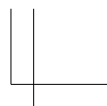

Confidential
jedrocha
David Zhang; PCO reviewer
2014-12-01 10:38
© 2014 Microsoft

Navigate by touch

To use your phone, simply swipe, tap, or tap and hold the screen.

Swipe

Place your finger on the screen, and slide your finger in the direction you want.

For example, to open the action centre, place a finger at the top of the screen, and slide it down.

Zoom in or out

Place 2 fingers on an item, such as a photo or a web page, and slide your fingers apart or together.

Tap and hold to open a menu

Place your finger on an item, until the menu opens.

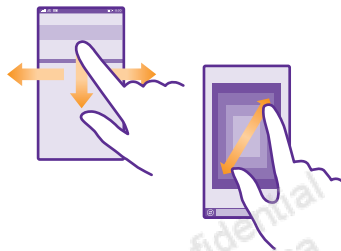

Confidential
jedrocha
David Zhang; PCO reviewer
2014-12-01 10:38
© 2014 Microsoft

Confidential
jedrocha
David Zhang; PCO reviewer
2014-12-01 10:38
© 2014 Microsoft

Confidential
jedrocha
David Zhang; PCO reviewer
2014-12-01 10:38
© 2014 Microsoft

Confidential
jedrocha
David Zhang; PCO reviewer
2014-12-01 10:38
© 2014 Microsoft

Confidential
jedrocha
David Zhang; PCO reviewer
2014-12-01 10:38
© 2014 Microsoft

Confidential
jedrocha
David Zhang; PCO reviewer
2014-12-01 10:38
© 2014 Microsoft

Confidential
jedrocha
David Zhang; PCO reviewer
2014-12-01 10:38
© 2014 Microsoft

Confidential
jedrocha
David Zhang; PCO reviewer
2014-12-01 10:38
© 2014 Microsoft

Confidential
jedrocha
David Zhang; PCO reviewer
2014-12-01 10:38
© 2014 Microsoft

Confidential
jedrocha
David Zhang; PCO reviewer
2014-12-01 10:38
© 2014 Microsoft

Confidential
jedrocha
David Zhang; PCO reviewer
2014-12-01 10:38
© 2014 Microsoft

Confidential
jedrocha
David Zhang; PCO reviewer
2014-12-01 10:38
© 2014 Microsoft

Confidential
jedrocha
David Zhang; PCO reviewer
2014-12-01 10:38
© 2014 Microsoft

Confidential
jedrocha
David Zhang; PCO reviewer
2014-12-01 10:38
© 2014 Microsoft

Confidential
jedrocha
David Zhang; PCO reviewer
2014-12-01 10:38
© 2014 Microsoft

Confidential
jedrocha
David Zhang; PCO reviewer
2014-12-01 10:38
© 2014 Microsoft

Confidential
jedrocha
David Zhang; PCO reviewer
2014-12-01 10:38
© 2014 Microsoft

Confidential
jedrocha
David Zhang; PCO reviewer
2014-12-01 10:38
© 2014 Microsoft

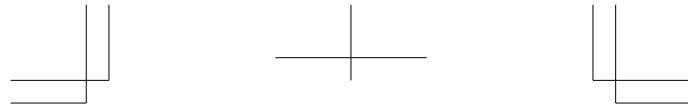

Transfer content from your old phone

You can transfer content from your old phone in several ways.

To transfer your contacts, text messages, pictures, and videos, use the Transfer my Data app. Your old phone must support Bluetooth. Not all phones or content may be compatible with the transfer.

To transfer other content, such as music, see the section for new Lumia users in the [Lumia Help + Tips](#) app, or go to www.microsoft.com/mobile/switch-easy.

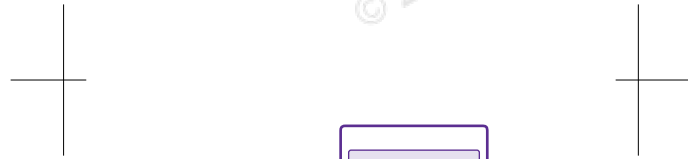

Confidential
jedrocha
David Zhang; PCO reviewer
2014-12-01 10:38
© 2014 Microsoft

Confidential
jedrocha
David Zhang; PCO reviewer
2014-12-01 10:38
© 2014 Microsoft

Confidential
jedrocha
David Zhang; PCO reviewer
2014-12-01 10:38
© 2014 Microsoft

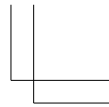
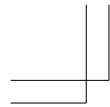

Confidential
jedrocha
David Zhang; PCO reviewer
2014-12-01 10:38
© 2014 Microsoft

Help and tips

There's a user guide in your phone – it's always with you, available when needed. Check out videos, find answers to your questions, and get helpful tips. On the start screen, swipe left, and tap  Lumia Help + Tips. If you're new to Lumia, check out the section for new users. Make sure to keep the Lumia Help + Tips app up to date.

For the online user guide, even more info, and troubleshooting help, go to www.microsoft.com/mobile/support/.

If your phone doesn't respond

To restart the phone without losing your data and settings, press and hold the volume down key and power key at the same time for about 10 seconds. The phone vibrates and restarts.

You can also remove and replace the battery, and switch the phone on.



Confidential
jedrocha
David Zhang; PCO reviewer
2014-12-01 10:38
© 2014 Microsoft

Confidential
jedrocha
David Zhang; PCO reviewer
2014-12-01 10:38
© 2014 Microsoft

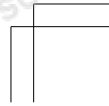
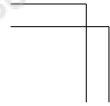

Confidential
jedrocha
David Zhang; PCO reviewer
2014-12-01 10:38
© 2014 Microsoft

Confidential
jedrocha
David Zhang; PCO reviewer
2014-12-01 10:38
© 2014 Microsoft

Confidential
jedrocha
David Zhang; PCO reviewer
2014-12-01 10:38
© 2014 Microsoft

Confidential
jedrocha
David Zhang; PCO reviewer
2014-12-01 10:38
© 2014 Microsoft

Confidential
jedrocha
David Zhang; PCO reviewer
2014-12-01 10:38
© 2014 Microsoft

Confidential
jedrocha
David Zhang; PCO reviewer
2014-12-01 10:38
© 2014 Microsoft

Confidential
jedrocha
David Zhang; PCO reviewer
2014-12-01 10:38
© 2014 Microsoft

Confidential
jedrocha
David Zhang; PCO reviewer
2014-12-01 10:38
© 2014 Microsoft

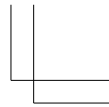
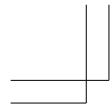

Feature-specific information

Using services or downloading content, including free items, may cause the transfer of large amounts of data, which may result in data costs.

Important: Your device uses a micro-SIM card, also known as a mini-UICC SIM card. Use only original micro-SIM cards. Use of incompatible SIM cards, or use of SIM card adapters, may damage the card or the device, and may corrupt data stored on the card. Use only compatible memory cards approved for use with this device. Incompatible cards may damage the card and the device and corrupt data stored on the card.



Characters with accents, other marks, or some language options, take more space, and limit the number of characters that can be sent in a single message.

The list of countries and territories included in the time zone settings does not imply sovereignty.

To access the Windows Phone software license terms, select **Settings > about**. Please read the terms. Note that by using the software, you accept the terms. If you do not accept the terms, do not use the device or software. Instead contact Microsoft Mobile or the party from which you purchased the device to determine its return policy.

Find your model number and serial number (IMEI)

If you need to contact your care point or your service provider, you may need info such as the model number and the serial number (IMEI). To see the info, tap **Settings > about**. You can also find the info on your phone label, which is located under the battery.

Product and safety info

Network services and costs

You can only use your device on the GSM 850, 900, 1800, 1900 MHz networks; WCDMA 850, 900, 1900, 2100 MHz networks. You need a subscription with a service provider.

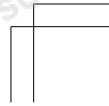
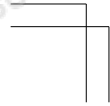

Confidential
jedrocha
David Zhang; PCO reviewer
2014-12-01 10:38
© 2014 Microsoft

Confidential
jedrocha
David Zhang; PCO reviewer
2014-12-01 10:38
© 2014 Microsoft

Confidential
jedrocha
David Zhang; PCO reviewer
2014-12-01 10:38
© 2014 Microsoft

Confidential
jedrocha
David Zhang; PCO reviewer
2014-12-01 10:38
© 2014 Microsoft

Confidential
jedrocha
David Zhang; PCO reviewer
2014-12-01 10:38
© 2014 Microsoft

Confidential
jedrocha
David Zhang; PCO reviewer
2014-12-01 10:38
© 2014 Microsoft

Confidential
jedrocha
David Zhang; PCO reviewer
2014-12-01 10:38
© 2014 Microsoft

Confidential
jedrocha
David Zhang; PCO reviewer
2014-12-01 10:38
© 2014 Microsoft

Confidential
jedrocha
David Zhang; PCO reviewer
2014-12-01 10:38
© 2014 Microsoft

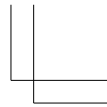
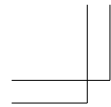

Using some features and downloading content require a network connection and may result in data costs. You may also need to subscribe to some features.

Make an emergency call

Important: Connections in all conditions cannot be guaranteed. Never rely solely on any wireless phone for essential communications like medical emergencies.

Before making the call:

- Switch the phone on.
 - If the phone screen and keys are locked, unlock them.
 - Move to a place with adequate signal strength.
1. Press **[*]** and tap **[0]** > **[9]**.
 2. Type in the official emergency number for your present location. Emergency call numbers vary by location.
 3. Tap call.
 4. Give the necessary info as accurately as possible. Do not end the call until given permission to do so.
- You may also need to do the following:
- Put a SIM card in the phone.
 - If your phone asks for a PIN code, tap **emergency call**.
 - Switch the call restrictions off in your phone, such as call barring, fixed dialling, or closed user group.
 - When you switch your phone on for the first time, you are asked to create your Microsoft account and set up your phone. To make an emergency call during the account and phone setup, tap **emergency call**.
 - If the mobile network is not available, you may also try making an internet call, if you can access the internet.

Take care of your device

See the in-device user guide for important instructions on how to take care of your device.
Do not drop, knock, or shake the device or the battery. Rough handling can break them.

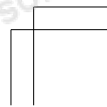
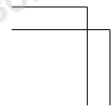

Confidential
jedrocha
David Zhang; PCO reviewer
2014-12-01 10:38
© 2014 Microsoft

Confidential
jedrocha
David Zhang; PCO reviewer
2014-12-01 10:38
© 2014 Microsoft

Confidential
jedrocha
David Zhang; PCO reviewer
2014-12-01 10:38
© 2014 Microsoft

Confidential
jedrocha
David Zhang; PCO reviewer
2014-12-01 10:38
© 2014 Microsoft

Confidential
jedrocha
David Zhang; PCO reviewer
2014-12-01 10:38
© 2014 Microsoft

Confidential
jedrocha
David Zhang; PCO reviewer
2014-12-01 10:38
© 2014 Microsoft

Confidential
jedrocha
David Zhang; PCO reviewer
2014-12-01 10:38
© 2014 Microsoft

Confidential
jedrocha
David Zhang; PCO reviewer
2014-12-01 10:38
© 2014 Microsoft

Confidential
jedrocha
David Zhang; PCO reviewer
2014-12-01 10:38
© 2014 Microsoft



Recycle



When this device has reached the end of its working life, all of its materials can be recovered as materials and energy. For info on how to recycle your old products and where to find collection sites, go to www.microsoft.com/mobile/recycle, or call the Contact Center.

Recycle packaging and user guides at your local recycling scheme. When you cooperate and deliver all these materials to one of the available collection sites, you contribute in helping the environment and help to ensure the health of future generations.

All electrical and electronic products and batteries may contain recyclable metals and other potentially hazardous substances and must be taken to their respective collection sites at the end of their working life. Under no circumstances should you break open a battery or other related materials. Do not dispose of these products as unsorted municipal waste, as this may cause contamination of the environment or risks to human health. All Microsoft Mobile products are in compliance to the applicable industry international production standards and to all requirements defined by the competent government agencies. For more info on the environmental attributes of your device, see www.microsoft.com/mobile/ecoprofile (in English).

About Digital Rights Management

When using this device, obey all laws and respect local customs, privacy and legitimate rights of others, including copyrights. Copyright protection may prevent you from copying, modifying, or transferring photos, music, and other content.

Battery and charger info

Use your device only with an original BV-5J rechargeable battery. Charge your device with AC-18 charger. Charger plug type may vary. Third-party chargers that comply with the IEC/EN 62684 standard, and that can connect to your device micro USB connector, may be compatible. Microsoft Mobile may make additional battery or charger models available for this device.

Confidential
jedrocha
David Zhang; PCO reviewer
2014-12-01 10:38
© 2014 Microsoft

Confidential
jedrocha
David Zhang; PCO reviewer
2014-12-01 10:38
© 2014 Microsoft

Confidential
jedrocha
David Zhang; PCO reviewer
2014-12-01 10:38
© 2014 Microsoft

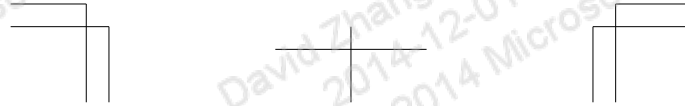

Confidential
jedrocha
David Zhang; PCO reviewer
2014-12-01 10:38
© 2014 Microsoft

Confidential
jedrocha
David Zhang; PCO reviewer
2014-12-01 10:38
© 2014 Microsoft

Confidential
jedrocha
David Zhang; PCO reviewer
2014-12-01 10:38
© 2014 Microsoft

Confidential
jedrocha
David Zhang; PCO reviewer
2014-12-01 10:38
© 2014 Microsoft

Confidential
jedrocha
David Zhang; PCO reviewer
2014-12-01 10:38
© 2014 Microsoft

Confidential
jedrocha
David Zhang; PCO reviewer
2014-12-01 10:38
© 2014 Microsoft



Confidential
jedrocha
David Zhang; PCO reviewer
2014-12-01 10:38
© 2014 Microsoft

Battery and charger safety

Always switch the device off and unplug the charger before removing the battery. To unplug a charger or an accessory, hold and pull the plug, not the cord.

When your charger is not in use, unplug it. If left unused, a fully charged battery will lose its charge over time.

Always keep the battery between 15°C and 25°C (59°F and 77°F) for optimal performance. Extreme temperatures reduce the capacity and lifetime of the battery. A device with a hot or cold battery may not work temporarily.

Accidental short-circuiting can happen when a metallic object touches the metal strips on the battery. This may damage the battery or the other object.

Do not dispose of batteries in a fire as they may explode. Obey local regulations. Recycle when possible. Do not dispose as household waste. Do not dismantle, cut, crush, bend, puncture, or otherwise damage the battery in any way. If a battery leaks, do not let liquid touch skin or eyes. If this happens, immediately flush the affected areas with water, or seek medical help. Do not modify, attempt to insert foreign objects into the battery, or immerse or expose it to water or other liquids. Batteries may explode if damaged.

Use the battery and charger for their intended purposes only. Improper use, or use of unapproved or incompatible batteries or chargers may present a risk of fire, explosion, or other hazard, and may invalidate any approval or warranty. If you believe the battery or charger is damaged, take it to a service centre before continuing to use it. Never use a damaged battery or charger. Only use the charger indoors. Do not charge your device during a lightning storm.

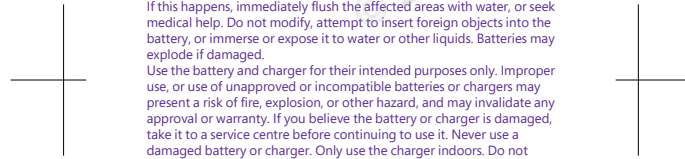

Small children

Your device and its accessories are not toys. They may contain small parts. Keep them out of the reach of small children.

Medical devices

Operation of radio transmitting equipment, including wireless phones, may interfere with inadequately shielded medical devices' function. Consult a physician or the medical device's manufacturer to determine if it is adequately shielded from external radio energy.



Confidential
jedrocha
David Zhang; PCO reviewer
2014-12-01 10:38
© 2014 Microsoft

Confidential
jedrocha
David Zhang; PCO reviewer
2014-12-01 10:38
© 2014 Microsoft

Confidential
jedrocha
David Zhang; PCO reviewer
2014-12-01 10:38
© 2014 Microsoft

Confidential
jedrocha
David Zhang; PCO reviewer
2014-12-01 10:38
© 2014 Microsoft

Confidential
jedrocha
David Zhang; PCO reviewer
2014-12-01 10:38
© 2014 Microsoft

Confidential
jedrocha
David Zhang; PCO reviewer
2014-12-01 10:38
© 2014 Microsoft

Confidential
jedrocha
David Zhang; PCO reviewer
2014-12-01 10:38
© 2014 Microsoft

Confidential
jedrocha
David Zhang; PCO reviewer
2014-12-01 10:38
© 2014 Microsoft

Confidential
jedrocha
David Zhang; PCO reviewer
2014-12-01 10:38
© 2014 Microsoft



Confidential
jedrocha
David Zhang; PCO reviewer
2014-12-01 10:38
© 2014 Microsoft

Implanted medical devices

To avoid potential interference, manufacturers of implanted medical devices recommend a minimum separation of 15.3 centimetres (6 inches) between a wireless device and the medical device. Persons who have such devices should:

- Always keep the wireless device more than 15.3 centimetres (6 inches) from the medical device.
 - Not carry the wireless device in a breast pocket.
 - Hold the wireless device to the ear opposite the medical device.
 - Switch the wireless device off if there is any reason to suspect that interference is taking place.
 - Follow the manufacturer directions for the implanted medical device.
- If you have any questions about using your wireless device with an implanted medical device, consult your health care provider.

Accessibility solutions

Microsoft Mobile is committed to making mobile phones easy to use for all individuals, including those with disabilities. For more information, visit aka.ms/phoneaccessibility (in English).

Hearing

Warning: When you use the headset, your ability to hear outside sounds may be affected. Do not use the headset where it can endanger your safety.
Some wireless devices may interfere with some hearing aids.

Nickel

The surface of this device is nickel-free.

Vehicles

Radio signals may affect improperly installed or inadequately shielded electronic systems in vehicles. For more info, check with the manufacturer of your vehicle or its equipment.
Only qualified personnel should install the device in a vehicle. Faulty installation may be dangerous and invalidate your warranty. Check regularly that all wireless device equipment in your vehicle is mounted and operating properly. Do not store or carry flammable or explosive materials in the same compartment as the device, its parts, or accessories. Do not place your device or accessories in the air bag deployment area.

Confidential
jedrocha
David Zhang; PCO reviewer
2014-12-01 10:38
© 2014 Microsoft

Confidential
jedrocha
David Zhang; PCO reviewer
2014-12-01 10:38
© 2014 Microsoft

Confidential
jedrocha
David Zhang; PCO reviewer
2014-12-01 10:38
© 2014 Microsoft

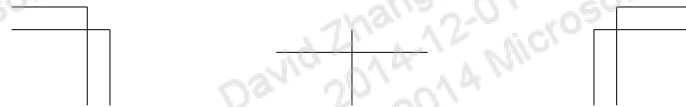

Confidential
jedrocha
David Zhang; PCO reviewer
2014-12-01 10:38
© 2014 Microsoft

Confidential
jedrocha
David Zhang; PCO reviewer
2014-12-01 10:38
© 2014 Microsoft

Confidential
jedrocha
David Zhang; PCO reviewer
2014-12-01 10:38
© 2014 Microsoft

Confidential
jedrocha
David Zhang; PCO reviewer
2014-12-01 10:38
© 2014 Microsoft

Confidential
jedrocha
David Zhang; PCO reviewer
2014-12-01 10:38
© 2014 Microsoft

Confidential
jedrocha
David Zhang; PCO reviewer
2014-12-01 10:38
© 2014 Microsoft

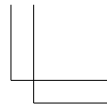
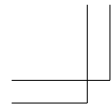

Confidential
jedrocha
David Zhang; PCO reviewer
2014-12-01 10:38
© 2014 Microsoft

Potentially explosive environments

Switch your device off in potentially explosive environments, such as near petrol pumps. Sparks may cause an explosion or fire resulting in injury or death. Note restrictions in areas with fuel; chemical plants; or where blasting operations are in progress. Areas with a potentially explosive environment may not be clearly marked. These usually are areas where you are advised to switch your engine off, below deck on boats, chemical transfer or storage facilities, and where the air contains chemicals or particles. Check with the manufacturers of vehicles using liquefied petroleum gas (such as propane or butane) if this device can be safely used in their vicinity.

Certification information (SAR)

This mobile device meets international guidelines for exposure to radio waves.

Your mobile device is a radio transmitter and receiver. It is designed not to exceed the limits for exposure to radio waves (radio frequency electromagnetic fields), recommended by international guidelines from the independent scientific organization ICNIRP. These guidelines incorporate substantial safety margins that are intended to assure the protection of all persons regardless of age and health. The exposure guidelines are based on the Specific Absorption Rate (SAR), which is an expression of the amount of radio frequency (RF) power deposited in the head or body when the device is transmitting. The ICNIRP SAR limit for mobile devices is 2.0 W/kg averaged over 10 grams of tissue.

SAR tests are carried out with the device in standard operating positions, transmitting at its highest certified power level, in all its frequency bands. The maximum recorded SAR values for this device are:

| | Maximum SAR value | Frequency bands used when Maximum SAR value was recorded |
|--|--------------------|--|
| When held against the head | 0.58 W/kg over 10g | WCDMA900+WLAN 2450 |
| When operated at a separation distance | 0.54 W/kg over 10g | WCDMA900+WLAN 2450 |

20

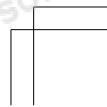
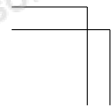

Confidential
jedrocha
David Zhang; PCO reviewer
2014-12-01 10:38
© 2014 Microsoft

Confidential
jedrocha
David Zhang; PCO reviewer
2014-12-01 10:38
© 2014 Microsoft

Confidential
jedrocha
David Zhang; PCO reviewer
2014-12-01 10:38
© 2014 Microsoft

Confidential
jedrocha
David Zhang; PCO reviewer
2014-12-01 10:38
© 2014 Microsoft

Confidential
jedrocha
David Zhang; PCO reviewer
2014-12-01 10:38
© 2014 Microsoft

Confidential
jedrocha
David Zhang; PCO reviewer
2014-12-01 10:38
© 2014 Microsoft

Confidential
jedrocha
David Zhang; PCO reviewer
2014-12-01 10:38
© 2014 Microsoft

Confidential
jedrocha
David Zhang; PCO reviewer
2014-12-01 10:38
© 2014 Microsoft

Confidential
jedrocha
David Zhang; PCO reviewer
2014-12-01 10:38
© 2014 Microsoft



of 1.5 centimetres
(5/8 inch) from the
body

Your mobile device is also designed to meet the United States Federal Communications Commission (FCC) guidelines. FCC ratings for your device and more information on SAR can be found at transition.fcc.gov/oet/rfsafety/sar.html.

This device meets RF exposure guidelines when used against the head or when positioned at least 1.5 centimetres (5/8 inch) away from the body. When a carry case, belt clip or other form of device holder is used for body-worn operation, it should not contain metal and should provide at least the above stated separation distance from the body.

To send data or messages, a good connection to the network is needed. Sending may be delayed until such a connection is available. Follow the separation distance instructions until the sending is finished.

During general use, the SAR values are usually well below the values stated above. This is because, for purposes of system efficiency and to minimise interference on the network, the operating power of your mobile is automatically decreased when full power is not needed for the call. The lower the power output, the lower the SAR value.

Device models may have different versions and more than one value. Component and design changes may occur over time and some changes could affect SAR values. The latest available SAR information for this and other Microsoft Mobile device models can be found at www.microsoft.com/mobile/sar.

The World Health Organization (WHO) has stated that current scientific information does not indicate the need for any special precautions when using mobile devices. If you are interested in reducing your exposure, they recommend you limit your usage or use a hands-free kit to keep the device away from your head and body. For more information and explanations and discussions on RF exposure, go to the WHO website at www.who.int/peh-emf/en.

Support messages

To help you take maximum advantage of your phone and services, you may receive messages from Microsoft Mobile. The messages may contain tips and tricks and support. To provide the service described above, your mobile phone number, the serial number of your phone, and some identifiers of the mobile subscription may be sent to Microsoft.

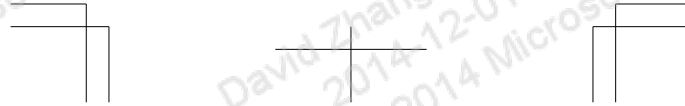

Confidential
jedrocha
David Zhang; PCO reviewer
2014-12-01 10:38
© 2014 Microsoft

Confidential
jedrocha
David Zhang; PCO reviewer
2014-12-01 10:38
© 2014 Microsoft

Confidential
jedrocha
David Zhang; PCO reviewer
2014-12-01 10:38
© 2014 Microsoft

Confidential
jedrocha
David Zhang; PCO reviewer
2014-12-01 10:38
© 2014 Microsoft

Confidential
jedrocha
David Zhang; PCO reviewer
2014-12-01 10:38
© 2014 Microsoft

Confidential
jedrocha
David Zhang; PCO reviewer
2014-12-01 10:38
© 2014 Microsoft

Confidential
jedrocha
David Zhang; PCO reviewer
2014-12-01 10:38
© 2014 Microsoft

Confidential
jedrocha
David Zhang; PCO reviewer
2014-12-01 10:38
© 2014 Microsoft

Confidential
jedrocha
David Zhang; PCO reviewer
2014-12-01 10:38
© 2014 Microsoft

Confidential
jedrocha
David Zhang; PCO reviewer
2014-12-01 10:38
© 2014 Microsoft

Confidential
jedrocha
David Zhang; PCO reviewer
2014-12-01 10:38
© 2014 Microsoft

Confidential
jedrocha
David Zhang; PCO reviewer
2014-12-01 10:38
© 2014 Microsoft

Confidential
jedrocha
David Zhang; PCO reviewer
2014-12-01 10:38
© 2014 Microsoft

Confidential
jedrocha
David Zhang; PCO reviewer
2014-12-01 10:38
© 2014 Microsoft

Confidential
jedrocha
David Zhang; PCO reviewer
2014-12-01 10:38
© 2014 Microsoft

Confidential
jedrocha
David Zhang; PCO reviewer
2014-12-01 10:38
© 2014 Microsoft

Confidential
jedrocha
David Zhang; PCO reviewer
2014-12-01 10:38
© 2014 Microsoft

Confidential
jedrocha
David Zhang; PCO reviewer
2014-12-01 10:38
© 2014 Microsoft

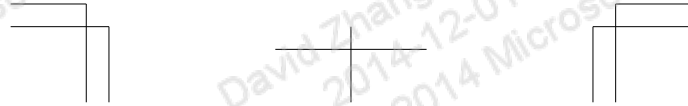
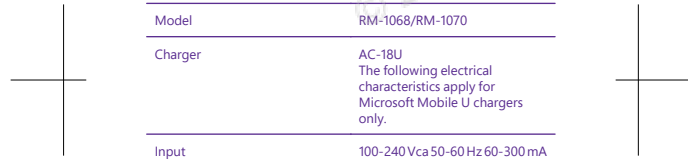
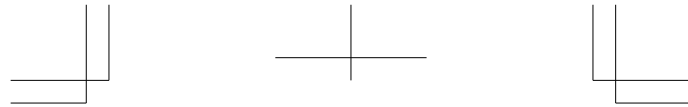

Mobile when you use the phone for the first time. This information may be used as specified in the privacy policy, available at www.microsoft.com/mobile.

Care

For questions regarding your plans, billing or network please contact your operator. For questions regarding your product and warranty, please visit the support pages for your country at www.microsoft.com/mobile/support/.

Electrical information of the device

This information applies only in Mexico.

| | |
|-------------------------------|--|
| Product | Mobile phone |
| Supplier | Microsoft Mobile |
| Model | RM-1068/RM-1070 |
| Charger | AC-18U The following electrical characteristics apply for Microsoft Mobile U chargers only. |
| Input | 100-240 Vca 50-60 Hz 60-300 mA |
| Output | 5.0 Vcc 550-900 mA |
| Rechargeable battery supplier | Microsoft Mobile |
| Phone power consumption | 3,7 Vcc |

Confidential
jedrocha
David Zhang; PCO reviewer
2014-12-01 10:38
© 2014 Microsoft

Confidential
jedrocha
David Zhang; PCO reviewer
2014-12-01 10:38
© 2014 Microsoft

Confidential
jedrocha
David Zhang; PCO reviewer
2014-12-01 10:38
© 2014 Microsoft

Confidential
jedrocha
David Zhang; PCO reviewer
2014-12-01 10:38
© 2014 Microsoft

Copyrights and other notices

Declaration of Conformity

CE 0168

Hereby, Microsoft Mobile Oy declares that this RM-1068 or RM-1070 product is in compliance with the essential requirements and other relevant provisions of Directive 1999/5/EC. A copy of the Declaration of Conformity can be found at www.microsoft.com/mobile/declaration-of-conformity (in English).

The availability of products, features, apps and services may vary by region. Microsoft Mobile may, in its sole discretion, change, correct or discontinue any of its services in whole or in part. For more info, contact your dealer or your service provider. This device may contain commodities, technology or software subject to export laws and regulations from the US and other countries. Diversion contrary to law is prohibited.

The contents of this document are provided "as is". Except as required by applicable law, no warranties of any kind, either express or implied, including, but not limited to, the implied warranties of merchantability and fitness for a particular purpose, are made in relation to the accuracy, reliability or contents of this document. Microsoft Mobile reserves the right to revise this document or withdraw it at any time without prior notice.

To the maximum extent permitted by applicable law, under no circumstances shall Microsoft Mobile or any of its licensors be responsible for any loss of data or income or any special, incidental, consequential or indirect damages howsoever caused.

Reproduction, transfer or distribution of part or all of the contents in this document in any form without the prior written permission of Microsoft Mobile is prohibited. Microsoft Mobile operates a policy of continuous development. Microsoft Mobile reserves the right to make changes and improvements to any of the products described in this document without prior notice.

Downloading of maps, games, music and videos and uploading of images and videos may involve transferring large amounts of data. Your service provider may charge for the data transmission. The availability of particular products, services and features may vary by region. Please check with your local dealer for further details and availability of language options.

Confidential
jedrocha
David Zhang; PCO reviewer
2014-12-01 10:38
© 2014 Microsoft

Confidential
jedrocha
David Zhang; PCO reviewer
2014-12-01 10:38
© 2014 Microsoft

Confidential
jedrocha
David Zhang; PCO reviewer
2014-12-01 10:38
© 2014 Microsoft

Confidential
jedrocha
David Zhang; PCO reviewer
2014-12-01 10:38
© 2014 Microsoft

Confidential
jedrocha
David Zhang; PCO reviewer
2014-12-01 10:38
© 2014 Microsoft

Confidential
jedrocha
David Zhang; PCO reviewer
2014-12-01 10:38
© 2014 Microsoft

Confidential
jedrocha
David Zhang; PCO reviewer
2014-12-01 10:38
© 2014 Microsoft

Confidential
jedrocha
David Zhang; PCO reviewer
2014-12-01 10:38
© 2014 Microsoft

Confidential
jedrocha
David Zhang; PCO reviewer
2014-12-01 10:38
© 2014 Microsoft

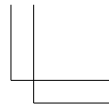
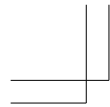

Confidential
jedrocha
David Zhang; PCO reviewer
2014-12-01 10:38
© 2014 Microsoft

FCC/MEXICO NOTICE

This FCC/MEXICO NOTICE is for RM-1068 or RM-1070.
This device complies with part 15 of the FCC rules. Operation is subject to the following two conditions: (1) This device may not cause harmful interference, and (2) this device must accept any interference received, including interference that may cause undesired operation. For more info, go to transition.fcc.gov/oet/rfsafety/rf-faqs.html. Any changes or modifications not expressly approved by Microsoft Mobile could void the user's authority to operate this equipment.

Note: This equipment has been tested and found to comply with the limits for a Class B digital device, pursuant to part 15 of the FCC Rules. These limits are designed to provide reasonable protection against harmful interference in a residential installation. This equipment generates, uses and can radiate radio frequency energy and, if not installed and used in accordance with the instructions, may cause harmful interference to radio communications. However, there is no guarantee that interference will not occur in a particular installation. If this equipment does cause harmful interference to radio or television reception, which can be determined by turning the equipment off and on, the user is encouraged to try to correct the interference by one or more of the following measures:

- Reorient or relocate the receiving antenna.
- Increase the separation between the equipment and receiver.
- Connect the equipment into an outlet on a circuit different from that to which the receiver is connected.

• Consult the dealer or an experienced radio/TV technician for help.
TM © 2014 Microsoft Mobile. All rights reserved. Microsoft, Windows, the Windows logo and Lumia are trademarks of the Microsoft group of companies. Third party products/names may be TMs of their respective owners.

The Bluetooth word mark and logos are owned by the Bluetooth SIG, Inc. and any use of such marks by Microsoft Mobile is under license.

This product is licensed under the MPEG-4 Visual Patent Portfolio License (i) for personal and noncommercial use in connection with information which has been encoded in compliance with the MPEG-4 Visual Standard by a consumer engaged in a personal and noncommercial activity and (ii) for use in connection with MPEG-4 video provided by a licensed video provider. No license is granted or shall be implied for any other use.

Additional information, including that related to promotional, internal, and commercial uses, may be obtained from MPEG LA, LLC. See www.mpegla.com (in English).



Confidential
jedrocha
David Zhang; PCO reviewer
2014-12-01 10:38
© 2014 Microsoft

Confidential
jedrocha
David Zhang; PCO reviewer
2014-12-01 10:38
© 2014 Microsoft

Confidential
jedrocha
David Zhang; PCO reviewer
2014-12-01 10:38
© 2014 Microsoft

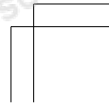
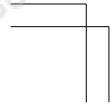

Confidential
jedrocha
David Zhang; PCO reviewer
2014-12-01 10:38
© 2014 Microsoft

Confidential
jedrocha
David Zhang; PCO reviewer
2014-12-01 10:38
© 2014 Microsoft

Confidential
jedrocha
David Zhang; PCO reviewer
2014-12-01 10:38
© 2014 Microsoft

Confidential
jedrocha
David Zhang; PCO reviewer
2014-12-01 10:38
© 2014 Microsoft

Confidential
jedrocha
David Zhang; PCO reviewer
2014-12-01 10:38
© 2014 Microsoft

Confidential
jedrocha
David Zhang; PCO reviewer
2014-12-01 10:38
© 2014 Microsoft



MANUFACTURER'S LIMITED WARRANTY

1. GENERAL

Microsoft Mobile Oy (hereinafter "Manufacturer"), its affiliated companies, in case of Mexico, Ventas de Celulares México, S.A. de C.V., a subsidiary of Microsoft Mobile Oy, ("Manufacturer") provides this Manufacturer's Limited Warranty ("Warranty") for the genuine product (the "Product"), which has been released for sale in Latin America ("Covered Countries"). Ventas de Celulares México, S.A. de C.V. has its main offices at Guillermo González Camarena Piso 14, Colonia Lomas de Santa Fe, Deleg. Alvaro Obregón, C.P. 01210, México D.F., México. The Warranty may be enforced at the Authorized Service Centres identified herein.

This Warranty is distinct from any statutory rights under any mandatory consumer protection laws of your country applicable to you. It is intended to grant you specific, and as the case may be, additional rights, within the limits of what is permissible under such law, and does not limit the rights you may have under applicable statutory product warranty provisions. You may have other rights based on local laws during or after the Warranty period. These rights are not excluded by this Warranty.

2. WARRANTY

From the date the Product is sold to an end-user for the first time, as evidenced by the original proof of purchase, Manufacturer warrants the Product is free from defects in materials and workmanship ("Defect") as follows:

- (i) Twelve (12) months for the main device;
 - (ii) Twelve (12) months for accessories sold separately or included in the sales pack of the main device excluding batteries, covers, cables and chargers; and
 - (iii) Six (6) months for all batteries, covers, cables and chargers, unless otherwise specified in the Product user guide.
- During the warranty period, Manufacturer will, in a reasonable time, remedy the Defect free of charge by either repairing or replacing the defective Product or the defective part of it at its option provided that you have informed Manufacturer of the Defect before the warranty period expires. When repairing or replacing your Product, Manufacturer may use new or re-conditioned parts or products.

To the fullest extent permitted by applicable law, no repair or replacement will renew or extend the warranty period. Original or replacement parts or replacement Products provided under this Warranty will be covered by this Warranty for the remainder of the

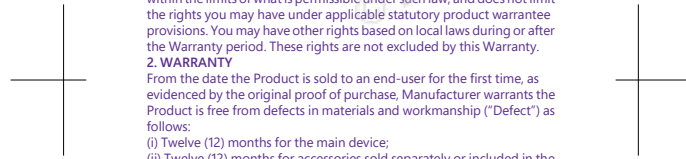

Confidential
jedrocha
David Zhang; PCO reviewer
2014-12-01 10:38
© 2014 Microsoft

Confidential
jedrocha
David Zhang; PCO reviewer
2014-12-01 10:38
© 2014 Microsoft

Confidential
jedrocha
David Zhang; PCO reviewer
2014-12-01 10:38
© 2014 Microsoft

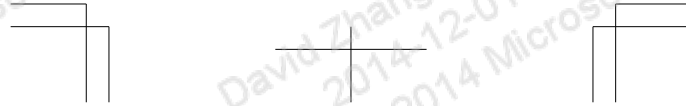

Confidential
jedrocha
David Zhang; PCO reviewer
2014-12-01 10:38
© 2014 Microsoft

Confidential
jedrocha
David Zhang; PCO reviewer
2014-12-01 10:38
© 2014 Microsoft

Confidential
jedrocha
David Zhang; PCO reviewer
2014-12-01 10:38
© 2014 Microsoft

Confidential
jedrocha
David Zhang; PCO reviewer
2014-12-01 10:38
© 2014 Microsoft

Confidential
jedrocha
David Zhang; PCO reviewer
2014-12-01 10:38
© 2014 Microsoft

Confidential
jedrocha
David Zhang; PCO reviewer
2014-12-01 10:38
© 2014 Microsoft

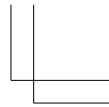
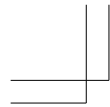

Confidential
jedrocha
David Zhang; PCO reviewer
2014-12-01 10:38
© 2014 Microsoft

original warranty period or for sixty (60) days from the date of repair or replacement, whichever is longer.
The Product or all parts of your Product that Manufacturer has replaced shall become Manufacturer's property.
Manufacturer does not warrant that software preinstalled by or on behalf of Manufacturer in the Product (or subsequent updates and upgrades) (together "Manufacturer software") will meet your requirements, work in combination with any hardware or software not provided by Manufacturer, is uninterrupted or error free or that errors are correctable or will be corrected. For Manufacturer software related errors, Manufacturer will make available the latest version of the Manufacturer software for reinstallation on your Product or, if that would not be possible, another remedy, which in Manufacturer's reasonable discretion, satisfactorily addresses the error. Some Manufacturer software may be subject to separate license terms that are available with the software or your local section of www.microsoft.com/mobile.
Please always back up all data and content stored on your Product before taking your Product in for service since service activities will erase all data from your Product.

Confidential
jedrocha
David Zhang; PCO reviewer
2014-12-01 10:38
© 2014 Microsoft



3. WHAT THIS WARRANTY DOES NOT COVER

- Manufacturer does not provide any warranty for the following:
- 1 User guides;
 - 2 Any (i) third party software, settings, content, data, or links installed or downloaded onto your Product at any time, or (ii) Manufacturer and third party services or enabling clients even if preinstalled by Manufacturer (please read the terms and conditions that may accompany the services as those will define your rights and obligations);
 - 3 Any (i) normal wear and tear, (ii) reduced charging capacity of the battery resulting from its natural end of product life, or (iii) pixel defects in your Product's display that are within the scope of industry standards;
 - 4 SIM card and/or any cellular or other networks or system on which your Product operates; or
 - 5 Errors or damage caused by: (i) misuse or not using your Product in accordance with the user guide, such as if the Product has been exposed to moisture, to dampness or to extreme thermal or environmental conditions or to rapid changes in such conditions, to corrosion, to oxidation, to spillage of food or liquid or to influence from chemical products, (ii) using your Product with, or connecting it to, any product, accessory, software, or service not manufactured or supplied by Manufacturer, (iii) any products combined with your Product by a third party, (iv) damage or errors caused by hacking, cracking, viruses, or other malware, or by unauthorised access to services, accounts, computer

Confidential
jedrocha
David Zhang; PCO reviewer
2014-12-01 10:38
© 2014 Microsoft

Confidential
jedrocha
David Zhang; PCO reviewer
2014-12-01 10:38
© 2014 Microsoft

Confidential
jedrocha
David Zhang; PCO reviewer
2014-12-01 10:38
© 2014 Microsoft

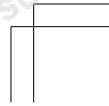
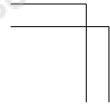

Confidential
jedrocha
David Zhang; PCO reviewer
2014-12-01 10:38
© 2014 Microsoft

Confidential
jedrocha
David Zhang; PCO reviewer
2014-12-01 10:38
© 2014 Microsoft

Confidential
jedrocha
David Zhang; PCO reviewer
2014-12-01 10:38
© 2014 Microsoft

Confidential
jedrocha
David Zhang; PCO reviewer
2014-12-01 10:38
© 2014 Microsoft

Confidential
jedrocha
David Zhang; PCO reviewer
2014-12-01 10:38
© 2014 Microsoft

Confidential
jedrocha
David Zhang; PCO reviewer
2014-12-01 10:38
© 2014 Microsoft

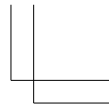
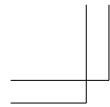

Confidential
jedrocha
David Zhang; PCO reviewer
2014-12-01 10:38
© 2014 Microsoft

systems or networks; or (v) other acts beyond Manufacturer's reasonable control.

This Warranty is not valid:

- 1 Outside of the Covered Countries;
- 2 If your Product, or the software it runs on, has been (i) opened, modified, or repaired without Manufacturer's authorization, or (ii) repaired with unauthorised spare parts;
- 3 If your Product's serial number, the mobile accessory date code, or the IMEI number has been removed, erased, defaced, altered or if these are illegible in any way;
- 4 If you have not installed the latest software updates that are publicly available for your Product within a reasonable time of their release; or
- 5 If you refuse to give possession of the Product to Manufacturer for repair and investigation.

If this Warranty does not cover your Product or the issue based on which it requires service, Manufacturer reserves the right to charge for the repair or replacement of your Product, as well as a handling fee.

4. LIMITATION OF MANUFACTURER'S LIABILITY

To the extent permitted by applicable law(s), Manufacturer shall not under any circumstances be liable, either expressly or impliedly, for any 1 Damages or losses of any kind whatsoever resulting from or relating to loss of, damage to, or corruption of, content or data or the recreation or transfer thereof even if such loss, damage, or corruption was a result of a Defect in your Product; and/or

2 Loss of profit, products or functionality, business, contracts, revenues or anticipated savings, increased costs or expenses, or for any indirect, consequential or special loss or damage.

To the extent permitted by applicable law, Manufacturer's liability shall be limited to the purchase value of your Product.

The limitations in this clause 4 shall not apply in case of Manufacturer's negligence or intentional misconduct or in case of death or personal injury resulting from Manufacturer's proven negligence.

5. OTHER IMPORTANT NOTICES

For further information on your Warranty, as well as information needed to process your warranty queries, please visit www.microsoft.com/mobile.

Please ensure your operator has removed any SIM-locks (or other equivalent mechanisms that may lock your Product to a specific network or operator) prior to delivering your Product for repair.

Your Product may contain country specific elements, including software. The warranty services available in a particular country may be limited to the Products and country specific elements available in that country.



Confidential
jedrocha
David Zhang; PCO reviewer
2014-12-01 10:38
© 2014 Microsoft

Confidential
jedrocha
David Zhang; PCO reviewer
2014-12-01 10:38
© 2014 Microsoft

Confidential
jedrocha
David Zhang; PCO reviewer
2014-12-01 10:38
© 2014 Microsoft

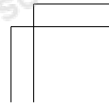
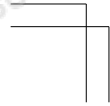

Confidential
jedrocha
David Zhang; PCO reviewer
2014-12-01 10:38
© 2014 Microsoft

Confidential
jedrocha
David Zhang; PCO reviewer
2014-12-01 10:38
© 2014 Microsoft

Confidential
jedrocha
David Zhang; PCO reviewer
2014-12-01 10:38
© 2014 Microsoft

Confidential
jedrocha
David Zhang; PCO reviewer
2014-12-01 10:38
© 2014 Microsoft

Confidential
jedrocha
David Zhang; PCO reviewer
2014-12-01 10:38
© 2014 Microsoft

Confidential
jedrocha
David Zhang; PCO reviewer
2014-12-01 10:38
© 2014 Microsoft

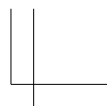

Also, if your Product has been re-exported from its original destination to another country, your Product may contain country specific elements that are not considered a defect under this Warranty even if it would not be operational.

Confidential
jedrocha
David Zhang; PCO reviewer
2014-12-01 10:38
© 2014 Microsoft

Confidential
jedrocha
David Zhang; PCO reviewer
2014-12-01 10:38
© 2014 Microsoft

Confidential
jedrocha
David Zhang; PCO reviewer
2014-12-01 10:38
© 2014 Microsoft



Confidential
jedrocha
David Zhang; PCO reviewer
2014-12-01 10:38
© 2014 Microsoft

Confidential
jedrocha
David Zhang; PCO reviewer
2014-12-01 10:38
© 2014 Microsoft

Confidential
jedrocha
David Zhang; PCO reviewer
2014-12-01 10:38
© 2014 Microsoft

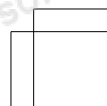
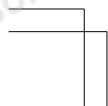

Confidential
jedrocha
David Zhang; PCO reviewer
2014-12-01 10:38
© 2014 Microsoft

Confidential
jedrocha
David Zhang; PCO reviewer
2014-12-01 10:38
© 2014 Microsoft

Confidential
jedrocha
David Zhang; PCO reviewer
2014-12-01 10:38
© 2014 Microsoft

Confidential
jedrocha
David Zhang; PCO reviewer
2014-12-01 10:38
© 2014 Microsoft

Confidential
jedrocha
David Zhang; PCO reviewer
2014-12-01 10:38
© 2014 Microsoft

Confidential
jedrocha
David Zhang; PCO reviewer
2014-12-01 10:38
© 2014 Microsoft

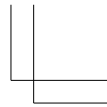
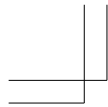

Confidential
jedrocha
David Zhang; PCO reviewer
2014-12-01 10:38
© 2014 Microsoft



Limited Warranty Certificate

For devices purchased in Latin America and Caribbean

Purchaser: _____

Model: _____

ESN: _____

ID: _____

Date of purchase: _____

Address (Authorised Service Center):



Confidential
jedrocha
David Zhang; PCO reviewer
2014-12-01 10:38
© 2014 Microsoft

Confidential
jedrocha
David Zhang; PCO reviewer
2014-12-01 10:38
© 2014 Microsoft

Confidential
jedrocha
David Zhang; PCO reviewer
2014-12-01 10:38
© 2014 Microsoft

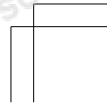
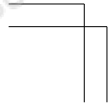

Confidential
jedrocha
David Zhang; PCO reviewer
2014-12-01 10:38
© 2014 Microsoft

Confidential
jedrocha
David Zhang; PCO reviewer
2014-12-01 10:38
© 2014 Microsoft

Confidential
jedrocha
David Zhang; PCO reviewer
2014-12-01 10:38
© 2014 Microsoft