

Nokia 6170 User Guide

FCC DRAFT

Quick guide

- Make a call** Enter a phone number, and press **Call**.
- Answer a call** Press **Call**, or open the fold.
- Answer call during call** Select **Options > Answer call**.
- End a call** Press **End**.
- Decline a call** Press **End**.
- Mute a call** Select **Mute** during a call.
- Redial** Press **Call**.
- Adjust call volume** Press the **Volume** keys on the left side of the phone during a call.
- Use the in-call menu** Select **Options** during a call.
- Save a name and number** Enter a number, select **Save**, enter a name, and select **OK**.
- Use 1-touch dialing** Press and hold a key (**2–8**). You must assign a key to a number in **Contacts**.
- Look up a name** Select **Contacts > Find**.
- Check voice mail** Press and hold the **1** (contact your service provider for details).
- Write and send text messages** Select **Menu > Messages > Text messages > Create message**. Enter the message, and select **Send**. Enter the number, and select **OK**.
- Send a picture message** Select **Menu > Messages > Text messages > Create message > Options > Insert picture**. Scroll to the picture you want, and select **View > Insert**. Enter the text message, and select **Send**. Enter the number, and select **OK**.
- Read a new message** If **New Message** appears, select **Read**, highlight the message, and select **Read** again.
- Press** Press a key briefly and release it.
- Press and hold** Press and hold a key for 2 to 3 seconds and release it.

DECLARATION OF CONFORMITY

We, NOKIA CORPORATION declare under our sole responsibility that the products RM-47 and RM-48 are in conformity with the provisions of the following Council Directive: 1999/5/EC.

A copy of the Declaration of Conformity can be found at http://www.nokia.com/phones/declaration_of_conformity/.

CE 168

LEGAL INFORMATION

PART NO. 9235535 ISSUE NO. 1

Copyright © 2004 Nokia. All rights reserved.

Nokia, Nokia Connecting People, Pop-Port, Xpress-on, Nokia Original Enhancements, Nokia 6170, and the Nokia Original Enhancements logos are trademarks or registered trademarks of Nokia Corporation. Other company and product names mentioned herein may be trademarks or trade names of their respective owners.

Printed in Canada 10/2004

US Patent No 5818437 and other pending patents. T9 text input software

Copyright © 1999-2004. Tegic Communications, Inc. All rights reserved.



Includes RSA BSAFE cryptographic or security protocol software from RSA Security.



Java is a trademark of Sun Microsystems, Inc.

USE OF THIS PRODUCT IN ANY MANNER THAT COMPLIES WITH THE MPEG-4 VISUAL STANDARD IS PROHIBITED, EXCEPT FOR USE DIRECTLY RELATED TO (A) DATA OR INFORMATION (i) GENERATED BY AND OBTAINED WITHOUT CHARGE FROM A CONSUMER NOT THEREBY ENGAGED IN A BUSINESS ENTERPRISE, AND (ii) FOR PERSONAL USE ONLY; AND (B) OTHER USES SPECIFICALLY AND SEPARATELY LICENSED BY MPEG LA, L.L.C.

The information contained in this user guide was written for the Nokia 6170 product. Nokia operates a policy of ongoing development. Nokia reserves the right to make changes to any of the products described in this document without prior notice.

UNDER NO CIRCUMSTANCES SHALL NOKIA BE RESPONSIBLE FOR ANY LOSS OF DATA OR INCOME OR ANY SPECIAL, INCIDENTAL, AND CONSEQUENTIAL OR INDIRECT DAMAGES HOWSOEVER CAUSED. THE CONTENTS OF THIS DOCUMENT ARE PROVIDED "AS IS." EXCEPT AS REQUIRED BY APPLICABLE LAW, NO WARRANTIES OF ANY KIND, EITHER EXPRESS OR IMPLIED, INCLUDING, BUT NOT LIMITED TO, THE IMPLIED WARRANTIES OF MERCHANTABILITY AND FITNESS FOR A PARTICULAR PURPOSE, ARE MADE IN RELATION TO THE ACCURACY AND RELIABILITY OR CONTENTS OF THIS DOCUMENT. NOKIA RESERVES THE RIGHT TO REVISE THIS DOCUMENT OR WITHDRAW IT AT ANY TIME WITHOUT PRIOR NOTICE.

EXPORT CONTROLS

This device may contain commodities, technology or software subject to export laws and regulations from the US and other countries. Diversion contrary to law is prohibited.

FCC/INDUSTRY CANADA NOTICE

Your device may cause TV or radio interference (for example, when using a telephone in close proximity to receiving equipment). The FCC or Industry Canada can require you to stop using your telephone if such interference cannot be eliminated. If you require assistance, contact your local service facility. This device complies with part 15 of the FCC rules. Operation is subject to the condition that this device does not cause harmful interference.

Manufactured or sold under one or more following US Patents.
 Asterisk (*) indicates design patents pending.

4868846	5519885	5827082	5966378	6112099	6266330
4969192	5526366	5835889	5970059	6115617	6282436
5001372	5553125	5839101	5987137	6118775	6285888
5045973	5557639	584884	5991716	6121846	6292668
5101175	5565821	5845219	5991857	6122498	6295286
5212834	5570369	5857151	5999523	6128322	6308084
5230091	5581244	5862178	6005857	6128509	6310609
5233634	5597102	5870683	6011853	6138091	6311054
5241284	5625274	5887266	6014573	6140966	6314166
5241583	5640395	5889770	6018277	6144243	6324412
5266782	5664004	5892475	6026161	6144676	6347218
5311151	5664053	5898925	6028567	6148209	6356759
5311179	5669069	5907823	6029128	6151485	6359904
5317283	5677620	5914690	6038238	6151507	6363259
5331638	5678224	5914796	6043760	6163609	6370362
5335362	5692032	5915440	6047196	6164547	6370390
5353328	5699406	5917868	6049796	6167248	6377803
5378935	5699482	5920826	6050415	6170073	6393121
5384782	5701392	5926138	6055439	6178535	6430721
5390223	5729534	5926769	6060193	6185295	6434133
5396657	5729541	5930233	6069923	6188909	*29/170210
5400949	5734683	5946651	6072787	6195338	*29/170229
5416435	5754976	5956332	6081534	6199035	*29/170245
5442521	5760568	5956625	6084962	6201876	*29/170246
5444816	5782646	5956633	6088746	6219560	
5446364	5794142	5960354	6094587	6240076	
5479476	5802465	5960389	6097964	6240079	
5487084	5805084	5963901	6105784	6249584	
5493255	5805301	5966374	6108553	6259312	

Contents

Quick guide	ii	Predictive text entry	20
1. For your safety.	1	Tips for writing text	21
About your device	2	5. Messages.	22
Network Services	2	Linked messages	22
Shared memory	3	Font size	22
2. About your phone	4	Text and picture messages	23
Register your phone	4	Multimedia messages	25
Terms	4	Instant messaging	27
Find information about your		Voice messages	32
phone	4	Info message service	32
Get help	5	Service commands	33
Phone introduction—		Message counter	33
fold closed	6	6. Contacts	34
Phone introduction—		Menu	34
fold open	7	Save information	34
Start screen	8	Change the primary number	35
Copyright protection	11	Search for an entry	36
Accessibility solutions	11	Make a call	36
Nokia PC Suite	11	Add an image to a contact	36
Connection settings service	11	Edit an entry	36
Phone menus	12	Delete names and numbers	36
3. Basic operations.	13	Copy entries	37
Open the fold	13	Business cards	37
Install the battery and		1-touch dialing	38
SIM card	13	Voice dialing	38
Charge the battery	15	Caller groups	39
Attach the wrist strap	15	Contacts view and memory	40
Switch the phone on and off	16	7. Call log	41
Antenna	16	Missed, received, and	
Keyguard	17	dialed calls	41
Make calls	17	Location information	41
Answer calls	18	8. Settings.	42
Loudspeaker	18	Profiles	42
Options during a call	19	Themes	43
4. Text entry	20	Tone settings	43
Traditional text entry	20		

Main display settings.....	43	Emergency call while online... ..	78
Mini display settings.....	43	Options while online.....	79
Time and date settings.....	43	Security.....	79
Personal shortcuts.....	44		
Connectivity.....	45	14. SIM services.....	82
Call settings.....	47	15. Hardware and	
Phone settings.....	49	enhancements.....	83
Enhancement settings.....	50	Hardware.....	83
Configuration settings.....	51	Enhancements.....	83
Security settings.....	51	16. Reference Information....	84
Restore factory settings.....	55	Battery information.....	84
9. Gallery.....	56	Enhancements.....	84
Folders.....	56	Enhancements, batteries,	
Edit an image.....	56	and chargers.....	85
10. Media.....	57	Care and maintenance.....	85
Camera.....	57	Additional safety information..	86
Media player.....	58	Technical information.....	90
Voice recorder.....	59	Appendix A	
11. Organizer.....	60	Message from the CTIA... ..	95
Alarm clock.....	60	Appendix B	
Calendar.....	61	Message from the FDA... ..	99
To-do list.....	63	Index.....	107
Notes.....	63		
Synchronization.....	64		
Wallet.....	66		
Calculator.....	69		
Stopwatch.....	70		
Countdown timer.....	71		
12. Applications.....	72		
Games.....	72		
Collection.....	73		
13. Mobile Internet services... ..	75		
Set up for browsing.....	75		
Service inbox.....	77		
File download.....	78		
Disconnect from the			
mobile Internet.....	78		

For your safety

1 For your safety

Read these simple guidelines. Not following them may be dangerous or illegal. Read the complete user guide for further information.



SWITCH ON SAFELY

Do not switch the phone on when wireless phone use is prohibited or when it may cause interference or danger.



ROAD SAFETY COMES FIRST

Obey all local laws. Always keep your hands free to operate the vehicle while driving. Your first consideration while driving should be road safety.



INTERFERENCE

All wireless phones may be susceptible to interference, which could affect performance.



SWITCH OFF IN HOSPITALS

Follow any restrictions. Switch the phone off near medical equipment.



SWITCH OFF IN AIRCRAFT

Follow any restrictions. Wireless devices can cause interference in aircraft.



SWITCH OFF WHEN REFUELING

Don't use the phone at a refueling point. Don't use near fuel or chemicals.



SWITCH OFF NEAR BLASTING

Follow any restrictions. Don't use the phone where blasting is in progress.



USE SENSIBLY

Use only in the normal position as explained in the product documentation. Don't touch the antenna unnecessarily.



QUALIFIED SERVICE

Only qualified personnel may install or repair this product.



ENHANCEMENTS AND BATTERIES

Use only approved enhancements and batteries. Do not connect incompatible products.



WATER-RESISTANCE

Your phone is not water-resistant. Keep it dry.



BACK-UP COPIES

Remember to make back-up copies or keep a written record of all important information stored in your phone.



CONNECTING TO OTHER DEVICES

When connecting to any other device, read its user guide for detailed safety instructions. Do not connect incompatible products.



EMERGENCY CALLS

Ensure the phone is switched on and in service. Press **End** as many times as needed to clear the display and return to the main screen. Enter the emergency number, then press **Call**. Give your location. Do not end the call until given permission to do so.

• About your device

The wireless device described in this guide is approved for use on the GSM 850/1800/1900 and GSM 900/1800/1900 networks. Contact your service provider for more information about networks.

When using the features in this device, obey all laws and respect the privacy and legitimate rights of others.



Warning: To use any features in this device, other than the alarm clock, the phone must be switched on. Do not switch the device on when wireless phone use may cause interference or danger.

• Network Services

To use the phone you must have service from a wireless service provider. Many of the features in this device depend on features in the wireless network to function. These Network Services may not be available on all networks or you may have to make specific arrangements with your service provider before you can utilize Network Services. Your service provider may need to give you additional instructions for their use and explain what charges will apply. Some networks may have limitations that affect how you can use Network Services. For instance, some networks may not support all language-dependent characters and services.

Your service provider may have requested that certain features be disabled or not activated in your device. If so, they will not appear on your device menu. Contact your service provider for more information.

For your safety

• Shared memory

The following features in this device may share memory: contacts, text and multimedia messages, instant messaging, voice tags, images, ringing tones, video clips, sound clips, camera, calendar, to-do notes, notes, and Java™ games and applications. Use of one or more of these features may reduce the memory available for the remaining features sharing memory. For example, saving many gallery items may use all of the available memory. Your phone may display a message that the memory is full when you try to use a shared memory feature. In this case, delete some of the information or entries stored in the shared memory features before continuing. Some of the features may have a certain amount of memory specially allotted to them in addition to the memory shared with other features.

Refer to the appropriate area of this User Guide for information on how to manage the features and data in your device.

2 About your phone

Congratulations on your purchase of the Nokia 6170 mobile phone.

• Register your phone

Be sure to register your phone at www.warranty.nokiausa.com or call 1-888-NOKIA-2U (1-888-665-4228) so that we can serve you better if you need to call a customer center or to have your phone repaired.

• Terms

This guide uses certain terms for the parts of the phone and the steps that you are asked to perform.

- **Highlighted** options on the screen are enclosed within a bar. The selection keys are used to act on the highlighted option.
- **Left selection** key and **Right selection** key are used to select the options on the left and right bottom corners of the screen.
- **Four-way scroll and selection** key is used to navigate through names, phone numbers, menus, and settings. It is also used to move the cursor up, down, left, and right when writing text, using the calendar, and in some game applications. Pressing the key briefly in the middle selects the item in the bottom center of the screen. The middle of the **Four-way scroll and selection** key is also called the **Middle selection** key. The top, bottom, left, and right edges of the **Four-way scroll and selection** key are also called the **Scroll up**, **Scroll down**, **Scroll left**, and **Scroll right** keys.
- **Select** means to press the **Left selection** key or the **Right selection** key, or to press the center of the **Four-way scroll and selection** key (the **Middle selection** key). To select an option, press the selection key below the menu item on the phone screen.
- **Call** key. Press **Call** to place a call or to answer an incoming call.
- **End** key. Press **End** to end a call or to return to the start screen.

• Find information about your phone

An information label under the battery contains the following information:

- Model number
- Phone type and FCC ID
- International mobile equipment identity (IMEI)

• Get help

If you need help, Nokia Customer Care is available for assistance. We recommend that you write down the following information and have it available if you call.

- The IMEI printed on the back of the phone, beneath the battery
- Your zip code

Contact Nokia

Please have your phone or enhancement with you when contacting the numbers below.

Nokia Customer Care Center, USA	Customer Care, Canada
Nokia Inc. 7725 Woodland Center Boulevard Suite 150 Tampa, Florida 33614 Tel: 1-888-NOKIA-2U (1-888-665-4228) Fax: 1-813-249-9619 TTY: 1-800-24-NOKIA (1-800-246-6542) (for TTY users only)	Nokia Products Ltd. 601 Westney Road South Ajax, Ontario L1S 4N7 Tel: 1-888-22-NOKIA (1-888-226-6542) Fax: 1-905-619-4360

Contact your service provider

To use the network services available in your phone, you will need to sign up with a service provider. In many cases, the service provider will make available descriptions of their services and instructions for using certain features.

Service providers may differ in their support of features. Before you sign up, make sure a service provider supports the features that you need.

Guide updates

From time to time, Nokia updates this guide to reflect changes. The latest version may be available at www.nokia.com/us.

Online tutorials

An interactive tutorial for this product may be available at the Web site www.nokiahowto.com.

In-phone help

Many features have brief descriptions (help text) that can be viewed on the display. To view help text, scroll to a feature and wait for about 15 seconds for the help text to appear.

The default setting for help text is **On**. To activate or deactivate help text: Select **Menu > Settings > Phone settings > Help text activation > On or Off**.

• Phone introduction—fold closed

- Mini display (1)
- Loudspeaker (2)
- Charger connector (3)
- Microphone (4)
- Pop-Port™ connector (5) used for headsets and the data cable.
- Camera lens (6)
- **Power** key (7) switches the phone on and off.

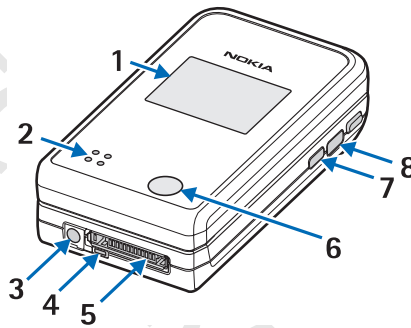

When the keypad is locked, press the **Power** key briefly to turn the display lights on for approximately 15 seconds.

- Infrared (IR) port (8)

• Phone introduction—fold open

- Ear piece (1)
- Main display (2)
- **Left, middle, and right selection keys (3)**
The function of these keys depends on the guiding text shown on the display above the keys. See "Main display" on page 8.
- **End key (4)** ends an active call, and exits from any function. Press and hold to exit from any function.
- **Number keys (5)** enter numbers and characters; * and # keys are used for various purposes depending on the function.

Press and hold  to open the web start page, if mobile Internet services are available and configured. Mobile Internet services are network-dependent. Contact your service provider for more information.

- **Up, down, left, and right scroll keys (6)**
Use to scroll through contacts, menus, settings, calendar dates, and feature options, or to move the cursor when writing text.
- **Call key (7)** dials a phone number, and answers a call.
- **Volume keys (8)** adjust the earpiece, the loudspeaker, or the headset volume (it is connected).

When the fold is closed, use the volume keys to mute the ringing tone of an incoming call, to switch the alarm clock to snooze, or to mute.

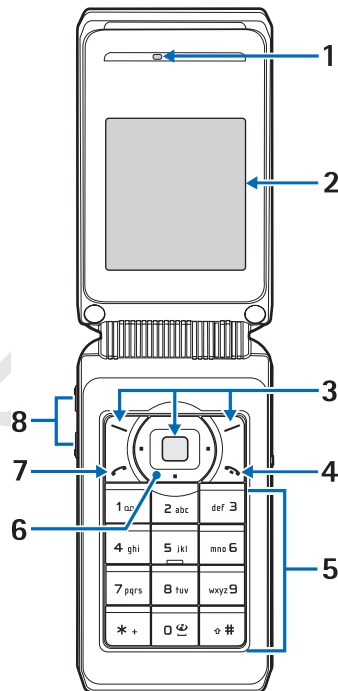

• Start screen

When the phone is ready for use, and you have not keyed in any characters, the phone is in the start screen.

Mini display

When the fold is closed, the mini display may show the following information:

- The signal strength of the cellular network at your current location, and the battery charge level
- The name of the network or a text note indicating that the phone is not in service
- The time and date, the active profile, and the alarm clock or calendar note alerts
- The caller's name or number of an incoming call and the caller, if identified

Main display

- Name of the network or the operator logo to indicate in which cellular network the phone is currently being used (1)
- Signal strength of the cellular network at your current location (2). The higher the bar, the stronger the signal.
- Battery charge level (3). The higher the bar, the more charge in the battery.
- The **Left selection key** (4) in the start screen is **Go to**.

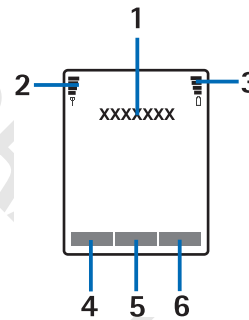

Select **Go to** to view the list of functions that are in your personal shortcut list.

Select any function to activate it, or select

Options to access the following options:

Select options—View the list of all available functions. Scroll to a function, and select **Mark** to add it to the shortcut list. To remove a function from the shortcut list, select **Unmark**. If there are no functions on the shortcut list, select **Add** to add a function.

Organize—Rearrange the functions on the list. Scroll to the function that you want to move, select **Move** and one of the moving options.

- The **Middle selection key** (5) in the start screen is **Menu**.
- The **Right selection key** (6) in the start screen may be:

Names—to access the **Contacts** menu

The operator-specific key—to access an operator's homepage

Personal shortcut—a specific function for the **Right selection key** menu.

See "Personal shortcuts" on page 44.

Screen saver









You can select an image for the screen saver on the mini display, and set the phone to activate it after a certain length of time if no phone function is used. See "Mini display settings" on page 43.

The phone automatically activates the digital clock screen saver on the main display in the start screen, and also on the mini display if you have not selected a screen saver for it. If you have not set the time, 00:00 is displayed.





















Shortcuts in the start screen

- To access the list of dialed numbers, press **Call**. Scroll to the desired number, and press **Call** to dial the number.
- To call your voice mailbox when you have saved your voice mailbox number in the phone, press and hold **1**.
- To connect to a browser service, press and hold **0**.
- To find a name in the contacts list, scroll down.
- To write a text message, scroll left.
- To open the camera viewfinder in standard photo view, scroll up. To change to video, scroll left. To change to portrait photo, scroll right.
- To select a profile when the keypad is unlocked, briefly press the **Power** key, scroll to the desired profile, and press and hold the **Power** key.

Indicators and icons

Icon	Indicates...
	You have one or more text or picture messages. See "Read a message" on page 24.
	You have one or more multimedia messages. See "Read and reply" on page 27.
	You have one or more voice messages. See "Voice messages" on page 32.
	You have a delivery note, sent by your network, in the inbox. See "Settings" on page 23.
 or 	Your phone is connected to an instant message service, and the availability status is online or offline. See "Instant messaging" on page 27.
	Your phone is connected to an instant message service, and you have received one or more instant messages. See "Instant messaging" on page 27.
	The phone has registered a missed call. See "Call log" on page 41.

Icon Indicates...

-  Your phone keypad is locked. See "Keyguard" on page 17.
-  Your phone does not ring for an incoming call or text message when **Incoming call alert** is set to **Off** or none of the caller groups has been set to alert in the **Alert for** setting, and **Message alert tone** is set to **Off**. See "Customize a profile" on page 42.
-  The alarm clock is set to **On**. See "Alarm clock" on page 60.
-  The timer is running. See "Countdown timer" on page 71.
-  The stopwatch is running in the background. See "Stopwatch" on page 70.
-  The GPRS connection mode **Always online** is selected, and the GPRS service is available. The indicator is shown on the top left of the display. See "GPRS modem settings" on page 46.
-  A GPRS dial-up connection is established. The indicator is shown on the top left of the display. See "GPRS modem settings" on page 46.
-  The GPRS dial-up connection is suspended. For example, you have an incoming or outgoing call during a GPRS connection. The indicator is shown on the top right of the display.
-  IR connection indicator is shown continuously when the IR connection is activated. See "Infrared" on page 45.
-  Forward all voice calls. All calls are forwarded to another number. If you have two phone lines, the indicator for line 1 is  and for line 2 .
-  **1** or **2** If you have two phone lines, this indicator displays the selected phone line. See "Phone settings" on page 49.
-  Loudspeaker is active. See "Loudspeaker" on page 18.
-  Calls are limited to a closed user group. See "Closed user groups" on page 53.
-  The timed profile is selected. See "Profiles" on page 42.
-  A headset, hands-free, loopset, or music stand enhancement is connected to the phone.
-  or 
- 

• Copyright protection

Copyright protections may prevent some images, ringing tones, and other content from being copied, modified, transferred, or forwarded.

• Accessibility solutions

Nokia is committed to making mobile phones easy to use for all individuals, including those with disabilities. For more information, visit www.nokiaaccessibility.com.

• Nokia PC Suite

Nokia PC Suite is a collection of powerful software tools that let your phone work with a compatible PC to manage phone features and data. For more information, consult the Nokia PC Suite online help. Nokia PC Suite software and documentation can be downloaded from www.nokia.com/us.

• Connection settings service

To use browsers, MMS, GPRS, and other wireless services, you must have the proper connection settings on your phone. Your service provider may be able to send the settings directly to you as a connection settings message. You only need to save the settings on your phone. For more information about the availability of the settings, contact your service provider or nearest authorized Nokia dealer.

You may be able to receive the connection settings for multimedia messages, IM, synchronization, streaming, and the browser.

If you receive the connection settings as a message and the settings are not automatically saved and activated, **Connection settings received** is displayed. You can do one of the following:

- To save the received settings, select **Save**. If **Enter settings' PIN** is displayed, enter the PIN code for the settings, and select **OK**. For the PIN code, contact the service provider that supplies the settings.

If no settings have been saved yet, the settings are saved and set as default configuration settings. Otherwise, the phone asks **Set as default settings?**.

- To discard the received settings, select **Discard**.

You may need to activate the settings as described in the section for that service.

You can also find the settings in the support section of www.nokia.com/us.

• Phone menus

Phone features are grouped according to function and are accessed through the main menus of your phone. Each main menu contains submenus and lists from which you can select or view items and customize phone features.



Note: Some features may not be available, depending on your network. For more information, contact your service provider.

You can choose from two types of menu style: **List** and **Grid**. See "Main display settings" on page 43 or "Scroll method" on page 12 to switch between styles.

In the **List** style, the menu names are listed in the conventional way. In the **Grid** style, multiple menu icons appear on a single display.

To use menus and submenus, scroll or use a shortcut.

Scroll method

- 1 At the start screen, use the **Middle selection** key to select **Menu**.
- 2 In the **List** view, scroll through the main menus one at a time using the **Scroll up** and **Scroll down** keys.
- 3 As you scroll through the menus, the menu number (1) appears in the upper right corner of the display. Below the menu number is a scroll bar with a tab (2). The tab moves up or down as you scroll through the menus, providing a visual representation of your current position in the menu structure.
- 4 To change between the **List** and **Grid** view, select **Settings > Main display settings > Menu view > List** or **Grid**.
- 5 In the **Grid** view, use all four scroll keys to navigate through the menu icons. The icon for the selected menu is highlighted (1), and the name (2) of the menu appears at the top of the display.
- 6 When the desired menu is highlighted, press the **Middle selection** key.
- 7 If the menu contains submenus, use the scroll keys to highlight the desired menu; then press the **Middle selection** key.
 - Select **Back** (press the **Right selection** key) to return to the previous menu or submenu.
 - Press **End** to return to the start screen from any main menu.

Shortcuts

Menus and options are numbered so that you can quickly key-press your way to an option. The numbers appear in the top right corner of the screen and show your location in the menu.

Select **Menu** and, quickly, enter the first number of the menu function you want to access. Repeat until you have entered all the numbers.

3 Basic operations

- **Open the fold**

When you open the fold of the phone, it automatically opens to about 150 degrees. Do not try to force the fold open further.

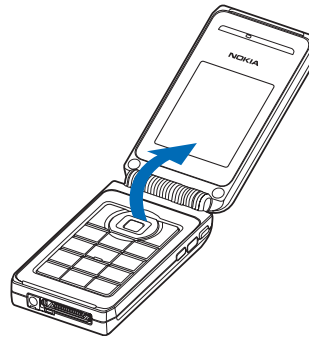

- **Install the battery and SIM card**

Keep all SIM cards out of the reach of small children. For availability and information on using SIM card services, contact your SIM card vendor. This may be the service provider, network operator, or other vendor.

The SIM card and its contacts can easily be damaged by scratches or bending, so be careful when handling, inserting, or removing the card.



Note: Before installing or removing the battery or SIM card, always verify that the phone is switched off and disconnected from any enhancement.



Note: Avoid touching electronic components while changing cover. Store and use your device with its covers attached.

- 1 With the phone closed and the back of the phone facing you, press the release button and lift the cover to remove it from the phone.

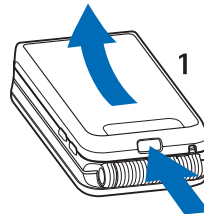

- 2 Remove the battery.

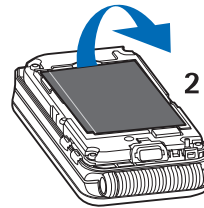

- 3 To open the SIM card holder, gently pull up on the locking clip.
- 4 Insert the SIM card into the SIM card holder so that the gold-colored contact area on the card is facing downwards. Ensure that the SIM card is properly inserted.
- 5 Close the cover of the SIM card holder, and press it gently to snap into place.

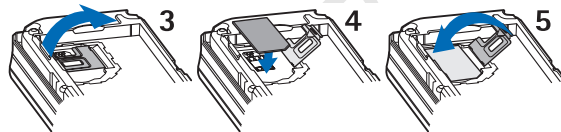

- 6 Replace the battery. Ensure that the battery terminals are in the proper position.

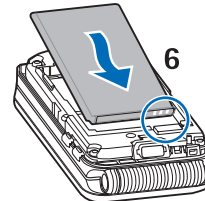

Basic operations

- 7 Slip the locking catches of the cover into the corresponding catches on the phone.
- 8 Press the opposite end of the cover down onto the cover release button until it snaps into place.

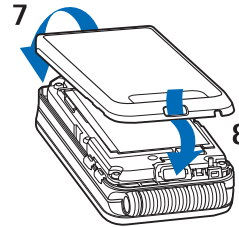

• Charge the battery



Warning: Use only batteries, chargers, and enhancements approved by Nokia for use with this particular model. The use of any other types may invalidate any approval or warranty and may be dangerous. Check the model number of any charger before use with this device. This device is intended for use when supplied with power from ACP-12, ACP-7, AC-1, and LCH-12.

- 1 Connect the charger to a wall socket.
- 2 Connect the plug from the charger to the jack on the bottom of your phone.

On the main display, the battery indicator scrolls during charging. If the power is on, **Charging** appears briefly when the charger is first attached. If the battery is completely discharged, it may take a few minutes before the charging indicator appears on the display or before any calls can be made.

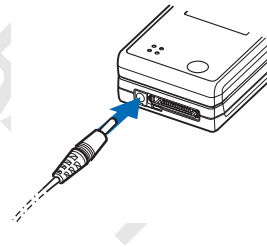

You can use the phone while the charger is connected.

The charging time depends on the charger and the battery used. For example, charging a fully discharged BL-4C battery with a ACP-7 charger takes approximately 3 hours, and with a ACP-12 charger, approximately 1 hour and 30 minutes while the phone is in the standby mode.

• Attach the wrist strap

Wrist strap is available as an accessory. Check availability with your local Nokia dealer.

- 1 Remove the cover from the phone. See "Install the battery and SIM card" on page 13.

- 2 Thread the strap.
- 3 Close the cover. See "Install the battery and SIM card" on page 13.

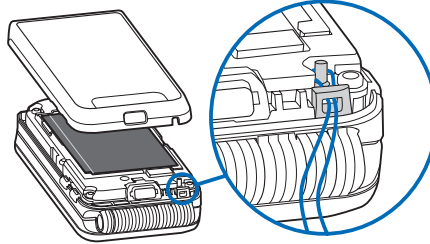

• Switch the phone on and off

 **Warning:** Do not switch the phone on when wireless phone use is prohibited or when it may cause interference or danger.

To switch the phone on or off, press and hold the **Power** key.

If the phone displays **Insert SIM card** or **SIM card not supported**, even though the SIM card is properly inserted, contact your network operator or service provider. Your phone does not support 5-V SIM cards.

If the phone requests a PIN code or a security code, enter the code, and select **OK**. See also "Access codes" on page 54.

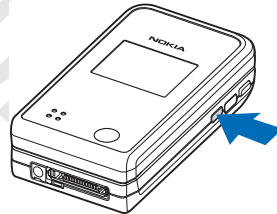

• Antenna

Hold the phone as you would any other telephone. Your phone has an internal antenna.

Basic operations

Note: As with any other radio transmitting device, do not touch the antenna area unnecessarily when the device is switched on. Contact with the antenna area affects call quality and may cause the phone to operate at a higher power level than otherwise needed. Avoiding contact with the antenna area when operating the phone optimizes the antenna performance and the battery life.

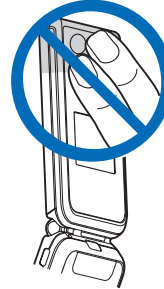

• Keyguard

With keyguard, you can lock the keypad to prevent keys from being pressed accidentally. See "Security keyguard" on page 49.

If the keypad is locked, it unlocks when you receive a call. After a call, the lock automatically reactivates.

To lock the keypad, at the start screen, select **Menu > ***.

To unlock the keypad, at the start screen, select **Unlock > ***, and enter the security code if required.



Note: When keyguard is on, calls may be possible to the emergency number programmed into your phone (for example, 911). Key in the emergency number, and press **Call**. The number is displayed only after you have keyed in its last digit.

• Make calls

Use the keypad

- 1 Open the fold, enter the phone number (including the area code), and press **Call**.
To delete a character to the left of the cursor, select **Clear**.
- 2 To end the call or to cancel the call attempt, press **End**.

Use contacts

- 1 At the start screen, scroll down; then scroll to the entry you wish to view.
To search the list of entries quickly, press the key with the letter that matches the first letter of the contact name.
- 2 Press **Call** to make the call, or select **Details** to view details of the entry.

Use 1-touch dialing

Before using 1-touch dialing, you must assign a phone number to a key (2–9). See "1-touch dialing" on page 38.

If 1-touch dialing is set to **On** in the call settings, press and hold the assigned 1-touch dialing key until the call is started.

• Answer calls

When you receive a call, the phone shows the caller's name, phone number, or displays **Private number** or **Call**. The information appears in the mini display if the phone is closed, or in the main display if the phone is open.

To answer a call, press **Call**.

To decline a call, open the fold and quickly close it again. If the fold is already open, press **End** to decline the call. If **Forward if busy** is activated on your voice mailbox, the call is forwarded to your voice mail. If not, the call is declined.

If you select **Silence**, only the ringing tone is muted. You can still answer or decline the incoming call.

If a compatible headset with a headset key is connected to the phone, you can answer or end a call by pressing the headset key.

Call waiting

During a call, press **Call** to answer the waiting call. The first call is put on hold. Press **End** to end the active call.

To activate call waiting, see "Call waiting" on page 49.

Answer with the keys locked

To answer a call with keyguard on, open the fold or press **Call**. During the call, all features function as normal. When you end or decline the call, the keypad automatically relocks.

• Loudspeaker

You can use your phone as a loudspeaker during a call.

 **Warning:** Do not hold the device near your ear when the loudspeaker is in use because the volume may be extremely loud.

To activate the loudspeaker, select **Loudsp**; to deactivate it, select **Normal**.

To activate a headset, if attached, select **Loudsp > Heads..**

The loudspeaker is deactivated automatically when a call (or a call attempt) ends or when certain enhancements are connected.

• Options during a call

Many of the options that you can use during a call are network services. To check availability, contact your network operator or service provider.

During a call, you can select **Options** to access the available options. Some of the options are as follows:

Hold—Put a call on hold.

Mute—The caller will hear silence.

Contacts—Access your contacts list.

New call—Place a new call; the first call is put on hold (network service).

Menu—Display the main menus.

Lock keypad—Lock the keypad to prevent an accidental key press.

Record—Record the call. See "Record a phone call" on page 59.

End call—End a call.

Touch tones—Send touch tones generated by your phone keypad. Enter the touch tone string or search for it in contacts, and select **Tones**.

Loudspeaker—Listen to the call on the loudspeaker.

4 Text entry

Use two methods to enter text and numbers.

• Traditional text entry

Traditional text entry (predictive text off) is the only way to enter names into contacts and to rename caller groups. In standard mode, the icon  appears in the upper left corner of the display.

Press a key once to insert the first letter on the key, twice for the second letter, etc. If you pause briefly, the last letter in the display is accepted, and your phone waits for the next entry.

To insert a name from contacts, select **Options > Add new contact**, and search for the name. To insert a phone number or text item attached to the selected name, select **Options > View details**.

• Predictive text entry

Predictive text entry (predictive text on) is a quick and easy method for writing messages. When predictive text is on, the icon  appears in the upper left corner of the display.

Press # to switch between traditional text entry, predictive text entry, uppercase, lowercase, and sentence case. **ABC**, **abc**, and **Abc** appear in the upper left of the display, indicating uppercase, lowercase, and sentence case.

To switch to numeric entry, press and hold # and select **Number mode**. To switch back to text entry, press and hold #, and select **Writing language**.

Activate predictive text

At a text entry screen, select **Options > Predictive text** and the desired language.

The selection of a writing language does not affect the language used in the phone menus, displays, and messages.

Enter text

- For each letter of the word that you want to spell, press the corresponding key *once*, even if the letter you want is not the first letter on the key. The phone guesses the word you are trying to spell.
- If a displayed word is not correct, press * repeatedly to see other matches.
- Press 0 to accept the word and enter a space. Then begin writing the next word.
- To insert a word, select **Options > Insert word**, write the word using traditional text input, and select **Save**. The word is also added to the dictionary.
- If ? appears after a word, select **Spell** to add the word to the dictionary. See "Add new words to the dictionary" on page 21.

Compound words

Enter the first part of the word and scroll right to confirm it. Enter the last part of the word and confirm it by pressing **0**.

Add new words to the dictionary

If you encounter a word that predictive text does not recognize, **?** follows the word, and **Spell** appears in the bottom center of the display.

Select **Spell**, enter your new word using the keypad, and select **Save**. The word is added to the dictionary and to the message that you are writing. When the dictionary is full, the most recent addition replaces the first.

• Tips for writing text

- Press **0** to enter a space, and press **1** to enter a period (.).
- To move the cursor left or right, scroll left or right.
- To delete a character, select **Clear**. Select and hold **Clear** to continuously delete characters. Select **Options > Clear text** to delete all of the characters at once when writing a message.
- To switch between upper and lower case, or between traditional and predictive text, press **#** repeatedly, and check the indicator at the top of the display.
- To switch between letters and numbers, press and hold **#**.
- To enter a number, press and hold the desired key.
- To display special characters, press *****. (Press and hold ***** in predictive text.) Press ***** again to display smileys. Scroll to the character you want, and select **Insert**. In traditional text entry, to enter punctuation marks and other special characters, press **1** repeatedly.

5 Messages



If you have subscribed to a message network service, you can send messages to and receive messages from compatible phones that are also subscribed to compatible message services. You can also send and receive picture messages and multimedia messages, if supported by your service provider. To send and receive messages, you need a messaging service through your service provider, and a message center number saved in your phone. See "Text entry" on page 20 for more information.



Note: When sending messages, your device may display **Message Sent**.

This is an indication that the message has been sent by your device to the message center number programmed into your device. This is not an indication that the message has been received at the intended destination. For more details about messaging services, check with your service provider.



Important: Exercise caution when opening messages. Messages may contain malicious software or otherwise be harmful to your device or PC.

• Linked messages

Your phone can send and receive long text messages. Long text messages are automatically split into multiple messages and sent as a series. For this feature to work properly, the receiving phone must also support linked messages.

While you write a message, the number of available characters and the current part number of linked message (for example, 120/2) are shown.

While receiving linked messages, you can start reading the first part before the phone has received the entire message. If you may see ***some text missing*** on the display, the message content will be updated as soon as the missing sequence arrives.

If the memory is full, you may have to delete a message from your inbox or outbox before your phone can update the missing text. See "Delete messages" on page 25 for more information.

• Font size

Select **Menu > Messages > Message settings > Other settings > Font size > Small font** or **Large font**.

• Text and picture messages

Settings

- 1 Select **Menu > Messages > Message Settings > Text messages > Sending profile**.
- 2 If more than one message profile set is supported by your SIM card, select the set you want to change and select one of the following:
 - Message center number**—Save the phone number of the message center, which is necessary for sending text messages; obtain this number from your service provider.
 - Messages sent via**—Select the message type **Text**, **Page**, or **Fax**.
 - Message validity**—Define how long the network attempts to send your messages before it gives up.
 - Default recipient number**—For text messages, the default number used to send messages.
 - Delivery reports**—Request the network to send delivery reports on your messages. When a delivery report is received, it goes to the inbox, and  displays.
 - Use GPRS**—Set GPRS as the preferred method of sending text messages.
 - Reply via same center**—Allow the recipient of your message to send you a reply message using your message center (network service).
 - Rename sending profile**—Change the name of the selected profile. This option is available only if your SIM card supports multiple sending profiles. It is not available for the default profile.



Folders

You can use folders to organize text and picture messages.

Select **Menu > Messages** and one of the following folders:



- Inbox**—Messages are automatically stored in the inbox after they have been read or if you select **Exit** when **Message received** appears on the start screen.
- Outbox**—Contains messages you have sent and are waiting to be transmitted.
- Sent items**—Messages that you have sent are automatically stored in this folder if **Save sent messages** is set to **On** in the message settings for text messages and multimedia messages.
- Saved items**—You can store messages in this folder that you have read or that you want to send later.

Write and send a message

 indicates the message you composed has not been sent.  indicates the message you composed has been sent.

- 1 Select **Menu > Messages > Create message > Text messages**, or scroll left at the start screen.
- 2 Compose a message using the keypad.
- 3 To list available options while composing the message, select **Options** and one of the listed options.
To save the message in the **Saved items** folder, select **Save message > Saved text msgs. or Templates**, to save the message as a predefined template. If you have defined any folders under **My folders**, they also appear in the list, and you can save the message to one of them.
- 4 To send the text message to a single address, select **Send**; enter the recipient's phone number, and select **OK**; or select **Find** to retrieve a number from contacts, and press **Select**.
- 5 For other sending options, select **Options > Sending options** and one of the options, and follow the prompts.

Read a message

When you receive a text or picture message or SMS e-mail,  and *n* **Message(s) received** appear in the display, where *n* is the number of new messages.  indicates a message that has been read.

The blinking  indicates that the message memory is full. Before you can receive new messages, delete some of your old messages. See "Delete messages" on page 25 for more information.

- 1 To view the message immediately, select **Show**.
- 2 To save the message to the inbox for later viewing, select **Exit**.
- 3 To view a saved message, select **Menu > Messages > Inbox**.
- 4 If more than one message is received, select the message you want to read.
 indicates unread messages.
- 5 While viewing the message, select **Options** and one of the listed options.
To extract numbers and Web site addresses from the current message, select **Use detail**.
To copy text from the message to the phone calendar as a reminder note for the current day, select **Copy to calendar**.

Reply to a message

- 1 While viewing a message, select **Reply > Text message**.
- 2 Compose your reply and send the message as described in "Write and send a message" on page 24.

Forward a message

AS A TEXT MESSAGE

- 1 While viewing a message, select **Options > Forward > Via text message**.
- 2 Edit the message if desired, and select **Send**.
- 3 Enter the recipient's phone number, or select **Find** to retrieve it from contacts, and select **OK**.

Delete messages

If your message memory is full and you have more messages waiting at the network,  blinks in on the start screen. You must read and delete unread messages, or delete messages from some of your folders.

To delete a single message, select **Menu > Messages**, the folder, the message you want to delete, and **Options > Delete > Yes**.

To delete all messages in a folder, select **Menu > Messages > Delete messages**, the folder, and **Yes**.

• Multimedia messages

A multimedia message is indicated by  and can contain text, sound, and a picture. Your phone supports multimedia messages that are up to 100 KB. Only compatible devices can receive and display multimedia messages.

The default setting of the multimedia message service is **On**. The appearance of a multimedia message may vary depending on the receiving device.

Multimedia messaging supports the following formats:

- Picture: JPEG, GIF, WBMP, BMP, OTA-BMP, and PNG
- Sound: SP-MIDI, AMR audio, and monophonic ringing tones
- Video: 3GP format (H.263 baseline and MPEG-4 simple profile)

If a received message contains unsupported elements, these elements may be replaced with the file name.

You cannot receive multimedia messages if you have a call in progress, a game or other Java application running, or an active browsing session over GSM.

Because delivery of multimedia messages can fail for several reasons, do not rely solely upon them for essential communications.

MMS settings

CONNECTION SETTINGS MESSAGE

You may be able to receive multimedia connection settings as a connection settings message from your service provider. For more information, contact your service provider.

MANUAL ENTRY

Contact your service provider for the settings.

Select **Menu > Messages > Message settings > Multimedia msgs. > Configuration settings > Edit active multimedia settings** and each of the settings in turn, and enter the required information.

OTHER MMS SETTINGS

Select **Menu > Messages > Message settings > Multimedia msgs.** and one of the following:

Save sent messages—Select **Yes** to save sent multimedia messages to the **Sent items** folder or **No** to discard.

Delivery reports—Select **On** for the network to send reports about your messages (network service).

Scale image down—Select **Yes** to scale images to a smaller size when inserted into a message or **No** to keep the original size.

Default slide timing—Set the default time in *mm:ss* format for each slide in an MMS to remain on the screen.

Allow multimedia reception—Select **Yes**, **No**, or **In home network** for your multimedia service. **In home network** cannot receive multimedia messages outside the home network.

Incoming multimedia messages—Select **Retrieve** to receive multimedia messages or **Decline** to not receive multimedia messages.

Configuration settings—Select **Configuration > Default** or **Personal config.** according to which configuration settings support the multimedia messaging. See "Configuration settings" on page 51.

Allow advertisements—Select **Yes** to enable reception of automatic multimedia advertisements or **No** to disable.

Write and send



- 1 Select **Menu > Messages > Create message > Multimedia msg.**, and enter the text of your message.
- 2 To insert an image, sound or video clip, select **Options > Insert** and the type.
- 3 Open the desired **Gallery** folder, scroll to the file, and select **Options > Insert**.
Copyright protections may prevent some images, ringing tones, and other content from being copied, modified, transferred, or forwarded.
- 4 To add a new page (also called a slide) to the message, select **Options > Insert > Slide**.

Each slide can contain text, one image, a calendar note, a business card, and one sound clip. If the message contains several slides, to open the desired slide, select **Previous slide**, **Next slide**, or **Slide list**.

- 5 To set other message properties, follow the prompts.

It takes more time to send a multimedia message than to send a text message. While the multimedia message is being sent,  is displayed, and you can use other functions on the phone. If sending fails, the message remains in the **Outbox** folder, and you can try to resend it later. Check your **Outbox** folder for unsent messages. Messages that you have sent are saved in the **Sent items** folder if the setting **Save sent messages** is set to **Yes**. See "Other MMS settings" on page 26. This is not an indication that the message has been received at the intended destination.

Read and reply

When a multimedia message is being received,  blinks in the display. Once the message has been fully downloaded,  and **Multimedia message received** appear in the display.

- 1 To view the message immediately, select **Show**.
- 2 To save the message to the inbox for later viewing, select **Exit**.
- 3 To view a saved message, select **Menu > Messages > Inbox**, and scroll to view the message. Unread messages are indicated by .
- 4 While viewing the message, select **Play** to view the entire MMS, or select **Options** and the desired action.

If  blinks and **Multimedia memory full, view waiting msg.** appears, memory for multimedia messages is full. To view the waiting message, select **Show**. Before you can save the message, you need to delete some of your old messages. See "Delete messages" on page 25 for more information.

• Instant messaging

Take text messaging to the next level by experiencing instant messaging (IM) in a wireless environment. Engage in instant messaging with friends and family, regardless of the mobile system or platform they are using (like the Internet), as long as you all use the same IM service. Check with your wireless service provider for availability.

Before you can start using IM on your phone, you must first subscribe to your wireless service provider's text messaging service. GPRS network service is required to use instant messaging. You must also register with the IM service you want to use. See "Register with an IM service" on page 28 for more information.



Note: Depending on both your IM service provider and your wireless service provider, you may not have access to all of the features described in this guide.

Register with an IM service

Before you can use IM, you must register with an IM service to obtain an IM user name and password. You can obtain an IM user name and password by registering over the Internet (using your computer) with the IM service provider you have selected. During the registration process, you will have the opportunity to create the user name and password of your choice. For more information about signing up for IM services, contact your wireless service provider.

IM icons and menu items

Each IM service provider has its own unique interface, so the IM menu items, screen display text, and icons on your phone may appear differently for each IM service. If you have questions about the differences in the various IM service providers' screen text and icons, contact your wireless service provider for more information.

IM menus

OFFLINE

When you select **IM** from your phone menu, a list of available IM services is displayed. Select the desired IM service to access the IM offline menu options: **Login**, **Saved convers.**, and **Settings**. Depending on the IM service provider you are using, these may not be the exact menu items displayed. See "IM icons and menu items" on page 28.

ONLINE

After you log into IM, the following IM online menu options appear: **Conversations**, **IM contacts**, **Add contact**, **Create group**, **Saved convers.**, **IM availability**, **Settings**, **Blocked list**, and **Logout**. Depending on the IM service provider you are using, these may not be the exact menu items displayed. See "IM icons and menu items" on page 28.

Log in

- 1 Select **Menu > IM**.
- 2 Select the IM service you want to log into.
You must select the IM service every time you log in.
- 3 Select **Login**.
- 4 At the prompt, enter your user name if it is not already displayed, and select **OK**.
- 5 At the prompt, enter your password, and select **OK**.

Depending on your IM service, you may not need to enter your user name and password manually every time you log in.

After you have logged into IM the first time, you can choose to log in automatically or you can continue logging in manually. See the **Automatic login** option under "IM settings" on page 31.

Begin an IM session

You can send instant messages to anyone if you have the person's user name and you use the same IM service. As the conversation progresses, the most recent message appears at the top of the screen, causing the previous messages to move down one level (some IM services may do this in the opposite direction). If you want to chat with a person, you must first add that person to **IM Contacts**. See "IM contacts" on page 30.

To begin an IM session with one contact:

- 1 From the **IM** online menu, select **IM contacts**.
- 2 Scroll to a contact who is online, and press **Select > Open**.
A conversation screen is opened, and the contact's name is displayed at the top.
- 3 Select **Write**, and enter a message. See "Text entry" on page 20.
- 4 When you finish the message, select **Send**.

Begin a group chat

You can create your own private chat groups. The participants must be entered into **IM contacts**. See "IM contacts" on page 30.

- 1 From the **IM** online menu, select **Create group**.
- 2 Enter the group name (up to 10 characters), and select **OK**.
- 3 After your screen name appears, select **OK**.
The group chat screen is displayed.
- 4 To add group members, select **Options > Group members**.
- 5 Select the contact whom you want to invite to the group chat.
- 6 Enter the invitation text, and select **Send**.

Receive and reply to messages

If you have an active chat open and receive an instant message from the contact or group member with whom you are chatting, the new message is displayed on the conversation screen in the sequence in which they are received. Select **Write** to reply.

If you receive an instant message when you have the IM application open but do not have an active chat open, a screen appears showing you have a new instant message with the name of the sender. Select **Open** to open the conversation screen with that contact's new message displayed. To reply, select **Write**, enter a message, and select **Send**.

If you receive an instant message when you are logged in to the IM service but do not have the IM application open on your phone, a message is displayed telling you that a new IM message has been received. Select **Start** to open the IM application and view the new message.

Return to chat session

From the **IM** online menu, select **Conversations**. This list displays all IM conversations and group chats in which you are currently participating. To view a conversation or continue chatting, scroll to a group name or contact name, and press **Select**.

IM contacts

You can add the names of contacts with whom you interact frequently by instant messaging to the **IM contacts** list.

ADD A NEW CONTACT

To add a person to **IM Contacts** during an instant messaging session, select **Options > Add**.

To add a new contact from the IM online menu, select **Add contact**. Enter the contact's user name for the IM service, and select **OK**. Enter a nickname for the contact, and select **OK**. The contact is added to your **IM contacts** list.

To add a new contact from the IM contacts list, select any contact to open the IM contacts menu. Select **Add contact**, enter the contact's user name for the IM service, and select **OK**. Enter a nickname for the contact, and select **OK**. The contact is added to your **IM contacts** list.

REMOVE A CONTACT

From the **IM** online menu, select **IM contacts** and the contact you want to remove; then select **Remove contact > OK**.

BLOCK OR UNBLOCK CONTACTS

To block or unblock instant messages from a contact, select **IM Contacts** from the IM online menu, the contact name, and **Block contact** or **Unblock > OK**.

To view a list of the contacts you have blocked, select **Blocked list** from the IM online menu.

Save chat session

You can save a chat session while you have the conversation open. Select **Options > Save**, edit the name if desired, and select **Save**.

To view a saved chat session, go to the IM online menu, select **Saved convers.** and the desired conversation name to open it for viewing. While viewing the saved conversation, you can select **Delete** or **Options > Rename**.

Set your availability

You can determine if other users can tell whether you are available or not. From the **IM** online menu, select **IM Availability > Available for all**, **Available for contacts**, or **Appear offline**.

IM settings

You can customize your IM settings, depending upon the IM service you have selected. From the IM online menu, select **Settings** and one of the following:

Screen name—Enter a screen name (also called an alias or a nickname) that is 1–20 characters in length. This name is shown in front of the messages that you send to your contacts. It is also your default screen name when you join a group chat.

Automatic login—You can use automatic login after you have logged in at least once to an IM service with your user name and password. When you select **IM** from the phone main menu and then select the same IM service provider, you are then logged in automatically and do not have to enter your user name and password.

Sort contacts—Specify whether you want your IM contacts to be displayed **Alphabetically** or **By status**.

Status updates—Select **On** if you want your IM contacts list to be updated when a contact's availability changes. If you set this feature to **Off**, you can select **Refresh list** from the IM contacts menu to update your contacts' status manually.

Network—Modify network connection settings for the IM service.

Log off service

EXIT INSTANT MESSAGING

From the IM online menu, you can exit the IM application but still be connected to the IM service. Select **Back** until the IM online menu appears; then select **Exit**. If you open **IM** again, you do not need to log in again.

You can then receive instant messages and chat invitations from your contacts when using your phone for other purposes, such as playing a game. If you are connected to your IM service, but you have not used your IM application for some time, you may be automatically disconnected from the IM service. The next time you open the IM application, **Not connected** is displayed, and you are taken to the offline menu where you have to log in again.

LOG OUT OF INSTANT MESSAGING

To disconnect from the IM service, you must log out from the online menu. You will be taken to the IM service provider list, where you can exit the IM application or select an IM service and log in again.

From the IM online menu, select **Logout > OK**.

• Voice messages

If you subscribe to voice mail, your service provider will furnish you with a voice mailbox number. You must save this number to your phone to use voice mail. When you receive a voice message, your phone lets you know by beeping, displaying a message, or both. If you receive more than one message, your phone shows the number of messages received. If supported by the network,  indicates new voice messages.

Save your voice mailbox number

Your service provider may have already saved your voice mailbox number to your phone. If so, the number will appear in the display in step 2. Select **OK** to leave the number unchanged.

- 1 Select **Menu > Messages > Voice messages > Voice mailbox number**.
- 2 If the **Mailbox number** box is empty, enter the voice mailbox area code and number, and select **OK**.

Call and set up your voice mail

- 1 Once you have saved the voice mailbox number, press and hold **1**.
- 2 When you connect to voice mail and the prerecorded greeting begins, follow the service's automated instructions to setup your voice mail.

Listen to your voice messages

Once you have set up voice mail, you can dial the number in the following ways:

- Enter the voice mailbox number.
- Press and hold **1**.
- Select **Listen** if there is a notification message in the display.

After a brief pause, your phone dials the voice mail number. Once you connect and the prerecorded greeting begins, follow the automated instructions to listen to your voice messages.

• Info message service

With the info message network service, you can receive short text messages from your service provider on various topics, such as weather and traffic conditions. Contact your service provider for more information.

Select **Menu > Messages > Info messages** and follow the prompts to configure your service.

Info service—Select **On** or **Off** to activate or deactivate the service, or **Topic index** to activate index reception.

Messages



Note: If the **GPRS connection** is set to **Always online**, info messages may not be received. In that case, set the **GPRS connection** to **When needed**. See "GPRS, EDGE, CSD, HSCSD" on page 45 for more information.

• Service commands

Use the **Service commands** editor to enter and send service requests (also known as USSD commands) to your service provider. Contact your service provider for information about specific service commands.

- 1 Select **Menu > Messages > Service commands**.
- 2 Enter a service request, such as an activation command for a specific network service, and select **Send**.

• Message counter

To view the number of text and multimedia messages you have sent and received, select **Menu > Messages > Message counter > Sent messages** or **Received messages**.

To clear the counters, select **Clear counters**.

6 Contacts



Contacts can be saved in the phone memory and on the SIM card. The phone memory can save up to 500 entries. You can also save an image with some of the names. The amount of names, numbers and text entries that you can save varies, depending on their length and the total number of entries in contacts.  indicates contacts saved on the SIM card.

• Menu

Select **Menu > Contacts** and one of the following:

Find—Find a name or select from a list.

Add new contact—Add a name to contacts.

Delete—Delete a name and its associated numbers.

Copy—Copy entries from phone memory to SIM and vice versa.

Settings—Set memory in use (phone or SIM), change contacts view, and check the memory status of your phone and SIM card.

1-touch dialing—Display the list of 1-touch dialing numbers saved to memory.

Voice tags—Display and manage voice tags. See "Voice dialing" on page 38.

My numbers—View the numbers (line 1, line 2, data) in use by your SIM card.

Caller groups—View and edit the properties (such as the ringing tone) for any of the caller groups.

• Save information

You can save names and numbers to phone memory or to SIM memory. See "Contacts view and memory" on page 40.

Quickly save a name and number

- 1 At the start screen, enter the phone number you wish to save, and select **Save**.
- 2 Enter a name for the number, and select **OK**.

Save an entry

- 1 Select **Menu > Contacts > Add new contact**.
- 2 Enter a contact name, and select **OK**.
- 3 Enter a phone number, and select **OK > Done**.

Save multiple numbers and text items

For each entry in phone memory, you can save different types of phone numbers and short text items. The first number you save for any entry is automatically set as the default, or primary number. It is indicated with a frame around the number type indicator. If you save multiple numbers, you can designate another number as the primary number if desired. See "Change the primary number" on page 35.

- 1 Select **Menu > Contacts > Settings**.
- 2 Make sure that the memory in use is either **Phone** or **Phone and SIM**.
See "Contacts view and memory" on page 40.
- 3 At the start screen, scroll down; then scroll to the contact entry to which you want to add a number or text item.
- 4 Select **Details > Options > Add number** or **Add detail** and the desired information category.
- 5 Select an information category, enter the information, and select **OK**.
- 6 To change the number or text type, with a number or text item highlighted, select **Options > Change type** and the desired type.
You cannot change the type of an instant messaging user ID if it is in the **Subscribed names** list or in the contact list for group chat.
- 7 Press **End** to return to the start screen.

Save addresses and notes

To save an address or note, you need to add it to an existing entry (name).

- 1 At the start screen, scroll down; then scroll to the entry to which you want to add an address or note.
- 2 With the entry highlighted, select **Details > Options > Add detail > Web address, Street address, or Note**.
- 3 Enter the text for the note or address, and select **OK**.

• Change the primary number

In a contact with more than one phone number, you can select which number should be the primary number. When you highlight the contact and press **Call**, the phone automatically dials the primary number.

- 1 At the start screen, scroll down; then scroll to the entry you want to change, and select **Details**.
- 2 Scroll to the number you want to set as default, and select **Options > Set as default**.

• Search for an entry

- 1 At the start screen, scroll down to display the contents of **Contacts**.
- 2 Press the key that corresponds to the first letter of the name for which you are searching.
- 3 Select **Details** to view the details of the selected entry.
- 4 Scroll up and down through the details of the entry, if necessary.

• Make a call

At the start screen, scroll down; then scroll to the entry for the person you want to call.

To dial the primary number, press **Call**.

To dial one of the other numbers for that contact, select **Details**, scroll to the desired number, and press **Call**.

• Add an image to a contact

You can add an image to a name or number saved in phone memory. That image is displayed when you receive a call from that phone number.

- 1 At the start screen, scroll down.
- 2 Scroll to the name or number, and select **Details > Options > Add image**.
The display shows the list of folders in the **Gallery**.
- 3 Scroll to the folder that contains the image, and select **Open**.
- 4 Scroll to the desired image, and select **Options > Save to contacts**.

A copy of the image is added to the contact.

You can use the phone to take a photo and attach it to the contact. See "Take a photo" on page 57 for more information.

• Edit an entry

- 1 At the start screen, scroll down; then scroll to the entry that you want to edit, and select **Details**.
- 2 Scroll to the item you want to edit, and select **Options**.
The list of available options varies according to the type of item selected.
- 3 Select an option, and follow the prompts to edit the item.

• Delete names and numbers

- 1 Select **Menu > Contacts > Delete**.
- 2 To delete individual names and numbers, select **One by one**.
- 3 Scroll to the entry you wish to delete, and select **Delete > Yes** to confirm the deletion.

Contacts

- 4 To delete the entire contents of contacts, select **Delete all > Phone or SIM card > Delete > Yes**.
- 5 At the prompt, enter your security code, and select **OK**.

• Copy entries

Text entries that are saved in the phone memory are not copied to the SIM card.

- 1 Select **Menu > Contacts > Copy > From phone to SIM card** or **From SIM card to phone** and one of the following:
 - One by one**—Selects and copies entries one by one. Go to step 2.
 - All**—Copies all entries from the SIM card or phone. Go to step 3.
 - Primary numbers**—Copies only primary numbers. This appears only if you selected **From phone to SIM card**. Go to step 3.
- 2 Scroll to the entry you wish to copy, and select **Copy > Keep original** or **Move original**.
 - Select **Keep original** if you are unsure of which copy method to use. This ensures original entries are merely copied to the new location. **Move original** deletes files at their former location after copying.
 - The entry is copied and you are returned to the list of contact entries.
- 3 If you selected **All** or **Primary numbers** in step 1, select **Keep original** or **Move original > Yes** to confirm your choice.
 - All entries are copied to the selected destination.
- 4 Press **End** to return to the start screen.

• Business cards

You can send and receive an entry in **Contacts** to a compatible phone or other handheld device using IR or a text or multimedia message, if supported by your service provider.

Receive a business card using IR

- 1 Select **Menu > Settings > Connectivity > Infrared** to ensure IR is activated.
 - When you receive the business card, your phone beeps, and a message appears in the display.
- 2 Select **Show > Save** to save the business card in phone memory or **Exit > OK** to discard the business card.

Send a business card

- 1 Highlight an entry from **Contacts** that you wish to send, and select **Details > Options > Send bus. card > Via infrared, Via text message, or Via multimedia**.
- 2 Follow the prompts to finish sending the business card.

• 1-touch dialing

You can assign any phone number to any key from 2–9, and dial the number by pressing and holding the assigned key. If you assign a number that is not already in your contact list, the number is added to the list.

Assign a key

- 1 Select **Menu > Contacts > 1-touch dialing**.
- 2 Scroll to any empty slot, and select **Assign**.
- 3 Enter the number (including the area code), and select **OK**.
- 4 Enter a name for the number, and select **OK**.

Make a call

Press and hold the key to which an entry has been assigned. Your phone dials the entry assigned to the key.

Change numbers

- 1 Select **Menu > Contacts > 1-touch dialing**.
- 2 Scroll to the 1-touch dialing entry you wish to change, and select **Options > Change**.
- 3 Enter the number (including the area code), and select **OK**.
- 4 Enter a name for the number, and select **OK**.

Delete numbers

- 1 Select **Menu > Contacts > 1-touch dialing**.
- 2 Scroll to the 1-touch dialing location you wish to delete, and select **Options > Delete > Yes**.

• Voice dialing

You can make a phone call by saying a voice tag that has been added to a phone number in contacts. Any spoken word, such as a name, can be a voice tag. Before using voice tags, note that:

- Voice tags are not language-dependent. They are dependent on the speaker's voice.
- You must say the name exactly as you said it when you recorded it.
- Voice tags are sensitive to background noise. Record them and make calls in a quiet environment.
- Very short names are not accepted. Use longer, unique names (for example, "John Smith, work")
- When recording a voice tag or making a call using a voice tag, hold the phone in the normal position at your ear.

Contacts



Note: *Using voice tags may be difficult in a noisy environment or during an emergency, so you should not rely solely upon voice dialing in all circumstances.*

Assign a voice tag

- 1 At the start screen, scroll down to display the entry you would like to assign a voice tag, and select **Details**.
- 2 If the entry has multiple numbers, scroll to the number you wish to tag.
- 3 Select **Options > Add voice tag > Start**.
- 4 After the phone beeps, pronounce the voice tag clearly into the microphone. After the voice tag is recorded, it is replayed through the earpiece, and a confirmation note appears in the display. The  icon is displayed next to the number in the contact list.

Voice dial a number

- 1 At the start screen, press and hold the **Volume down** key or the **Right selection** key; or if you are using a compatible headset with a headset key, press and hold the headset key. The phone beeps, and **Speak now** appears in the display.
- 2 Within 3 seconds, speak the tag into the microphone. Once the voice tag is recognized, the tagged entry appears in the display, replays through the earpiece, and the number is dialed.

Edit voice tags

- 1 Select **Menu > Contacts > Voice tags**.
- 2 Scroll to view the voice tags, select a voice tag, and **Playback, Change, or Delete**.

• Caller groups

You can add contacts entries to any of five caller groups and assign a unique ringing tone or graphic to that group. This enables you to identify callers from the group by their unique ringing tone or graphic. A caller group can be as small as one person or as large as the contacts list. You can rename caller groups to suit your preference. To set the phone to ring only for calls from members of a selected caller group, see the **Alert for** option in "Customize a profile" on page 42.

Set caller group options

- 1 Select **Menu > Contacts > Caller groups > Family, VIP, Friends, Business, or Other > Rename group, Group ringing tone, Group logo, or Group members**.
- 2 Follow the prompts to set the option according to your preference.

Add a name to a caller group

- 1 Recall a name from contacts, and select **Details > Options > Caller groups**.
- 2 Select the caller group to which you want to add the name.

Remove a name from a caller group

- 1 Select **Menu > Contacts > Caller groups > Family, VIP, Friends, Business, or Other > Group members**.
- 2 Scroll to the name you want to remove, and select **Options > Remove contact**.

• Contacts view and memory

At the start screen, select **Contacts > Settings** and one of the following:

Memory in use—Select the memory you wish to use. Options are **Phone**, **SIM card**, or **Phone and SIM** combined. With **Phone and SIM** selected, when you save a new contact entry, it is saved to phone memory only. However, when you display the contact list you can see the entries in both phone memory and the SIM card.

Contacts view—Select the **Name list**, **Name and number**, **Name only**, or **Name and image**.

Memory status—View the amount of phone or SIM memory used and available.

Call log

7 Call log



Call log stores information about the last 20 missed, 20 received, and 20 dialed calls. It also adds the total duration of all calls. When the number of calls exceeds the maximum, the most recent call replaces the oldest. For **Call log** to work properly:

- Your service provider must support caller ID, and it must be enabled.
- Your calls cannot be blocked.
- Your phone must be on and within the service area.

• Missed, received, and dialed calls

- 1 Select **Menu** > **Call log** > **Missed calls**, **Received calls**, or **Dialed numbers**.
- 2 Scroll to a name or number of interest, select **Options**, and one of the listed options.

• Location information

The network may deliver location information of your phone if you approve it (network service). Contact your network operator or service provider to subscribe and to agree upon the delivery of location information.

The network may send you a location request.

To accept or reject the location request, select **Accept** or **Reject**. If you miss the request, the phone automatically accepts or rejects it according to what you have agreed with your network operator or service provider. The phone displays **1 missed position request**. To view the missed location request, select **Show**.

To view the information on the 10 most recent position requests, or to delete them, select **Menu** > **Call log** > **Positioning** > **Position log** > **Open folder** or **Delete all**.

8 Settings



Use this menu to set or change your personal shortcuts, time and date settings, call settings, phone settings, display settings, tone settings, enhancement settings, security settings, and to restore factory settings.

• Profiles

Profiles define how your phone reacts when you receive a call or a message, how your keypad sounds when you press a key, and more. Ringing options, keypad tones, and other settings can be left at their default setting, or customized to suit your needs. Select and customize the most suitable profile for your situation, such as when you are in a meeting or outdoors. The profiles available are **Normal**, **Silent**, **Meeting**, **Outdoor**, and **Pager**.

Profiles are also available for enhancements such as a headset and car kit. See "Enhancement settings" on page 50 for more information about enhancement profiles.

Select a profile

Select **Menu > Settings > Profiles**, a profile from the list, and **Activate**; or in the start screen, briefly press the **Power** key, scroll to the desired profile, and press and hold the **Power** key.

Customize a profile

You can customize any of the profiles a variety of ways.

- 1 Select **Menu > Settings > Profiles**.
- 2 Select the profile you want to customize; select **Customize** and one of the listed options.

For **Alert for**, define which caller groups the selected profile will accept or decline. See "Caller groups" on page 39 for more information.

Set a timed profile

Timed profiles can be used to prevent missed calls. For example, suppose you attend an event that requires your phone be set to **Silent** before the event starts, but you forget to return it to **Normal** until long after the event. During this time, you have missed several calls because the ringing tone was silent.

With the timed profile feature, you can set a profile to expire after any length of time up to 24 hours. When the profile expires, your phone automatically returns to the default profile.

- 1 Select **Menu > Settings > Profiles**, a profile, and **Timed**.
- 2 Enter the time for the profile to expire, and select **OK**.

The profile you have set for expiration is now active and appears in the start screen along with a small clock icon.

• Themes

A theme contains many elements for personalizing your phone, such as wallpaper, screen saver, color scheme, and a ringing tone.

Select **Menu > Settings > Themes** and follow the prompts.

• Tone settings

You can adjust the ringing volume, keypad tones, and more for the active profile.

Select **Settings > Tone settings**.

• Main display settings

Select **Menu > Settings > Main display settings**, and one of the listed options.

• Mini display settings

Images on the mini display may not be as bright as those on the main display.

Select **Menu > Settings > Mini display settings**, and one of the listed options.

• Time and date settings

Set the clock

- 1 Select **Menu > Settings > Time and date settings > Clock > Set the time**.
- 2 Enter the time in *hh:mm* format, and select **OK**.
- 3 If required, select **am** or **pm**.

Show or hide the clock

Select **Menu > Settings > Time and date settings > Clock > Hide clock** or **Show clock**.

Change the time format

You can set the time format for am, pm, or 24-hour format (military time).

Select **Menu > Settings > Time and date settings > Clock > Time format > 24-hour** or **12-hour**.

Set the date

- 1 Select **Menu > Settings > Time and date settings > Date > Set the date**.
- 2 Enter the date, and select **OK**.

Show or hide the date

Select **Menu > Settings > Time and date settings > Date > Show date** or **Hide date**.

Set or change the date format

- 1 Select **Menu > Settings > Time and date settings > Date > Date separator** and the separator of your choice (period, slash, hyphen, or space).
- 2 Select **Date > Date format** and the format of your choice.

Automatic update of date and time

This is a network service. You can set the phone to update the date and time from the network when you turn the phone on. Automatic update of the date and time does not change the time you have set for the alarm clock, calendar, or alarm notes. They are in local time. Updating may cause some alarms that you have set to expire.

Select **Menu > Settings > Time and date settings > Auto-update of date & time** and one of the following:

On—Update the time automatically

Confirm first—Request confirmation before updating the time. You can accept or decline the update.

Off—Do not automatically update the time.

• Personal shortcuts

Right selection key

You can set the **Right selection** key to go directly to a specific function from the start screen.

Select **Menu > Settings > Personal shortcuts > Right selection key** and one of the functions in the list.

The selected name or function appears over the **Right selection** key in the start screen.

Voice commands

Some phone functions can be voice-activated.

- 1 Select **Menu > Settings > Personal shortcuts > Voice commands**, the desired feature, **Select**, the function, and select **Add**.
- 2 Select **Start** and speak after the tone.

See "Voice dialing" on page 38.

You cannot activate or add a voice command during a call or while sending or receiving data over a GPRS connection.

• Connectivity

You can connect the phone to a compatible device or PC using an IR connection or a data cable. You can also use the phone as a wireless modem to enable GPRS mobile link from a compatible PC.

For information on using a data communication application, refer to the documentation provided with the application.

For more information on Nokia PC Suite applications, see the Nokia PC Suite online help. Nokia PC Suite and all related software can be downloaded from www.nokia.com/us.

Infrared

You can send or receive data such as business cards, graphics, images, sound clips, videos, and calendar notes to or from a compatible phone or data device (such as a computer) using the IR port of your phone.

For better performance during an IR connection, place the phone on a stationary surface. Do not move the phone while the IR connection is active. The preferable distance between the two devices in an IR connection is from 3 inches to 3 feet.

Do not point the IR beam at anyone's eye or allow it to interfere with other IR devices. This device is a Class 1 laser product.

SEND AND RECEIVE DATA

- 1 Verify that the IR ports of the sending and receiving devices are pointing at each other and that there are no obstructions between the devices.
- 2 To activate IR in your phone, select **Menu > Settings > Connectivity > Infrared** from the menus.
- 3 The user of the other device should activate IR as well.

If data transfer is not started within 2 minutes after the activation of the IR port, the connection is canceled and must be restarted.

CONNECTION INDICATOR

- When **IR** is shown continuously, the IR connection is activated and your phone is ready to send or receive data using its IR port.
- When **IR** blinks, your phone is trying to connect to the other device or a connection has been lost.

GPRS, EDGE, CSD, HSCSD

With your phone you can use general packet radio service (GPRS), high-speed circuit switched data (HSCSD), and circuit switched data (CSD). The use of HSCSD services uses the battery faster than normal voice or data calls. You may need to connect the phone to a charger during HSCSD data transfer.

With GPRS, you can stay connected to the mobile Internet and allow faster downloads without completing a dial-up connection. Applications using GPRS include MMS, SMS messaging, browsing sessions, remote synchronization, Java application downloading, and the PC dial-up. Your phone can support three simultaneous GPRS connections.

Enhanced GPRS (EGPRS, or EDGE) is similar to GPRS but the connection is faster. To use the EDGE service, subscribe to it from your service provider, and save the GPRS settings for the functions that you want to use over the EDGE network. For information on pricing, availability, and data transfer speed, contact your service provider.

When you have selected GPRS as a data bearer, the phone uses EDGE instead of GPRS if this is available in the network. You cannot choose between EDGE and GPRS, but for some applications, such as browsing mobile Internet pages, you may be able to select either GPRS or CSD.

The phone can support three simultaneous GPRS connections.

DEFINE GPRS CONNECTION

Depending on your service, you may be able to define when the phone connects to the GPRS or EDGE network.

Select **Menu > Settings > Connectivity > GPRS > GPRS Connection** and one of the following:

When needed—The phone registers and connects to the GPRS or EDGE network only if you use a function that needs the GPRS service. The connection closes when you exit the application. Establishing a connection may take longer than when **Always online** is selected.

Always online—The phone automatically registers to a GPRS or EDGE network when you switch the phone on, if the network is available in your location.

When you start an application using GPRS, the connection between the phone and the network is established. When you exit the application, the connection ends, but the phone is still registered to the network.

GPRS MODEM SETTINGS

When you use your Nokia phone as a wireless modem, you can enable a GPRS mobile link from your PC or laptop computer.

Before you can use GPRS technology, you must save the GPRS settings for each of the applications used over GPRS. Some service providers may have already set up information for your GPRS dial-up connection.

In order to use GPRS, you must first subscribe to the network service. Contact your service provider for details.

- 1 Select **Menu > Settings > Connectivity > GPRS > GPRS modem settings > Active access point** and the access point that you want to activate.



Settings

- 2 Select **Edit active access point** to change the access point settings.
Contact your service provider for the access point name.

You can also set the GPRS dial-up service settings (access point name) on your PC using the Nokia Modem Options software. See the Nokia PC Suite online help for more information. If you set the settings on both the phone and the PC, the PC settings will be used.

GPRS ICONS

The following icons appear in the upper left corner of the screen to show you the status of your GPRS connection.

-  Indicates an active GPRS connection (for example, when you are using the browser).
-  Indicates that the GPRS connection has been interrupted by a voice call or text message.

Data cable

- 1 Connect the DKU-2 data cable to the USB port on your computer and to the Pop-Port™ connector on your phone.
- 2 Start using the data communications application on the computer.
Making or answering phone calls during a computer connection is not recommended as it might disrupt the operation.

• Call settings

Call forwarding

Call forwarding tells your network to redirect incoming calls to another number. Call forwarding is a network service and may not work the same in all networks. Contact your service provider for more information.

ACTIVATE CALL FORWARDING

- 1 Select **Menu > Settings > Call settings > Call forwarding** and one of the following:
 - Forward all voice calls**—Forward all calls to the number you specify.
 - Forward if busy**—Forward all calls when you are in a call.
 - Forward if not answered**—Forward all calls to another number if you do not answer. You can also set a delay before forwarding takes place.
 - Forward if out of reach**—Forward all calls when your phone is turned off or out of the coverage area.
 - Forward if not available**—Forward all calls when you do not answer, your phone is busy or turned off, or out of the coverage area. You can also set a delay before forwarding takes place.

Forward all fax calls—Forward all fax calls to an alternate fax number.

Forward all data calls—Forward all data calls to a data mailbox.

Cancel all call forwarding—Cancel any call forwarding options you have set.

- 2 Select **Activate**; then select the destination to which your calls will be forwarded.
- 3 Enter the number to which your calls, data, or other information will be forwarded, and select **OK**; or select **Find** to retrieve a number from contacts.
- 4 If required, select the delay time before the call is forwarded.

Your phone calls the network to activate the feature you have requested. The network sends a confirmation note when the feature has been activated successfully.

CANCEL CALL FORWARDING

- 1 Select **Menu > Settings > Call settings > Call forwarding**.
- 2 Select **Cancel all call forwarding**; or one of the call forwarding options, and select **Cancel**.

Canceling all call forwarding may affect your ability to receive voice mail messages. Contact your service provider for specific details.

Anykey answer

Anykey answer allows you to answer an incoming call by briefly pressing any key except the **Power** key, the selection keys, and the **End** key.

Select **Menu > Settings > Call settings > Anykey answer > On or Off**.

Answer when fold is open

You can determine whether opening the fold automatically answers an incoming call.

Select **Menu > Settings > Call settings > Answer when fold is open > On or Off**.

Automatic redial

Occasionally, your network may experience heavy traffic, resulting in a *fast busy* signal when you dial. With automatic redial activated, your phone redials the number up to 10 times, and notifies you once the network is available.

Select **Menu > Settings > Call settings > Automatic redial > On or Off**.

1-touch dialing

You can turn the 1-touch dialing feature on and off. For more information, see "1-touch dialing" on page 38.

Select **Menu > Settings > Call settings > 1-touch dialing > On or Off**.

Call waiting

If supported by your service provider, call waiting notifies you of an incoming call even while you are in a call. You can accept, decline, or ignore the incoming call.

ACTIVATE OR DEACTIVATE

Select **Menu** > **Settings** > **Call settings** > **Call waiting** > **Activate** or **Cancel**.

CHECK STATUS

You can see whether call waiting is active, and for which type of calls.

Select **Menu** > **Settings** > **Call settings** > **Call waiting** > **Check status**.

USE CALL WAITING

- 1 During a call, press **Call** to answer the waiting call.
The first call is put on hold.
- 2 Press **End** to end the active call.

Summary after call

You can display the time spent on a call when you hang up (network service).

Select **Menu** > **Settings** > **Call settings** > **Summary after call** > **On** or **Off**.

Send my caller identity

You can prevent your number from being displayed on the receiving party's caller ID. This feature is a network service and works on a call-by-call basis. Contact your service provider for more information.

Select **Menu** > **Settings** > **Call settings** > **Send my caller ID** > **Set by network**, **Yes**, or **No**.

• Phone settings

Language

To set the language for the display texts, select **Menu** > **Settings** > **Phone settings** > **Language settings**. If you select **Automatic**, the phone selects the language according to the data in the SIM card.

Phone memory

You can check the amount of memory available in the phone. For more information, see "Shared memory" on page 3.

Select **Menu** > **Settings** > **Phone settings** > **Memory status**, and scroll through the list to view the memory associated with each item.

Security keyguard

You can set the phone to ask for the security code when you unlock the keyguard.

- 1 Select **Menu** > **Settings** > **Phone settings** > **Security keyguard**.
- 2 Enter the security code, and select **OK** > **On** or **Off**.

Welcome note

You can write a welcome note which shows up briefly on your display whenever you power up your phone. You must use standard text input for entering welcome note text. Press * to display and select from available special characters and smileys.

- 1 Select **Menu > Settings > Phone settings > Welcome note**.
- 2 Enter a note (up to 44 characters), and select **Save**.

System selection

You may be able to manually search for another network which has a roaming agreement with your home service provider.

Select **Menu > Settings > Phone settings > Operator selection** and one of the following:

Automatic—Your phone defaults to those settings which have been preset by your service provider.

Manual—Your phone searches for a network which has a roaming agreement with your service provider.

If **No system access** appears in the display, you need to switch to **Automatic** mode, or insert another SIM card into the phone.

Confirm SIM service actions

This option allows you to request notification when your service provider makes changes to SIM-related services (such as activating GPRS service).

Select **Menu > Settings > Phone settings > Confirm SIM service actions > Yes or No**.

Help text

For information about help text, see "In-phone help" on page 6.

• Enhancement settings

The **Enhancement settings** menu is shown only if the phone is or has been connected to one of the compatible enhancements such as the headset. Each compatible enhancement appears in the **Enhancement settings** menu only after it has been connected to the phone.

Select **Menu > Settings > Enhancement settings** and one of the available enhancements; then select the option of your choice and follow the prompts.

• Configuration settings

You can configure your phone with settings that are required for certain services to function correctly. The supported services are multimedia messaging, instant messaging, synchronization, streaming, and browser. Your service provider may also send you these settings. See "Connection settings service" on page 11.

For information on availability and the appropriate configuration settings, contact your network operator or service provider.

Select **Menu > Settings > Configuration settings** and one of the following:

Default configuration sett.—Scroll to a service provider, and select **Details** to view the services that the configuration settings of this service provider supports, or select **Options** and one of the following:

- **Set as default**—Set the configuration settings of the service provider as default settings.
- **Delete**—Delete the configuration settings.

Activate default in all applications—Activate the default configuration settings in all services.

Preferred access point—Scroll to an access point, and select **Options > Details** to view the name of the service provider, data bearer, and GPRS access point or GSM dial-up number.

Personal configuration settings—Add new personal accounts for various services, and activate or delete them. To add new configuration settings if you have not added any, select **Add new**; otherwise, select **Options > Add new**. Select the service type, and one by one select and key in all the required parameters. The parameters differ according to the selected service type. To delete or activate a personal account, scroll to it, and select **Options > Delete** or **Activate**.

• Security settings

Security features help to prevent accidental calls, allow you to restrict the calls your phone can make and receive, and keep your stored information safe.

PIN code request

The PIN code (4–8 digits) provides extra security in case your phone is lost or stolen. The PIN code must be obtained from your service provider. It is typically provided with your SIM card.

You can set your phone to request the PIN code upon power-up. After three successive incorrect entries the PIN code is blocked and you are asked to enter the personal unblocking key (PUK) code. Some SIM cards do not allow you to turn the PIN code request off.

- 1 Select **Menu > Settings > Security settings > PIN code request**.
- 2 At the prompt, enter the PIN code, and select **OK > On > OK**.

Call restrictions

This network service lets you restrict the calls your phone can make and receive. Check with your service provider for details.

When calls are restricted, calls may be possible to emergency numbers programmed into your phone (for example, 911). Enter the emergency number and press **Call**. The number appears in the display after you have keyed in the last digit.

TURN ON CALL RESTRICTIONS

- 1 Select **Menu > Settings > Security settings > Call restrictions** and one of the following:

Outgoing calls—Calls cannot be made.

International calls—Calls cannot be made to foreign countries.

Int. calls except to home country—When abroad, calls can be made only within the current country and to your home country (that is, the country where your home network operator is located).

Incoming calls—Calls cannot be received.

Incoming calls if roaming—Calls cannot be received outside your home area.

Cancel all call restrictions—Turns off all call restrictions. Calls can be made and received in the usual way. If you select this option, steps 2 and 3 are not available.

- 2 Scroll to one of the following options:

Activate—Enter the restriction password, and select **OK**.

Cancel—Enter the restriction password, and select **OK**. This option allows you to cancel one type of call restriction and leave others in force.

Check status—The phone lists the call types with call restriction active.

CHANGE YOUR RESTRICTION PASSWORD

Contact your service provider for your original restriction password.

- 1 From the menus, select **Settings > Security settings > Access codes > Change restriction password**.
- 2 Enter your current password, and select **OK**.
- 3 Enter your new password, and select **OK**.
- 4 Re-enter your new password for verification, and select **OK**.

Fixed dialing

Once you set up and activate a fixed dialing list, your phone can make calls only to those numbers that you have defined in the fixed dialing list. Fixed dialing is a network feature and must be supported by your service provider.

If you activate fixed dialing and the number list is empty, all outgoing calls, except for emergency numbers such as 911, require entry of the PIN2 code.

Settings

When fixed dialing is on, calls may be possible to emergency numbers programmed into your phone (for example, 911). Enter the emergency number and press **Call**. The number appears in the display after you have keyed in the last digit.

SET UP AND ACTIVATE A FIXED DIALING LIST

- 1 Select **Menu > Settings > Security Settings > Fixed dialing > Number list**.
Fixed dialing not active appears in the display followed by **Fixed dialing list empty**.
- 2 At the prompt, enter the PIN2 code, and select **OK**.
- 3 Enter the fixed dialing number, or select **Find** to retrieve a number from contacts, and select **OK**.
- 4 Enter a name for the number, and select **OK**.
- 5 Select **Back > On** to activate fixed dialing.

VIEW OR EDIT THE FIXED DIALING LIST

- 1 Select **Menu > Settings > Security Settings > Fixed dialing > Number list**.
- 2 At the prompt, enter the PIN2 code, and select **OK**.
- 3 Scroll to a number, and select **Options**, and an option from the list.

NOTES ABOUT FIXED DIALING

- If a SIM card with fixed dialing that is activated is inserted into a phone that does not support fixed dialing, the SIM card is rejected.
- When fixed dialing is on, GPRS connections are not possible except while sending text messages over a GPRS connection. In this case, the recipient's phone number and the message center number must be included in the fixed dialing list.
- You cannot access SIM memory manually (view or copy numbers on the SIM card) while fixed dialing is active.

Closed user groups

A closed user group is a network service that specifies the group of people whom you can call and who can call you. For more information, contact your service provider.

When calls are limited to closed user groups, calls may be possible to emergency numbers programmed into your phone (for example, 911). Enter the emergency number and press **Call**. The number appears in the display after you have keyed in the last digit.

- 1 Select **Menu > Settings > Security settings > Closed user group > On, Off, or Default**.
- 2 If you selected **On**, enter the group number provided by your service provider, and select **OK**.

Security levels

The security level determines your access to features when a non-owner SIM card is used. A non-owner SIM card is one (other than the original) that is inserted after you power off the phone. There are three security levels:

Off—Owner and non-owner cards are treated the same.

Memory—The phone will ask for the security code when the SIM card memory is selected and you want to change the memory in use or copy from one memory to another.

Phone—The security code is required whenever a new SIM card is inserted.

Use the following to set your security level.

- 1 Select **Menu > Settings > Security settings > Security level**.
- 2 At the prompt, enter the security code (default 12345), and select **OK > Off, Memory, or Phone**.

Access codes

SECURITY CODE

The security code (5–10 digits) controls access to features such as the security level and is supplied with the phone. The preset code is 12345.

If you enter the wrong security code five times in succession, you will not be able to enter a code for 5 minutes, even if you power off the phone between incorrect entries.

Once you change the security code from its preset of 12345, keep the new code secret and in a safe place separate from your phone. Use this procedure to change your security code.

- 1 Select **Menu > Settings > Security settings > Access codes > Change security code**.
- 2 At the prompt, enter the current security code (default 12345), and follow the prompts.

PIN CODE

Before you can change your PIN code (4–8 digits), you need to enable **PIN code request**. See "PIN code request" on page 51.

- 1 Select **Menu > Settings > Security settings > Access codes > Change PIN code**.
- 2 At the prompt, enter the current PIN code, and follow the prompts.

PIN2 CODE

The PIN2 code (4–8 digits) is required for features such as fixed dialing. If you enter an incorrect PIN2 code three times in succession, the PIN2 code is blocked and you will have to enter the PUK2 code.

The original PIN2 code must be obtained from your service provider.

Use this procedure to change your PIN2 code.

- 1 Select **Menu > Settings > Security settings > Access codes > Change PIN2 code**.
- 2 At the prompt, enter the current PIN2 code, and select **OK**.
- 3 At the prompt, enter the new PIN2 code, and select **OK**.
- 4 At the prompt, enter the new PIN2 code again, and select **OK**.

PUK AND PUK2 CODE

The PUK code is required to change a blocked PIN code. The PUK2 code is required to change a blocked PIN2 code. If the codes are not supplied with the SIM card, contact your service provider.

• Restore factory settings

You can reset some of the menu settings to their original values. However, data that you have entered or downloaded is not deleted. For example, names and numbers in contacts are not affected.

- 1 Select **Menu > Settings > Restore factory settings**.
- 2 Enter the security code (the default is 12345), and select **OK**.
A message confirms the original settings have been restored.

9 Gallery



You can save pictures, video clips, recordings, and ringing tones to folders in the gallery, and add new folders to the ones already there. You can download images and tones using MMS, mobile Internet sites, or Nokia PC Suite.

Your phone supports a digital rights management system to protect content that you have acquired. A piece of content, such as a ringing tone, can be protected and associated with certain usage rules, for example, the number of usage times or a certain usage period. The rules are defined in the content activation key that can be delivered with the content or separately, depending on the service provider. You may be able to update these activation keys. Always check the delivery terms of any content and activation key before acquiring them, as they may be subject to a fee.

Copyright protection may prevent some images, ringing tones, and other content from being copied, modified, transferred, or forwarded.

If the phone displays a message that the gallery memory is full, delete some gallery files before proceeding.

• Folders

- 1 Select **Menu > Gallery**.

A list of folders is displayed. **Images, Video clips, Themes, Graphics, Tones, and Recordings** are preset in the phone.

- 2 Scroll to a folder, and select **Open** to view a list of the files in the folder.
- 3 Select **Options** to view the available options.

Select **Activation key list** to list available activation keys. You can delete expired activation keys if desired.

Select **Downloads** to connect to the mobile Internet using your browser and the currently active set of gallery downloads. If the connection fails, you may need to activate another set or change the current settings. See "Set up for browsing" on page 75 for more information.

• Edit an image

- 1 Select **Menu > Gallery**, a folder that contains images, and **Open**.
- 2 Scroll to an image, and select **Options > Edit image > Options**.
Options include **Insert text, Insert frame, Insert clip-art, and Crop image**.

10 Media



• Camera

You can take photos and record video clips with the built-in camera, and adjust its settings. The camera lens is on the back of the phone, and the color display of the phone works as a viewfinder. The camera produces photos in JPEG format and video clips in H.263 (SubQCIF) format. After you have taken a picture or video, you can attach it to a multimedia message, and send it with MMS, save it as wallpaper in the start screen, save it in a compatible PC using Nokia PC Suite software, and upload it to a Web address with the content image uploader. When you attach a picture to an entry in your list of contacts, the picture is displayed when your contact calls you.

If there is not enough memory to take a new photo, free some by deleting old photos or other files in the gallery.

Take a photo

- 1 To open the camera from the start screen, scroll up; then scroll right and left to switch to portrait photo, night mode, or video

Standard photo—Lets you take a photo in landscape orientation under normal lighting conditions.

Portrait photo—Lets you take a photo in portrait orientation that can be added to a name or phone number saved in contacts.

Night mode—Lets you take a photo in landscape orientation in dim lighting. The live image appears on the display, and you can use the display as a viewfinder.

- 2 To use the self-timer, select **Options > Self-timer > Start**.
- 3 To take a photo immediately, select **Capture**.
The phone saves the photo in the **Images** folder of the **Gallery** menu.
- 4 Select **Back** to take another photo, **Delete** to delete the photo, or **Options** to access the options.

Record a video clip

- 1 Select **Menu > Media > Camera > Options > Change mode > Video**.
The live image appears in the display.
- 2 To start the video, select **Record**.
While you are recording,  and the remaining recording time are shown at the top of the display.
- 3 Select **Pause** to pause the recording and **Continue** to resume the recording.

- 4 Select **Stop** to stop the recording.
The phone saves the recording in the **Video clips** folder of the **Gallery** menu.
- 5 Select **Back** to record another video, **Play** to view the video, or **Options** to access the options.

Settings

You can select the level of image quality, turn camera sounds on and off, and define a default title to be used when you save a photo.

Select **Menu > Media > Camera > Options > Settings** and one of the following:

Image quality—Define file compression when saving the image. Select **High**, **Normal**, or **Basic**. **High** has the least file compression and provides the best image quality, but takes more memory.

Video clip length—Select **Default** or **Maximum**. The maximum is approximately 4 minutes depending on conditions. Only video clips that are default length or shorter can be sent in a multimedia message.

Camera sounds—Set the shutter and self-timer sounds to **On** or **Off**.

• Media player

With the media player you can download, view, and play compatible images, audio and video files, and animated images from a variety of sources.

The media player allows you to play streaming videos and streaming audio from a network server. Streaming functionality is a network service and requires network support. Check the availability of these services, pricing, and tariffs with your network operator or the service provider whose service you wish to use. Service providers will also give you instructions on how to use their services.

Select **Menu > Media > Media player** and one of the following:

Open Gallery—Open the gallery. From the gallery, you can play stored audio and video files. See "Gallery" on page 56.

Bookmarks—Open the list of bookmarks in the **Web** menu. See "Bookmarks" on page 77.

Go to address—Enter the address of a mobile Internet service, and select **OK**.

Media downloads—Download more graphics, tones, or videos to your phone. Download content only from sources you trust.

Streaming sett.—Set the connection settings for the media service.

Set up for a streaming service

For more information and for the appropriate settings, contact the network operator or service provider that offers the service that you want to use. You may receive the streaming settings as a connection settings message from the network operator or service provider that offers the service that you want to use. See "Connection settings service" on page 11.

Media

To add and edit the settings with Nokia PC Suite, see the Nokia PC Suite online help.

To enter the settings manually, select **Menu > Media > Media player > Streaming sett.** and each of the following:

Configuration—Select **Default** or **Personal config**, according to which configuration settings support streaming. See "Configuration settings" on page 51.

Account—Select a streaming account contained in the active configuration settings.

• Voice recorder

You can make a short recording (up to 3 minutes) and save it to the **Recordings** folder or another folder in the Gallery. You can set a recording as a ringing tone. You can also record your phone calls.

You cannot use the voice recorder when a data call or GPRS connection is active.

Make a recording

- 1 Select **Menu > Media > Voice recorder**.
- 2 To start the recording, select **Record**.
- 3 Hold the phone in the normal position near your ear, and record your message.
- 4 To stop the recording, select **Stop**.

The recording is saved in the **Recordings** folder of the Gallery.

- 5 To replay the latest recording, select **Play last recorded**.
- 6 To send the latest recording as a multimedia message or by IR mobile link to a compatible phone, select **Send last recorded**.

Record a phone call

During a call, select **Options > Record**. To stop recording, select **Stop**.

While the call is being recorded, all parties to the call can hear a faint beeping sound about every 5 seconds.

The recording is saved in the **Recordings** folder of the Gallery.

Manage recordings

- 1 Select **Menu > Media > Voice recorder > Recordings list**.
- 2 Scroll to the **Recordings** folder or the folder that you have defined for storing recordings, and select **Open**.
- 3 Use the options available in the Gallery.

11 Organizer



• Alarm clock

The alarm clock is based on the internal clock of your phone. It sounds an alert at the time you specify. The alarm works even if the fold is closed or if the phone is off, as long as there is enough power in the battery. When the alarm is triggered, the alarm stays on until it is turned off.

Select an alarm tone

Select **Menu > Organizer > Alarm clock > Alarm tone** and one of the following:

Standard—Select the default alarm tone.

Ringtone—Select an alarm tone from the ringing tone list.

Open Gallery—Select a sound clip from a gallery folder to use as an alarm. Open a folder that contains tones, scroll to the tone you want, and select **Options > Select**.

Set an alarm

- 1 Select **Menu > Organizer > Alarm clock > Alarm time**.
- 2 If the alarm is already set, select **On**.
- 3 Enter the time for the alarm in *hh:mm* format, and select **OK > am** or **pm**.
Alarm on appears briefly in the display, and  appears on the start screen.

Repeat alarm

You can set the alarm clock to alert you on selected days of the week.

- 1 Select **Menu > Organizer > Alarm clock > Repeat alarm > Repetition days**.
- 2 Scroll to each desired day, and select **Mark**; or to mark all days, select **Options > Mark all**.
- 3 When you are finished, select **Done**.

Turn off an alarm setting

Select **Menu > Organizer > Alarm clock > Alarm time > Off**.

When the alarm sounds

WITH THE PHONE ON

The phone sounds an alert tone, flashes **Alarm!**, and shows the current time.

Select **Stop** to shut the alarm off, or select **Snooze** to stop the alarm for 10 minutes.

If the fold is closed, press either of the volume keys to set the alarm to snooze.

WITH THE PHONE OFF

If the alarm time is reached while the device is switched off, the device switches itself on and starts sounding the alarm tone. If you select **Stop**, the device asks whether you want to activate the device for calls. Select **No** to turn off the device or **Yes** to make and receive calls. Do not select **Yes** when wireless phone use may cause interference or danger.

• Calendar

The calendar keeps track of reminders, calls you need to make, meetings, and birthdays. It can even sound an alarm for any of these events.

Open the calendar

Select **Menu > Organizer > Calendar**.

The month view of the calendar appears in the display with the current date highlighted. You can move to another date by using the four-way scroll keys like a joystick.

The month view provides an overview of the selected month and weeks. It also allows you to jump to a specific date. Any days or dates that appear in bold font contain calendar notes such as a meeting or reminder.

While in the month view, to display the week view, select **Options > Week view**.

Settings

In either the month view or the week view, select **Options > Settings**, and one of the listed options, and follow the prompts.

You can set the phone to delete calendar notes automatically after a day, a week, or a month, or to never delete notes. Even if you set the phone for automatic deletion, repeating notes such as birthdays are not deleted.

Go to a date

- 1 In either the month view or the week view, select **Options > Go to date**.
- 2 Enter the date (for example, 01/05/2004), and select **OK**.

The month or week view appears in the display with the jump date highlighted.

Make a note

You can choose from five types of notes: **Meeting**, **Call**, **Birthday**, **Memo**, and **Reminder**. Your phone asks for further information depending on which note you choose. You can also set an alarm, with or without an alarm tone, for any note.

- 1 Go to the date for which you want to make a note, and select **Options > Make a note** and one of the listed types of notes.
- 2 Enter the information requested by the prompts.

View notes

Any dates that contain calendar notes are in bold (in the month view) or display a note icon (in the week view).

- 1 Go to the date containing the note, and select **View**.
The headers of any notes you have for the day appear in a list format.
- 2 Scroll to the desired note, and select **View**.
The body of the note appears in the display.

Note options

While viewing the header or the body of a note, select **Options** and one of the following:

Make a note, Delete, Edit, Move, Go to date, Copy, Go to to-do list

Repeat—Make the note recur on a regular basis (daily, weekly, biweekly, monthly, and yearly).

Send note—Send the note to another device using IR mobile link, as a text or multimedia message or as a note to another compatible phone calendar.

Settings—Set the date and time, date and time format, the day each week starts, and whether you want your notes to autodelete after a specified time.

Note alarms

The phone beeps and displays the note. When a call note is displayed, you can call the displayed number by pressing **Call**.

To stop the alarm without viewing the note, select **Exit**.

To stop the alarm and view the note, select **View**. Select **Snooze**; the phone returns to the start screen and sounds an alarm again after 10 minutes.

If the fold is closed, press either of the volume keys to mute the note alarm.

Send a note

- 1 Go to the date with the note you want to send, select **View**, and the note.
- 2 Select **Options > Send note > Via calendar, Via multimedia, Via text message, or Via Infrared**.
- 3 Follow the prompts to send the note.

Receive notes

When you receive a calendar note, your phone displays **Calendar note received**. You can then save the note in your calendar if desired, and set an alarm for any date and time.

- 1 When your phone displays **Calendar note received**, select **Show**; then use the scroll keys to view the entire message, if necessary.
- 2 To save the calendar note, select **Options > Save**, or to discard the calendar note, select **Options > Discard**.

• To-do list

Use the to-do list feature to keep track of your tasks. You can save a note for a task, select a priority level for the note, and mark it as done when you have completed it. You can sort the notes by priority or by date.

Add a note

- 1 Select **Menu > Organizer > To-do list**.
- 2 If there are no notes, select **Add note**; if there are notes, select **Options > Add**.
- 3 Enter the subject of the to-do note, and select **Save**.
- 4 Select either **High**, **Medium**, or **Low** priority.

The to-do note is saved. The phone automatically sets the deadline without an alarm.

View a note

Select **Menu > Organizer > To-do list**, scroll to a to-do note, and select **View**.

Options while viewing notes

Select **Options** while viewing the header or body of a particular note and the following options appear:

Add, **Deadline**, **Delete**, **Sort by deadline**, **Go to calendar**, **Save to calendar**, **Delete all notes**.

Mark note as done—Mark a note or task as complete; no more reminders will follow.

Send—Send the note to another device using IR, as a text or multimedia message, or as a calendar note to another compatible phone.

Edit priority—Change the priority to high, medium, or low (available only in body view).

• Notes

You can use the notes application to write and send notes to compatible devices using IR or as a text message or multimedia message.

Make a note

- 1 Select **Menu > Organizer > Notes**.
- 2 If there are no notes, select **Add note**; or if there are notes, select **Options > Make a note**.
- 3 Enter the text of the note.
- 4 While entering text, select **Options**, and follow the prompts.

Send a note

- 1 Highlight the note you want to send, and select **Options > Send note > Via infrared, Via text message, or Via multimedia.**
- 2 Follow the prompts to send the note.

• Synchronization

The phone synchronization feature is a network service that allows you to synchronize the calendar and contacts in your phone with a remote Internet server or a compatible PC. If you have saved data in the remote Internet server, you can synchronize your phone by starting the synchronization from the phone. You can also synchronize your phone contacts and calendar to correspond with the data of a compatible PC by starting the synchronization from the PC. You must install Nokia PC Suite on your PC to use this feature. See "Nokia PC Suite" on page 11 for more information.

Contacts in your SIM card will not be synchronized.

Answering an incoming call during synchronization will end synchronization and you will need to restart it.

This feature must be supported by your service provider. For more information on availability and synchronization service settings, contact your service provider.

Save settings

You may receive the synchronization settings as a settings message or you may need to enter the synchronization settings manually.

SAVE SETTINGS RECEIVED AS A SETTINGS MESSAGE

When you receive the synchronization settings as a settings message, **Synchronization settings received** is displayed.

Select **Options > Details, Save, or Discard.**

SAVE SETTINGS MANUALLY

You need to activate the set where you want to save the synchronization settings. A set is a collection of settings required to make a connection to a service. Contact your service provider for the settings.

- 1 Select **Menu > Organizer > Synchronization > Server sync > Sync settings** and the following:

Configuration—Select **Default** or **Personal config.** depending on which configuration settings support the synchronization. See "Configuration settings" on page 51.

Account—Select a service account contained in the active configuration settings.

- 2 Select **PC sync. settings** and the following:
 - User name**—Enter the user name, and select **OK**. (Contact your service provider, if necessary, for this information.)
 - Password**—Enter the password, and select **OK**. (Contact your service provider, if necessary, for this information.)

The user name and password must be the same in the phone and in the PC.

With a remote Internet server

If you have saved data in the remote Internet server, you can synchronize your phone by starting the synchronization from your phone. Once you have customized and selected the appropriate synchronization settings, you are ready to synchronize data. (See "Save settings" on page 64 or "Save settings manually" on page 64 for more information.)

SYNCHRONIZE DATA

- 1 Select **Menu > Organizer > Synchronization > Server sync > Data to be synchronized**.
 - 2 Mark the data to be synchronized.
 - 3 Select **Menu > Organizer > Synchronization > Server sync > Synchronize**. Synchronization begins.
- Depending on the type of connection you are using to synchronize data, connecting or initializing messages may appear.

Synchronizing for the first time or after an interrupted synchronization may take up to 30 minutes, if contacts or calendar are full.

STOP SYNCHRONIZATION

- 1 To stop synchronization, select **End call**, or press **End**.
- 2 At the **Quit synchronization?** prompt, select **OK**.

HANDLE CALLS DURING SYNCHRONIZATION

During synchronization, outgoing calls are not possible. Incoming calls can still be received, and can be handled in one of the following ways:

- To decline the incoming call, press **End**. Synchronization continues.
- To answer the incoming call, press **Call**. Synchronization is interrupted and a **Synchronization suspended** message appears.

Once the incoming call is ended, a **Start synchronization again?** message appears. Select **Yes** to start synchronization again from the beginning.

With your PC

You can synchronize the data in contacts and calendar to correspond with the data of your PC by starting the synchronization from your PC. To synchronize data from your PC, use either an IR connection or a data cable. You also need the Nokia PC Suite software installed on your PC.

Start the synchronization from your PC using Nokia PC suite. For more information, see the Nokia PC Suite online help. After synchronizing, the data in the phone and in the PC are the same.

• Wallet

The wallet feature allows you to store personal information like debit and credit card information to an encrypted area of phone memory. This information can then be used to make secure online purchases. Wallet purchases can also use digital signatures enabled by a security module in the SIM card (if present) for signing and verifying transactions. Online purchases and digital signature capabilities depend on your service provider.

You can also store personal information such as PIN codes and other sensitive data in a wallet personal note.

You must enter a wallet code each time you access wallet. If you do not use wallet for 5 minutes, it is automatically closed.

Create a code

The first time you access wallet, you must create a personalized wallet code.

- 1 Select **Menu > Organizer > Wallet**.
- 2 At the prompt, enter the 4–10 digit code of your choice, and select **OK**.
- 3 Enter the same code again for verification, and select **OK**.

Create a code that is unique, yet easy to remember. This will be your key to using wallet features in the future. Also, keep your wallet code in a secret place, separate from your phone.

If you enter an incorrect wallet code three times in succession, you cannot access wallet for 5 minutes.

Change the code

- 1 Select **Menu > Organizer > Wallet**.
- 2 At the prompt, enter your wallet code, and select **OK > Settings > Change code**.
- 3 Enter the original wallet code, and select **OK**.
- 4 Enter the new wallet code, and select **OK**.
- 5 Enter the new wallet code again for verification, and select **OK**.

Reset the code

If you forget your wallet code, you can reset the code and to erase all the information stored in wallet.

Once you reset the wallet code and clear the contents of wallet, all of the information is deleted. You must manually enter the information to restore it.

- 1 At the start screen, enter ***#7370925538# (#res wallet#)**.

- 2 At the prompt, select **Yes**.
- 3 Enter your security code, and select **OK**.

Wallet menu

- 1 Select **Menu > Organizer > Wallet**.
- 2 At the prompt, enter your wallet code, and select **OK** and one of the following:
 - Wallet profiles**—Create card combinations for different services.
 - Cards**—Save personal card information. See “Create a card” on page 67.
 - Tickets**—Save notifications of e-tickets that you have bought through a mobile service.
 - Receipts**—Save receipts for mobile purchases.
 - Personal notes**—Save any personal information that you want to protect with the wallet code.
 - Settings**—Set and change the wallet settings.
 - **Change code**—Change the wallet code.
 - **RFID**—Set the radio frequency identification (RFID) code. The RFID technology helps to securely conduct commerce transactions with your phone. You can enter the **RFID code** and the **RFID type**.

Create a card

Wallet supports several categories of cards.

- 1 Access the wallet, and select **Cards** and one of the following:
 - Payment cards**—Credit and debit cards
 - Loyalty cards**—Membership cards
 - Access cards**—Personal user names and passwords to online services
 - User info cards**—Customized personal preferences for online services
 - Address cards**—Contact information such as delivery and billing addresses
- 2 If there are no cards in that category, select **Add new**; if there are cards, select **Options > Add new** and follow the prompts.
- 3 When you are finished, select **Done**.

If supported by your service provider, you can also receive card information as a message. You are notified which category the card belongs to. Save or discard the received card. You can view and rename the saved card, but you cannot edit it. Contact your service provider for more information.

Compose a personal note

Wallet can store up to 30 personal notes, such as passcodes or other sensitive data. Your notes are protected by the wallet security feature.

- 1 Access the wallet, and select **Personal notes**.

- 2 If there are no notes in the list, select **Add new**; if there are notes in the list, select **Options > Add new**.
- 3 Compose your note, and select **OK**.
- 4 Enter a title for the note, and select **OK**.

Note options

While viewing note headers, select **View** to view the contents of the selected note, or select **Options > Edit, Add new, Sort, Delete, or Delete all**.

While viewing the contents of a note, select **Edit** to edit the note, or select **Options > Send via text msg., Copy to calendar, Use detail, or Delete**.

Create a wallet profile

When you have saved your personal card details, you can combine them into a wallet profile. You can use the profile to retrieve wallet data from different cards while browsing.

- 1 Access the wallet, and select **Wallet profiles**.
- 2 If there are no wallet profiles, select **Add new**; if there are wallet profiles, select **Options > Add new**.
- 3 Follow the prompts to select a payment card, a loyalty card list, an access card, a user info card, a billing address, a shipping address, a receipt delivery address, and a receipt delivery method (either **To phone number** or **To e-mail address**).
- 4 At the **Wallet profile name** prompt, enter a name for the profile, and select **OK**.

Purchase guidelines

To shop, access the desired service site that supports wallet. See "Mobile Internet services" on page 75. The service must support the Electronic Commerce Modeling Language specification.

Choose the product you want to buy and read all information carefully.

When you indicate that you want to buy an item, the phone asks whether you want to use wallet, and asks for your wallet code.

Select the card you want to use from the payment cards list. The phone automatically fills in the credit card information or the wallet profile.

Approve the purchase, and the information is forwarded. You may receive an acknowledgement or a digital receipt.

To close the wallet, select **Close wallet**.

If you have accessed or tried to access confidential information requiring passwords, such as a bank account, empty the phone cache after each use. See "Cache memory" on page 80.

• Calculator

Basic calculations

The calculator adds, subtracts, multiplies, divides, calculates the square and the square root, and converts currency values.



Note: This calculator has limited accuracy and is designed for simple calculations.

- 1 Select **Menu > Organizer > Calculator**.
- 2 In the calculator screen, enter the first number in the calculation.
Press **#** for a decimal point if necessary.
- 3 To perform an arithmetic calculation, press ***** to cycle through the add (+), subtract (-), multiply (*), and divide (/) characters, and pause briefly to select the displayed character; then enter the second number in your calculation, and select **Equals**.
- 4 To perform a square or square root calculation, select **Options > Square or Square root**.

The completed calculation appears in the display.

Currency conversion

You can convert foreign currency to home currency, or vice versa.

CREATE OR EDIT THE EXCHANGE RATE

- 1 Select **Menu > Organizer > Calculator > Options > Exchange rate** and one of the following:
 - Foreign units in home units**—Enter the number of home units it takes to make one unit of foreign currency.
 - Home units in foreign units**—Enter the number of foreign units it takes to make one unit of your home currency.
- 2 Enter the exchange rate, and select **OK**.

CONVERT CURRENCY

- 1 Perform the currency conversion directly from the start screen, or select **Menu > Organizer > Calculator**.
- 2 Enter amount of currency to convert, select **Options**, and one of the following:
 - To home**—Converts foreign currency to domestic currency.
 - To foreign**—Converts domestic currency to foreign currency.

The converted amount appears in the display.

• Stopwatch

Your phone has a stopwatch that can be used to track time at sporting events or other occasions. While the stopwatch is running, if you press **End** and return to the start screen, the clock continues to run in the background, and  appears in the upper left corner of the screen.

Using the stopwatch consumes the battery and reduces the operating time of the phone. Be careful not to let it run in the background when performing other operations with your phone.

Measure split time

You can use the split time function for such things as a long distance race when you need to pace yourself.

- 1 Select **Menu > Organizer > Stopwatch > Split timing > Start**.
- 2 To take an intermediate time, select **Split**.

The timer continues to run. The split time appears below the running time.

If you split the time more than once, the new measured time appears at the beginning of the list. You can scroll to see previous measured times.

- 3 To stop timing, select **Stop**.

The total time appears at the top of the display.

Measure lap time

You can use the lap time function when you want to track how long it takes to complete each cycle or lap.

- 1 Select **Menu > Organizer > Stopwatch > Lap timing > Start**.

The running time appears on the screen.

- 2 Select **Lap** to measure lap time.

The clock stops, then starts immediately from zero. The lap time appears below the running time.

If you take more than one lap time, the new measured time appears at the beginning of the list. You can scroll to see previous measured times.

- 3 To stop timing, select **Stop**.

The total time appears at the top of the display.

Save the time

- 1 While the clock is running, select **Stop > Save**.
- 2 Enter a name for the measurement, and select **OK**.

If you do not enter a name, the total time is used as the default title for the lap time.

• Countdown timer

The countdown timer is like an egg-timer or the timer on your microwave oven. You can enter a specified time (up to 99 hours and 59 minutes), and when the time runs out, your phone sounds an alarm. The countdown timer only works when the phone is on. Once you turn off your phone, the countdown timer is no longer active.

Set the countdown timer

- 1 Select **Menu > Organizer > Countdown timer**.
- 2 At the prompt, enter the time in *hh:mm:ss* format, and select **OK**.
- 3 Enter a note for the countdown timer, and select **Start**.

The countdown timer begins running. The  icon appears in the upper left corner of the start screen.

Change the time

After you have set the countdown timer, you can change the time.

- 1 Select **Menu > Organizer > Countdown timer > Change time**.
- 2 Enter the new time in *hh:mm:ss* format, and select **OK**.

The countdown timer begins running.

Countdown timer alarm

When the time runs out, your phone sounds an alarm and displays the timer note or **Countdown completed**.

To stop the countdown timer, press any key during the alarm. To stop the alarm and delete the text note, select **Exit**.

If you do not respond to the countdown timer alert, it expires automatically after 30 seconds.

Stop the countdown timer

Select **Menu > Organizer > Countdown timer > Stop timer**.

Timer stopped appears in the display.

12 Applications



Your phone supports J2ME™ Java applications. You will find some Java applications and games pre-installed on your phone. Also, you can manage and download new applications and games from your service provider. Running some applications and games may consume the battery faster. You may need to connect the phone to the charger.

• Games

Start a game

- 1 Select **Menu** > **Applications** > **Games** > **Select game**, a game, and **Open**.
- 2 To begin a new game, select **New game**.
- 3 To read the games rules, select **Instructions**.

Options

While viewing the games list, select **Options** to display the following options:

Delete—Delete the game.

Details—Display details of the game.

Update version—Check if a new version of the game is available for download.

Web page—Get more information or additional data from a mobile Internet page. This feature is shown only if it is supported by the network and a mobile Internet address has been provided by the game.

App. access—Choose whether the game should be allowed to access the network. You can require that the game ask every time it tries to access the network, ask only the first time, always access the network without asking, or never access the network.

Downloads

Your phone supports J2ME Java applications. During downloading the compatibility is checked, and the downloading is interrupted if the phone does not support the application.

- 1 Select **Menu** > **Applications** > **Games** > **Game downloads** and one of the bookmarks displayed.
To access the list of bookmarks in the **Web** menu, select **More bookmarks**.
- 2 Select **Select**.
The phone connects to the Web pages using the currently active set of browser settings. If the connection fails, you may enter the **Web** menu and activate another set of service settings. See "Set up for browsing" on page 75.

When downloading a game, it may be saved in the **Collection** menu instead of the **Games** menu.

Settings

You can turn game sounds, lights, and vibration on or off.

- 1 Select **Menu > Applications > Games > App. settings.**
- 2 Select **Application sounds** or **Application shakes > On** or **Off**; or select **Application lights > App. defined** or **Default.**

• Collection

Start an application

- 1 Select **Menu > Applications > Collection > Select application.**
- 2 Scroll to an application or an application set, and select **Open.**
If the selection is a single application, the application starts. Otherwise, a list of applications within the selected application set appears in the display.
- 3 To start a single application, scroll to the desired application, and select **Open.**

Options

While viewing the application list, select **Options** to display the following options.

Delete—Delete the application or application set from your phone. If you delete a pre-installed application or application set, you may be able to download it again from www.nokia.com/us.

Details—Shows additional information about the application.

Update version—Check if a new version of the application is available for download.

Web page—Get further information or additional data for the application from a mobile Internet page. This feature must be supported by a service provider. It is only shown if a mobile Internet address has been provided with the application.

App. access—Choose whether the application should be allowed to access the network. You can require that the application ask every time it tries to access the network, ask only the first time, always access the network without asking, or never access the network.

Downloads



Note: Only install sources that offer adequate protection against harmful software. Downloading applications is a network service. Contact your service provider for more information

Your phone supports J2ME Java applications. During downloading the compatibility is checked, and the downloading is interrupted if the phone does not support the application.

When you download games or applications, games may be saved in the **Collection** menu and applications may be saved in the **Games** menu.



APPLICATIONS

- 1 Select **Menu > Applications > Collection > App. downloads.**

A list of available browser bookmarks appears in the display.

- 2 Select **More bookmarks** to access the list of browser bookmarks in your **Web** menu.

- 3 Select the bookmark that contains the application you wish to download.

The phone connects to the Web page. See "Navigate the mobile Internet" on page 76 for information on browsing Web pages. If the connection fails, you may enter the **Web** menu and activate another set of service settings. See "Set up for browsing" on page 75.

LINKS

Select **Menu > Web > Download links > App. downloads** and one of the sites from the list.

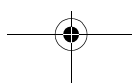
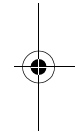
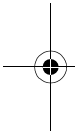

13 Mobile Internet services



The browser on your phone can display content that uses wireless mark-up language (WML) or extensible hypertext mark-up language (XHTML). The browser supports WAP 2.0 protocols (HTTP and SSL) that run on TCP and IP protocols.

This feature is a network service. Contact your service provider for more information.

Because mobile Internet content is designed to be viewed from your phone, your service provider is now your mobile Internet service provider as well.

It is likely that your service provider has created a home page and set up your browser to go to this page when you log on to the mobile Internet. Once at your service provider's home page, you may find links to a number of other sites.

• Set up for browsing

It may not be necessary to manually configure the browser on your phone if this was done by your service provider when you subscribed to the feature.

You may receive the service settings as a connection settings message from your service provider. See "Connection settings service" on page 11.

You can enter the settings manually or add and edit the settings with Nokia PC Suite.

To enter the settings manually, select **Menu > Web > Settings > Configuration settings** and each of the following:

Configuration—Select **Default** or **Personal config**, depending on which configuration settings support the service. See "Configuration settings" on page 51.

Account—Select a service account contained in the active configuration settings.

Display terminal window—Select **Yes** to perform manual user authentication for intranet connections.

Contact your service provider if you have problems using the browser.

Activate service settings



Select **Menu > Web > Settings > Configuration settings > Active service settings**, scroll to the desired service, and select **Activate**.

Connect to the web

To open the web start page, at the start screen, press and hold **0** (the Internet icon .

To select a bookmark, select **Menu > Web > Bookmarks**, and a bookmark from the list. If the bookmark does not work with the current active service settings, activate another set of service settings and try again.

After a brief pause, the phone attempts to connect to your service provider's home page or to the address that you selected.

If you see **Check service settings**, the phone may not be set up for browsing. Contact your service provider to make sure that your phone is configured properly. If GPRS is selected as the data bearer,  is shown in the upper left corner of the display during browsing. If you make a call or receive a call or text message, the GPRS connection is suspended and  is shown in the upper right corner of the display. After the call, the phone tries to reestablish the GPRS connection.

Navigate the mobile Internet

Since your phone screen is much smaller than a computer screen, mobile Internet content is displayed differently from content displayed on a computer. This section contains guidelines for using phone keys to navigate a mobile Internet site.

- To browse the site, use any of the scroll keys.
- To select a highlighted item, press **Call** or select **Open**.
- To enter letters and numbers, press a key from **0-9**.
- To enter special characters, press *****.

Examples of elements you may find on a mobile Internet site are as follows:

Header line. Shows the current mobile Internet site.

Active link. Appears as a highlighted word.

Inactive link. Appears as an underlined word.

Scroll up and down through the list of links.

Options. Select **Options** to go to the list of service options. See "Options while online" on page 79.

Select. Select **Select** to go to the active link.

Back. Select **Back** to return to the previous page.

Appearance settings

You can determine how pages appear on the phone display.

- 1 Select **Menu > Web > Settings > Appearance settings**; or while browsing, select **Options > Other options > Appear. settings**.
- 2 Select one of the following options:
 - Text wrapping**—Text on the Web page continues on the next line if it cannot be shown on only one line. Select **On** to allow text wrapping, or **Off** to prevent text wrapping.
 - Font size**—Select **Small**, **Normal**, or **Large**.
 - Show images**—Select **Yes** to display pictures from the page or **No** to hide pictures. When pictures are displayed, pages load more slowly.
 - Alerts**—The phone can alert you to unsecure connections and to unsecure items on secure pages. However, these alerts do not guarantee a secure connection.

Mobile Internet services

- **Alert for unsecure connection**—Select **Yes** to set the phone to alert you when a secure connection changes to an unsecure connection during browsing.
- **Alert for unsecure items**—Select **Yes** to set the phone to alert you when a secure page contains an unsecure item.

Character encoding—Select encoding methods for Web content and Web addresses.

- **Content encoding**—Select the character set that the phone uses to display browser pages that do not include that information.
- **Unicode (UTF-8) web addresses**—Determine whether to always use UTF-8 encoding when sending a Web address to a compatible phone. Select **On** or **Off**.

Bookmarks

You can save addresses for your favorite sites as bookmarks.

Your device may have some bookmarks loaded for sites not affiliated with Nokia. Nokia does not warrant or endorse these sites. If you choose to access them, you should take the same precautions, for security or content, as you would with any mobile Internet site.

SET MANUALLY

- 1 Select **Menu > Web > Bookmarks**.
- 2 If there are no bookmarks in the list, select **Add new**; or if there are bookmarks in the list, select **Options > New bookmark**.
- 3 Enter an address for the bookmark, and select **OK**.
- 4 Enter a title for the bookmark, and select **OK**.

SET WHILE ONLINE

While you are connected to the site that you want to bookmark, select **Options > Add bookmark**.

RECEIVE

When you receive a bookmark, **1 bookmark received** is displayed. Select **Show > Save** to save the bookmark, or **Options > View** or **Delete** to view or delete it.

• Service inbox

You can receive service messages (pushed messages) from your service provider.

Message settings

Select **Menu > Web > Settings > Service inbox settings** and one of the following:

Service messages—Select **On** to receive service messages, or **Off** to reject them.

Message filter—Select **On** to set the phone to receive messages only from content authors approved by the service provider. Select **Trusted channels** to view the list of approved content authors.

Automatic connection—Select **On** to automatically activate the browser from the start screen when a service message is received; or **Off** to activate the browser only when you select **Retrieve** after a service message is received.

View a message

When you receive a service message, a note appears in the display. To view the message:

- 1 At the start screen, select **Show** to view the message immediately, or **Exit** to save it to the service inbox for later viewing.
- 2 While browsing, select **Options > Other options > Service inbox**.

To view a saved service message:

- 1 Select **Menu > Web > Service inbox**.
- 2 Scroll to the desired message, and select **Options** and one of the following:
 - Retrieve**—Activate the browser, and download the content indicated in the message.
 - Details**—View the details of the message.
 - Delete**—Delete the message.

• File download

You can download tones, images, games, and applications from the mobile Internet.

- 1 Select **Menu > Web > Download links**; or while browsing, select **Options > Download links**.
- 2 Select a download option; then select one of the sites from the list and follow the prompts.

• Disconnect from the mobile Internet

To close your connection, press and hold **End**.

• Emergency call while online

If you are using GPRS to connect to the mobile Internet, you can end your data connection and then make an emergency call.

- 1 To close your mobile Internet connection, press **End** twice.
- 2 Enter the emergency number (for example, 911), and press **Call**.

• Options while online

While you are connected to the mobile Internet, select **Options** to access the following options. Some service providers may have customized these options. Contact your service provider for more information if any of the following options are not available.

Use wallet info—Use the wallet card information from the wallet application, if the service page supports wallet. See "Wallet" on page 66.

Shortcuts—Open a new list of options, such as options specific to the current page.

Home—Go to the service home page.

Add bookmark—Saves the current page as a bookmark.

Bookmarks—Shows a list of all saved bookmarks. Bookmarks help you find a mobile Internet site quickly.

Download links—Show the list of bookmarks for downloading tones, graphics, games, or applications.

Save to folder—Add a bookmark for the current site to the list of bookmarks for downloading tones, graphics, games, videos, or applications. The bookmark then appears in the appropriate folder in the **Download links** submenu.

Other options—Show a list of other options, such as appearance and security options.

Reload—Reload and update the current page.

End call—Disconnect from a service.

The browser supports functions that you can access while browsing. You can make a voice call, send touch tones while a voice call is in progress, and save a name and phone number from a page.

• Security

Security features may be required for some services, such as banking or shopping. For such connections you need security certificates and possibly a security module which may be available on your SIM card. For more information, contact your service provider.

Security module

The security module improves security services and allows you to use a digital signature. It can contain certificates and public and private keys. Your service provider saves the certificates in the security module.

Select **Menu > Web > Settings > Security settings > Security module settings** and one of the following:

Security module details—View the security module title, status, manufacturer, and serial number.

Module PIN request—Select **On** to set the phone to ask for the module PIN when using services provided by the security module.

Change module PIN—Change the module PIN, if allowed by the security module.

Change signing PIN—Select and change a signing PIN.

Digital signature

You can make digital signatures with your phone if your SIM card has a security module. The signature can be traced back to you through the private key on the security module and the user certificate that was used to perform the signature. Using the digital signature can be the same as signing your name to a paper bill, contract, or other document.

- 1 While browsing, select a link on a page, such as the title of the book you want to buy and its price.

The text to sign (possibly including amount, date, etc.) is shown.

- 2 Check that the header text is **Read** and that the digital signature icon  is shown.

If the digital signature icon does not appear, there is a security breach. Do not enter any personal data such as your signing PIN.

- 3 Scroll through and read *all* of the text before signing.
- 4 To sign the text, select **Sign**.
- 5 Select the user certificate you want to use, enter the signing PIN (provided with the SIM card if the SIM card has a security module), and select **OK**.

The digital signature icon disappears, and the service may display a confirmation of your purchase.

Cache memory

The information or services you access with the browser are temporarily saved in the cache memory of the phone.

If you tried to access or have accessed confidential information requiring passwords (for example, your bank account), clear the cache after each use.

To clear the cache from the menu, select **Web > Clear the cache**.

To clear the cache while browsing, select **Options > Other options > Clear the cache**.

Certificates

There are three kinds of certificates: server, authority, and user.

Certificates have a restricted lifetime. If **Expired certificate** or **Certificate not valid yet** is shown even though the certificate should be valid, check that the current date and time settings in your phone are correct. Before changing these settings, make sure that you really trust the owner of the certificate and that the certificate really belongs to the listed owner.

SERVER CERTIFICATES

The phone uses a server certificate to create a connection with improved security between the phone and the content server. The phone receives the server certificate from the service provider before the connection is established. The validity of the server certificate is checked using the authority certificates saved in the phone. Server certificates are not saved.

AUTHORITY CERTIFICATES

Authority certificates are used by some services, such as banking, for checking the validity of other certificates. Authority certificates can be saved in the security module by the service provider, or they can be downloaded from the network if the service supports the use of authority certificates.

To view authority certificates, select **Web > Settings > Security settings > Authority certificates > Certificate list**, scroll to the desired certificate, and select **View**.

USER CERTIFICATES

User certificates are issued to users by a certifying authority. User certificates are required to make a digital signature. They associate the user with a specific private key in a security module.

To view user certificates, select **Web > Settings > Security settings > User certificates > Certificate list**, scroll to the desired certificate, and select **View**.

Cookies

A cookie is data that a Web site saves in your phone browser cache memory. The data can be, for example, your user information or your browsing preferences. Cookies will be saved until you clear the cache memory.

- 1 Select **Menu > Web > Settings > Security settings > Cookies**; or while browsing, select **Options > Other options > Security > Cookie settings**.
- 2 Select **Allow** to accept cookies or **Reject** to reject cookies.

Scripts over secure connection

To allow scripts from a secure page to be run, do one of the following:

- In the start screen, select **Menu > Web > Settings > Security settings > Scripts over secure connection > Allow**.
- While browsing, select **Options > Other options > Security > Script settings > Allow**.

14 SIM services



In addition to the functions available on the phone, your SIM card may provide additional services that you can access through the SIM services menu. This menu is shown only if it is supported by your SIM card. The name and contents of the menu depend entirely on the service available. For availability, rates, and information on using SIM services, contact your service provider.

To see the messages sent between the phone and the network when you are using the SIM services, select **Menu > Settings > Phone settings > Confirm SIM service actions > Yes**.

Accessing these services may involve sending a text message or making a phone call for which you may be charged.

15 Hardware and enhancements

• Hardware

Connection ports and other features

For the location of ports and other features of your phone, refer to "Phone introduction—fold closed" on page 6, and "Phone introduction—fold open" on page 7.

The BL-4C battery provides up to 4 hours of talk time and up to 270 hours of standby time. Operation times are estimates and may vary depending on network conditions, charging, and use of various features.

• Enhancements

Your phone is compatible with the following Nokia mobile enhancements:

Power

- 760-mAh Li-Ion battery (BL-4C)
- Retractable travel charger (AC-1)
- Travel charger (ACP-12)
- Mobile charger (ACP-7)
- Mobile charger (LCH-12)

Data

- Data cable (DKU-2)

Audio

- Music stand (MD-1)
- Boom headset (HDB-4)
- Earbud headset (HS-5)

Accessibility

- Loopset (LPS-4)
- Phone adapter (HDA-10)

Car

- Plug-In Car Handsfree (HF-3)
- Headrest handsfree (BHF-3)

Body

- Image album (PD-1)
- Kaleidoscope (RX-11)

16 Reference Information

• Battery information

Charging and discharging

Your device is powered by a rechargeable battery. The full performance of a new battery is achieved only after two or three complete charge and discharge cycles. The battery can be charged and discharged hundreds of times but it will eventually wear out. When the talk and standby times are noticeably shorter than normal, buy a new battery. Use only Nokia approved batteries, and recharge your battery only with Nokia approved chargers designated for this device.

Unplug the charger from the electrical plug and the device when not in use. Do not leave the battery connected to a charger. Overcharging may shorten its lifetime. If left unused, a fully charged battery will lose its charge over time. Temperature extremes can affect the ability of your battery to charge.

Use the battery only for its intended purpose. Never use any charger or battery that is damaged.

Do not short-circuit the battery. Accidental short-circuiting can occur when a metallic object such as a coin, clip, or pen causes direct connection of the positive (+) and negative (-) terminals of the battery. (These look like metal strips on the battery.) This might happen, for example, when you carry a spare battery in your pocket or purse. Short-circuiting the terminals may damage the battery or the connecting object.

Leaving the battery in hot or cold places, such as in a closed car in summer or winter conditions, will reduce the capacity and lifetime of the battery. Always try to keep the battery between 59°F and 77°F (15°C and 25°C). A device with a hot or cold battery may not work temporarily, even when the battery is fully charged. Battery performance is particularly limited in temperatures well below freezing.

Do not dispose of batteries in a fire! Dispose of batteries according to local regulations. Please recycle when possible. Do not dispose as household waste.

• Enhancements

A few practical rules about accessories and enhancements:

- Keep all accessories and enhancements out of the reach of small children.
- When you disconnect the power cord of any accessory or enhancement, grasp and pull the plug, not the cord.
- Check regularly that enhancements installed in a vehicle are mounted and are operating properly.
- Installation of any complex car enhancements must be made by qualified personnel only.

• Enhancements, batteries, and chargers

Check the model number of any charger before use with this device. This device is intended for use when supplied with power from AC-1, ACP-12, ACP-7, or LCH-12 chargers.



Warning: Use only batteries, chargers, and enhancements approved by Nokia for use with this particular model. The use of any other types may invalidate any approval or warranty, and may be dangerous.

For availability of approved enhancements, please check with your dealer. When you disconnect the power cord of any enhancement, grasp and pull the plug, not the cord.

Your device and its enhancements may contain small parts. Keep them out of reach of small children.

• Care and maintenance

Your device is a product of superior design and craftsmanship and should be treated with care. The suggestions below will help you protect your warranty coverage and enjoy your device for many years.

- Keep the device dry. Precipitation, humidity, and all types of liquids or moisture can contain minerals that will corrode electronic circuits. If your device does get wet, remove the battery and allow the device to dry completely before replacing it.
- Do not use or store the device in dusty, dirty areas. Its moving parts and electronic components can be damaged.
- Do not store the device in hot areas. High temperatures can shorten the life of electronic devices, damage batteries, and warp or melt certain plastics.
- Do not store the device in cold areas. When the device returns to its normal temperature, moisture can form inside the device and damage electronic circuit boards.
- Do not attempt to open the device other than as instructed in this guide.
- Do not drop, knock, or shake the device. Rough handling can break internal circuit boards and fine mechanics.
- Do not use harsh chemicals, cleaning solvents, or strong detergents to clean the device.
- Do not paint the device. Paint can clog the moving parts and prevent proper operation.
- Use a soft, clean, dry cloth to clean any lenses (such as camera, proximity sensor, and light sensor lenses).
- Use only the supplied or an approved replacement antenna. Unauthorized antennas, modifications, or attachments could damage the device and may violate regulations governing radio devices.

All of the above suggestions apply equally to your device, battery, charger, or any enhancement. If any device is not working properly, take it to the nearest authorized service facility for service.

• Additional safety information

Operating environment

Remember to follow any special regulations in force in any area and always switch off your device when its use is prohibited or when it may cause interference or danger. Use the device only in its normal operating positions. This device meets RF exposure guidelines when used either in the normal use position against the ear or when positioned at least 5/8 inch (1.5 cm) away from the body. When a carry case, belt clip, or holder is used for body-worn operation, it should not contain metal and should position the device at least 5/8 inch (1.5 cm) away from your body.

In order to transmit data files or messages, this device requires a quality connection to the network. In some cases, transmission of data files or messages may be delayed until such a connection is available. Ensure the above separation distance instructions are followed until the transmission is completed.

Medical devices

Operation of any radio transmitting equipment, including wireless phones, may interfere with the functionality of inadequately protected medical devices. Consult a physician or the manufacturer of the medical device to determine if they are adequately shielded from external RF energy or if you have any questions. Switch off your phone in health care facilities when any regulations posted in these areas instruct you to do so. Hospitals or health care facilities may be using equipment that could be sensitive to external RF energy.

PACEMAKERS

Pacemaker manufacturers recommend that a minimum separation of 6 in (15.3 cm) be maintained between a wireless phone and a pacemaker to avoid potential interference with the pacemaker. These recommendations are consistent with the independent research by and recommendations of Wireless Technology Research. To minimize the potential for interference, persons with pacemakers should

- Always keep the device more than 6 in (15.3 cm) from their pacemaker when the device is switched on
- Not carry the device in a breast pocket
- Hold the device to the ear opposite the pacemaker

If you have any reason to suspect that interference is taking place, switch off your device immediately.

HEARING AID

Some digital wireless devices may interfere with some hearing aids. If interference occurs, consult your service provider.

Vehicles

RF signals may affect improperly installed or inadequately shielded electronic systems in motor vehicles such as electronic fuel injection systems, electronic antiskid (antilock) braking systems, electronic speed control systems, air bag systems. For more information, check with the manufacturer or its representative of your vehicle or any equipment that has been added.

Only qualified personnel should service the device, or install the device in a vehicle. Faulty installation or service may be dangerous and may invalidate any warranty that may apply to the device. Check regularly that all wireless device equipment in your vehicle is mounted and operating properly. Do not store or carry flammable liquids, gases, or explosive materials in the same compartment as the device, its parts, or enhancements. For vehicles equipped with an air bag, remember that an air bags inflate with great force. Do not place objects, including installed or portable wireless equipment in the area over the air bag or in the air bag deployment area. If in-vehicle wireless equipment is improperly installed and the air bag inflates, serious injury could result.

Potentially explosive environments

Switch off your device when in any area with a potentially explosive atmosphere and obey all signs and instructions. Potentially explosive atmospheres include areas where you would normally be advised to turn off your vehicle engine. Sparks in such areas could cause an explosion or fire resulting in bodily injury or even death. Switch off the device at refuelling points such as near gas pumps at service stations. Observe restrictions on the use of radio equipment in fuel depots, storage, and distribution areas, chemical plants or where blasting operations are in progress. Areas with a potentially explosive atmosphere are often but not always clearly marked. They include below deck on boats, chemical transfer or storage facilities, vehicles using liquefied petroleum gas (such as propane or butane), and areas where the air contains chemicals or particles such as grain, dust or metal powders.

FCC regulations prohibit using your wireless device while in the air. The use of wireless telephones in an aircraft may be dangerous to the operation of the aircraft, disrupt the wireless telephone network, and may be illegal.

Failure to observe these instructions may lead to suspension or denial of telephone services to the offender, legal action, or both.

EMERGENCY CALLS

 **Important:** Wireless phones, including this phone, operate using radio signals, wireless networks, landline networks, and user-programmed functions. Because of this, connections in all conditions cannot be guaranteed. You should never rely solely on any wireless phone for essential communications like medical emergencies.

To make an emergency call:

- 1 If the phone is not on, switch it on. Check for adequate signal strength. Some networks may require that a valid SIM card is properly inserted in the phone.
- 2 Press **End** as many times as needed to clear the display and ready the phone for calls.
- 3 Key in the official emergency number for your present location. Emergency numbers vary by location.
- 4 Press **Call**.

If certain features are in use, you may first need to turn those features off before you can make an emergency call. Consult this guide or your service provider. When making an emergency call, give all the necessary information as accurately as possible. Your wireless phone may be the only means of communication at the scene of an accident. Do not end the call until given permission to do so.

• Certification information (SAR)

THE NOKIA 6170 DEVICE MEETS GUIDELINES FOR EXPOSURE TO RADIO WAVES.

Your mobile device is a radio transmitter and receiver. It is designed and manufactured not to exceed the limits for exposure to radio frequency (RF) energy recommended by international guidelines (ICNIRP). These limits establish permitted levels of RF energy for the general population. The guidelines are based on standards that were developed by independent scientific organizations through periodic and thorough evaluation of scientific studies. The standards and guidelines include a substantial safety margin designed to assure the safety of the public, regardless of age and health and to account for any variations in measurements.

The exposure guidelines for mobile devices employ a unit of measurement known as the Specific Absorption Rate or SAR. The SAR limit stated in the international guidelines is 2.0 watts/kilogram (W/kg) averaged over ten grams of tissue. Tests for SAR are conducted using standard operating positions with the device transmitting at its highest certified power level in all tested frequency bands. The actual SAR level of an operating device can be well below the maximum value because the device is designed to use only the power required to reach the network. That amount changes depending on a number of factors such as how close you are to a network base station. The highest SAR value when tested according to international testing procedures for use at the ear for device type RM-47 is 0.22 W/kg and for device type RM-48 is 0.00 W/kg. Your phone's device type is listed on the label located under the battery.

SAR values may vary depending on national reporting and testing requirements and the network band. Use of device accessories and enhancements may result in different SAR values. Additional SAR information may be provided under product information at www.nokia.com.

USA and Canada: The SAR limit of USA (FCC) and Canada (IC) is 1.6 W/kg averaged over one gram of tissue. Device types RM-47 and RM-48 have also been tested against this SAR limit. The highest SAR value reported under this standard during product certification for device type RM-47 when used at the ear is 0.43 W/kg and when properly worn on the body is 0.11 W/kg. The highest SAR value reported under this standard during product certification for device type RM-48 when used at the ear is 0.00 W/kg and when properly worn on the body is 0.00 W/kg. Information about this device can be found on the FCC's website at <http://www.fcc.gov/oet/fccid> by searching the equipment authorization system using FCC IDs: LJPRM-47 and LJPRM-48.

• Technical information

Feature	Specification
Weight	With 760-mAh BL-4C battery: 4.27 oz (121 g) 900/1800/1900 version 4.34 oz (123 g) 850/1800/1900 version
Size	Volume: 4.8 in ³ (79 cm ³) 900/1800/1900 version 5.2 in ³ (85 cm ³) 850/1800/1900 version Length: 3.5 in (88 mm) Width: 1.81 in (46 mm) Thickness: (with fold closed) 0.87 in (22 mm) 0.94 in (24 mm)
Frequency range	GSM 850 824–849 MHz (TX) 869–894 MHz (TX) GSM 900 880.2–914.8 MHz (TX) 925.2–959.8 MHz (RX) GSM 1800 1710.2–1784.8 MHz (TX) 1805.2–1879.8 MHz (RX) GSM 1900 1850.2–1909.8 MHz (TX) 1930.2–1989.8 MHz (RX)
Transmitter output power	Up to 2 W
Battery voltage	3.7 V nominal
Operating temperature	14°F to + 131°F (-10°C to + 55°C)
^aTalk time, Standby time	Talk time: up to 4 hours Standby time: up to 270 hours (11 days)
<p>a. Battery talk and standby times are estimates only and depend on signal strength, network conditions, features used, battery age and condition (including the effect of charging habits), temperatures to which battery is exposed, use in digital mode, and many other factors. Please note that the amount of time a phone is used for calls will affect its standby time. Likewise, the amount of time that the phone is turned on and in the start screen will affect its talk time.</p>	

• Nokia ONE-YEAR LIMITED WARRANTY

Nokia Inc. ("Nokia") warrants that this cellular phone ("Product") is free from defects in material and workmanship that result in Product failure during normal usage, according to the following terms and conditions:

- 1 The limited warranty for the Product extends for ONE (1) year beginning on the date of the purchase of the Product. This one year period is extended by each whole day that the Product is out of your possession for repair under this warranty.
- 2 The limited warranty extends only to the original purchaser ("Consumer") of the Product and is not assignable or transferable to any subsequent purchaser/end-user.
- 3 The limited warranty extends only to Consumers who purchase the Product in the United States of America.
- 4 During the limited warranty period, Nokia will repair, or replace, at Nokia's sole option, any defective parts, or any parts that will not properly operate for their intended use with new or refurbished replacement items if such repair or replacement is needed because of product malfunction or failure during normal usage. No charge will be made to the Consumer for any such parts. Nokia will also pay for the labor charges incurred by Nokia in repairing or replacing the defective parts. The limited warranty does not cover defects in appearance, cosmetic, decorative or structural items, including framing, and any non-operative parts. Nokia's limit of liability under the limited warranty shall be the actual cash value of the Product at the time the Consumer returns the Product for repair, determined by the price paid by the Consumer for the Product less a reasonable amount for usage. Nokia shall not be liable for any other losses or damages. These remedies are the Consumer's exclusive remedies for breach of warranty.
- 5 Upon request from Nokia, the Consumer must prove the date of the original purchase of the Product by a dated bill of sale or dated itemized receipt.
- 6 The Consumer shall bear the cost of shipping the Product to Nokia in Melbourne, Florida. Nokia shall bear the cost of shipping the Product back to the Consumer after the completion of service under this limited warranty.
- 7 The Consumer shall have no coverage or benefits under this limited warranty if any of the following conditions are applicable:
 - a) The Product has been subjected to abnormal use, abnormal conditions, improper storage, exposure to moisture or dampness, unauthorized modifications, unauthorized connections, unauthorized repair, misuse, neglect, abuse, accident, alteration, improper installation, or other acts which are not the fault of Nokia, including damage caused by shipping.

- b) The Product has been damaged from external causes such as collision with an object, or from fire, flooding, sand, dirt, windstorm, lightning, earthquake or damage from exposure to weather conditions, an Act of God, or battery leakage, theft, blown fuse, or improper use of any electrical source, damage caused by computer or internet viruses, bugs, worms, Trojan Horses, cancelbots or damage caused by the connection to other products not recommended for interconnection by Nokia.
 - c) Nokia was not advised in writing by the Consumer of the alleged defect or malfunction of the Product within fourteen (14) days after the expiration of the applicable limited warranty period.
 - d) The Product serial number plate or the enhancement data code has been removed, defaced or altered.
 - e) The defect or damage was caused by the defective function of the cellular system or by inadequate signal reception by the external antenna, or viruses or other software problems introduced into the Product.
- 8** Nokia does not warrant uninterrupted or error-free operation of the Product. If a problem develops during the limited warranty period, the Consumer shall take the following step-by-step procedure:
- a) The Consumer shall return the Product to the place of purchase for repair or replacement processing.
 - b) If "a" is not convenient because of distance (more than 50 miles) or for other good cause, the Consumer shall ship the Product prepaid and insured to:
Nokia Inc., Attn: Repair Department
795 West Nasa Blvd.
Melbourne, FL 32901
 - c) The Consumer shall include a return address, daytime phone number and/or fax number, complete description of the problem, proof of purchase and service agreement (if applicable). Expenses related to removing the Product from an installation are not covered under this limited warranty.
 - d) The Consumer will be billed for any parts or labor charges not covered by this limited warranty. The Consumer will be responsible for any expenses related to reinstallation of the Product.
 - e) Nokia will repair the Product under the limited warranty within 30 days after receipt of the Product. If Nokia cannot perform repairs covered under this limited warranty within 30 days, or after a reasonable number of attempts to repair the same defect, Nokia at its option, will provide a replacement Product or refund the purchase price of the Product less a reasonable amount for usage. In some states the Consumer may have the right to a loaner if the repair of the Product takes more than ten (10) days. Please contact the Customer Service Center at Nokia at the telephone number listed at the end of this warranty if you need a loaner and the repair of the Product has taken or is estimated to take more than ten (10) days.

Reference Information

- f) If the Product is returned during the limited warranty period, but the problem with the Product is not covered under the terms and conditions of this limited warranty, the Consumer will be notified and given an estimate of the charges the Consumer must pay to have the Product repaired, with all shipping charges billed to the Consumer. If the estimate is refused, the Product will be returned freight collect. If the Product is returned after the expiration of the limited warranty period, Nokia's normal service policies shall apply and the Consumer will be responsible for all shipping charges.
- 9 You (the Consumer) understand that the product may consist of refurbished equipment that contains used components, some of which have been reprocessed. The used components comply with Product performance and reliability specifications.
- 10 ANY IMPLIED WARRANTY OF MERCHANTABILITY, OR FITNESS FOR A PARTICULAR PURPOSE OR USE, SHALL BE LIMITED TO THE DURATION OF THE FOREGOING LIMITED WRITTEN WARRANTY. OTHERWISE, THE FOREGOING LIMITED WARRANTY IS THE CONSUMER'S SOLE AND EXCLUSIVE REMEDY AND IS IN LIEU OF ALL OTHER WARRANTIES, EXPRESS OR IMPLIED. NOKIA SHALL NOT BE LIABLE FOR SPECIAL, INCIDENTAL, PUNITIVE OR CONSEQUENTIAL DAMAGES, INCLUDING BUT NOT LIMITED TO LOSS OF ANTICIPATED BENEFITS OR PROFITS, LOSS OF SAVINGS OR REVENUE, LOSS OF DATA, PUNITIVE DAMAGES, LOSS OF USE OF THE PRODUCT OR ANY ASSOCIATED EQUIPMENT, COST OF CAPITAL, COST OF ANY SUBSTITUTE EQUIPMENT OR FACILITIES, DOWNTIME, THE CLAIMS OF ANY THIRD PARTIES, INCLUDING CUSTOMERS, AND INJURY TO PROPERTY, RESULTING FROM THE PURCHASE OR USE OF THE PRODUCT OR ARISING FROM BREACH OF THE WARRANTY, BREACH OF CONTRACT, NEGLIGENCE, STRICT TORT, OR ANY OTHER LEGAL OR EQUITABLE THEORY, EVEN IF NOKIA KNEW OF THE LIKELIHOOD OF SUCH DAMAGES. NOKIA SHALL NOT BE LIABLE FOR DELAY IN RENDERING SERVICE UNDER THE LIMITED WARRANTY, OR LOSS OF USE DURING THE PERIOD THAT THE PRODUCT IS BEING REPAIRED.
- 11 Some states do not allow limitation of how long an implied warranty lasts, so the one year warranty limitation may not apply to you (the Consumer). Some states do not allow the exclusion or limitation of incidental and consequential damages, so certain of the above limitations or exclusions may not apply to you (the Consumer). This limited warranty gives the Consumer specific legal rights and the Consumer may also have other rights which vary from state to state.
- 12 Nokia neither assumes nor authorizes any authorized service center or any other person or entity to assume for it any other obligation or liability beyond that which is expressly provided for in this limited warranty including the provider or seller of any extended warranty or service agreement.

- 13 This is the entire warranty between Nokia and the Consumer, and supersedes all prior and contemporaneous agreements or understandings, oral or written, relating to the Product, and no representation, promise or condition not contained herein shall modify these terms.
- 14 This limited warranty allocates the risk of failure of the Product between the Consumer and Nokia. The allocation is recognized by the Consumer and is reflected in the purchase price.
- 15 Any action or lawsuit for breach of warranty must be commenced within eighteen (18) months following purchase of the Product.
- 16 Questions concerning this limited warranty may be directed to:
Nokia Inc.
Attn: Customer Service
7725 Woodland Center Blvd., Ste. 150
Tampa, FL 33614
Telephone: 1-888-NOKIA-2U (1-888-665-4228)
Facsimile: (813) 249-9619
TTY/TDD Users Only: 1-800-24-NOKIA (1-800-246-6542)
- 17 The limited warranty period for Nokia supplied attachments and accessories is specifically defined within their own warranty cards and packaging.



Appendix A Message from the CTIA

Appendix A Message from the CTIA (Cellular Telecommunications & Internet Association) to all users of mobile phones

© 2001 Cellular Telecommunications & Internet Association. All Rights Reserved. 1250 Connecticut Avenue, NW Suite 800, Washington, DC 20036.
Phone: (202) 785-0081

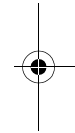
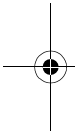

FCC DRAFT

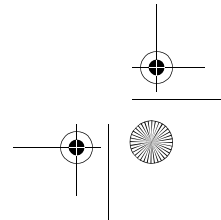
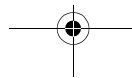
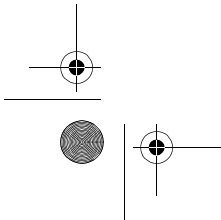

Safety is the most important call you will ever make.

A Guide to Safe and Responsible Wireless Phone Use

Tens of millions of people in the U.S. today take advantage of the unique combination of convenience, safety and value delivered by the wireless telephone. Quite simply, the wireless phone gives people the powerful ability to communicate by voice--almost anywhere, anytime--with the boss, with a client, with the kids, with emergency personnel or even with the police. Each year, Americans make billions of calls from their wireless phones, and the numbers are rapidly growing.

But an important responsibility accompanies those benefits, one that every wireless phone user must uphold. When driving a car, driving is your first responsibility. A wireless phone can be an invaluable tool, but good judgment must be exercised at all times while driving a motor vehicle--whether on the phone or not.

The basic lessons are ones we all learned as teenagers. Driving requires alertness, caution and courtesy. It requires a heavy dose of basic common sense--keep your head up, keep your eyes on the road, check your mirrors frequently and watch out for other drivers. It requires obeying all traffic signs and signals and staying within the speed limit. It means using seatbelts and requiring other passengers to do the same.

But with wireless phone use, driving safely means a little more. This brochure is a call to wireless phone users everywhere to make safety their first priority when behind the wheel of a car. Wireless telecommunications is keeping us in touch, simplifying our lives, protecting us in emergencies and providing opportunities to help others in need.

When it comes to the use of wireless phones, *safety is your most important call.*

Wireless Phone "Safety Tips"

Below are safety tips to follow while driving and using a wireless phone which should be easy to remember.

- 1 Get to know your wireless phone and its features such as speed dial and redial. Carefully read your instruction manual and learn to take advantage of valuable features most phones offer, including automatic redial and memory. Also, work to memorize the phone keypad so you can use the speed dial function without taking your attention off the road.
- 2 When available, use a hands free device. A number of hands free wireless phone accessories are readily available today. Whether you choose an installed mounted device for your wireless phone or a speaker phone accessory, take advantage of these devices if available to you.
- 3 Position your wireless phone within easy reach. Make sure you place your wireless phone within easy reach and where you can grab it without removing your eyes from the road. If you get an incoming call at an inconvenient time, if possible, let your voice mail answer it for you.

Appendix A Message from the CTIA

- 4 Suspend conversations during hazardous driving conditions or situations. Let the person you are speaking with know you are driving; if necessary, suspend the call in heavy traffic or hazardous weather conditions. Rain, sleet, snow and ice can be hazardous, but so is heavy traffic. As a driver, your first responsibility is to pay attention to the road.
- 5 Do not take notes or look up phone numbers while driving. If you are reading an address book or business card, or writing a "to do" list while driving a car, you are not watching where you are going. It's common sense. Don't get caught in a dangerous situation because you are reading or writing and not paying attention to the road or nearby vehicles.
- 6 Dial sensibly and assess the traffic; if possible, place calls when you are not moving or before pulling into traffic. Try to plan your calls before you begin your trip or attempt to coincide your calls with times you may be stopped at a stop sign, red light or otherwise stationary. But if you need to dial while driving, follow this simple tip--dial only a few numbers, check the road and your mirrors, then continue.
- 7 Do not engage in stressful or emotional conversations that may be distracting. Stressful or emotional conversations and driving do not mix--they are distracting and even dangerous when you are behind the wheel of a car. Make people you are talking with aware you are driving and if necessary, suspend conversations which have the potential to divert your attention from the road.
- 8 Use your wireless phone to call for help. Your wireless phone is one of the greatest tools you can own to protect yourself and your family in dangerous situations--with your phone at your side, help is only three numbers away. Dial 9-1-1 or other local emergency number in the case of fire, traffic accident, road hazard or medical emergency. Remember, it is a free call on your wireless phone!
- 9 Use your wireless phone to help others in emergencies. Your wireless phone provides you a perfect opportunity to be a "Good Samaritan" in your community. If you see an auto accident, crime in progress or other serious emergency where lives are in danger, call 9-1-1 or other local emergency number, as you would want others to do for you.
- 10 Call roadside assistance or a special wireless non-emergency assistance number when necessary. Certain situations you encounter while driving may require attention, but are not urgent enough to merit a call for emergency services. But you still can use your wireless phone to lend a hand. If you see a broken-down vehicle posing no serious hazard, a broken traffic signal, a minor traffic accident where no one appears injured or a vehicle you know to be stolen, call roadside assistance or other special non-emergency wireless number.



Careless, distracted individuals and people driving irresponsibly represent a hazard to everyone on the road. Since 1984, the Cellular Telecommunications Industry Association and the wireless industry have conducted educational outreach to inform wireless phone users of their responsibilities as safe drivers and good citizens. As we approach a new century, more and more of us will take advantage of the benefits of wireless telephones. And, as we take to the roads, we all have a responsibility to drive safely.

The wireless industry reminds you to use your phone safely when driving.

For more information, please call 1-888-901-SAFE.

For updates: <http://www.wow-com.com/consumer/issues/driving/articles.cfm?ID=85>

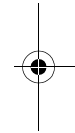
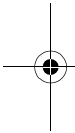

FCC DRAFT



Appendix B Message from the FDA

Appendix B Message from the FDA

(U.S. Food and Drug Administration) to all users of mobile phones

©July 18, 2001 For updates: <http://www.fda.gov/cdrh/phones>

FCC DRAFT

Consumer Update on Wireless Phones

U.S. Food and Drug Administration

1. Do wireless phones pose a health hazard?

The available scientific evidence does not show that any health problems are associated with using wireless phones. There is no proof, however, that wireless phones are absolutely safe. Wireless phones emit low levels of radiofrequency energy (RF) in the microwave range while being used. They also emit very low levels of RF when in the stand-by mode. Whereas high levels of RF can produce health effects (by heating tissue), exposure to low level RF that does not produce heating effects causes no known adverse health effects. Many studies of low level RF exposures have not found any biological effects. Some studies have suggested that some biological effects may occur, but such findings have not been confirmed by additional research. In some cases, other researchers have had difficulty in reproducing those studies, or in determining the reasons for inconsistent results.

2. What is FDA's role concerning the safety of wireless phones?

Under the law, FDA does not review the safety of radiation-emitting consumer products such as wireless phones before they can be sold, as it does with new drugs or medical devices. However, the agency has authority to take action if wireless phones are shown to emit radiofrequency energy (RF) at a level that is hazardous to the user. In such a case, FDA could require the manufacturers of wireless phones to notify users of the health hazard and to repair, replace or recall the phones so that the hazard no longer exists.

Although the existing scientific data do not justify FDA regulatory actions, FDA has urged the wireless phone industry to take a number of steps, including the following:

- Support needed research into possible biological effects of RF of the type emitted by wireless phones;
- Design wireless phones in a way that minimizes any RF exposure to the user that is not necessary for device function; and
- Cooperate in providing users of wireless phones with the best possible information on possible effects of wireless phone use on human health.

FDA belongs to an interagency working group of the federal agencies that have responsibility for different aspects of RF safety to ensure coordinated efforts at the federal level. The following agencies belong to this working group:

- National Institute for Occupational Safety and Health
- Environmental Protection Agency
- Federal Communications Commission
- Occupational Safety and Health Administration
- National Telecommunications and Information Administration

Appendix B Message from the FDA

The National Institutes of Health participates in some interagency working group activities, as well.

FDA shares regulatory responsibilities for wireless phones with the Federal Communications Commission (FCC). All phones that are sold in the United States must comply with FCC safety guidelines that limit RF exposure. FCC relies on FDA and other health agencies for safety questions about wireless phones. FCC also regulates the base stations that the wireless phone networks rely upon. While these base stations operate at higher power than do the wireless phones themselves, the RF exposures that people get from these base stations are typically thousands of times lower than those they can get from wireless phones. Base stations are thus not the subject of the safety questions discussed in this document.

3. What kinds of phones are the subject of this update?

The term wireless phone refers here to hand-held wireless phones with built-in antennas, often called cell mobile or PCS phones. These types of wireless phones can expose the user to measurable radiofrequency energy (RF) because of the short distance between the phone and the user's head. These RF exposures are limited by Federal Communications Commission safety guidelines that were developed with the advice of FDA and other federal health and safety agencies. When the phone is located at greater distances from the user, the exposure to RF is drastically lower because a person's RF exposure decreases rapidly with increasing distance from the source. The so-called cordless phones, which have a base unit connected to the telephone wiring in a house, typically operate at far lower power levels, and thus produce RF exposures far below the FCC safety limits.

4. What are the results of the research done already?

The research done thus far has produced conflicting results, and many studies have suffered from flaws in their research methods. Animal experiments investigating the effects of radiofrequency energy (RF) exposures characteristic of wireless phones have yielded conflicting results that often cannot be repeated in other laboratories. A few animal studies, however, have suggested that low levels of RF could accelerate the development of cancer in laboratory animals. However, many of the studies that showed increased tumor development used animals that had been genetically engineered or treated with cancer-causing chemicals so as to be pre-disposed to develop cancer in the absence of RF exposure. Other studies exposed the animals to RF for up to 22 hours per day. These conditions are not similar to the conditions under which people use wireless phones, so we don't know with certainty what the results of such studies mean for human health.

Three large epidemiology studies have been published since December 2000. Between them, the studies investigated any possible association between the use of wireless phones and primary brain cancer, glioma, meningioma, or acoustic neuroma, tumors of the brain or salivary gland, leukemia, or other

cancers. None of the studies demonstrated the existence of any harmful health effects from wireless phone RF exposures. However, none of the studies can answer questions about long-term exposures, since the average period of phone use in these studies was around three years.

5. What research is needed to decide whether RF exposure from wireless phones poses a health risk?

A combination of laboratory studies and epidemiological studies of people actually using wireless phones would provide some of the data that are needed. Lifetime animal exposure studies could be completed in a few years. However, very large numbers of animals would be needed to provide reliable proof of a cancer promoting effect if one exists. Epidemiological studies can provide data that is directly applicable to human populations, but 10 or more years follow-up may be needed to provide answers about some health effects, such as cancer. This is because the interval between the time of exposure to a cancer-causing agent and the time tumors develop - if they do - may be many, many years. The interpretation of epidemiological studies is hampered by difficulties in measuring actual RF exposure during day-to-day use of wireless phones. Many factors affect this measurement, such as the angle at which the phone is held, or which model of phone is used.

6. What is FDA doing to find out more about the possible health effects of wireless phone RF?

FDA is working with the U.S. National Toxicology Program and with groups of investigators around the world to ensure that high priority animal studies are conducted to address important questions about the effects of exposure to radiofrequency energy (RF).

FDA has been a leading participant in the World Health Organization International Electromagnetic Fields (EMF) Project since its inception in 1996. An influential result of this work has been the development of a detailed agenda of research needs that has driven the establishment of new research programs around the world. The Project has also helped develop a series of public information documents on EMF issues.

FDA and the Cellular Telecommunications & Internet Association (CTIA) have a formal Cooperative Research and Development Agreement (CRADA) to do research on wireless phone safety. FDA provides the scientific oversight, obtaining input from experts in government, industry, and academic organizations. CTIA-funded research is conducted through contracts to independent investigators. The initial research will include both laboratory studies and studies of wireless phone users. The CRADA will also include a broad assessment of additional research needs in the context of the latest research developments around the world.

7. How can I find out how much radiofrequency energy exposure I can get by using my wireless phone?

All phones sold in the United States must comply with Federal Communications Commission (FCC) guidelines that limit radiofrequency energy (RF) exposures. FCC established these guidelines in consultation with FDA and the other federal health and safety agencies. The FCC limit for RF exposure from wireless telephones is set at a Specific Absorption Rate (SAR) of 1.6 watts per kilogram (1.6 W/kg). The FCC limit is consistent with the safety standards developed by the Institute of Electrical and Electronic Engineering (IEEE) and the National Council on Radiation Protection and Measurement. The exposure limit takes into consideration the body's ability to remove heat from the tissues that absorb energy from the wireless phone and is set well below levels known to have effects.

Manufacturers of wireless phones must report the RF exposure level for each model of phone to the FCC. The FCC website (<http://www.fcc.gov/oet/rfsafety>) gives directions for locating the FCC identification number on your phone so you can find your phone's RF exposure level in the online listing.

8. What has FDA done to measure the radiofrequency energy coming from wireless phones?

The Institute of Electrical and Electronic Engineers (IEEE) is developing a technical standard for measuring the radiofrequency energy (RF) exposure from wireless phones and other wireless handsets with the participation and leadership of FDA scientists and engineers. The standard, Recommended Practice for Determining the Spatial-Peak Specific Absorption Rate (SAR) in the Human Body Due to Wireless Communications Devices: Experimental Techniques, sets forth the first consistent test methodology for measuring the rate at which RF is deposited in the heads of wireless phone users. The test method uses a tissue-simulating model of the human head.

Standardized SAR test methodology is expected to greatly improve the consistency of measurements made at different laboratories on the same phone. SAR is the measurement of the amount of energy absorbed in tissue, either by the whole body or a small part of the body. It is measured in watts/kg (or milliwatts/g) of matter. This measurement is used to determine whether a wireless phone complies with safety guidelines.

9. What steps can I take to reduce my exposure to radiofrequency energy from my wireless phone?

If there is a risk from these products--and at this point we do not know that there is--it is probably very small. But if you are concerned about avoiding even potential risks, you can take a few simple steps to minimize your exposure to radiofrequency energy (RF). Since time is a key factor in how much exposure a person receives, reducing the amount of time spent using a wireless phone will reduce RF exposure.

If you must conduct extended conversations by wireless phone every day, you could place more distance between your body and the source of the RF, since the exposure level drops off dramatically with distance. For example, you could use a headset and carry the wireless phone away from your body or use a wireless phone connected to a remote antenna.

Again, the scientific data do not demonstrate that wireless phones are harmful. But if you are concerned about the RF exposure from these products, you can use measures like those described above to reduce your RF exposure from wireless phone use.

10. What about children using wireless phones?

The scientific evidence does not show a danger to users of wireless phones, including children and teenagers. If you want to take steps to lower exposure to radiofrequency energy (RF), the measures described above would apply to children and teenagers using wireless phones. Reducing the time of wireless phone use and increasing the distance between the user and the RF source will reduce RF exposure. Some groups sponsored by other national governments have advised that children be discouraged from using wireless phones at all. For example, the government in the United Kingdom distributed leaflets containing such a recommendation in December 2000. They noted that no evidence exists that using a wireless phone causes brain tumors or other ill effects. Their recommendation to limit wireless phone use by children was strictly precautionary; it was not based on scientific evidence that any health hazard exists.

11. What about wireless phone interference with medical equipment?

Radiofrequency energy (RF) from wireless phones can interact with some electronic devices. For this reason, FDA helped develop a detailed test method to measure electromagnetic interference (EMI) of implanted cardiac pacemakers and defibrillators from wireless telephones. This test method is now part of a standard sponsored by the Association for the Advancement of Medical Instrumentation (AAMI). The final draft, a joint effort by FDA, medical device manufacturers, and many other groups, was completed in late 2000. This standard will allow manufacturers to ensure that cardiac pacemakers and defibrillators are safe from wireless phone EMI. FDA has tested hearing aids for interference from handheld wireless phones and helped develop a voluntary standard sponsored by the Institute of Electrical and Electronic Engineers (IEEE). This standard specifies test methods and performance requirements for hearing aids and wireless phones so that no interference occurs when a person uses a compatible phone and an accompanied hearing aid at the same time. This standard was approved by the IEEE in 2000. FDA continues to monitor the use of wireless phones for possible interactions with other medical devices. Should harmful interference be found to occur, FDA will conduct testing to assess the interference and work to resolve the problem.

Appendix B Message from the FDA

12. Where can I find additional information?

For additional information, please refer to the following resources:

- FDA web page on wireless phones
<http://www.fda.gov/cdrh/phones/index.html>
- Federal Communications Commission (FCC) RF Safety Program
<http://www.fcc.gov/oet/rfsafety>
- International Commission on Non-Ionizing Radiation Protection
<http://www.icnirp.de>
- World Health Organization (WHO) International EMF Project
<http://www.who.int/emf>
- National Radiological Protection Board (UK)
<http://www.nrpb.org.uk/>

July 18, 2001 For updates: <http://www.fda.gov/cdrh/phones>

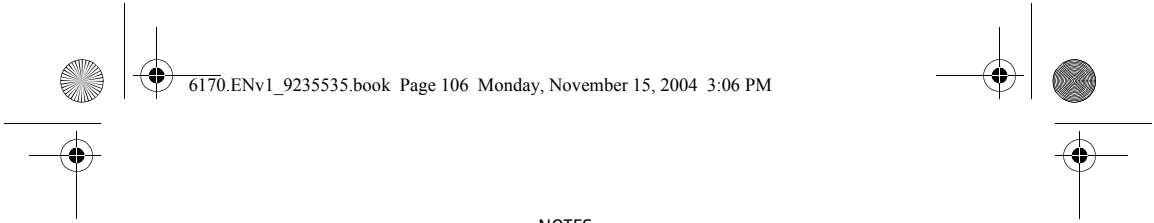

NOTES

FCC DRAFT

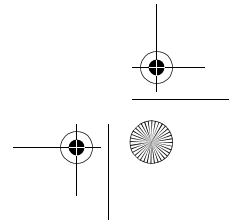
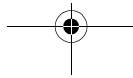
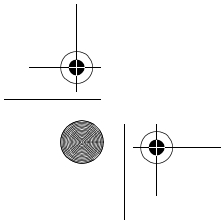
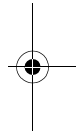
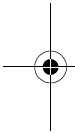

Index

Numerics

1-touch dialing 38, 48

A

accessibility 11
activate call forwarding 47
alarm clock 60
answer a call 18
anykey answer 48
applications menu 72

B

battery 83
bookmarks 77
business cards 37

C

calculator 69
calendar 61
call
 answer 18
 forwarding 47
 log 41
 make 17
 record 59
 reject 18
 restriction 52
 waiting 49
caller
 groups 39
 ID 49
camera 57
clock radio 60
closed user groups 53
connection ports 83

connectivity

infrared 45

contacts

1-touch dialing 38
add image 36
business cards 37
call from 36
caller groups 39
copy 37
delete 36
find entry 36
menu options 34
save 34
search 36

currency conversion 69

customer care 5

customize profile 42

D

data communication 47
date settings 43
definition of terms 90
delete

 1-touch dialing entry 38
 contact entry 36
 fixed dialing entry 53
 messages 25
 voice tags 39

dialed numbers, view 41

dialing

1-touch 38
fixed 52

dictionary 21

display

language 49
settings 43

download

applications 73
games 72

E

- emergency calls
 - while online 78
 - with keys locked 17
- enhancements 83

F

- fixed dialing 52
- folders
 - gallery 56
 - message 23
- forward messages 25

G

- gallery 56
- games 72
- glossary 90
- GPRS mobile link 45

H

- help text 50

I

IM

- chat 29
- contacts 30
- log in 28
- offline menu 28
- online menu 28
- settings 31

images

- add to contacts 36
- edit in gallery 56

info

- message service 32
- infrared connectivity 45
- install SIM card 13
- instant messaging, see IM

Internet

- options 79
- security 79
- service 75

K

- keyguard 17

L

- language 49
- lap timer 70

M

- make a call 17
- media 57
 - camera 57
 - player 58
 - voice recorder 59
- menus 12
- message alert tone 42
- messages
 - delete 25
 - folders 23
 - forward 25
 - info message service 32
 - instant 27
 - linked 22
 - multimedia 25
 - read 24
 - reply 24
 - send 23, 26
 - service commands 33
 - settings 23, 25
 - text 23
 - voice 32
- missed calls, view 41
- mobile link 45
 - GPRS 45
- multimedia messages 25

N

Nokia PC Suite 11

notes

- calendar 61
- to-do 63

O

organizer 60

- alarm clock 60
- calendar 61
- to-do list 63

over the air settings 11

P

PC Suite 11

personal shortcuts 44

phone

- memory 49

PIN code 51, 54

private groups 29

profiles 42

PUK codes 55

Q

quick guide ii

R

read messages 24

received calls, view 41

record

- calls 59
- video clip 57
- voice tags 39

redial 48

registration 4

reject a call 18

reply to messages 24

restore factory settings 55

ringing tone 42

ringing volume 42

S

safety 1

security

- code 54
- mobile Internet 79

select profile 42

send

- business card 37
- caller ID 49
- multimedia messages 26
- text messages 23

service

- commands 33

set

- alarm clock 60
- time and date 43

settings 42

- call 47
- camera 58
- display 43
- enhancements 50
- IM 31
- OTA 11
- personal shortcuts 44
- phone 49
- restore factory settings 55
- security 51
- time and date 43
- tone 43

shortcuts

- menu 12
- personal 44

SIM card 13

speed dialing 38

stopwatch 70
summary after call 49
synchronization 64

T

text
 entry 20
 messages 23
time settings 43
timed profile 42
timer 71
to-do list 63
tones 42
turn off alarm clock 60

V

vibrating alert 42
video recorder 57

view

 call lists 41
voice
 dialing 38
 messages 32
 recorder 59
voice tags 39
 change 39
volume, ringing tone 42

W

wallet 66
welcome note 50

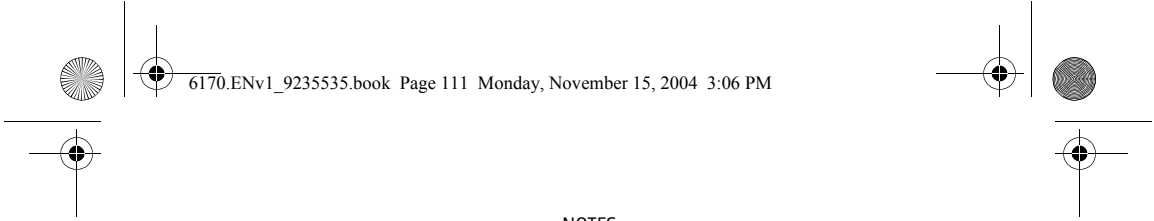

NOTES

FCC DRAFT

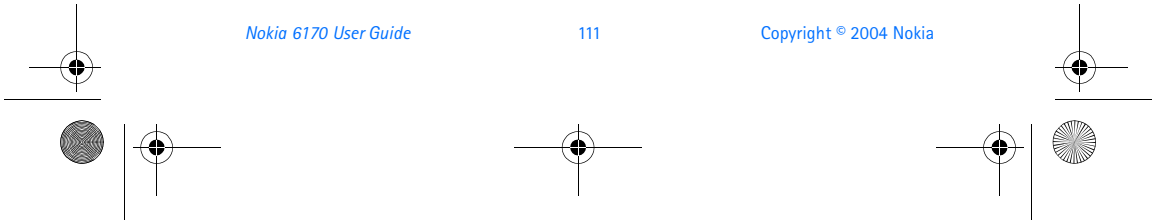

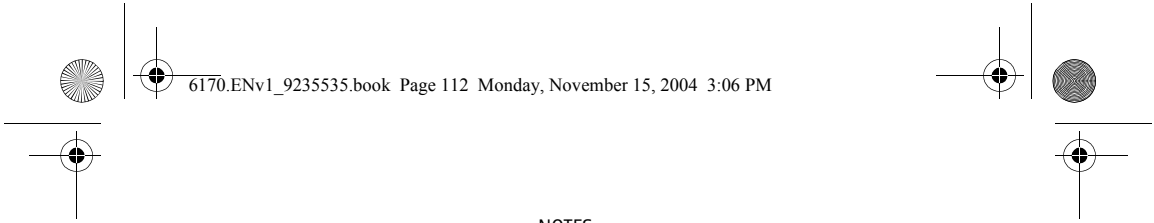

NOTES

FCC DRAFT

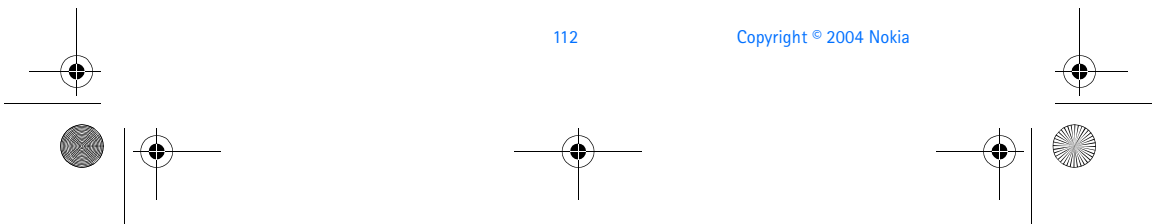

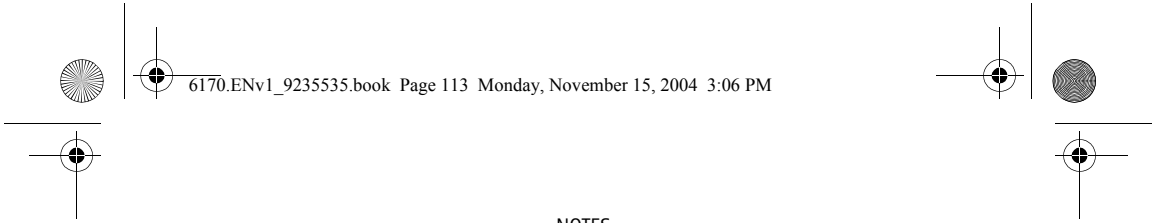

NOTES

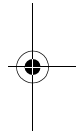
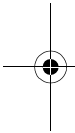

FCC DRAFT

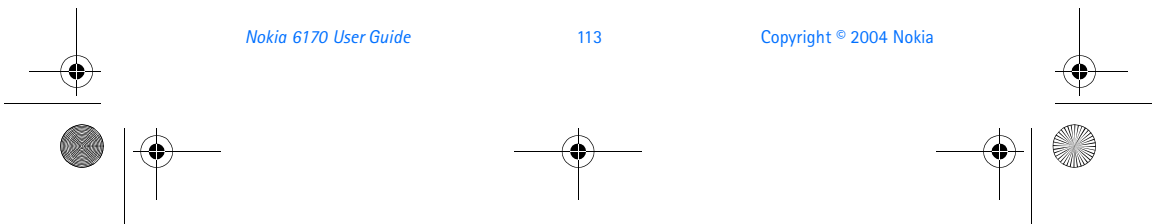



Para obtener un manual del usuario en español favor de llamar o enviar un fax al teléfono 1-888-NOKIA-2U, fax 813-249-9619.

FCC DRAFT

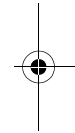
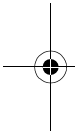

**Nokia 6170 User Guide
9235535**

