

Nokia 3720 classic User Guide



555555
Issue 1





2 Contents

Contents		Listen to music	29
		Web	32
		Games and applications	33
Safety	4	Maps	34
Durability	4	Download maps	34
Get started	6	Maps and GPS	35
Keys and parts	6	Extra services	35
Insert the SIM card and battery	6	Organise	36
Insert and remove the memory card	7	Manage contacts	36
Charge the battery	8	Business cards	37
Antenna	9	Date and time	37
Accessories	9	Alarm clock	37
Switch it on	10	Calendar	38
About your device	10	To-do list	38
Network services	11	Notes	38
Access codes	11	Nokia PC Suite	38
Switch the device on and off	12	Calculator	38
Standby mode	12	Countdown timer	38
Navigate the menus	13	Stopwatch	39
Torch	14	Support and updates	39
Keypad lock	14	Support	39
Functions without a SIM card	14	My Nokia	39
Flight profile	14	Download content	40
Make it your device	15	Software updates using your PC	40
Basic settings	15	Software updates over the air	40
Personalise your phone	16	Restore factory settings	41
Connect	18	Green tips	41
Network provider services	20	Save energy	41
Stay in touch	21	Recycle	41
Make calls	21	Learn more	41
Text and messages	23	Digital rights management	42
E-mail	26	Third-party applications	42
Image and video	27	Accessories	42
Capture an image	27	Battery	42
Record a video clip	27	Battery and charger information	42
Camera and video options	28	Nokia battery authentication	
Gallery	28	guidelines	43
Entertainment	29		





Care and maintenance	43
Recycle	44
Additional safety information	44
Magnets and magnetic fields	44
Small children	44
Operating environment	44
Medical devices	44
Vehicles	44
Potentially explosive environments	45
Emergency calls	45
Certification information (SAR)	45
Index	46



4 Safety

Safety

Read these simple guidelines. Not following them may be dangerous or illegal. Read the complete user guide for further information.

SWITCH ON SAFELY



Do not switch the device on when wireless phone use is prohibited or when it may cause interference or danger.

ROAD SAFETY COMES FIRST



Obey all local laws. Always keep your hands free to operate the vehicle while driving. Your first consideration while driving should be road safety.

INTERFERENCE



All wireless devices may be susceptible to interference, which could affect performance.

SWITCH OFF IN RESTRICTED AREAS



Follow any restrictions. Switch the device off in aircraft, near medical equipment, fuel, chemicals, or blasting areas.

QUALIFIED SERVICE



Only qualified personnel may install or repair this product.

ACCESSORIES AND BATTERIES



Use only approved accessories and batteries. Do not connect incompatible products.

Durability

Your device is made for rough ambient conditions. It is tested and certified according to the international standard IEC 60529/level IP54 regarding water and dust protection and according to IEC 60068-2-27 regarding shock protection.

Accessories to be used with this device do not meet the same durability, dust-resistance, or water-resistance specifications as the device itself. For example, all the chargers are only to be used in dry conditions. They should never be used when damp or wet.

Using your device in wet or dusty conditions

- Water-resistance means resistance against clean freshwater only. Do not expose the device to any other type of liquid. For example, do not expose the device to ocean water, drinks, mud, or liquid chemicals or detergents.
- Do not submerge the device in water.
- Do not expose the device to hot water.
- If the device has been exposed to water, wipe it off with a dry cloth. If it has been exposed to salt water or other liquid, splash immediately some clean freshwater on the device. The device must be carefully wiped dry.
- Never connect anything to the bottom connectors if they are dusty, wet or damp. For example, never charge the device when the bottom connectors are wet or damp. Never try to connect anything to the connectors by using force as this may break the device.
- Before opening the back cover (1), clean and dry the device to prevent water or dust from reaching the interior of the device and only open

the device in dry and clean conditions. Make sure the interior of your device and the back cover (1) seals are dry, clean, and free of any foreign objects. Foreign objects or dust may damage the seals against water.

- If connectors are dusty, they must be carefully cleaned before using them. To clean the bottom connectors and the bottom connector area, you may open the connector cover (2) at the bottom of the device and carefully splash some clean freshwater onto the bottom connectors to remove the dust. Wipe the device and connector area dry carefully. The inside of the connectors must be allowed to dry. Never insert any tools into connectors or connector area.

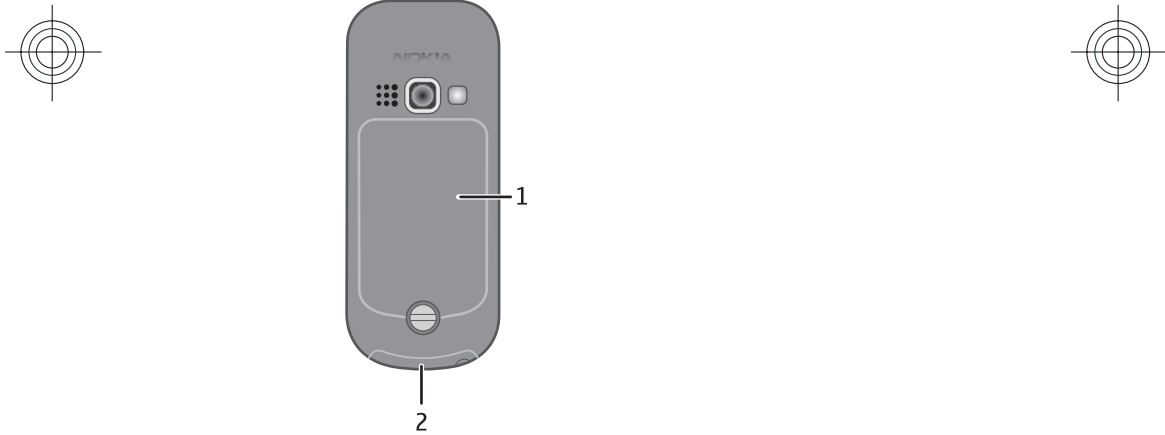

- 1 Back cover
- 2 Connector cover



6 Get started

Get started

Get to know your device, insert the battery, SIM card, and memory card, and learn some important information.

Keys and parts

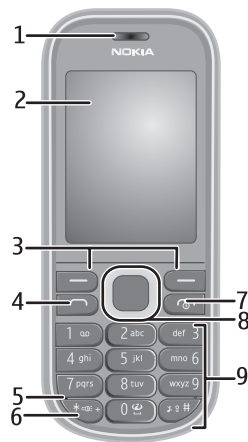

- 1 Earpiece
- 2 Display
- 3 Left and right selection key
- 4 Call key
- 5 Microphone
- 6 Torch key
- 7 End/Power key
- 8 Navi™ key (scroll key)
- 9 Keypad

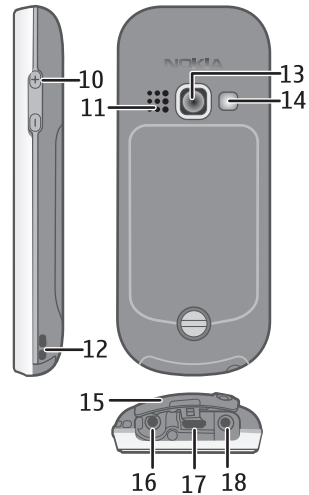

- 10 Volume keys
- 11 Loudspeaker
- 12 Wrist strap eyelet
- 13 Camera lens
- 14 Camera flash
- 15 Connector cover
- 16 Nokia AV Connector (2.5 mm)
- 17 Micro USB cable connector
- 18 Charger connector

Insert the SIM card and battery

This device is intended for use with a BL-5CT battery. Always use original Nokia batteries. See "Nokia battery authentication guidelines", p. 43.

The SIM card and its contacts can be easily damaged by scratches or bending, so be careful when handling, inserting, or removing the card.

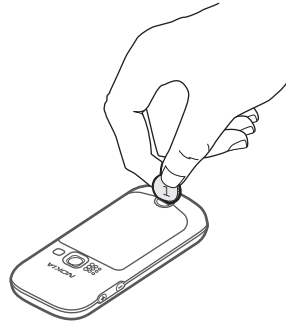

To release and replace the back cover, turn the screw with a coin or screwdriver.

- 1 To release the back cover, turn the screw anticlockwise as far as it goes (1, 2). Do not screw too tightly.

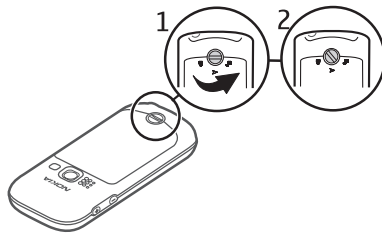

- 2 Remove the back cover and battery (3, 4).

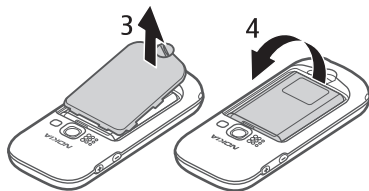

- 3 Open the SIM card holder. Insert the SIM card into the holder with the

contact surface facing down (5). Close the SIM card holder.

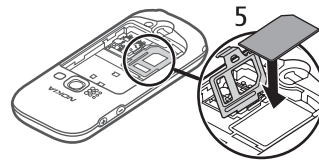

- 4 Line up the battery contacts, and insert the battery (6). Replace the back cover (7). The back cover fits tightly. Press the back cover down until it locks into place.

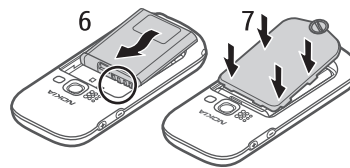

- 5 Ensure that the back cover is properly in place. Lock the back cover by turning the screw clockwise as far as it goes (8, 9). Do not screw too tightly.

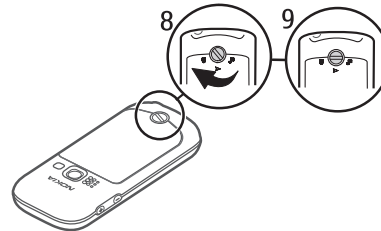

Insert and remove the memory card



8 Get started

Use only compatible microSD cards approved by Nokia for use with this device. Nokia uses approved industry standards for memory cards, but some brands may not be fully compatible with this device. Incompatible cards may damage the card and the device and corrupt data stored on the card.

Your device supports microSD cards with a capacity of up to 8 GB.

The size of a single file must not exceed 2 GB.

Insert the memory card

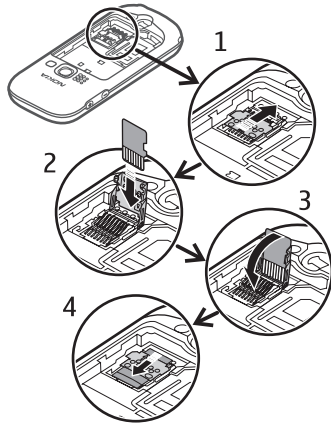

- 1 Remove the back cover and the battery.
- 2 Open the memory card holder (1).
- 3 Insert the card into the memory card holder with the contact surface facing down (2).
- 4 Close the memory card holder (3, 4).
- 5 Replace the battery and the back cover.

Remove the memory card

- 1 Remove the back cover and the battery.
- 2 Open the memory card holder, and remove the memory card. Close the memory card holder.
- 3 Replace the battery and the back cover.

Charge the battery

Keep the device dry. If your device does get wet, allow the device to dry completely before connecting the charger.

Your battery has been partially charged at the factory. If the device indicates a low charge, do the following:

- 1 Connect the charger to a wall outlet.

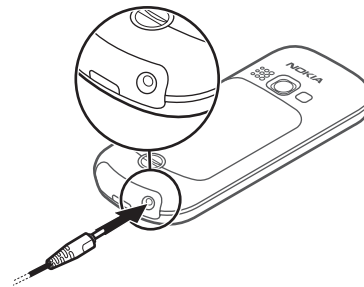

- 2 Connect the charger to the device.
- 3 When the device indicates a full charge, disconnect the charger from the device, then from the wall outlet.

You do not need to charge the battery for a specific length of time, and you can use the device while it is charging. If the battery is completely discharged, it may take several minutes before the charging indicator appears on the display or before any calls can be made.

Antenna



Your device may have internal and external antennas. As with any radio transmitting device, avoid touching the antenna area unnecessarily while the antenna is transmitting or receiving. Contact with such an antenna affects the communication quality and may cause the device to operate at a higher power level than otherwise needed and may reduce the battery life.

The figure shows the antenna area marked in grey.

Accessories

Keep the device dry. If your device does get wet, allow the device to dry completely before connecting an accessory.

If attached, remove the charger from the device before opening the connector cover.

Connect a USB cable

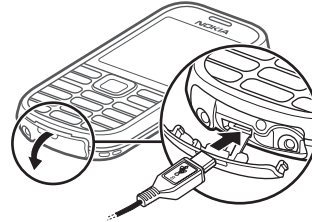

Open the cover of the USB connector, and connect the USB cable to the device.

Headset

Warning: Listen to music at a moderate level. Continuous exposure to high volume may damage your hearing. Do not hold the device near your ear when the loudspeaker is in use, because the volume may be extremely loud.

Warning: When you use the headset, your ability to hear outside sounds may be affected. Do not use the headset where it can endanger your safety.

When connecting any external device or any headset, other than those approved by Nokia for use with this device, to the Nokia AV Connector, pay special attention to volume levels.

Do not connect products that create an output signal as this may cause damage to the device. Do not connect any voltage source to the Nokia AV Connector.

10 Switch it on

Strap

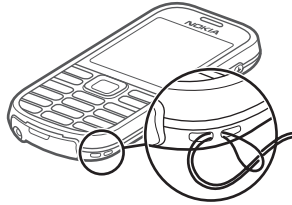

Thread a strap as shown in the picture and tighten it.

Switch it on

Learn how to switch on your phone, and how to use the basic functions.

About your device

The wireless device described in this guide is approved for use on the GSM 900, 1800, and 1900 MHz networks. Contact your service provider for more information about networks.

Your device may have preinstalled bookmarks and links for third-party internet sites and may allow you to access third-party sites. These are not affiliated with Nokia, and Nokia does not endorse or assume liability for them. If you access such sites, take precautions for security or content.

Warning:

To use any features in this device, other than the alarm clock, the device must be switched on. Do not switch the device on when wireless device use may cause interference or danger.

When using this device, obey all laws and respect local customs, privacy and legitimate rights of others, including copyrights. Copyright protection may prevent some images, music, and other content from being copied, modified, or transferred.

Make back-up copies or keep a written record of all important information stored in your device.

When connecting to any other device, read its user guide for detailed safety instructions. Do not connect incompatible products.

The images in this guide may differ from your device display.

Refer to the user guide for other important information about your device.

Network services

To use the device you must have service from a wireless service provider. Many of the features require special network features. These features are not available on all networks; other networks may require that you make specific arrangements with your service provider before you can use the network services. Using network services involves transmission of data. Check with your service provider for details about fees in your home network and when roaming on other networks. Your service provider can give you instructions and explain what charges will apply. Some networks may have limitations that affect how you can use network services. For instance, some networks may not support all language-dependent characters and services.

Your service provider may have requested that certain features be disabled or not activated in your device. If so, these features will not appear on your device menu. Your device may also have a special configuration such as changes in menu names, menu order, and icons. Contact your service provider for more information.

Access codes

To set how your phone uses the access codes and security settings, select **Menu > Settings > Security > Access codes**.

- The security code helps to protect your phone against unauthorised use. The preset code is 12345. You can change the code and set the phone to request the code. Some operations require the security code regardless of the settings, for example if you want

to restore the factory settings. Keep the code secret and in a safe place separate from your phone. If you forget the code and your phone is locked, your phone will require service and additional charges may apply. For more information, contact a Nokia Care point or your phone dealer.

- The PIN (UPIN) code, supplied with the SIM (USIM) card, helps to protect the card against unauthorised use.
- The PIN2 (UPIN2) code, supplied with some SIM (USIM) cards, is required to access certain services.
- PUK (UPUK) and PUK2 (UPUK2) codes may be supplied with the SIM (USIM) card. If you enter the PIN code incorrectly three times in succession, you are asked for the PUK code. If the codes are not supplied, contact your service provider.
- The barring password is required when using the call barring service to restrict calls to and from your phone (network service).
- To view or change the security module settings for the browser, select **Menu > Settings > Security > Security module sett..**

12 Switch it on

Switch the device on and off

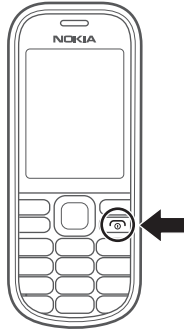

Switch on and off

Press and hold the power key.

Enter the PIN code

If requested, enter the code PIN code (displayed as ****).

Set the time and date

If requested, enter the date, the local time, and the time zone and the daylight saving time of your location.









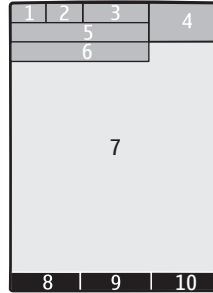

When you switch on your device for the first time, you may be prompted to get the configuration settings from your service provider (network service). For more information, contact your service provider.

Standby mode

When the device is ready for use, and you have not entered any characters, the device is in the standby mode.

Display



- 1 Signal strength of the cellular network 
- 2 Battery charge status 
- 3 Indicators 
- 4 Clock 
- 5 Name of the network or the operator logo 
- 6 Date 
- 7 Display 
- 8 Function of the left selection key 
- 9 Function of the Navi key; hereafter referred to as scroll key 
- 10 Function of the right selection key 

You may change the function of the left and right selection key. See "Left and right selection keys", p. 17.

Power saving

Your phone has a **Power saver** and a **Sleep mode** feature in order to save battery power in the standby mode when no keys are pressed. These features may be activated. See "Display", p. 17.

Home screen

The home screen displays a list of selected features and information that you can directly access.

Select Menu > Settings > Display > Home screen.

Activate the home screen
Select Home screen mode.

Organise and personalise the home screen
Select Personalise view.

Select a key to activate the home screen
Select Home screen key.

Navigate in the home screen
Scroll up or down to navigate in the list, and select **Select**, **View**, or **Edit**. The arrows indicate that further information is available.

Stop navigating
Select Exit.

Shortcuts

When your device is in the standby or home screen mode, you can use the following shortcuts.

List missed, received, and dialled calls
Press the call key. To make a call, scroll to the number or name, and press the call key.















Start the web browser
Press and hold 0.

Call the voice mailbox
Press and hold 1.

Use other keys as shortcuts
See "Dialling shortcuts", p. 22.

Indicators

 You have unread messages.

-  You have unsent, cancelled, or failed messages.
-  The keypad is locked.
-  The device does not ring for incoming calls or text messages.
-  An alarm is set.
-  The device is registered to the GPRS or EGPRS network.
-  The device has an open GPRS or EGPRS connection.
-  The GPRS or EGPRS connection is suspended (on hold).
-  Bluetooth connectivity is turned on.
-  The device receives a GPS signal (external GPS antenna necessary).
-  The device does not receive a GPS signal (external GPS antenna necessary).
-  If you have two phone lines, the second phone line is selected.
-  All incoming calls are diverted to another number.
-  Calls are limited to a closed user group.
-  The currently active profile is timed.
-  The torch function is activated.

Navigate the menus

The phone offers you an extensive range of functions that are grouped into menus.

- 1 To access the menu, select **Menu**.
- 2 Scroll through the menu, and select an option (for example, **Settings**).
- 3 If the selected menu contains further submenus, select one (for example, **Call**).
- 4 Select the setting of your choice.
- 5 To return to the previous menu level, select **Back**.
To exit the menu, select **Exit**.



14 Switch it on

To change the menu view, select **Options** > **Main menu view**. Scroll right, and select from the available options.

To rearrange the menu, select **Options** > **Organise**. Scroll to the menu item to be moved, and select **Move**. Scroll to where you want to move the menu item, and select **OK**. To save the change, select **Done** > **Yes**.

Torch

The camera flash can be used as a torch.

Switch the torch on

In the standby or home screen mode, press and hold the  key. The keypad needs to be unlocked.

Do not direct the torch on eyes at close range.

The torch switches off automatically in the following cases:

- The battery is low
- After 30 minutes
- During incoming or outgoing calls
- When you activate the camera

After the call, or after you deactivate the camera, the torch is not automatically switched back on.

Keypad lock

To lock the keypad to prevent accidental keypresses, select **Menu**, and press * within 3.5 seconds.

To unlock the keypad, select **Unlock**, and press * within 1.5 seconds. If requested, enter the lock code.

To answer a call when the keypad is locked, press the call key. When you end

or reject the call, the keypad locks automatically.

Further features are automatic keyguard and security keyguard. See "Phone", p. 15.

When the device or keypad is locked, calls may be possible to the official emergency number programmed into your device.

Functions without a SIM card

Some functions of your phone may be used without inserting a SIM card, such as Organiser functions and games. Some functions appear dimmed in the menus and cannot be used.

Flight profile

Use the Flight profile in radio sensitive environments to deactivate all radio frequency functions. You still have access to offline games, the calendar, and phone numbers. When the Flight profile is active,  is displayed.

Activate the Flight profile

Select **Menu** > **Settings** > **Profiles** > **Flight** > **Activate** or **Personalise**.

Deactivate the Flight profile

Select any other profile.



Warning:

With the flight profile you cannot make or receive any calls, including emergency calls, or use other features that require network coverage. To make calls, you must first activate the phone function by changing profiles. If the device has been locked, enter the lock code.

If you need to make an emergency call while the device is locked and in the flight profile, you may be also able to enter an official emergency number programmed in your device in the lock code field and select 'Call'. The device will confirm that you are about to exit flight profile to start an emergency call.

Make it your device

Set up your device, personalise it, and connect it in several ways.

Basic settings

Phone

Select **Menu > Settings > Phone** and from the following:

Language settings — to set the language of your phone, select **Phone language** and a language. To set the language of your phone according to the information on the SIM card, select **Phone language > Automatic**.

Memory status — to check the memory consumption

Automatic keyguard — to lock the keypad automatically after a preset time delay when the phone is in the home screen mode and no function has been used

Security keyguard — to ask for the security code when you unlock the keyguard

Voice recognition — See "Voice commands", p. 17.

Flight query — to be asked whether to use the flight mode when you switch the phone on. With flight mode, all radio connections are switched off.

Phone updates — to receive software updates from your service provider (network service). The available options may vary. See "Software updates over the air", p. 40.

Operator selection — to set a cellular network available in your area

Help text activation — to set the phone to show help texts

Start-up tone — to play a tone when you switch the phone on



16 Make it your device

Security

When security features that restrict calls are in use (such as call barring, closed user group, and fixed dialling), calls may be possible to the official emergency number programmed into your device.

Select **Menu > Settings > Security** and from the following:

PIN code request or UPIN code request — to request for your PIN or UPIN code every time the phone is switched on. Some SIM cards do not allow the code request to be turned off.

Call barring service — to restrict incoming calls to and outgoing calls from your phone (network service). A barring password is required.

Fixed dialling — to restrict your outgoing calls to selected phone numbers if supported by your SIM card. When the fixed dialling is on, GPRS connections are not possible except while sending text messages over a GPRS connection. In this case, the recipient's phone number and the message centre number must be included in the fixed dialling list.

Closed user group — to specify a group of people whom you can call and who can call you (network service)

Security level — to request the security code whenever a new SIM card is inserted into the phone, select **Phone**.

Access codes — to change the security code, PIN code, UPIN code, PIN2 code, or barring password

PIN2 code request — to select whether the PIN2 code is required when using a specific phone feature which is protected by the PIN2 code. Some SIM cards do not allow the code request to be turned off. This option may not be available depending on your SIM card. For details, contact your network operator.

Code in use — to select the type of PIN code

Authority certificates or User certificates — to view the list of the authority or user certificates downloaded into your phone. See "Browser security", p. 33.

Security module sett. — to view Secur. module details, activate **Module PIN request**, or change the module PIN and signing PIN. See "Access codes", p. 11.

Personalise your phone

Give your phone a personal touch with ringing tones, display backgrounds, and themes. Add shortcuts for your preferred features, and attach enhancements.

Profiles

Your phone has various setting groups called profiles, which you can customise with ringing tones for different events and environments.

Select **Menu > Settings > Profiles**, the desired profile, and from the following options:

Activate — to activate the selected profile

Personalise — to change the profile settings

Timed — to set the profile to be active for a certain time. When the time set for the profile expires, the previous profile that was not timed becomes active.

Themes

A theme contains elements for personalising your phone.

Select **Menu > Settings > Themes** and from the following options:

Select theme — Open the **Themes** folder, and select a theme.

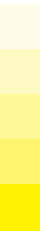

Theme downloads — Open a list of links to download more themes.

Tones

You can change the tone settings of the selected active profile.

Select **Menu** > **Settings** > **Tones**. You can find the same settings in the **Profiles** menu.

If you select the highest ringing tone level, the ringing tone reaches its highest level after a few seconds.

Display

Select **Menu** > **Settings** > **Display** and from the following:

Wallpaper — to add a background image for the home screen mode

Home screen — to activate, organise, and personalise the home screen mode

Home screen font col. — to select the font colour for the home screen mode

Navigation key icons — to display the scroll key icons in the home screen mode

Notification details — to display details in missed call and message notifications

Screen saver — to create and set a screen saver

Power saver — to dim the display automatically, and to display a clock when the phone is not used for a certain length of time

Sleep mode — to switch off the display automatically when the phone is not used for a certain length of time

Font size — to set the font size for messaging, contacts, and web pages

Operator logo — to display the operator logo

Cell info display — to display the cell identity, if available from the network

My shortcuts

With personal shortcuts, you get quick access to frequently used functions of your phone.

Left and right selection keys

To change the function assigned to the left or right selection key, select **Menu** > **Settings** > **My shortcuts** > **Left selection key** or **Right selection key**, and the desired function.

In the home screen mode, if the left selection key is **Go to**, to activate a function, select **Go to** > **Options** and from the following:

Select options — to add or remove a function

Organise — to rearrange the functions

Other shortcuts

Select **Menu** > **Settings** > **My shortcuts** and from the following:

Navigation key — to assign other functions from a predefined list to the navigation key (scroll key)

Home screen key — to select the movement of the navigation key to activate the home screen mode

Assign dialling shortcuts

- 1 Select **Menu** > **Contacts** > **Speed dials**, and scroll to a number key.
- 2 Select **Assign**, or, if a number has already been assigned to the key, select **Options** > **Change**.
- 3 Enter a number or search for a contact.

Voice commands

You can use voice commands to make phone calls, launch applications, and activate profiles.





18 Make it your device

Select **Menu > Settings > Phone**.

Voice commands are language-dependent. To set the language, select **Language settings > Phone language** and the language.

To train the voice recognition of your device to your voice, select **Voice recognition > Voice recog. training**.

To activate a voice command for a function, select **Voice recognition > Voice commands**, a feature, and the function.  indicates that the voice command is activated.

To activate the voice command, select **Add**.

To play the activated voice command, select **Play**.

To use voice commands, see "Voice dialling", p. 22.

To manage voice commands, scroll to a function, select **Options** and from the following:

Edit or Remove — to rename or deactivate the voice command

Add all or Remove all — to activate or deactivate voice commands for all functions in the voice commands list

Connect

Your phone provides several features to connect to other devices to transmit and receive data.

Bluetooth wireless technology

Bluetooth technology allows you to connect your device, using radio waves, to a compatible Bluetooth device within 10 metres (32 feet).

This device is compliant with Bluetooth Specification 2.1 + EDR supporting the following profiles: SIM access, object push, file transfer, dial-up networking, headset, handsfree, generic access, serial port, generic object exchange, advanced audio distribution, audio video remote control, generic audio/video delivery, service discovery application, personal area networking, and phonebook access. To ensure interoperability between other devices supporting Bluetooth technology, use Nokia approved accessories for this model. Check with the manufacturers of other devices to determine their compatibility with this device.

Features using Bluetooth technology increase the demand on battery power and reduce the battery life.

When the wireless device is in the remote SIM mode, you can only use a compatible connected accessory, such as a car kit, to make or receive calls.

Your wireless device will not make any calls, except to the emergency numbers programmed into your device, while in this mode.

To make calls from your device, you must first leave the remote SIM mode. If the device has been locked, enter the lock code to unlock it first.

Open a Bluetooth connection

- 1 Select **Menu > Settings > Connectivity > Bluetooth**.
- 2 Select **My phone's name**, and enter a name for your device.
- 3 To activate Bluetooth connectivity, select **Bluetooth > On**.  indicates that Bluetooth connectivity is active.
- 4 To connect your device to an audio accessory, select **Conn. to audio acc.** and the accessory.

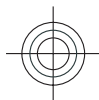

- 5 To pair your device with any Bluetooth device in range, select **Paired devices > Add new device.**
- 6 Scroll to a found device, and select **Add.**
- 7 Enter a passcode (up to 16 characters) on your device, and allow the connection on the other Bluetooth device.

Operating the device in hidden mode is a safer way to avoid malicious software. Do not accept Bluetooth connectivity from sources you do not trust. Alternatively, switch off the Bluetooth function. This does not affect other functions of the device.

Connect your PC to the internet

You can use Bluetooth technology to connect your compatible PC to the internet. Your device must be able to connect to the internet (network service), and your PC must support Bluetooth technology. After connecting to the network access point (NAP) service of the device and pairing with your PC, your device automatically opens a packet data connection to the internet.

Packet data

General packet radio service (GPRS) is a network service that allows mobile phones to send and receive data over an internet protocol (IP)-based network.

To define how to use the service, select **Menu > Settings > Connectivity > Packet data > Packet data conn.** and from the following options:

When needed — to establish the packet data connection when an application needs it. The connection is closed when the application is terminated.

Always online — to automatically connect to a packet data network when you switch the phone on

You can use your phone as a modem by connecting it to a compatible PC using Bluetooth technology. For details, see the Nokia PC Suite documentation.

USB data cable

You can use the USB data cable to transfer data between the phone and a compatible PC or a printer supporting PictBridge.

To activate the phone for data transfer or image printing, connect the data cable and select the mode:

PC Suite — to use the cable for Nokia PC Suite

Printing & media — to use the phone with a PictBridge compatible printer or with a compatible PC

Data storage — to connect to a PC that does not have Nokia software and use the phone as data storage

To change the USB mode, select **Menu > Settings > Connectivity > USB data cable** and the desired USB mode.

Synchronisation and backup

Select **Menu > Settings > Sync and backup** and from the following:

Phone switch — Synchronise or copy selected data between your phone and another phone using Bluetooth technology.

Create backup — Create a backup of selected data.

Restore backup — Select a stored backup file, and restore it to the phone. Select **Options > Details** for information about the selected backup file.

Data transfer — Synchronise or copy selected data between your phone and





20 Make it your device

another device, PC, or network server (network service).

Connect a USB device

You can connect a USB storage (for example, a memory stick) to your device and browse in the file system and transfer files.

- 1 Connect a compatible adapter cable to the USB port of your device.
- 2 Connect the USB storage to the adapter cable.
- 3 Select **Menu > Gallery** and the USB device to browse.

Note: Not all USB storage devices are supported, depending on their power consumption.

Network provider services

Your network provider provides several additional services you may want to use. For some of these services, charges may apply.

Operator menu

Access a portal to services provided by your network operator. For more information, contact your network operator. The operator can update this menu with a service message.

SIM services

Your SIM card may provide additional services. You can access this menu only if it is supported by your SIM card. The name and contents of the menu depend on the available services.

Accessing these services may involve sending messages or making a phone call for which you may be charged.

Info messages, SIM messages, and service commands

Info messages

You can receive messages on various topics from your service provider (network service). For more information, contact your service provider.

Select **Menu > Messaging > Info messages** and from the available options.

Service commands

Service commands allow you to write and send service requests (USSD commands) to your service provider, such as activation commands for network services.

To write and send the service request, select **Menu > Messaging > Serv. commands**. For details, contact your service provider.

SIM messages

SIM messages are specific text messages that are saved to your SIM card. You can copy or move those messages from the SIM to the phone memory, but not vice versa.

To read SIM messages, select **Menu > Messaging > Options > SIM messages**.

Configuration

You can configure your device with settings that are required for certain services. You may receive these settings as a configuration message from your service provider.

Select **Menu > Settings > Configuration** and from the following:

Default config. sett. — View the service providers saved in the device, and set a default service provider.

Act. def. in all apps. — Activate the default configuration settings for supported applications.



Preferred access pt. — View saved access points.

Device manager sett. — Allow or prevent the device from receiving software updates. This option may not be available, depending on your device.

Personal config. sett. — Add new personal accounts for various services manually, and activate or delete them. To add a new personal account, select **Add**, or **Options** > **Add new**. Select the service type, and enter the required details. To activate a personal account, select **Options** > **Activate**.

Stay in touch

Learn how to make calls, write text, send messages, and use the e-mail functionality of your device.

Make calls

Make a voice call

Dial a number manually

Enter the phone number, including the area code, and press the call key.

For international calls, press * twice for the international prefix (the + character replaces the international access code), enter the country code, the area code without the leading 0, if necessary, and the phone number.

Redial a number

To access the list of dialled numbers, in the standby mode, press the call key. Select a number or name, and press the call key.

Call a contact

Select **Menu** > **Contacts and Names**. Select a contact, and press the call key.

Handle voice calls

Answer an incoming call

Press the call key.

End a call

Press the end key.

Mute the ringing tone

Select **Silence**.

Reject an incoming call

Press the end key.

Adjust the volume in a call

Use the volume keys.

22 Stay in touch

Dialling shortcuts

Use a dialling shortcut to make a call in one of the following ways:

- Press a number key, then the call key.
- If **Menu > Settings > Call > Speed dialling > On** is selected, press and hold a number key.

Voice dialling

Make a phone call by saying the name that is saved in Contacts.

As voice commands are language-dependent, before voice dialling, you must select **Menu > Settings > Phone > Language settings > Phone language** and your language.

Note: Using voice tags may be difficult in a noisy environment or during an emergency, so you should not rely solely upon voice dialling in all circumstances.

- 1 In the home screen mode, press and hold the right selection key. A short tone sounds, and **Speak after the tone** is displayed.
- 2 Say the name of the contact you want to dial. If the voice recognition is successful, a list with matches is shown. The phone plays the voice command of the first match on the list. If it is not the correct command, scroll to another entry.

Options during a call

Many of the options that you can use during a call are network services. For availability, contact your service provider.

During a call, select **Options** and from the available options.

Some of the network options are **Hold**, **New call**, **Add to conference**, **End all calls**, and the following:

Send DTMF — to send tone strings

Swap — to switch between the active call and the call on hold

Transfer — to connect a call on hold to an active call and disconnect yourself

Conference — to make a conference call

Private call — to have a private discussion in a conference call

Warning:

Do not hold the device near your ear when the loudspeaker is in use, because the volume may be extremely loud.

Voice messages

The voice mailbox is a network service to which you may need to subscribe. For more information, contact your service provider.

Call your voice mailbox

Press and hold **1**.

Edit your voice mailbox number

Select **Menu > Messaging > Voice messages > Voice mailbox no..**

Call log

To view the information on your calls, messages, data, and synchronisation, select **Menu > Log** and from the available options.

Note: The actual invoice for calls and services from your service provider may vary, depending on network features, rounding off for billing, taxes, and so forth.

Call settings

Select **Menu > Settings** and **Call** and from the following:

Call divert — Divert your incoming calls (network service). You may not be able to

divert your calls if some call barring functions are active.

Anykey answer — Answer an incoming call by briefly pressing any key, except the power key, the left and right selection keys, or the end key.

Automatic redial — The device redials the number automatically if a call fails. The device tries to call the number 10 times.

Voice clarity — Improve speech intelligibility, especially in noisy environments.

Speed dialling — Dial the names and phone numbers assigned to the number keys (2-9) by pressing and holding the corresponding number key.

Call waiting — The network notifies you of an incoming call while you have a call in progress (network service).

Call duration display — Display the duration of the call in progress.

Summary after call — Briefly display the approximate duration after each call.

Send my caller ID — Show your phone number to the person you are calling (network service). To use the setting agreed upon with your service provider, select **Set by network**.

Outgoing call line — Select the phone line for making calls, if your SIM card supports multiple phone lines (network service).



Text and messages

Write text, and create messages and notes.

Write text

Text modes

To enter text (for example, when writing messages) you can use traditional or predictive text input.

When you write text, press and hold **Options** to switch between traditional text input, indicated by , and predictive text input, indicated by . Not all languages are supported by predictive text input.

The character cases are indicated by *Abc*, *abc*, and *ABC*.

To change the character case, press **#**. To change from the letter to number mode, indicated by 123, press and hold **#**, and select **Number mode**. To change from the number to the letter mode, press and hold **#**.

To set the writing language, select **Options > Writing language**.

Traditional text input

Press a number key, 2-9, repeatedly until the desired character appears. The available characters depend on the selected writing language.

If the next letter you want is located on the same key as the present one, wait until the cursor appears, and enter the letter.

To access the most common punctuation marks and special characters, press **1** repeatedly. To access the list of special characters, press *****. To insert a space, press **0**.

Predictive text input

Predictive text input is based on a built-in dictionary to which you can also add new words.

- 1 Start writing a word, using the keys **2 to 9**. Press each key only once for one letter.
- 2 To confirm a word, scroll right or add a space.





24 Stay in touch

- If the word is not correct, press * repeatedly, and select the word from the list.
 - If the ? character is displayed after the word, the word you intended to write is not in the dictionary. To add the word to the dictionary, select **Spell**. Enter the word using traditional text input, and select **Save**.
 - To write compound words, enter the first part of the word, and scroll right to confirm it. Write the last part of the word, and confirm the word.
- 3 Start writing the next word.

Text and multimedia messages

You can create a message and optionally attach, for example, a picture. Your phone automatically changes a text message to a multimedia message when a file is attached.

Text messages

Your device supports text messages beyond the limit for a single message. Longer messages are sent as two or more messages. Your service provider may charge accordingly. Characters with accents or other marks, and characters from some language options, take up more space, and limit the number of characters that can be sent in a single message.

The total number of characters left and the number of messages needed for sending are displayed.

To send messages, the correct message centre number must be stored in your device. Normally, this number is set by default through your SIM card. To set the number manually, select **Menu > Messaging > Message settings > Text**

messages > Message centres > Add centre, and enter a name and the number from the service provider.

Multimedia messages

A multimedia message can contain text, pictures, and sound or video clips.

Only devices that have compatible features can receive and display multimedia messages. The appearance of a message may vary depending on the receiving device.

The wireless network may limit the size of MMS messages. If the inserted picture exceeds this limit the device may make it smaller so that it can be sent by MMS.

Important: Exercise caution when opening messages. Messages may contain malicious software or otherwise be harmful to your device or PC.

For availability and subscription to the multimedia messaging service (MMS), contact your service provider.

Create a text or multimedia message

- 1 Select **Menu > Messaging > Create message > Message**.
- 2 To add recipients, scroll to the **To:** field, and enter the recipient's number or e-mail address, or select **Add** to select recipients from the available options. Select **Options** to add recipients and subjects and to set sending options.
- 3 Scroll to the **Text:** field, and enter the message text.
- 4 To attach content to the message, scroll to the attachment bar at the bottom of the display and select the desired type of content.
- 5 To send the message, press **Send**.



The message type is indicated at the top of the display and changes automatically depending on the content of the message.

Service providers may charge differently depending on the message type. Check with your service provider for details.

Read a message and reply

Important: Exercise caution when opening messages. Messages may contain malicious software or otherwise be harmful to your device or PC.

Your phone issues a notification when you receive a message. Select **View** to display the message. If more than one message was received, to display a message, select the message from the Inbox and **Open**. Use the scroll key to view all parts of the message.

To create an answer message, select **Reply**.

Send and organise messages

To send a message, select **Send**. The phone saves the message in the Outbox folder, and the sending starts.

Note: The message sent icon or text on your device screen does not indicate that the message is received at the intended destination.

If message sending is interrupted, the phone tries to resend the message a few times. If these attempts fail, the message remains in the Outbox folder. To cancel message sending, in the Outbox folder, select **Options** > **Cancel sending**.

To save the sent messages in the Sent items folder, select **Menu** > **Messaging** > **Message settings** > **General settings** > **Save sent messages**.

The phone saves received messages in the Inbox folder. Organise your messages in the Saved items folder.

To add, rename, or delete a folder, select **Menu** > **Messaging** > **Saved items** > **Options**.

Flash messages

Flash messages are text messages that are instantly displayed upon reception.

- 1 To write a flash message, select **Menu** > **Messaging** > **Create message** > **Flash message**.
- 2 Enter the recipient's phone number, write your message (maximum 70 characters), and select **Send**.

Instant messaging

With instant messaging (IM, network service) you can send short text messages to online users. You must subscribe to a service and register with the IM service you want to use. Check the availability of this service, pricing, and instructions with your service provider. The menus may vary depending on your IM provider.

To connect to the service, select **Menu** > **IM** and follow the instructions on the display.

Nokia Xpress audio messages

Create and send an audio message using MMS in a convenient way.

- 1 Select **Menu** > **Messaging** > **Create message** > **Audio message**. The voice recorder opens.
- 2 Record your message. See "Voice recorder", p. 31.
- 3 Enter one or more phone numbers in the **To:** field, or select **Add** to retrieve a number.
- 4 To send the message, select **Send**.

Message settings

Select **Menu** > **Messaging** > **Message settings** and from the following:

General settings — to save copies of sent messages in your phone, to overwrite old messages if the message memory becomes full, and to set up other preferences related to messages

Text messages — to allow delivery reports, to set up message centres for SMS and SMS e-mail, to select the type of character support, and to set up other preferences related to text messages

Multimedia messages — to allow delivery reports, to set up the appearance of multimedia messages, to allow the reception of multimedia messages and advertisements, and to set up other preferences related to multimedia messages

Service messages — to activate service messages and to set up preferences related to service messages

E-mail

Access your POP3 or IMAP4 e-mail account with your phone to read, write, and send e-mail. This e-mail application is different from the SMS e-mail function.

Before you can use e-mail, you must have an e-mail account and the correct settings. For availability and the correct settings, contact your e-mail service provider.

E-mail setup wizard

The e-mail setup wizard starts automatically if no e-mail settings are defined in the phone. To start the setup wizard for an additional e-mail account, select **Menu** > **Messaging** and the existing e-mail account. Select **Options** > **Add mailbox** to start the e-mail setup wizard. Follow the instructions on the display.

Write and send an e-mail

You may write your e-mail before connecting to the e-mail service.

- 1 Select **Menu** > **Messaging** > **Create message** > **E-mail message**.
- 2 Enter the recipient's e-mail address, the subject, and the e-mail message. To attach a file, select **Options** > **Insert** and from the available options.
- 3 If more than one e-mail account is defined, select the account from which you want to send the e-mail.
- 4 To send the e-mail, select **Send**.

Read an e-mail and reply

Important: Exercise caution when opening messages. Messages may contain malicious software or otherwise be harmful to your device or PC.

- 1 To download e-mail message headers, select **Menu** > **Messaging** and your e-mail account.
- 2 To download an e-mail and its attachments, select the e-mail and **Open** or **Retrieve**.
- 3 To reply to or forward the e-mail, select **Options** and from the available options.
- 4 To disconnect from your e-mail account, select **Options** > **Disconnect**. The connection to the e-mail account automatically ends after some time without activity.

New e-mail notifications

Your phone can automatically check your e-mail account in time intervals and issue a notification when new e-mail is received.

- 1 Select **Menu** > **Messaging** > **Message settings** > **E-mail messages** > **Edit mailboxes**.



- 2 Select your e-mail account, **Downloading sett.**, and the following options:

Mailbox upd. interval — to set how often your phone checks your e-mail account for new e-mail

Automatic retrieval — to retrieve new e-mail automatically from your e-mail account

- 3 To enable the new e-mail notification, select **Menu > Messaging > Message settings > E-mail messages > New e-mail notif. > On**.

Image and video

Capture an image

Activate the camera

Select **Menu > Media > Camera**; or, if in video mode, scroll left or right.

Zoom in or out

In camera mode, scroll up and down, or use the volume keys.

Capture an image

Select **Capture**.

The device saves the images in Gallery.

Activate the camera flash

To capture all images using the camera flash, select **Options > Flash > Flash on**, or to set the device to use the flash automatically in dim lighting conditions, select **Automatic**.

Keep a safe distance when using the flash. Do not use the flash on people or animals at close range. Do not cover the flash while taking a picture.

Preview an image

To display an image immediately after you capture it, select **Options > Settings > Image preview time** and the preview time. During the preview time, select **Back** to capture another image, or **Send** to send the image as a multimedia message.

Your device supports an image capture resolution of up to 1200x1600 pixels.

Record a video clip

Activate video mode

Select **Menu > Media > Video recorder**, or, if in image mode, scroll left or right.





28 Image and video

Start recording a video clip

To start and control recording, select **Record, Pause, and Continue**.

Stop recording

Select **Stop**.

The video clips are saved in Gallery.

Camera and video options

In the camera or video mode, select **Options** and from the following:

Effects — Apply different effects (for example, greyscale and false colour) to the captured image.

White balance — Adapt the camera to the current light conditions.

Settings — Change other camera and video settings, and select the image and video storage.

Gallery

Manage images, video clips, music files, themes, graphics, tones, recordings, and received files. These files are stored in the phone memory or on a memory card and may be arranged in folders.

Folders and files

- 1 To view the list of folders, select **Menu > Gallery**.
- 2 To view the list of files in a folder, select a folder and **Open**.
- 3 To view the folders of the memory card when moving a file, scroll to the memory card, and press the scroll key right.

Print images

Your phone supports Nokia XpressPrint to print images that are in the jpeg format.

- 1 To connect your phone to a compatible printer, use a data cable

or send the image by Bluetooth to a printer supporting Bluetooth technology. See "Bluetooth wireless technology", p. 18.

- 2 Select the image you want to print and **Options > Print**.

Share images and videos online

Share images and video clips in compatible online sharing services on the web.

To use online sharing, you must subscribe to an online sharing service (network service).

To upload an image or a video clip to an online sharing service, select the file from **Gallery, Options > Send > Upload to web**, and an online sharing service.

For more information on online sharing and compatible service providers, see the Nokia product support pages or your local Nokia website.

You can view uploads on the internet pages of the online sharing service on your device. See "Web uploads", p. 32.

Memory card

Use a memory card to store your multimedia files, such as video clips, songs, sound files, images, and messaging data.

Some of the folders in Gallery with content used by the phone (for example, Themes) may be stored on the memory card.

Format the memory card

Some supplied memory cards are pre-formatted; others require formatting. When you format a memory card, all data on the card is permanently lost.

- 1 To format a memory card, select **Menu > Gallery or Applications, the**

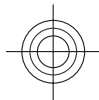

memory card folder, and **Options > Format memory card > Yes.**

- When formatting is complete, enter a name for the memory card.

Lock the memory card

To set a password (maximum 8 characters) to lock your memory card against unauthorised use, select the memory card folder and **Options > Set password.**

The password is stored in your phone, and you do not have to enter it again while you are using the memory card in the same phone. If you want to use the memory card in another device, you are asked for the password.

To remove the password, select **Options > Delete password.**

Check memory consumption

To check the memory consumption of different data groups and the available memory to install new software to your memory card, select the memory card and **Options > Details.**

Entertainment

Listen to music

Listen to music with the music player or radio, and record sounds or voice with the voice recorder. Download music from the internet, or transfer music from your PC.

Media player

Your phone includes a media player for listening to songs and viewing video clips. Music and video files stored in the music folder in the phone memory or on the memory card are automatically detected and added to the music library.

To open the media player, select **Menu > Media > Media player.**

Music menu

Access your music and video files stored in the device memory or on the memory card, download music or video clips from the web, or view compatible video streams from a network server (network service).

Listen to music or play a video clip

Select a file from the available folders and **Play.**

Download files from the web

Select **Options > Downloads** and a download site.

Update music library after you have added files

Select **Options > Update library.**

Create a playlist

- Select **Playlists > Create playlist**, and enter the name of the playlist.
- Add music or video clips from the displayed lists.
- Select **Done** to store the playlist.





30 Entertainment

Configure a streaming service (network service)

You may receive the streaming settings as a configuration message from your service provider. You can also enter the settings manually. See "Configuration", p. 20.

- 1 Select **Options > Downloads > Streaming settings > Configuration**.
- 2 Select a service provider, **Default**, or **Personal config.** for streaming.
- 3 Select **Account** and a streaming service account from the active configuration settings.

Play songs

Warning:

Listen to music at a moderate level. Continuous exposure to high volume may damage your hearing. Do not hold the device near your ear when the loudspeaker is in use, because the volume may be extremely loud.

To adjust the volume level, press the volume keys.

Operate the player with the virtual keys on the display.

To start playing, select ►.

To pause playing, select ||.

To skip to the next song, select ►►. To skip to the beginning of the previous song, select ◀◀ twice.

To fast-forward the current song, select and hold ►►. To rewind the current song, select and hold ◀◀. Release the key at the position you want to continue the music playback.

To switch to the music menu, select ≡.

To switch to the current playlist, select (••).

To close the media player menu, and to continue music playback in the background, press the end key.

To stop the media player, press and hold the end key.

Change the media player look

Your phone provides several themes to change the look of the media player.

Select **Menu > Media > Media player > Go to Media player > Options > Settings > Media player theme** and one of the listed themes. The virtual keys may change depending on the theme.

Radio

The FM radio depends on an antenna other than the wireless device antenna. A compatible headset or accessory needs to be attached to the device for the FM radio to function properly.

Warning:

Listen to music at a moderate level. Continuous exposure to high volume may damage your hearing. Do not hold the device near your ear when the loudspeaker is in use, because the volume may be extremely loud.

Select **Menu > Media > Radio**.

To adjust the volume, use the volume keys.

Use the graphical keys on the display

Scroll up, down, left, or right.



Close the radio menu
Briefly press the end key. The radio continues playing in the background.

Switch the radio off
Press and hold the end key.

Tune radio stations

- 1 To start the search, press and hold the scroll key left or right. To change the radio frequency in 0.05 MHz steps, briefly press the scroll key left or right.
- 2 To save a station to a memory location, select **Options** > **Save station**.
- 3 To enter the name of the radio station, select **Options** > **Stations** > **Options** > **Rename**.

Select **Options** and from the following:
Search all stations — to automatically search for the available stations at your location
Set frequency — to enter the frequency of the desired radio station
Stations — to list and rename or delete saved stations

Change stations
Scroll up or down, or press the number keys corresponding to the number of the station in the station list.

Radio settings

Select **Options** > **Settings** and from the following:
RDS — to select whether to display information from the radio data system
Auto-frequency — to enable the automatic switch to a frequency with the best reception of the tuned in station (available when RDS is activated)

Play via — to select the headset or the loudspeaker
Output — to switch between stereo and mono output
Radio theme — to select a radio theme

Voice recorder

Record speech, sound, or an active call, and save the recordings in Gallery.
 Select **Menu** > **Media** > **Voice recorder**.
 The recorder cannot be used when a data call or GPRS connection is active.
 To use the graphical keys ●, □, or ■, scroll left or right.

Start recording

Select ●, or, during a call, select **Options** > **Record**. While recording a call, all parties to the call hear a faint beeping.

Pause recording

Select □.

Stop recording

Select ■. The recording is saved in the Recordings folder in Gallery.

To play or send the last recording, to access the list of recordings, or to select the memory and the folder to store the recordings, select **Options** and the appropriate option.

Equaliser

Adjust the sound when using the music player.
 Select **Menu** > **Media** > **Equaliser**.
 To activate a predefined equaliser set, scroll to one of the sets, and select **Activate**.



32 Entertainment

Create a new equaliser set

- 1 Select one of the last two sets in the list and **Options > Edit**.
- 2 Scroll left or right to access the virtual sliders and up or down to adjust the slider.
- 3 To save the settings and create a name for the set, select **Save** and **Options > Rename**.

Stereo widening

Stereo widening creates a wider stereo sound effect when you are using a stereo headset.

To activate, select **Menu > Media > Stereo widening**.

Web

You can access various internet services with your device browser (network service). The appearance of the internet pages may vary due to screen size. You may not be able to see all the details on the internet pages.

Important: Use only services that you trust and that offer adequate security and protection against harmful software.

For the availability of these services, pricing, and instructions, contact your service provider.

You may receive the configuration settings required for browsing as a configuration message from your service provider.

To set up the service, select **Menu > Web > Web settings > Configuration sett.**, a configuration, and an account.

Connect to a service

To make a connection to the service, select **Menu > Web > Home**; or in the standby mode, press and hold **0**.

To select a bookmark, select **Menu > Web > Bookmarks**.

To select the last visited URL, select **Menu > Web > Last web addr.**

To enter the address of a service, select **Menu > Web > Go to address**. Enter the address, and select **OK**.

After you make a connection to the service, you can start browsing its pages. The function of the phone keys may vary in different services. Follow the text guides on the phone display. For more information, contact your service provider.

Web uploads

Open the web page of your online sharing service to view uploaded images and videos and to change settings (network service).

Open an online sharing service

- 1 Select **Menu > Web > Web uploads** and an online sharing service.
- 2 Select from the links offered by the service.

Change settings of an online sharing service

- 1 Select **Menu > Web > Web uploads** and an online sharing service.
- 2 Select **Options > Settings** to open the settings page of the service.

Appearance settings

While browsing the web, select **Options > Settings** and from the following:

Display — Select the font size, whether images are shown, and how the text is displayed.

General — Select whether web addresses are sent as Unicode (UTF-8), the encoding

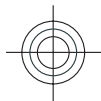

type for the contents, and whether JavaScript™ is enabled.

The available options may vary.

Cache memory

A cache is a memory location that is used to store data temporarily. If you have tried to access or have accessed confidential information requiring passwords, empty the cache after each use. The information or services you have accessed are stored in the cache.

A cookie is data that a site saves in the cache memory of your phone. Cookies are saved until you clear the cache memory.

To clear the cache while browsing, select **Options > Tools > Clear the cache.**

To allow or prevent the phone from receiving cookies, select **Menu > Web > Web settings > Security > Cookies**; or, while browsing, select **Options > Settings > Security > Cookies.**

Browser security

Security features may be required for some services, such as banking services or online shopping. For such connections you need security certificates and possibly a security module, which may be available on your SIM card. For more information, contact your service provider.

To view or change the security module settings, or to view a list of authority or user certificates downloaded to your device, select **Menu > Settings > Security > Security module sett., Authority certificates, or User certificates.**

Important: Even if the use of certificates makes the risks involved in remote connections and software installation considerably smaller, they must be used

correctly in order to benefit from increased security. The existence of a certificate does not offer any protection by itself; the certificate manager must contain correct, authentic, or trusted certificates for increased security to be available. Certificates have a restricted lifetime. If "Expired certificate" or "Certificate not valid yet" is shown, even if the certificate should be valid, check that the current date and time in your device are correct.

Before changing any certificate settings, you must make sure that you really trust the owner of the certificate and that the certificate really belongs to the listed owner.

Games and applications

You can manage applications and games. Your phone may have some games or applications installed. These files are stored in the phone memory or an attached memory card and may be arranged in folders.

Launch an application

Select **Menu > Applications > Games, Memory card, or Collection.** Scroll to a game or an application, and select **Open.**

To set sounds, lights, and shakes for a game, select **Menu > Applications > Options > Application settings.**

Other available options may include the following:

Update version — to verify that a new version of the application is available for download from the web (network service)

Web page — to provide further information or additional data for the application from an internet page (network service), if available





Application access — to restrict the application from accessing the network

Download an application

Your phone supports J2ME™ Java applications. Ensure that the application is compatible with your phone before downloading it.

Important: Only install and use applications and other software from trusted sources, such as applications that are Symbian Signed or have passed the Java Verified™ testing.

You can download new applications and games in different ways.

- Select **Menu > Applications > Options > Downloads > App. downloads** or **Game downloads**; the list of available bookmarks is shown.
- Use the Nokia Application Installer from PC Suite to download the applications to your phone.

For the availability of different services and pricing, contact your service provider.



Maps

You can browse maps for different cities and countries, search for addresses and points of interest, plan routes from one location to another, save locations as landmarks, and send them to compatible devices.

Almost all digital cartography is inaccurate and incomplete to some extent. Never rely solely on the cartography that you download for use in this device.

Note: Downloading maps may involve the transmission of large amounts of data through your service provider's network. Contact your service provider for information about data transmission charges.

Traffic and guide information and related services are generated by third parties independent of Nokia. The information may be inaccurate and incomplete to some extent and is subject to availability. Never rely solely on the aforementioned information and related services.

Find detailed information about Maps on www.nokia.com/maps

To use the Maps application, select **Menu > Organiser > Maps** and from the available options.

Download maps

Your phone may contain pre-installed maps on the memory card. You can download a new set of maps through the internet using the Nokia Map Loader PC software.

Nokia Map Loader

To download the Nokia Map Loader on your PC and for further instructions, see www.maps.nokia.com.





Before you download new maps for the first time, ensure that you have a memory card inserted in the phone.

Select **Menu > Organiser > Maps** to do an initial configuration.

To change the selection of maps on your memory card, use the Nokia Map Loader to delete all maps on the memory card and download a new selection, to ensure that all maps are from the same release.

Network map service

You can set your phone to automatically download maps that you do not have in your phone when needed.

Select **Menu > Organiser > Maps > Settings > Network settings > Allow network usage > Yes** or **In home network**.

To prevent automatic download of maps, select **No**.

Note: Downloading maps may involve the transmission of large amounts of data through your service provider's network. Contact your service provider for information about data transmission charges.

Maps and GPS

You can use the Global Positioning System (GPS) to support the Maps application. Find out your location, or measure distances and plot coordinates.

Before you can use the GPS function with your phone, you must pair your phone with a compatible external GPS receiver using Bluetooth wireless technology. For more information, see the user guide for your GPS device.

After pairing the Bluetooth GPS device with the phone, it may take several

minutes for the phone to display the current location. Subsequent connections should be faster, but if you have not used GPS for several days, or are very far away from the last place you used it, it may take several minutes to detect and display your location.

The Global Positioning System (GPS) is operated by the government of the United States, which is solely responsible for its accuracy and maintenance. The accuracy of location data can be affected by adjustments to GPS satellites made by the United States government and is subject to change with the United States Department of Defense civil GPS policy and the Federal Radionavigation Plan. Accuracy can also be affected by poor satellite geometry. Availability and quality of GPS signals may be affected by your location, buildings, natural obstacles, and weather conditions. The GPS receiver should only be used outdoors to allow reception of GPS signals.

Any GPS should not be used for precise location measurement, and you should never rely solely on location data from the GPS receiver and cellular radio networks for positioning or navigation.

Extra services

You can upgrade Maps to fully voice-guided navigation, which requires a regional licence.

To use this service, you need a compatible external GPS device that supports Bluetooth wireless technology.

To purchase a navigation service with voice guidance, select **Menu > Organiser > Maps > Extra services > Purchase navigation**, and follow the instructions.

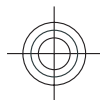



36 Organise

To use navigation with voice guidance, you must allow the Maps application to use a network connection.

The navigation licence is connected to your SIM card. If you insert another SIM card in your phone, you are asked to purchase a licence when starting navigation. During the purchase procedure, you are offered to transfer the existing navigation licence to the new SIM card without extra charge.



Organise

Let your phone help you to organise your life.

Manage contacts

Save names, phone numbers, and addresses as contacts in the phone and on the SIM card.

Select **Menu > Contacts**.

Select the memory for contacts

The phone memory can save contacts with additional details, such as various phone numbers and text items. You can also save an image, a tone, or a video clip for a limited number of contacts.

The SIM card memory can save names with one phone number attached to them. The contacts saved in the SIM card memory are indicated by .

- 1 Select **Settings > Memory in use** to select the SIM card, the phone memory, or both for your contacts.
- 2 Select **Phone and SIM** to recall contacts from both memories. When you save contacts, they are saved in the phone memory.

Handle contacts

Search for a contact

Select **Menu > Contacts > Names**.
Scroll through the list of contacts, or enter the first characters of the contact's name.

Save a name and phone number

Select **Menu > Contacts > Add new**.

Add and edit details

Select a contact and **Details > Options > Add detail**.



Delete a detail

Select a contact and **Details**. Select a detail and **Options** > **Delete**.

Delete a contact

Select a contact and **Options** > **Delete contact**.

Delete all contacts

Select **Menu** > **Contacts** > **Del. all contacts** > **From phone memory** or **From SIM card**.

Copy or move contacts between the phone and SIM card memories**Copy single contacts**

Select **Options** > **Mark** > **Mark**. Mark the contacts you want to copy or move, and select **Options** > **Copy marked** or **Move marked**.

Copy all contacts

Select **Menu** > **Contacts** > **Copy contacts** or **Move contacts**.

Create a contact group

Arrange contacts into caller groups with different ringing tones and group images.

- 1 Select **Menu** > **Contacts** > **Groups**.
- 2 Select **Add** or **Options** > **Add new group** to create a new group.
- 3 Enter the group name, optionally select an image and a ringing tone, and select **Save**.
- 4 Select the group and **View** > **Add** to add contacts to the group.

Business cards

You can send and receive a person's contact information from a compatible device that supports the vCard standard.

To send a business card, search for the contact, and select **Details** > **Options** > **Send business card**.

When you receive a business card, select **Show** > **Save** to save the business card in the phone memory.

Date and time

To change the clock type, time, time zone, or date, select **Menu** > **Settings** > **Date and time**.

When travelling to a different time zone, select **Menu** > **Settings** > **Date and time** > **Date & time settings** > **Time zone**; and scroll left or right to select the time zone of your location. The time and date are set according to the time zone and enable your phone to display the correct sending time of received text or multimedia messages.

For example, GMT -5 denotes the time zone for New York (USA), 5 hours west of Greenwich, London (UK).

Alarm clock

To sound an alarm at a desired time.

Set the alarm

- 1 Select **Menu** > **Organiser** > **Alarm clock**.
- 2 Set the alarm on, and enter the alarm time.
- 3 To issue an alarm on selected days of the week, select **Repeat:** > **On** and the days.
- 4 Select the alarm tone. If you select the radio as the alarm tone, connect the headset to the phone.
- 5 Set the snooze time-out, and select **Save**.

38 Organise

Stop the alarm

To stop the sounding alarm, select **Stop**. If you let the alarm sound for a minute or select **Snooze**, the alarm stops for the snooze time-out, then resumes.

Calendar

Select **Menu > Organiser > Calendar**.

The current day is framed. If there are any notes set for the day, the day is in bold type. To view the day notes, select **View**. To view a week, select **Options > Week view**. To delete all notes in the calendar, select **Options > Delete notes > All notes**.

To edit settings related to date and time, select **Options > Settings** and from the available options. To delete old notes automatically after a specified time, select **Options > Settings > Auto-delete notes** and from the available options.

Make a calendar note

Scroll to the date, and select **Options > Make a note**. Select the note type, and fill in the fields.

To-do list

To create a note for a task that you must do, select **Menu > Organiser > To-do list**.

To create a note if no note is added, select **Add**; otherwise, select **Options > Add**. Fill in the fields, and select **Save**.

To view a note, scroll to it, and select **View**.

Notes

To write and send notes, select **Menu > Organiser > Notes**.

To make a note if no note is added, select **Add**; otherwise, select **Options > Make a note**. Write the note, and select **Save**.

Nokia PC Suite

With Nokia PC Suite, you can manage your music and synchronise contacts, calendar entries, notes, and to-do notes between your device and a compatible PC or a remote internet server (network service). For more information, and to download PC Suite, see www.nokia.com/support.

Calculator

Your phone provides a standard, a scientific, and a loan calculator.

Select **Menu > Organiser > Calculator** and, from the available options, the calculator type and the operating instructions.

This calculator has limited accuracy and is designed for simple calculations.

Countdown timer

Normal timer

- 1 To activate the timer, select **Menu > Organiser > Countd. timer > Normal timer**, enter a time, and write a note that is displayed when the time expires. To change the time, select **Change time**.
- 2 To start the timer, select **Start**.
- 3 To stop the timer, select **Stop timer**.

Interval timer

- 1 To have an interval timer with up to 10 intervals started, first enter the intervals.
- 2 Select **Menu > Organiser > Countd. timer > Interval timer**.
- 3 To start the timer, select **Start timer > Start**.

To select how the interval timer should start the next period, select **Menu > Organiser > Countd. timer > Settings > Contin. to next period** and from the available options.

Stopwatch

You can measure time, take intermediate times, or take lap times using the stopwatch.

Select **Menu > Organiser > Stopwatch** and from the following options:

Split timing — to take intermediate times. To reset the time without saving it, select **Options > Reset**.

Lap timing — to take lap times

Continue — to view the timing that you have set in the background

Show last — to view the most recently measured time if the stopwatch is not reset

View times or Delete times — to view or delete the saved times

To set the stopwatch timing in the background, press the end key.

Support and updates

Nokia helps you in many ways to gain the most benefit from your device.

Support

When you want to learn more about how to use your product or you are unsure how your device should function, see the user guide or see the support pages at www.nokia.com/support or your local Nokia website, or with a mobile device, www.nokia.mobi/support.

If this does not resolve your issue, do the following:

- Restart the device: switch off the device, and remove the battery. After about a minute, replace the battery, and switch on the device.
- With the Nokia Software Updater application, update your device software regularly for optimum performance and possible new features. See www.nokia.com/softwareupdate, or in Latin America, www.nokia-latinoamerica.com/nsu. Remember to back up your device data before updating the device software.
- Restore the original factory settings as explained in the user guide.

If the issue remains unsolved, contact Nokia for repair options. See www.nokia.com/repair, or in Latin America, www.nokia-latinoamerica.com/centrosdeservicio. Before sending your device for repair, always back up the data in your device.

My Nokia

Receive free tips, tricks, and support for your Nokia phone, plus free trial content, interactive demonstrations, a



40 Support and updates

personalised web page, and news about the latest Nokia products and services.

Get the most out of your Nokia phone and register to My Nokia today! For more information and availability in your region, see www.nokia.com/mynokia.

Download content

You may be able to download new content (for example, themes) to your phone (network service).

Important: Use only services that you trust and that offer adequate security and protection against harmful software.

For the availability of different services and pricing, contact your service provider.

Software updates using your PC

Software updates may include new features and enhanced functions that were not available at the time of purchase of your device. Updating the software may also improve the device performance.

Nokia Software Updater is a PC application that enables you to update your device software. To update your device software, you need a compatible PC, broadband internet access, and a compatible USB data cable to connect your device to the PC.

To get more information, to check the release notes for the latest software versions, and to download the Nokia Software Updater application, see www.nokia.com/softwareupdate, or in Latin America, www.nokia-latinoamerica.com/nsu.

To update the device software, do the following:

- 1 Download and install the Nokia Software Updater application to your PC.
- 2 Connect your device to the PC using a USB data cable, and open the Nokia Software Updater application. The Nokia Software Updater application guides you to back up your files, update the software, and restore your files.

Software updates over the air

Your service provider may send phone software updates over the air directly to your phone (network service). This option may not be available, depending on your phone.

Downloading software updates may involve the transmission of large amounts of data through your service provider's network. Contact your service provider for information about data transmission charges.

Make sure that the device battery has enough power, or connect the charger before starting the update.

Warning:

If you install a software update, you cannot use the device, even to make emergency calls, until the installation is completed and the device is restarted. Be sure to back up data before accepting installation of an update.

Software update settings

This option may not be available, depending on your phone.

To allow or disallow software and configuration updates, select **Menu > Settings > Configuration > Device manager sett. > Serv. softw. updates.**



Request a software update

- 1 Select **Menu > Settings > Phone > Phone updates** to request available software updates from your service provider.
- 2 Select **Current softw. details** to display the current software version and check whether an update is needed.
- 3 Select **Downl. phone softw.** to download and install a software update. Follow the instructions on the display.
- 4 If the installation was cancelled after the download, select **Install softw. update** to start the installation.

The software update may take several minutes. If there are problems with the installation, contact your service provider.

Restore factory settings

To restore the phone back to factory conditions, select **Menu > Settings > Rest. factory sett.** and from the following:

Restore settings only — Reset all preference settings without deleting any personal data.

Restore all — Reset all preference settings and delete all personal data, such as contacts, messages, media files, and activation keys.

Green tips

Here are tips on how you can contribute to protecting the environment.

Save energy

When you have fully charged the battery and disconnected the charger from the device, unplug the charger from the wall outlet.

You do not need to charge your battery so often if you do the following:

- Close and disable applications, services, and connections when not in use.
- Decrease the brightness of the screen.
- Set the device to enter the power saver mode after the minimum period of inactivity, if available in your device.
- Disable unnecessary sounds, such as keypad and ringing tones.

Recycle

Most of the materials in a Nokia phone are recyclable. Check how to recycle your Nokia products at www.nokia.com/werecycle, or with a mobile device, www.nokia.mobi/werecycle.

Recycle packaging and user guides at your local recycling scheme.

Learn more

For more information on the environmental attributes of your device, see www.nokia.com/ecodeclaration.



42 Digital rights management

Digital rights management

Content owners may use different types of digital rights management (DRM) technologies to protect their intellectual property, including copyrights. This device uses various types of DRM software to access DRM-protected content. With this device you can access content protected with WMDRM 10, OMA DRM 1.0, OMA DRM 1.0 forward lock, and OMA DRM 2.0. If certain DRM software fails to protect the content, content owners may ask that such DRM software's ability to access new DRM-protected content be revoked. Revocation may also prevent renewal of such DRM-protected content already in your device. Revocation of such DRM software does not affect the use of content protected with other types of DRM or the use of non-DRM-protected content.

Digital rights management (DRM) protected content comes with an associated activation key that defines your rights to use the content.

If your device has OMA DRM-protected content, to back up both the activation keys and the content, use the backup feature of Nokia PC Suite. Other transfer methods may not transfer the activation keys which need to be restored with the content for you to be able to continue the use of OMA DRM-protected content after the device memory is formatted. You may also need to restore the activation keys in case the files on your device get corrupted.

If your device has WMDRM-protected content, both the activation keys and the content will be lost if the device memory is formatted. You may also lose the activation keys and the content if the files on your device get corrupted. Losing the activation keys or the content may limit your ability to use the same content on your device again. For more information, contact your service provider.

Some activation keys may be connected to a specific SIM card, and the protected content can be accessed only if the SIM card is inserted in the device.

Third-party applications

The third-party applications provided with your device may have been created and may be owned by persons or entities not affiliated with or related to Nokia. Nokia does not own the copyrights or intellectual property rights to the third-party applications. As such, Nokia does not take any responsibility for end-user support, functionality of the applications, or the information in the applications or these materials. Nokia does not provide any warranty for the third-party applications.

BY USING THE APPLICATIONS YOU ACKNOWLEDGE THAT THE APPLICATIONS ARE PROVIDED AS IS WITHOUT WARRANTY OF ANY KIND, EXPRESS OR IMPLIED, TO THE MAXIMUM EXTENT PERMITTED BY APPLICABLE LAW. YOU FURTHER ACKNOWLEDGE THAT NEITHER NOKIA NOR ITS AFFILIATES MAKE ANY REPRESENTATIONS OR WARRANTIES, EXPRESS OR IMPLIED, INCLUDING BUT NOT LIMITED TO WARRANTIES OF TITLE, MERCHANTABILITY OR FITNESS FOR A PARTICULAR PURPOSE, OR

THAT THE APPLICATIONS WILL NOT INFRINGE ANY THIRD-PARTY PATENTS, COPYRIGHTS, TRADEMARKS, OR OTHER RIGHTS.

Accessories

Warning:
Use only batteries, chargers, and accessories approved by Nokia for use with this particular model. The use of any other types may invalidate any approval or warranty, and may be dangerous.

For availability of approved accessories, please check with your dealer. When you disconnect the power cord of any accessory, grasp and pull the plug, not the cord.

Battery and charger information

Your device is powered by a rechargeable battery. The battery intended for use with this device is BL-5CT. Nokia may make additional battery models available for this device. This device is intended for use when supplied with power from the following chargers: AC-8. The exact charger model number may vary depending on the type of plug. The plug variant is identified by one of the following: E, EB, X, AR, U, A, C, or UB.

The battery can be charged and discharged hundreds of times, but it will eventually wear out. When the talk and standby times are noticeably shorter than normal, replace the battery. Use only Nokia approved batteries, and recharge your battery only with Nokia approved chargers designated for this device. Use of an unapproved battery or charger may present a risk of fire, explosion, leakage, or other hazard.

If a battery is being used for the first time or if the battery has not been used for a prolonged period, it may be necessary to connect the charger, then disconnect and reconnect it to begin charging the battery. If the battery is completely discharged, it may take several minutes before the charging indicator appears on the display or before any calls can be made.

Always switch the device off and disconnect the charger before removing the battery.

Unplug the charger from the electrical plug and the device when not in use. Do not leave a fully charged battery connected to a charger, since overcharging may shorten its lifetime. If left unused, a fully charged battery will lose its charge over time.

Always try to keep the battery between 15°C and 25°C (59°F and 77°F). Extreme temperatures reduce the capacity and lifetime of the battery. A device with a hot or cold battery may not work temporarily. Battery performance is particularly limited in temperatures well below freezing.



Do not short-circuit the battery. Accidental short-circuiting can occur when a metallic object such as a coin, clip, or pen causes direct connection of the positive (+) and negative (-) terminals of the battery. (These look like metal strips on the battery.) This might happen, for example, when you carry a spare battery in your pocket or purse. Short-circuiting the terminals may damage the battery or the connecting object.

Do not dispose of batteries in a fire as they may explode. Batteries may also explode if damaged. Dispose of batteries according to local regulations. Please recycle when possible. Do not dispose as household waste.

Do not dismantle, cut, open, crush, bend, deform, puncture, or shred cells or batteries. In the event of a battery leak, do not allow the liquid to come in contact with the skin or eyes. In the event of such a leak, flush your skin or eyes immediately with water, or seek medical help.

Do not modify, remanufacture, attempt to insert foreign objects into the battery, or immerse or expose it to water or other liquids.

Improper battery use may result in a fire, explosion, or other hazard. If the device or battery is dropped, especially on a hard surface, and you believe the battery has been damaged, take it to a service centre for inspection before continuing to use it.

Use the battery only for its intended purpose. Never use any charger or battery that is damaged. Keep your battery out of the reach of small children.

Nokia battery authentication guidelines

Always use original Nokia batteries for your safety. To check that you are getting an original Nokia battery, purchase it from a Nokia authorised service centre or dealer, and inspect the hologram label using the following steps:

Successful completion of the steps is not a total assurance of the authenticity of the battery. If you have any reason to believe that your battery is not an authentic, original Nokia battery, you should refrain from using it, and take it to the nearest Nokia authorised service centre or dealer for assistance. If authenticity cannot be verified, return the battery to the place of purchase.

Authenticate hologram

- 1 When you look at the hologram on the label, you should see the Nokia connecting hands symbol from one angle and the Nokia Original Enhancements logo when looking from another angle.



- 2 When you angle the hologram left, right, down and up, you should see 1, 2, 3 and 4 dots on each side respectively.

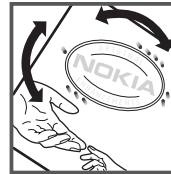

What if your battery is not authentic?

If you cannot confirm that your Nokia battery with the hologram on the label is an authentic Nokia battery, please do not use the battery. Take it to the nearest Nokia authorised service centre or dealer for assistance. The use of a battery that is not approved by Nokia may be dangerous and may result in poor performance and damage to your device and its accessories. It may also invalidate any approval or warranty applying to the device.

For additional information, refer to the warranty and reference leaflet included with your Nokia device.

Care and maintenance

Your device is a product of superior design and craftsmanship and should be treated with care. The following suggestions will help you protect your warranty coverage.

- Use a soft, clean, dry cloth to clean any lenses, such as camera, proximity sensor, and light sensor lenses.
- Do not use or store the device in dusty, dirty areas. Its moving parts and electronic components can be damaged.
- Do not store the device in hot areas. High temperatures can shorten the life of electronic devices, damage batteries, and warp or melt certain plastics.



44 Additional safety information

- Do not store the device in cold areas. When the device returns to its normal temperature, moisture can form inside the device and damage electronic circuit boards.
- Do not attempt to open the device other than as instructed in this guide.
- Do not drop, knock, or shake the device. Rough handling can break internal circuit boards and fine mechanics.
- Do not use harsh chemicals, cleaning solvents, or strong detergents to clean the device.
- Do not paint the device. Paint can clog the moving parts and prevent proper operation.
- Use only the supplied or an approved replacement antenna. Unauthorised antennas, modifications, or attachments could damage the device and may violate regulations governing radio devices.
- Use chargers indoors.
- Always create a backup of data you want to keep, such as contacts and calendar notes.
- To reset the device from time to time for optimum performance, power off the device and remove the battery.

These suggestions apply equally to your device, battery, charger, or any accessory. If any device is not working properly, take it to the nearest authorised service facility for service.

Recycle

Always return your used electronic products, batteries, and packaging materials to a dedicated collection point. This way you help prevent uncontrolled waste disposal and promote the recycling of materials. More detailed information is available from the product retailer, local waste authorities, national producer responsibility organisations, or your local Nokia representative. Check how to recycle your Nokia products at www.nokia.com/werecycle, or if browsing on a mobile device, www.nokia.mobi/werecycle.

Additional safety information

Note: The surface of this device does not contain nickel in the platings. The surface of this device contains stainless steel.

Magnets and magnetic fields

Keep your device away from magnets or magnetic fields.

Small children

Your device and its accessories may contain small parts. Keep them out of the reach of small children.

Operating environment

This device meets RF exposure guidelines when used either in the normal use position against the ear or when positioned at least 1.5 centimetres (5/8 inch) away from the body. When a carry case, belt clip, or holder is used for body-worn

operation, it should not contain metal and should position the device the above-stated distance from your body.

To transmit data files or messages, this device requires a quality connection to the network. In some cases, transmission of data files or messages may be delayed until such a connection is available. Ensure the above separation distance instructions are followed until the transmission is completed.

Medical devices

Operation of any radio transmitting equipment, including wireless phones, may interfere with the functionality of inadequately protected medical devices. Consult a physician or the manufacturer of the medical device to determine if they are adequately shielded from external RF energy or if you have any questions. Switch off your device in health care facilities when any regulations posted in these areas instruct you to do so. Hospitals or health care facilities may be using equipment that could be sensitive to external RF energy.

Implanted medical devices

Manufacturers of medical devices recommend that a minimum separation of 15.3 centimetres (6 inches) should be maintained between a wireless device and an implanted medical device, such as a pacemaker or implanted cardioverter defibrillator, to avoid potential interference with the medical device. Persons who have such devices should:

- Always keep the wireless device more than 15.3 centimetres (6 inches) from the medical device when the wireless device is turned on.
- Not carry the wireless device in a breast pocket.
- Hold the wireless device to the ear opposite the medical device to minimise the potential for interference.
- Turn the wireless device off immediately if there is any reason to suspect that interference is taking place.
- Read and follow the directions from the manufacturer of their implanted medical device.

If you have any questions about using your wireless device with an implanted medical device, consult your health care provider.

Hearing aids

Some digital wireless devices may interfere with some hearing aids. If interference occurs, consult your service provider.

Vehicles

RF signals may affect improperly installed or inadequately shielded electronic systems in motor vehicles such as electronic fuel injection systems, electronic antiskid (antilock) braking systems, electronic speed control systems, and air bag systems. For more information, check with the manufacturer, or its representative, of your vehicle or any equipment that has been added.



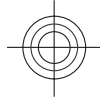

Additional safety information 45

Only qualified personnel should service the device or install the device in a vehicle. Faulty installation or service may be dangerous and may invalidate any warranty that may apply to the device. Check regularly that all wireless device equipment in your vehicle is mounted and operating properly. Do not store or carry flammable liquids, gases, or explosive materials in the same compartment as the device, its parts, or accessories. For vehicles equipped with an air bag, remember that air bags inflate with great force. Do not place objects, including installed or portable wireless equipment in the area over the air bag or in the air bag deployment area. If in-vehicle wireless equipment is improperly installed and the air bag inflates, serious injury could result.

Using your device while flying in aircraft is prohibited. Switch off your device before boarding an aircraft. The use of wireless teledevices in an aircraft may be dangerous to the operation of the aircraft, disrupt the wireless telephone network, and may be illegal.

Potentially explosive environments

Switch off your device when in any area with a potentially explosive atmosphere, and obey all signs and instructions. Potentially explosive atmospheres include areas where you would normally be advised to turn off your vehicle engine. Sparks in such areas could cause an explosion or fire resulting in bodily injury or even death. Switch off the device at refuelling points such as near gas pumps at service stations. Observe restrictions on the use of radio equipment in fuel depots, storage, and distribution areas; chemical plants; or where blasting operations are in progress. Areas with a potentially explosive atmosphere are often, but not always, clearly marked. They include below deck on boats, chemical transfer or storage facilities and areas where the air contains chemicals or particles such as grain, dust, or metal powders. You should check with the manufacturers of vehicles using liquefied petroleum gas (such as propane or butane) to determine if this device can be safely used in their vicinity.

Emergency calls

Important: This device operates using radio signals, wireless networks, landline networks, and user-programmed functions. If your device supports voice calls over the internet (internet calls), activate both the internet calls and the cellular phone. The device will attempt to make emergency calls over both the cellular networks and through your internet call provider if both are activated. Connections in all conditions cannot be guaranteed. You should never rely solely on any wireless device for essential communications like medical emergencies.

To make an emergency call:

- 1 If the device is not on, switch it on. Check for adequate signal strength. Depending on your device, you may also need to complete the following:
 - Insert a SIM card if your device uses one.

- Remove certain call restrictions you have activated in your device.
 - Change your profile from offline or flight profile mode to an active profile.
- 2 Press the end key as many times as needed to clear the display and ready the device for calls.
 - 3 Enter the official emergency number for your present location. Emergency numbers vary by location.
 - 4 Press the call key.

When making an emergency call, give all the necessary information as accurately as possible. Your wireless device may be the only means of communication at the scene of an accident. Do not end the call until given permission to do so.

Certification information (SAR)

This mobile device meets guidelines for exposure to radio waves.

Your mobile device is a radio transmitter and receiver. It is designed not to exceed the limits for exposure to radio waves recommended by international guidelines. These guidelines were developed by the independent scientific organisation ICNIRP and include safety margins designed to assure the protection of all persons, regardless of age and health.

The exposure guidelines for mobile devices employ a unit of measurement known as the Specific Absorption Rate or SAR. The SAR limit stated in the ICNIRP guidelines is 2.0 watts/kilogram (W/kg) averaged over 10 grams of tissue. Tests for SAR are conducted using standard operating positions with the device transmitting at its highest certified power level in all tested frequency bands. The actual SAR level of an operating device can be below the maximum value because the device is designed to use only the power required to reach the network. That amount changes depending on a number of factors such as how close you are to a network base station. The highest SAR value under the ICNIRP guidelines for use of the device at the ear is 0.48 W/kg.

Use of device accessories may result in different SAR values. SAR values may vary depending on national reporting and testing requirements and the network band. Additional SAR information may be provided under product information at www.nokia.com.

Your mobile device is also designed to meet the requirements for exposure to radio waves established by the Federal Communications Commission (USA) and Industry Canada. These requirements set a SAR limit of 1.6 W/kg averaged over one gram of tissue. The highest SAR value reported under this standard during product certification for use at the ear is 0.40 W/kg and when properly worn on the body is 0.41 W/kg.

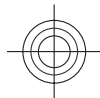

46 Index

Index	
A	
access codes	11
anykey answer	23
applications	33
B	
barring password	11
battery	6, 8
battery charge status	12
browser	32
business cards	37
C	
cache memory	33
calculator	38
call divert	23
call log	22
call waiting	23
caller id	23
calls	21
camera	27, 28
capture an image	27
configuration	20
contacts	
— memory	36
cookies	33
D	
data cable	19
dialling shortcuts	17, 22
digital rights	42
display	12, 17
downloads	40
E	
e-mail	26
equaliser	31
F	
factory settings	41
flash messages	25
flight profile	14
flight query	15
font size	17
G	
games	33
GPS	35
H	
handsfree	22
headset	9
help text	15
home screen	12, 17
I	
IM	25
image	27
in-call timer	23
indicators	13
info messages	20
instant messaging	25
internet	32
K	
keyguard	15
keypad lock	14
keys	6
L	
language	15
loudspeaker	22
M	
Maps	34
media player	29
memory card	7, 28
message centre number	24
message sending	25
microSD card	7
My Nokia	39
N	
navigation	13
Nokia support information	39

notes	38	status indicators	12
number mode	23	stereo widening	32
O		stopwatch	39
offline mode	14	strap	10
online sharing	32	support resources	39
operator menu	20	T	
P		text modes	23
PC Suite	38	themes	16
phone software updates	15	tones	17
PictBridge	19	torch	14
picture	27	traditional text input	23
PIN	11	U	
power saver	17	updates	
power saving	12	— device software	40
predictive text input	23	UPIN	11
print images	28	USB data cable	19
profiles	16	V	
PUK	11	video clips	27
R		voice clarity	23
radio	30	voice commands	17
recorder	31	voice dialling	22
redial	23	voice recognition	17
S		voice recorder	31
screen saver	17	W	
scrolling	13	wallpaper	17
security code	11	web	32
security module	11	write text	23
service commands	20		
sharing	32		
shortcuts	13, 17		
signal strength	12		
SIM			
— services	20		
SIM card	6, 14		
SIM messages	20		
sleep mode	17		
software update	40		
software updates	40		
speed dialling	17, 22, 23		
start up tone	15		

DECLARATION OF CONFORMITY

CE0434

Hereby, NOKIA CORPORATION declares that this RM-518 product is in compliance with the essential requirements and other relevant provisions of Directive 1999/5/EC. A copy of the Declaration of Conformity can be found at www.nokia.com/phones/declaration_of_conformity/.

© 2009 Nokia. All rights reserved.

Nokia, Nokia Connecting People and Navi are trademarks or registered trademarks of Nokia Corporation. Nokia tune is a sound mark of Nokia Corporation. Other product and company names mentioned herein may be trademarks or tradenames of their respective owners.

Portions of the Nokia Maps software are ©1996-2008 The FreeType Project. All rights reserved.

Reproduction, transfer, distribution, or storage of part or all of the contents in this document in any form without the prior written permission of Nokia is prohibited.



Includes RSA BSAFE cryptographic or security protocol software from RSA Security.



Java and all Java-based marks are trademarks or registered trademarks of Sun Microsystems, Inc.

This product is licensed under the MPEG-4 Visual Patent Portfolio License (i) for personal and noncommercial use in connection with information which has been encoded in compliance with the MPEG-4 Visual Standard by a consumer engaged in a personal and noncommercial activity and (ii) for use in connection with MPEG-4 video provided by a licensed video provider. No license is granted or shall be implied for any other use. Additional information, including that related to promotional, internal, and commercial uses, may be obtained from MPEG LA, LLC. See <http://www.mpegla.com>

Nokia operates a policy of ongoing development. Nokia reserves the right to make changes and improvements to any of the products described in this document without prior notice.

TO THE MAXIMUM EXTENT PERMITTED BY APPLICABLE LAW, UNDER NO CIRCUMSTANCES SHALL NOKIA OR ANY OF ITS LICENSORS BE RESPONSIBLE FOR ANY LOSS OF DATA OR INCOME OR ANY SPECIAL, INCIDENTAL, CONSEQUENTIAL OR INDIRECT DAMAGES HOWSOEVER CAUSED.

THE CONTENTS OF THIS DOCUMENT ARE PROVIDED "AS IS". EXCEPT AS REQUIRED BY APPLICABLE LAW, NO WARRANTIES OF ANY KIND, EITHER EXPRESS OR IMPLIED, INCLUDING, BUT NOT LIMITED TO, THE IMPLIED WARRANTIES OF MERCHANTABILITY AND FITNESS FOR A PARTICULAR PURPOSE, ARE MADE IN RELATION TO THE ACCURACY, RELIABILITY OR CONTENTS OF THIS DOCUMENT. NOKIA RESERVES THE RIGHT TO REVISE THIS DOCUMENT OR WITHDRAW IT AT ANY TIME WITHOUT PRIOR NOTICE.

The availability of particular products and applications and services for these products may vary by region. Please check with your Nokia dealer for details, and availability of language options.

Export controls

This device may contain commodities, technology or software subject to export laws and regulations from the US and other countries. Diversion contrary to law is prohibited.

FCC/INDUSTRY CANADA NOTICE

Your device may cause TV or radio interference (for example, when using a telephone in close proximity to receiving equipment). The FCC or Industry Canada can require you to stop using your telephone if such interference cannot be eliminated. If you require assistance, contact your local service facility. This device complies with part 15 of the FCC rules. Operation is subject to the following two conditions: (1) This device may not cause harmful interference, and (2) this device must accept any interference received, including interference that may cause undesired operation. Any changes or modifications not expressly approved by Nokia could void the user's authority to operate this equipment.

Model number: 3720

5555555/Issue 1 EN