

## Nokia 6822 User Guide

---



LEGAL INFORMATION

## CE 168

We, NOKIA CORPORATION declare under our sole responsibility that the product RM-68 is in conformity with the provisions of the following Council Directive: 1999/5/EC.  
A copy of the Declaration of Conformity can be found at [http://www.nokia.com/phones/declaration\\_of\\_conformity/](http://www.nokia.com/phones/declaration_of_conformity/).

PART NO. 9236281, ISSUE NO. 1  
Copyright ©2004 Nokia. All rights reserved.

Reproduction, transfer, distribution or storage of part or all of the contents in this document in any form without the prior written permission of Nokia is prohibited.

Nokia, Nokia Connecting People, Nokia 6822b, Pop-Port, and the Nokia Original Enhancements logos are trademarks or registered trademarks of Nokia Corporation. Other company and product names mentioned herein may be trademarks or trade names of their respective owners.

Nokia tune is a sound mark of Nokia Corporation.

Printed in Canada 02/2005

US Patent No 5818437 and other pending patents. T9 text input software Copyright ©1999-2004. Tegic Communications, Inc. All rights reserved.



Includes RSA BSAFE cryptographic or security protocol software from RSA Security.



Java is a trademark of Sun Microsystems, Inc.



The information contained in this user guide was written for the Nokia 6822b product. Nokia operates a policy of ongoing development. Nokia reserves the right to make changes to any of the products described in this document without prior notice.

UNDER NO CIRCUMSTANCES SHALL NOKIA BE RESPONSIBLE FOR ANY LOSS OF DATA OR INCOME OR ANY SPECIAL, INCIDENTAL, AND CONSEQUENTIAL OR INDIRECT DAMAGES HOWSOEVER CAUSED.

THE CONTENTS OF THIS DOCUMENT ARE PROVIDED "AS IS." EXCEPT AS REQUIRED BY APPLICABLE LAW, NO WARRANTIES OF ANY KIND, EITHER EXPRESS OR IMPLIED, INCLUDING, BUT NOT LIMITED TO, THE IMPLIED WARRANTIES OF MERCHANTABILITY AND FITNESS FOR A PARTICULAR PURPOSE, ARE MADE IN RELATION TO THE ACCURACY AND RELIABILITY OR CONTENTS OF THIS DOCUMENT. NOKIA RESERVES THE RIGHT TO REVISE THIS DOCUMENT OR WITHDRAW IT AT ANY TIME WITHOUT PRIOR NOTICE.

Export Controls

This device may contain commodities, technology or software subject to export laws and regulations from the US and other countries. Diversion contrary to law is prohibited.

FCC/Industry Canada Notice

Your phone may cause TV or radio interference (for example, when using a telephone in close proximity to receiving equipment). The FCC or Industry Canada can require you to stop using your telephone if such interference cannot be eliminated. If you require assistance, contact your local service facility. This device complies with part 15 of the FCC rules. Operation is subject to the condition that this device does not cause harmful interference.

Manufactured or sold under one or more of the following US Patents. Pending patent numbers are shown with an asterisk (\*).

## Quick guide

---

### ■ Actions

#### Press

Press a key briefly and release it.

#### Press and hold

Press a key, hold it for two to three seconds, and release it.

#### Make a call

Enter a phone number, and press **Call**.

#### Answer a call

Press **Call**, or select *Answer*.

#### Answer call during call

Press **Call**.

#### End a call

Press **End** or select *Options* > *End call*.

#### Decline a call

Press **End** to send the call to voice mail.

#### Mute a call

Select *Options* > *Mute* during a call.

#### Redial

Press **Call** twice.

#### Adjust call volume

Move the **Five-way joystick** to the left or right during a call.

#### Use in-call menu

Select *Options* during a call.

#### Save name and number

Enter a number. Select *Save*. Enter a name. Select *OK*.

#### Use 1-touch dialing

Press and hold a key (**2-8**). You must assign a key to a number in the phone book.

## Quick guide

### Look up a name

Select *Contacts* > *Find*.

### Check voice mail

Press and hold the **1** key (contact your service provider for details).

### Write text messages

Select *Menu* > *Messages* > *Text messages* > *Create message* or move the Five-way joystick to the right. Write the message.

### Send text messages

In the message entry screen, select *Send*. Enter the recipient's phone number or search for it in contacts, and select *OK*. The message service is dependent on the service provider.

### Read new message

If *Messages received* appears on the display, select *Show*; then select the message you want to read.

### Reply to a message

Select *Options* > *Reply*. Write a reply. Select *Options* > *Send*.

Contents

## Contents

---

1. Phone at a glance.....	13
2. SIM card and battery.....	14
3. About your phone.....	17
4. Basic operations .....	24
5. Phone menu .....	26
6. Phone security.....	28
7. Writing text .....	30
8. Messages.....	34
9. Instant messages.....	45
10. Call log.....	51
11. Contacts.....	52
12. Settings.....	60
13. Gallery .....	66
14. Camera .....	67
15. Organizer.....	69
16. Applications.....	73
17. Services.....	78
18. Connectivity.....	85
19. PC connectivity.....	90
20. Reference information .....	92

## For your safety

---

Read these simple guidelines. Not following them may be dangerous or illegal. Read the complete user guide for further information.



### SWITCH ON SAFELY

Do not switch the phone on when wireless phone use is prohibited or when it may cause interference or danger.



### ROAD SAFETY COMES FIRST

Obey all local laws. Always keep your hands free to operate the vehicle while driving. Your first consideration while driving should be road safety.



### INTERFERENCE

All wireless phones may be susceptible to interference, which could affect performance.



### SWITCH OFF IN HOSPITALS

Follow any restrictions. Switch the phone off near medical equipment.



### SWITCH OFF IN AIRCRAFT

Follow any restrictions. Wireless devices can cause interference in aircraft.



### SWITCH OFF WHEN REFUELING

Don't use the phone at a refueling point. Don't use near fuel or chemicals.



### SWITCH OFF NEAR BLASTING

Follow any restrictions. Don't use the phone where blasting is in progress.



### USE SENSIBLY

Use only in the normal position as explained in the product documentation. Don't touch the antenna unnecessarily.



### QUALIFIED SERVICE

Only qualified personnel may install or repair this product.



### ENHANCEMENTS AND BATTERIES

Use only approved enhancements and batteries. Do not connect incompatible products.

## For your safety



### WATER-RESISTANCE

Your phone is not water-resistant. Keep it dry.



### BACKUP COPIES

Remember to make backup copies or keep a written record of all important information stored in your phone.



### CONNECTING TO OTHER DEVICES

When connecting to any other device, read its user guide for detailed safety instructions. Do not connect incompatible products.



### EMERGENCY CALLS

Ensure the phone is switched on and in service. Press **End** as many times as needed to clear the display and return to the start screen. Enter the emergency number, then press **Call**. Give your location. Do not end the call until given permission to do so.

## ■ About your device

The wireless device described in this guide comes in two models. The Nokia 6822b phone is approved for use on the GSM 850, 1800, and GSM 1900 networks. See "Phone information" on page 12, to identify your specific phone model. Contact your service provider for more information about networks.

When using the features in this device, obey all laws and respect privacy and legitimate rights of others.



**Warning:** To use any features in this device, other than the alarm clock, the phone must be switched on. Do not switch the device on when wireless phone use may cause interference or danger.



**Note:** Your device and its enhancements may contain small parts. Keep them out of the reach of small children.

## ■ Network Services

To use the phone you must have service from a wireless service provider. Many of the features in this device depend on features in the wireless network to function. These Network Services may not be available on all networks or you may have to make specific arrangements with your service provider before you can utilize Network Services. Your service provider may need to give you additional instructions for their use and explain what charges will apply. Some networks may have limitations that affect how you can use Network Services. For



## For your safety

instance, some networks may not support all language-dependent characters and services.

Your service provider may have requested that certain features be disabled or not activated in your device. If so, they will not appear on your device menu. Contact your service provider for more information.

This wireless device is a 3GPP GSM Release 99 terminal supporting GPRS service, and is designed to support Release 4 GPRS networks. However, there may be some compatibility issues when used in some Release 97 GPRS networks. For more information contact your service provider.

This device supports WAP 2.0 protocols [HTTP and SSL] that run TCP/IP protocols. Some features of this device require network support for these technologies.

### ■ Shared memory

The phone has three different memories. Contacts, text messages, SMS e-mail, voice tags, calendar, and notes may share the first memory. The second shared memory is used by multimedia messages, files stored in *Gallery*, and configuration settings. The third shared memory is used by the e-mail application and Java games and applications. Using one or more of these features may reduce the memory available for the remaining features sharing the same memory. For example, saving many *Gallery* items may use all of the available memory in the second memory. Your device may display a message that the memory is full when you try to use a shared memory feature. In this case, delete some of the information or entries stored in the corresponding shared memory before continuing.

W e l c o m e

## Welcome

---

Congratulations on your purchase of the Nokia 6822b mobile phone. Your phone provides many functions that are practical for daily use, such as a calendar, a clock, an alarm clock, and a built-in camera. The camera can be used for recording video clips and taking pictures that you can attach as wallpaper in the standby mode or as thumbnail pictures in *Contacts*. For more information, see "Camera" on page 67 .

Other features on your phone are:

- Multimedia messaging, see "Multimedia messages (MMS) (network service)" on page 36 .
- Instant messages, see "Instant messages" on page 45 .
- Presence-enhanced contacts, see "My presence" on page 54 .
- E-mail application, see "E-mail (network service)" on page 39 .
- EDGE (enhanced data rates for GSM evolution), see "GPRS and EGPRS" on page 88 .
- J2ME™ Java 2 Micro Edition, see "Applications" on page 73 .
- XHTML browser, see "Services" on page 78 .
- Bluetooth connectivity, see "Set up a Bluetooth connection" on page 85 .

### ■ Access alternate formats

This user guide is available in alternate formats, contact Nokia at [www.nokiaaccessibility.com](http://www.nokiaaccessibility.com) or call 1-888-665-4228 for more information.

### ■ Register your phone

Make sure to register your phone at [www.warranty.nokiausa.com](http://www.warranty.nokiausa.com) or 1-888-NOKIA-2U (1-888-665-4228) so that we can serve your needs better if you should need to call the center or have your phone repaired.

### ■ Copyright protection

Copyright protections may prevent some images, ringing tones, and other content from being copied, modified, transferred, or forwarded.

## ■ Contact Nokia

If you ever need to call Nokia Customer Care or your service provider, you must provide specific information about your phone (see "Phone information" on page 12).

Whether you call about your phone or an enhancement, have the equipment with you when you call. If a Nokia representative asks a specific question about the enhancement, you will have it available for quick reference.

### Nokia support on the web

Check [www.nokia.com/support](http://www.nokia.com/support) or your local Nokia web site for the latest version of this user guide, additional information, downloads, and services related to your Nokia product.

### Contact Nokia

Please have your product with you when contacting either of the numbers below:

#### **Nokia Customer Care Center, USA**

Nokia Inc.

7725 Woodland Center Boulevard, Suite #150

Tampa, Florida 33614

Tel: 1-888-NOKIA-2U (1-888-665-4228)

Fax: 1-813-249-9619

TTY (hearing impaired only): 1-800-24-NOKIA

#### **Customer Care Center, Canada**

Nokia Products Ltd.

601 Westney Road South

Ajax, Ontario L1S 4N7

Tel: 1-888-22-NOKIA (1-888-226-6542)

Fax: 1-905-427-1070

W e l c o m e

### **Phone information**

Information about your phone is provided on the phone label on the back of the phone under the battery (see "Remove the back cover" on page 14 ). The label contains the model and serial numbers, as well as the following:

- Phone type (such as RM-68)
- Phone model (such as Nokia 6822b)
- International Mobile Equipment Identity (IMEI)
- FCC ID number

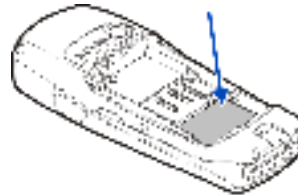

### **Contact your service provider**

In many cases, the service provider will make available descriptions of its services and instructions for using features, such as:

- Voice mail and voice privacy
- Call waiting, call forwarding, and caller ID
- Messaging
- News and information services
- Selected Internet services

Service providers may differ in their support of features. Before you sign up with a service provider, make sure that the service provider supports the features that you need.

## 1. Phone at a glance

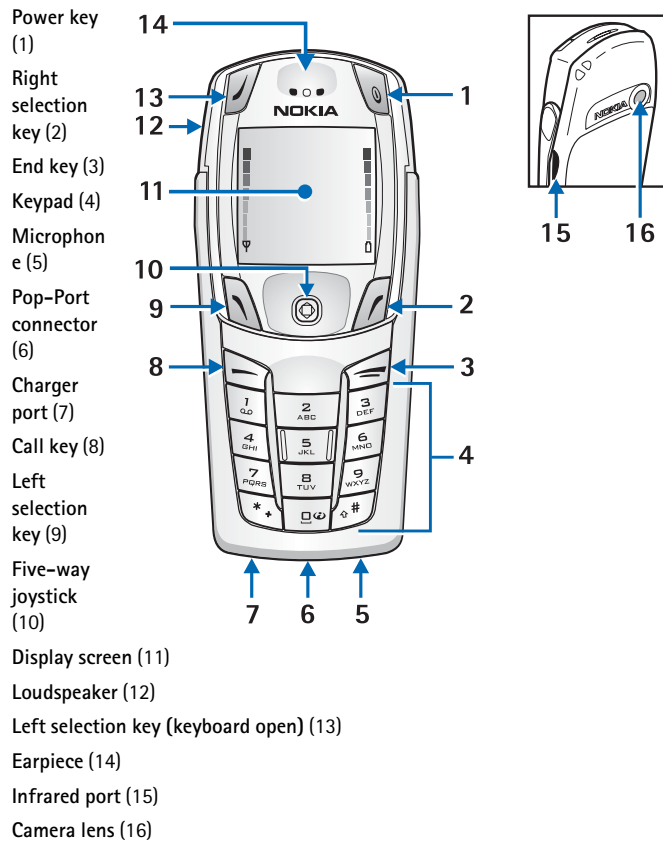

## 2. SIM card and battery

---

The SIM card and its contacts can easily be damaged by scratches or bending, so be careful when handling, inserting, or removing the card.

Your device and its enhancements may contain small parts. Keep them out of the reach of small children.

For availability and information on using SIM card services, contact your SIM card vendor. This may be the service provider or another vendor.

Always switch the device off and disconnect the charger before removing the battery.

### ■ Remove the back cover

Push the back cover release button toward the bottom of the phone (1) and at the same time, lift the back cover away from the phone (2).

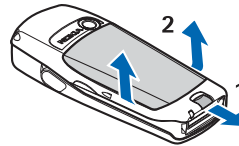

### ■ Insert the SIM card and battery

**Important:** Insert the battery exactly as shown in the diagram. The contacts on the battery must be aligned with the contacts on the phone for the phone to operate.

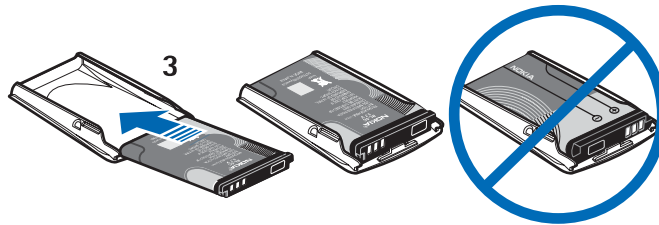

## SIM card and battery

To release the SIM card holder, slide the card holder to the right (4), and open it by lifting it up (5).

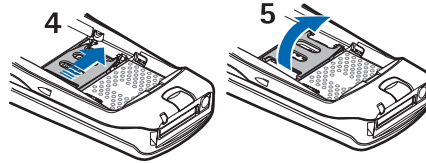

Insert the SIM card into the SIM card holder (6).

Make sure that the SIM card is properly inserted and that the golden contact area on the card is facing downward. Close the SIM card holder (7), and slide it back into place (8).

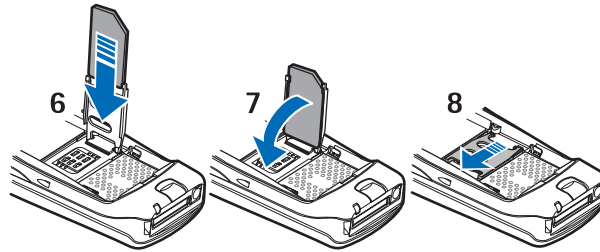

Direct the back cover toward the locking catches on the front cover (9), and slide the back cover until it locks into place (10).

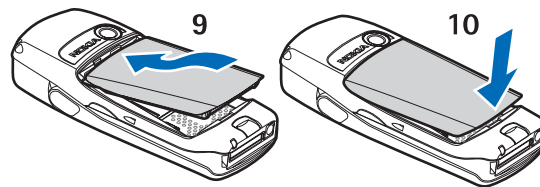

## SIM card and battery

### ■ Charge the battery



**Warning:** Use only batteries, chargers, and enhancements approved by Nokia for use with this particular model. The use of any other types may invalidate any approval or warranty, and may be dangerous.

Your phone is powered by a rechargeable battery. To charge the battery:

1. Plug the charger transformer into a standard ac outlet.
2. Insert the charger output plug into the round connector at the bottom end of the phone.

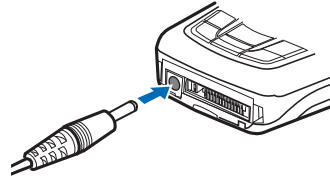

After a few seconds, the battery indicator in the display starts to scroll from bottom to top. If the battery is completely discharged, it may take a few minutes before the charging indicator appears on the display or any calls can be made.

You can use the phone while the charger is connected.

The BL-5C battery provides up to 3.5 hours of talk time and up to 14 days of standby time. Operation times are estimates and may vary depending on network conditions, charging, and phone use. Charging the battery with the ACP-12 charger takes approximately 1 hour and 30 minutes while the phone is in the standby mode.

For availability of approved enhancements, please check with your dealer. When you disconnect the power cord of any enhancement, grasp and pull the plug, not the cord.



### 3. About your phone

---

#### ■ In-phone help

Many features have brief descriptions (help text) which can be viewed on the display. To view the help text, scroll to a feature and wait for about 15 seconds. Select *More* to view all of the description (if necessary) or select *Back* to exit. For instructions on how to turn the help text feature on and off, see "Phone settings" on page 63 .

#### ■ Start screen (standby mode)

The start screen is home base and indicates that the phone is in the standby mode.

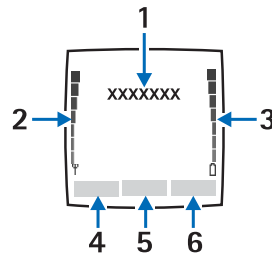

- (1) The name of your service provider may appear here.
- (2) *Audible signal bar*—A higher bar indicates a stronger network signal.
- (3) *Audible battery bar*—A higher bar indicates more power in the battery.
- (4) *Left selection key*—The *Left selection key* in the standby mode opens the *Go to* menu. For more information, see "Go to options" on page 61 .
- (5) *Menu*—Press the *Five-way joystick* to select the item displayed in the bottom center (middle selection area) of the display screen. In the standby mode, press the joystick to open the *Menu*.
- (6) *Right selection key*—The *Right selection key* in the standby mode opens either the *Contacts* menu (default), a service provider's home page, or a user-specified function. For more information, see "Personal shortcuts" on page 61 .

## About your phone

### ■ Antenna

Your device has an internal antenna. Hold the phone as shown with the antenna area pointing up.



**Note:** As with any other radio transmitting device, do not touch the antenna unnecessarily when the device is switched on. Contact with the antenna affects call quality and may cause the phone to operate at a higher power level than otherwise needed. Avoiding contact with the antenna area when operating the phone optimizes the antenna performance and the battery life.



### ■ Phone basics

Your phone can be used with the keyboard open or closed.

To open the keyboard, do the following:

1. Hold the phone with both hands, and open the keyboard as shown.

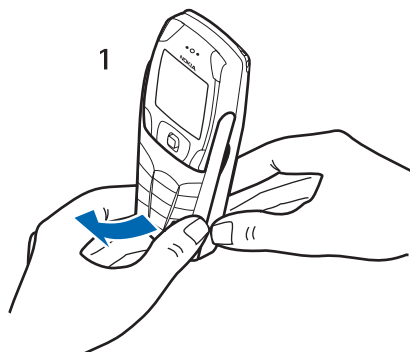

About your phone

2. Extend the keyboard until you hear it click into place.

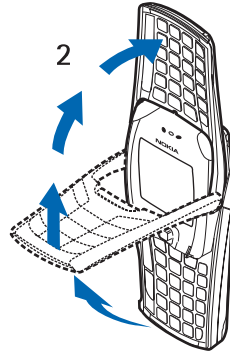

3. Turn the phone to a horizontal position and hold it as shown.

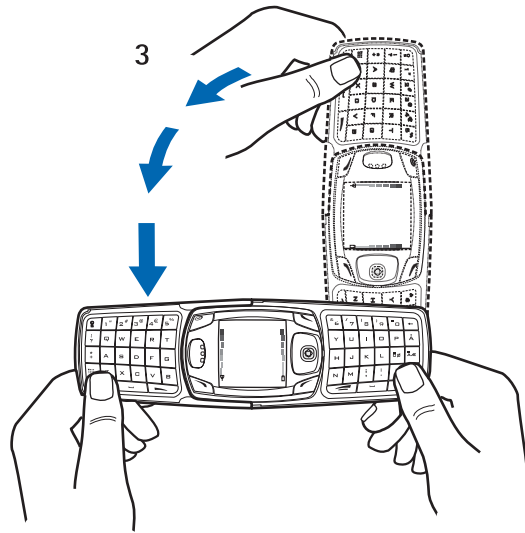

## About your phone

### ■ Key functions (keyboard closed)

**Power key (1)** switches the phone on and off. When the keypad is locked, it turns the phone display lights on for about 15 seconds.

**Selection key (2)** has no function when the keyboard is closed.

**Left selection key (3)** and **Right selection key (3)** provide a variety of functions depending on the display text above the keys.

**Five-way joystick (4)** moves in four directions and selects the active menu option when pressed. For details, see "The five-way joystick" on page 22 .

**Call key (5)** dials a phone number and answers a call. In the standby mode it accesses the list of most recently called numbers.

**End key (6)** ends an active call or exits from the current function.

**Keypad (7)** enters numbers and characters.

**Note:** Some phones may not display the mobile Internet symbol on the 0 key.

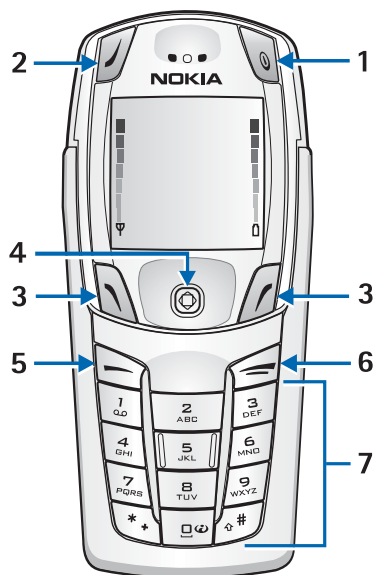

## ■ Key functions (keyboard open)

When the keyboard is opened, the display graphics rotate 90 degrees and the **Left** and **Right** selection keys change positions. The guiding text near the **Left** and **Right** selection keys does not change.

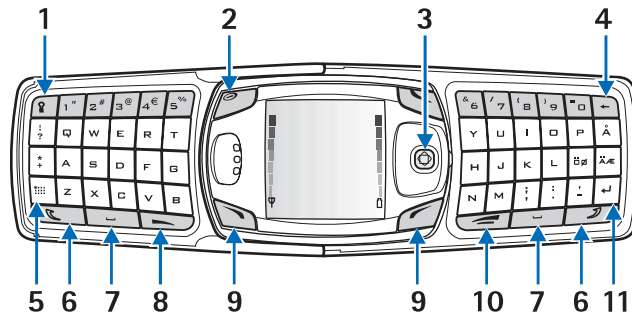

**Keyboard light key (1)** switches the keyboard light on or off.

**Power key (2)** switches the phone on and off.

**Five-way joystick (3)** moves in four directions and selects the displayed menu option when pressed.

**Backspace key (4)** deletes characters.

**Character key (5)** opens a set of characters and symbols during text writing.

**Shift keys (6)** enters upper case letters and symbols. You can press the Shift key first, then the desired key; or press both keys at the same time.

**Space bar keys (7)** enters a space.

**Call key (8)** dials a phone number and answers a call. In the standby mode it accesses the list of most recently called numbers.

**Left selection key (9) and Right selection key (9)** selects the menu option shown by the text displayed above the key.

**End key (10)** ends an active call or exits from a function.

**Enter key (11)** starts a new line when writing text.

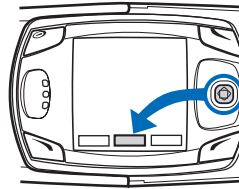

## About your phone

### ■ The five-way joystick

The Five-way joystick provides a variety of functions:

- Allows you to scroll through lists
- Moves the cursor up, down, right and left when writing text, using the calendar, and in some game applications
- Selects the active menu item when pressed briefly (or confirms a selection)
- Adjusts the volume when moved to the left (to decrease volume) or to the right (to increase volume) during a call
- Activates the camera when moved up in the standby mode
- Opens the text editing screen to write a text message when moved to the left in the standby mode
- Opens the calendar when moved to the right in the standby mode
- Opens the contacts list when moved down in the standby mode

### ■ Indicators and icons

The following icons may be displayed in the standby mode:

 – You have one or more text or picture messages. See "Text messages (SMS) (network service)" on page 34.

 – The phone has logged a missed call. See "Call log" on page 51.

 – Your phone is connected to the instant messaging service, and the availability status is online or offline, respectively. See "Instant messages" on page 45.

 – You have received one or several instant messages, and you are connected to the instant messages service. See "Instant messages" on page 45.

 – You have one or more multimedia messages. See "Text messages (SMS) (network service)" on page 34.

 – You have one or more voice messages. See "Voice messages" on page 41.

 – Your phone keypad is locked. See "Lock the keypad (keyguard)" on page 28.

 – Your phone is set to the *Silent* profile. See "Profiles" on page 60.



 – The alarm clock is set to *On*. See "Alarm clock" on page 69.

## About your phone

 – The GPRS connection mode *Always online* is selected and the GPRS services is available.

 – You have an incoming or outgoing call during a GPRS dialup connection. GPRS is suspended.

 – There is an active GPRS connection.



 – Forward all voice calls. All calls are forwarded to another number. If you have two phone lines, the indicator for line 1 is  and  for line 2.

 – If you have two phone lines, this indicates that you are on the second phone line. See "Call settings" on page 62.

 – Calls are limited to a closed group. See "Security settings" on page 64.

 – The timed profile is selected. See "Profiles" on page 60.

 – Integrated handsfree is active. See "Loudspeaker" on page 25.

, , or  – A headset, handsfree, or Nokia Loopset enhancement is connected to the phone.

 – Bluetooth connection indicator. See "Set up a Bluetooth connection" on page 85.

## 4. Basic operations

---

### ■ Switch the phone on or off

1. To switch your phone on or off, press and hold the power key as shown.

If the phone displays *Insert SIM card* or *SIM card not supported*, even though the SIM card is properly inserted, contact your service provider.

2. If the phone asks for a PIN code, enter the PIN code (displayed as \*\*\*\*), and select *OK*.
3. If the phone asks for a security code, enter the security code, and select *OK*.

See "Access codes" on page 28 for more information.



### ■ Set the time

Select *Menu* > *Settings* > *Time and date settings* > *Clock* > *Set the time*. Enter the time (in hh:mm format), and select *OK* > *am* or *pm*.

### ■ Make and answer calls

**Use the keypad**—Enter the phone number (including the area code), and press *Call*. To delete a character to the left of the cursor, select *Clear*. To end the call or to cancel the call attempt, press *End*.

**Use contacts**—At the start screen, move the **Five-way joystick** downward to view your contacts, scroll to the entry you want to call, and press *Call* to make the call.

**Redial the last number**—At the start screen, press *Call* twice.

**Make an international call**—Press \* twice to enter the international prefix [a plus (+) sign] in place of the international access code. Then enter the country code, the area code without a leading zero (if necessary), and the phone number.

**Answer or reject a call**—Press *Call* to answer the call, or press *End* to reject the call. If *Forward if busy* is activated to your voice mailbox, the call is forwarded to your voice mail. If not, the call is rejected.

If you select *Silence*, only the ringing tone is muted. You can then either answer or reject the incoming call.



Answer a call with the keypad locked—See "Lock the keypad (keyguard)" on page 28 .

1-touch dialing—See "1-touch dialing" on page 58 .

Call waiting—See "Call settings" on page 62 .

### ■ Adjust the earpiece volume

To increase the volume of a call, move the **Five-way joystick** to the right. To decrease the volume of a call, move the **Five-way joystick** to the left.

When adjusting the volume, a bar chart appears in the display indicating the volume level. See volume control information in "Call settings" on page 62 .

You can only adjust the earpiece volume during an active call.

### ■ Loudspeaker



**Warning:** Do not hold the device near your ear when the loudspeaker is in use, because the volume may be extremely loud.

You can use your phone as a loudspeaker during a call.

To activate the loudspeaker during a call, select *Loudspeaker*.

To deactivate the loudspeaker during a call, select *Normal*.

## 5. Phone menu

---

Phone features are accessed through the main menu of your phone. Use the menus and submenus to select or view items and customize phone features.



**Note:** Some service providers order the phones specially programmed for their network. Some features may not be shown on the menu.

In the standby mode, press the joystick to select *Menu*. The first menu item is displayed.

You can view the menu as a list or as a grid:

**List view**—List view is the default view for the main menu. Scroll up and down to view main menu selections one at a time.

**Grid view**—To switch between *List* and *Grid* view, see "Display settings" on page 62. In *Grid* view, scroll up, down, right, and left to navigate through the main menu icons.

In the *Grid* view, the icon for the selected menu is outlined, and the name of the menu appears at the top of the display.

As you scroll through the menus, the menu number appears in the upper right corner of the display. Below the menu number is a scroll bar with a tab.

The tab moves up or down as you scroll through the menus, providing a visual representation of your current position in the menu structure.

**Open a menu item**—Scroll to it, and select it.

**Open a submenu**—If the menu contains submenus, use the scroll keys to highlight the desired menu; then select it.

**Return to the previous menu**—Select *Back* to return to the previous menu or submenu.

**Return to the start screen**—Press End from any menu screen.

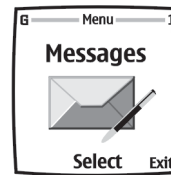

## ■ Operator menu

This menu lets you access a portal to services provided by your service provider. This menu is operator specific. The name and the icon depend on the operator. For more information, contact your service provider.

The operator can update this menu with a service message. For more information, refer to "Service inbox" on page 81 .

## ■ SIM services

In addition to the functions available on the phone, your SIM card may provide services that you can access in this menu item, which is shown only if it is supported by your SIM card. The name and contents of the menu depend on the SIM card.



For availability, rates, and information on using SIM services, contact your SIM card vendor, for example, the service provider or other vendor.

Depending on the operator, you can set the phone to show you the confirmation messages sent between your phone and the network when you are using the SIM services. Select *Menu > Settings > Phone settings > Confirm SIM service actions > Yes*.

Accessing these services may involve sending messages or making a phone call for which you may be charged.

## 6. Phone security

---

### ■ Lock the keypad (keyguard)

You can lock the keypad to prevent accidental key presses. To answer a call with keyguard on, press **Call**. During the call, all features function as normal. When you end or reject a call, the keypad automatically relocks.

- To lock the keypad, select *Menu* > #.
- To unlock the keypad, select *Unlock* > #.

When the keypad is locked, calls may be possible to the official emergency number programmed into your phone. Enter the emergency number, and press **Call**.

### ■ Automatic keyguard

You can set your phone to lock the keys automatically after a time you specify. See "Phone settings" on page 63 to activate this feature.

### ■ The security keyguard

The security keyguard locks the keypad of the phone with a security code. The keypad lock remains active, if you open the flip. Select *Menu* > *Settings* > *Phone settings* > *Security keyguard*.

Enter the security code. To set the security keyguard, select *On*.

To activate the security keyguard when the phone is closed, select *Menu* > # within 1.5 seconds.

To deactivate the keyguard when the flip is open, select *Unlock* > *OK*, and enter the security code. If the phone is closed, select *Unlock* > # within 1.5 seconds, and enter the security code. If you receive a *Bluetooth* connection request from another device while the security keyguard is activated, you have to deactivate the keyguard before you can accept the connection.

### ■ Access codes

The following access codes allow you to secure your phone from unauthorized use. To change access codes, see "Security settings" on page 64. Keep the new codes secret and in a safe place, separate from your phone.

## Phone security

**Security code**—This code, supplied with the phone, protects your phone against unauthorized use. The preset code is 12345.

**PIN code**—This code, supplied with the SIM card, protects the card against unauthorized use. Turn the **PIN code request** on so that the code is requested each time the phone is switched on. If you enter an incorrect PIN code three times in succession, the SIM card is blocked. You must enter the PUK code to unblock the SIM card and set a new PIN code.

**PIN2 code**—This code is supplied with some SIM cards and is required to access certain services, such as charging unit counters. If you enter an incorrect PIN2 code three times in succession, **PIN2 code blocked** appears in the display, and you are asked for the PUK2 code.

**PUK code** and **PUK2 code**—These unblocking codes may be supplied with the SIM card. For more information, contact your service provider.

**Restriction password**—This password is needed with **Call restrictions**. You can obtain the password from your service provider.

## 7. Writing text

---

You can enter text and numbers with the keypad open or closed.

### ■ Write with the keyboard open

When the keyboard is open, you can start to write a message in several ways.

- Select *Menu > Messages > Text messages > Create message*.
- Move the joystick to the left in standby mode.
- Press any of the letter keys in the standby mode to open *Notes*.

### Available functions

The following functions are available when writing text with the keyboard open:

- To insert a number, press a number key. (If you press a number key in the standby mode, it initiates a normal call procedure.)
- To switch between the lower and upper case, indicated by **Abc**, **ABC**, or **abc** on the top left of the display, or to insert symbols, press the **Shift** keys on the keyboard. You can either press a **Shift** key and the desired character consecutively; or press and hold a **Shift** key and the desired letter at the same time.
- To write in upper case only, press one of the **Shift** keys twice.
- To delete characters from the display, press the **Backspace** key, or select **Clear**. Press the **Backspace** key briefly to clear one character at a time. Use a longer keypress to delete characters more quickly.
- To add a space, press one of the **Space** keys at the bottom of the keyboard.
- To create a line break, press the **Enter** key.



### Typing accented characters

The characters available depend on the language selected in the *Phone language* menu. To type accented characters or symbols that are not printed on the keyboard, do one of the following:

- To access a set of punctuation marks, accented characters, and symbols, press the **Character** key. Scroll through the character set with the joystick, and select *Insert* to enter the selected character.
- To type an accented character that is not included in the list of special characters under the **Character** key, press and hold the **Character** key, and simultaneously press **A** repeatedly until the desired accented variant of **A** appears on the display.

### ■ Write with the keyboard closed

You can use two methods for entering text and numbers with the keyboard closed:

- **Standard mode** (  ) is the only way to enter names into *Contacts* and to rename caller groups.
- **Predictive text input** (  ) is a quick and easy method for writing messages.

Press the **#** key to switch predictive text on or off and to use predictive text in various modes.

### ■ Standard mode

Press a key once to insert the first letter on the key, twice for the second letter, etc. If you pause briefly, the last letter in the display is accepted, and your phone awaits the next entry.

Select *Clear* to backspace the cursor and delete a character.



Select and hold *Clear* to backspace continuously and delete characters.

Press **0** to enter a space and accept a completed word.

Press **1** to enter a period (.).

Press **\*** to display special characters. See "Enter punctuation and special characters" on page 33 .

Press and hold the **#** key to switch between text and numeric entry. The icon  is displayed at the top of the screen when the phone is in numeric entry mode.

Depending on which capitalization mode you have selected, one of the icons , , or  is displayed when the phone is in text entry mode.

## Writing text

### ■ Predictive text

Predictive text input allows you to write messages quickly using your keypad and the built-in phone dictionary. It is much faster than using the standard mode multi-tap method. You can use predictive text to write a message and create a calendar note.

To activate predictive text at any text entry screen, select *Options > Predictive text*. Select a language.

#### How to use predictive text

- For each letter of the word that you want to spell, press the corresponding key on your keypad only once, even if the letter you want is not the first letter on the key. The phone guesses the word you are trying to spell.
- If a displayed word is not correct, press \* to see other matches. To move forward through a list of matches, press \* repeatedly. To return to the previous word in the list of matches, select *Prev.*
- Press *O* to accept the word, enter a space, and begin writing the next word.
- If *?* appears after a word, select *Spell* to add the word to the dictionary. See "Add new words to the dictionary" on page 32 .
- Press *!* to insert a period into your message.
- Press and hold the \* to display special characters. See "Enter punctuation and special characters" on page 33 .

#### Compound words

Enter the first part of the word and confirm it, by moving the joystick to the right. Enter the last part of the word and confirm it, by moving the joystick to the right.

#### Add new words to the dictionary

If you encounter a word that predictive text does not recognize, a question mark (?) follows the word and *Spell* appears in the lower left of the display.

Select *Spell*, enter your new word using the keypad, and select *Save*. The word is added to the dictionary and to the message that you are writing.

Keep these factors in mind when adding words:



## Writing text

- New words that you accept by selecting *Save*, the *0* key, or deleting the space between two words are saved to the dictionary.
- Depending on the language and the length of the words, you may be able to add hundreds of words to the dictionary.
- When the dictionary is full, the most recent addition replaces the first.

### ■ Enter punctuation and special characters

While at any text entry screen, press the *\** key to display special characters (press and hold the *\** key if predictive text is on).

Press the *\** key twice to display the *Graphical smileys* menu.

Scroll through the list of special characters by using the *Five-way joystick*. Once a character is highlighted, press the *Five-way joystick* to insert the character into your message.

## 8. Messages



The message services can only be used if they are supported by your network or your service provider.

To select the font size for reading and writing messages, select [Menu > Messages > Message settings > Other settings > Font size](#).

 **Note:** When sending messages, your phone may display *Message sent*. This is an indication that the message has been sent by your device to the message center number programmed into your device. This is not an indication that the message has been received at the intended destination. For more details about messaging services, check with your service provider.

### ■ Text messages (SMS) (network service)

Using the SMS (short message service), your phone can send and receive multipart messages, which consist of several ordinary text messages. Invoicing may be based on the number of ordinary messages that are required for a multipart message.

Before you can send a message, you need to save some message settings. See "Settings for text and e-mail messages" on page 42.

You can also send and receive text messages that contain pictures. A picture message can be a multipart message.

 **Note:** Only devices that offer picture message features can receive and display picture messages.

### Write and send messages

Your device can send text messages beyond the normal 160-character limit. If your message exceeds 160 characters, it is sent as a series of two or more messages. The number of available characters and the current part number of a multipart message are shown on the top right of the display, (for example 120/2). Using special (Unicode) characters such as è, â, á, ì takes up more space.

1. Select [Menu > Messages > Text messages > Create message](#).
2. Enter a message. See "Writing text" on page 30. To insert text templates or a picture into the message, see "Templates" on page 36.

3. Select *Send*, or press **Call** to send the message.

The messages that you send are saved in the *Sent items* folder if the setting *Save sent messages* is set to *Yes*. See "Settings for text and e-mail messages" on page 42 . Text messages are indicated with .

4. Enter the recipient's phone number, or search for the phone number in *Contacts*.
5. Select *OK* to send the message.

### Options for sending a message



After you have write a message, select *Options* > *Sending options* and one of the following:

*Send to many*—Send the message to several recipients.

*Send to list*—Send the message to members of a distribution list.

*Sending profile*—Use a predefined message profile to send the message. To define a message profile, see "Settings for text and e-mail messages" on page 42 .

### Read and reply to message or e-mail

When you receive a message or an SMS e-mail, the indicator  and the number of new messages followed by *Messages received* is shown. A blinking  indicates that the message memory is full. Before you can receive new messages, delete some of your old messages in the *Inbox* folder. If more than one message is received, select the one that you want to read. An unread text message or SMS e-mail is indicated by .

1. Select *Show* to view the new message or select *Exit* to view it later.

When you select *Options* while reading a message, some of the following options may be available: *Delete*, *Forward*, or *Edit* the message as a text message or an SMS e-mail; *Rename* the message you are reading or move it to another folder; *Copy to calendar* to copy text at the beginning of the message to your phone calendar as a reminder note for the current day; *Message details* to view, if available, the sender's name and phone number, the message center used, and the date and time of receipt; *Use detail* to extract numbers, e-mail addresses, and Web site addresses from the current message.

## Messages

When reading a picture message, select [Save picture](#) to save the picture in the [Templates](#) folder.

2. Select [Reply](#) and select the message type to reply to a message.



When replying to an SMS e-mail, confirm or edit the e-mail address and subject before you create your reply message.

3. To send the reply message to the displayed number or e-mail address, select [Send](#) > [OK](#).

## Inbox and sent items folders

The phone saves incoming text and multimedia messages in the [Inbox](#) folder. Sent text messages are saved in the [Sent items](#) folder.

## Templates

Your phone includes text templates, indicated by , and picture templates, indicated by . To access the template list, select [Menu](#) > [Messages](#) > [Text messages](#) > [Templates](#).

## Saved items folder and My folders

To organize your messages, you can move some of them to the [Saved items](#) folder or add new folders for your messages. While reading a message, select [Options](#) > [Move](#), scroll to the new folder, and press [Select](#).

To add or delete a folder, select [Menu](#) > [Messages](#) > [Saved items](#) > [Text messages](#) > [My folders](#).

To add a folder if you have not saved any folder, select [Add](#).

To add a folder if you have already added and saved a folder, select [Options](#) > [Add folder](#).

To delete a folder, scroll to the folder that you want to delete, and select [Options](#) > [Delete folder](#).

## ■ **Multimedia messages (MMS) (network service)**



**Note:** Only devices that offer compatible multimedia message features can receive and display multimedia messages. Exercise caution when opening messages. Messages may contain malicious software or otherwise be harmful to your device or PC.

A multimedia message can contain text, sound, and a picture or a video clip. The phone supports multimedia messages that are up to 100 KB in size. If the message contains a picture, the phone scales it down to fit the display area.

The default setting to receive multimedia messages (*Allow multimedia reception*) is generally set to *Yes* or *In home network*. See "Settings for text and e-mail messages" on page 42.

Multimedia messaging supports the following formats:

- Picture: JPEG, GIF, WBMP, BMP, and PNG.
- Sound: Scalable Polyphonic MIDI (SP-MIDI), AMR audio, and monophonic ringing tones.
- Video clips in 3GP format with SubQCIF and QCIF resolution and AMR audio.

The phone does not necessarily support all variations of these file formats. If a received message contains any unsupported elements, they may be replaced with the file name and the text *Object format not supported*.

You are not able to receive any multimedia messages if you have a call in progress or a game or another Java application running.

### **Write and send a multimedia message**

To modify multimedia messaging settings, see "Settings for text and e-mail messages" on page 42. To check availability and subscribe to the multimedia messaging service, contact your service provider.

Copyright protections may prevent some images, ringing tones, and other content from being copied, modified, transferred, or forwarded.

1. Select *Menu > Messages > Multimedia msgs. > Create message*.
2. Enter a message. See "Writing text" on page 30.
  - To insert a file in the message, select *Options > Insert* and select the desired option from the gallery, or select *Calendar note*, or *Business card*.  
To move the text component to the top or bottom of the message, select *Options > Place text first* or *Place text last*.
  - Your phone supports the sending and receiving of multimedia messages that contain several pages (slides). To insert a slide in the message, select *Options > Insert > Slide*. Each slide can contain text, one image, and one sound clip.

## Messages

If the message contains several slides, to open the desired one, select *Options > Previous slide*, *Next slide*, or *Slide list*. To set the interval between the slides, select *Slide timing*.

- The following options may also be available: *Delete* (to delete an image, slide, or sound clip from the message), *Preview*, or *Save message*. In *More options* the following options may be available: *Insert contact*, *Insert number*, *Message details*, and *Edit subject*.
3. To send the message, select *Send* or *Options > Send to e-mail* or *Send to many*.
  4. Enter the recipient's phone number or e-mail address, or search for it in *Contacts*.

While the multimedia message is being sent,  is displayed, and you can use other functions on the phone. If there is an interruption while the message is being sent, the phone tries to resend it a few times. If this fails, the message will remain in the *Outbox* folder, and you can resend it later.

The messages that you send are saved in the *Sent items* folder if the setting *Save sent messages* is set to *Yes*. Multimedia messages are indicated with .

For more information, see "Settings for multimedia messages" on page 42 .

### Read and reply to a multimedia message

When your phone receives a multimedia message, the indicator  and the text *Multimedia message received* are displayed. The appearance of a multimedia message may vary depending on the receiving device.

1. Select *Show* to view the message or select *Exit* to view it later.  
If more than one message is received, select the one that you want to read.  
An unread multimedia message is indicated by .
2. Scroll to view the message.  
See other options in *Gallery* ("Gallery" on page 66).

### Delete multimedia messages

To delete multimedia messages, select *Menu > Messages > Multimedia msgs. > Delete messages*. Select the folder from which you want to delete the messages and select *OK* to confirm.

### Multimedia folders

The phone saves the received multimedia messages in the *Inbox* folder. Multimedia messages that have not yet been sent are moved to the *Outbox* folder. The multimedia messages that you wish to send later can be saved in the *Saved items* folder.

The multimedia messages that have been sent are saved in the *Sent items* folder of the *Multimedia msgs.* submenu if the setting *Save sent messages* is set to *Yes*. For more information, see "Settings for multimedia messages" on page 42 .

### Messages memory full

When you have a new multimedia message waiting and the memory for the messages is full,  blinks, and *Multimedia message memory full, view waiting message?* is shown. To view the waiting message, select *Show*.

To save the message, select *Options > Save message*. To delete old messages, first select the folder, then the old message to be deleted. To discard the waiting message, select *Exit > Yes*; if you select *No*, you can view the message.

## ■ E-mail (network service)

You can write, send, and read e-mail with your phone. Your phone supports POP3 and IMAP4 e-mail servers. Before you can send and retrieve e-mail, you may need to do the following:

- Obtain an e-mail account or use your current one. Contact your service provider to confirm compatibility of e-mail providers.
- Contact your e-mail service provider to obtain the required e-mail settings.
- Set the e-mail settings on your phone. Select *Menu > Messages > Message settings > E-mail messages*. See "Settings for e-mail application" on page 43 .

## Messages

### Write and send an e-mail

1. Select *Menu* > *Messages* > *E-mail* > *Create SMS e-mail*.
2. Enter the recipient's e-mail address, a subject, and the e-mail message.
3. Select *Send*.



**Note:** When sending e-mail, your phone may display the words *E-mail message sent*. This is an indication that the e-mail has been sent by your phone to the e-mail server. This is not an indication that the e-mail has been received at the intended destination. For more details about e-mail services, check with your service provider.

### Download e-mail messages

1. To download e-mail that has been sent to your e-mail account, select *Menu* > *Messages* > *E-mail* > *Retrieve*.

To download new e-mail and send e-mail that has been saved in the *Outbox* folder, select *Menu* > *Messages* > *E-mail*. Select *Options* > *Retrieve e-mails*.

The phone connects to the e-mail service and downloads the messages to the *Inbox* folder.

2. Press *Select* to read the new message immediately or *Back* to read it later.

### Read the message later

From the menu, select *Messages* > *E-mail* > *Inbox* and the message you want to read. An unread text message is indicated by .

### Reply to an e-mail message



**Warning:** Exercise caution when opening messages. Messages may contain malicious software or otherwise be harmful to your device or PC.

1. While viewing a message, select *Options* > *Reply* or *Reply to all*.
2. Select *Original text* to include the original text in your reply or *Emptyscreen* to reply without the original text.
3. Confirm or edit the e-mail address, and write your reply.
4. Select *Send* to send the message.



### E-mail folders

Your phone saves e-mail that you have downloaded from your e-mail account in the *Inbox* folder. *Other folder* contains *Drafts* for saving unfinished e-mail, *Archive* for organizing and saving your e-mail, *Outbox* for saving e-mail that has not been sent, and *Sent items* for saving e-mail that has been sent.

### Delete e-mail

To delete e-mail, select *Menu* > *Messages* > *E-mail* > *Options* > *Delete messages*. To delete all messages from a folder, select the folder containing the messages and *Yes*. To delete all messages from all folders, select *All messages* > *Yes*. Deleting an e-mail from your phone does not delete it from the e-mail server.

### ■ Voice messages

The voice mailbox is a network service, and you may need to subscribe to it. For more information and for the voice mailbox number, contact your service provider.

Select *Menu* > *Messages* > *Voice messages* and one of the following:

*Listen to voice messages*—Call your voice mailbox.

*Voice mailbox number*—Enter, search for, or edit your voice mailbox number.

If supported by the network, the  indicates new voice messages. Select *Listen* to call your voice mailbox number.

Press and hold 1 to call your active voice mailbox if you have the number set.

### ■ Info messages

With the info message network service you may be able to receive messages on various topics. For details, contact your service provider.

### ■ Service commands

Select *Menu* > *Messages* > *Service commands*. Enter and send service requests (also known as USSD commands), such as activation commands for network services, to your service provider.

## Messages

### ■ Delete all messages from a folder

To delete all messages from a folder, select *Menu > Messages > Delete messages*. Select the folder from which you want to delete the messages and select *OK* to confirm.

If the folder contains unread messages, the phone will ask whether you want to delete them.

### ■ Message settings

The message settings affect the sending, receiving, and viewing of messages.

#### Settings for text and e-mail messages

1. Select *Menu > Messages > Message settings > Text message > Sending profile*.
2. Select the message profile that you want to change, and update the following settings as you choose: *Message center number* (delivered by your service provider), *Messages sent via*, *Message validity*, *Default recipient number* (text messages) or *E-mail server* (e-mail), *Delivery reports*, *Use GPRS*, *Reply via same center* (network service), and *Rename sending profile*.
3. Select *Back*.
4. Select *Save sent messages > Yes* to set the phone to save sent messages in the *Sent items* folder. If you select *No*, the sent messages are not saved.

#### Settings for multimedia messages

Select *Menu > Messages > Message settings > Multimedia msgs.*, and one of the following:

*Save sent messages*—Select *Yes* to set the phone to save sent multimedia messages in the *Sent items* folder. If you select *No*, the sent messages are not saved.

*Delivery reports*—Select *On* for the network to send delivery reports about your messages (network service).

*Scale image down*—Select *Yes* to change the image size when you insert an image into a multimedia message.

*Default slide timing*—Set the default time for slides in multimedia messages.

*Allow multimedia reception*—Choose *No*, *Yes*, or *In home network* to use the multimedia service. If *Allow multimedia reception* is set to *Yes* or *In home network*, your operator or service provider may charge you for every message you receive. The default setting to receive multimedia messages is generally on.

*Incoming multi-media messages*—Select *Retrieve* to set the phone to automatically get newly received multimedia messages, or select *Reject* if you do not wish to receive multimedia messages. This setting is not shown if *Allow multimedia reception* is set to *No*.

*Configuration settings*—Select *Configurations* and select the default service provider for retrieving multimedia messages. Select *Account* to see the accounts provided by the service provider. If more than one account is displayed choose the one that you want to use. You may receive the settings as a configuration message from the service provider. To key in the settings manually see "Configuration settings" on page 64 .

*Allow advertisements*—Select whether you want to allow your phone to receive advertisement messages. This setting is not shown if *Allow multimedia reception* is set to *No*.

### **Settings for e-mail application**

You may receive the e-mail application settings as a configuration message from the service provider. To enter the settings manually see "Configuration settings" on page 64 .

Select each of the settings individually, and enter all the required settings.

Contact your e-mail service provider for the settings.

Select *Menu > Messages > Message settings > E-mail messages* and one of the following:

*Configuration*—Select the set that you would like to activate.

*Account*—View the accounts provided by the service provider. If more than one account is displayed, choose the one that you want to use.

*My name*— Enter your name or nickname.

*E-mail address*—Enter your e-mail address.

*Include signature*—Define a signature that is automatically added to the end of your e-mail when you write a message.

*Reply-to address*—Enter the e-mail address to which you want the replies to be sent.

*SMTP user name*—Enter the name you want to use for outgoing e-mail.

## Messages

*SMTP password*—Enter the password you want to use for outgoing e-mail.

*Display terminal window*—Select *Yes* to perform manual user authentication for Intranet connections.

*Incoming server type*—Select either *POP3* or *IMAP4* depending on the type of e-mail system that you are using. If both types are supported, select *IMAP4*.

*Incoming mail settings*—If you selected *POP3* as the incoming server type, the following options are shown: *Retrieve e-mails*, *POP3 user name*, *POP3 password*, and *Display terminal window*.

If you selected *IMAP4* as the incoming server type, the following options are shown: *Retrieve e-mails*, *Retrieval method*, *IMAP4 user name*, *IMAP4 password*, and *Display terminal window*.

### Other settings

Select *Menu > Messages > Message settings > Other settings > Font size* to set the font size for reading and writing messages.

### Message counter

To view how many messages you have sent and received, select *Menu > Messages > Message counter*. Select *Sent messages* or *Received messages*, or select *Clear counters* to clear the counters.

## 9. Instant messages

---

Take text messaging to the next level by experiencing instant messaging (IM) in a wireless environment. Engage in instant messaging with friends and family, regardless of the mobile system or platform they are using (like the Internet), as long as you all use the same IM service. Check with your wireless service provider for availability.

Before you can start using IM on your phone, you must first subscribe to your wireless service provider's text messaging service. GPRS network service is required to use instant messaging. You must also register with the IM service you want to use. See "Register with an IM service" on page 45 for more information.



**Note:** Depending on both your IM service provider and your wireless service provider, you may not have access to all of the features described in this guide.

### ■ Register with an IM service

Before you can use IM, you must register with an IM service to obtain an IM user name and password. You can obtain an IM user name and password by registering over the Internet (using your computer) with the IM service provider you have selected. During the registration process, you will have the opportunity to create the user name and password of your choice. For more information about signing up for IM services, contact your wireless service provider.

### ■ IM icons and menu items

Each IM service provider has its own unique interface, so the IM menu items, screen display text, and icons on your phone may appear differently for each IM service. If you have questions about the differences in the various IM service providers' screen text and icons, contact your wireless service provider for more information.

### ■ IM menus

#### Offline

When you select */M* from your phone menu, a list of available IM services is displayed. Select the desired IM service to access the IM offline menu options:

## Instant messages

[Login](#), [Saved convers.](#), and [Settings](#). Depending on the IM service provider you are using, these may not be the exact menu items displayed. See "IM icons and menu items" on page 45 .

### Online

After you log into IM, the following IM online menu options appear: [Conversations](#), [IM contacts](#), [Add contact](#), [Create group](#), [Saved convers.](#), [Availability](#), [Settings](#), [Blocked list](#), [Logout](#). Depending on the IM service provider you are using, these may not be the exact menu items displayed. For more information, see "IM icons and menu items" on page 45 .

### ■ Log in

1. Select [Menu](#) > [IM](#).
2. Select the IM service you want to log into.  
You must select the IM service every time you log in.
3. Select [Login](#).
4. At the prompt, enter your user name if it is not already displayed, and select [OK](#).
5. At the prompt, enter your password, and select [OK](#).

Depending on your IM service, you may not need to enter your user name and password manually every time you log in.

After you have logged into IM the first time, you can choose to log in automatically or you can continue logging in manually. See the [Automatic login](#) option under "IM settings" on page 49 .

### ■ Begin an IM session

You can send instant messages to anyone if you have the person's user name and you use the same IM service. As the conversation progresses, the most recent message appears at the top of the screen, causing the previous messages to move down one level (some IM services may do this in the opposite direction).

If you want to chat with a person, you must first add that person to [IM contacts](#). See "IM contacts" on page 48 .

To begin an IM session with one contact, do the following:

1. From the [IM](#) online menu, select [IM contacts](#).

2. Scroll to a contact who is online, and select *Select > Open*.  
A conversation screen is opened, and the contact's name is displayed at the top.
3. Select *Write*, and enter a message. See "Writing text" on page 30.
4. When you finish the message, select *Send*.

### ■ Begin a group chat

You can create your own private chat groups. The participants must be entered into *IM contacts*. See "IM contacts" on page 48.

1. From the *IM* online menu, select *Create group*.
2. Enter the group name (up to 10 characters), and select *OK*.
3. After your screen name appears, select *OK*.  
The group chat screen is displayed.
4. To add group members, select *Options > Group members*.
5. Select the contact whom you want to invite to the group chat.
6. Enter the invitation text, and select *Send*.

### ■ Receive and reply to messages

If you have an active chat open and receive an instant message from the contact or group member with whom you are chatting, the new message is displayed on the conversation screen in the sequence in which they are received. Select *Write* to reply.

If you receive an instant message when you have the IM application open but do not have an active chat open, a screen appears showing you have a new instant message with the name of the sender. Select *Open* to open the conversation screen with that contact's new message displayed. To reply, select *Write*, enter a message, and select *Send*.

If you receive an instant message when you are logged in to the IM service but do not have the IM application open on your phone, a message is displayed telling you that a new IM message has been received. Select *Start* to open the IM application and view the new message.

## Instant messages

### ■ Return to chat session

From the *IM* online menu, select *Conversations*. This list displays all IM conversations and group chats in which you are currently participating. To view a conversation or continue chatting, scroll to a group name or contact name, and press *Select*.

### ■ IM contacts

You can add the names of contacts with whom you interact frequently by instant messaging to the *IM contacts* list.

#### Add a new contact

To add a person to *IM contacts* during an instant messaging session, select *Options > Add*.

To add a new contact from the IM online menu, select *Add contact*. Enter the contact's user name for the IM service, and select *OK*. Enter a nickname for the contact, and select *OK*. The contact is added to your *IM contacts* list.

To add a new contact from the IM contacts list, select any contact to open the IM contacts menu. Select *Add contact*, enter the contact's user name for the IM service, and select *OK*. Enter a nickname for the contact, and select *OK*. The contact is added to your *IM contacts* list.

#### Remove a contact

From the *IM* online menu, select *IM contacts* and the contact you want to remove; then select *Remove contact > OK*.

#### Block or unblock contacts

To block or unblock instant messages from a contact, select *IM contacts* from the IM online menu, the contact name, and *Block contact* or *Unblock > OK*.

To view a list of the contacts you have blocked, select *Blocked list* from the IM online menu.

### ■ Save chat session

You can save a chat session while you have the conversation open. Select *Options > Save*, edit the name if desired, and select *Save*.



To view a saved chat session, go to the IM online menu, select *Saved convers.* and the desired conversation name to open it for viewing. While viewing the saved conversation, you can select *Delete* or *Options > Rename*.

### ■ Set your availability

You can determine if other users can tell whether you are available or not. From the *IM* online menu, select *Availability > Available for all, Avail. for contacts, or Appear offline*.

### ■ IM settings

You can customize your IM settings, depending upon the IM service you have selected. From the IM online menu, select *My settings* and one of the following:

*Screen name*—Enter a screen name (also called an alias or a nickname) that is 1–20 characters in length. This name is shown in front of the messages that you send to your contacts. It is also your default screen name when you join a group chat.

*Automatic login*—You can use automatic login after you have logged in at least once to an IM service with your user name and password. When you select *IM* from the phone main menu and then select the same IM service provider, you are then logged in automatically and do not have to enter your user name and password.

*Sort contacts*—Specify whether you want your IM contacts to be displayed *Alphabetically* or *By status*.

*Status updates*—Select *On* if you want your IM contacts list to be updated when a contact's availability changes. If you set this feature to *Off*, you can select *Refresh list* from the IM contacts menu to update your contacts' status manually.

*Network*—Modify network connection settings for the IM service.

### ■ Log off service

#### Exit instant messaging

From the IM online menu, you can exit the IM application but still be connected to the IM service. Select *Back* until the IM online menu appears; then select *Exit*. If you open *IM* again, you do not need to log in again.

## I n s t a n t m e s s a g e s

You can then receive instant messages and chat invitations from your contacts when using your phone for other purposes, such as playing a game. If you are connected to your IM service, but you have not used your IM application for some time, you may be automatically disconnected from the IM service. The next time you open the IM application, *Not connected* is displayed, and you are taken to the offline menu where you have to log in again.

### Log out of instant messaging

To disconnect from the IM service, you must log out from the online menu. You will be taken to the IM service provider list, where you can exit the IM application or select an IM service and log in again.

From the IM online menu, select *Logout* > *OK*.

## 10. Call log

---



The phone logs the phone numbers of missed, received, and dialed calls, and the approximate length of your calls. To log this information, the phone must be switched on and within the network's service area, and the network must support these functions.

To view recent call logs, select *Menu > Call log > Missed calls, Received calls, or Dialed numbers*.

When viewing a list, select *Options* to view the date and the time of the call, edit or delete the phone number from the list, save the number in *Contacts*, or send a message to the number.

### ■ Delete log contents

To delete recent call lists, select *Menu > Call log > Delete recent call lists > All, Missed, Received, or Dialed*.

### ■ Counters and timers



**Note:** The actual invoice for calls and services from your service provider may vary, depending upon network features, rounding off for billing, taxes, and so forth.

Select *Menu > Call log > Call timers, GPRS data counter, or GPRS connection timer* for approximate information on your recent communications.

## 11. Contacts

---

You can save names and phone numbers (contacts) in the phone memory and in the SIM card memory.



- The phone memory may save names with numbers and text notes about each name. You can also save an image for a certain number of names.
- Names and numbers saved in the SIM card memory, are indicated by .

If you subscribe to the presence service, you can set up your contacts list to publish your current availability status (network service). Your status information is communicated to anyone who has access to the presence service and who is requesting this information. See "My presence" on page 54 and "Subscribed names" on page 56.

### ■ Contact settings

Select *Menu > Contacts > Settings > Memory in use, Contacts view, or Memory status*.

### ■ Add contact

Select *Menu > Contacts > Add new contact*. Enter the name and the phone number. When the name and number are saved, select *Done*.

### ■ Add numbers, text items, or an image

You can save different types of phone numbers, short text items, and an image per name in the internal phone memory for contacts.

The first number saved is automatically set as the default number, and it is indicated with a frame around the number type indicator, for example . When you select a name from contacts to make a call, the default number is used unless you select another number.

1. Make sure that the memory in use is either *Phone* or *Phone and SIM*. See "Contact settings" on page 52.
2. Open your contacts list and scroll to the contact you want to modify.
3. Select *Details > Options* and one of the following:

*Add number*—Select one of the number types, enter the number, and select *OK* to save it. To set the selected number as the default number, select *Set as default*.

*Add detail*—Select one of the text types, enter the text (see "Writing text" on page 30 ), and select *OK* to save it. If you select *User ID*, select *Search* to find an ID by a mobile phone number or an e-mail address if you are connected to the presence service. See "My presence" on page 54 . If only one ID is found, it is automatically saved. Otherwise, to save the ID, select *Options > Save*. To enter the ID, select *Enter ID manually*. Enter the ID, and select *OK* to save it.

*Add image*—When you select this option, *Gallery* is opened automatically so that you can choose the image. Open the image you want to add, and select *Options > Save to contacts*.

4. Select *Back > Exit* to return to the standby mode.

To change the number or text type, select *Change type* in the options list. You cannot change the type of an ID when it is on the *IM contacts* or in the *Subscribed names* list.

## ■ Search for a contact

Select *Menu > Contacts > Find*, or to find a contact name quickly, scroll down in the standby mode. You can enter the first characters of the name you are searching for in the pop-up window.

## ■ Contact options

The following options may also be available in the *Contacts* menu:

*Add new contact* and *Delete*.

*Copy*—Copy names and phone numbers between the phone contact directory and the SIM card memory.

*Settings*—Select how the names and numbers are displayed, and view the free and used memory capacity. See "Contact settings" on page 52 .

*1-touch dialing*—Assign a number to a 1-touch dialing key. To activate 1-touch dialing see "1-touch dialing" on page 58 .

*Info numbers*—Call the information numbers of your service provider if the numbers are included on your SIM card (network service).

## Contacts

**Service numbers**—Call the service numbers of your service provider if the numbers are included on your SIM card (network service).

**My numbers**—View the phone numbers assigned to your SIM card. Only shown, if the numbers are included on your SIM card.

**Caller groups**—Arrange the names and phone numbers saved in the memory into caller groups with different ringing tones.

### ■ Edit or delete details

1. Search for the contact that you want to edit or delete, and select *Details*.
2. Scroll to the name, number, text item, or image that you want to edit or delete, and select *Options*.
3. Select *Edit name*, *Edit number*, *Edit detail*, *Change image*, *Delete number*, *Delete detail*, or *Delete image*.

You cannot edit or delete an ID when it is in *IM contacts* or in the *Subscribed names* list.

Deleting an image attached to the contact does not delete it from *Gallery*.

### ■ My presence

With the presence service (network service) you can share your presence status with other users with compatible devices and access to the service. Presence status includes your availability, status message, and personal logo.

Other users who have access to the service and who are requesting your information are able to see your status. The requested information is shown in *Subscribed names* in the viewers *Contacts* menu. You can personalize the information that you want to share with others and control who can see your status.

Before you can use presence, you need to subscribe to the service. Contact your service provider to check the availability and charging details, subscribe to the service, and receive your unique ID and password and the settings for the service.

While connected to the presence service, you can use the other functions of the phone, and the presence service is active in the background.



### Log in and out of the presence service

Select *Menu* > *Contacts* > *My presence* > *Connect to 'My presence' service* or *Disconnect*.

### Update your presence status

Select *Menu* > *Contacts* > *My presence* > *My current presence*, and one of the following:

*View current presence*—Select *Private pres.* or *Public pres.*

*My availability*—Set your availability status to *Available* () , *Busy* () , or *Not available* () .

*My presence message*—Key in the text shown to other persons; or select *Options* > *Previous msgs.*, and select an old message as the status message.

*My presence logo*—Select your personal logo from the *Graphics* folder in the gallery. If you select *Default*, the logo is not published.

*Show to*—Assign the groups who can see your presence status, or choose not to show it at all. Select from the following:

- *Private and public*—Contacts in your private list are able to see all your presence information (availability, status message, and logo). Other contacts can see only your availability.
- *Private viewers*—Contacts in your private list can see all your presence information (availability, status message, and logo). Other users will not see any information.
- *No one*—No one can see your presence information.

### Viewers lists

To see who is allowed to view your presence information, select *Menu* > *Contacts* > *My presence* > *Viewers*, and one of the following:

*Current viewers*—Check all the persons who have subscribed to your presence information.

*Private list*—Check the list of persons who are allowed to view all your presence information, including availability, status message, and logo. You can manage your own private list. Other persons who are not in the private list can see only your availability.

## C o n t a c t s

*Blocked list*—View the list of persons you have blocked from viewing your presence information.

### **Presence settings**

Select *Menu* > *Contacts* > *My presence* > *Settings*, and one of the following:

*Show current presence in idle*—Select *On* to display the current status indicator in the standby mode.

*Synchronize with profiles*—Select *On* to update *My presence message* and *My availability* manually or automatically by linking them to the currently active profile. Refer also to "Profiles" on page 56. You cannot link a personalized status logo to a profile.

*Connection type*—Select whether the phone connects automatically to the service when the phone is switched on.

*IM and my presence settings*—View and modify your IM and presence account settings.

### **■ Subscribed names**

You can stay informed of your contacts' presence status by creating a list of subscribed contacts. You can view the contacts' presence status unless the contact or network prevents it.

To use this feature, you and the contact(s) you wish to view must subscribe to the presence service (see "My presence" on page 54 ). The memory in use must be either *Phone* or *Phone and SIM* for this feature to work (see "Contact settings" on page 52 ).

To connect to the presence service, select *Menu* > *Contacts* > *My presence* > *Connect to 'My presence' service*.

### **Add contacts to subscribed names**

1. Select *Menu* > *Contacts* > *Subscribed names*. If you have not connected to the presence service, the phone asks if you want to connect now.
2. If you have no contacts on your list, select *Add*. Otherwise, select *Options* > *Subscribe new*. The list of your contacts is shown.
3. Select a contact from the list, and if the contact has a user ID saved, the contact is added to the subscribed names list. If there is more than one ID, select one of them.



After subscription of the contact, *Subscription activated* is shown.

### **View subscribed names**

You can view the subscribed names either by scrolling through the contacts or by the *Subscribed names* menu.

Select *Menu > Contacts > Subscribed names*. The first contact on the subscribed names list is displayed and the following status information is shown:

- Text describing the contact's availability (if the person chooses to define it)
- Icons that indicate the contact's presence status  
The icon  indicates that the person's presence information is not available.

Select *Details* to view the details of the selected contact, or select *Options* and one of the following:

*Subscribe new*—Add a new contact to the list of subscribed names.

*Chat*—Start a conversation.

*Send message*—Send a text message to the selected contact.

*Send SMS e-mail*—Send an e-mail to the selected contact.

*Send bus. card*—Send a business card to the selected contact.

*Unsubscribe*—Remove the selected contact from the list of subscribed names.

### **Unsubscribe a contact**

To unsubscribe a contact from the *Contacts* list, scroll down in the standby mode, and scroll to the contact that you want to unsubscribe. Select *Details*, select the ID, and select *Options*. To unsubscribe, select *Unsubscribe > Yes*.

To use the *Subscribed names* menu to unsubscribe, see "View subscribed names" on page 57 .

### **■ Send and receive a business card**

You can send and receive a person's contact information as a business card if you are using a compatible device. When you have received a business card, select *Show > Save* to save the business card in the phone memory. To discard the business card, select *Exit > Yes*.

To send a business card:

## C o n t a c t s

1. In *Contacts*, search for the name and phone number that you want to send.
2. Select *Details > Options > Send bus. card*.
3. Select *Via text message* (network service), *Via multimedia* (network service), or *Via Bluetooth*.
4. Select *Primary number* or *All details*.

### ■ 1-touch dialing

To assign a number to a 1-touch dialing key:

1. Select *Menu > Contacts > 1-touch dialing*, and scroll to a key number.
2. Select *Assign*, or if a number has already been assigned to the key, select *Options > Change*.
3. Select *Find*, and select first the name and then the number that you want to assign.

If the *1-touch dialing* function is off, the phone asks whether you want to activate it. See also *1-touch dialing* in "Call settings" on page 62 .

To use 1-touch dialing, hold down the desired 1-touch dialing enter the standby mode.

### ■ Voice dialing

You can make a phone call by saying a voice tag that has been added to a phone number. Any spoken words, such as a person's name, can be a voice tag. You can add up to 10 voice tags.

Important notes about voice tags:

- Voice tags are not language-dependent. They are dependent on the speaker's voice.
- You must say the name exactly as you said it when you recorded it.
- Voice tags are sensitive to background noise. Record voice tags and use them in a quiet environment.
- Very short names are not accepted. Use long names and avoid similar names for different numbers.



**Note:** Using voice tags may be difficult in a noisy environment or during an emergency, so you should not rely solely upon voice dialing in all circumstances.

### **Add and manage voice tags**

Save or copy in the phone memory the contacts to which you want to add a voice tag. You can also add voice tags to the names in the SIM card, but if you replace your SIM card with a new one, you first need to delete the old voice tags before you can add new ones.

1. Scroll down in the standby mode to open your contact list.
2. Scroll to the contact to which you want to add a voice tag, and select *Details*.
3. Scroll to the phone number you want, and select *Options > Add voice tag*.
4. Select *Start*, and say clearly the words you want to record as a voice tag.

After recording, the phone plays the recorded tag.  appears after the phone number with a voice tag.

To check the voice tags, select *Menu > Contacts > Voice tags*. Scroll to the contact with the voice tag that you want, and press *Select* to see the options to listen to, delete, or change the recorded voice tag.

### **Make a voice tag call**

In the standby mode, press and hold the *Right selection key*. A short tone is played, and *Speak now* is displayed. Say the voice tag clearly. The phone plays the recognized voice tag and dials the voice tag phone number after 1.5 seconds.

## 12. Settings



### ■ Profiles

Use *Profiles* to adjust and customize ringing tones and sound tones for different events and environments. You can customize the profiles to your own liking, and activate a profile to use it. Available profiles are *Normal*, *Silent*, *Meeting*, *Outdoor*, *My profile 1*, and *My profile 2*.

Select *Menu* > *Settings* > *Profiles*. Select a profile, and:

*Activate*—Activates the selected profile, select.

*Customize*—Personalizes the profile. Select the setting you want to change, and modify it as you choose.

*Timed*—Sets the profile to be active until a certain time up to 24 hours. Set the time for the profile setting to end. When the time set for the profile expires, the previous profile that was not timed becomes active.

### ■ Themes

A theme is a package that may include a screen saver, a wallpaper image, a ringing tone, and a color scheme to customize your phone for different events and environments. Themes are stored in *Gallery*. To activate a theme do the following:

1. Select *Menu* > *Settings* > *Themes* > *Select theme*.

The gallery is automatically opened so that you can locate a theme.

2. Open the *Themes* folder, scroll to a theme, and select *Options* > *Apply theme*.

See "Gallery" on page 66.

To download new themes, select *Menu* > *Settings* > *Themes* > *Theme downloads*. See "Download" on page 81.

### ■ Tone settings

To change the tone settings for the active profile, select *Menu* > *Settings* > *Tone settings*. Select and change *Incoming call alert*, *Ringing tone*, *Ringing volume*, *Vibrating alert*, *Message alert tone*, *Instant message alert tone*, *Keypad tones*, and *Warning tones*. You can find the same settings in the *Profiles* menu, see "Profiles" on page 60.

Select *Alert for* to set the phone to ring only upon calls from phone numbers that belong to a selected caller group. Scroll to the caller group you want to select or choose *All calls* > *Mark*.

## ■ Personal shortcuts

With personal shortcuts you get quick access to frequently used phone functions.

### Right selection key

Select *Menu* > *Settings* > *Personal shortcuts* > *Right selection key* and a phone function from the list to assign to the key. Refer also to "Start screen (standby mode)" on page 18. This menu is not shown in some operator variants.

### Go to options

To assign phone functions from a predefined list to the *Go to* shortcut list, select *Go to* > *Options* > *Select 'Go to' options*.

Select *Go to* > *Options* > *Organize 'Go to' options* to rearrange the functions on your personal shortcut list. Refer also to "Start screen (standby mode)" on page 18.

### Voice commands

You can activate certain phone functions by saying a voice command. Up to five functions can be selected for voice commands.

Select *Menu* > *Settings* > *Personal shortcuts* > *Voice commands*. Select the function folder that you want, scroll to the function to which you want to add a voice command, and select *Add*. A voice command is indicated with .

When you are using voice commands, the same guidelines in "Make a voice tag call" on page 56" apply.

## ■ Time and date settings

Select *Menu* > *Settings* > *Time and date settings*, and one of the following:

*Clock*—Set the phone to show the clock in the standby mode, adjust the clock, and select time zone and the time format.

*Date*—Set the phone to show the date in the standby mode, set the date, and select the date format and date separator.

## Settings

*Auto-update of date & time* (network service)—Set the phone to automatically update the time and date according to the current time zone.

### ■ Display settings

Select *Menu* > *Settings* > *Display settings* and one of the following:

*Wallpaper*—Set your phone to display a background image, known as wallpaper, when the phone is in the standby mode.

*Screen saver*—Press *Select s. saver* to choose an animation or a still image as screen saver from *Gallery*. Select in *Time-out* the time after which the screen saver will be activated. Select *On* to activate the screen saver.

Independent of the screen saver settings, for power saving purposes, a digital clock view will be activated when no function of the phone has been used for a certain time.

*Color schemes*—Change the color in some display components, such as indicators, the signal bar, the battery bar, and the background image that appears when using a menu function.

*Menu view*—Set the way the phone displays the main menu.

*Operator logo*—Set your phone to display or hide the operator logo.

### ■ Call settings

Select *Menu* > *Settings* > *Call settings* and one of the following:

*Call forwarding* (network service)—Forward your incoming calls. For details, contact your service provider.

*Anykey answer*—Select *On*, and you can answer an incoming call by briefly pressing any key, except *Power*, or *End*.

*Automatic redial*—Select *On*, and your phone will make a maximum of 10 attempts to connect the call after an unsuccessful call attempt.

*1-touch dialing*—Select *On*. To dial the names and phone numbers assigned to the 1-touch dialing keys from *2* to *9*, press and hold the corresponding number key.

*Call waiting*—Select *Activate* for the network to notify you of an incoming call while you have a call in progress (network service).

*Summary after call*—Select *On*, and the phone will briefly display the approximate duration and cost (network service) of the call after each call.

*Send my caller ID* (network service)—Select *Set by network*, *Yes*, or *No*.

*Line for outgoing calls* (network service)—Select phone line 1 or 2 for making calls. This option is shown only if supported by your SIM card.

## ■ Phone settings

Select *Menu* > *Settings* > *Phone settings* and one of the following:

*Phone language*—Set the display language of your phone. If you select *Automatic* the phone selects the language according to the information on the SIM card.

*Memory status*—View the amount of free, used, and total amount of memory for each function. You may also find memory information in the menus of some functions.

*Automatic keyguard*—Set the keypad of your phone to lock automatically after a preset time delay when the phone is in the standby mode and no function of the phone has been used. Select *On*, and you can set the time from 5 seconds to 60 minutes.

When the keyguard is on, calls still may be possible to the official emergency number. Key in the emergency number, and press Call.

*Security keyguard*—See "The security keyguard" on page 28 .

*Cell info display*—Select *On* to receive information from the network, depending on the network cell used (network service).

*Welcome note*—Key in the note you would like to be shown briefly when the phone is switched on. To save the note, select *Save*.

*Operator selection*—Select *Automatic*, and the phone automatically selects one of the cellular networks available in your area. Select *Manual*, and you can select a network that has a roaming agreement with your service provider.

*Confirm SIM service actions*—See "SIM services" on page 27 .

*Help text activation*—Select whether the phone shows the help texts.

*Start-up tone*—Select whether the phone plays a start-up tone when switched on.

## ■ Enhancement settings

The enhancement settings menu is shown only if the phone is or has been connected to a compatible mobile enhancement, charger, or hands-free unit.

## Settings

Select *Menu > Settings > Enhancement settings*. You can select an enhancement menu if the corresponding enhancement is or has been connected to the phone.

### ■ Configuration settings

Some of the network services need to have the correct configuration settings on your phone. Get the settings from a service provider as a configuration message, or enter your personal settings manually. Configuration settings from up to 10 different service providers can be stored in the phone and can be managed within this menu.

Select *Menu > Settings > Configuration settings* and one of the following:

*Default configuration settings*—View the list of service providers stored on the phone (the default service provider is highlighted), and select another service provider as default. Scroll to a provider, and select *Details* to view the list with supported applications. To delete a service provider from the list, select *Options > Delete*.

*Activate default in all applications*—Set the applications to use the settings from the default service provider.

*Preferred access point*—Select another access point. Normally the access point from your service provider is to be used.

To enter, view, and edit the settings manually, select *Menu > Settings > Configuration settings > Personal configuration settings*. To add a new configuration, select *Add new* or *Options > Add new*. Choose one of the application types from the list and enter all the necessary settings. To activate the settings, select *Back*.

To view or to edit the user-defined settings, select the application that you want to view, and select the setting to edit.

### ■ Security settings

When security features that restrict calls are in use (such as call restriction, closed user group, and fixed dialing) calls still may be possible to the official emergency number programmed into your device.

Select *Menu > Settings > Security settings* and one of the following:

*PIN code request*—Set the phone to request your PIN code every time the phone is switched on. Some SIM cards do not allow the PIN code request to be turned off.

*Call restrictions* (network service)—Restrict incoming calls to and outgoing calls from your phone. A restriction password is required.



## Settings

*Fixed dialing*—Restrict your outgoing calls to selected phone numbers if this function is supported by your SIM card.

*Closed user group* (network service)—Specify the group of people whom you can call and who can call you.

*Security level*—Select *Phone* for phone to request the security code whenever a new SIM card is inserted. Select *Memory* for the phone to request the security code when the SIM card memory is selected and you want to change the memory in use.

*Access codes*—Change the security code, PIN code, PIN2 code, or restriction password.

### ■ Restore factory settings

To reset some of the menu settings to their original values, select *Menu > Settings > Restore factory settings*.

## 13. Gallery



In this menu, you can manage graphics, images, video clips, recordings, themes, and tones. These files are arranged in folders.

Your phone supports a Digital Rights Management (DRM) system to protect acquired content. A piece of content (for example, a ringing tone) can be protected and associated with certain usage rules (for example number of usage times and a certain usage period). The rules are defined in the activation key of the content, which can be delivered either together with the content or independently, depending on the service provider. You may be able to update these activation keys. Always check the delivery terms of any content and activation key before acquiring them, as they may be subject to a fee.

Copyright protections may prevent some images, ringing tones, and other content from being copied, modified, transferred, or forwarded.

1. Select *Menu* > *Gallery*.

A list of folders is displayed. *Images*, *Video clips*, *Themes*, *Graphics*, *Tones*, and *Recordings* are the default folders on the phone.

2. Scroll to a folder, and select *Open* to view a list of files in the folder or *Options* to choose from additional options.
3. After you open a folder, select the file that you want to view, and select *Open*.  
If you selected the *Themes* folder, scroll to a theme, and select *Open* > *View* to view the theme package. To choose it as your theme, select *Options* > *Apply theme*.
4. After you open a file, you can select *Options* to choose from additional options.

## 14. Camera

---

### ■ Built-in camera

You can take photos or record video clips with the built-in camera. The camera produces pictures in JPEG format and the video clips in 3GP format.

The Nokia 6822b device supports an image capture resolution of 640 x 480 pixels. The image resolution in these materials may appear different.

#### Photos and video clips

Select *Menu* > *Camera*. The live image appears on the display, and you can use the display as a viewfinder. Scroll left and right to change the camera mode: *Standard photo*, *Portrait photo*, or *Video*, or *Night mode* (if the lighting is dim for taking photos). If you want to add the photo to a name or a phone number saved in contacts, select *Portrait photo*.



#### Take a photo

Select *Capture*. A shutter sound is heard. The phone saves the photo in the *Images* folder of the *Gallery* menu.

If you want to send the photo as a multimedia message, select *Send*.

Select *Back* to take another photo or *Options* and select an option to rename or zoom the saved photo, set the contrast, see the details, set the photo as wallpaper, open the gallery, or delete the photo.

You can activate the self-timer of the camera for one picture at a time. Put the camera in photo mode, select *Options* > *Self-timer* > *Start*, and after the timeout, the camera takes the photo. While the self-timer is running, a beeping sound is heard.

#### Record a video

To start recording a video clip, select *Record*. When you are recording a video clip, the remaining recording time is shown on the top of the display.

To pause the recording, select *Pause*. To resume the recording, select *Continue*. To stop the recording, select *Stop*. The phone saves the recording in the *Video clips* folder of the *Gallery* menu. To view the recorded video clip, select *Play*.

## Camera

Select [Back](#) to start recording a new video clip or [Options](#), and select an option to delete or rename the saved video clip, set the contrast, see the details, send it as a multimedia message, open the gallery, or mute/unmute the microphone.

### Camera settings

Select [Menu](#) > [Camera](#) > [Options](#). Depending on the active camera mode, the following options may appear: [Change mode](#), [Self-timer](#), [Mute/Unmute](#), [Open Gallery](#), [Settings](#) (to adjust the camera settings), [Default mode](#), [Image quality](#), [Video clip length](#), [Camera sounds](#), [Self-timer lights](#), and [Default title](#).

## ■ Voice recorder

You can record pieces of speech, sound, or an active call for up to 1 minute and 40 seconds. This is useful when recording a name and phone number to write down later.

The recorder cannot be used when a data call or GPRS connection is active.

### Record

1. Select [Menu](#) > [Applications](#) > [Extras](#) > [Voice recorder](#).
2. To start the recording, select [Record](#). To start the recording during a call, select [Options](#) > [Record](#).

While recording a call, all parties to the call will hear a faint beeping sound every 5 seconds approximately.

3. To end the recording, select [Stop](#).  
The recording is saved in the [Recordings](#) folder of the [Gallery](#) menu.
4. To listen to the latest recording, select [Play last recorded](#).
5. To send the latest recording, select [Send last recorded](#).

### List of recordings

Select [Menu](#) > [Applications](#) > [Extras](#) > [Voice recorder](#) > [Recordings list](#). The list of folders in the [Gallery](#) is shown. Open [Recordings](#) to see the list with recordings.

## 15. Organizer

---

### ■ Alarm clock



You can set the phone to sound an alarm at a desired time.

Select *Menu* > *Organizer* > *Alarm clock*.

To set the alarm, select *Alarm time*, and enter the alarm time. To change the alarm time when the alarm time is set, select *On*. Select *Repeat alarm* to set the phone to alert you on selected days of the week.

Select *Alarm tone* and select the default alarm tone to customize the alarm tone, select one from the ringing tone list or from *Gallery*.

When the alarm time expires, the phone sounds an alert tone and flashes *Alarm!* and the current time on the display, even if the phone is switched off. Select *Stop* to stop the alarm. If you let the phone continue to sound the alarm for a minute or select *Snooze*, the alarm stops for about 10 minutes, then resumes.

If the alarm time is reached while the device is switched off, the device switches itself on and starts sounding the alarm tone. If you Select *Stop*, the device asks whether you want to activate the device for calls. Select *No* to switch off the device or *Yes* to make and receive calls. Do not select *Yes* when wireless phone use may cause interference or danger.

### ■ Calendar

Select *Menu* > *Organizer* > *Calendar*.

The current day is indicated by a frame. If there are any notes set for the day, the day is in bold type. To view the day notes, select *View*. To view a week, select *Options* > *Week view*. To view a single note, select *View*.





Other options for the calendar view may be options to create a note; delete, edit, move, and repeat a note; copy a note to another day; or send a note directly to another compatible phone as a note, text message, or a multimedia message.

In *Settings* you can set the date, time, time zone, date and time format, and the first day of the week. In the *Auto-delete notes* option you can set the phone to delete old notes automatically after a specified time.

To delete all notes in the calendar, select the month or week view and select *Options* > *Delete all notes*.

## Organizer

### Make a calendar note

Select *Menu* > *Organizer* > *Calendar*. Scroll to the date you want, and select *Options* > *Make a note*. Select one of the following note types:  *Meeting*,  *Call*,  *Birthday*,  *Memo*, or  *Reminder*.

### Calendar note alarms

The phone must be turned on to sound a calendar note alarm tone. If you want to set an alarm that will sound while the phone is turned off, see "Alarm clock" on page 69.

When the phone sounds an alarm for a calendar note, the phone beeps, and displays the note. With a call note  on the display, you can call the displayed number by pressing *Call*. To stop the alarm and view the note, select *View*. Select *Snooze*, and the phone sounds an alarm again after 10 minutes. To stop the alarm without viewing the note, select *Exit*.

### ■ To-do list

You can save a note for a task that you have to do, select a priority level for the note, and mark it as done when you complete it. You can sort the notes by priority or by date.

Select *Menu* > *Organizer* > *To-do list*.

Select *Add note* to make a note. Enter the note, and select *Save*. Select the priority for the note. The phone automatically sets the deadline without an alarm for the note. To change the deadline, view the note, and select the deadline option.

When viewing a note, you can select *Options* to view and delete the selected note and delete all the notes that you have marked as done. You can sort the notes by priority or by deadline, send a note to another phone, save a note as a calendar note, or access the calendar. You can also select an option to edit the selected note, edit the deadline or priority for the note, or mark the note as done.

### ■ Notes

You can use this application for writing and sending notes to compatible devices by MMS.

Select *Menu* > *Organizer* > *Notes*. The phone will ask you to set the date and time if they have not already been set when you start to write a note. To add a note,

select [Add note](#). Enter the note, and select [Save](#); or scroll to a note, and select [View](#) or [Options](#) to see the options for notes.

## ■ Synchronization

Synchronization allows you to save your calendar and contacts data on a remote Internet server (network service) or on a compatible PC. If you have saved data on the remote Internet server, you can synchronize your phone by starting the synchronization from your phone. You can also synchronize the data in the contacts list, calendar, and notes of your phone to correspond to the data of your compatible PC by starting the synchronization from your PC.

The contact data in your SIM card will not be synchronized.

### Synchronize from your phone

Before synchronizing from your phone, you need to subscribe to a synchronization service and get the configuration settings from your service provider. For more information on availability and the synchronization service settings, contact your service provider.

To start the synchronization from your phone, do the following:

1. Activate the connection settings you need for the synchronization. See "Synchronization settings" on page 71.
2. Select [Menu](#) > [Organizer](#) > [Synchronization](#) > [Server sync](#) > [Data to be synchronized](#), mark the data to be synchronized, and select [Done](#) > [Synchronize](#).

The marked data of the active set will be synchronized after confirmation.

### Synchronization settings

You may receive the synchronization settings for your phone as a configuration message from the service provider. For more information on availability and the synchronization service settings, contact your service provider. To enter the settings manually, see "Configuration settings" on page 64.

Select [Menu](#) > [Organizer](#) > [Synchronization](#) > [Server sync](#) > [Sync settings](#) > [Configuration](#). Select the service provider whose settings you want to activate, and press [Select](#). Select [Account info](#) to see the accounts provided by the service provider. If more than one account is displayed, choose the one you want to use.

## Organizer

### Synchronize from your compatible PC

You must use Bluetooth, Infrared, or a data cable to connect your phone to a PC to synchronize contacts, the calendar, and the notes from your PC. To view compatible data cables, see "Enhancements" on page 92 . You also need the PC Suite software of your phone installed on the PC. Start the synchronization from the PC using PC suite.

Verify that the phone is in the standby mode and that the time and date are set.



## 16. Applications

---

### ■ Games and applications

Your phone software may include some games and Java applications specially designed for this Nokia phone.



#### Launching a game or an application

Select *Menu* > *Applications* > *Games* > *Select game* or *Collection* > *Select application*. Scroll to a game or an application, and select *Open*.

#### Game and application downloads

Your phone supports J2ME Java applications. Make sure that the application is compatible with your phone before downloading it.

Select *Menu* > *Applications*, then *Games* > *Game downloads* or *Collection* > *App. downloads*. The list of available bookmarks is shown. Select *More bookmarks* to access the list of bookmarks in the *Network services* menu. See "Bookmarks" on page 80 .

Select a bookmark to connect to the desired service. For the availability of different services, pricing, and tariffs, contact your service provider.



**Important:** Only install and use applications from sources that offer adequate security and protection against harmful software.

Downloaded applications may be saved in the *Games* menu instead of the *Applications* menu.

#### Game settings

Select *Menu* > *Applications* > *Options* > *App. settings* to set sounds, lights, and shakes for games.

#### Memory status for games and applications

To view the amount of memory available for game and application installations (third shared memory), select *Menu* > *Applications* > *Games* or *Collection* > *Memory*.

## Applications

### ■ Calculator

The calculator in your phone adds, subtracts, multiplies, divides, calculates the square and the square root, and converts currency values.

1. Select *Menu* > *Applications* > *Extras* > *Calculator*.
2. When 0 is displayed on the screen, enter the first number in the calculation.  
Press # for a decimal point.
3. Select *Options* > *Add*, *Subtract*, *Multiply*, *Divide*, *Square*, *Square root*, or *Change sign*.
4. Enter the second number.
5. To get the answer, select *Equals*. Or to start a new calculation, press and hold *Clear*.

This calculator has a limited accuracy and rounding errors may occur, especially in long divisions.

### Performing a currency conversion

1. Select *Menu* > *Applications* > *Extras* > *Calculator*.
2. To save the exchange rate, select *Options* > *Exchange rate*.
3. Select either of the displayed options. Enter the exchange rate, press # for a decimal point, and select *OK*.  
The exchange rate remains in the memory until you replace it with another one.
4. To perform the currency conversion, enter the amount to be converted, and select *Options* > *To home* or *To foreign*.

### ■ Countdown timer

Select *Menu* > *Applications* > *Extras* > *Countdown timer*. Enter the alarm time in hours, minutes, and seconds, and select *OK*. You can write your own text to be displayed when the time expires, and select *Start* to start the countdown timer.

To change the countdown time, select *Change time*; or to stop the timer, select *Stop timer*.

If the alarm time is reached when the phone is in the standby mode, the phone sounds a tone and flashes the note text if it is set; otherwise, it flashes the text *Countdown completed*.

To stop the alarm, press any key. If no key is pressed, the alarm automatically stops within 30 seconds. To stop the alarm and delete the note text, select *Exit*.

## ■ Stopwatch

You can use the stopwatch to measure time, take intermediate times, or take lap times.

### Time observation and time splitting

Select *Menu* > *Applications* > *Extras* > *Stopwatch* > *Split timing*. Select *Start* to start the time observation. Select *Split* every time you want to take an intermediate time; the intermediate times are listed below the running time on the display. Select *Stop* to stop the time observation. To save the times, select *Save*. Select *Options*, and you can start the time observation again or reset the times without saving.

### Lap times

Select *Menu* > *Applications* > *Extras* > *Stopwatch* > *Lap timing*. Select *Start* to start the time observation and *Lap* to take a lap time. Select *Stop* to stop the lap timing. To save the times, select *Save* and enter a name. Or select *Options*, and you can save or reset the lap times.

### Phone features while timing

If you have already started the stopwatch and want to use other phone features while the stopwatch continues to run, simply press End to return to the standby mode. To return to the stopwatch, select *Menu* > *Applications* > *Extras* > *Stopwatch* > *Continue*.

Using the stopwatch or allowing it to run in the background when using other features increases the demand on battery power and reduces battery life.

### Viewing and deleting times

Select *Menu* > *Applications* > *Extras* > *Stopwatch*.

## Applications

If the stopwatch is not reset, you can select *Show last time* to view the most recent measured time. Select *View times*, and you can select from a list of names or final times of the time sets.

To delete the saved times, select *Delete times*. Select *Delete all > Yes* or select *One by one*. Scroll to the times you want to delete, and select *Delete > Yes*.

## ■ Wallet

In *Wallet* you can save personal information such as credit card numbers and addresses. The data saved in the wallet can easily be retrieved to automatically fill in data fields when making purchases while browsing, as long as the service supports wallet functionality. You can also save access codes to mobile services that request a user name and password.

If you have tried to access or have accessed confidential information requiring passwords, empty the cache after each use. To empty the cache, see "Cache memory" on page 82 .

### Set wallet code

The data in the wallet is protected with a wallet code that you can define when you access the wallet for the first time. At *Create wallet code*;, enter the code, and select *OK* to confirm it. At *Verify wallet code*;, enter the code again, and select *OK*.

### Delete wallet content

If you want to delete all the content of the wallet along with the wallet code, enter *\*#7370925538#* in the standby mode. You also need the phone security code (see "Access codes" on page 28 ).

### Use the wallet

To set up your personal information, use the wallet menu. To use the content of the wallet in a mobile service, access the wallet through the browser (see "Services" on page 78 ).

To use the wallet feature, select *Menu > Applications > Organizer > Wallet*. Enter your wallet code, select *OK* and select one of the following:

*Wallet profiles*—When you have saved your personal card details, you can combine them together into a wallet profile. You can use the profile to retrieve wallet data from different cards while browsing.

## Applications

*Cards*—Use this option to create and save *Payment cards*, *Loyalty cards*, *Access cards*, *User info cards*, or *Address cards*. For availability of receiving card information as configuration settings, contact the card issuer or your service provider.

*Tickets*—Save notifications for e-tickets you have bought through a mobile service.

*Receipts*—Save mobile purchase receipts.

*Personal notes*—Save personal information, such as account numbers, passwords, codes, or notations. Personal notes are protected with the wallet PIN code. When viewing a note, select *Options* and *Send via text msg.* to copy the note as a text message; *Copy to calendar* to copy the note to the calendar as a memo; *Use detail* to extract numbers, e-mail addresses, and web addresses from a note; and *Delete* to delete the note you are viewing.

*Settings*—Use this option to change wallet settings.

## 17. Services



Your phone has a browser that you can use to access various mobile Internet services.

Check the availability of these services, pricing, and tariffs with your service provider.

With the browser you can view the services that use Wireless Mark-Up Language (WML) or extensible HyperText Mark-up Language (XHTML) on their pages. Appearance may vary due to screen size. You may not be able to view all the details of the Internet pages.

### ■ Access and use services

1. Save the service settings that are required to access the service that you want to use. See "Set up the phone to access a service" on page 78 .
2. Make a connection to the given service. See "Connecting to a service" on page 78 .
3. Start browsing the pages of the service. See "Browse the pages of a service" on page 79 .
4. Once you are finished browsing, end the connection to the service. See "Disconnect from a service" on page 80 .

### Set up the phone to access a service

Your phone may already have some service settings stored. Additional settings may be received as a configuration message from the service provider that offers the service you want to use. For more information and for the appropriate settings, contact your service provider. See also "Configuration settings" on page 64 .

### Connecting to a service



Make sure that the service settings of the service you want to use are activated. To activate the settings, select *Menu* > *Network services* > *Settings* > *Configuration settings* > *Configuration* and select the configuration set you want to activate.

Connect to the service by one of the following methods:

- Open the homepage of the service provider: select *Menu* > *Network services* > *Home*, or in the standby mode, press and hold the *0* key.
- Open a bookmark of the service: select *Menu* > *Network services* > *Bookmarks* and select a bookmark. If the bookmark does not work with the current active service settings, activate another set of service settings and try again.
- Access the last URL: select *Menu* > *Network services* > *Last web addr.*
- Enter the address of the service: select *Menu* > *Network services* > *Go to address*. Enter the address of the service, and select *OK*.

### **Browse the pages of a service**

After you have connected to the service, you can start browsing its pages. The function of the phone keys may vary in different services. Follow the text guides on the phone display. For more information, contact your service provider.

If *GPRS* is selected as the data bearer, the indicator  is shown on the top left of the display during browsing. If you receive a call or a text message, or make a call during a GPRS connection, the indicator  will be shown on the top left of the display to indicate that the GPRS connection is suspended (on hold). After a call, for example, the phone tries to reconnect the GPRS connection. See also "GPRS and EGPRS" on page 88 .

If you have tried to access or have accessed confidential information requiring passwords, empty the cache after each use. To empty the cache, see "Cache memory" on page 82 .

### **Phone keys while browsing**

- Use any of the scroll keys to browse through the page.
- To select a highlighted item, press *Call*, or select *Options* to select the option for opening the link.
- To enter letters and numbers, press the keys *1–9*. To enter special characters, press *\**.

### **Direct calling**

While browsing, you can make a voice call, send touch tones while a voice call is in progress, and save a name and a phone number from a page.

## Services

### Disconnect from a service

To quit browsing and end the connection, select *Options* > *Quit*. When *Quit browsing?* is displayed, select *Yes*.

Press End twice, or press and hold End.

### Appearance settings of the browser

While browsing, select *Options* > *Other options* > *Appear. settings*; or in the standby mode, select *Menu* > *Network services* > *Settings* > *Appearance settings* and one of the following:

*Text wrapping*—Select *On*, and the text continues on the next line. If you select *Off*, the text will be abbreviated.

*Font size*—Select a font size.

*Show images*—Select *No*, and any pictures appearing on the page are not shown.

*Alerts*—Select *Alert for unsecure connection* and *Yes* to set the phone to alert when a secure connection changes to an insecure one during browsing. Select *Alert for unsecure items* and *Yes* to set the phone to alert when a secure page contains an insecure item. These alerts do not guarantee a secure connection. For more information, see "Browser security" on page 82 .

*Character encoding*—Select the character set that the phone uses to show browser pages that do not include that information, or select whether to always use UTF-8 encoding when sending a Web address to a compatible phone.

### Cookies

A cookie is data that a site saves in the cache memory of the browser, (for example, your user information or your browsing preferences). Cookies will be saved until you clear the cache memory. See "Cache memory" on page 82 .

While browsing, select *Options* > *Other options* > *Security* > *Cookie settings*; or in the standby mode, select *Menu* > *Network services* > *Settings* > *Security settings* > *Cookies*. Select *Allow* or *Reject* to allow cookies or prevent the phone from receiving them.

### Bookmarks

You can save page addresses as bookmarks in the phone memory.

1. While browsing, select *Options* > *Bookmarks*; or in the standby mode, select *Menu* > *Network services* > *Bookmarks*.



2. Select the bookmark that you want to use and press [Select](#) to make a connection to the page associated with the bookmark.

Select [Options](#) to view the title and the address of the selected bookmark, edit or delete the selected bookmark, send it directly to another phone as a bookmark or text message, or create a new bookmark.

Your device may have some bookmarks loaded for sites not affiliated with Nokia. Nokia does not warrant or endorse these sites. If you choose to access them, you should take the same precautions for security or content as you would with any Internet site.

### Receive a bookmark

When you receive a bookmark, *1 bookmark received* is displayed. Select [Show](#) to view the bookmark. To save the bookmark, select [Save](#). Select [Options](#) > [View](#) to see the details or [Delete](#) to discard it.

### Download

To download more tones, graphics, games, videos, themes, or applications to your phone (network service), select the type of download to receive.



Only install applications from sources that offer adequate protection against harmful software.

For the availability of different services, pricing, and tariffs, contact your service provider.

### Service inbox

The phone is able to receive service messages (pushed messages) sent by your service provider (network service). Service messages are, for example, notifications of news headlines, and they may contain a text message or an address of a service.

When you receive a service message in the standby mode, select [Show](#) to access the message in the [Service inbox](#). If you select [Exit](#), the message is moved to the [Service inbox](#). To access the [Service inbox](#) later, select [Menu](#) > [Network services](#) > [Service inbox](#).

To access the [Service inbox](#) while browsing, select [Options](#) > [Other options](#) > [Service inbox](#). Scroll to the message that you want, and select [Retrieve](#) to activate the browser and download the marked content. To display detailed

## Services

information on a service notification or to delete it, select [Options](#) > [Details](#) or [Delete](#), respectively.

### Service inbox settings

Select [Menu](#) > [Network services](#) > [Settings](#) > [Service inbox settings](#) and one of the following:

[Service messages](#)—Select [On](#) or [Off](#) to set the phone to receive or not receive service messages.

[Message filter](#)—Select [Message filter on](#) to set the phone to receive service messages only from content authors approved by the service provider. To view the list of the approved content authors, select [Trusted channels](#).

[Automatic connection](#)—If you set the phone to receive service messages and select [On](#), the phone will automatically activate the browser from the standby mode when the phone receives a service message. If you select [Off](#), the phone will activate the browser only after you have selected [Retrieve](#) when the phone receives a service message.

### Cache memory

The information or services that you access are stored in the cache of your phone. A cache is a buffer memory, which is used to store data temporarily. To empty the cache while browsing, select [Options](#) > [Other options](#) > [Clear the cache](#); or in the standby mode, select [Menu](#) > [Network services](#) > [Clear the cache](#).

### Browser security

Security features may be required for some services, such as banking services or online shopping. For such connections, you need security certificates and possibly a security module, which may be available on your SIM card. For more information, contact your service provider.

### Security module

The security module can contain certificates as well as private and public keys. The purpose of the security module is to improve security services for applications requiring browser connection, and it allows you to use a digital signature. The certificates are saved in the security module by the service provider. See "Access codes" on page 28 .

Select [Menu](#) > [Network services](#) > [Settings](#) > [Security settings](#) > [Security module settings](#) and one of the following:

**Security module details**—Show the security module title, status, manufacturer, and serial number.

**Module PIN request**—Set the phone to request the module PIN when using services provided by the security module. Enter the code, and select *On*. To disable the module PIN request, select *Off*.

**Change module PIN**—Change the module PIN, if allowed by the security module. Enter the current module PIN code; then enter the new code twice.

**Change signing PIN**—Select the signing PIN that you want to change. Enter the current PIN code, then enter the new code twice.

## Certificates

There are three kinds of certificates:

**Server certificates**—Used by the phone to create a connection with improved security to the content server. The phone receives the server certificate from the service provider before the connection is established, and its validity is checked using the authority certificates saved in the phone. Server certificates are not saved.

The security indicator  is displayed during a connection if the data transmission between the phone and the content server is encrypted.

The security icon does not indicate that the data transmission between the gateway and the content server (or place where the requested resource is stored) is secure. The service provider secures the data transmission between the gateway and the content server.

**Authority certificates**—Used by some services, such as banking services, for checking the validity of other certificates. Authority certificates can either be saved in the security module by the service provider, or they can be downloaded from the network if the service supports the use of authority certificates.

**User certificates**—Issued to users by a Certifying Authority. User certificates are required (for example, to create a digital signature), and they associate the user with a specific private key on a security module.



**Important:** Even if the use of certificates makes the risks involved in remote connections and software installation considerably smaller, they must be used correctly in order to benefit from increased security. The existence of a certificate does not offer any protection by itself; the certificate manager must contain correct, authentic, or trusted certificates for increased security to be available. Certificates have a restricted lifetime. If *Certificate invalid according to phone's date* or

## S e r v i c e s

*User certificate not valid yet* is shown even if the certificate should be valid, check that the current date and time in your device are correct.

Before changing any certificate settings, you must make sure that you really trust the owner of the certificate and that the certificate really belongs to the listed owner.

### Digital signature

You can make digital signatures with your phone if your SIM card has a security module. The signature can be traced back to you by the private key on the security module and the user certificate that was used to perform the signature. Using the digital signature can be the same as signing your name to a paper bill, contract, or other document. See "Security module" on page 82 .

To make a digital signature, select a link on a page, such as the title of the book that you want to buy and its price. The text to sign (possibly including amount, date, etc.) will be shown.

Check that the header text is *Read* and that the digital signature icon  is shown.



**Note:** If the digital signature icon does not appear, there is a security breach, and you should not enter any personal data such as your signing PIN.

To sign the text, read all of the text first; and then you can select *Sign*.

The text may not fit within a single screen. Therefore, make sure to scroll through and read all of the text before signing.

Select the user certificate you want to use. Enter the signing PIN, and select *OK*. The digital signature icon will disappear, and the service may display a confirmation of your purchase.

## 18. Connectivity

---

You can define the settings for Bluetooth connections, Infrared connections and GPRS dial-up connections.

### ■ Bluetooth connectivity

Bluetooth connectivity enables cost-free wireless connections between electronic devices within a maximum range of 30 feet. A Bluetooth connection can be used to send and receive images, texts, gallery files, voice recordings, video clips, notes, business cards, and calendar notes. It can also be used to connect wirelessly to products that use Bluetooth wireless technology, such as computers. You can synchronize your phone and your PC using a Bluetooth connection.

Since devices with Bluetooth connectivity communicate using radio waves, your phone and the other device do not need to be in direct line-of-sight. The two devices only need to be within a maximum of 30 feet (10 meters) of each other, although the connection can be subject to interference from obstructions such as walls or from other electronic devices. The Bluetooth application consumes the battery and reduces the operating time of the phone. Take this into account when performing other operations with your phone. There may be restrictions on using devices with Bluetooth connectivity. Check with your local authorities. Your phone supports Bluetooth specification 1.1 and the following profiles:

- SIM access profile
- Object push profile  
File transfer profile  
Dial-up networking profile  
Headset profile  
Hands-free profile  
Generic access profile  
Serial port profile  
Generic access exchange profile

For compatibility between your phone and another device with Bluetooth connectivity, consult the device documentation and your Nokia dealer.

### Set up a Bluetooth connection

1. Select *Menu* > *Settings* > *Connectivity* > *Bluetooth*.
2. To activate the Bluetooth function, select *Bluetooth* > *On*.

The active Bluetooth connection is indicated by at the top of the display.

## Connectivity

3. Select *Search for audio enhancements* to search for compatible devices with Bluetooth connectivity.  
The list of found devices appears in the display.
4. Select the desired device
5. If required, enter the Bluetooth passcode of the device to pair with the device.  
For information on the Bluetooth passcode, see "Pairing" on page 86 .  
Your phone connects to the device. You can start data transfer.
6. To view the device you are connected to, select *Active device*.
7. To deactivate Bluetooth, select *Bluetooth > Off*.

## Pairing

You can set up a permanent pairing (association) between your phone and another device with Bluetooth connectivity. Some devices may require pairing before data transfer can take place.

To pair with a device, you and the owner of the other device must agree on a passcode of 1–16 numeric characters. The first time you try to connect the devices, you must each enter the same passcode. Once the devices are paired, you will not need to use the passcode again, so there is no need to remember it. Paired devices are placed in your paired device list. You can view the list even when Bluetooth is not active or when the devices in the list are not available for connection. To view the paired device list, do the following:

1. From the menus, select *Settings > Connectivity > Bluetooth > Paired devices*.
2. Scroll to the desired device, and select *Options* and one of the following:
  - Assign short name*—Give a nickname (visible to you only) to the selected device.
  - Auto-conn. with- out confirmation*—Select *Yes* if you want the phone to connect to the selected device automatically or *No* if you want the phone to ask for your permission first.
  - Delete pairing*—Delete the pairing to the selected device.
  - Pair new device*—Search for active devices with Bluetooth connectivity within range, scroll to the desired device, and select *Pair* to establish pairing with that device.

## Settings

You can define how your phone is shown to other devices with Bluetooth connectivity.

Select *Menu* > *Settings* > *Bluetooth* > *Connectivity* > *Bluetooth settings* and one of the following:

*My phone's visibility*—Select *Shown to all* to show the phone to all other devices with Bluetooth connectivity or *Hidden* to show the phone only to the paired devices.

*My phone's name*—Change your phone name that is seen by other users.

## Send data

Instead of using the *Settings* menu, you can use other phone menus to send various types of data to other devices with Bluetooth connectivity. You can send a video clip from the *Video clips* folder of the *Gallery* menu. See the appropriate sections of the user guide for information about sending different types of data.

## Receive a data transfer

When a Bluetooth connection is active in your phone, you can receive notes, business cards, video clips, and other types of data transfers from another device with Bluetooth connectivity. When you receive a data transfer, an alarm sounds, and a message appears in the start screen.

- To view the transferred item immediately, select *Show*.
- To save the item for later viewing, select *Exit*.

Depending on the nature of the item, it is saved in the appropriate menu in your phone. For example, a business card would be saved in *Contacts*, and a calendar note would be saved in *Calendar*.

## **■ Infrared**

The phone has an IR port that you can use for connecting your phone to another IrDA compliant device. You can send or receive data such as business cards and calendar notes to or from a compatible phone or data device, such as a computer. Bluetooth connections and IR connections cannot be active at the same time.

Do not point the IR (infrared) beam at anyone's eye or allow it to interfere with other IR devices. This device is a class 1 laser product.

## Connectivity

### Send and receive data

- Ensure that the IR ports of the sending and receiving devices are pointing at each other and that there are no obstructions between the devices.
- To activate the IR port of your phone, select *Menu > Settings > Connectivity > Infrared*.
- The user of the sending phone selects the desired IR function to start data transfer.

If the data transfer is not started within 2 minutes after the activation of the IR port, the connection is cancelled and has to be started again.

### Connecting icon

When  blinks continuously, the IR connection has been activated and your phone is ready to send or receive data using its IR port.

The IR connector deactivates automatically.

### ■ GPRS and EGPRS

GPRS (general packet radio service) is a network service that allows mobile phones to be used for sending and receiving data over an Internet protocol (IP)-based network.

EGPRS (enhanced GPRS), also known as EDGE (enhanced data rates for global evolution), is similar to GPRS. For more information on the availability of EGPRS and data transfer speed, contact your service provider.

When you have selected *GPRS* as a data bearer, the phone uses EGPRS instead of GPRS if it is available in the network. You cannot select between EGPRS and GPRS in your phone, but for some applications, you may be able to select either *GPRS* or *GSM data* (CSD—circuit switched data) as the data bearer. The data bearer is part of the preferred access point and can be changed in *Configuration settings* (see "Configuration settings" on page 64).

The applications that may use GPRS are MMS, instant messaging, browsing sessions, e-mail, remote SyncML, Java application downloading, and the PC dial-up (for example, Internet and e-mail).

Before you can use GPRS technology, contact your service provider for availability of and subscription to the GPRS service and save the GPRS settings for each of the applications used over GPRS.



### **GPRS connection**

Select *Menu > Settings > Connectivity > GPRS > GPRS connection* and one of the following:

*Always online*—Set the phone to automatically register to a GPRS network when you switch the phone on.

*When needed*—Set the phone to establish GPRS registration and connection when an application using GPRS needs it and to close the connection when you end the application.

### **GPRS modem settings**

You can connect the phone by a data cable connection to a compatible PC and use the phone as a modem to enable GPRS connectivity from the PC.

To define the settings for GPRS connections from your PC, select *Menu > Settings > Connectivity > GPRS > GPRS modem settings*, and one of the following:

*Active access point*—Activate the access point that you want to use.

*Edit active access point*—Change the access point settings:

- *Alias for access point*—Enter a name for the activated access point, and select *OK*.
- *GPRS access point*—Enter the access point name (APN) to establish a connection to a GPRS network, and select *OK*. Contact your service provider for the APN.

You can also set the GPRS dial-up service settings (access point name) on your PC using the Nokia Modem Options software, see "PC Suite" on page 90 . If you have set the settings both on your PC and on your phone, then the PC settings will be used.

## 19. PC connectivity

---

You can send and receive e-mail and access the Internet when you use Bluetooth, Infrared, or a data cable to connect your phone to a compatible PC. You can use a variety of PC connectivity and data communications applications with your phone. With PC Suite you can synchronize contacts, calendar, and notes between your phone and the compatible PC or a remote Internet server (network service).

You may find more information and downloadable files, including PC Suite, in the support area on the Nokia website [www.nokia.com](http://www.nokia.com).

Copyright protections may prevent some images, ringing tones, and other content from being copied, modified, transferred, or forwarded.

### ■ PC Suite

PC Suite allows you to transfer and synchronize information between your phone and your PC. With PC Suite, you can edit contacts in your phone, install J2ME Java applications (such as games and dictionaries) from a compatible PC to the phone, and backup and restore personal data between your phone and a compatible PC. To see the comprehensive features offered by PC Suite, you can download the application from the Nokia website [www.nokia.com](http://www.nokia.com).

### ■ GPRS, EGPRS, HSCSD, and CSD

You can use the following data services with your phone:

- GPRS (general packet radio service)
- EGPRS (enhanced GPRS) (See "GPRS and EGPRS" on page 88.)
- HSCSD (high speed circuit switched data)
- CSD (circuit switched data—or GSM data)

For availability and subscription to data services, contact your service provider.

The use of HSCSD services consumes the phone battery faster than normal voice or data calls. You may need to connect the phone to a charger for the duration of the data transfer.

## ■ Data communication applications

For information on using a data communication application, refer to the documentation provided with it.

Making or answering phone calls during a computer connection is not recommended because it might disrupt the operation.

For better performance during data calls, place the phone on a stationary surface with the keypad facing downward. Do not move the phone by holding it in your hand during a data call.

## 20. Reference information

---

### ■ Battery information

#### Charging and discharging

Your device is powered by a rechargeable battery. The full performance of a new battery is achieved only after two or three complete charge and discharge cycles. The battery can be charged and discharged hundreds of times but it will eventually wear out. When the talk and standby times are noticeably shorter than normal, buy a new battery. Use only Nokia approved batteries, and recharge your battery only with Nokia approved chargers designated for this device.

Check the model number of any charger before use with this device. This device is intended for use when supplied with power from the ACP-12 charger.

Unplug the charger from the electrical plug and the device when not in use. Do not leave the battery connected to a charger. Overcharging may shorten its lifetime. If left unused, a fully charged battery will lose its charge over time. Temperature extremes can affect the ability of your battery to charge.

Use the battery only for its intended purpose. Never use any charger or battery that is damaged.

Do not short-circuit the battery. Accidental short-circuiting can occur when a metallic object such as a coin, clip, or pen causes direct connection of the positive (+) and negative (-) terminals of the battery. (These look like metal strips on the battery.) This might happen, for example, when you carry a spare battery in your pocket or purse. Short-circuiting the terminals may damage the battery or the connecting object.

Leaving the battery in hot or cold places, such as in a closed car in summer or winter conditions, will reduce the capacity and lifetime of the battery. Always try to keep the battery between 59°F and 77°F (15°C and 25°C). A device with a hot or cold battery may not work temporarily, even when the battery is fully charged. Battery performance is particularly limited in temperatures well below freezing.

Do not dispose of batteries in a fire! Dispose of batteries according to local regulations. Please recycle when possible. Do not dispose as household waste.

### ■ Enhancements

A few practical rules about enhancements:

## Reference information

- Keep all enhancements out of the reach of small children.
- When you disconnect the power cord of any enhancement, grasp and pull the plug, not the cord.
- Check regularly that enhancements installed in a vehicle are mounted and are operating properly.
- Installation of any complex car enhancements must be made by qualified personnel only.
- For enhancement warranty information, see [www.nokiausa.com/support/warranty](http://www.nokiausa.com/support/warranty).

If you want to enhance phone functionality, a range of enhancements is available for you. You can select any of these items to help accommodate your specific communication needs. For availability of these and other enhancements, contact your dealer.



### Audio

- Wireless Headset (HDW-3)
- Wireless Clip-on Headset (HS-3W) Wireless Boom Headset (HS-4W) Boom Headset (HDB-4) Headset (HS-5) Retractable Headset (HS-10) Phone Adapter (HDA-10) Inductive Loopset (LPS-4)

### Car

- Wireless Car Kit (CARK112)
- Wireless Car Kit (CK-1W) Car Installation Kit (CARK 126)

### Imaging

- Nokia Observation Camera
- Image Frames (SU-4/7) Image Viewer (SU-2)

### Messaging

- Digital Pen (SU-1B)

## Reference information

### Data

- Data Cable (CA-42)
- Desktop Stand (DCV-14)

### Power

- Battery, 850 mAh, Li-ion (BL-5C)
- Retractable Charger (AC-1)
- Travel Charger (ACP-12)

### Patent information

Manufactured or sold under one of many of the following US patents. Asterisk (\*) indicates design patents pending.

RE 32,580	4558302	4868846	4945633	4969192	5001372
5101175	5151946	5173927	5212834	5230091	5241583
5311151	5317283	5331638	5335362	5353328	5371481
5378935	5384782	5396657	5400949	5416435	5442521
5446364	5479476	5526366	5553125	5557639	5565821
5570369	5581244	5600708	5625274	5677620	5692032
5729541	5760568	5794142	5802465	5809413	5818437
5827082	5839101	5844884	5845219	5870683	5884103
5889770	5907823	5912570	5914690	5914796	5917868
5920826	5953541	5956332	5956625	5956633	5966378
5977887	5987137	5991857	6006114	6011554	6011853
6014551	6014573	6026161	6035189	6038238	6043760
6047196	6049796	6050415	6055439	6060193	6069923
6072787	6081732	6084920	6084962	6094587	6097964
6105784	6112099	6115617	6119180	6121846	6128509
6138091	6140966	6144243	6144676	6148209	6151485
6151507	6163609	6164547	6167248	6185295	6188909
6249584	6259312	6266330	6272361	6282436	6292668

#### Reference information

6295286	6311054	6314166	6324389	6324412	6347218
6363259	6370362	6370389	6377820	6381468	6392660
6400958	6453179	6463278	6470470	6487397	6522670
6198928	4969192	5266782	5390223	5444816	5487084
5640395	5664053	5699482	5701392	5722074	5754976
5805301	5835889	5857151	5859843	5862178	5898925
5930233	5946651	5960354	5960389	5963901	6005857
6011971	6031827	6118775	6128322	6137789	6167248
6170073	6178535	6195338	6199035	6240076	6266321
6285888	6356759	6377803	6430163	6438370	6456237

#### Care and maintenance

Your device is a product of superior design and craftsmanship and should be treated with care. The suggestions below will help you protect your warranty coverage.

- Keep the device dry. Precipitation, humidity, and all types of liquids or moisture can contain minerals that will corrode electronic circuits. If your device does get wet, remove the battery and allow the device to dry completely before replacing it.
- Do not use or store the device in dusty, dirty areas. Its moving parts and electronic components can be damaged.
- Do not store the device in hot areas. High temperatures can shorten the life of electronic devices, damage batteries, and warp or melt certain plastics.
- Do not store the device in cold areas. When the device returns to its normal temperature, moisture can form inside the device and damage electronic circuit boards.
- Do not attempt to open the device other than as instructed in this guide.
- Do not drop, knock, or shake the device. Rough handling can break internal circuit boards and fine mechanics.
- Do not use harsh chemicals, cleaning solvents, or strong detergents to clean the device.

#### Reference information

- Do not paint the device. Paint can clog the moving parts and prevent proper operation.
- Use a soft, clean, dry cloth to clean any lenses (such as camera, proximity sensor, and light sensor lenses).
- Use only the supplied or an approved replacement antenna. Unauthorized antennas, modifications, or attachments could damage the device and may violate regulations governing radio devices.

All of the above suggestions apply equally to your device, battery, charger, or any enhancement. If any device is not working properly, take it to the nearest authorized service facility for service.

### ■ Additional safety information

#### Operating environment

Remember to follow any special regulations in force in any area and always switch off your device when its use is prohibited or when it may cause interference or danger. Use the device only in its normal operating positions. This device meets RF exposure guidelines when used either in the normal use position against the ear or when positioned at least 7/8 inch (2.2 cm) away from the body. When a carry case, belt clip, or holder is used for body-worn operation, it should not contain metal and should position the device at least 7/8 inch (2.2 cm) away from your body.

In order to transmit data files or messages, this device requires a quality connection to the network. In some cases, transmission of data files or messages may be delayed until such a connection is available. Ensure the above separation distance instructions are followed until the transmission is completed.

#### Medical devices

Operation of any radio transmitting equipment, including wireless phones, may interfere with the functionality of inadequately protected medical devices. Consult a physician or the manufacturer of the medical device to determine if they are adequately shielded from external RF energy or if you have any questions. Switch off your phone in health care facilities when any regulations posted in these areas instruct you to do so. Hospitals or health care facilities may be using equipment that could be sensitive to external RF energy.



## Reference information

### PACEMAKERS

Pacemaker manufacturers recommend that a minimum separation of 6 inches (15.3 cm) be maintained between a wireless phone and a pacemaker to avoid potential interference with the pacemaker. These recommendations are consistent with the independent research by and recommendations of Wireless Technology Research. To minimize the potential for interference, persons with pacemakers should

- Always keep the device more than 6 inches (15.3 cm) from their pacemaker when the device is switched on
- Not carry the device in a breast pocket
- Hold the device to the ear opposite the pacemaker to minimize the potential for interference

If you have any reason to suspect that interference is taking place, switch off your device immediately.

### HEARING AID

Some digital wireless devices may interfere with some hearing aids. If interference occurs, consult your service provider.

### Vehicles

RF signals may affect improperly installed or inadequately shielded electronic systems in motor vehicles such as electronic fuel injection systems, electronic antiskid (antilock) braking systems, electronic speed control systems, air bag systems. For more information, check with the manufacturer or its representative of your vehicle or any equipment that has been added.

Only qualified personnel should service the device, or install the device in a vehicle. Faulty installation or service may be dangerous and may invalidate any warranty that may apply to the device. Check regularly that all wireless device equipment in your vehicle is mounted and operating properly. Do not store or carry flammable liquids, gases, or explosive materials in the same compartment as the device, its parts, or enhancements. For vehicles equipped with an air bag, remember that an air bags inflate with great force. Do not place objects, including installed or portable wireless equipment in the area over the air bag or in the air bag deployment area. If in-vehicle wireless equipment is improperly installed and the air bag inflates, serious injury could result.

Using your device while flying in aircraft is prohibited. Switch off your device before boarding an aircraft. The use of wireless teledevices in an aircraft may be

## Reference information

dangerous to the operation of the aircraft, disrupt the wireless telephone network, and may be illegal.

### **Potentially explosive environments**

Switch off your device when in any area with a potentially explosive atmosphere and obey all signs and instructions. Potentially explosive atmospheres include areas where you would normally be advised to turn off your vehicle engine. Sparks in such areas could cause an explosion or fire resulting in bodily injury or even death. Switch off the device at refuelling points such as near gas pumps at service stations. Observe restrictions on the use of radio equipment in fuel depots, storage, and distribution areas, chemical plants or where blasting operations are in progress. Areas with a potentially explosive atmosphere are often but not always clearly marked. They include below deck on boats, chemical transfer or storage facilities, vehicles using liquefied petroleum gas (such as propane or butane), and areas where the air contains chemicals or particles such as grain, dust or metal powders.

Failure to observe these instructions may lead to suspension or denial of telephone services to the offender, legal action, or both.

### **EMERGENCY CALLS**



**Important:** Wireless phones, including this phone, operate using radio signals, wireless networks, landline networks, and user-programmed functions. Because of this, connections in all conditions cannot be guaranteed. You should never rely solely on any wireless phone for essential communications like medical emergencies.

To make an emergency call:

1. If the phone is not on, switch it on. Check for adequate signal strength. Some networks may require that a valid SIM card is properly inserted in the phone.
2. Press End as many times as needed to clear the display and ready the phone for calls.
3. Enter the official emergency number for your present location. Emergency numbers vary by location.
4. Press Call.

If certain features are in use, you may first need to turn those features off before you can make an emergency call. If the device is in offline or flight mode you must change the profile to activate the phone function before you can make an

## Reference information

emergency call. Consult this guide or your service provider. When making an emergency call, give all the necessary information as accurately as possible. Your wireless phone may be the only means of communication at the scene of an accident. Do not end the call until given permission to do so.

### **Certification Information [SAR]**

THE NOKIA 6822b DEVICE MEETS THE GOVERNMENT'S REQUIREMENTS FOR EXPOSURE TO RADIO WAVES.

Your mobile device is a radio transmitter and receiver. It is designed and manufactured not to exceed the limits for exposure to radio frequency [RF] energy recommended by international guidelines [ICNIRP]. These limits establish permitted levels of RF energy for the general population. The guidelines are based on standards that were developed by independent scientific organisations through periodic and thorough evaluation of scientific studies. The standards and guidelines include a substantial safety margin designed to assure the safety of the public, regardless of age and health and to account for any variations in measurements.

The exposure guidelines for mobile devices employs a unit of measurement known as the Specific Absorption Rate, or SAR. The SAR limit stated in the international guidelines is 2.0 W/kg\* averaged over ten grams of tissue. Tests for SAR are conducted using standard operating positions with the device transmitting at its highest certified power level in all tested frequency bands. The actual SAR level of an operating device can be well below the maximum value because the device is designed to use only the power required to reach the network. That amount changes depending on a number of factors such as how close you are to a network base station. The highest SAR value when tested according to international testing procedures for use at the ear for device type **PYARM-68** is 0.97 W/kg. Your phone's device type is listed on the label located under the battery.

SAR values may vary depending on national reporting and testing requirements and the network band. Use of device accessories and enhancements may result in different SAR values. Additional SAR information in other regions please look under product information at [www.nokia.com](http://www.nokia.com).

USA and Canada: The SAR limit of USA (FCC) and Canada (IC) is 1.6 W/kg averaged over one gram of tissue. Device type **PYARM-68** has also been tested against this SAR limit. The highest SAR value reported under this standard during product certification for use at the ear is 0.97 W/kg and when properly worn on the body is 1.01 W/kg. Information about this device can be found on the FCC's

## Reference information

website at <http://www.fcc.gov/oet/fccid> by searching the equipment authorization system using FCC ID PYARM-68

## ■ Technical information

**Dimensions**— 46.1 mm at hinges, 38 mm at bottom; length—106.1 mm; depth—21.6 mm at top, 17 mm at bottom

**Weight**—100 g with BL-5C 850 mAh semi fixed Li-ion Battery

**Size (volume)**—79 cm<sup>3</sup>

**Wireless networks**—Nokia 6822b: GSM 850, 1800, and 1900 networks

**Frequency range (Tx)**—GSM 850: 824–849 MHz (for RH-68) EGSM 900: 880–915 MHz (for RH-69) GSM 1800: 1710–1785 MHz (for RH-68 and RH-69) GSM 1900: 1850–1910 MHz (for RH-68 and RH-69)

**Frequency range (Rx)**—GSM 850: 869–894 MHz (for RH-68) EGSM 900: 925–960 MHz (for RH-69) GSM 1800: 1805–1865 MHz (for RH-68 and RH-69) GSM 1900: 1930–1990 MHz (for RH-68 and RH-69)

**Tx output power**—2 W (max)

**Number of channels**—299

**Memory size**—16-MB flash memory, approximately 2 MB available to user

**Battery voltage**—3.7 V dc

**Operating temperature**— (14 to +131°F) -10 to +55°C

---

■ **Appendix A Message from the CTIA (Cellular Telecommunications & Internet Association) to all users of mobile phones**

© 2001 Cellular Telecommunications & Internet Association. All Rights Reserved.  
1250 Connecticut Avenue, NW Suite 800, Washington, DC 20036. Phone: (202) 785-0081

**Safety is the most important call you will ever make.**

### **A Guide to Safe and Responsible Wireless Phone Use**

Tens of millions of people in the U.S. today take advantage of the unique combination of convenience, safety and value delivered by the wireless telephone. Quite simply, the wireless phone gives people the powerful ability to communicate by voice—almost anywhere, anytime—with the boss, with a client, with the kids, with emergency personnel or even with the police. Each year, Americans make billions of calls from their wireless phones, and the numbers are rapidly growing.

But an important responsibility accompanies those benefits, one that every wireless phone user must uphold. When driving a car, driving is your first responsibility. A wireless phone can be an invaluable tool, but good judgment must be exercised at all times while driving a motor vehicle—whether on the phone or not.

The basic lessons are ones we all learned as teenagers. Driving requires alertness, caution and courtesy. It requires a heavy dose of basic common sense—keep your head up, keep your eyes on the road, check your mirrors frequently and watch out for other drivers. It requires obeying all traffic signs and signals and staying within the speed limit. It means using seatbelts and requiring other passengers to do the same.

But with wireless phone use, driving safely means a little more. This brochure is a call to wireless phone users everywhere to make safety their first priority when behind the wheel of a car. Wireless telecommunications is keeping us in touch, simplifying our lives, protecting us in emergencies and providing opportunities to help others in need.

When it comes to the use of wireless phones, safety is your most important call.

**Wireless Phone "Safety Tips"**

Below are safety tips to follow while driving and using a wireless phone which should be easy to remember.

1. Get to know your wireless phone and its features such as speed dial and redial. Carefully read your instruction manual and learn to take advantage of valuable features most phones offer, including automatic redial and memory. Also, work to memorize the phone keypad so you can use the speed dial function without taking your attention off the road.
2. When available, use a hands free device. A number of hands free wireless phone accessories are readily available today. Whether you choose an installed mounted device for your wireless phone or a speaker phone accessory, take advantage of these devices if available to you.
3. Position your wireless phone within easy reach. Make sure you place your wireless phone within easy reach and where you can grab it without removing your eyes from the road. If you get an incoming call at an inconvenient time, if possible, let your voice mail answer it for you.
4. Suspend conversations during hazardous driving conditions or situations. Let the person you are speaking with know you are driving; if necessary, suspend the call in heavy traffic or hazardous weather conditions. Rain, sleet, snow and ice can be hazardous, but so is heavy traffic. As a driver, your first responsibility is to pay attention to the road.
5. Do not take notes or look up phone numbers while driving. If you are reading an address book or business card, or writing a "to do" list while driving a car, you are not watching where you are going. It's common sense. Don't get caught in a dangerous situation because you are reading or writing and not paying attention to the road or nearby vehicles.
6. Dial sensibly and assess the traffic; if possible, place calls when you are not moving or before pulling into traffic. Try to plan your calls before you begin your trip or attempt to coincide your calls with times you may be stopped at a stop sign, red light or otherwise stationary. But if you need to dial while driving, follow this simple tip—dial only a few numbers, check the road and your mirrors, then continue.
7. Do not engage in stressful or emotional conversations that may be distracting. Stressful or emotional conversations and driving do not mix—they are distracting and even dangerous when you are behind the wheel of a car. Make people you are talking with aware you are driving and if necessary, suspend conversations which have the potential to divert your attention from the road.

8. Use your wireless phone to call for help. Your wireless phone is one of the greatest tools you can own to protect yourself and your family in dangerous situations—with your phone at your side, help is only three numbers away. Dial 9-1-1 or other local emergency number in the case of fire, traffic accident, road hazard or medical emergency. Remember, it is a free call on your wireless phone!
9. Use your wireless phone to help others in emergencies. Your wireless phone provides you a perfect opportunity to be a "Good Samaritan" in your community. If you see an auto accident, crime in progress or other serious emergency where lives are in danger, call 9-1-1 or other local emergency number, as you would want others to do for you.
10. Call roadside assistance or a special wireless non-emergency assistance number when necessary. Certain situations you encounter while driving may require attention, but are not urgent enough to merit a call for emergency services. But you still can use your wireless phone to lend a hand. If you see a broken-down vehicle posing no serious hazard, a broken traffic signal, a minor traffic accident where no one appears injured or a vehicle you know to be stolen, call roadside assistance or other special non-emergency wireless number.

Careless, distracted individuals and people driving irresponsibly represent a hazard to everyone on the road. Since 1984, the Cellular Telecommunications Industry Association and the wireless industry have conducted educational outreach to inform wireless phone users of their responsibilities as safe drivers and good citizens. As we approach a new century, more and more of us will take advantage of the benefits of wireless telephones. And, as we take to the roads, we all have a responsibility to drive safely.

**The wireless industry reminds you to use your phone safely when driving.**

For more information, please call 1-888-901-SAFE.

For updates: <http://www.wow-com.com/consumer/issues/driving/articles.cfm?ID=85>

### ■ [Appendix B Message from the FDA \(U.S. Food and Drug Administration\) to all users of mobile phones](#)

©July 18, 2001 For updates: <http://www.fda.gov/cdrh/phones>

#### **Consumer Update on Wireless Phones – U.S. Food and Drug Administration**

1. Do wireless phones pose a health hazard?

The available scientific evidence does not show that any health problems are associated with using wireless phones. There is no proof, however, that wireless phones are absolutely safe. Wireless phones emit low levels of radiofrequency energy (RF) in the microwave range while being used. They also emit very low levels of RF when in the stand-by mode. Whereas high levels of RF can produce health effects (by heating tissue), exposure to low level RF that does not produce heating effects causes no known adverse health effects. Many studies of low level RF exposures have not found any biological effects. Some studies have suggested that some biological effects may occur, but such findings have not been confirmed by additional research. In some cases, other researchers have had difficulty in reproducing those studies, or in determining the reasons for inconsistent results.

**2. What is FDA's role concerning the safety of wireless phones?**

Under the law, FDA does not review the safety of radiation-emitting consumer products such as wireless phones before they can be sold, as it does with new drugs or medical devices. However, the agency has authority to take action if wireless phones are shown to emit radiofrequency energy (RF) at a level that is hazardous to the user. In such a case, FDA could require the manufacturers of wireless phones to notify users of the health hazard and to repair, replace or recall the phones so that the hazard no longer exists.

Although the existing scientific data do not justify FDA regulatory actions, FDA has urged the wireless phone industry to take a number of steps, including the following:

- Support needed research into possible biological effects of RF of the type emitted by wireless phones;
- Design wireless phones in a way that minimizes any RF exposure to the user that is not necessary for device function; and
- Cooperate in providing users of wireless phones with the best possible information on possible effects of wireless phone use on human health.

FDA belongs to an interagency working group of the federal agencies that have responsibility for different aspects of RF safety to ensure coordinated efforts at the federal level. The following agencies belong to this working group:

- National Institute for Occupational Safety and Health
- Environmental Protection Agency
- Federal Communications Commission
- Occupational Safety and Health Administration
- National Telecommunications and Information Administration



The National Institutes of Health participates in some interagency working group activities, as well.

FDA shares regulatory responsibilities for wireless phones with the Federal Communications Commission (FCC). All phones that are sold in the United States must comply with FCC safety guidelines that limit RF exposure. FCC relies on FDA and other health agencies for safety questions about wireless phones. FCC also regulates the base stations that the wireless phone networks rely upon. While these base stations operate at higher power than do the wireless phones themselves, the RF exposures that people get from these base stations are typically thousands of times lower than those they can get from wireless phones. Base stations are thus not the subject of the safety questions discussed in this document.

**3. What kinds of phones are the subject of this update?**

The term wireless phone refers here to hand-held wireless phones with built-in antennas, often called cell mobile or PCS phones. These types of wireless phones can expose the user to measurable radiofrequency energy (RF) because of the short distance between the phone and the user's head. These RF exposures are limited by Federal Communications Commission safety guidelines that were developed with the advice of FDA and other federal health and safety agencies. When the phone is located at greater distances from the user, the exposure to RF is drastically lower because a person's RF exposure decreases rapidly with increasing distance from the source. The so-called cordless phones; which have a base unit connected to the telephone wiring in a house, typically operate at far lower power levels, and thus produce RF exposures far below the FCC safety limits.

**4. What are the results of the research done already?**

The research done thus far has produced conflicting results, and many studies have suffered from flaws in their research methods. Animal experiments investigating the effects of radiofrequency energy (RF) exposures characteristic of wireless phones have yielded conflicting results that often cannot be repeated in other laboratories. A few animal studies, however, have suggested that low levels of RF could accelerate the development of cancer in laboratory animals. However, many of the studies that showed increased tumor development used animals that had been genetically engineered or treated with cancer-causing chemicals so as to be pre-disposed to develop cancer in the absence of RF exposure. Other studies exposed the animals to RF for up to 22 hours per day. These conditions are not similar to the conditions under which people use wireless phones, so we don't know with certainty what the results of such studies mean for human health.

Three large epidemiology studies have been published since December 2000. Between them, the studies investigated any possible association between the use of wireless phones and primary brain cancer, glioma, meningioma, or acoustic neuroma, tumors of the brain or salivary gland, leukemia, or other cancers. None of the studies demonstrated the existence of any harmful health effects from wireless phone RF exposures. However, none of the studies can answer questions about long-term exposures, since the average period of phone use in these studies was around three years.

**5. What research is needed to decide whether RF exposure from wireless phones poses a health risk?**

A combination of laboratory studies and epidemiological studies of people actually using wireless phones would provide some of the data that are needed. Lifetime animal exposure studies could be completed in a few years. However, very large numbers of animals would be needed to provide reliable proof of a cancer promoting effect if one exists. Epidemiological studies can provide data that is directly applicable to human populations, but 10 or more years follow-up may be needed to provide answers about some health effects, such as cancer. This is because the interval between the time of exposure to a cancer-causing agent and the time tumors develop—if they do—may be many, many years. The interpretation of epidemiological studies is hampered by difficulties in measuring actual RF exposure during day-to-day use of wireless phones. Many factors affect this measurement, such as the angle at which the phone is held, or which model of phone is used.

**6. What is FDA doing to find out more about the possible health effects of wireless phone RF?**

FDA is working with the U.S. National Toxicology Program and with groups of investigators around the world to ensure that high priority animal studies are conducted to address important questions about the effects of exposure to radiofrequency energy (RF).

FDA has been a leading participant in the World Health Organization International Electromagnetic Fields (EMF) Project since its inception in 1996. An influential result of this work has been the development of a detailed agenda of research needs that has driven the establishment of new research programs around the world. The Project has also helped develop a series of public information documents on EMF issues.

FDA and the Cellular Telecommunications & Internet Association (CTIA) have a formal Cooperative Research and Development Agreement (CRADA) to do research on wireless phone safety. FDA provides the scientific oversight, obtaining input from experts in government, industry, and academic

organizations. CTIA-funded research is conducted through contracts to independent investigators. The initial research will include both laboratory studies and studies of wireless phone users. The CRADA will also include a broad assessment of additional research needs in the context of the latest research developments around the world.

**7. How can I find out how much radiofrequency energy exposure I can get by using my wireless phone?**

All phones sold in the United States must comply with Federal Communications Commission (FCC) guidelines that limit radiofrequency energy (RF) exposures. FCC established these guidelines in consultation with FDA and the other federal health and safety agencies. The FCC limit for RF exposure from wireless telephones is set at a Specific Absorption Rate (SAR) of 1.6 watts per kilogram (1.6 W/kg). The FCC limit is consistent with the safety standards developed by the Institute of Electrical and Electronic Engineering (IEEE) and the National Council on Radiation Protection and Measurement. The exposure limit takes into consideration the body's ability to remove heat from the tissues that absorb energy from the wireless phone and is set well below levels known to have effects.

Manufacturers of wireless phones must report the RF exposure level for each model of phone to the FCC. The FCC website (<http://www.fcc.gov/oet/rfsafety>) gives directions for locating the FCC identification number on your phone so you can find your phone's RF exposure level in the online listing.

**8. What has FDA done to measure the radiofrequency energy coming from wireless phones?**

The Institute of Electrical and Electronic Engineers (IEEE) is developing a technical standard for measuring the radiofrequency energy (RF) exposure from wireless phones and other wireless handsets with the participation and leadership of FDA scientists and engineers. The standard, Recommended Practice for Determining the Spatial-Peak Specific Absorption Rate (SAR) in the Human Body Due to Wireless Communications Devices: Experimental Techniques, sets forth the first consistent test methodology for measuring the rate at which RF is deposited in the heads of wireless phone users. The test method uses a tissue-simulating model of the human head. Standardized SAR test methodology is expected to greatly improve the consistency of measurements made at different laboratories on the same phone. SAR is the measurement of the amount of energy absorbed in tissue, either by the whole body or a small part of the body. It is measured in watts/kg (or milliwatts/g) of matter. This measurement is used to determine whether a wireless phone complies with safety guidelines.

**9. What steps can I take to reduce my exposure to radiofrequency energy from my wireless phone?**

If there is a risk from these products—and at this point we do not know that there is—it is probably very small. But if you are concerned about avoiding even potential risks, you can take a few simple steps to minimize your exposure to radiofrequency energy (RF). Since time is a key factor in how much exposure a person receives, reducing the amount of time spent using a wireless phone will reduce RF exposure.

If you must conduct extended conversations by wireless phone every day, you could place more distance between your body and the source of the RF, since the exposure level drops off dramatically with distance. For example, you could use a headset and carry the wireless phone away from your body or use a wireless phone connected to a remote antenna.

Again, the scientific data do not demonstrate that wireless phones are harmful. But if you are concerned about the RF exposure from these products, you can use measures like those described above to reduce your RF exposure from wireless phone use.

**10. What about children using wireless phones?**

The scientific evidence does not show a danger to users of wireless phones, including children and teenagers. If you want to take steps to lower exposure to radiofrequency energy (RF), the measures described above would apply to children and teenagers using wireless phones. Reducing the time of wireless phone use and increasing the distance between the user and the RF source will reduce RF exposure. Some groups sponsored by other national governments have advised that children be discouraged from using wireless phones at all. For example, the government in the United Kingdom distributed leaflets containing such a recommendation in December 2000. They noted that no evidence exists that using a wireless phone causes brain tumors or other ill effects. Their recommendation to limit wireless phone use by children was strictly precautionary; it was not based on scientific evidence that any health hazard exists.

**11. What about wireless phone interference with medical equipment?**

Radiofrequency energy (RF) from wireless phones can interact with some electronic devices. For this reason, FDA helped develop a detailed test method to measure electromagnetic interference (EMI) of implanted cardiac pacemakers and defibrillators from wireless telephones. This test method is now part of a standard sponsored by the Association for the Advancement of Medical Instrumentation (AAMI). The final draft, a joint effort by FDA, medical device manufacturers, and many other groups, was completed in late

2000. This standard will allow manufacturers to ensure that cardiac pacemakers and defibrillators are safe from wireless phone EMI. FDA has tested hearing aids for interference from handheld wireless phones and helped develop a voluntary standard sponsored by the Institute of Electrical and Electronic Engineers (IEEE). This standard specifies test methods and performance requirements for hearing aids and wireless phones so that no interference occurs when a person uses a compatible phone and a accompanied hearing aid at the same time. This standard was approved by the IEEE in 2000.

FDA continues to monitor the use of wireless phones for possible interactions with other medical devices. Should harmful interference be found to occur, FDA will conduct testing to assess the interference and work to resolve the problem.

#### 12. Where can I find additional information?

For additional information, please refer to the following resources:

- FDA web page on wireless phones  
<http://www.fda.gov/cdrh/phones/index.html>
- Federal Communications Commission (FCC) RF Safety Program  
<http://www.fcc.gov/oet/rfsafety>
- International Commission on Non-Ionizing Radiation Protection  
<http://www.icnirp.de>
- World Health Organization (WHO) International EMF Project  
<http://www.who.int/emf>
- National Radiological Protection Board (UK)  
<http://www.nrbp.org.uk/>

July 18, 2001 For updates: <http://www.fda.gov/cdrh/phones>

## ■ Nokia One-Year Limited Warranty

Nokia Inc. ("Nokia") warrants that this cellular phone ("Product") is free from defects in material and workmanship that result in Product failure during normal usage, according to the following terms and conditions:

1. The limited warranty for the Product extends for ONE (1) year beginning on the date of the purchase of the Product. This one year period is extended by each whole day that the Product is out of your possession for repair under this warranty.
2. The limited warranty extends only to the original purchaser ("Consumer") of the Product and is not assignable or transferable to any subsequent purchaser/end-user.
3. The limited warranty extends only to Consumers who purchase the Product in the United States of America.
4. During the limited warranty period, Nokia will repair, or replace, at Nokia's sole option, any defective parts, or any parts that will not properly operate for their intended use with new or refurbished replacement items if such repair or replacement is needed because of product malfunction or failure during normal usage. No charge will be made to the Consumer for any such parts. Nokia will also pay for the labor charges incurred by Nokia in repairing or replacing the defective parts. The limited warranty does not cover defects in appearance, cosmetic, decorative or structural items, including framing, and any non-operative parts. Nokia's limit of liability under the limited warranty shall be the actual cash value of the Product at the time the Consumer returns the Product for repair, determined by the price paid by the Consumer for the Product less a reasonable amount for usage. Nokia shall not be liable for any other losses or damages. These remedies are the Consumer's exclusive remedies for breach of warranty.
5. Upon request from Nokia, the Consumer must prove the date of the original purchase of the Product by a dated bill of sale or dated itemized receipt.
6. The Consumer shall bear the cost of shipping the Product to Nokia in Melbourne, Florida. Nokia shall bear the cost of shipping the Product back to the Consumer after the completion of service under this limited warranty.

7. The Consumer shall have no coverage or benefits under this limited warranty if any of the following conditions are applicable:
  1. The Product has been subjected to abnormal use, abnormal conditions, improper storage, exposure to moisture or dampness, unauthorized modifications, unauthorized connections, unauthorized repair, misuse, neglect, abuse, accident, alteration, improper installation, or other acts which are not the fault of Nokia, including damage caused by shipping.
  2. The Product has been damaged from external causes such as collision with an object, or from fire, flooding, sand, dirt, windstorm, lightning, earthquake or damage from exposure to weather conditions, an Act of God, or battery leakage, theft, blown fuse, or improper use of any electrical source, damage caused by computer or internet viruses, bugs, worms, Trojan Horses, cancelbots or damage caused by the connection to other products not recommended for interconnection by Nokia.
  3. Nokia was not advised in writing by the Consumer of the alleged defect or malfunction of the Product within fourteen (14) days after the expiration of the applicable limited warranty period.
  4. The Product serial number plate or the enhancement data code has been removed, defaced or altered.
  5. The defect or damage was caused by the defective function of the cellular system or by inadequate signal reception by the external antenna, or viruses or other software problems introduced into the Product.
8. Nokia does not warrant uninterrupted or error-free operation of the Product. If a problem develops during the limited warranty period, the Consumer shall take the following step-by-step procedure:
  1. The Consumer shall return the Product to the place of purchase for repair or replacement processing.
  2. If "a" is not convenient because of distance (more than 50 miles) or for other good cause, the Consumer shall ship the Product prepaid and insured to:

Nokia Inc., Attn: Repair Department  
795 West Nasa Blvd.  
Melbourne, FL 32901

3. The Consumer shall include a return address, daytime phone number and/or fax number, complete description of the problem, proof of purchase and service agreement (if applicable). Expenses related to removing the Product from an installation are not covered under this limited warranty.
4. The Consumer will be billed for any parts or labor charges not covered by this limited warranty. The Consumer will be responsible for any expenses related to reinstallation of the Product.
5. Nokia will repair the Product under the limited warranty within 30 days after receipt of the Product. If Nokia cannot perform repairs covered under this limited warranty within 30 days, or after a reasonable number of attempts to repair the same defect, Nokia at its option, will provide a replacement Product or refund the purchase price of the Product less a reasonable amount for usage. In some states the Consumer may have the right to a loaner if the repair of the Product takes more than ten (10) days. Please contact the Customer Service Center at Nokia at the telephone number listed at the end of this warranty if you need a loaner and the repair of the Product has taken or is estimated to take more than ten (10) days.
6. If the Product is returned during the limited warranty period, but the problem with the Product is not covered under the terms and conditions of this limited warranty, the Consumer will be notified and given an estimate of the charges the Consumer must pay to have the Product repaired, with all shipping charges billed to the Consumer. If the estimate is refused, the Product will be returned freight collect. If the Product is returned after the expiration of the limited warranty period, Nokia's normal service policies shall apply and the Consumer will be responsible for all shipping charges.
9. You (the Consumer) understand that the product may consist of refurbished equipment that contains used components, some of which have been reprocessed. The used components comply with Product performance and reliability specifications.
10. ANY IMPLIED WARRANTY OF MERCHANTABILITY, OR FITNESS FOR A PARTICULAR PURPOSE OR USE, SHALL BE LIMITED TO THE DURATION OF THE FOREGOING LIMITED WRITTEN WARRANTY. OTHERWISE, THE FOREGOING LIMITED WARRANTY IS THE CONSUMER'S SOLE AND EXCLUSIVE REMEDY



AND IS IN LIEU OF ALL OTHER WARRANTIES, EXPRESS OR IMPLIED. NOKIA SHALL NOT BE LIABLE FOR SPECIAL, INCIDENTAL, PUNITIVE OR CONSEQUENTIAL DAMAGES, INCLUDING BUT NOT LIMITED TO LOSS OF ANTICIPATED BENEFITS OR PROFITS, LOSS OF SAVINGS OR REVENUE, LOSS OF DATA, PUNITIVE DAMAGES, LOSS OF USE OF THE PRODUCT OR ANY ASSOCIATED EQUIPMENT, COST OF CAPITAL, COST OF ANY SUBSTITUTE EQUIPMENT OR FACILITIES, DOWNTIME, THE CLAIMS OF ANY THIRD PARTIES, INCLUDING CUSTOMERS, AND INJURY TO PROPERTY, RESULTING FROM THE PURCHASE OR USE OF THE PRODUCT OR ARISING FROM BREACH OF THE WARRANTY, BREACH OF CONTRACT, NEGLIGENCE, STRICT TORT, OR ANY OTHER LEGAL OR EQUITABLE THEORY, EVEN IF NOKIA KNEW OF THE LIKELIHOOD OF SUCH DAMAGES. NOKIA SHALL NOT BE LIABLE FOR DELAY IN RENDERING SERVICE UNDER THE LIMITED WARRANTY, OR LOSS OF USE DURING THE PERIOD THAT THE PRODUCT IS BEING REPAIRED.

11. Some states do not allow limitation of how long an implied warranty lasts, so the one year warranty limitation may not apply to you (the Consumer). Some states do not allow the exclusion or limitation of incidental and consequential damages, so certain of the above limitations or exclusions may not apply to you (the Consumer). This limited warranty gives the Consumer specific legal rights and the Consumer may also have other rights which vary from state to state.
12. Nokia neither assumes nor authorizes any authorized service center or any other person or entity to assume for it any other obligation or liability beyond that which is expressly provided for in this limited warranty including the provider or seller of any extended warranty or service agreement.
13. This is the entire warranty between Nokia and the Consumer, and supersedes all prior and contemporaneous agreements or understandings, oral or written, relating to the Product, and no representation, promise or condition not contained herein shall modify these terms.
14. This limited warranty allocates the risk of failure of the Product between the Consumer and Nokia. The allocation is recognized by the Consumer and is reflected in the purchase price.
15. Any action or lawsuit for breach of warranty must be commenced within eighteen (18) months following purchase of the Product.

16. Questions concerning this limited warranty may be directed to:
- Nokia Inc.
  - Attn: Customer Service
  - 7725 Woodland Center Blvd., Ste. 150
  - Tampa, FL 33614
  - Telephone: 1-888-NOKIA-2U (1-888-665-4228)
  - Facsimile: (813) 287-6612
  - TTY/TDD Users Only: 1-800-24-NOKIA (1-800-246-6542)
17. The limited warranty period for Nokia supplied attachments and accessories is specifically defined within their own warranty cards and packaging.

## Index

---

Access codes 32  
access point 62  
answer a call 25  
antenna 18  
battery  
charge 17  
remove 15  
Bluetooth connectivity ??–82  
browser security  
security module for WAP applications 77  
Calls  
answer 25  
reject 25  
camera 64  
charge the battery 17  
connectivity  
Bluetooth ??–82  
customer care 12  
D  
data bearer 60  
digital signature 78  
Earpiece volume 26  
EGPRS 60  
GPRS 60  
icons 23  
IM  
chat 45  
contacts 46  
log in 44  
log off 48  
offline menu 44  
online menu 44  
settings 47  
indicators 23  
install SIM card 15  
instant messaging, see IM  
international calls 25  
K  
keyguard 31  
L  
loudspeaker 26  
M  
menu  
customize view 33  
how to use 33  
messages  
deleting 41  
e-mail 39  
info messages 40  
instant 43  
multimedia (MMS) 36  
service commands 41  
settings 41  
text 34  
voice 40  
Middle selection 18  
N  
Nokia Customer Care 12  
P  
phone label 12  
PIN code 32  
PIN2 code 32  
predictive text  
add new words 29  
private groups 45  
PUK and PUK2 codes 32  
R  
redial last number 25  
reject a call 25  
S  
security code 32  
security settings  
digital signature 78  
settings  
call 59  
configuration 61  
connectivity 60  
display 58  
enhancements 61  
IM 47  
lights 57  
personal shortcuts 57  
phone 59  
profiles 56  
security 62  
themes 57  
time and date 58  
shared memory 10  
shortcuts 57  
SIM card 15  
speaker phone 26  
start screen 18  
T  
time 25  
V  
video recording 64  
voice dialing 55  
W  
wallets  
signing documents through WAP 78  
WAP services  
security module in SIM 77  
signing documents 78