

Index

Main features	16
Technical specifications of Midland BT NEXT	16
Charging batteries.....	17
Unit and fixing system description	17
Switching your Midland BT NEXT on and off.....	19
Operative 'mode'.....	19
Maximum distance	19
How to pair two BT NEXT.....	20
Pairing the BT NEXT to Bluetooth devices.....	22
How to listen to the FM Radio	24
How to use the wired audio input	25
Using a PMR446 transceiver with cable connection	25
Setup and special configurations	26
Setup and firmware update	27
Warranty	27
European CE Notice Certification and Safety Approval Information	27

MIDLAND BTNext

Multi rider intercom system

BTNext is an intercom communication system solution for motor cyclists. The design is very slim and aerodynamic, all the main functions are easy to operate thanks to the big three buttons placed on the front of the unit.

BTNext is fixed on the helmet using the adhesive plate or the screw mounting clamp. Thanks to the audio kit with ultra slim speakers you can enjoy high quality stereo music while riding.

Main features

- › Intercom distance up to 1 mile (1,6Km).
- › Connect up to four people for intercom communication
- › Listen to stereo FM Radio with RDS
- › Connect your phone to receive and place phone call and listen to stereo music
- › Connect your GPS for voice street indication
- › Connection for PMR446 radio with internal or external Bluetooth
- › AUX wired connection for MP3 player and PMR446 radio
- › Setup and Firmware update via USB connection to a PC

Midland BTNext is available in two versions:

- › Single BTNext Intercom kit with one unit only
- › Twin BTNext Intercom kit with with two units

Depending on the model purchased, the package contains the following parts:

BTNext single

- › 1 BTNext communication unit
- › 1 audio kit with two stereo speakers, microphone with boom and wired microphone
- › 1 plate with bi-adhesive strip to fix the unit onto the helmet
- › 1 clamp to fix the unit onto the helmet
- › 1 stereo audio cable for iPod/ or other MP3 players
- › 1 miniUSB wall-mounting power supply
- › Wind Suppressing Foam Microphone Cover, Allen key and Velcro strip for assembly

BTNext Twin

- › 2 BTNext communication units
- › 2 audio kits with two stereo speakers, microphone with boom and wired microphone
- › 2 plates with bi-adhesive strip to fix the unit onto the helmet
- › 2 clamps to fix the unit onto the helmet
- › 2 stereo audio cable for iPod/ or other MP3 players
- › 1 miniUSB wall-mounting power supply with double plug

- › Wind Suppressing Foam Microphone Cover, Allen key and Velcro strip for assembly

The units included in the TWIN kit are already paired and can therefore be immediately used in Intercom mode.

Technical specifications of Midland BTNext

General:

- › Bluetooth ver. 2.1 stereo (Headset/Handsfree/A2DP protocol)
- › AGC system automatically controls the volume in relation to background noise
- › Voice (VOX) or manual communications activation
- › Manual controls to enable: telephone, intercom and wire connection
- › Stereo FM Radio with RDS
- › Fully waterproof
- › Lithium battery with 10 hours talk time
- › Recharge time: app. 6 hours

Bluetooth connections:

With identical device for Rider to Pillion or Bike-to-Bike Intercom mode, up to a maximum distance range of 1 mile (1,6km)

Attention: *You can reach 1 mile (1,6Km) intercom distance if the flip up antenna is up and if you are in line of site without obstructions and interferences (the riders must be always in sight).*

Bluetooth devices:

- › Mobile phone with MP3 player Stereo (A2DP protocol), GPS (Garmin Zumo and TomTom Rider 1 and 2)
- › PMR446 transceivers (with built-in or external Bluetooth connection) for group bike-to-bike communications

Wire connections:

- › For stereo audio input (iPod/MP3 player)
- › For PMR446 transceivers (with optional cable)

Attention: *Midland BTNext is designed to withstand rain and water. However, if it is raining, always verify that the rubber caps protecting the sockets are fully fitted.*

Charging batteries

Attention: Make sure that the unit is fully charged before use. Allow at least 8 hours for a full charge before using the unit for the first time.

Charge the unit by inserting the wall-charger into the charging socket (lift the rubber cover to insert the plug).

The red LED on the unit will start flashing when charging begins.

Allow the headset to charge until the unit stops flashing or the blue LED turns on. When the charge is complete (the red LED is not flashing), release the headset from the charger.

Normally, after the first time, it takes 6 hours for a full charge.

Attention: every time the mini USB recharging plug is inserted (or detached), the device is automatically turned off. To use it while it is in charge, you should turn the device on with the plug already inserted.

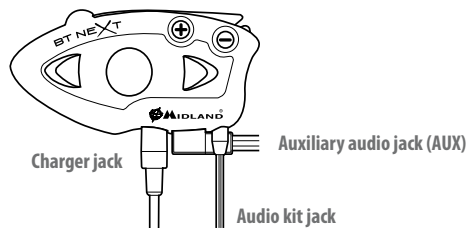

In addition the BTNext has a flip up antenna on the top for maximum distance performance.

To lift the antenna, press gently backward and the antenna will automatically lift up.

Unit and fixing system description

BT Next description

The BTNext has five buttons on the front; the main three big button are multi functions buttons: the Forward (on the left), the middle button and the Rear (on the right), the two small rounded buttons are the Volume + and Volume -.

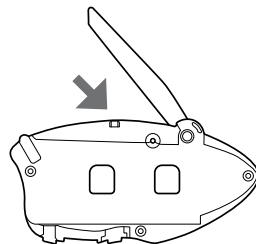

To close the antenna just press it down and be sure to move it back into the closed position.

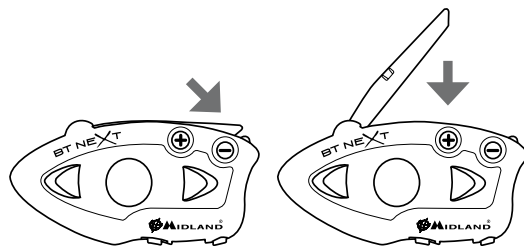
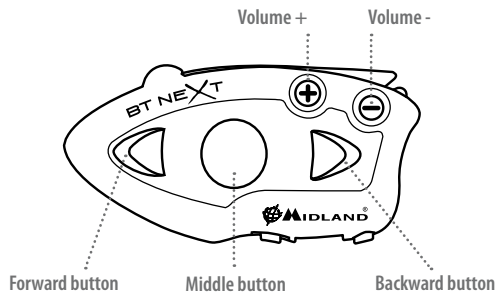

Description of the wired connections

On the bottom of the unit you can find three wired connection:

Charger jack: enables to recharge the unit using a standard miniUSB power supply

Audio kit jack: enable to connect an audio kit (stereo headset and microphone)

Auxiliary audio jack (AUX) 2.5mm: can be used to connect an audio source, like a stereo iPod/MP3 player or PMR446 transceiver

Description of the audio kit

The audio system includes two ultra-flat stereo speakers and two interchangeable microphones, which are both supplied with a bracket and wired connection.

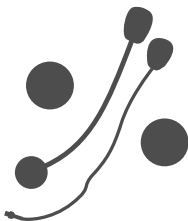

Fixing the stereo speakers

The two stereo speakers have a Velcro/adhesive strip that aids their fixing into your helmet.

Beware not to completely cover your ear with the speakers, you must always be able to listen to the traffic sound and your indicators.

The microphone can be fixed onto the helmet in two ways:

Boom Microphone

Place the section with the Velcro/adhesive strip between the padding and the rigid cover of the helmet, so that the microphone is correctly positioned in front of your mouth and that the white symbol is facing your mouth. This type of microphone is suited for Open Faced and Flip Front helmets.



Wired microphone

Using the Velcro/adhesive strip, place the microphone inside the helmet in front of your mouth. This type of microphone is more suited for Full Faced helmets. The mini connector on the microphone allows you to choose the microphone that best suits the helmet you are using.



Audio kit jack

The audio kit must then be connected to the central jack of the Midland BTNext unit using the "L" shaped connector.

Description of the installation brackets

The Midland BTNext can be fixed onto the helmet in two different ways: By either using the plate with bi-adhesive strip, or the clamp. These methods allow you to safely "fix" the BTNext unit onto your helmet and to remove it at any time in order to recharge or store it.

Plate with bi-adhesive strip

The fixing plate has a bi-adhesive strip on one of its sides. To fix the plate in place, clean the application area on the helmet surface, remove the bi-adhesive film and

place the fixing plate on the helmet by keeping it contact with the surface for a few seconds.



Screw Clamp

Using the Allen Key, loosen the two screws on the clamp and place the rear plate between the helmet padding and the external rigid protection. Then, tighten the two screws in order to firmly fix the clamp in place. Inside the clamp is included a small plastic spacer that can be removed to give a tighter fit if required.

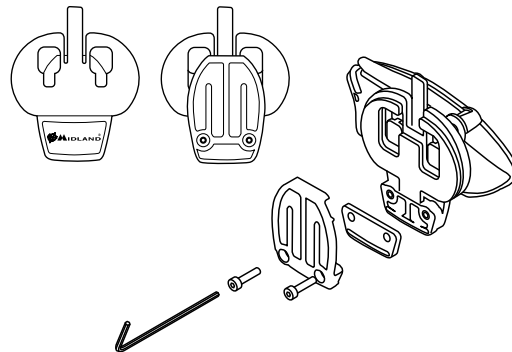

Fitting and removing your Midland BTNext

The BTNext can be easily fitted onto the helmet by sliding it downwards so that it fits into the slot of the selected fixing device (plate with bi-adhesive strip or clamp). BTNext is maintained in position thanks to the fixing clip located on the upper section (A).

To detach the BTNext, simply press the fixing clip and push the unit upwards.

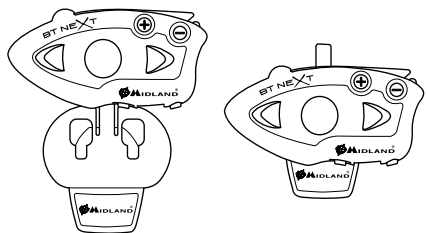

Switching your Midland BTNext on and off

Switching the unit on:

Press and hold "Middle" button down for approximately 3 seconds until the BLUE indicator lights.

Switching the unit off:

Press and hold both "Middle" and "Rear" buttons together for approximately 3 seconds until the RED indicator flashes 3 times, thus lessening the chances that you might turn off the unit accidentally (especially whilst wearing gloves).

Operative "mode"

The BTNext can operate in three main "mode": Intercom, Phone and FM Radio. The 3 multi function buttons can have different functionality depending on which mode the unit is at that moment.

- › In "**Intercom mode**" the buttons lets you manage communications with up to 4 people, talking one by one. Just press one of the three buttons to open the intercom.

- › In "**Phone mode**" you can manage your Bluetooth cellular phone to place/ answer a phone call or to listen to the music (in stereo mode). Please use your phone responsibly and safely.
- › In "**FM Radio mode**" you can listen to your favourite radio station in stereo, seek for a specific radio station and save it (6 memory are available).

You can switch (toggle) from one mode to the other simply pressing the Middle button for 3 seconds. A voice announcement will tell in which mode you are on.

The toggle sequence is the following:

- › **Intercom mode (if another unit has been paired)**
- › **FM Radio mode**
- › **Phone mode (if a phone has been paired)**

Every time you turn on the unit, the default mode is Intercom (if it was previously paired to another unit), otherwise it will be Phone (If was paired to a phone). If no pairing was made – the only possible mode is FM.

For example if you are in Intercom mode, you can use the three buttons to open and close the intercom connection to up to three other units. When you are in FM Radio mode the same buttons lets you scan the radio station frequency and turn on and off the radio.

If you want to change mode, you just press long the middle button and listen to the voice announcement, until you reach the one you are looking for.

If you need to know in which mode the unit currently is, just press the "Volume +" and "Volume –" button together. A voice announcement will tell you the current mode.

Maximum Distance

You can reach 1 mile (1,6Km) intercom distance if the flip up antenna is up and if you are in line of site without obstructions and interferences (the riders must be always in sight).

Here is an example of the buttons main functionality based on the mode you are on.

Mode	Forward (Left button)	Middle button	Rear (Right button)
Intercom	Open/close the intercom to the first rider	Open/close the intercom to the second rider	Open/close the intercom to the Third rider
Phone	Redial last number/accept or reject incoming call		
Phone (while music play)	Forward the song	Play/pause	Backward the song
FM Radio	Scan up	FM Radio On/off	Scan down

How to pair two BT Next unit

The two units supplied in the same BTNext box, are already paired and ready to use, which mean you don't need to perform this procedure. The unit are already paired using the Middle button.

If the devices are not part of the same kit, or the units has been purchased separately, you need to first pair it in order to use it.

To pair the BTNext to another BTNext unit

To pair the BTNext to another BTNext unit, you must first enter the setup mode:

1. Turn off the unit
2. Press and hold down the middle button about 7 sec., until the Red light is on permanently.
3. Now press the Middle button for 3 seconds. The Blue and Red light will flash.
4. Do the same procedure on the other unit, When successfully paired, each unit will have the Blue light on for one second and than go back to the setup mode (Red light always on).
5. Now the pairing procedure is complete, you just need to exit the setup mode before you can use the units:
6. Double click on the Middle button, the Red light will turn off and the Blue light will start flashing.

You can use now your BTNext.

How to use the Intercom with two units

To use the intercom feature, be sure the both units are turned on and correctly paired together.

Attention: For intercom communication between Driver and Passenger, there is no need to keep the flip up antenna in the up position. For Bike-to-Bike intercom the antenna must be in the upper position.

Manual activation

Press the Middle button on one of the two units. Communication is enabled and remains active until you press again the middle button. The intercom need some second to activate, you will hear a beep tone when the intercom is open.

Voice activation (VOX)

Simply start talking, after some seconds the communication will be opened and will remain active for the time you are talking. If there is no conversation the intercom will be closed after 20 seconds. If needed you can close the intercom manually without waiting 20 seconds (just press the middle button).

If needed, you can temporarily disable the VOX feature simply by pressing the Backward button for 7 sec. Two sound beep will advise you when the VOX is disabled. To turn the VOX on again, just press the same button, one beep sound will advise you that the VOX is now active (or just turn the unit off and on again).

Attention: The Voice activation (VOX) can open the intercom communication only to the unit that was paired with the Middle button. If you chose to use a different

button (Rear or), you will be able to active the intercom only manually.

Adjusting the volume

Your Midland BTNext uses AGC technology, which automatically adjusts the listening volume in relation to background noises.

However, it is also possible to manually adjust the volume by means of the "Volume +" and "Volume -" buttons.

Attention: volume can be adjust only when an audio connection is active.

How to pair the BTNext to more than two units

The BTNext unit can be paired to maximum three other BT unit (four in total).

The BTNext has three main buttons (Forward, Middle and Rear). It is up to you which button use to pair and activate the intercom, you are totally free to choose the button you like more. The same button you will use to pair the unit will be also used to activate the intercom communication.

Remember that each device can always be paired with other 3 units at your choice; as shown in the picture here below, also 'crossed' pairing can be done.

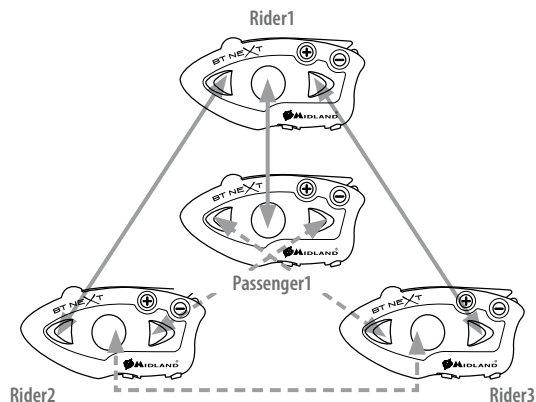

For example you can decide to pair one motorbike rider unit to the Forward button, your passenger to the Middle button and another rider to the Rear button. In this way you can have in total 4 units paired together and talk to each person, one by one, simply by pressing the corresponding button (the same used for the pairing). Every time you open the intercom connection to one person, the previous connection will be closed.

The connection is not a "chain", when two person are talking it is not possible to break (interrupt) the communication by one of the other two units riding out of the maximum distance range.

Pair the BTNext to another BTNext unit

To pair the BTNext to another BTNext unit, you must first enter the setup mode:

1. Turn off the unit
2. Press and hold down the middle button about 7 sec., until the Red light is on permanently.
3. Now press one of the three buttons (Forward, Middle or Rear) for 3 seconds depending on which button you would like use to open the intercom to the other unit. The Blue and Red light will flash.
4. Repeat the same procedure on the other unit, you don't need to use the same button, you can choose one of the three buttons not previously used.
5. When successfully paired, each unit will have the Blue light on for one second and then go back to the setup mode (Red light always on). Now the unit is ready for another pairing procedure, and you can pair another BTNext unit following the same procedure, but using a different button.

If you don't have more devices to pair, you must exit the setup mode before you can use the units:

- › Double click on the Middle button, the Red light will turn off and the Blue light will start flashing.

You can use now your BTNext.

How to use the Intercom with more than two units

To use the intercom feature, be sure that all the units are turned on and correctly paired together

Attention: For intercom communication between Driver and Passenger there is no need to keep the flip-up antenna in the up position. For Bike to Bike intercom the antenna must be in the upper position.

Manual activation

Press the button corresponding to the unit you would like to communicate with. After about 4 seconds the intercom communication will open.

The communication remains active until you press again the same button. To quickly open the intercom to another person, just press the button corresponding to the other unit, the intercom will be automatically closed and the new connection will be open (see Table A).

Voice activation (VOX)

The voice activation feature can open the intercom only to the unit paired to the Middle button. While no other communication is open, simply start talking and the communication will be open and remain active for all the time you are talking. If there is no conversation the intercom will be closed after 20 seconds. If needed you can close the intercom manually without waiting 20 seconds, pressing the Middle button.

If needed, you can temporarily disable the VOX feature simply by pressing the Rear button for 7 sec. Two sound beep will advise you when the VOX is disabled. To turn the VOX on again, just press the same button, one beep sound will advise you that the VOX is now active (or just turn the unit off and on again).

Hint: this feature is very useful when you have a specific person that you like to talk to more often (for example your passenger). In this way you don't need to press a button to open the communication.

Unit already busy

If you try to open a intercom connection to another person that is already busy talking with some one else (or is in a middle of a phone conversation), you will hear a "busy" double beep tone. Just wait sometime and try again, maybe this time the "line" is not busy.

The person who is called, will be advised that someone is trying to call and will hear a voice announcement with the number of the button from which the request is coming.

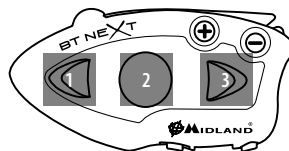

In this way as soon as the first conversation is over, the person can easily contact the caller by opening the intercom of the specific button number (indicated by the voice announcement).

A- Manual activation

Mode	Forward button	Middle button	Rear button
Intercom	Short press: Open/Close intercom to paired raider	Short press: Open/Close intercom to paired raider Long press: Change mode	Short press: Open/Close intercom to paired raider Long press: Toggle on/off wired

How to pair the BTNext to previous BT line unit

The BTNext is compatible with all the BT line unit from Midland. You can pair the BTNext to a BT2, BT1 or BTNext unit and the max distance of the intercom is defined from the lower possible.

To pair the BTNext to another BT line unit, you must first enter the setup mode:

1. Turn off the unit
2. Press and hold down the Middle button about 7 sec., until the Red light is on permanently.
3. Now press long (3 sec) one of the three buttons (Forward, Middle or Rear) depending on which button you will like to use to open the intercom to that unit. The Blue and Red light will flash.
4. Follow the procedure on the other unit's instruction manual (normally you can use the "Volume +" button on all the previous BT line units).
5. When successfully paired, each unit will have the Blue light on for one second and than go back to the setup mode (Red light always on).

Now the BTNext unit is ready for other pairing procedure, and you can pair another BT line unit following the same procedure, but using a different button on the BTNext.

If you don't have more devices to pair, you must exit the setup mode from both units before you can use them: for BT NEXT double click on the Middle button, the Red light will turn off and the Blue light will start flashing. For the other devices of BT line, please refer to their own user manual.

Pairing the BTNext to Bluetooth devices

The BTNext unit can be paired to other Bluetooth devices, like Phone, GPS Navigator or PMR446 Radio with built-in or external Bluetooth.

The pairing procedure must be done using the "Volume +" or the "Volume -" buttons.

- > **Pairing to the "Volume +" button:** for Phone with music (A2DP stereo). All devices paired to "Volume +" button has higher priority and will interrupt all the other communication (like Intercom, FM Radio and Music).
- > **Pairing to the "Volume -" button:** for GPS navigators and other devices which the audio must be always in background.

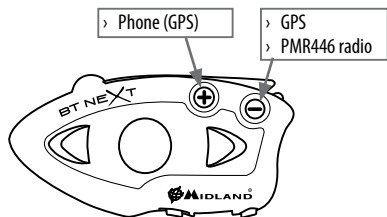

Attention: The "Volume -" button does not support the pairing with a phone or with A2DP stereo protocol devices.

Pairing to a phone

The cellular phone can be paired only to the "Volume +", in this way it is possible to manage all the phone functionalities and listen to the stereo music. An incoming call has the higher priority, that means all other communications will be closed (Intercom, FM Radio, Music).

Pairing to a GPS navigator

The GPS can be paired to the "Volume -" button. In this case the GPS street voice announcements are always in background (the intercom is not closed).

Attention: If you need to connect both Phone and GPS, you must pair the GPS to the "Volume -" button and the Phone to the GPS itself (not anymore to the "Volume +" button).

In this case the GPS street voice announcement and the phone calls are always in background and will not interrupt the Intercom conversation.

GPS Navigator with stereo music player

If the GPS is also a stereo MP3 player and you want to listen to stereo music, you must pair the GPS to the "Volume +" button. In this configuration the GPS street voice announcements will interrupt all other communication (Intercom, FM Radio, Music).

When the GPS is paired to the "Volume +" button the "Phone" mode is activated.

Pairing to a PMR446 radio with integrated or external Bluetooth

The PMR446 Radio must be paired to the "Volume -" button, so that the PMR446 radio is always in the background even when you talk on the intercom.

Attention: in addition to a PMR446 transceiver, if you want to connect also a GPS navigator you must pair the GPS to the "Volume +" button. In this configuration the GPS street voice announcements will interrupt all other communication (Intercom, FM Radio, Music).

When the GPS is paired to the "Volume +" button the "Phone" mode is activated.

How to pair the BTNext to a Phone

To pair the BTNext to a Phone, you must first enter the setup mode:

1. Turn off the unit
2. Press and hold down the middle button about 7 sec., until the Red light is on permanently.
3. Now press for 3 seconds the "Volume +" button, the Blue and Red light will flash.
4. Enable the Bluetooth device search feature on your mobile phone
5. After some seconds, "Midland BT NEXT" will be displayed on your mobile phone. Follow the pairing procedure of your Phone. If a pin code is requested you must enter "0000" (four time zero).

When successfully paired, the Blue light of the unit will be on for one second and then the unit will exit the setup mode and switch to the working mode (the Blue light will start flashing).

You can use now your BTNext together with the Phone.

How to use a Phone

After pairing your phone to the BTNext unit you must switch to the "Phone" mode in order to use it. Press the middle button until you hear "Phone" from the voice announcement. Now all the three main button are dedicated to the phone (see Table B)

Answering a call

When you hear the phone ring, you can answer in two different ways:

Vocally:

Simply say one word to answer the call and start talking.

Remembering that you can only do this if you answer the call after the third Ring.

Attention: be aware that some phones may not support voice answering

Manually:

Tap the "Forward" button and start speaking.

Rejecting a call

If you don't wish to answer, you can let the mobile phone ring or press the "Forward" button for a few seconds (you will hear one audio confirmation tone).

Making a call

There are several ways to make a call.

From the mobile keypad:

Dial the number on the mobile keypad:

Press "Send" on the mobile phone.

To redial the last number:

Press "Forward" button for 3 seconds in order to redial the last number (you will hear one audio confirmation tone).

To make a voice call:

Briefly press "Forward" button. If your mobile phone supports voice calls, you will be asked to speak the name of the contact you wish to call.

Priority: Calls have a high priority, which means that all other communications are temporarily disabled when a call arrives and automatically re-enabled once the call ends.

Ending a call

There are several ways to end a call:

- > Wait for the called person to end the call.
- > Press the "Forward" button (you will hear an audio confirmation tone).
- > Press "End" button on the mobile phone.

Using the MP3 player feature of the mobile phone

Many mobile phones are now designed to be used as stereo MP3 players. The BTNext device fully supports the A2DP and AVRCP protocols that enable you to listen to stereo music and remotely control your mobile phone's MP3 player. You can even use the buttons on the BTNext unit to control the following play options: Play, Pause, Forward and Backward.

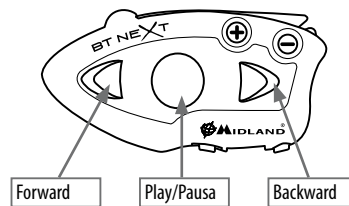

Available controls:

- > To play/pause music: click on the "Middle" button.
- > To skip forward to the next song: press the "Forward" button.
- > To skip backwards to the previous song: press the "Rear" button..

B-Phone mode

Mode	Forward button	Middle button	Rear button
Phone	Short press: Voice dial /accept or close if it is in progress Long press: redial last number/ or reject incoming call	Long press: Change mode	Long press: toggle on/off wired
Phone (when music play)	Short press: Forward the song	Short press: Play/pause Long press: Change mode	Short press: Backward the song

Priority: the music listening mode has the lowest priority. Therefore, it will always be disabled when another type of communication is enabled.

How to pair the BTNext to a GPS

In general is possible to pair the BTNext to all the GPS for motorbike that support Bluetooth headset connection.

To pair the BTNext to a GPS, you must first enter the setup mode:

1. Turn off the unit
2. Press and hold down the "Middle" button about 7 sec., until the Red light is on permanently.
3. Now press firmly (3 sec) the "Volume -" button, the Blue and Red light will flash.
4. Enable the Bluetooth device search feature on your GPS
5. After some seconds, "Midland BT NEXT" will be displayed on your GPS.
6. Follow the pairing procedure of your GPS. If a pin code is requested you must enter "0000" (four times zero).
7. When successfully paired, the Blue light of the unit will be on for one second and then the unit will exit the setup mode and switch to the working mode (the Blue light will start flashing).

You can now use your BTNext and the GPS street voice announcement are always in background.

If you pair the GPS to the Volume + button (because for example the "Volume -" button was already used), you lose the possibility to pair the phone to the BTNext unit. You can overcome this limit by pairing the phone directly to the GPS and then the GPS to the BTNext unit. All the phone features are therefore managed by the GPS itself.

How to use a GPS

When paired using the "Volume -" button the GPS will be automatically connected and the voice announcement are always in background also if the intercom is active.

When the GPS is paired to the "Volume +" button, the street voice announcement will always interrupt the intercom. In addition, remember to switch to "Phone" mode in order to listen and control the music (play/pause - backward and forward).

If the phone is connected thru the GPS you must use the control buttons on the GPS screen in order to control the phone functionality.

How to pair PMR446 transceiver with integrated Bluetooth

If your PMR446 transceiver has an integrated Bluetooth (like the G8BT), you must pair the transceiver using the "Volume -" button:

- › Turn off the unit
- › Press and hold down the "Middle" button about 7 sec., until the Red light is on permanently.
- › Now press firmly (3 sec) the "Volume -" button, the Blue and Red light will flash.
- › Follow now the pairing procedure explained on the manual of the transceiver itself

Attention: If you are pairing to a G8BT transceiver, just when the BTNext finish the pairing (only the Blu LED is flashing) you must follow this procedure to activate the Bluetooth connection:

- › Turn off and on the G8BT and then press for 3 sec. the "BT" button.
- › Follow the same procedure every time you need to reconnect the G8BT to the BTNext (no need to make the pairing procedure again)

How to listen to the FM Radio

The FM Radio receiver is integrated inside the unit. You just need to switch to the "FM Radio" mode in order to use it. Long press the middle button until you hear "FM radio" from the voice announcement. Now all the three main button are dedicated to the FM Radio (See Table C).

Attention : To toggle wired on/off pressing long the Backward button, you need first to stop the FM Radio (Press the Middle button briefly).

When you press the Forward or the Backward button briefly, you can scan up or down the 6 recorded stations. A voice announcement will tell you the number of which memory you are entering. A double beep tone will be played when the last or the first recorded station is reached.

To save the station you are listening, press the Forward and Rear buttons together for 3 sec. You will hear a beep tone for confirmation.

The station is saved over the last recorded station used.

Thanks to the RDS system, the FM Radio will choose the strongest signal available for the radio station you like to listen.

The RDS system is OFF by default, if needed you can toggle on/off the RDS pressing together the "Volume +" and "Volume -" buttons for 3 sec when the radio is on. A voice announcement will tell you the RDS status.

C-Radio FM mode

Mode	Forward button	Middle button	Rear button
FM Radio	Short press: Scan recorded Long press: seek station up	Short press: On/off Long press: Change mode	Short press: Scan recorded Long press: seek station down

FM Radio with intercom

When you are in “FM Radio” mode it is not possible to manually open the intercom, you can only open it using VOX feature (just talk) to the unit paired on the “Middle” button. To manually activate the intercom you must switch to “Intercom” mode.

How to use the wired audio input

Your Midland BTNext is also supplied with a wired audio input (AUX), that can be used to connect an audio source, like an iPod (or any other MP3 Player) or a PMR446 transceiver for group communication or for a coverage increase.

Listening to music

To listen to music from the wired input, connect the audio source using the cable supplied with the BTNext unit. The volume level can be adjusted using the Volume + and Volume – button, or automatically adjusted by the AGC system, which means that you only need to adjust the volume of your iPod/ MP3 player to a level that will allow you to listen to music in normal speed.

Attention: *never set the volume of the MP3 Player to the maximum possible. Normally the best level is about the 70% of the maximum.*

Hint: We recommend that you perform a few tests adjusting the volume of your iPod/MP3 player so at the normal speed the Headset volume is suited to your needs. The AGC system will automatically increase the volume on higher speed. Make a note to remember this setting for future trips.

Enabling/disabling the wired input

If needed the wired input can be enabled or disabled:

Enabling/Disabling: Make a Long press on the “Rear” button (you will hear one audio beep tone for enabling confirmation and two audio beep tone for disabling).

Attention: *if you are in FM mode, you must first turn off the radio and then make a “long” press on the Rear button.*

Priority

The BTNext manage the different connection/audio sources based on the following priority rules.

Changing of the operative mode

Every time you change mode (long press of the middle button to toggle between Intercom/ FM Radio / Phone), the previous audio is closed and the control goes to the new mode.

Intercom

The Intercom has always a higher priority against the music from the FM Radio or Phone (including GPS in music play mode). Every time you open the intercom the music from a Bluetooth source is stopped. Only the audio/Music from the “AUX wired connection” is always in background by default.

Phone calls

The phone call has always the higher priority and will interrupt every connection, like music, intercom. Only the AUX wired connection can be still on if the setting “Wired connection always in background” was enabled.

GPS voice announcement

The voice announcements from the GPS are available in background also during intercom

AUX wired connection

Music or audio from the AUX wired connection, by default it is always in the background also when the intercom is open or during a phone call. It is possible to change this behavior following the procedure described in the “Setup and Special configuration” chapter.

Using a PMR446 transceiver with the cable connection

In order to connect the transceiver to your Midland BTNext, you need to purchase the specific 2.5mm plug AUX cable, sold separately. Some manufacturers radios use a different pin configuration, so we recommend that you ask your dealer as to which cable is best suited to your needs

The cable connected to the transceiver normally has also a PTT button that can be placed on the handlebar of your bike or held in your hand (If you are the pillion rider).

To communicate via the attached radio, press the PTT button to speak and release it to listen. It is not possible to talk and listen simultaneously.

Adjust the volume of the transceiver to your needs, remembering that the volume adjustment is controlled by the automatic AGC system and that it will therefore be automatically increased in relation to background noise.

If you wish to use a PMR446 transceiver for group communications and simultaneously maintain the Intercom feature enabled between two or more BTNext devices, you must remember that every time you talk to communicate with the PMR 446 transceiver (pressing the PTT button), you will also activate the intercom of the BTNext to the unit connected to the “Middle” button (thanks to the VOX feature).

Every time you change mode (long press of the middle button to toggle between Intercom/ FM Radio / Phone), the previous audio is closed and the control goes to the new mode.

To avoid the Intercom activation when you speak on the PMR446, you can decide to pair the BTNext unit on the “Rear” or “Forward” (where the VOX is not active) or if you still want to use the “Middle” button, you must disable the VOX feature, as

explained in the previous section.

Attention! If you disable the VOX feature, you will only be able to answer incoming phone calls by pressing the “Forward” button.

Setup and special configurations

Resetting all paired devices

Sometimes you may find it necessary to delete all the pairing references stored in the BTNext unit (reset operation).

To perform this operation you must first enter the setup mode:

- › Turn off the unit
- › Press and hold down the “Middle” button about 7 sec., until the Red light is on permanently.
- › Then simultaneously press and hold down the “Volume +” and “Volume -” buttons for 3 seconds. The Blue Light will be lit on for 1 sec and then back to steady RED.
- › Double click on the “Middle” button to exit the “Setup” mode and use the BTNext.

This procedure deletes all the paired Bluetooth devices stored in the memory and it is therefore possible to start a new “clean” pairing session.

Back to factory setting

Sometimes you may find it necessary to go back to the factory setting, to reset all the changes/setup already made and have a “clean” unit.

To perform this operation you must first enter the setup mode:

- › Turn off the unit
- › Press and hold down the “Middle” button about 7 sec., until the Red light is on permanently.
- › Then simultaneously press and hold down all the three buttons “Forward”-“Middle”-“Rear” for 3 seconds. The Blue Light will be lit on for 1 sec and then back to steady RED.
- › Double click on the “Middle” button to exit the “Setup” mode and use the BTNext.

Adjusting/ Disabling the VOX feature (Intercom and telephone)

The Intercom feature can be enabled both manually and vocally (VOX). The VOX activation is influenced by the background noise and therefore by the speed. For optimum results, it is possible to choose one of the following four microphone sensitivity levels: high, medium, low and very low. The default setting of BTNext is “low”. It is also possible to disable the VOX feature in order to activate the Intercom and phone call answering features in manual mode only.

Adjusting the sensitivity of the microphone (VOX)

To perform this operation you must first enter the setup mode:

1. Turn off the unit
2. Press and hold down the “Middle” button about 7 sec., until the Red light is on permanently.
3. Your BTNext is now in “Set up mode”.
4. Press the “Rear” button until the red light indicator changes to a steady blue.
5. Now, press “Volume +” or “Volume -” to increase or reduce sensitivity. Every time you press the Volume buttons the RED light will flash for confirmation. When you reach the end of the upper and lower limit, the RED light will not flash.
6. Press again the “Backward” button; the Blue light will flash several times, in order to let you know the selected sensitivity:
 - One flash = VOX disabled
 - Twice = very low sensitivity
 - 3 times= low sensitivity
 - 4 times= medium sensitivity (default setting)
 - 5 times = high sensitivity
 The light indicator is now back to steady RED (“Set up mode”) and the changes are confirmed
7. If needed, you can adjust again the sensitivity repeating the steps from point 1, otherwise exit the Setting mode by double clicking the “Middle” button. Once the red light turns off, the blue led starts blinking. Now you can use your BTNext.

Disabling the VOX feature (Intercom and telephone)

Follow all the procedure described in the previous steps and choose the option of only one flash (VOX disabled).

Wired connection always in background

This feature let you keep the wired connection always on, even when the phone or the intercom is open. This feature can be useful when you connect a PMR446 transceiver.

By default this option is on.

Disabling:

- › Enter the “Setup” mode:
- › Turn off the unit
- › Press and hold down the “Middle” button about 7 sec., until the Red light is on permanently.
- › Press the “Forward” and “Middle” button together for 3 seconds. The blue LED will flash twice.
- › Double click on the “Middle” button to exit the “Setup” mode and use the BTNext.

Enabling:

Follow the same procedure up described; now the blue LED will flash once. To exit the "Setup" mode, double click the "Middle" button.

Setup and Firmware update

It is possible to configure and update the firmware of your BTNext using the USB connection to your PC. On the Midland web site www.midlandradio.eu in the BTNext page you can find the PC software and the new firmware updates if available.

ATTENTION DO NOT CONNECT THE UNIT TO THE PC BEFORE you DOWNLOAD AND INSTALL THE SOFTWARE

Use at your own risk

The use of the device will impair your ability to hear other sounds and others around you.

Listening to music or speaking on a telephone may prevent you from hearing others around you and distract you from riding safely. The use of such device while riding may endanger you and others, and its use, in some areas, could not be allowed.

Using this device at a high volume may result in permanent hearing loss.

If you experience ringing in your ear or any other hearing related pain, reduce the volume or discontinue using this device. With continued use at high volume, your ears may become accustomed to the sound level, which may result in permanent damage to your hearing.

Please use this device at a safe volume level.

FCC Compliance Information

This device complies with Part 15 of the FCC Rules. Operation is subject to the following two conditions: (1) this device may not cause harmful interference, and (2) this device must accept any interference received, including interference that may cause undesired operation.

You are cautioned that changes or modifications not expressly approved by the part responsible for compliance could void the user's authority to operate the equipment.

"This device complies with Industry Canada licence-exempt RSS standard(s). Operation is subject to the following two conditions: (1) this device may not cause interference, and (2) this device must accept any interference, including interference that may cause undesired operation of the device."

"This equipment complies with Industry Canada radiation exposure limits set forth for an uncontrolled environment."

NOTE: This equipment has been tested and found to comply with the limits for a Class B digital device, pursuant to part 15 of the FCC Rules. These limits are designed to provide reasonable protection against harmful interference in a residential installation. This equipment generates, uses and can radiate radio frequency energy and, if not installed and used in accordance with the instructions, may cause harmful interference to radio communications. However, there is no guarantee that interference will not occur in a particular installation. If this equipment does cause harmful interference to radio or television reception, which can be determined by turning the equipment off and on, the user is encouraged to try to correct the interference by one or more of the following measures:

- › Reorient or relocate the receiving antenna.
- › Increase the separation between the equipment and receiver.
- › Connect the equipment into an outlet on a circuit different from that to which the receiver is connected.
- › Consult the dealer or an experienced radio/TV technician for help.

