



ProLine



ML3215 /
ML3245
Operating

Table of Contents

FCC RF Exposure Compliance Requirements - for Occupational Use Only.....	1	
Safety Information.....	1	
About Topaz3.....	2	
About Your Legacy ProLine Radios.....	2	
Unpacking and Checking Equipment.....	2	
Radio Control Buttons / Operation Features.....	3	
Radio Operation.....		4
Power On /		
Transmit.....	4	
Radio Functions.....		4
Tone		
Signaling.....	4	
Scan Modes.....		5
Normal Channel		
Scan.....	5	
Priority Scan TX		5
Priority Look Back Scan		
.....	5	
Priority Select Scan.....	5	
Vacant Channel Scan.....	5	
Nuisance Delete.....	5	
Busy Channel Lockout.....	5	
Marked Idle.....	5	
TX Delay.....	5	
Time-Out-Timer (T-O-T).....	5	
Time-Out-Timer Penalty (TX Inhibit).....	5	
Two-Tone Decode.....	5	
VOX (Voice Operated X-mit)	5	
P/A Mode	5	
Mode Operation and Function Setup.....	6	
Power On.....	6	
Channel Change.....	6	
Transmit	6	
Channel Option View.....	6	
Channel Option Settings Menu	6	
System Option Settings Menu	10	
Display Option Settings Menu	13	
P/A Option Settings Menu	14	
ACC-733 DTMF Microphone Operation.....	14	
Licensing and Service Information.....	15	
FCC Licensing.....	15	
Service.....	15	
Maintenance.....	15	
Software Copyrights.....	16	
Topaz3 / Legacy Product Warranty.....	16	

FCC RF Exposure Compliance Requirements - for Occupational Use Only

The Federal Communications Commission (FCC), with its action in General Docket 93-62, November 7, 1997, has adopted a safety standard for human exposure to Radio Frequency (RF) electromagnetic energy emitted by FCC regulated equipment. Topaz3 / Maxon subscribes to the same safety standard for the use of its products. Proper operation of this radio will result in user exposure far below the Occupational Safety and Health Act (OSHA) and Federal Communications Commission limits.

Antennas used for this transmitter must not exceed an antenna gain of 0dBd. The radio must be used in vehicle-mount configurations with a maximum operating duty factor not exceeding 50%, in typical push-to-talk configurations. This radio is NOT approved for use by the general population in an uncontrolled environment. This radio is restricted to occupational use, work related operations only where radio operator must have the knowledge to control the exposure conditions of its passengers and bystanders by maintaining the minimum separation distance of 47.7 inches (121 cm) between any persons and the antenna. Failure to observe these restrictions will result in exceeding the FCC RF exposure limits.

CAUTION - DO NOT transmit for more than 50% of total radio use time (50% duty cycle). Transmitting more than 50% of the time can cause FCC RF exposure compliance requirements to be exceeded. The radio is transmitting when the "TX" icon on the radio display is illuminated. You can cause the radio to transmit by pressing the P-T-T button on the radio's microphone.

CAUTION - DO NOT operate the transmitter of ML3215, ML3245 mobile radios when someone (bystanders) outside the vehicle is within 47.7 inches (121 cm) of the antenna.

Antenna installation must be limited to the center of the roof-top of a vehicle where the passengers are below the metallic ground plane (roof-top) to ensure compliance.

NOTE: This radio operates in FCC regulated frequency bands. All radios must be licensed by the FCC before use. Because this radio contains a transmitter, Federal law prohibits unauthorized use or adjustments of this radio.

This device complies with Part 15 of the FCC Rules. Operation is subject to the condition that this device does not cause harmful interference.

Safety

CAUTION - DO NOT operate the transmitter of any radio unless all RF connectors are secure and any open connectors are properly terminated.

CAUTION - DO NOT operate the radio near electrical blasting caps or in an explosive atmosphere.

CAUTION - All equipment must be properly grounded for safe operation.

WARNING - DO NOT allow children to operate transmitter - equipped radio equipment.

WARNING - All equipment should be serviced by a qualified technician.

WARNING - It is mandatory that radio installations in vehicles fueled by liquefied petroleum gas conform to the following standard: National Fire Protection Association Standard NFPA 58 applies to radio installations in vehicles fueled by liquefied petroleum (LP) gas with LP gas container in the trunk or other sealed-off space within the interior of the vehicle. This standard requires that:

1. Any space containing radio equipment shall be isolated by a seal from the space in which the LP gas container and its fittings are located.
2. Remote (outside) filling connections shall be vented to the outside.

About Topaz3

Topaz3 is the exclusive supplier of Maxon®, Legacy and TruTalk brand communication products.

Our product line ranges from FCC licensed two-way radios suitable for Business and Industry (B&I) markets like farm, government, law enforcement, utility, etc. to consumer communications equipment for recreational and light-duty business markets.

Product offerings include a variety of UHF and VHF handheld and mobile radios, repeaters and RF link modules as well as GMRS (General Mobile Radio Service) radios, MURS (Multi User Radio Service) radios, Citizen's Band radios and weather monitors.

Available accessory items include a variety of carrying cases, spare batteries, desktop and mobile chargers, ear bud speaker microphones and more for each radio model.

For additional information on our product line, visit our website: www.topaz3.com

About Your Legacy ProLine Radio

The Legacy ProLine models ML3215 (VHF) and ML3245 (UHF) are fully programmable, synthesized radios featuring:

- 32 Channels of operation
- 8-Character alphanumeric display
- 2 or 45 Watts output power
- Channel scan
- 38 Standard and 11 non-standard CTCSS tones
- 104 DCS Codes
- Approved to MIL-STD810F specifications
- Scan channel delete
- Busy channel lockout
- Programmable CTCSS / DCS tones and two-tone decode
- Wide / narrow channel spacing
- TX Inhibit
- VOX operation
- Public address mode
- Nuisance Delete
- Die-cast aluminum frame, polycarbonate cabinet

Please read this manual thoroughly before operating the radio. Application of some functions described in this manual are determined by the system you use. Your radio communications Dealer will program your radio for you to have the greatest number of functions possible relative to your needs.

Should you have questions regarding the operation of this radio, consult your radio communications Dealer, or contact the Topaz3 Customer Service Department: 1-800-821-7848, Ext. 499.

Unpacking Information

Carefully unpack the radio and its accessories. Use the item list below to identify the components included in the product packaging, to ensure that no items are discarded in the packing materials.

Radio Body
Microphone

Radio Control Buttons / Operation Features

Radio Front

- A. **Power / volume control** - Powers radio on and adjusts radio volume.
- B. **Squelch control** – adjust radio carrier squelch setting.
- C. **Microphone jack** – Attaches standard microphone or optional DTMF microphone.
- D. **Backlit LCD** - Provides visual confirmation of radio settings.
- E. **T/A button** – Bypass a repeater tower on a repeater channel pair for radio to radio communications.
- F. **Scan button** – Enters channel scanning of channels in scan list.
- G. **Mode button** – Enters menu tree for turning on / off radio features and functions.
- H. **Monitor button** - Press and hold to turn radio squelch off; release to turn squelch on.
- I. **Weather** – Selects NOAA weather channels, press scan to scan for nearest weather channel.
- J. **Auxiliary button** – Toggles on or off an installed option.
- K. **Channel selector buttons** – Selects channel and used in conjunction with mode button.
- L. **Speaker**

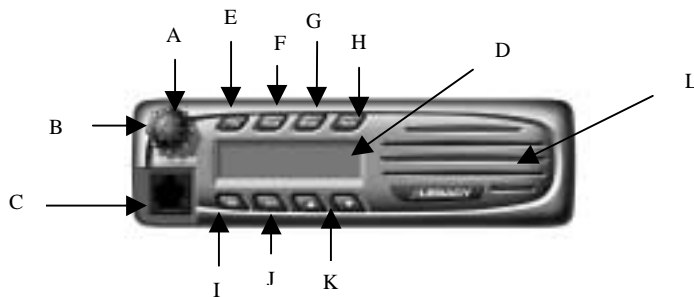

Radio Back

- A. **Antenna connector**
- B. **15 pin interface connector**
- C. **3.5 mm mono external speaker jack**
- D. **13.8V DC Power cord**

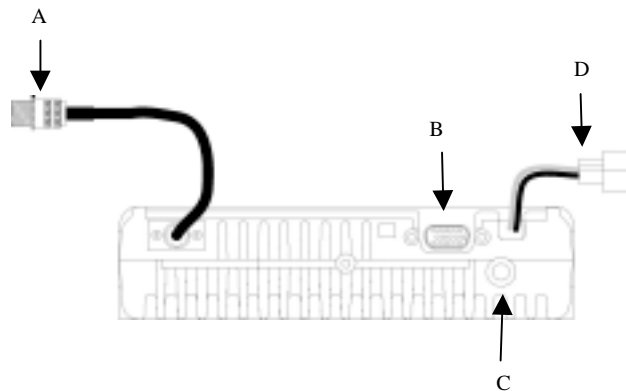

Backlit LCD Features

- A. **8-Character alphanumeric display** - Shows current channel setting, CTCSS or DCS tone code setting, and other function indicators.
- B. **Transmit (TX) indicator**
- C. **Receive (RX) indicator**
- D. **Voice Operated Transmission (VOX) indicator** - Shows VOX operation is active, allowing hands-free radio transmissions
- E. **Monitor (MON) indicator** – Shows monitor mode (used to open squelch and check for channel activity).
- F. **Time Out Timer (TOT) indicator** - Shows transmit timer mode is active, which prevents transmissions when timer expires.
- G. **Weather (WX)** – Shows NOAA weather station mode.
- H. **T/A** - Shows repeater bypass activated.
- I. **Auxiliary (AUX)** – Shows internal auxiliary option is active.
- J. **Scan (SCAN) indicator** - Shows scan function is active.
- K. **Audible Tone (BEEP) Indicator** - Shows "beep" tone function is active.
- L. **High power (H) indicator** - Shows high power is active (used for increased range and penetration).
- M. **Low power (L) indicator** - Shows low power is active (used for battery conservation in short range conditions).

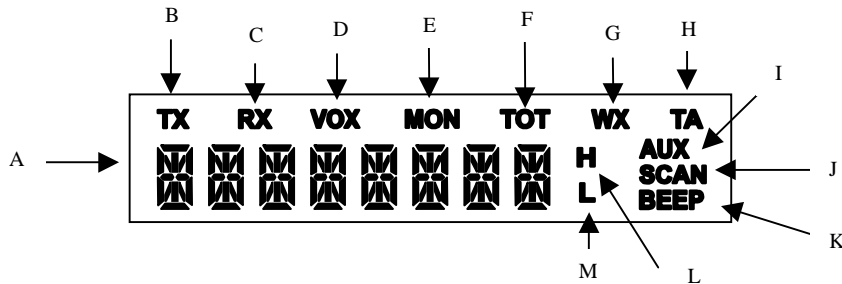

Radio Operation

Power On / Transmit

Power on the radio by turning the power / volume control (A) clockwise out of detent. You will hear a confirmation tone on power-up and display will show **POWER**. To check the radio volume, press and hold the monitor button (B) then rotate the control to desired volume level.

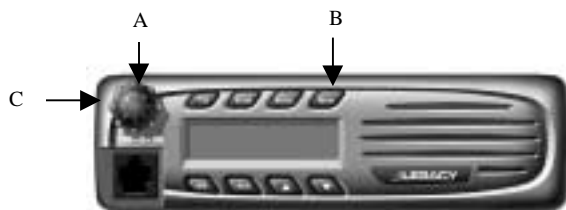

Adjust the squelch setting located behind the volume control by rotating the squelch control (C) counter clockwise for loose squelch and fully clockwise for tight squelch.

Press up or down channel selector buttons to choose the desired channel. Press the monitor button to check the channel for activity. To avoid interrupting another user, make sure the channel is clear before you begin transmitting.

To transmit, place the radio microphone approximately 2" (5 cm) from your mouth. Press and hold the P-T-T bar while speaking in a normal tone. Release the P-T-T bar when you are finished speaking; the radio will be placed into receive mode.

Radio Functions

Tone Signaling

To help block out unwanted calls to your ProLine ML3215 / ML3245 can be programmed to look for privacy tones.

Scan Modes

Scanning is a Dealer programmable feature that allows you to monitor a number of channels. Your radio communications Dealer will help you define a scanning mode and your channel "scan list".

Once the scan list has been established, initiate scan by pressing the **SCAN** button. The **SCAN** icon will show in the lower right corner of the display to confirm radio scanning.

Normal Channel Scan

If a conversation is detected on any of the channels in the scan list, the radio will stop on that channel and you will be able to hear the conversation. In normal scan, you can transmit on that active channel during the programmable scan delay time. (The scan delay time is the amount of time the radio will stay on that channel once activity has ceased. Dealer programmable, 4 – 7 seconds is typical).

The radio will resume scanning once the scan delay time has expired, and will continue to scan until the channel is changed. In scan mode, if radio power is turned off and on, the radio will return to the scan mode until a channel is changed.

Priority Scan TX

A single channel may be programmed as the "Priority" channel. Priority channel activity takes precedence over all other conversations. During the scan mode, if a P-T-T is initiated the radio will transmit on the Priority channel. The radio will constantly monitor this channel while scanning and when stopped on an active channel. If a call is detected on the priority channel, the radio will automatically move to, and remain on, the Priority channel.

Priority Lookback Scan

A single channel may be programmed as the "Priority" channel. The radio will constantly monitor this channel while scanning and when stopped on an active channel. If a call is detected on the Priority channel during a conversation, the radio will automatically move to, and remain on, the Priority channel. Priority channel activity takes precedence over all other conversations.

Priority Select Scan

A selected channel becomes the "Priority" channel. As you change the channel, that channel's frequency will become your new Priority channel. Priority channel activity takes precedence over all other conversations.

Nuisance Delete

During receiving a signal or scan delay time, if the **MON** (monitor) button is pressed, the current receiving channel is deleted in scan list and is no longer scanned. When the power is turned off and on, the deleted channel is restored to the scan list.

Busy Channel Lockout

When the RX signal is being received, the radio's transmitter is disabled.

Marked Idle

When used in conjunction with Busy Channel Lockout (BCLO), the radio will allow a transmission if the correct tone is present with the received signal.

TX Delay

The transmission will remain active for approximately 180 milliseconds even though the P-T-T bar is released when using CTCSS Tones. This eliminates squelch tail.

Time-Out-Timer (TOT)

The purpose of the time-out-timer is to prevent any single person from using a channel for an extended period. The time-out time can be programmed from 10 seconds to 990 seconds.

Time-Out-Timer Penalty (TX Inhibit)

When time-out-timer is applied, transmission will be inhibited after the time-out-time time expires. This TX inhibit time can be selected and programmed by your radio communications Dealer from 1 second to 100 seconds. For instance, when the time-out time is set to 3 minutes and T-O-T penalty is set to 5 seconds, if you continuously transmit for 3 minutes, the radio will stop transmitting. A tone will sound with each P-T-T bar press until the 5 second TX inhibit time expires.

Press the P-T-T bar after the TX inhibit time expires to resume transmitting.

Two-Tone Decode

Each channel can be programmed with two-tone decode selections: Individual Call, Group Call and Super Group Call. Your radio communications Dealer can program your radio(s) for this feature. To activate or reset the two-tone decode, press and hold the AUX button for 3 seconds. After two-tone is decoded an alarm will sound if two tone alarm is turned on.

VOX (Voice Operated TX)

Allows your radio to transmit with the sound of your voice for hands-free operation. Your radio has a VOX sensitivity level adjustment for noisy or windy conditions. The VOX icon will be displayed when option is active.

P/A Mode

Allows your radio to become a public address system with an optional external speaker connected. In this mode only microphone audio heard over the optional external speaker when the P-T-T bar is pressed.

Mode Operation and Function Set Up

Depending on how your Dealer has programmed your radio, you may be able to change certain modes and functions of your radio. Consult with your radio communications Dealer regarding which functions are available with your radio.

The following identifies display prompts for various radio functions. NOTE: All functions are activated or turned off by pressing the MODE button. Use the up or down buttons to toggle through the choices available with each function. To exit, press the MODE or P-T-T bar on the microphone.

Power On

Power on the radio by turning the power / volume control knob clockwise out of detent. The radio will perform a self-check, showing **POWER** in the display. Two beeps are sounded when the radio is ready to enter normal operation mode. If power-on detects an error to data in the last memory, the **EEP Err** display will appear, and an error tone will beep.

Channel Change

Press and release the up or down. Your display will change with each channel selection, and will vary depending on how your Dealer programmed each channel description. A press and hold of up or down will scroll through the channels.

Transmit

Press the P-T-T bar to transmit on the microphone; release to receive. Both TX (transmit) and RX (receive) are indicated by display icons. When the VOX option is set and activated by voice, the radio transmits; if voice input stops, the radio maintains TX for around 2 seconds, then returns to receive mode.

Channel Option View

In receiving mode, if the MON (monitor) button is pressed for more than 2 seconds, the RX tone option and the TX tone option for each channel selected will display.

This display example identifies:

RCTC 01 Rceive, CTCSS, Tone 1

This display example identifies:

TJCS 023 Transmit, CTCSS, Tone 1

Channel Option Settings Menu

NOTE: These setting instructions are per-channel. You must repeat for all channels. To enter the Menu setting, press and release the MODE button during the receive or standby mode. In the menu setting, use the up or down buttons to scroll through the sub-menu settings. To enter a sub-menu, press the MODE button when the desired sub-menu appears on screen, then press the up or down buttons to scroll through the sub-menu selections. To activate or turn off a sub-menu setting, press and release the MODE button. The radio will save the setting, and return to standby mode.

If the P-T-T button is pressed, the radio returns to standby mode. If the MON (monitor) button is pressed, the radio will return to the previously displayed Menu setting.

The Channel Options Settings menu and sub-menus are detailed on the next few pages

Press up or down to the desired channel. Press the MODE button and then the up or down button until **Ch SET** appears. Press and release the MODE button to select. Sub-menu settings include: **TONE SET** , **Tx POWER** ,

NO r SCAN , PRI SCAN , and TWO TONE .

Scroll through the sub-menu settings with the up or down buttons. To enter a sub-menu, press the MODE button when the desired sub-menu appears on screen.

TONE SET settings include: R \times TONE

T \times TONE

You can toggle between these settings with the up or down buttons. When the desired setting appears on screen, press the MODE button. Under the RX Tone and TX tone settings, your choices toggle between NO TONE , CTCSS , DCS , and **DCS** (No Tone, Continuous Tone Coded Squelch System tones, Digitally Coded Squelch tones and Invert Digitally Coded Squelch tones).

If you choose the **CTCSS tone setting**, you will need to use the up or down buttons to select the desired tone code of 49 available. If you choose CTCSS code 1, your display will read: CTCSS 01

If you choose CTCSS code 49, your display will read: CTCSS 49

When the desired CTCSS tone code appears on the display, select and set your choice by pressing the MODE button or the P-T-T. The radio will save your selection and return to standby mode.

CTCSS Tone Signaling Frequency Table

No.	Freq.	No.	Freq.	No.	Freq.	No.	Freq.	No.	Freq.
01	67.0	11	97.4	21	136.5	31	192.8	41	171.3
02	71.9	12	100.0	22	141.3	32	203.5	42	177.3
03	74.4	13	103.5	23	146.2	33	210.7	43	183.5
04	77.0	14	107.2	24	151.4	34	218.1	44	189.9
05	79.7	15	110.9	25	156.7	35	225.7	45	196.6
06	82.5	16	114.8	26	162.2	36	233.6	46	199.5
07	85.4	17	118.8	27	167.9	37	241.8	47	206.5
08	88.5	18	123.0	28	173.8	38	250.3	48	229.1
09	91.5	19	127.3	29	179.9	39	69.3	49	254.1
10	94.8	20	131.8	30	186.2	40	159.8		

If you choose the **DCS tone code setting**, you will need to use the up or down buttons to select the desired tone code of 105 available. If you choose DCS code 023, your display will read: DCS 023

If you choose DCS code 754, your display will read: DCS 754

When the desired DCS tone code appears on the display, select and set your choice by pressing the MODE button or the P-T-T. The radio will save your selection and return to standby mode.

DCS Tone Signaling Frequency Table

DCS Code	DCS Code	DCS Code	DCS Code	DCS Code	DCS Code	DCS Code	DCS Code	DCS Code	DCS Code	DCS Code
023	054	125	165	245	274	356	445	506	627	732
025	065	131	172	246	306	364	446	516	631	734
026	071	132	174	251	311	365	452	523	632	743
031	072	134	205	252	315	371	454	526	654	754
032	073	143	212	255	325	411	455	532	662	
036	074	145	223	261	331	412	462	546	664	
043	114	152	225	263	332	413	464	565	703	
047	115	155	226	265	343	423	465	606	712	
051	116	156	243	266	346	431	466	612	723	
053	122	162	244	271	351	432	503	624	731	

If you choose the **IDCS tone code setting**, you will need to use the up or down buttons to select the desired tone code of 105 available. If you choose IDCS code 023, your display will read: **IDCS 023**

If you choose IDCS code 754, your display will read: **IDCS 754**

When the desired IDCS tone code appears on the display, select and set your choice by pressing the MODE button or the P-T. The radio will save your selection and return to standby mode.

IDCS Tone Signaling Frequency Table

IDCS Code	IDCS Code	IDCS Code	IDCS Code	IDCS Code	IDCS Code	IDCS Code	IDCS Code	IDCS Code	IDCS Code	IDCS Code
754	654	526	454	371	315	252	205	134	072	031
743	632	523	452	365	311	251	174	132	071	026
734	631	516	446	364	306	246	172	131	065	025
732	627	506	445	356	274	245	165	125	054	023
731	624	503	432	351	271	244	162	122	053	
723	612	466	431	346	266	243	156	116	051	
712	606	465	423	343	265	226	155	115	047	
703	565	464	413	332	263	225	152	114	043	
664	546	462	412	331	261	223	145	074	036	
662	532	455	411	325	255	212	143	073	032	

To set the **per-channel radio transmit output power**, press and release the MODE button, then the up or down buttons until **Ch SET** appears. Press the MODE button to select. Scroll through the sub-menu settings with the up or down buttons, press the MODE button when **TX POWER** appears. Settings include: **PWR Hi**
PWR Lo

You can toggle between these per-channel settings with the up or down buttons. When the desired setting appears on screen, press the MODE button to select. The radio will save your selection, and return to standby mode. The display will show an “H” or an “L” to confirm High (45 Watt) or Low (2 Watt) output power setting for the current channel.

To set the **normal scan list on/off setting**, press and release the MODE button then the up or down buttons until the **Ch SET** display appears. Press and release the MODE button again to select. Scroll through the sub-menu settings with the up or down buttons, press the MODE button when **Normal SCAN** appears on screen.

Normal SCAN appears. Settings include: **NSCAN ON**
NSCAN OFF

You can toggle between these settings with the up or down buttons. When the desired setting appears on screen, press the MODE button to select. The radio will save your On or Off selection for the current channel, and return to standby mode. **NOTE:** Your radio will only scan channels with the scan setting “On”.

To set the **Priority scan list on/off setting**, press and release the MODE button then the up or down buttons until the

Ch SET display appears. Press and release the MODE button again to select. Scroll through the sub-menu settings with the up or down buttons, press the MODE button when PRI SCAN appears on screen. Settings include: PSCAN ON and PSCAN OFF.

You can toggle between these settings with the up or down buttons. When the desired setting appears on screen, press the MODE button to select. The radio will save your On or Off selection for the current channel, and return to standby mode.

NOTE: This setting is linked to the Priority Scan sub-menu in the “System Option” menu, detailed following this section. “If Priority Scan option of “System Option” menu is on, Priority scan works only when the channel selector is positioned to the channel with “PSCAN ON” displayed.”

To set the **two-tone option**, press the MODE button then the up or down buttons until the Ch SET display appears. Press and release the MODE button again to select. Scroll through the sub-menu settings with the up or down buttons, press the MODE button when TWO TONE appears on screen. Settings include: INDIV, GROUP, SUPER GR.

You can toggle between these settings with the up or down buttons. When the desired setting appears on screen, press the MODE button to select. Next, toggle between On and Off status settings which occur for each above sub-menu.

Example: INDIV ON, GROUP OFF and SGRP ON.

When the desired setting appears on screen, press the MODE button to select. The radio will save your On or Off selection for the current channel and return to standby mode. **NOTE:** Individual, Group and Super Group frequencies and timing are programmed by your radio communications Dealer.

For quick reference, the next few pages detail the Channel Options Menu, sub-menus and their settings.

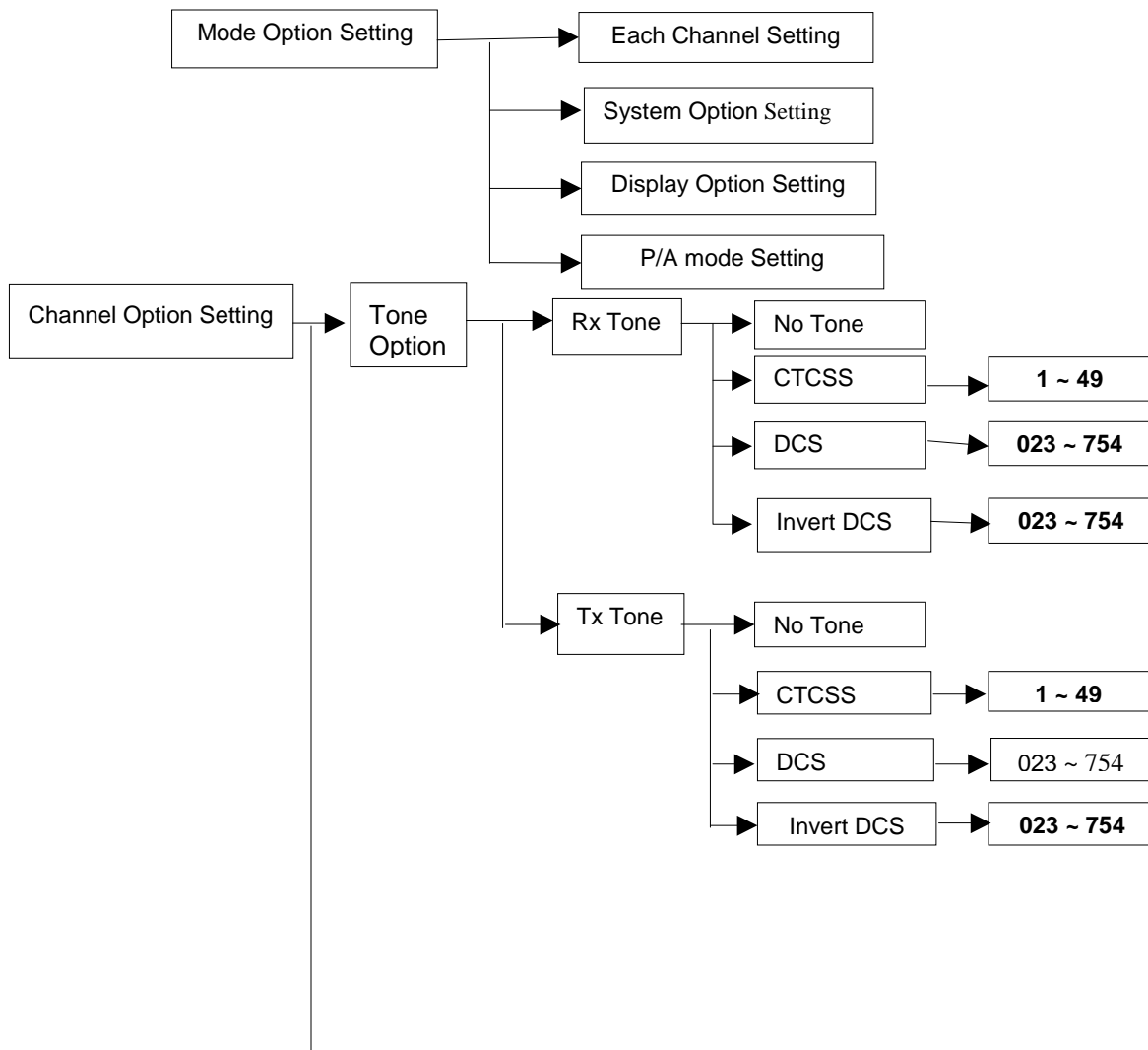

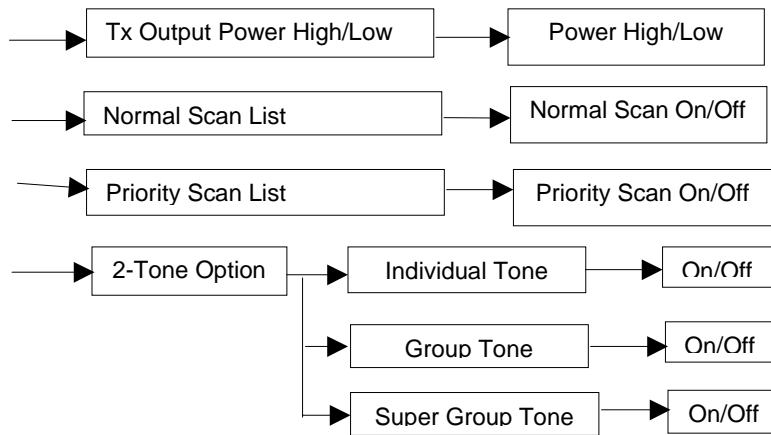

System Option Settings Menu

To enter the System Option Setting Menu, press and release the MODE button during the receive or standby mode, then use the up or down buttons until **SYSTEM** appears. Select the above option with a press and release of the MODE button.

(Beep Set, VOX (Voice Operated TX) Set, Time-Out-Timer Set, Penalty, Busy Channel Lockout Set, Marked Idle, Scan Set, Priority Scan, Transmit Delay, Power Save, Clear-To-Talk, Roger Beep, 2 tone alarm, Microphone Hook and Audio Comander). Details on sub-menu settings follow.

You can toggle between these settings with the up or down buttons. When the desired setting appears on screen, press the MODE button to select. If you choose the **Beep Set setting**, you will need to use the up or down buttons to choose

BEEP ON or **BEEP OFF**. When the desired setting appears on screen, press the MODE button to select. The radio will save your On or Off selection and return to standby mode.

If you choose the **VOX Set setting**, you will also need to choose between On or Off selections, by using the up or down buttons to choose, and the MODE button to select. If you choose On, you will need to choose a VOX level setting, which includes: **VOXL L1**, **VOXL L2** or **VOXL L3**. You can toggle between these VOX sensitivity level settings with the up or down buttons. When the desired setting appears on screen, press the MODE button. The radio will save your selection and return to standby mode.

If you choose the **Time-Out-Timer setting**, your choices include: **TOT ON** or **TOT OFF**. Toggle between the settings with the up or down buttons. When the desired setting appears on screen, press the MODE button. If you choose "On", you will need to choose the duration of the Time-Out-Timer setting, from 10 seconds to 990 seconds. Use the up or down buttons to toggle, until the desired number of seconds appears on the display. Use the MODE button to select. The radio will save your selection and return to standby mode. Example of display: **TOT 990**

NOTE: In the Time-Out-Timer sub-menu, if "Off" is selected by pressing the MODE button, the TOT function will be disabled, and the radio will return to standby mode.

If you choose the **Time-Out-Timer Penalty setting**, your choices include Penalty On or Off. Toggle between the settings with the up or down buttons. When the desired setting appears on screen, press the MODE button. If you choose "On", you will need to choose the duration of the Penalty setting, from 1 second to 100 seconds. Use the up or down buttons to toggle, then the MODE button to select the desired amount of time. The radio will save your selection and return to standby mode.

Example of display: **PNLT 100**.

NOTE: In the Time-Out-Timer Penalty sub-menu, if "Off" is selected by pressing the MODE button, the TOT Penalty function will be disabled, and the radio will return to standby mode.

NOTE: If the radio transmits in excess of the set time, it will beep an error tone and the radio will receive a signal, but will NOT transmit during the penalty time.

If you choose the **Busy Channel Lockout setting**, your choices include: **BCLD ON** or **BCLD OFF**. Toggle between the settings with the up or down buttons. When the desired setting appears on screen, press the MODE button. Your radio will save your On or Off selection and return to standby mode.

NOTE: If you select "On", and the channel is busy, it will inhibit transmission.

If you choose the **Marked Idle setting**, your choices include On or Off. Toggle between the settings with the up or down buttons. When the desired setting appears on screen, press the MODE button to select. The radio will save your selection and return to standby mode.

Example of display: **MARK ID**.

NOTE: If the channel is set by Busy Channel Lockout, and transmit is inhibited, Marked Idle allows a transmission when your CTCSS or DCS tone signal is received.

If you choose the **Scan Set setting**, your choices include: **SCAN MOD**, **SC SPEED**, **SC DELAY** and **LOOK BACK**. (Scan Mode, Scan Speed, Scan Delay and Lookback). You can toggle between these settings with the up or down buttons. When the desired setting appears on screen, press the MODE button to select. If you select **SCAN MOD**, your choices will include: **NSCAN TX**, **PSCAN TX**, **PSL SCAN** and **P-CH TX**. (Normal Scan Transmit, Priority Scan Transmit, Priority Select Scan and Priority Only TX Scan). You can toggle between these settings with the up or down buttons. When the desired setting appears on screen, press the MODE button to select. The radio will save your selection, and return to standby mode.

If you select the **Scan Speed setting**, you will need to choose the scan speed time, from 50 milliseconds to 500 milliseconds. Use the up or down buttons to select the desired speed, then the MODE button to select. The radio will save your selection and return to standby mode. Example of display: **SCP 50**.

NOTE: Scan speed time is the amount of time that scan stays on a channel (when there is no signal) before moving to the next channel on the scan list.

If you select the **Scan Delay setting**, you will need to choose the scan delay time, from 1 seconds to 30 seconds. Use the up or down buttons to select the desired time, then the MODE button to select. The radio will save your selection and return to standby mode. Example of display: **SCd 30**.

NOTE: Scan delay time is the standby time to remain on the channel after the receiving signal stops or after transmitting.

If you select the **Lookback setting**, you will need to choose the desired lookback frequency time, from 1 second to 10 seconds. Use the up or down buttons to select the desired time, then the MODE button to select. The radio will save your selection and return to standby mode. Example of display: **LBT 10**.

NOTE: In Priority Scan mode, Lookback time is the interval time to check the Priority Channel when the radio receives a signal on a non-priority channel.

If you choose the **Priority Scan setting**, your choices include Priority Scan On or Off settings. You can toggle between these settings with the up or down buttons. When the desired setting appears on the display, press the MODE button to select. If you choose the On setting, use the up or down buttons to select your desired Priority Scan channel, then the MODE button to select. The radio will save your On or Off setting, and return to standby mode.

Example of display: **PRICH-32**.

NOTE: In the Priority Scan setting mode, if the MODE or P-T-T buttons are pressed, Priority Scan will be disabled and the radio will return to standby mode.

If you choose the **TX Delay setting**, your choices include On or Off settings. You can toggle between these settings with the up or down buttons. When the desired setting appears on the display, press the MODE button to select. The radio will save your selection and return to standby mode. Example of display: **TDLY ON**.

NOTE: The TX Delay setting is used to remove the squelch tail from the receiving radio by creating a CTCSS turn-off (no tone) for 180 milliseconds after TX is completed.

If you choose the **Clear To Talk setting**, your choices include On or Off settings. You can toggle between these settings with the up or down buttons. When the desired setting appears on the display, press the MODE button

to select. The radio will save your selection and return to standby mode. Example of display: **CTT ON**.

NOTE: If you select On, the radio issues a beep tone when pressing the P-T-T button, letting you know that speaking may begin.

If you choose the **Roger Beep setting**, your choices include On or Off settings. You can toggle between these settings with the up or down buttons. When the desired setting appears on the display, press the MODE button to select. The radio will save your selection and return to standby mode.

An example of the Roger Beep display: **RGIP ON**.

NOTE: If you select On, the radio issues a beep tone after TX is completed to confirm the transmission has finished.

If you choose the **2 Tone Alarm setting**, your choices include On or Off settings. You can toggle between these settings with the up or down buttons. When the desired setting appears on the display, press the MODE button to select. The radio will save your selection and return to standby mode.

An example of the **2 Tone Alarm** display: **ALM ON**.

NOTE: If you select On, the radio issues an alarm tone after a 2 tone signal is decoded and RX carrier is no longer present if a call is received during the alarm the alarm will stop until the call is gone. Once the RX signal is no longer present the alarm will continue until the 2 tone decode is reset by pressing the AUX button for 3 seconds.

If you choose the **Microphone Hook setting**, your choices include On or Off settings. You can toggle between these settings with the up or down buttons. When the desired setting appears on the display, press the MODE button to select. The radio will save your selection and return to standby mode.

An example of the **Microphone Hook** display: **HOOB ON**.

NOTE: If you select On, the Microphone hub **will not** require ground to activate privacy tones.

If you choose the **Microphone Hook setting Off**, the Hook Scan setting will appear, your choices include On or Off settings. You can toggle between these settings with the up or down buttons. When the desired setting appears on the display, press the MODE button to select. The radio will save your selection and return to standby mode.

An example of the **Hook Scan** display: **HSCN ON**.

NOTE: If you select Microphone Hook setting Off, the Microphone hub **will** require ground to activate privacy tones if microphone hub is removed from ground privacy tones are defeated and the radio will operate in carrier squelch mode. If you select Hook scan On, your radio will continue to scan with the microphone hub not grounded in carrier squelch mode.

If you choose the **Audio Componder setting**, your choices include On or Off settings. You can toggle between these settings with the up or down buttons. When the desired setting appears on the display, press the MODE button to select. The radio will save your selection and return to standby mode.

An example of the **Audio Componder** display: **A-C ON**.

NOTE: If you select On the audio quality between wide and narrow band channels will be the same.

For quick reference, the next few pages detail the System Option Menu, sub-menus and their settings.

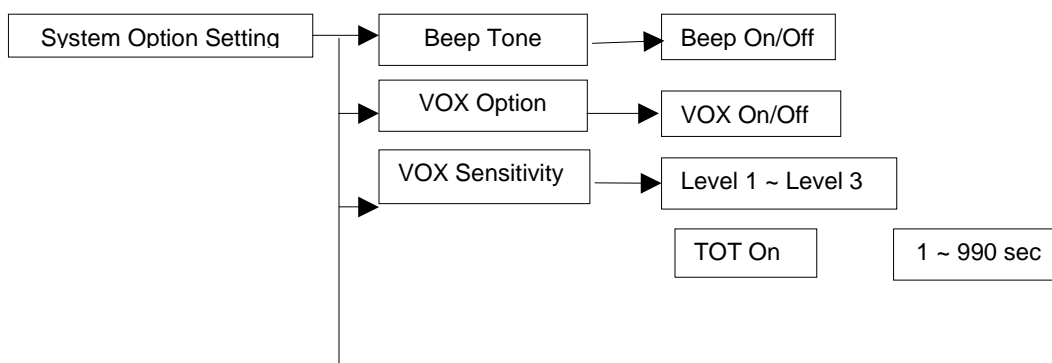

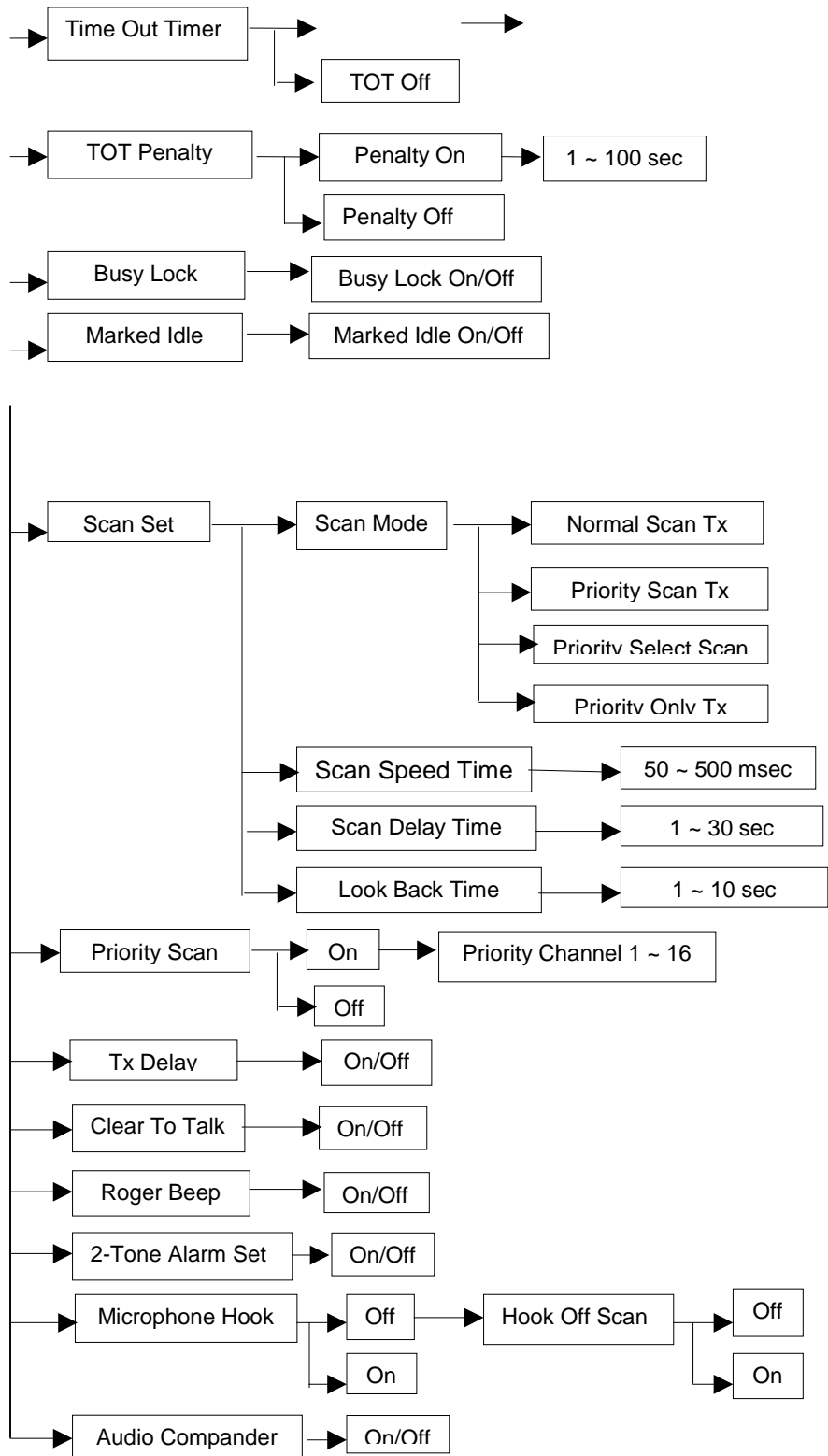

Display Option Settings Menu

With the radio powered on, select the desired channel. Press the MODE button and then the up or down buttons until **DISPLAY** appears. Press and release the MODE button to select. Sub-menu settings include: **[CH]DISP**

SLIDE ST BACK LGT

You can toggle between these settings with the up or down buttons. When the desired setting appears on screen, press the MODE button to select. If you select **CH DISP**, your choices will include: **NAME**, **CH No** and **FREQUENE** (Name, Channel Number and Frequency). You can toggle between these settings with the up or down buttons. When the desired setting appears on the display, press the MODE button to view the current information for that setting.

Example of Name display: **TOPAZ3**.

NOTE: The Name, Channel Number and Frequency settings are display-only settings. You can not change them within these screens.

If you select the **Slide Setting**, your choices include Slide On or Slide Off. Toggle between the settings with the up or down buttons. When the desired setting appears on screen, press the MODE button. Your radio will save your On or Off selection and return to standby mode. **NOTE:** If Slide Setting is On, and the radio is in standby for more than 1 minute, a slide message pre-programmed by your Dealer will scroll on screen.

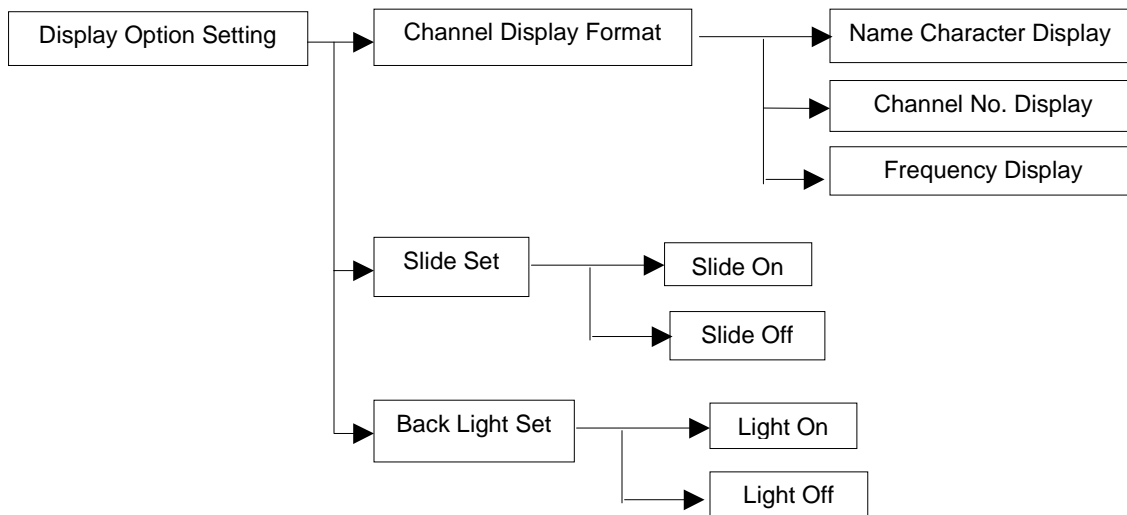

P/A Option Settings Menu

With the radio powered on press the MODE button and then the up or down buttons until **P/A SET** appears. Press and release the MODE button to select. To turn P/A mode off press the MODE button.

Example of P/A display: **P/A MODE**

ACC-733 DTMF Microphone Operation

The ACC-733 can be used for telephone interconnect or other DTMF applications. Consult your Dealer for other application possibilities.

The ACC-733 can be operated in an auto dial mode or manually operated and is back lighted for low light conditions.

A telephone ringer will be heard when a telephone connection has been established or for an incoming call.

Auto Dial Operation

Up to 16 digits can be dialed when using auto dial. Follow these steps to place a call using auto dial.

- A. Enter the desired number by pressing and releasing 0–9, * or # keys. The dialed numbers will appear in your radio display. # will be indicated as F in your display. Note: The # key is normally used to end, or hang up, an interconnect system. Consult your Dealer for exact system operation. The * key will be indicated as E.

- B. Press the SND key to send the dialed number.
- C. When the called party answers, press the P-T-T of the microphone to answer. Release the P-T-T to listen for a response.
- D. When the conversation has ended Press and hold the P-T-T of the microphone press and hold the # key for 1 or 2 seconds to end the call. Release the P-T-T when the call has ended.

Manual Dial Operation

- A. Press and hold the P-T-T of the microphone and enter the desired number by pressing and releasing 0 –9, * or # keys. The dialed numbers will appear in your radio display. # will be indicated as F in your display. Note: The # key is normally used to end, or hang up, an interconnect system. Consult your Dealer for exact system operation. The * key will be indicated as E.
- B. When dialing is complete release the P-T-T and wait for the called party to answer.
- C. When the called party answers, press the P-T-T of the microphone to answer. Release the P-T-T to listen for a response.
- D. When the conversation has ended Press and hold the P-T-T of the microphone press and hold the # key for 1 or 2 seconds to end the call. Release the P-T-T when the call has ended.

To Store a Number in Memory

- A. Dial the desired number. Entered number will show in the radio display.
- B. Press and release the STR key.
- C. Press and release any number 0 – 9, * and # to store the number.

To Recall a Stored number from Memory

- A. Press and release the RCL key.
- B. Press and release the number key from which a number has been stored.
- C. Press SND to dial the recalled number.

If a number has been accidentally recalled repeat steps A. and B. until the proper number has been recalled.

Clearing a Stored Number

- A. Press and release the RCL key.
- B. Press and release the number key from which a number has been stored. The stored number will show in the radio display.
- C. Press and hold the CLR key to remove the stored number. A new number can now be entered and stored in that location.

Clearing a Dialed Number

When a number has been accidentally entered during auto dial a press and release of the CLR key will delete an individual number. A press and hold of the CLR key will clear the entire dialed number.

Licensing and Service Information

FCC Licensing

The Federal Communications Commission requires the operator of this radio be properly licensed under the applicable Part and/or Parts of the FCC Rules and Regulations.

Consult your radio communications Dealer or contact the nearest FCC field office for information about obtaining a license.

Service

Do not tamper with internal adjustments. Damage to the equipment and/or improper operation may result. There are no serviceable components inside the radio.

It is recommended that you return your radio to a qualified radio communications Dealer for any service or repairs.

Maintenance

Your Legacy radio is designed to be maintenance free. To keep it in good working condition:

- Clean external surfaces with a clean cloth dampened in a solution of dishwasher detergent diluted in water. Apply the solution sparingly to avoid any moisture leaking into cracks and crevices. DO NOT submerge the radio. Use a non-metallic brush, if necessary, to dislodge stubborn particles. Dry the surface thoroughly with a soft, lint free cloth.
- DO NOT use solvents or spirits for cleaning – they may permanently damage the housing.

Software Copyrights, Warranty Statement

Software Copyrights

The Topaz3 / Legacy products described in these operating instructions may include copyrighted Topaz3 / Legacy software programs stored in semi-conductor memories or other media. Laws in the United States and other countries preserve for Topaz3 / Legacy certain exclusive rights for copyrighted software programs, including the exclusive right to copy or reproduce in any form the copyrighted software program.

Accordingly, the copyrighted Topaz3 / Legacy software programs contained in the Topaz3 / Legacy product(s) described in this operating instruction manual may not be copied or reproduced without the express written permission of Topaz3, LLC.

Furthermore, the purchase of Topaz3 / Legacy products shall not be deemed to grant either directly or by implication, estoppel, or otherwise, any license under the copyrights, patents or patent applications of Topaz3, LLC, except for normal non-exclusive, royalty-free license to use that arises by operation of law in the sale of a product.

Topaz3 / Legacy Product Warranty

Topaz3, LLC (hereinafter, "Topaz3") warrants that the Products and included accessories sold herein will be free from defects in workmanship or materials under normal use and service for a period of two (2) years (one year for accessories) from the date of purchase by the original end user, provided that the buyer has complied with the requirements stated herein. This warranty is offered to the initial end user and is not assignable or transferable. Topaz3 is not responsible for any ancillary equipment which is attached to or used in conjunction with Topaz3 / Legacy products.

If the Product fails to function under normal use because of manufacturing defect(s) or workmanship during the two (2) years period following the date of purchase, it will be replaced or repaired at Topaz3's option at no charge when returned to the place of purchase. The defective unit must be accompanied by proof of the date of purchase in the form of a sales receipt.

The sole obligation of Topaz3 hereunder shall be to replace or repair the Product covered in this Warranty. Replacement, at Topaz3's option, may include a similar or higher-featured product. Repair may include the replacement of parts or boards with functionally equivalent reconditioned or new parts or boards. Replaced parts, accessories, batteries, or boards are warranted for the balance of the original time period. All replaced parts, accessories, batteries or boards become the property of Topaz3.

Topaz3 shall have no obligation to make repairs or to cause replacement required through normal wear and tear or necessitated in whole or in part by catastrophe, fault or negligence of the user, improper or unauthorized alterations or repairs to the Product, use of the Product in a manner for which it was not designed, or by causes external to the Product. This warranty is void if the serial number is altered, defaced or removed.

The user is responsible for the payment of any charges or expenses incurred for the removal of the defective product from the vehicle or site of its use, for the transportation of the product to the place of repair, for the return of the repaired / replaced product to the site of its use and for the reinstallation of the product.

THE EXPRESS WARRANTIES CONTAINED HEREIN ARE IN LIEU OF ALL OTHER WARRANTIES, EITHER EXPRESSED OR IMPLIED OR STATUTORY, INCLUDING, WITHOUT LIMITATION, ANY WARRANTY OF MERCHANTABILITY OR FITNESS FOR A PARTICULAR PURPOSE.

FOR ANY PRODUCT WHICH DOES NOT COMPLY WITH THE WARRANTY SPECIFIED, THE SOLE REMEDY WILL BE REPAIR OR REPLACEMENT. IN NO EVENT WILL TOPAZ3 BE LIABLE TO THE BUYER OR ITS CUSTOMERS FOR ANY DAMAGES, INCLUDING ANY SPECIAL, INCIDENTAL, INDIRECT OR CONSEQUENTIAL DAMAGES, OR FOR THE LOSS OF PROFIT, REVENUE OR DATA ARISING OUT OF THE USE OF OR THE INABILITY TO USE THE PRODUCT.

This warranty is void for sales and deliveries outside of the U. S. A.

**Topaz3, LLC
10828 NW Air World Drive
Kansas City, Missouri 64153
www.topaz3.com
Toll free: 800-821-7848
Phone: 816-891-6320 • Fax: 816-891-8815**

Printed in Korea

P/N: 680-090-xxxx