



**Miele@home**  
**Manual for**  
**EI8800-A and EI7800**  
**USA/CDN Market**  
**Version 1.2**

## Revision History

Date	Version	Description	Author	Department
09.09.2014	1.0 Draft	Initial manual for FCC/IC	F. Laube	GTE/SKT
23.09.2014	1.1	Final manual IC Statement in France Technical data update	F. Laube	GTE/SKT
29.09.2014	1.2	Added RF Parameter Power Radiated Test Report 6-0196-12- 1-2b Clause 5.5	F. Laube	GTE/SKT

## Reviewed By

Date	Version	Name	Department
09.09.2014	1.0 Draft	G. Borgelt	GTE/TL
23.09.2014	1.1	G. Borgelt	GTE/TL
29.09.2014	1.2	G. Borgelt	GTE/TL

## Approvals

Date	Version	Name	Department

## Contents

1. General	4
2. Technical data	4
3. Norms / Standards	5
3.1 FCC / IC	5
3.2 Safety	5
3.3 RF-Standard	5
3.4 Photos and Labels	5
4. Regulatory Notice	7
4.1 United States (FCC Notice)	7
4.2 Canada (IC Notice)	8

## 1. General

The EI7800 and EI8800-A are wireless network interface modules for Miele home appliances like hoods, hobs, cooling devices or washing machines. The modules are supporting the IEEE 802.15.4 ZigBee protocol. The EI8800-A is a module for build in appliances during manufacturing. The EI7800 is a wireless stick which is connected to the appliance by the customer or customer service.

Both modules depend on the same wireless design with a single chip transceiver. The EI7800 has additional components for power supply and UART driver.

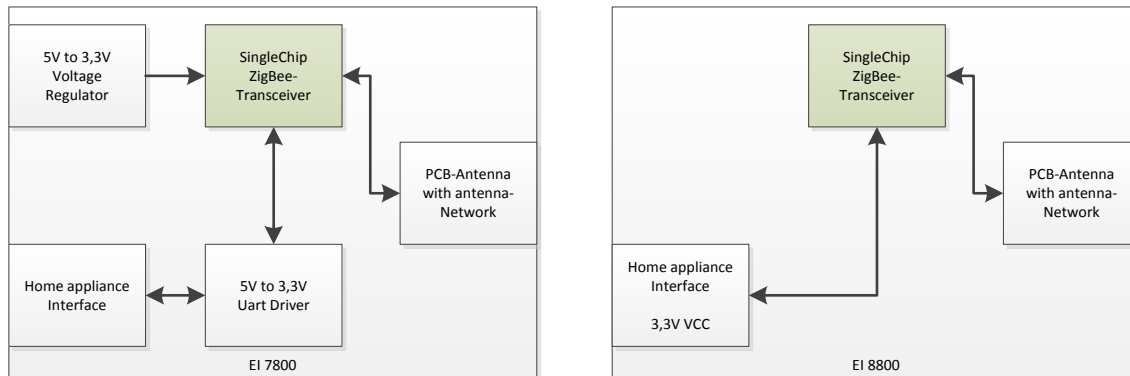

## 2. Technical data

VCC in V EI8800-A EI7800	3,3 5,0
Max. Current in mA EI8800-A EI7800	50
Current in A	0.06
ambient temperature in °C EI8800-A EI7800	0 – 85 0 - 50
Humidity max	93% non condensation
Dimensions in mm EI8800-A EI7800 Wire (EI8800)	30/27 82,5/40,0/23,5 325
<b>wireless</b>	
MCU/RF IC	CC2530
Antenna type	PCB inverted F
Crystal Input Clock in MHz	32
Frequency	2.4 GHz
Channels	11 - 26
Channel Frequencys	2,405 GHz – 2,480 GHz (5MHz distance)
Bandwidth	2,83 MHz
Transmission Power in mW	<8

### 3. Norms / Standards

#### 3.1 FCC / IC

FCC Regulation Part 15.109, Part 15.209 and Part 15.247  
IC regulations RSS-Gen Issue 3 and RSS-210 Issue 8

#### 3.2 Safety

UL 60730-1A, CAN/CSA E60730-1:02+A1:2007  
CSA Certificate 70009686

#### 3.3 RF-Standard

The modules use the RF standard IEEE 802.15.4.

#### 3.4 Photos and Labels

EI7800 product



EI7800 Internal



EI7800 Label side view

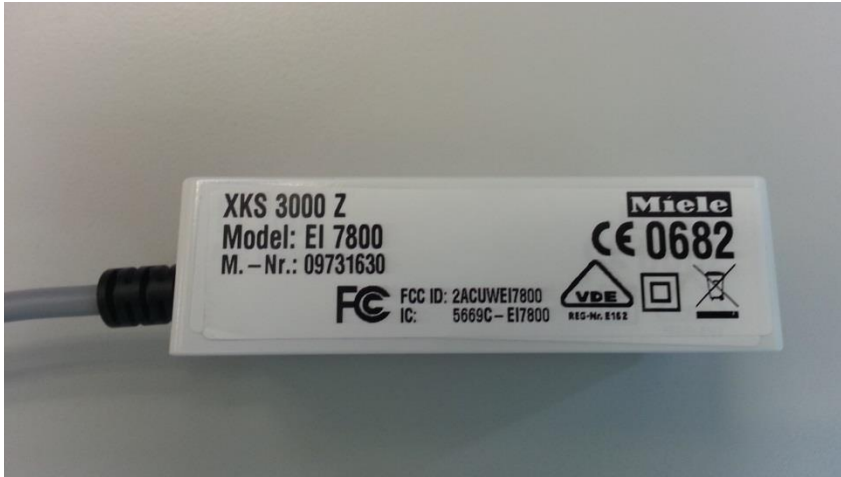

EI8800-A Top View



EI8800-A integrated in home appliance steering device

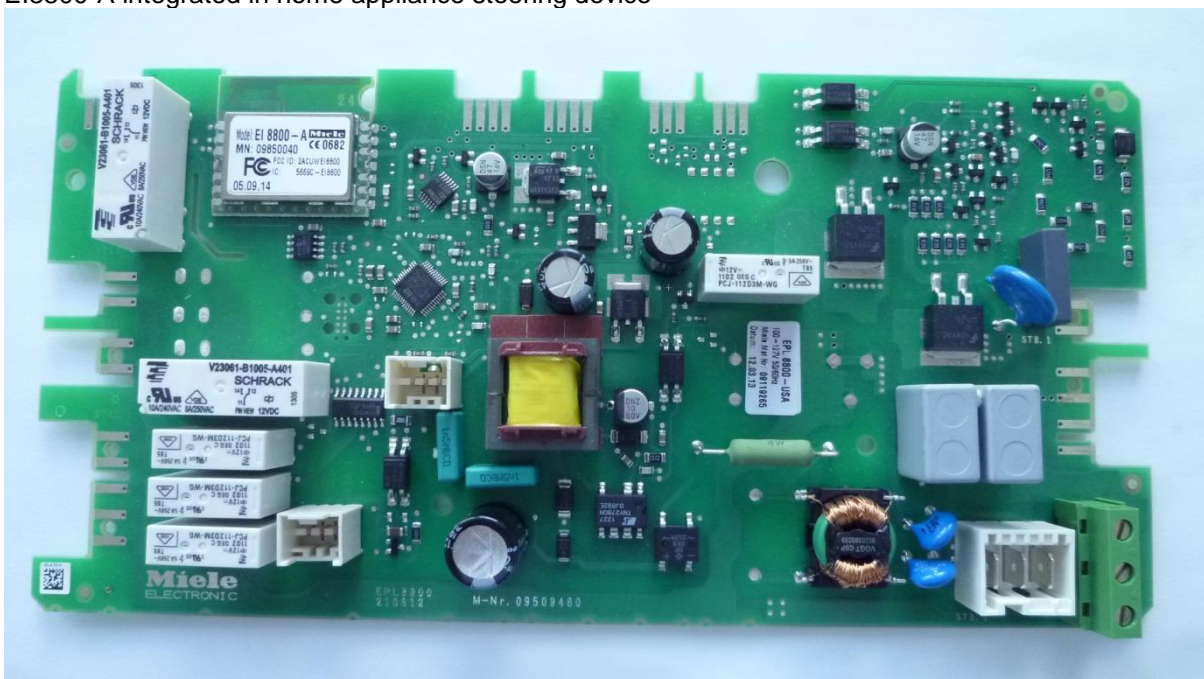

Manual for EI 7800/EI8800-A USA/CDN	Version: 1.2	
EI8800-A EI7800	Date: 29/09/2014	

## 4. Regulatory Notice

### 4.1 United States (FCC Notice)

**FCC ID: 2ACUWEI7800**

**FCC ID: 2ACUWEI8800**

In accordance with FCC Part 15, the 2ACUWEI8800 is listed as a Modular Transmitter Device.

#### FCC CAUTION:

Any changes or modifications not expressly approved by the party responsible for compliance could void the user's authority to operate the equipment.

This device complies with Part 15 of FCC Rules. Operation is Subject to following two conditions:

- (1) This device may not cause harmful interference, and
- (2) This device must accept any interference received including interference that cause undesired operation.

#### FCC STATEMENT:

This equipment has been tested and found to comply within the limits for a Class B digital device, pursuant to part 15 of the FCC Rules. These limits are designed to provide reasonable protection against harmful interference in a residential installation.

This equipment generates, uses, and can radiate radio frequency energy and, if not installed and used in accordance with the instructions, may cause harmful interference to radio communications.

However, there is no guarantee that interference will not occur in a particular installation. If this equipment does cause harmful interference to radio or television reception, which can be determined by turning the equipment off and on, the user is encouraged to try to correct the interference by one or more of the following measures:

- Reorient or relocate the receiving antenna
- Increase the separation between the equipment and receiver
- Connect the equipment into an outlet on a different circuit from that to which the receiver is connected
- Consult the dealer or an experienced radio/TV technician for help.

#### USERS MANUAL OF THE END PRODUCT:

The end user has to be informed that any changes or modifications not expressly approved by the manufacturer could void the user's authority to operate this equipment. If the size of the end product is smaller than 8x10cm, then additional FCC part 15.19 statement is required to be available in the user's manual: This device complies with Part 15 of FCC rules. Operation is subject to the following two conditions: (1) this device may not cause harmful interference and (2) this device must accept any interference received, including interference that may cause undesired operation.

#### LABEL OF THE END PRODUCT (only for EI8800-A):

The final end product must be labeled in a visible area with the following " Contains **FCC ID: 2ACUWEI8800** ". If the size of the end product is larger than 8x10cm, then the following FCC part 15.19 statement has to also be available on the label: This device complies with Part 15 of FCC rules. Operation is subject to the following two conditions: (1) this device may not cause harmful interference and (2) this device must accept any interference received, including interference that may cause undesired operation.

Manual for EI 7800/EI8800-A USA/CDN	Version: 1.2	
EI8800-A EI7800	Date: 29/09/2014	

#### 4.2 Canada (IC Notice)

**IC: 5669C-EI7800**

**IC: 5669C-EI8800**

The term "IC" before the radio certification number only signifies that Industry Canada technical specifications were met. Operation is subject to the following two conditions: (1) this device may not cause interference, and (2) this device must accept any interference, including interference that may cause undesired operation of the device.

This Class B digital apparatus complies with Canadian ICES-003.  
Cet appareil numérique de la classe B est conforme à la norme NMB-003 du Canada.

LABEL OF THE END PRODUCT (only EI8800-A):

The final end product must be labeled in a visible area with the following " Contains **IC : 5669C-EI8800**".

This device complies with Part 15 of the FCC Rules and with Industry Canada licence-exempt RSS standard(s). Operation is subject to the following two conditions: (1) this device may not cause harmful interference, and (2) this device must accept any interference received, including interference that may cause undesired operation.

Le présent appareil est conforme aux CNR d'Industrie Canada applicables aux appareils radio exempts de licence. L'exploitation est autorisée aux deux conditions suivantes: (1) l'appareil ne doit pas produire de brouillage, et (2) l'utilisateur de l'appareil doit accepter tout brouillage radioélectrique subi, même si le brouillage est susceptible d'en compromettre le fonctionnement.