

Miele

Operating and installation instructions

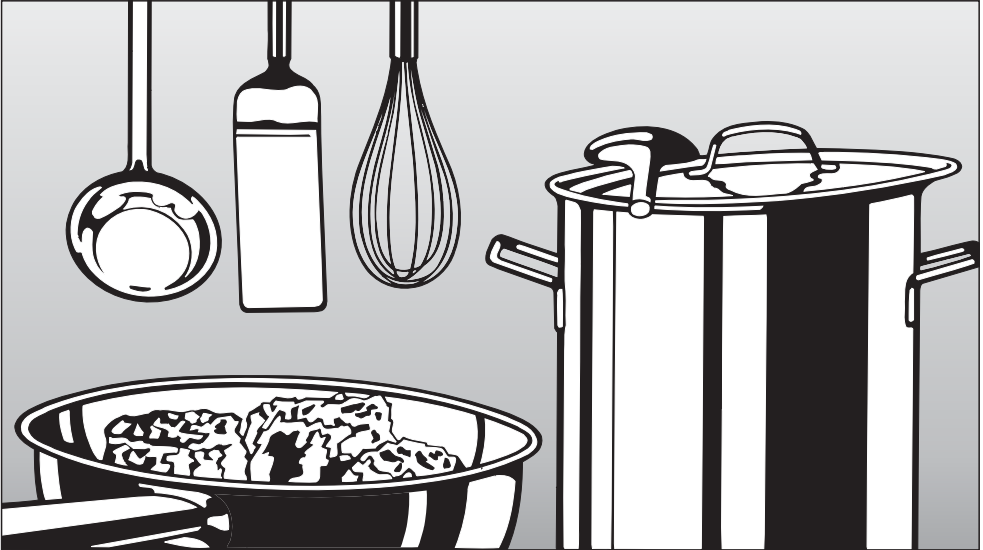

Gas hobs
KM 3034
KM 3054

To avoid the risk of accidents or damage to the appliance it is **essential** to read these instructions before it is installed and used for the first time.

en - GB

M.-Nr. 09 168 460

-
- GB** This appliance can be used in countries other than those specified on the appliance. It is, however, set up for connection to the gas and electricity supplies in the countries specified. For use in other countries please contact the Miele spare parts or customer service department in your country.
- D** Das Gerät ist auch für den Gebrauch in anderen als auf dem Gerät angegebenen Bestimmungsländer zugelassen. Die landesspezifische Ausführung und die Anschlussart des Gerätes haben wesentlichen Einfluss auf den einwandfreien und sicheren Betrieb. Für den Betrieb in einem anderen als auf dem Gerät angegebenen Bestimmungsland wenden Sie sich bitte an den für das Land zuständigen Kundendienst.
- E** El aparato está autorizado para el uso en países diferentes a los países de destino indicados. La ejecución específica para cada país y el tipo de conexión del aparato influyen de forma decisiva en el funcionamiento correcto y seguro. Para el funcionamiento en un país diferente al país de destino indicado en el aparato, consulte al Servicio Post-venta autorizado para el país.
- F** Cet appareil est également homologué dans des pays différents de ceux mentionnés sur l'appareil. Pour que l'appareil fonctionne parfaitement et en toute sécurité, il est important de disposer de l'exécution spécifique au pays et du type de raccordement approprié. Pour le fonctionnement dans un pays autre que celui spécifié sur l'appareil, veuillez vous adresser au service après-vente du pays où sera installé l'appareil.
- I** L'apparecchio può essere usato anche in paesi diversi da quello indicato sull'apparecchio stesso. Tuttavia, le varianti specifiche di un determinato paese e il tipo di allacciamento alla rete hanno un'importanza fondamentale per il suo sicuro e corretto funzionamento. Per questo se si vuole usare l'apparecchio in un paese diverso rivolgersi al servizio di assistenza tecnica Miele del paese in cui si intende usarlo.
- NL** Het apparaat is ook toegelaten voor gebruik in andere landen dan de landen die op het apparaat vermeld staan. De specifieke uitvoering en de aansluitwijze zijn van groot belang voor het goed en veilig functioneren. Neem daarom contact op met de Technische Dienst van de fabrikant in uw land als u het apparaat in een land wilt gebruiken dat niet op het apparaat vermeld staat.

Gas-heated appliances

Safety precautions to take if you smell gas

- Turn off the gas emergency control valve immediately.
This is usually located near the gas meter.
- Eliminate all sources of ignition in a safe manner.
Do not smoke, light cigarette lighters or matches.
- Do not operate electrical lights or switches, i.e. do not switch them "On" or "Off".
- Open all doors and windows to ventilate the area.
- If the smell of gas persists, evacuate the building.

In the UK you must now:

- Call the Gas Emergency Contact Centre (Tel: 0 800 111 999)

For any gas work in the UK always use a Gas Safe registered engineer.



In other countries please follow relevant country specific procedures on gas.

Contents

Description of the appliance	6
KM 3034.	6
KM 3054.	7
Accessories supplied	8
Warning and Safety instructions	11
Caring for the environment	19
Before using for the first time	20
Operation	21
Rapid ignition system	21
Controls	21
Switching on	22
Regulating the flame	23
Switching off	23
Easy switch-off function.	24
In-operation/residual heat indicator.	24
Minute minder	25
Setting the minute minder	25
Altering the time set for the minute minder	25
To cancel the time set for the minute minder	25
Allocating the minute minder to a specific cooking zone	26
Suitable pans	27
Combi insert	28
Wok ring	28
Energy saving tips	29
Safety features	30
Thermo-electric ignition	30
Safety switch-off.	30
System lock	30

Cleaning and care	31
Problem solving guide	35
Optional accessories	38
Safety instructions for installation	39
Building-in dimensions	42
Installation	44
Electrical connection	46
Gas connection	48
Burner ratings	50
Conversion to another type of gas	51
Jet table	51
To change the main jets	52
To change the small jets	54
Function test	55
After sales service, data plate, guarantee	56

Description of the appliance

KM 3034

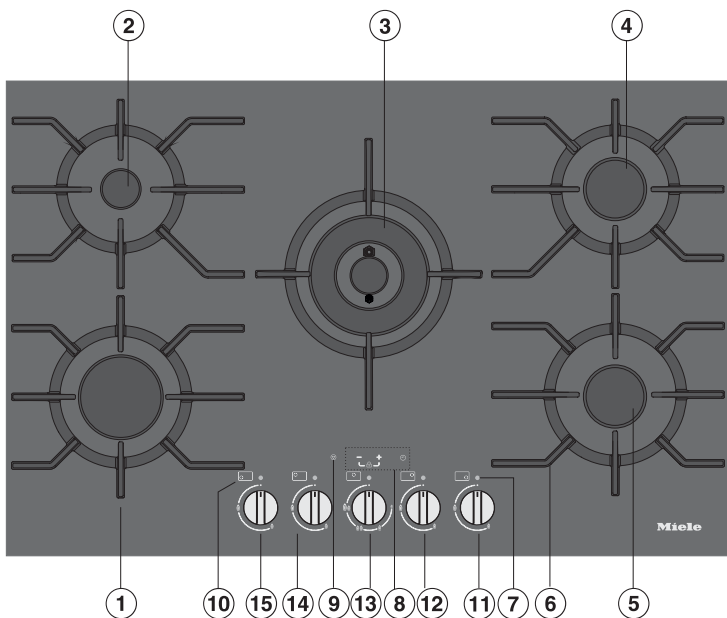

① Large burner

② Small burner

③ Wok burner

④ ⑤ Medium burners

⑥ Pan support (for each burner)

⑦ Residual heat indicator

⑧ Minute minder

⑨ Easy switch-off

⑩ Cooking zone symbol

Cooking zone controls:

⑪ Front right

⑫ Rear right

⑬ Middle

⑭ Rear left

⑮ Front left

Description of the appliance

KM 3054

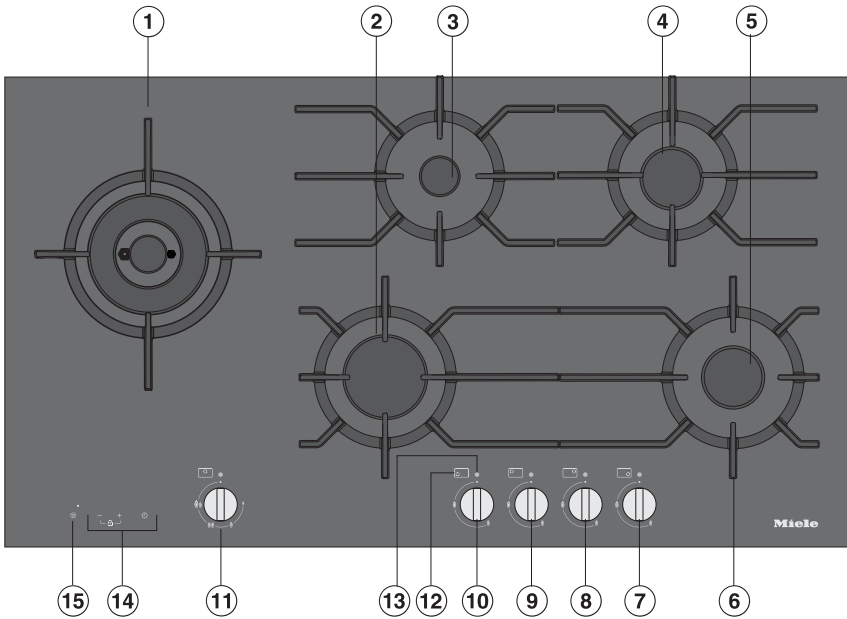

- ① Wok burner
- ② Large burner
- ③ Small burner
- ④ ⑤ Medium burners
- ⑥ Pan support (for each burner)

Cooking zone controls:

- ⑦ Front right
 - ⑧ Rear right
 - ⑨ Rear left
 - ⑩ Front left
 - ⑪ Left
- ⑫ Cooking zone symbol
 - ⑬ Residual heat indicator
 - ⑭ Minute minder
 - ⑮ Easy switch-off

Description of the appliance

Accessories supplied

The accessories supplied with your appliance as well as a range of optional ones are available to order from Miele (see "Optional accessories").

Wok ring

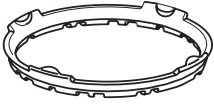

The Wok ring supplied with your appliance can be used in instances where extra stability is required. It is particularly suitable for Woks with a rounded base.

Combi insert for small pans



If you are using a pan which is smaller than recommended in the chart under "Pans", then the combi insert supplied should be used.

Minute minder display

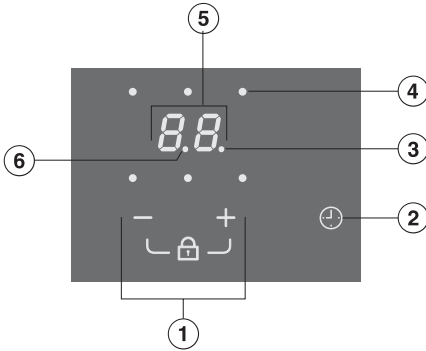

① Lock/Timer

② Sensor switch:

- Select minute minder
- Switch between timer functions
- Select cooking zone

③ Indicator lamp for minute minder

④ Indicator lamp for relevant zone, e.g. back right-hand cooking zone

⑤ Timer display

00 to *99* = Time in minutes

0.h to *5.h* = Time in hours

⑥ Indicator light for half hours with a minute minder time of more than 99 minutes

Description of the appliance

Burner

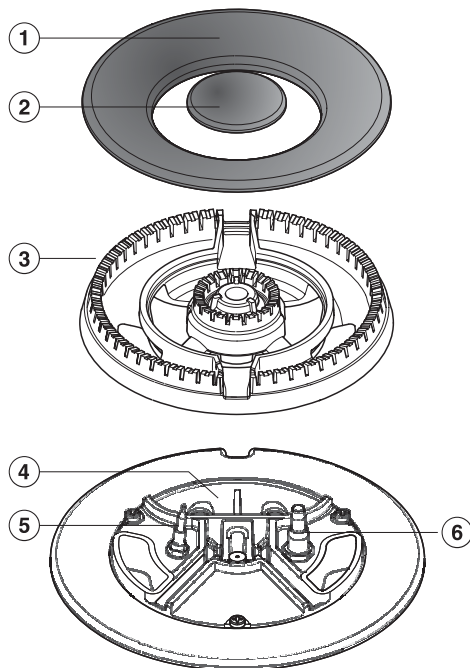

Wok burner

- ① Outer burner cap
- ② Inner burner cap
- ③ Burner head
- ④ Burner base
- ⑤ Ignition safety device
- ⑥ Ignitor

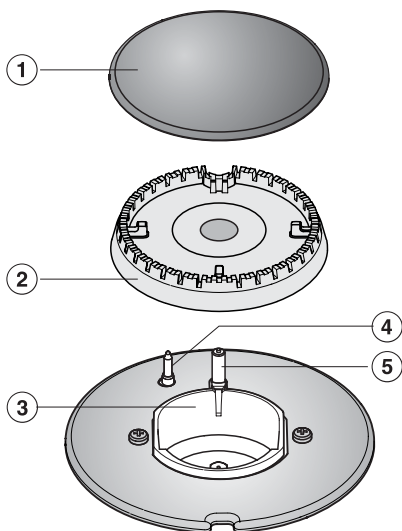

Small, medium and large burners

- ① Burner cap
- ② Burner head
- ③ Burner base
- ④ Ignition safety device
- ⑤ Ignitor

Warning and Safety instructions

This appliance complies with all relevant local and national safety requirements. Inappropriate use can, however, lead to personal injury and damage to property.

To avoid the risk of accidents and damage to the appliance, please read these instructions carefully before installation and before using it for the first time. They contain important notes on installation, safety, use and maintenance.

Keep these instructions in a safe place and ensure that new users are familiar with the content. Pass them on to any future owner.

Correct application

- ▶ This gas hob is not designed for commercial use. It is intended for use in domestic households and in similar working and residential environments.
- ▶ The appliance is intended for domestic use only to cook food and keep it warm.
Any other use is not supported by the manufacturer and could be dangerous. Miele cannot be held liable for damage resulting from incorrect or improper use or operation.
- ▶ The gas hob is not intended for outdoor use.
- ▶ This appliance can be used by children aged from 8 years and above and by people with reduced physical, sensory or mental capabilities, or lack of experience and knowledge, if they are supervised whilst using it, or have been shown how to use it in a safe way and understand the hazards involved.

Warning and Safety instructions

Safety with children

- ▶ Activate the safety lock to ensure that children cannot switch on the appliance inadvertently.
- ▶ This appliance is not a toy! To prevent the risk of injury, do not allow children to play with the appliance or its controls.
- ▶ Children under 8 years of age must be kept away from the hob unless they are constantly supervised.
- ▶ Children 8 years and older may use the appliance only if they have been shown how to use it in a safe way and understand the hazards involved.
- ▶ The appliance and its accessible parts get hot when in use and remain hot for quite a while after being switched off. Keep children well away from the appliance until it has cooled down and there is no danger of burning.
- ▶ Do not store anything which might arouse a child's interest in storage areas above or next to the hob. Otherwise they could be tempted into climbing onto the appliance with the risk of burning themselves.
- ▶ Keep all pans out of reach of children. Turn pan handles inwards away from the edge of the hob. Danger of burning or scalding. Special hob guards are available from good retail outlets.
- ▶ Packaging, e.g. cling film, polystyrene and plastic wrappings, must be kept out of the reach of babies and young children. Danger of suffocation. Dispose of or recycle all packaging safely as soon as possible.

Technical safety

▶ Before installation, check the appliance for visible signs of damage. Do not install and use a damaged appliance. A damaged appliance may be dangerous.

▶ The electrical safety of this appliance can only be guaranteed if correctly earthed. It is most important that this basic safety requirement is observed and tested regularly, and where there is any doubt, the household wiring system should be inspected by a qualified electrician. Miele cannot be held liable for the consequences of an inadequate earthing system (e.g. electric shock).

▶ Before connecting the appliance to the mains electricity supply, make sure that the data quoted on the data plate match the household mains supply, otherwise the appliance could be damaged. Consult a qualified electrician if in any doubt.

▶ For safety reasons, this appliance may only be used after it has been built in.

▶ Connection to the gas supply must be carried out by a suitably qualified and competent person in strict accordance with current local and national safety regulations, e.g. a **Gas Safe** registered technician in the U.K.



If the appliance is supplied without a plug, or if the plug is removed, it must be connected to the mains electricity supply by a suitably qualified and competent electrician in strict accordance with current local and national safety regulations. The manufacturer cannot be held liable for damage caused by incorrect installation or connection.

Warning and Safety instructions

- ▶ Never open the outer casing of the appliance. Tampering with electrical connections or components and mechanical parts is highly dangerous to the user and can cause operational faults.
- ▶ Installation, maintenance and repairs may only be carried out by a suitably qualified and competent person in strict accordance with current national and local safety regulations.
Repairs and other work by unqualified persons could be dangerous. Miele cannot be held liable for unauthorised work.
- ▶ During installation, maintenance and repair work, the appliance must be disconnected from the gas supply and mains electricity supply. It is only completely isolated from the electricity supply when:
 - the mains fuse is disconnected, or
 - the screw-out fuse is removed (in countries where this is applicable), or
 - it is switched off at the isolator, or it is switched off at the wall socket and the plug is withdrawn from the socket.
- ▶ While the appliance is under guarantee, repairs should only be undertaken by a service technician authorised by Miele. Otherwise the guarantee is invalidated.
- ▶ Faulty components must only be replaced by genuine Miele original spare parts. The manufacturer can only guarantee the safety of the appliance when Miele replacement parts are used.
- ▶ The hob is not intended for use with an external timer switch or a remote control system.
- ▶ If the connection cable is damaged, it must be replaced by a suitably qualified electrician with a special connection cable of type H 05 V V-F (pvc insulated), available from the Miele Spare Parts Department.

Warning and Safety instructions

- ▶ Do not connect the appliance to the mains electricity supply by a multi-socket adapter or an extension lead. These do not guarantee the required safety of the appliance (e.g. danger of overheating).
- ▶ Do not use the hob if it is faulty, or if the ceramic surface is cracked, chipped or damaged in any way. Switch it off immediately, and disconnect it from the mains electricity supply and the gas supply. Call the Service Department.
- ▶ In areas which may be subject to infestation by cockroaches or other vermin, pay particular attention to keeping the appliance and its surroundings in a clean condition at all times. Any damage which may be caused by cockroaches or other vermin will not be covered by the guarantee.

Correct use

- ▶ The appliance gets hot when in use and remains hot for quite a while after being switched off. There is a danger of burning until the residual heat indicators go out.
- ▶ If a cooker hood is installed above the gas hob, ensure that the burners are always covered with a pan when in use. Otherwise flames could reach the cooker hood, parts of which could then be damaged or set on fire.
- ▶ Do not leave the appliance unattended whilst it is being used. Oil and fat are potential fire hazards as they can ignite if overheated.
- ▶ If oil or fat does catch fire, do not attempt to put out the flames with water. Use a suitable fire blanket, saucepan lid, damp towel or similar to smother the flames.
- ▶ Do not use the appliance to heat up the room. Due to the high temperatures radiated, objects near the appliance could catch fire. The life of the appliance could also be reduced.

Warning and Safety instructions

- ▶ Do not flambé under a cooker hood. The flames could set the cooker hood on fire.
- ▶ For added protection, it is advisable to use heat-resistant pot holders or gloves when using the appliance. Ensure that they do not come into contact with the flames. Do not use large cloths, tea towels or similar as the ends could touch the flames and catch fire. Take care not to let the gloves get damp or wet, as this causes heat to transfer through the material more quickly with the risk of scalding or burning yourself.
- ▶ Do not drop anything on the ceramic surface. Even a light object could cause damage in certain circumstances.
- ▶ Do not use the appliance as a resting place for anything else. The article could melt or catch fire if residual heat is still present or if the appliance is switched on by mistake.
- ▶ Do not cover the hob with, e. g. with a hob cover, a cloth or protective foil. This could present a fire hazard if the appliance is switched on by mistake or if the hob is still warm.
- ▶ Do not use plastic or aluminium foil containers. These melt at high temperatures and could catch fire.
- ▶ Do not heat up unopened tins of food on the hob as pressure will build up in the tin, causing it to explode. This could result in injury and scalding or damage.
- ▶ Make sure all the components of the gas burners have been correctly assembled before switching on.
- ▶ Pans must be the correct size for the burner they are used on (see "Suitable pans"). A pan which is too small will be unstable on the pan support. If the pan diameter is too large, flames can spread out to the sides and damage or burn the worktop, wall claddings or surrounding units and also parts of the hob. Miele cannot be held liable for this type of damage.

Warning and Safety instructions

- ▶ Ensure that the flames from the burner do not spread out beyond the base and up the sides of the pan.
- ▶ Unless the pan manufacturer states that you can do so, do not use pans with very thin bases on this hob, and never heat up empty pans as they could get damaged. This could damage the appliance.
- ▶ The pan supports supplied must always be used. Pans must not be placed directly on the burner.
- ▶ Do not store any inflammable objects near the gas hob.
- ▶ Remove splashes of fat and other food debris from the surface as soon as possible. These are a fire hazard.
- ▶ Replace the pan supports carefully to avoid scratching the surface of the hob.
- ▶ Using a gas hob results in the build-up of heat, moisture and combustion products in the room in which it is installed. To ensure that there is adequate ventilation, especially when the appliance is in use: make sure natural ventilation to the room is not hindered or use a mechanical ventilation device (e.g. a cooker hood).
- ▶ Intensive and prolonged use of the appliance may result in a requirement for additional ventilation, e.g. opening a window or a more effective form of mechanical ventilation, e.g. use of a cooker hood on a higher setting.
- ▶ When using the gas hob an extractor hood or an on-site ventilation device must be used.
- ▶ When using an electrical appliance, e.g. a hand-held food blender, near the gas hob, ensure that the cable of the electrical appliance does not come into contact with the hot appliance. The insulation on the cable could become damaged, giving rise to an electric shock hazard.

Warning and Safety instructions

- ▶ Spray canisters, aerosols and other inflammable substances must not be stored in a drawer under the hob. Cutlery inserts must be heat-resistant.
- ▶ Always ensure that food is sufficiently cooked or reheated. Some foods may contain micro-organisms which are only destroyed by thorough cooking at a sufficiently high temperature for long enough. Therefore, when cooking or reheating food such as poultry, it is particularly important that the food is completely cooked through. If in doubt, select a longer cooking or reheating time.
- ▶ Do not use pans that are large enough to cover more than one burner. The resulting build-up of heat could damage the appliance.
- ▶ If the appliance is installed behind a kitchen furniture door, it may only be used with the furniture door open. Do not close the door whilst the hob is in use or whilst there is any residual heat left in the appliance.
- ▶ If the appliance has not been used for a longer period of time it should be thoroughly cleaned before it is used again. It is also advisable to have the appliance tested for safety.

Miele cannot be held liable for damage caused by non-compliance with these Warning and Safety instructions.

Disposal of the packing material

The transport and protective packing has been selected from materials which are environmentally friendly for disposal, and should be recycled.

Ensure that any plastic wrappings, bags, etc. are disposed of safely and kept out of the reach of babies and young children. Danger of suffocation.

Disposal of your old appliance

Electrical and electronic appliances often contain materials which, if handled or disposed of incorrectly could be potentially hazardous to human health and to the environment. They are, however, essential for the correct functioning of your appliance. Please do not therefore dispose of it with your household waste.

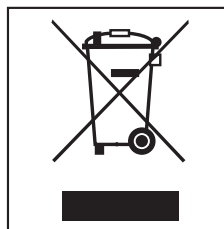

Please dispose of it at your local community waste collection/recycling centre or contact your dealer for advice. Ensure that it presents no danger to children while being stored for disposal.

Before using for the first time

Please stick the extra data plate for the appliance supplied with this documentation in the space provided in the "After sales service, data plate" section of this booklet.

Cleaning for the first time

- Remove any protective foil.
- Clean all removable parts of the burners with a solution of warm water and a little washing-up liquid applied with a soft sponge. Dry all parts thoroughly after cleaning and then reassemble the burners (see "Cleaning and care").
- Before using for the first time, clean the appliance with a damp cloth only and then wipe dry.

The metal components have a protective coating which may give off a slight smell when heated up for the first time.

The smell and any vapours given off do not indicate a faulty connection or appliance, and they are not harmful to health.

Rapid ignition system

The appliance has a rapid ignition system with the following features:

- Rapid ignition without pressing and holding the control dial
- Automatic re-ignition

If the flame is extinguished by a draught, etc. the burner is automatically reignited. If reignition is unsuccessful, the gas supply is automatically cut off (see "Thermoelectric ignition safety device")

Controls

The control is used to ignite the burner and to regulate the strength of the flame.

Small, medium and large burners

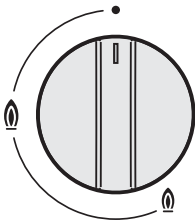

- The gas supply is turned off
- 🔥 Strongest flame
- 🔥 Weakest flame

Wok burner

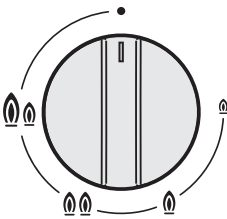

- The gas supply is turned off
- 🔥🔥 Strongest flame:
The inner and outer burners operate at the highest setting.
- 🔥 Strong flame:
The outer burner operates at the lowest setting, the inner burner at the highest setting
- 🔥 Weak flame:
The outer burner is switched off, the inner burner operates at the highest setting
- 🔥 The weakest flame:
The outer burner is switched off, the inner burner operates at the lowest setting

Operation

Switching on

When using the gas hob an extractor hood or a ventilation device must be used.

- The control for the burner required must be pressed in and turned anti-clockwise to the largest flame symbol to switch on. The ignitor will make a clicking sound and ignite the gas.

When a control is operated, a spark is produced on all cooking zones. This is not a fault.

- If the burner does not ignite, turn the control to off "●". Air the room or wait at least 1 minute before trying again.
- If the burner does not ignite the second time, turn the control to "●", and see "Problem solving guide".

When switching on, re-ignition sometimes occurs (1-2 clicks) if the flame on the ignition safety device has gone out briefly, or if the thermal element is not hot enough, e.g. following a gust of air.

Regulating the flame

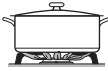

Regulate the flame so that it does not spread out beyond the sides of the pan. As the outer part of the flame is much hotter than the centre, the tips of the flames should stay beneath the pan base. Flame tips which extend beyond the sides of the pan merely warm up the air in the room and can also damage pan handles and increase the risk of injury.

The burners can be regulated at any level between the strongest and weakest flame.

Switching off

- Turn the control clockwise to position "●" .

This stops the flow of gas and the flame goes out.

Do not turn the control past the "●" position.

Operation

Easy switch-off function

All active cooking zones can be switched off by touching the easy switch-off sensor .

- Touch the  sensor.

The in-operation/residual heat indicators for active cooking zones will flash.

A minute-minder time set will continue to run down, if it is not allocated to a specific cooking zone. If it is allocated to a specific cooking zone, it will be cancelled.

The control light for the easy switch-off function is lit up until all active burner control dials are turned to "●".

In-operation/residual heat indicator

The in-operation/residual heat indicator lights up when the hob is switched on and remains lit during operation. If the appliance is switched off, the indicator light goes out briefly then lights up again as long as residual heat remains.

Do not touch or place any heat sensitive objects on the gas hob while the residual heat indicator is still on. Danger of burning and fire.

If the display is flashing, there is a fault. See section "Problem solving guide".

You can select a time from 1 minute (01) to 6 hours (6h). If a time of more than 99 minutes (99) is set, the time is set in half-hour steps. The half hour is indicated by a dot after the number.

Use the - sensor to reduce the time from 6.h to 00, and the + sensor to increase the time from 00 to 6.h. The display stops at 2.h and at 99. To continue entering the setting, briefly remove your finger from the sensor, and then touch it again.

When the set time has elapsed, 00 will appear in the timer display for a few seconds. An audible tone will sound at the same time. To turn the audible tone off before this, touch the ⊖ sensor.

The minute minder can be allocated to a specific cooking zone.

Setting the minute minder

- Touch the ⊖ sensor.

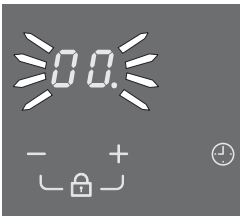

00 and the minute minder indicator lamp will flash in the timer display.

- Touch the - or + sensor until the time you require appears in the display, e.g. 15 minutes.

The time set will then count down in minutes. The time remaining will be shown in the timer display.

Altering the time set for the minute minder

- Touch the ⊖ sensor.
- Touch the - or + sensor to set the time you want.

To cancel the time set for the minute minder

- Touch the ⊖ sensor.
- Touch the - and + sensors at the same time.

Minute minder

Allocating the minute minder to a specific cooking zone

You can set the minute minder for any active cooking zone. All cooking zones can be programmed at the same time.

- Switch on the desired cooking zone.
- Touch the ⊖ sensor.

⏸ and the minute minder indicator lamp will flash in the timer display.

- Touch the ⊖ sensor again.

The minute minder indicator lamp in the timer display will go out and one of the cooking zone indicator lamps will flash.

- If several cooking zones are switched on, touch the ⊖ sensor repeatedly until the indicator lamp flashes for the cooking zone you wish to use this function for, e.g. back right, flashes.

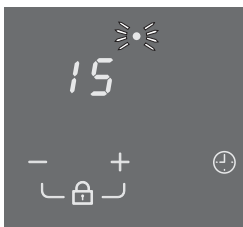

The indicator lights for the cooking zones which are switched on light up anti-clockwise, starting with the front right.

- Touch the - or + sensor until the time you require appears in the display, e.g. 15 minutes.

The time set will then count down in minutes. The time remaining will be shown in the timer display.

To set a switch-off time for a further cooking zone, proceed as above.

If more than one switch-off time is programmed, the shortest time remaining will show in the display, and the corresponding indicator lamp will flash. All the other indicator lights will light up constantly. If you want to check on the time remaining for another zone, touch the ⊖ sensor repeatedly until the indicator lamp for the zone you require flashes.

Suitable pans

Burner	Min. pan base diameter in cm
Small burner	10
Medium burner	12
Large burner	14
Wok burner	14
Max. diameter at top of pan in cm	
Small burner	20
Medium burner	22
Large burner	24
Wok burner	26

- Refer to the chart above and ensure that the pan diameter falls within the minimum and maximum diameters given for the burner you are using. A pan which is too small will be unstable on the pan support. If the pan base diameter is too large, flames can spread out to the sides and damage or burn the worktop, wall claddings or surrounding units and also parts of the hob. The manufacturer cannot be held liable for this type of damage.
- Remember when purchasing new pans that manufacturers usually refer to the diameter at the top of the pan in their documentation.
- Any heat-resistant pans can be used.
- Pans with thick bases are preferable as these distribute heat more evenly. With thin bases, there is a danger of food overheating in places. Stir the food frequently.
- Select pans which are suitable for the burner they are to be used on. In general: use larger diameter pans on the large burners, and smaller diameter pans on the small burners.
- Always place pans on the pan support supplied. Pans must not be placed directly on the burner.
- Place pans securely on the pan rest to minimise the risk of tipping.
- Do not use pots or pans with bases with pronounced edges or ridges, e.g. cast iron pans.



Suitable pans

Combi insert

The combi insert **must** be utilised when using pans with a base diameter of less than the minimum given in the table above. The combi insert ensures that the pan will sit securely on the hob, and cannot tip up.

Wok ring

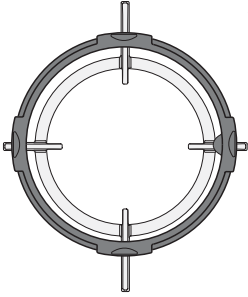

The Wok ring supplied with your appliance can be used in instances where extra stability is required. It is particularly suitable for Woks with a rounded base.

Make sure that the wok ring is securely in position to prevent it from slipping.
(See diagram).

Woks are a special type of pan. They have a small base diameter and large top diameter, generally between 35 - 40 cm. The wok burner is therefore particularly suitable for the wok.

Energy saving tips

- Use a pan lid whenever possible to minimise heat loss.
- Cook with as little water as possible.
- Cooking times are greatly reduced when using a pressure cooker.
- Turn the flame down promptly to a lower setting when the pan has come to the boil.
- Wide, shallow pans are preferable to tall, narrow ones. They will heat up faster.

Safety features

Thermo-electric ignition

This appliance is has a thermo-electric ignition safety device. If the flame goes out, for example if food has boiled over or if there is a sudden draught, and automatic re-ignition has been unsuccessful, the supply of gas to the burner will be cut off preventing any further escape of gas.

- To use the burner again, turn the control clockwise to the "●" position, and then switch it back on as normal.

Safety switch-off

If a burner has been used for an unusually long period (approx. 6 hours), it will switch off automatically.

- To use the burner again, turn the control clockwise to the "●" position, and then switch it back on as normal.

System lock

The system lock is set with the hob switched off. When activated, the hob cannot be switched on and the timer cannot be used.

If the system lock is activated, the control lamps light up and **LL** appears in the minute minder display when a sensor field is touched or a control is turned.

The safety lock is deactivated if there is a power cut.

Activating

- Simultaneously touch the - and + sensors, until **LL** appears in the minute minder display and a signal tone sounds.

Deactivating

- Touch the - and + sensors at the same time.

 Do not use a steam cleaning appliance to clean this appliance. The steam could reach electrical components and cause a short circuit.

- The appliance should be cleaned after each use. Allow the appliance to cool down to a safe temperature before cleaning.
- To avoid water marks and limescale deposits, use a soft cloth to dry surfaces that have been cleaned with water.
- Stubborn soiling should be soaked first.
- Food which boils over onto the hot hob can cause the burner components to discolour. **Remove any soiling immediately.**
- The surfaces of the burner components will become more matt with time. This is quite normal and will not affect the operation of the hob.

To avoid damaging the surface of your appliance, do not use:

- cleaning agents containing soda, alkalines, ammonia, acids or chlorides,
- cleaning agents containing descaling agents,
- stain or rust removers,
- abrasive cleaning agents, e.g. powder cleaners and cream cleaners,
- solvent-based cleaning agents,
- dishwasher cleaner,
- grill and oven cleaners,
- glass cleaning agents,
- hard, abrasive brushes or sponges, e.g. pot scourers, or sponges which have been previously used with abrasive cleaning agents,
- sharp pointed objects
(these can damage the seal between the frame and the worktop)

Cleaning and care

	Cleaning	Instructions
Ceramic surface	<p>Wipe all coarse soiling off using a damp cloth. Stubborn soiling may need to be removed with a shielded scraper blade.</p> <p>Clean with Miele ceramic glass and stainless steel cleaner (see "Optional Accessories"), or with another proprietary ceramic glass cleaner and kitchen roll or a clean soft cloth.</p> <p>Do not put cleaning agent onto a hot hob as this can cause staining.</p> <p>Wipe with a damp cloth then dry off with a soft cloth.</p>	<p>Do not use washing-up liquid as this will not remove all soiling and deposits. It will form an invisible coating which will cause permanent discolouration of the ceramic surface which cannot be removed.</p> <p>When using a proprietary ceramic glass cleaning agent, always follow the manufacturer's instructions.</p>
Pan supports	<p>Remove the pan supports.</p> <p>Wash them in the dishwasher or with a sponge and warm water with a little washing-up liquid.</p> <p>If necessary, you could use the scouring pad on the reverse of a washing-up sponge.</p>	
Controls	<p>With a sponge and warm water with a little washing-up liquid.</p>	<p>Not dishwasher proof.</p>
Burners	<p>Remove all loose parts of the burner.</p> <p>Wash them with a sponge and warm water with a little washing-up liquid</p> <p>Wipe all the non-removable burner parts with a damp cloth.</p>	<p>Not dishwasher proof.</p> <p>Make sure that the flame slits are completely dry after cleaning.</p>
Ignitors Ignition safety devices	<p>Wipe carefully with a well wrung-out damp cloth.</p>	<p>Do not let the ignitor get wet. If it gets wet it will not spark.</p>

To assemble the small, medium and large burners

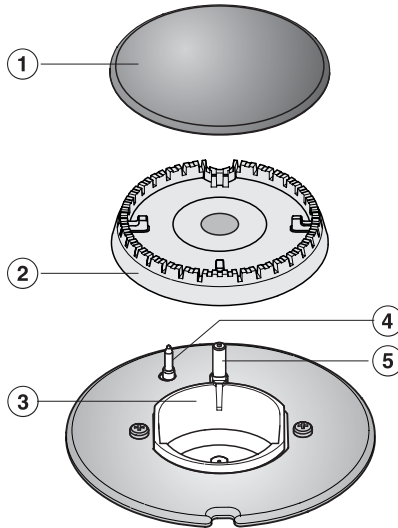

- Place the burner head ② on to the burner base ③ so that the ignition safety device ④ and the ignitor ⑤ extend through their respective holes in the burner head. The burner head must click into place correctly.
- Place burner cap ① flat over burner head ②. When correctly positioned it will not slide about.

Important: replace parts in the correct order after cleaning.

Cleaning and care

To assemble the wok burner

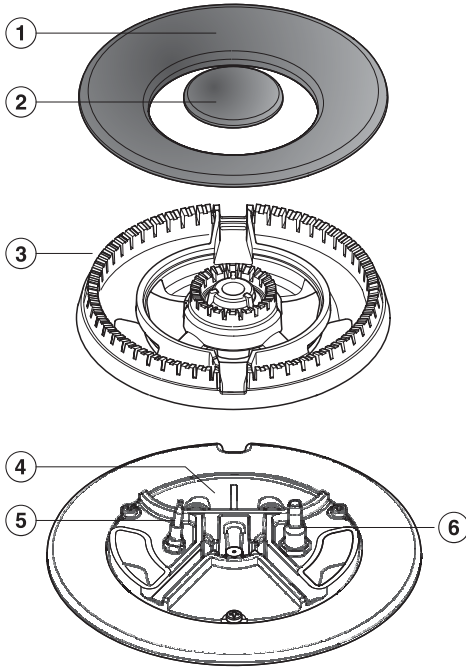

- Place burner head ③ onto burner base ④ so that the ignition safety device ⑤ and the ignitor ⑥ extend through their respective holes in the burner head. The burner head must click into place correctly.
- Place the burner caps ① and ② in position.

Important: replace parts in the correct order after cleaning.

Problem solving guide

With the help of the following notes, minor faults in the performance of the appliance, some of which may result from incorrect operation can be put right without contacting the Service Department, saving you both time and money.

The following guide may help you to find the reason for a fault, and to correct it. You should, however, note the following:

 Repairs to the gas and electrical components of this appliance must only be carried out by a suitably qualified and competent person to ensure safety (**Gas safe** registered in the UK). Repairs and other work by unqualified persons could be dangerous. The manufacturer cannot be held liable for unauthorised work.

Problem solving guide

Problem	Possible cause	Remedy
The burner does not ignite when the hob is being used for the first time or after a long period of not being used.	There could be an air lock in the gas pipe.	You may need to make several attempts before the burner ignites successfully.
The burner does not ignite after several attempts.		Turn all the controls clockwise to the "●" position and disconnect the appliance from the electricity supply for a few seconds.
	The burner is not correctly assembled.	Assemble the burner correctly.
	The gas supply tap is turned off.	Turn on the gas supply tap.
	The burner is wet or dirty.	Clean and dry the burner.
	The flame slits are blocked and/or wet	Clean and dry the flame slits.
If there is a power cut during operation		Turn all the controls clockwise to the "●" position. You can then operate the appliance as normal when power is restored.
The gas flame goes out after ignition	The flames are not touching the ignition safety device, it is not hot enough: - The burner is not correctly assembled. - There is dirt on the ignition safety device	Assemble the burner correctly. Remove any soiling.
The flame pattern has changed	The burner is not correctly assembled.	Assemble the burner correctly.
	The burner head or burner cap holes are dirty.	Remove any soiling.
The flame goes out during operation	The burner is not correctly assembled.	Assemble the burner correctly.
	Power cut.	Turn all the controls clockwise to the "●" position. You can then operate the appliance as normal when power is restored.
The operation/residual heat displays for active cooking zones will flash.	Power cut.	Turn all the controls clockwise to the "●" position. You can then operate the appliance as normal when power is restored.

Problem solving guide

Problem	Possible cause	Remedy
The ignitor on the burner does not spark.	Check whether the mains fuse has tripped.	If it has, contact a qualified electrician or the Miele Service Department.
	<ul style="list-style-type: none"> - Food residues between the ignitor and the burner cap. - Food residues on the ignition safety device 	Remove any soiling. Please see "Cleaning and care" for details.
The following fault messages appear in the display. <i>LC</i>	The system lock is activated.	Deactivate the system lock (see "Safety lock / System lock").
<i>FL</i>	Sensor fault	<p>Make sure that there is no direct light (from the sun or from an artificial source) falling onto the hob and that the surrounding area is not too dark.</p> <p>Make sure that there is nothing covering the sensors or the hob. Take any pans off the hob and wipe away any food deposits.</p> <p>Interrupt the power supply to the hob for approx. 1 minute.</p> <p>If this does not solve the problem, please call the Miele Service department.</p>
<i>F2</i> (The in-operation/residual heat indicator is flashing)	The overheating protection mechanism has triggered.	Turn all the controls clockwise to position "●". The hob can be used again when <i>F2</i> has gone out.
<i>E0</i> (The in-operation/residual heat indicator is flashing)	Electronic fault	Reset: Touch the easy switch-off sensor for 3 seconds. If the problem persists, please contact the Miele Service department.
All other fault codes	There is an electronic fault.	<p>Interrupt the power supply to the hob for approx. 1 minute.</p> <p>If the problem persists after reconnecting the appliance to the power supply, please contact the Miele Service department.</p>

Optional accessories

Miele offer a comprehensive range of useful accessories as well as cleaning and conditioning products for your appliance.

These products can be ordered online:



or from Miele (see back cover for contact details)

Ceramic and stainless steel hob cleaner **250 ml**



Removes heavy soiling, limescale deposits and aluminium residues.

E-cloth (microfibre cloth)

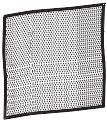

Removes finger marks and light soiling.

Safety instructions for installation

Fit the wall units and extractor hood before fitting the hob to avoid damaging the surface.

- ▶ The veneer or laminate coatings of worktops (or adjacent kitchen units) must be treated with 100 °C heat-resistant adhesive which will not dissolve or distort. Any backmoulds must be of heat-resistant material.
- ▶ This appliance must not be used in a non-stationary location (e.g. on a ship).
- ▶ An electric fryer must not be installed directly next to a gas hob, as the gas flames could ignite the fat in the fryer. It is essential to maintain a distance of at least 300 mm between these two appliances.
- ▶ A gas hob may not be built in over a fridge, fridge freezer, freezer, dishwasher, washing machine or tumble dryer.
- ▶ Ensure that the gas pipe and electrical cable are installed in such a way that they do not touch any parts of the appliance which become hot. This could cause damage.
- ▶ The electrical cable (and a flexible gas connection pipe in countries where applicable) must be installed in such a way so that they do not come into contact with any moving kitchen parts (e.g. a drawer), and cannot become trapped.
- ▶ Observe carefully the safety distances given on the following pages.

▶ Do not use any sealant except where expressly instructed to do so. The seal underneath the appliance provides a sufficient seal for the worktop.

All dimensions in this instruction booklet are given in mm.

Installation area

The room where the gas hob is to be installed must have

- A minimum capacity of 25.2 m³
- At least one externally-opening door or window
- An extractor hood or a controlled ventilation system (not recirculation), which has a minimum capacity of 189 m³/h
- suitable air inlets.

Safety instructions for installation

Safety distance above the appliance

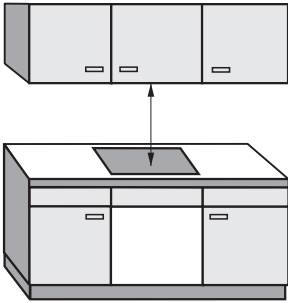

A minimum safety distance must be maintained between the appliance and the cooker hood above it. See the cooker hood manufacturer's operating and installation instructions for details. If the manufacturer's instructions are not available for the cooker hood, a minimum safety distance of at least 760 mm must be maintained.

For any flammable objects, e.g. utensil rails, wall units etc. a minimum distance of at least 760 mm must be maintained between them and the appliance below.

When two or more appliances are installed together below a cooker hood, e.g. a gas hob and an induction hob combiset, which have different safety distances given in the installation instructions, you should select the greater distance of the two.

Safety instructions for installation

Safety distances to the sides of and behind the appliance

Ideally the hob should be installed with plenty of space on either side. There may be a wall at the rear or a tall unit or wall on one side (right **or** left) (see illustrations).

The following minimum distances should be adhered to for safety reasons:

- ① Minimum distance of 50 mm **at the back** of the worktop cut-out to the rear edge of the worktop.
- ② Minimum distance of 150 mm to the **right** of the worktop cut-out to the nearest piece of furniture (e.g. tall unit).
- ③ Minimum distance of 150 mm to the **left** of the worktop cut-out to the nearest piece of furniture (e.g. tall unit).

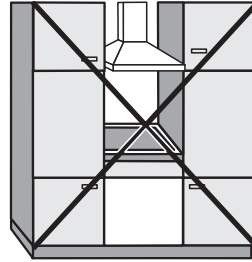

Not allowed

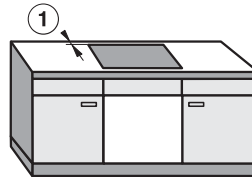
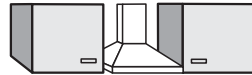

Recommended

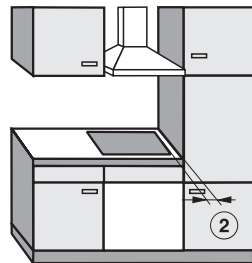

Not recommended

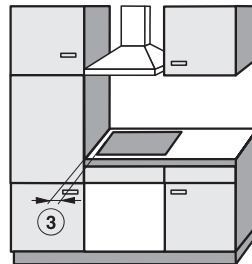

Not recommended

KM 3054

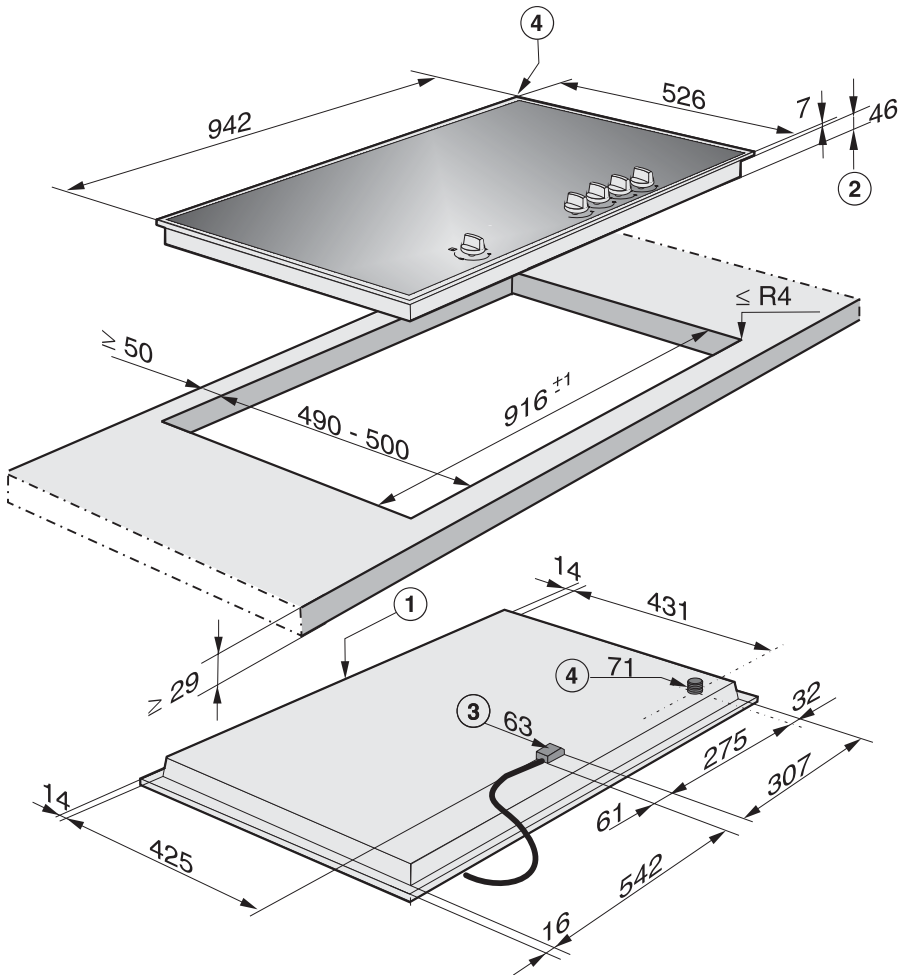

- ① Front
- ② Casing depth
- ③ Casing depth including mains connection box
- ④ Gas connection R 1/2 - ISO 7-1 (DIN 10226)

Installation

- Make the worktop cut-out according to the dimensions given in the building-in dimension diagram. Remember to maintain the **minimum safety distances** (see "Safety instructions for installation").
- Seal the cut surfaces on wood/laminated worktops with a suitable heat-resistant sealant to avoid swelling caused by moisture.

Make sure that the sealant does not come into contact with the top of the worktop.

- Feed the connection cable down through the cut-out.
- Place the hob in the cut-out without securing it.

If the corners of the frame are not flush with the worktop surface, the corner radius ($\leq R4$) can be carefully scribed to fit.

- Connect the hob to the mains (see "Electrical connection").
- Connect the appliance to the gas supply (see "Gas connection").

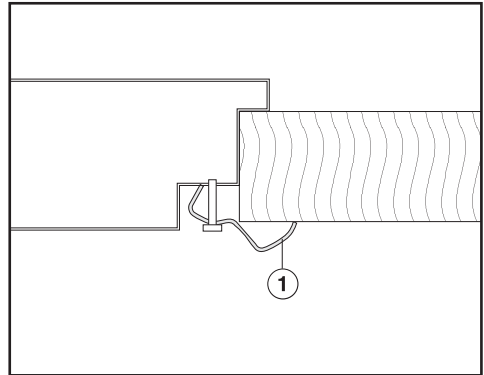

- Secure the appliance using the brackets supplied ①.

After installation

Check that all the burners are operating correctly.

The flame must not go out on the lowest setting, or when the control is turned quickly from a high to a low setting.

On the highest setting, the flame must have a distinctive and visible core.

Seal between appliance and worktop

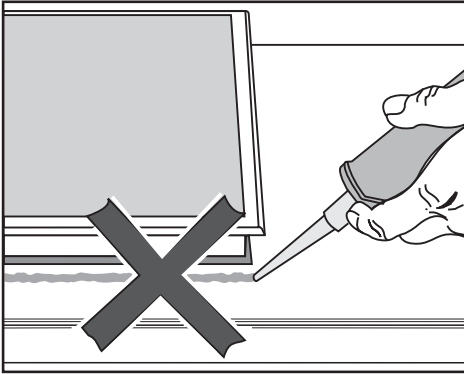

The sealing strip under the edge of the top part of the appliance provides a sufficient seal for the worktop.

The appliance must not be sealed with sealant (e.g. silicone). This could result in damage to the appliance or the worktop if the appliance ever needs to be removed for servicing.

Tiled worktop

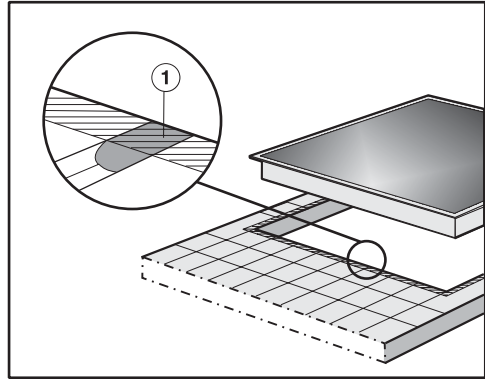

Grout lines ① and the hatched area underneath the hob frame must be smooth and even. If they are not the hob will not sit flush with the worktop and the sealing strip underneath the hob will not provide a good seal between the hob and the worktop.

Electrical connection

All electrical work should be carried out by a suitably qualified and competent person, in strict accordance with current local and national safety regulations (BS 7671 in the UK).

Installation, repairs and other work by unqualified persons could be dangerous. The manufacturer cannot be held liable for unauthorised work.

Ensure power is not supplied to the appliance until after installation or repair work has been carried out.

The appliance must only be operated when built-in. This is to ensure that all electrical parts are shielded. Live parts must not be exposed.

Do not connect the appliance to the mains electricity supply by an extension lead. These do not guarantee the required safety of the appliance.

Please make sure that the connection data quoted on the data plate match the household mains supply.

Connection should be made via a suitable isolator or a double pole fused spur connection unit which complies with national and local safety regulations and the on/off switch should be easily accessible after the appliance has been built in.

If the switch is not accessible after installation (depending on country) an additional means of disconnection must be provided for all poles.

For extra safety it is advisable to protect the appliance with a suitable residual current device (RCD).

When switched off there must be an all-pole contact gap of 3 mm in the isolator switch (including switch, fuses and relays).

Important UK

This appliance is supplied for connection to a single phase 230 V 50 Hz supply with a 3-core cable.

The wires in the mains lead are coloured in accordance with the following code:

Green/yellow = earth

Blue = neutral

Brown = live

WARNING
THIS APPLIANCE MUST BE
EARTHED

Important

The electrical safety of this appliance can only be guaranteed if correctly earthed. It is most important that this basic safety requirement is observed and regularly tested and where there is any doubt, the electrical wiring in the home should be tested by a qualified electrician. The manufacturer cannot be held liable for the consequences of an inadequate earthing system such as an electric shock.

If the connection cable is damaged, it must be replaced by a suitably qualified electrician with a special connection cable of type H 05 V V-F (pvc insulated), available from the Miele Service Department.

The manufacturer cannot be held liable for damage which is the direct or indirect result of incorrect installation or connection.

Gas connection

 Connection to the gas supply, or conversion from one type of gas to another, should only be undertaken by an approved and registered gas installer in strict accordance with local and national safety and building regulations (e.g. Gas Safe registered in the UK).

Every appliance should have its own easily accessible isolating valve and test point.

Check with your local gas supplier about the type of gas and its calorific value and compare this information with the type of gas quoted on the hob data plate.

This appliance is not connected to an exhaust flue. Please ensure it has adequate ventilation after installation.

The installer is responsible for ensuring that the appliance functions correctly when installed.

Depending on country, the hob is supplied ready for connection to natural or liquid gas (refer to label on the appliance).

United Kingdom:
GB II 2 H 3+ 20 mbar, 28-30/37 mbar

Ireland:
IE II 2 H 3+ 20 mbar, 28-30/37 mbar

Depending on country, a set of jets for conversion to an alternative type of gas may be included with the hob.

Please contact your dealer or the Miele Spare Parts Department for the appropriate conversion jets if necessary.

Conversion to another type of gas is described under "Conversion to another type of gas".

For any gas work in the UK always use a Gas Safe registered engineer.



Connection

The gas connection must be installed so that connection can be made either from inside or outside the kitchen unit, and the isolating valve must be easily accessible and visible (by opening one of the kitchen doors, if necessary).

After installing the appliance the gas burners have to be set for local conditions.

When the gas hob has been installed, it is essential to check that neither the gas pipe nor the electricity cable is in contact with hot parts of the appliance or hot gas exhaust, otherwise heat damage to the pipe and cable could occur.

A test for possible leakages must be carried out after installation.

Safety regulations demand that a pressure test point is installed near a gas hob to allow an engineer to test the pressure, following servicing.

The appliance is supplied with an R 1/2" - ISO 7-1 (DIN EN 10226) gas connection point.

An appropriate rigid connection and isolating valve must be installed for final connection.

The gas connection must be so sited that it is not adversely heated when the appliance is in operation.

Using a 90° angle

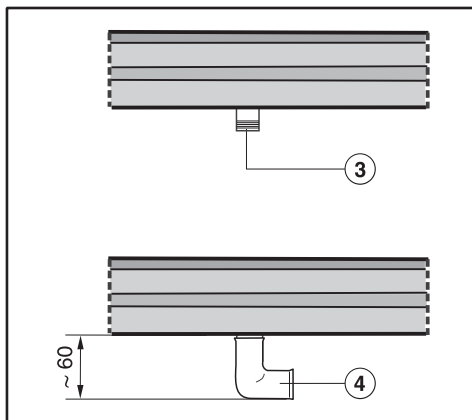

③ Gas connection R 1/2 - ISO 7-1 (DIN 10226)

④ 90° angle

Using a 90° angle will increase the building-in depth in the area of the gas connection by approx. 60 mm.

Burner ratings

Nominal rating

KM 3034 / KM 3054

Burner	Gas type	High setting		Low setting
		kW	g/h	kW
Small burner	Natural gas H	1.0	-	0.25
	Liquid gas	0.95	69	0.20
Medium burner	Natural gas H	1.7	-	0.30
	Liquid gas	1.7	124	0.35
Large burner	Natural gas H	2.7	-	0.50
	Liquid gas	2.55	186	0.60
Wok	Natural gas H	4.7	-	0.30
	Liquid gas	4.6	335	0.40
Total	Natural gas H	11.80		
	Liquid gas	11.50	837	

Conversion to another type of gas

 Connection to the gas supply, or conversion from one type of gas to another, should only be undertaken by an approved and registered gas installer in strict accordance with local and national safety and building regulations (e.g. **Gas Safe** registered in the UK).

When converting to a different type of gas, the main burner jets and the small burner jets have to be changed.

Jet table

	Main jet \varnothing	Small jet \varnothing
Natural gas H		
Small burner	0.76	0.39
Medium burner	0.94	0.42
Large burner	1.20	0.54
Wok burner	2x 1.07 / 0.72	0.42
Liquid gas		
Small burner	0,52	0.23
Medium burner	0.66	0.36
Large burner	0.81	0.42
Wok burner	2x 0.70 / 0.46	0.25

The jet markings refer to 1/100 mm of the jet diameter.

Conversion to another type of gas

Changing the jets

Disconnect the gas hob from the mains electricity supply.
Turn off the gas supply.

To change the main jets

Small, medium and large burners

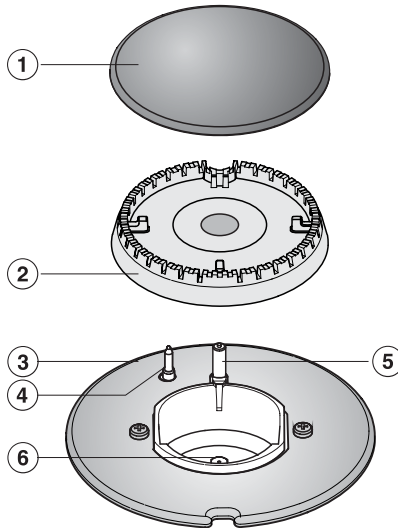

- Remove the pan support, burner cap ① and burner head ②.
- Using an M7 socket spanner, unscrew the main jet ③
- Fit the correct jets securely (see jet table).
- Finally, secure the jets against inadvertent loosening with sealing wax.

Conversion to another type of gas

Wok burner

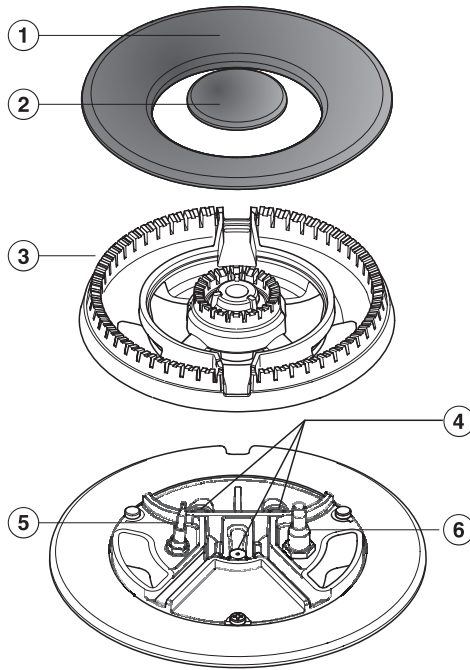

- Remove burner cap ①② and burner head ③.
- Using an M7 socket spanner, unscrew the main jet ④
- Fit the correct jets securely (see jet table).
- Finally, secure the jets against inadvertent loosening with sealing wax.

Conversion to another type of gas

To change the small jets

To change the small jets, the burner securing screws must first be loosened and the upper section of the appliance removed.

- Pull the control knobs off.
- Remove the cover (see illustration).
- Lift the top of the appliance off.

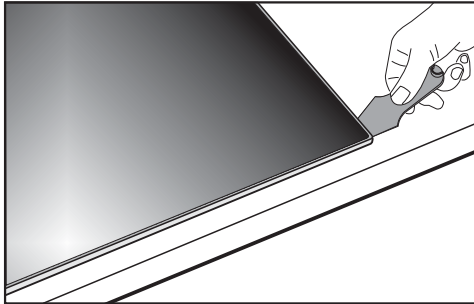

- Using a small screwdriver, unscrew small jet ① in the gas fitting.

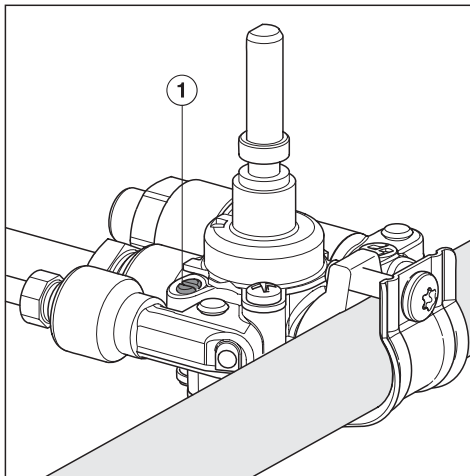

- Pull out the jet with a pair of pliers.
- Fit the correct jets securely (see jet table).
- Finally, secure the jets against inadvertent loosening with sealing wax.

Conversion to another type of gas

Function test

Check all gas fittings for leaks.

- Reassemble the appliance.
- Check the burner flame by operating the burner.

The flame must not go out on the lowest setting, or when the control is turned quickly from a high to a low setting.

On the highest setting, the flame must have a distinctive and visible core.

- Stick the label supplied with the jets above the label stating the type of gas being used.

After sales service, data plate, guarantee

In the event of any faults which you cannot remedy yourself, or if the appliance is under guarantee, please contact:

- Your Miele dealer, or
- the Miele Service Department (see back cover for address).

Please note that telephone calls may be monitored and recorded to improve our service.

When contacting Miele, please quote the model and serial number of your appliance. These are given on the data plate.

N.B. A call-out charge will be applied for service visits where the problem could have been resolved as described in these instructions.

Space in which to stick the extra data plate supplied with the appliance. Ensure that the model number is the same as the one on the front of these instructions.

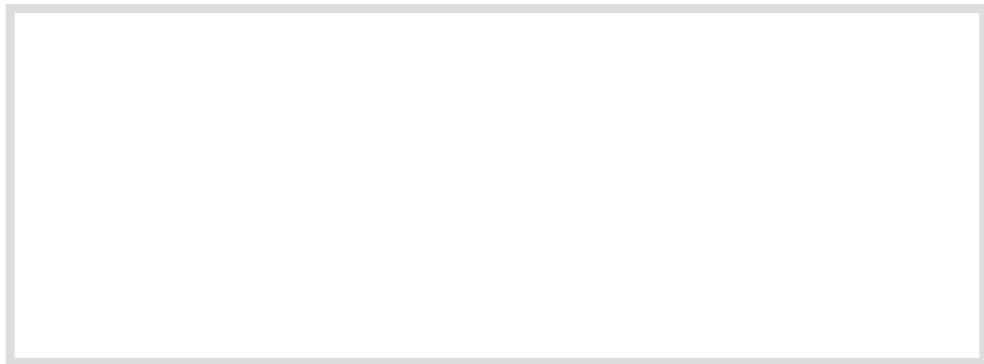

Guarantee

For information on the appliance guarantee specific to your country please contact Miele. See back cover for contact details.

In the U.K. your appliance is guaranteed for 2 years from the date of purchase. However, you must activate your cover by calling 0845 365 6640 or registering online at www.miele.co.uk.

United Kingdom

Miele Co. Ltd.
Fairacres, Marcham Road
Abingdon, Oxon, OX14 1TW
Tel: 0845 365 0555
Fax: 0845 365 0777
Customer Contact Centre Tel: 0845 365 6600
E-mail: info@miele.co.uk
Internet: www.miele.co.uk

Australia

Miele Australia Pty. Ltd.
ABN 96 005 635 398
1 Gilbert Park Drive, Knoxfield, VIC 3180
Tel: 1300 464 353, Fax: (03) 9764 7149
Internet: www.miele.com.au

China

Miele (Shanghai) Trading Ltd.
1-3 Floor, No. 82 Shi Men Yi Road
Jing' an District
200040 Shanghai, PRC
Tel: +86 21 6157 3500
Fax: +86 21 6157 3511
E-mail: miele Shanghai@cn.miele.com
Internet: www.miele.cn

Miele (Hong Kong) Limited

41/F - 4101, Manhattan Place
23 Wang Tai Road
Kowloon Bay
Hong Kong
Tel: (852) 2610 1331
Fax: (852) 2610 1013
Email: mielehk@miele.com.hk

India

Miele India Pvt. Ltd.
Ground Floor, Copia Corporate Suites
Plot No. 9, Jasola
New Delhi - 110025
Tel: 011-46 900 000, Fax: 011-46 900 001
E-mail: customercare@miele.in
Internet: www.miele.in

Manufacturer: Miele & Cie. KG
Carl-Miele-Straße 29, 33332 Gütersloh, Germany



Ireland

Miele Ireland Ltd.
2024 Bianconi Avenue
Citywest Business Campus, Dublin 24
Tel: (01) 461 07 10, Fax: (01) 461 07 97
E-Mail: info@miele.ie, Internet: www.miele.ie

New Zealand

Miele New Zealand Limited
Unit L, 10-20 Sylvia Park Road
Mt. Wellington, 1060, Auckland, NZ
Tel: 0800 264 353, Fax: 0800 463 453
Internet: www.miele.co.nz

Singapore

Miele Southeast Asia
Miele Pte. Ltd.
163 Penang Road
04 - 02/03 Winsland House II
Singapore 238463
Tel: +65 6735 1191, Fax: +65 6735 1161
E-Mail: infosea@miele.com.sg
Internet: www.miele.sg

South Africa

Miele (Pty) Ltd
63 Peter Place, Bryanston 2194
P.O. Box 69434, Bryanston 2021
Tel: (011) 875 9000
Fax: (011) 875 9035
E-mail: info@miele.co.za
Internet: www.miele.co.za

United Arab Emirates

Miele Appliances Ltd.
P.O. Box 11 47 82
Gold & Diamond Park
Sheikh Zayed Road
Building 6 / Offices Nos. 6-214 to 6-220
Dubai
Tel: +971-4-341 84 44
Fax: +971-4-341 88 52
E-Mail: info@miele.ae
Internet: www.miele.ae