

RB SXT G-5HPnD-HG

Quick Setup Guide and Warranty Information

The SXT G-5HPnD-HG comes as a complete set, and includes a built in 802.11n dual chain wireless device, and a dual polarization 16dBi high gain antenna. It has one Gigabit Ethernet connector which supports MDI-X auto detection.

First use

1. Connect an Ethernet cable to the port behind the small plastic door
2. The SXT accepts 24V Passive PoE from the supplied PoE injector
3. The default IP address from LAN is 192.168.88.1 for configuration
4. Username is **admin** and there is no password

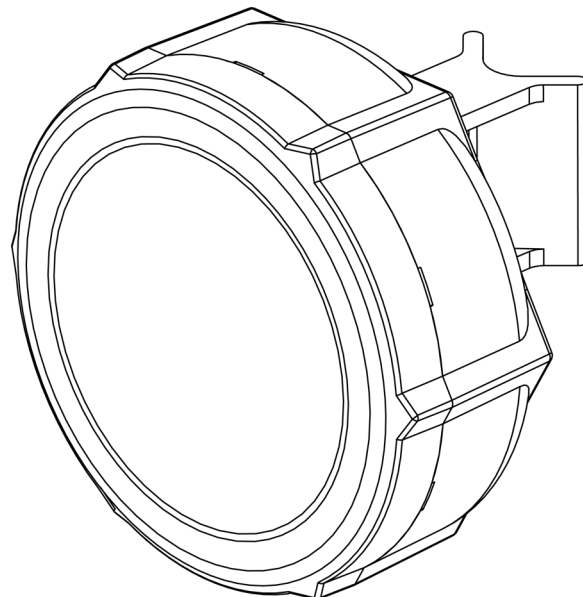

Powering

The board accepts powering from the Ethernet port (Passive PoE) 8-30V DC. Package contains a 24V adapter.

Booting process

RouterOS is the operating system of all RouterBOARD routers. Please see detailed configuration guide here: <http://wiki.mikrotik.com/wiki/Category:Manual>

This device doesn't come fitted with a Serial Port connector, so initial connection has to be done via the Ethernet cable, using the MikroTik Winbox utility. Winbox should be used to connect to the default IP address of **192.168.88.1** with the username **admin** and no password.

In case IP connection is not available, Winbox can also be used to connect to the MAC address of the device. More information here: http://wiki.mikrotik.com/wiki/First_time_startup

In case you wish to boot the device from network, for example to use MikroTik Netinstall, hold the RESET button of the device when starting it until the LED LD600 light turns off (behind the small door), and SXT will start to look for Netinstall servers.

Mounting

With the clip pointed forward, slide the mounting bracket into the rail on the bottom of the case, until the clip clicks into place. The SXT comes bundled with a hose clamp - guide the clamp through the opening in the bracket and around the pole where it will be mounted. Tighten the hose clamp screw when alignment is complete. Two screw holes are provided as additional security against accidental bracket movement.

The SXT device has a sliding door, behind which the Ethernet port and the reset jumpers are located. This door can be also secured shut with a screw in the provided screw hole.

Buttons and Jumpers

- RouterOS reset jumper hole (access through the plastic door) – resets RouterOS software to defaults. Must short circuit the metallic sides of the hole (with a screwdriver, for example) and boot the device. Hold screwdriver in place until RouterOS configuration is cleared.
- RouterBOOT reset button (access through the plastic door) has two functions:
 - ✓ Hold this button during boot time until LED light starts flashing, release the button to **reset RouterOS configuration** (same result as with reset hole)
 - ✓ Hold this button during boot time longer, until LED turns off, and then release it to make the device **look for Netinstall servers**.

Operating System Support

Currently tested operating system is MikroTik RouterOS (starting from version v5).

Copyright and Warranty Information

Copyright and Trademarks. Copyright MikroTik SIA. This manual contains information protected by copyright law. No part of it may be reproduced or transmitted in any form without prior written permission from the copyright holder. RouterBOARD, RouterOS, RouterBOOT and MikroTik are trademarks of MikroTik SIA. All trademarks and registered trademarks appearing in this manual are the property of their respective holders.

Hardware. MikroTik SIA warrants all RouterBOARD series equipment for the term of fifteen (15) months from the shipping date to be free of defects in materials and workmanship under normal use and service, except in case of damage caused by mechanical, electrical or other accidental or intended damages caused by improper use or due to wind, rain, fire or other acts of nature.

If you have purchased your product from a MikroTik Reseller, please contact the Reseller company regarding all warranty and repair issues, the following instructions apply **ONLY** if you purchased your equipment directly from MikroTik Latvia

To return failed unit or units to MikroTik you must perform the following RMA (Return Material Authorization) procedure. Follow the instructions below to save time, efforts, avoid costs, and improve the speed of the RMA process. Take into account that all goods have one year warranty.

Instructions are located on our webpage here: <http://rma.mikrotik.com>

Manual. This manual is provided “as is” without a warranty of any kind, expressed or implied, including, but not limited to, the implied warranty of merchantability and fitness for a particular purpose. The manufacturer has made every effort to ensure the accuracy of the contents of this manual; however, it is possible that it may contain technical inaccuracies, typographical or other errors. No liability is assumed for any inaccuracy found in this publication, nor for direct or indirect, incidental, consequential or other damages that may result from such an inaccuracy, including, but not limited to, loss of data or profits. Please report any inaccuracies found to support@mikrotik.com

Federal Communication Commission Interference Statement (FCC ID: TV7SXTG-5HPND)

This equipment has been tested and found to comply with the limits for a Class B digital device, pursuant to Part 15 of the FCC Rules. These limits are designed to provide reasonable protection against harmful interference in a residential installation.



This equipment generates, uses and can radiate radio frequency energy and, if not installed and used in accordance with the instructions, may cause harmful interference to radio communications. However, there is no guarantee that interference will not occur in a particular installation. If this equipment does cause harmful interference to radio or television reception, which can be determined by turning the equipment off and on, the user is encouraged to try to correct the interference by one of the following measures:

- Reorient or relocate the receiving antenna.
- Increase the separation between the equipment and receiver.
- Connect the equipment into an outlet on a circuit different from that to which the receiver is connected.
- Consult the dealer or an experienced radio/TV technician for help.

FCC Caution: Any changes or modifications not expressly approved by the party responsible for compliance could void the user's authority to operate this equipment.

This device complies with Part 15 of the FCC Rules. Operation is subject to the following two conditions: (1) This device may not cause harmful interference, and (2) this device must accept any interference received, including interference that may cause undesired operation.

This device and its antenna must not be co-located or operation in conjunction with any other antenna or transmitter.

IMPORTANT: Exposure to Radio Frequency Radiation.

27 cm minimum distance has to be maintained between the antenna and the occupational user and 60 cm to general public. Under such configuration, the FCC radiation exposure limits set forth for an population/uncontrolled environment can be satisfied.

Antenna Installation. WARNING: It is installer's responsibility to ensure that when using the authorized antennas in the United States (or where FCC rules apply); only those antennas certified with the product are used. The use of any antenna other than those certified with the product is expressly forbidden in accordance to FCC rules CFR47 part 15.204. The installer should configure the output power level of antennas, according to country regulations and per antenna type. Professional installation is required of equipment with connectors to ensure compliance with health and safety issues.