

NOTEBOOK COMPUTER

RT10

User's Guide
(Preliminary Version)

Notice

The company reserves the right to revise this publication or to change its contents without any notice. Information contained herein is for reference only and does not constitute a commitment on the part of the manufacturer or any subsequent vendor. They assume no responsibility or liability for any errors or inaccuracies that may appear in this publication nor are they in anyway responsible for any loss or damage resulting from the use (or misuse) of this publication.

Any of the software described in this manual is sold or licensed "as is". Should the programs prove defective following purchase, the buyer (and not the manufacturer, its distributor, or its dealer) assumes the entire cost of all necessary servicing, repair and any incidental or consequential damages resulting from any software defects.

Brand and product names mentioned in this publication may or may not be copyrights and/or registered trademarks of their respective companies. They are mentioned for identification purposes only and are not intended as an endorsement of that product or its manufacturer.

Copyright© 2015, MilDef Crete Inc. All rights reserved.

Trademarks

All other brand and product names are trademarks or registered trademarks of their respective companies.

Revision History:

Revision	Date	Changes	Author
----------	------	---------	--------

FCC (Federal Communications Commission) Statement

This equipment has been tested and found to comply with the limits for a Class B digital device pursuant part 15 of the FCC Rules. These limits are designed to provide reasonable protection against harmful interference in a residential installation.

This equipment generates, uses, and radiates radio frequency energy. If not being installed and used in accordance with the instructions, it may cause harmful interference to radio communications. However, there is no guarantee that interference will not occur in a particular installation. If this equipment does cause harmful interference to radio or television reception, which can be determined by turning the equipment off and on, the user is encouraged to try to correct the interference by one or more of the following measures:

- Re-orient or relocate the receiving antenna.
- Increase the separation between the equipment and receiver.
- Connect the equipment into an outlet on a circuit different from that to which the receiver is connected.
- Consult the dealer or an experienced radio/TV technician for help.

This device complies with Part 15 of the FCC Rules. Operation is subject to the following two conditions:

- This device may not cause harmful interference.
- This device must accept any interference received, including interference that may cause undesired operation.
-
- This radio transmitter FCC ID: IR5RT10 has been approved by FCC to operate with the antenna types listed below with the maximum permissible gain and required antenna impedance for each antenna type indicated. Antenna types not included in this list, having a gain greater than the maximum gain indicated for that type, are strictly prohibited for use with this device.
- Antenna Information : antenna type: PIFA Antenna gain: -0.36dBi for 2.4GHz / 0.85dBi for 5GHz
- 5150 ~5250MHz is for indoor used only.



FCC Caution:

To assure continued compliance, any changes or modifications not expressly approved by the party responsible for compliance could void the user's authority to operate this equipment. (Example - use only shielded interface cables when connecting to computer or peripheral devices).

Radiation Exposure Statement

This equipment complies with FCC radiation exposure limits set forth for an uncontrolled environment. This equipment should be installed and operated with minimum distance 20cm between the radiator & your body.

Regulatory Information/ Disclaimers

Installation and use of this computer must be in strict accordance with the instructions included in the user documentation provided with the product. Any changes or modifications (including the antennas) made to this device that are not expressly approved by the manufacturer may void the user's authority to operate the equipment.

The manufacturer is not responsible for any radio or television interference caused by unauthorized modification of this device, or the substitution of the connecting cables and equipment other than manufacturer specified. It is the responsibility of the user to correct any interference caused by such unauthorized modification, substitution or attachment. Manufacturer and its authorized resellers or distributors will assume no liability for any damage or violation of government regulations arising from failing to comply with these guidelines.

CE

Products with the CE Marking comply with both the EMC Directive (2004/108/EC) and the Low Voltage Directive (2006/95/EC) issued by the Commission of the European Community.

Compliance with these directives implies conformity to the following European Norms:

EN55022 CISPR 22 Radio Frequency Interference

EN55024 EN61000-4-2, EN61000-4-3, EN61000-4-4, EN61000-4-5, EN61000-4-6, EN61000-4-8, EN61000-4-11, EN61000-3-2, EN61000-3-3, Generic Immunity Standard

LVD EN 60950-1: 2006+ A11: 2009+ A1: 2010+ A12: 2011

IEC 60950-1: 2005+AM1:2009

R&TTE (CE) Manual Regulatory Requirement

WLAN - IEEE 802.11a/b/g/n

GPS

802.11a/b/g/n Restrictions:

European standards dictate maximum radiated transmit power of 100mW EIRP and frequency range 2.400-2.4835 GHz./ 5.150 ~5.250GHz

CE Declaration of Conformity



It is confirmed to comply with the requirements set out in the Council Directive on the approximation of the laws of the member states relating to Electromagnetic Compatibility (2004/108/EC), Low-voltage Directive (2006/95/EC), the Amendment Directive (93/68/EEC), and the procedures given in European Council Directive (99/5/EC and 2004/108/EC).

The equipment was passed, and the equipment test was performed according to the following European standards:

EN 300 328 V1.7.1 (2006)

EN 301 893 V1.6.1 (2011)

EN 301 489-1 V1.9.2 (2011)

EN 301 489-3 V1.4.1 (2002)

EN 301 489-17 V2.2.1 (2012)

EN62311 2008

EN300440-1 V1.6.1 2010

EN300440-2 V1.4.1 2010

UL, TÜV

AC Adapter (TÜV includes **LVD EN60950**)

Power Conservation

This computer consumes much less power than conventional computers. However, power consumption may be reduced by configuring the Power Management Setup properly.

It is recommended the power saving functions to be enabled even when not running on battery power.

Power Management will not degrade performance while saving power.

Power Safety

There are specific power requirements for this computer:

- Only use an approved power adapter for this computer.
- There is a 3-prong grounded plug of the power adapter. The third prong is an important for safety. Do not neglect the importance for it. If you are not able to access a compatible outlet, installing one by a qualified electrician is necessary.
- When unplugging the power cord, please be sure to disconnect it from the plug head but from its wire.
- Make sure the socket and any other extension cord you use can support the total current load of all the connected devices.
- Before cleaning the computer, make sure it is disconnected from any external power supplies.



Warning:

Before any upgrade procedures, make sure the power is turned off, and all the cables are disconnected (including telephone lines). Also, it is advisable to re-move your battery in prevent from turning the computer on accidentally.

Battery Precautions

- Only use the batteries designed for this computer. The wrong battery may cause explosion, leakage or damage to the computer.
- Do not remove the battery from the computer while it is powered on.
- Do not continuously use a battery that has been dropped, or that appears damaged (e.g. bent or twisted) in any way. Even if the computer is able to continuously work with a damaged battery, the circuit damage may occur and possibly cause fire.
- Always use the notebook's system or charger to recharge the battery. Incorrect recharging may make the battery explode.
- Do not try to repair a battery pack by yourself. Refer to any battery pack repair or replacement, please contact with to your service representative or qualified service personnel.
- Please dispose of a damaged battery promptly and carefully. Explosion or leakage may occur, if the battery is exposed to fire, improperly handled or discarded.



Battery Disposal & Caution:

The product that you have purchased contains a rechargeable battery. The battery is recyclable. At the end of its service life, under various state and local laws, it may be illegal to dispose of this battery into the municipal waste stream. Check with your local solid waste officials for details in your area for recycling options or proper disposal. Danger of explosion may possibly occur, if the battery is incorrectly replaced. Replace only with the same or the equivalent battery recommended by the manufacturer. Discard the used battery according to the manufacturer's instructions.

Environmental Information, Material Safety & Recycling

All materials used in the manufacturing of this equipment are recyclable or environmentally friendly.

Please recycle the packing materials by the local regulations at the end of the product's service life.

Notice:

- The equipment may still contain tiny amount of hazardous substances for health and environment, though those are below control level.
- To avoid spreading such substances into the eco system, and to minimize the pressure on the natural, you are encouraged to use the appropriate take-back for reusing or recycling most of the materials in a safe way after the service life.
- The crossed bin symbol indicates proper disposal is required.
- For more information on collection, reuse and recycling, please consult the local or regional waste administration for more information.
- You can also contact with the dealer for more information on the environmental details of the equipment.
- The symbol of the crossed-out wheeled bin indicates that the product (electrical and electronic equipment) should not be placed in municipal waste. Please check local regulations for disposal of electronic products.



TABLE OF CONTENTS

CHAPTER ONE - GETTING STARTED	1
UNPACKING	1
QUICK OPERATION	2
APPEARANCE OVERVIEW	3
CHAPTER TWO - OPERATING INFORMATION	8
WORKPLACE	8
RUGGEDNESS	8
OPERATING SYSTEM	9
WORK WITH POWER BUTTON	9
BOOT UP AND POST	10
SHUT DOWN	10
SLEEP/HIBERNATE	10
INTEL® RAPID START TECHNOLOGY	11
KEYBOARD	12
KEYBOARD BACKLIGHT (OPTION)	13
HARD DISK DRIVE (HDD) / OPTIONAL SOLID STATE DRIVE (SSD)	14
OPTICAL DISK DEVICE (ODD)	14
EXPRESS CARDS	15
PCMCIA CARD	16
RTC	17
REPLACING MODULES	18
WIRELESS DEVICES (OPTION)	19
CHAPTER THREE - MANAGING POWER	22
AC ADAPTER	22
BATTERY	23
POWER CONSERVATION	25
SUPPORTING ACPI	25
CHAPTER FOUR - BIOS SETUP	26
MAIN MENU	26
ADVANCED MENU	27
TRUSTED COMPUTING SUB-MENU	29
SATA CONFIGURATION SUB-MENU	30
SATA CONFIGURATION SUB-MENU SELECTIONS	30
INTEL (R) RAPID START TECHNOLOGY SUB-MENU	31
USB CONFIGURATION SUB-MENU	32
USB CONFIGURATION SUB-MENU SELECTIONS	32
IT8783F SUPER IO CONFIGURATION SUB-MENU	33

IT8783F H/W MONITOR SUB-MENU.....	34
RF DEVICE CONTROL CONFIGURATION SUB-MENU.....	35
EC THERMAL CONTROL SUB-MENU	36
USB CHARGE CONTROL SUB-MENU	36
CHIPSET MENU	37
CHIPSET MENU SELECTIONS.....	37
SYSTEM AGENT CONFIGURATION SUB-MENU	37
GRAPHICS CONFIGURATION SUB-MENU	38
LCD CONTROL SUB-MENU	38
PANEL TYPE SELECTIONS	38
PCH-IO CONFIGURATION SUB-MENU	39
BOOT MENU	40
BOOT MENU SELECTIONS	40
SECURITY MENU	41
SAVE & EXIT MENU	42

CHAPTER FIVE - DRIVERS AND APPLICATIONS 43

CHIPSET	43
VGA	44
AUDIO	44
INTEL ME	45
INTEL RAPID STORAGE TECHNOLOGY	45
WIRELESS POWER MANAGER.....	46
TOUCH SCREEN	46
USB3.0	47
RICOH SD CONTROLLER.....	48
TURBO BOOST MONITOR	48
GIGABIT LAN.....	49
WiFi (OPTION).....	50
BLUETOOTH (OPTION)	51
GPS (OPTION)	52
TPM (OPTION)	53

CHAPTER SIX - SPECIFICATIONS 54

PLATFORM.....	54
CPU	54
PCH	54
MEMORY	54
DISPLAY	54
KEYBOARD	54
TOUCHPAD	55
HARD DISK DRIVE (HDD) / OPTIONAL SOLID STATE DRIVE (SSD)	55
OPTICAL DISK DRIVE (ODD).....	55
I/O PORTS.....	55

AC ADAPTER	56
BATTERY	56
SYSTEM UNIT DIMENSIONS AND WEIGHT	56
MATERIALS AND RECYCLING	57
ENVIRONMENTAL	57
CHAPTER SEVEN - OPTIONAL DEVICES	58
COMMUNICATION.....	58
MEMORY CARD.....	58
TOUCH SCREEN	58
SURGE PROTECTOR/BVA MODULE	58
VEHICLE ADAPTER	59
2 ND BATTERY	59
2 ND HDD	60
ODD.....	60
KB DUST COVER	60
DUAL BATTERY CHARGER RT202D.....	60
TRUST PLATFORM MODULE (TPM).....	60
CHAPTER EIGHT - MAINTENANCE AND SERVICE	61
CLEANING.....	61
TROUBLESHOOTING.....	61
RMA SERVICE	62

Chapter One - Getting Started

Unpacking

The following components are along with your computer. If there is any missing or damaged, please notify the dealer immediately.

- Computer Unit
- Removable HDD (Hard Disk Drive)
- Removable ODD (Optical Disk Drive)
- AC Adapter
- AC Power Cord
- Utility DVD
- Quick Guide
- Carrying Bag

Quick Operation

- Loosen the battery screw, remove the battery insulation sheet, and mount the battery.
- Connect the AC adapter with the computer and start charging the battery for at least 10 minutes.
- Turn ON the computer by pressing the power switch.

Notice:

- When ambient temperature is under +5°C (This is the default setting for this computer.), the system may not boot up immediately. System will beep with LED heater light flashing to remind the user while heater working. Also, the frequency of the LED will become faster to remind the user while the temperature is approaching to be suitable. After 5~15 minutes, the system will boot up automatically.
- Under an emergency situation, it is able to skip heating for booting up the system immediately by pressing the power switch for >9 seconds. The speaker will also beep with a special sound. (It is not guaranteed all devices on the computer are possible to work properly.)
- Press the power switch again during the heating process will shut down the computer.
- Driver or application installation may be necessary for further operation.
- The following procedures will help to Turn OFF the computer:
 1. Press power switch to “**Shut Down**”, “**Sleep**”* or “**Hibernate**”* depending on operating system (OS) and power management settings.
 2. Press power switch for 4 seconds for a “Hard” power off. But, note that the system will shut down immediately without saving any data or parameters.
 3. Click **Start** → **Shut Down** in Windows to Turn OFF.

Note:







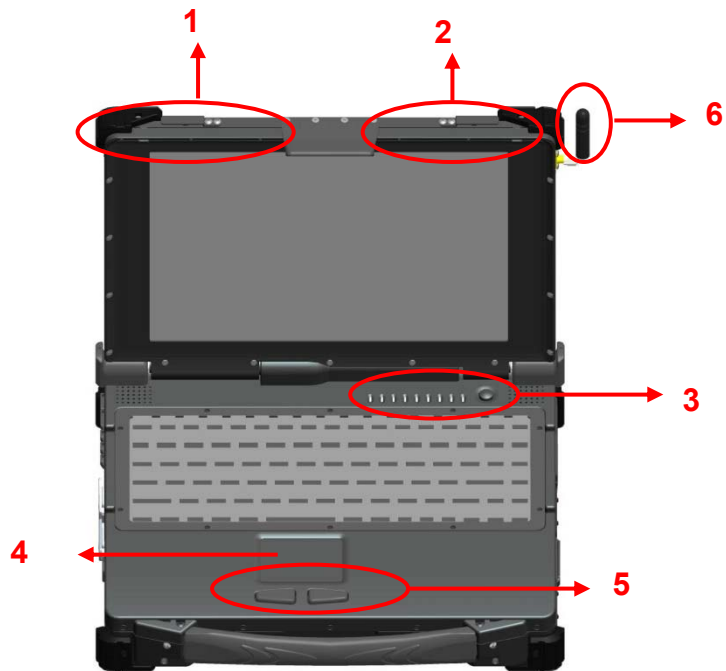



- *Some operating systems may not support the above-mentioned functions.*

Appearance Overview

LCD Panel Open



- 1. Embedded Antennas (Option): WLAN
- 2. Embedded Antennas (Option): WLAN/BT
- 3. LED Indicators and Power Switch:

 Heater	 HDD in Use
 BT/WLAN/GPS	 Secondary Battery Charging
 Keyboard Number Lock	 Primary Battery Charging
 Keyboard Caps Lock	 Power Indicator
 Keyboard Scroll Lock	 Power Switch

- 4. Touchpad
- 5. Touchpad Right and Left Button

Right View

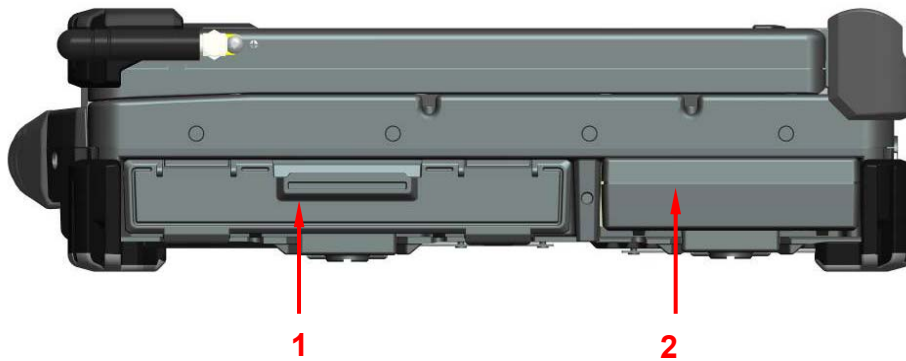

1. Flex Bay:
 - a. Standard: SATA ODD (Optical Disk Drive)
 - b. Optional: 2nd HDD or 2nd Battery
2. SATA HDD (Hard Disk Drive) / Optional SSD (Solid State Drive)

Left View

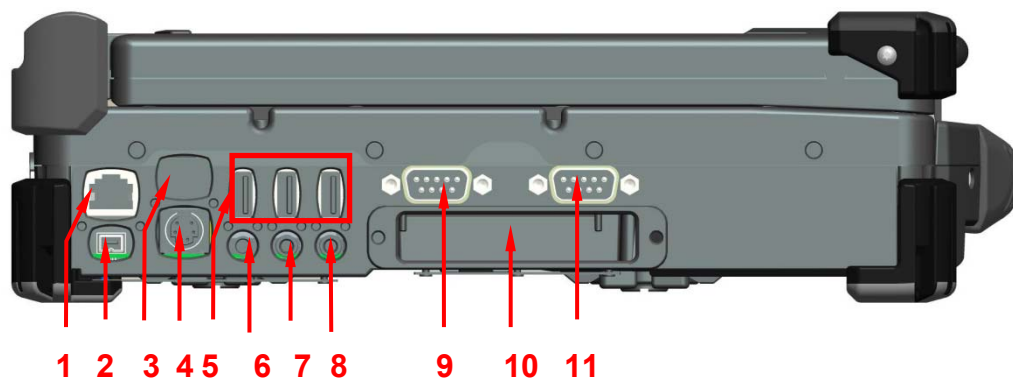

1. 2nd GLAN RJ45
2. IEEE1394 Port (Fire Wire)
3. GLAN RJ45
4. PS/2 Port (Keyboard + Mouse)
5. USB Port 2.0 x 3
6. Headphone Jack
7. Line-in Jack
8. Microphone Jack
9. Serial Port DB9
10. PCMCIA (Top) / Express Card Slot (Bottom)
11. Serial Port DB9 (COM3/4)

Note:

- *The rightmost USB port support*

Rear View

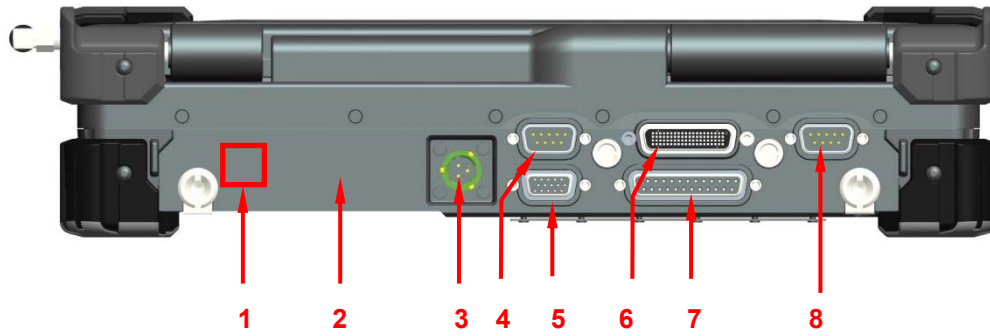

1. Optional GPS SMA Antenna
2. Optional Military Connector Port
3. DC Power Jack
4. Serial Port DB9 (COM1)
5. VGA Port
6. Docking Port
7. Printer Port
8. Serial Port DB9 (COM2)

Bottom View

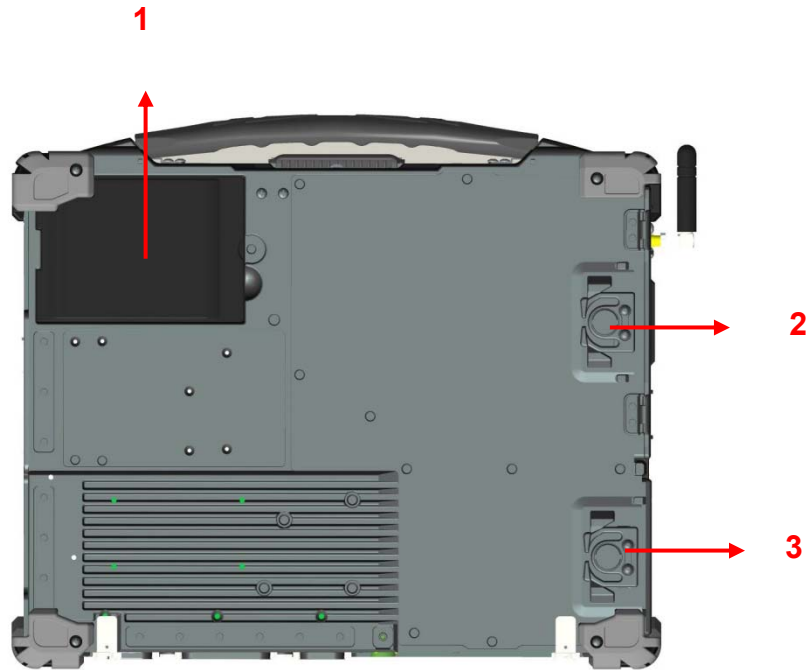

1. Primary Battery
2. ODD Latch
3. HDD Latch

Chapter Two - Operating Information

Workplace

A clean and moisture-free environment is preferred. Make room for air circulation. Remember to avoid areas from:

- Sudden or extreme changes in temperature.
- Extreme heat.
- Strong electromagnetic fields (near television set, motor rotation area, etc.).
- Dust or high humidity.

If it is necessary to work in a hostile environment, please regularly maintain your notebook computer by cleaning dust, water, and etc. to keep it in an optimal condition.

Ruggedness

This notebook computer is designed with rugged features such as vibration, shock, dust, and rain/ water protection. However, it is still necessary to provide appropriate protection while operating in harsh environments.

The notebook computer is also designed to withstand rainfall from top with mild wind blowing only. Please keep the keyboard facing up, i.e. normal operating direction, to maintain water resistance. NEVER immerse the unit in water, or spray water at an upside-down system. Doing so may cause permanent damage.

The D-sub connector caps on the rear of the computer are for dust and shock protection. The connectors are sealed internally. Other I/O ports and devices on the left or right must have caps tightly closed or cable inlets sealed while being exposed to water or dust.

There are optional gaskets for DB-9 and DB-25 connectors. You may install them to improve rain/ dust/ moisture resistance on your commercial type cable. Insert the packing into the male connector (with pins) and fasten the screws.

All connectors will be corroded if being exposed to water or moisture. Corrosion is accelerated if the power is ON. Please take proper water-resistant measures for cable connections. The DC jack and cables are sealed and may be operated with water splashing while attached. All port covers should be in place when no cable is attached.

Operating System

Your computer is designed to operate with Microsoft Windows 7/8 32/64-bit Operating System. Please connect your computer with an external USB-interface drive, such as a USB thumb drive, and start the OS installation.

Work with Power Button

Since the notebook computer is equipped with a heater kit to enable the unit to work under low temperature, the heater will first heat HDD up to the temperature set by user, and the system will boot after then. Also, the heater will keep monitoring HDD temperature. Once the temperature becomes lower, the heater will heat up again to maintain the temperature set by user.

The function will be different from the way you use with the power button:

1. Press 12 seconds and release:
USB port is enabled and you can set a new value in Heater AP.
2. Press 9~11 seconds:
The system will be forced to boot up.
3. Press 5~8 seconds:
Enable/Disable the sound of Heater.
4. Press 4 seconds under OS:
Shut down the system.
5. Click the Power button.
 - a. Power on the system in S5 status.
 - b. Click while heating up, the system will be forced to shutdown
 - c. Entering S3/S4 under OS.

Boot Up and POST

Boot up

The computer turns ON and loads the operating system (such as Windows) into the system memory. This start-up procedure is called “boot up”.

The ROM BIOS Power on Self-Test (POST)

Each time the computer powers on, it automatically performs a self-test of its memory and hardware devices.

Note:

- *USB 3.0 controller is not native on RT10, and does not support USB boot up. If you need USB boot up function, please use USB 2.0 port.*

Shut down

Before shutting down, please always remember to save the unfinished works and close the application for preventing from any possible data loss or HDD damage.

“Shut down” will totally turn OFF the power of your notebook computer. If you want to start your notebook computer again, you need to press the power switch.

Sleep/Hibernate

Sleep

Under “Sleep” mode, the system will temporarily save your work into RAM. You are able to do enter “Sleep” mode by directly clicking from your OS. Or, you can do the “Sleep” Mode settings in your OS. If you want to start your notebook computer again, all you need to press any key.

Hibernate

Under “Hibernate” mode, the system will save your work into HDD. You are able to do enter “Hibernate” mode by directly clicking from your OS. Or, you can do the “Hibernate” Mode in your OS. If you want to start your notebook computer again, you need to press the power switch.

Intel® Rapid Start Technology

Your computer can operate Intel® Rapid Start Technology when SSD is installed. This technology enables your system resume time not only to be as fast as wake-up time from S3 (Sleep) mode, but also to be more energy saving.

Before using Intel Rapid Storage Technology, please check the following system requirements:

System Requirement:

- Intel QM67 Express Chipset-based desktop board
- Intel Sandy Bridge i7-2610UE
- Solid State Drive (SSD)
- Operating system: Microsoft Windows 7/8

Note:

- *Intel® Rapid Storage Technology Driver should be installed and can be found in Utility DVD.*
- *Please use “Intel® Rapid Start Technology User Guide” to setup the function. You can find the User Guide from Intel official website.*
- *Please remember to enable Rapid Start Technology from BIOS Advanced Menu.*
- *To cancel the Rapid Start Technology, please disable the function from BIOS Advanced Menu.*

Keyboard

The keyboard is functionally equivalent to a full size desktop keyboard. A sample layout is shown below.



Function Key Combinations

Key	Description
[Fn] + [F3]	Decrease LCD brightness
[Fn] + [F4]	Increase LCD brightness
[Fn] + [F5]	Keyboard Backlight (Option)
[Fn] + [F6]	Volume down
[Fn] + [F7]	Volume up
[Fn] + [F8]	Sleep Mode

The Numeric Keypad

The numeric keypad functions are the same as an electronic calculator. It is embedded in the main keyboard, with the numeric figures printed on the upper right of their respective keys. There are keys for the digits 0~9, the decimal point (.), addition (+), subtraction (-), multiplication (*), and division (/) in the keypad.

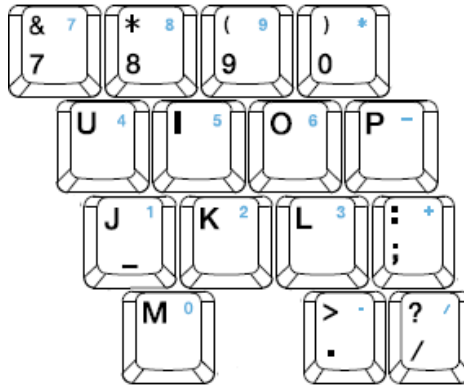

To activate the keypad, press the **[Fn] + Num Lock** key. There are 15 keys switching from alphabetic to numeric. Press **[Fn] + Num Lock** again to return.

Keyboard Backlight (Option)

Press **[Fn] + [F5]** key for approximately 1 second to turn the keyboard backlight ON or OFF.

Hard Disk Drive (HDD) / Optional Solid State Drive (SSD)

Your Notebook computer is equipped with 2.5" SATA II Hard Disk Drive (HDD), or optional Solid State Drive (SSD) for data storage. HDD/SSD is user removable, providing convenience and security. It can **ONLY** be removed while power is **OFF**.

Note:

NEVER drop your HDD/SSD or expose them to high temperature, high humidity, or any hazardous environment. NEVER try to disassemble the module. Static discharge may destroy your device and data. Always pick up the modules by touching the case only.

Optical Disk Device (ODD)

There is a 5.25" type/ 12.7mm height **SATAII interface** ODD. The actual device will depend on the model you purchased. The ODD may be used as a boot device if properly set in the BIOS.

The ODD accepts a variety of standard 12cm CDs, DVD-ROM (Single Layer, Dual Layer), DVD-Video, DVD-R*10 (1.4 GB, 2.8 GB, 4.7GB), DVD-RW (Ver.1.1/1.2 1.4 GB, 2.8 GB, 4.7 GB, 9.4 GB), DVD-R DL (8.5 GB), DVD-RAM (1.4 GB, 2.8 GB, 4.7 GB, 9.4 GB), +R (4.7 GB), +R DL (8.5 GB), +RW (4.7 GB), CD-Audio, CD-ROM (XA compatible), CD-R, Photo CD (multiple session compatible), Video CD, CD EXTRA, CD-RW, CD-TEXT and etc.

Caution: Do not use the IDE-interface ODD; it may cause the computer malfunction.

The following procedure assumes that all the necessary ODD utilities were installed on the computer. For ODD utility installation, please refer to "**Utilities and Drivers**". ODD also can be removed and swapped with the 2nd battery or 2nd SATA HDD.

Put disk into the ODD

While the power is ON, push the ejecting button of ODD. The tray will release. Then gently pull the tray out. Put the disk with its label facing up on the holder and push the tray back into the cabinet. Any dirt on the data side of the disk may cause to the erroneous read. Please avoid touching the data side.

Read from the ODD

The ODD may be designated as drive D: or higher depending on your configuration. You may access to it in DOS or Windows. Please avoid shock or vibration when the optical device is active.

Express Cards

The computer supports 54 mm or 34 mm wide ExpressCard. You can install an ExpressCard while the computer is running. The computer automatically detects the card.

To install an ExpressCard:

- Hold the card with the top side of the card.
- Slide the card into the slot until the card is completely seated in its connector.

To remove an ExpressCard:

Press the card and remove the card gently.

The following illustration shows the insertion of ExpressCard 54mm:

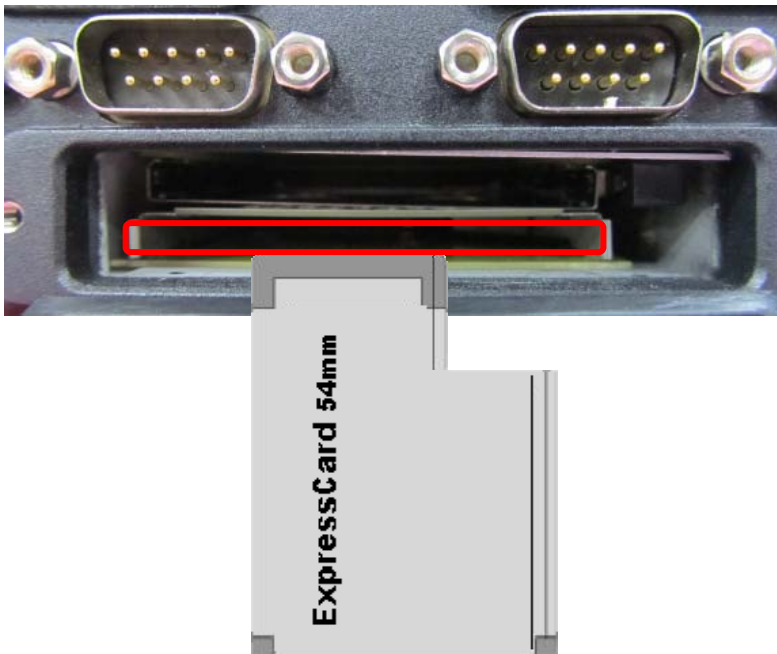

PCMCIA Card

The computer supports 1x type-II PCMCIA card. To remove the card, push the eject button. The eject button can hide into the compartment by pushing it inward gently.

The following illustration shows the location of PCMCIA slot and the eject button.

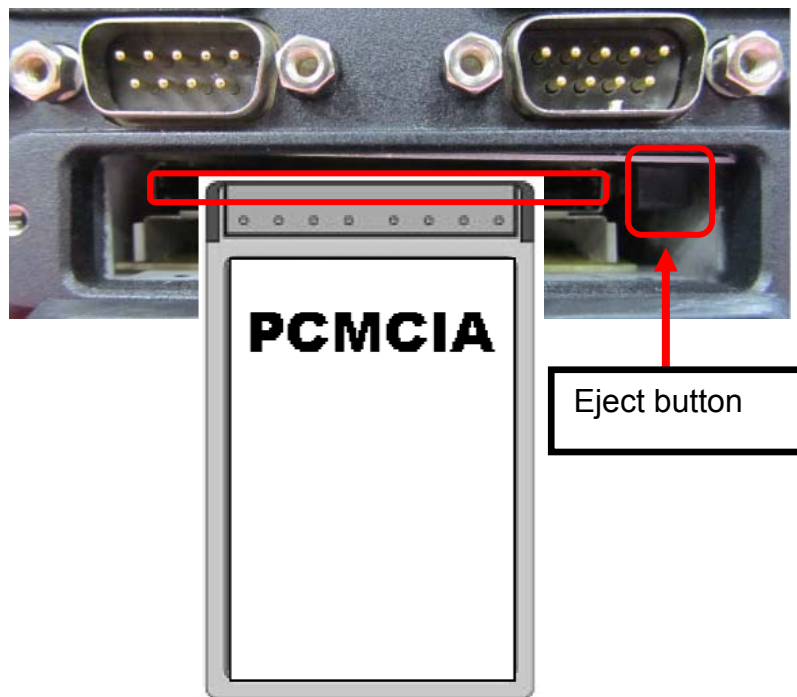

RTC

Battery backed up RTC (Real Time Clock/Calendar) is built in an on-board CMOS (Complementary Metal Oxide Semiconductor) chip. The RTC keeps track of the time and date while the computer is off. The CMOS chip also stores system setup information. RTC battery is also recharged when AC adapter is attached. Recharge the computer approximately once per month to ensure RTC operation.

Replacing Modules

To remove the modules:

1. Turn OFF the computer or hibernate.
2. Disconnect all cables from the computer.
3. Use a coin to turn and loose the screws on the modules.
4. Remove the battery from the compartment.
5. Push the latch knob to release the ODD or HDD module and push them outward.
6. Remove the module from the computer.

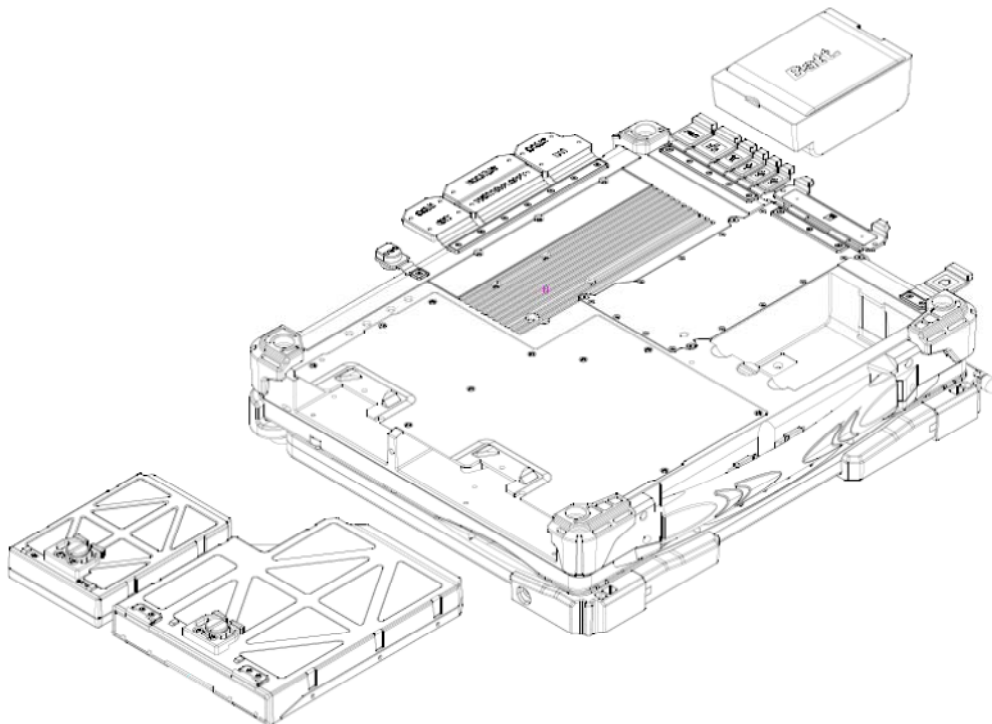

To re-install the modules:

Gently push the module into the slot. Fasten the screw to fix the module.



Caution:

You must turn the power OFF before replacing the ODD and HDD modules.

Wireless Devices (Option)

Before using wireless devices, please use the Device Power Manager to turn on the wireless devices you plan to use.

The following instructions are only for the models with optional Wireless Devices (Wireless LAN/ Bluetooth/ GPS) and use Windows 7 OS as the example.

Wireless LAN

- 1. Driver & Application Installation:**
 - a. Install the Chipset Driver first.
 - b. Then, install the Wireless Manager.

- 2. Launch the Device Power Manager:**
 - a. Launch the Device Power Manager.
 - b. Click “Wireless LAN” for enabling the Wireless LAN function (click again for disabling the WLAN function). Once the Wireless LAN starts up, the RF LED will turn on accordingly. Please see the illustration as below (with Wireless LAN function “ON”):

Bluetooth

1. Driver & Application Installation:

- a. Install the Bluetooth driver first.
- b. Then, install the Wireless Manager.

2. Launch the Device Power Manager:

- a. Launch the Device Power Manager.
- b. Click "Bluetooth" for enabling the Bluetooth function (click again for disabling the Bluetooth function). Once the Bluetooth starts up, the RF LED will turn on accordingly. Please see the illustration as below (with Bluetooth function "ON"):

GPS

1. Driver & Application Installation:

- a. Install the GPS driver first.
- b. Then, install the Device Power Manager.

2. Launch the Device Power Manager:

- a. Launch the Device Power Manager.
- b. Click "**GPS**" for enabling the GPS function (click again for disabling the GPS function). Once the GPS starts up, the RF LED will turn on accordingly.

3. Navigation & Mapping Software Installation

Please install your 3rd party navigation and mapping software after installing your GPS driver. Refer to your navigation and mapping software manual for installation and procedures on application setup and access.

Chapter Three - Managing Power

AC Adapter

The AC adapter performs two functions:

- It powers the computer from an external AC source.
- It charges the computer battery.

The adapter automatically detects the AC line voltage (100V or 240V) and adjusts accordingly.

The following are recommended when using the AC adapter:

- Use a properly grounded AC outlet.
- Use one AC outlet exclusively for the computer. Having other appliances on the same line may cause interference.

Connecting the AC adapter:

- Plug the AC cord to the adapter.
- Plug the other end of the AC cord into the wall outlet. Make sure the green LED on the adapter turns on.
- Attach the DC plug into the power jack of the computer; and turn the lock ring clockwise to secure it.

AC Adapter Indicator:

The green LED indicates that AC power is ready.

Note:

- *To ensure system stability, please connect your computer to an external power source when operating at -20 °C ambient temperature.*

Battery

The power source will automatically switch to battery when the external power source (AC adapter or optional vehicle adapter) is disconnected.

Battery Low

When the battery is nearly exhausted, the computer gives the following “Battery Low” warnings:

- Windows battery low warning (when operating system is Windows).
- The power LED flashes.

Once the Battery Low warning occurs, please:

- Save and close the files you are currently working on.
- Plug in the AC adapter to recharge the battery.

Charging the Battery

Plug in the AC adapter (or optional vehicle adapter) to start the battery charging. If the battery is already full, the sense circuitry will stop high current charge within several minutes.

There are two LED indicators next to the power indicator for the Primary and Secondary battery respectively. Indicator turns ON when the battery is charging and turns OFF when the battery charging is completed.

To charge the Secondary battery, simply install it into the computer and attach the AC adapter. The internal charger will charge the Primary battery first. The Secondary battery will be charged once the Primary battery charges full. Optional Dual Battery Charger can charge the Primary and Secondary batteries externally.

Battery Gauge

You may check battery status from battery gauge in Windows. Click the power/battery icon to reveal the battery gauge window.



Battery Power Saving Tips

The computer comes with an intelligent power-saving feature. You may extend the battery life by:

- Setup power saving functions in Operating System Power Management options (e.g. Windows Power Options).
- Lower the intensity of the display by brightness control.
- Use standby option when computer is temporarily not in use.
- Shut down the computer when it will not be for a long-time use.

Replacing Battery

When the battery is nearly exhausted, there are two ways to keep your notebook computer working. Connecting the AC adapter and the power cord designed for this notebook computer to start charging is one method; directly replacing a charged battery designed for this notebook computer may be the other one.

Note:

- *Always remember to turn OFF the power before replacing the battery.*

Power Conservation

This computer consumes much less power than conventional computers. However, power consumption may be reduced by configuring the Power Management Setup properly.

It is recommended the power saving functions to be enabled even when not running on battery power. Power Management will not degrade performance while saving power.

Supporting ACPI

Your notebook computer supports ACPI (Advanced Configuration and Power Interface) for power management. With ACPI and an ACPI-compliant operating system such as Windows, the feature will allow you to reduce the power consumption for energy saving. By supporting ACPI, the AC adapter LED and the Power indicator LED will show in different ways. The followings are the detailed description.

Sleep:

AC adapter LED is ON (while connecting with power)

Power LED indicator is ON; Other LED indicators are OFF

Under Hibernation:

AC adapter LED is ON (while connecting with power)

Power LED indicator is OFF; Other LED indicators are OFF

Shutdown:

AC adapter LED is ON (while connecting with power)

Power LED indicator is OFF; Other LED indicators are OFF

Chapter Four - BIOS Setup

Press **[F2]** at boot up to enter BIOS setup. Use arrow keys to select options and **[+/-]** to modify them. When finished, move to “**Exit**” and press **[Enter]** then confirm save by pressing **[Y]**.

Main Menu

Aptio Setup Utility		
Main	Advanced	Chipset
Boot	Security	Save & Exit
BIOS Information BIOS Vendor Core Version Compliancy Project Version Build Date and Time EC Version		Choose the system default language
System Language [English]		→←: Select Screen ↑↓: Select Item Enter: Select -/+ : Change Opt. F1: General Help F2: Previous Values F3: Optimized Defaults F4: Save & Exit ESC: Exit
System Date [Wed 10/23/2013] System Time [16:19:20]		
Access Level Administrator		

Note:

- *The contents may vary depending on computer configurations.*
- *Incorrect settings may cause system malfunction. To correct it, restore the Optimized Defaults with F3.*

Main Menu Selections

You can make the following selections on the Main Menu. Use the sub-menus for other selections.

Feature	Options	Description
System Date	MM/DD/YYYY	Set the system date Month, Day, Year.
System Time	HH:MM:SS	Set the system time Hour, Minute, Second.

Advanced Menu

Aptio Setup Utility	
Main	Advanced
<ul style="list-style-type: none"> ▶ Trusted Computing ▶ SATA Configuration ▶ Intel (R) Rapid Start Technology ▶ PCH-FW Configuration ▶ USB Configuration ▶ IT8783F Super IO Configuration ▶ IT8783F H/W Monitor ▶ RF Device Control ▶ EC Thermal Control ▶ USB CHARGE Control 	<p>Trusted Computing Setting</p> <hr/> <p>→←: Select Screen ↑↓: Select Item Enter: Select -/+ : Change Opt. F1: General Help F2: Previous Values F3: Optimized Defaults F4: Save & Exit ESC: Exit</p>

Advanced Menu Selections

You can make the following selections on the Advanced Menu.

Feature	Options	Description
Trusted Computing	Disabled Enabled	TPM Support
SATA Configuration	SATA Mode Selection Serial ATA Port 0 Software Preserve	SATA Mode Selection: IDE, AHCI, RAID
Intel (R) Rapid Start Technology	Disabled Enabled	Enable or disable Intel (R) Rapid Start Technology.
PCH-FW Configuration	N/A	Configure Management Engine Technology Parameter
USB Configuration	Disabled Enabled	Legacy USB Support USB3.0 Support XHCI Hand-off EHCI Hand-off
IT8783F Super IO Configuration	Serial Port Change Settings COM 1 Mode Setting	Set Parameters of Serial Port 0 (COMA)
IT8783F H/W Monitor	N/A	Monitor hardware status
RF Device Control	Disabled Enabled	GPS, BLUETOOTH, WLAN
EC Thermal Control	Thermal cooling trip point	EC Thermal Control Setting
USB CHARGE Control	Disabled Enabled	USB CHARGE Setting

Trusted Computing Sub-Menu

Advanced		Aptio Setup Utility
<p>Configuration TPM SUPPORT</p> <p>Current Status Information SUPPORT TURNED OFF</p>	<p>[Disable]</p>	<p>Enables or Disables BIOS support for security device. O.S. will not show Security Device. TCG EFI protocol and INT1A interface will not be available.</p> <hr/> <p>→←: Select Screen ↑↓: Select Item Enter: Select -/+ : Change Opt. F1: General Help F2: Previous Values F3: Optimized Defaults F4: Save & Exit ESC: Exit</p>

SATA Configuration Sub-Menu

Advanced		Aptio Setup Utility
SATA Mode Selection	[AHCI]	Determine how SATA controller(s) operate.
Serial ATA Port 0 Software Preserve	Empty Unknown	→←: Select Screen ↑↓: Select Item Enter: Select -/+ : Change Opt. F1: General Help F2: Previous Values F3: Optimized Defaults F4: Save & Exit ESC: Exit
Serial ATA Port 1 Software Preserve	Empty Unknown	
Serial ATA Port 2 Software Preserve	Empty Unknown	
Serial ATA Port 3 Software Preserve	Empty Unknown	
Serial ATA Port 4 Software Preserve	TOSHIBA MK5076 (500.1) SUPPORTED	
Serial ATA Port 5 Software Preserve	Empty Unknown	

SATA Configuration Sub-Menu Selections

You can make the following selections on the SATA configuration sub-menu.

Feature	Options	Description
SATA Mode Selection	IDE AHCI RAID	

Intel (R) Rapid Start Technology Sub-Menu

Advanced		Aptio Setup Utility
Intel (R) Rapid Start Technology [Disabled]	Enables or disable Intel (R) Rapid Start Technology	
	→←: Select Screen ↑↓: Select Item Enter: Select -/+ : Change Opt. F1: General Help F2: Previous Values F3: Optimized Defaults F4: Save & Exit ESC: Exit	

USB Configuration Sub-Menu

Advanced Aptio Setup Utility	
<p>USB Configuration</p> <p>USB Devices: 1 point</p> <p>Legacy USB Support [Enabled] USB3.0 Support [Enabled] XHCI Hand-off [Enabled] EHCI Hand-off [Disabled]</p>	<p>Enables Legacy USB support. AUTO option disables legacy support if no USB devices are connected. Disable option will keep USB devices available only for EFI applications</p> <hr/> <p>←→: Select Screen ↑↓: Select Item Enter: Select -/+ : Change Opt. F1: General Help F2: Previous Values F3: Optimized Defaults F4: Save & Exit ESC: Exit</p>

USB Configuration Sub-Menu Selections

You can make the following selections on the USB configuration sub-menu.

Feature	Options	Description
Legacy USB enabled	Disabled Enabled	Enables Legacy USB support. AUTO option disables legacy support if no USB devices are connected. DISABLE option will keep USB devices available only for EFI applications.
Usn3.0 Support	Disabled Enabled	Enable/Disable USB3.0 (XHCI) Controller support.
XHCI Hand-off	Disabled Enabled	This is a workaround for Oses without XHCI hand-off support. This XHCI ownership change should be claimed by XHCI driver.
EHCI Hand-off	Disabled Enabled	This is a workaround for Oses without EHCI hand-off support. This EHCI ownership change should be claimed by EHCI driver.

IT8783F Super IO Configuration Sub-Menu

Aptio Setup Utility	
Advanced	
<p>IT8783F Super IO configuration</p> <p>IT8783F Super IO Chip IT8783F</p> <ul style="list-style-type: none"> ▶ Serial Port 0 Configuration ▶ Serial Port 1 Configuration ▶ Serial Port 2 Configuration ▶ Serial Port 3 Configuration 	<p style="color: blue;">Set Parameters of Serial Port 0 (COMA)</p> <hr/> <p style="color: blue;">→←: Select Screen ↑↓: Select Item Enter: Select -/+: Change Opt. F1: General Help F2: Previous Values F3: Optimized Defaults F4: Save & Exit ESC: Exit</p>

IT8783F Super IO Configuration Sub-Menu Selections

You can make the following selections on the IT8783F super IO configuration sub-menu.

Feature	Options	Description
Serial Port	Disabled Enabled	Enable or Disable Serial Port (COM)
Change Settings	Auto IO=3F8h; IRQ=4; IO=3F8h; IRQ=3,45,6,7,10,11,12; IO=2F8h; IRQ=3,45,6,7,10,11,12; IO=3E8h; IRQ=3,45,6,7,10,11,12; IO=2E8h; IRQ=3,45,6,7,10,11,12;	Select an optimal setting for Super IO device.
COM 1 Mode Setting	RS232 RS422 TTL 1 RS485	Change COM port Settings

IT8783F H/W Monitor Sub-Menu

Advanced		Aptio Setup Utility
Pc Health Status		
System temperature1		
System temperature2		
System temperature3		
Fan1 Speed		
Fan2 Speed		
Fan3 Speed		
VIN0		←→: Select Screen
VIN1		↑↓: Select Item
VIN2		Enter: Select
VIN3		-/+ : Change Opt.
VIN4		F1: General Help
VIN5		F2: Previous Values
VIN6		F3: Optimized Defaults
VIN7		F4: Save & Exit
VBAT		ESC: Exit

RF Device Control Configuration Sub-Menu

Advanced		Aptio Setup Utility
<p>RF Device Control</p> <p>GPS STATUS Present GPS [Enabled]</p> <p>BT STATUS Present BLUETOOTH [Enabled]</p> <p>WLAN STATUS Present WLAN [Enabled]</p>	<p>RF Device Control Setting</p> <hr/> <p>→←: Select Screen ↑↓: Select Item Enter: Select -/+: Change Opt. F1: General Help F2: Previous Values F3: Optimized Defaults F4: Save & Exit ESC: Exit</p>	

RF Device Control Configuration Sub-Menu Selections

You can make the following selections on the RF Security Control sub-menu.

Feature	Options	Description
Wireless LAN	Disabled	Wireless Lan Control
	Enabled	Enabled Wireless function
GPS	Disabled	GPS Control
	Enabled	Enabled GPS function
BlueTooth	Disabled	BlueTooth Control
	Enabled	Enabled Blue Tooth function

EC Thermal Control Sub-Menu

Advanced		Aptio Setup Utility
EC Thermal Control		EC Thermal Control Setting
Thermal cooling trip point	[87 C]	
		→←: Select Screen ↑↓: Select Item Enter: Select -/+: Change Opt. F1: General Help F2: Previous Values F3: Optimized Defaults F4: Save & Exit ESC: Exit

USB CHARGE Control Sub-Menu

Advanced		Aptio Setup Utility
USB CHARGE		USB CHARGE Setting
USB CHARGE Control	[Disabled]	
		→←: Select Screen ↑↓: Select Item Enter: Select -/+: Change Opt. F1: General Help F2: Previous Values F3: Optimized Defaults F4: Save & Exit ESC: Exit

Note:

- *USB Charge control is for turn On /Off the USB charge function under S5 state (Power off) when connecting to AC Adapter*
- *When enable USB CHARGE control in BIOS, please cold boot your computer to enable the function.*

Chipset Menu

Aptio Setup Utility		
Main	Advanced	Chipset
<ul style="list-style-type: none"> ▶ System Agent (SA) Configuration ▶ PCH-IO Configuration 		System Agent (SA) Parameters →←: Select Screen ↑↓: Select Item Enter: Select -/+ : Change Opt. F1: General Help F2: Previous Values F3: Optimized Defaults F4: Save & Exit ESC: Exit

Chipset Menu Selections

You can make the following selections on the Chipset sub-menu.

Feature	Options	Description
System Agent (SA) Configuration	Graphics Configuration Memory Configuration	Memory Configuration Parameters
PCH-IO Configuration		PCH Parameter

System Agent Configuration Sub-Menu

Aptio Setup Utility	
Chipset	
<ul style="list-style-type: none"> ▶ Graphics Configuration ▶ Memory Configuration 	Config Graphics Settings →←: Select Screen ↑↓: Select Item Enter: Select -/+ : Change Opt. F1: General Help F2: Previous Values F3: Optimized Defaults F4: Save & Exit ESC: Exit

Graphics Configuration Sub-Menu

Aptio Setup Utility Chipset	
Graphics Configuration IGFX VBIOS VERSION 2137 ▶ LCD Control	LCD Control →←: Select Screen ↑↓: Select Item Enter: Select -/+: Change Opt. F1: General Help F2: Previous Values F3: Optimized Defaults F4: Save & Exit ESC: Exit

LCD Control Sub-Menu

Aptio Setup Utility Chipset	
LCD Control Panel Type [XGA panel – 24 Bit]	Select Panel Type for RK/RF10 →←: Select Screen ↑↓: Select Item Enter: Select -/+: Change Opt. F1: General Help F2: Previous Values F3: Optimized Defaults F4: Save & Exit ESC: Exit

Panel Type Selections

You can make the following selections on the Panel Type sub-menu.

Feature	Options	Description
Panel Type	sXGA Panel - 18Bit XGA Panel - 24 Bit	Select Panel Type for RK/RF10

PCH-IO Configuration Sub-Menu

Aptio Setup Utility Chipset		
Intel PCH RC Version 1.2.2.0 Intel PCH SKU Name QM67 Intel PCH Rev ID 05/B3		Enable or disable onboard NIC.
PCH LAN Controller [Enabled] Wake on LAN [Enabled]		→←: Select Screen ↑↓: Select Item Enter: Select -/+: Change Opt. F1: General Help F2: Previous Values F3: Optimized Defaults F4: Save & Exit ESC: Exit
▶ USB Configuration ▶ PCI Express Configuration		

PCH-IO Configuration Sub-Menu Selections

You can make the following selections on the PCH-IO Configuration sub-menu.

Feature	Options	Description
PCH LAN Controller	Disabled Enabled	Enable or disable onboard NIC.
Wake on LAN	Disabled Enabled	Enable or disable integrated LAN to wake the system
USB Configuration	Disabled Enabled	USB Configuration settings
PCI Express Configuration	Disabled Enabled	PCI Express Configuration settings

Boot Menu

Aptio Setup Utility					
Main	Advanced	Chipset	Boot	Security	Save & Exit
Set Boot Priority 1st Boot Option [USB Floppy] 2nd Boot Option [Hard Disk:] 3rd Boot Option [CD/DVD:] 4th Boot Option [USB CD/DVD] 5th Boot Option [USB Hard Disk] 6th Boot Option [USB KEY] 7th Boot Option [Network:] 8th Boot Option [UEFI]				Set Boot Priority.	
Boot Option Priorities Boot Option #1 [P4:] Boot Option #2 [P3:] Boot Option #3 [IBA GE Slot 00C8 v...] Unknown Device BBS Priorities Unknown Device BBS Priorities Unknown Device BBS Priorities ▶ CD/DVD ROM Driver BBS Priorities ▶ Hard Driver BBS Priorities ▶ Network Device BBS Priorities				→←: Select Screen ↑↓: Select Item Enter: Select -/+ : Change Opt. F1: General Help F2: Previous Values F3: Optimized Defaults F4: Save & Exit ESC: Exit	

The system will try to boot from device on top then the 2nd and so on. If there is more than one device in each category, only the device on top of sub-menu can boot up.

Boot Menu Selections

You can make the following selections on the Boot menu.

Feature	Options	Description
1st~8th Boot	-	Set Boot Priority.
Boot Option #1~#3	-	Set Boot Priority.
Unknown Device BBS Priorities	-	Set the order of the legacy devices in this group
CD/DVD ROM Device BBS Priorities	-	Specifies the Boot Device Priority sequence from available CD/DVD Drives.
Hard Drive BBS Priorities	-	Specifies the Boot Device Priority sequence from available Hard Drives.
Network Device BBS Priorities	-	Specifies the Boot Device Priority sequence from available NETWORK Drives.

Security Menu

Aptio Setup Utility	
Main	Advanced
Chipset	Boot
Security	Save & Exit
<p>Password Description</p> <p>If ONLY the Administrator's password is set, then this only limits access to Setup and is only asked for when entering Setup.</p> <p>If ONLY the User's password is set, then this is a power on password and must be entered to boot or enter Setup. In Setup the User will have Administrator rights.</p> <p>The password length must be in the following range;</p> <p>Minimum length 3</p> <p>Maximum length 20</p> <p>Administrator Password</p> <p>User Password</p> <p>HDD Security Configuration:</p> <p>HDD 0: TOSHIBA MK50</p>	<p>Set Administrator Password</p> <hr/> <p>→←: Select Screen ↑↓: Select Item Enter: Select -/+ : Change Opt. F1: General Help F2: Previous Values F3: Optimized Defaults F4: Save & Exit ESC: Exit</p>

Security Menu Selections

You can make the following selections on the Security Menu.

Feature	Options	Description
Administrator Password	Enter Password Confirm Password	New New
User password	Enter Password Confirm Password	New New
HDD 0:	Enter Password Confirm Password	New New

Save & Exit Menu

Aptio Setup Utility	
Main	Advanced
<p>Save Changes and Exit Discard Changes and Exit Save Changes and Reset Discard Changes and Reset</p> <p>Save Options Save Changes Discard Changes</p> <p>Restore Defaults Save as User Defaults Restore User Defaults</p> <p>Boot Override P4: P3: IBA GE Slot 00C8 v1365</p>	<p>Exit system setup after saving the changes</p> <hr/> <p>→←: Select Screen ↑↓: Select Item Enter: Select -/+ : Change Opt. F1: General Help F2: Previous Values F3: Optimized Defaults F4: Save & Exit ESC: Exit</p>

Chapter Five - Drivers and Applications

The Utility DVD includes all the drivers for the installed devices in your notebook computer. Please consult the dealer if there is any driver missing. Also, through Device Manager in Windows, you are able to perform "Driver Update" or check if there are still drivers for the devices needed to be installed. Please check the readme file on Utility DVD to get the latest information before installing device drivers.

Note:

- *Please install the chipset driver first.*
- *If the system requests for reboot after installing drivers, please reboot your notebook computer first before installing other drivers.*

Chipset

Windows 7/Ultimate 64-bit:

Run "Setup.exe" in the directory of "\\Drivers\Windows 7 (64-bit)\Intel_Chipset", and then follow the instructions to install.

Windows 7/Ultimate 32-bit:

Run "Setup.exe" in the directory of "\\Drivers\Windows 7 (32-bit)\Intel_Chipset", and then follow the instructions to install.

Windows 8/Ultimate 64-bit:

Run "infinst_autol.exe" in the directory of "\\Drivers\Windows 8 (64-bit)\Intel_Chipset", and then follow the instructions to install.

Windows 8/Ultimate 32-bit:

Run "infinst_autol.exe" in the directory of "\\Drivers\Windows 8 (32-bit)\Intel_Chipset", and then follow the instructions to install.

VGA**Windows 7/Ultimate 64-bit:**

Run "win64_15288.exe" in the directory of "\\Drivers\Windows 7 (64-bit)\Intel_VGA", and then follow the instructions to install.

Windows 7/Ultimate 32-bit:

Run "win64_15288.exe" in the directory of "\\Drivers\Windows 7 (32-bit)\Intel_VGA", and then follow the instructions to install.

Windows 8/Ultimate 64-bit:

Run "win64_152812.exe" in the directory of "\\Drivers\Windows 8 (64-bit)\Intel_VGA\64bit", and then follow the instructions to install.

Windows 8/Ultimate 32-bit:

Run "win32_152812.exe" in the directory of "\\Drivers\Windows 8 (32-bit)\Intel_VGA", and then follow the instructions to install.

Audio**Windows 7/Ultimate 64-bit:**

Run "Setup.exe" in the directory of "\\Drivers\Windows 7 (64-bit)\Audio\6777_PG360_Win8_Win7_Vista_XP", and then follow the instructions to install.

Windows 7/Ultimate 32-bit:

Run "Setup.exe" in the directory of "\\Drivers\Windows 7 (32-bit)\Audio\6777_PG360_Win8_Win7_Vista_XP", and then follow the instructions to install.

Windows 8/Ultimate 64-bit:

Run "Setup.exe" in the directory of "\\Drivers\Windows 8 (64-bit)\Audio\6777_PG360_Win8_Win7_Vista_XP", and then follow the instructions to install.

Windows 8/Ultimate 32-bit:

Run "Setup.exe" in the directory of "\\Drivers\Windows 8 (32-bit)\Audio\6777_PG360_Win8_Win7_Vista_XP", and then follow the instructions to install.

Intel ME**Windows 7/Ultimate 64-bit:**

Run "Setup.exe" in the directory of " \Drivers\Windows 7 (64-bit)\Intel_ME\ME_SW_7.1.85.1216", and then follow the instructions to install.

Windows 7/Ultimate 32-bit:

Run "Setup.exe" in the directory of "\Drivers\Windows 7 (32-bit)\Intel_ME\ME_SW_7.1.85.1216", and then follow the instructions to install.

Windows 8/Ultimate 64-bit:

Run "Setup.exe" in the directory of " \Drivers\Windows 8 (64-bit)\Intel_ME\ME_SW_7.1.85.1216", and then follow the instructions to install.

Windows 8/Ultimate 32-bit:

Run "Setup.exe" in the directory of " \Drivers\Windows 8 (32-bit)\Intel_ME\ME_SW_7.1.85.1216", and then follow the instructions to install.

Intel Rapid Storage Technology**Windows 7/Ultimate 64-bit:**

Run "iata_cd_10.8.0.1003.exe" in the directory of "Drivers\Windows 7 (64-bit)\IntelR Rapid Storage Technology", and then follow the instructions to install.

Windows 7/Ultimate 32-bit:

Run "iata_cd_10.8.0.1003.exe" in the directory of "Drivers\Windows 7 (32-bit)\IntelR Rapid Storage Technology", and then follow the instructions to install.

Windows 8/Ultimate 64-bit:

Run "iata_cd.exe" in the directory of "Drivers\Windows 8 (64-bit)\IntelR Rapid Storage Technology", and then follow the instructions to install.

Windows 8/Ultimate 32-bit:

Run "iata_cd.exe" in the directory of "Drivers\Windows 8 (32-bit)\IntelR Rapid Storage Technology", and then follow the instructions to install.

Wireless Power Manager

Windows 7/Ultimate 64-bit:

Run "setup.exe" in the directory of "\\Utilities\0107\", and then follow the instructions to install.

Windows 7/Ultimate 32-bit:

Run "setup.exe" in the directory of "\\Utilities\0107\", and then follow the instructions to install.

Windows 8/Ultimate 64-bit:

Run "setup.exe" in the directory of "\\Utilities\0620\", and then follow the instructions to install.

Windows 8/Ultimate 32-bit:

Run "setup.exe" in the directory of "\\Utilities\0620\", and then follow the instructions to install.

Touch Screen

Windows 7/Ultimate 64-bit:

Run "setup.exe" in the directory of "\\Drivers\Windows 7 (64-bit)\Touch Screen\PenMount Windows Universal Driver V2.4.0.306(WHQL)", and then follow the instructions to install.

Windows 7/Ultimate 32-bit:

Run "setup.exe" in the directory of "\\Drivers\Windows 7 (32-bit)\Touch Screen\PenMount Windows Universal Driver V2.4.0.306(WHQL)", and then follow the instructions to install.

Windows 8/Ultimate 64-bit:

Run "setup.exe" in the directory of "\\Drivers\Windows 8 (64-bit)\Touch Screen\PenMount Windows Universal Driver V2.4.0.306(WHQL)", and then follow the instructions to install.

Windows 8/Ultimate 32-bit:

Run "setup.exe" in the directory of "\\Drivers\Windows 8 (32-bit)\Touch Screen\PenMount Windows Universal Driver V2.4.0.306(WHQL)", and then follow the instructions to install.

USB3.0**Windows 7/Ultimate 64-bit:**

Run "Texas Instruments xHCI Driver v1.12.25 (Multilanguage - WHQL).exe" in the directory of "\\Drivers\Windows 7 (64-bit)\USB3.0\Texas Instruments xHCI Driver v1.12.25 (Multilanguage - WHQL)", and then follow the instructions to install.

Windows 7/Ultimate 32-bit:

Run "Texas Instruments xHCI Driver v1.12.25 (Multilanguage - WHQL).exe" in the directory of "\\Drivers\Windows 7 (32-bit)\USB3.0\Texas Instruments xHCI Driver v1.12.25 (Multilanguage - WHQL)", and then follow the instructions to install.

Windows 8/Ultimate 64-bit:

Run
"Texas_Instruments_xHCI_Driver_v1.16.2.0_WHQL_(Multilanguage).exe" in
the directory of "\\Drivers\Windows 7
(64-bit)\USB3.0\Texas_Instruments_xHCI_Driver_v1.16.2.0_WHQL_(Multilan
guage)", and then follow the instructions to install.

Windows 8/Ultimate 32-bit:

Run
"Texas_Instruments_xHCI_Driver_v1.16.2.0_WHQL_(Multilanguage).exe" in
the directory of "\\Drivers\Windows 8
(32-bit)\USB3.0\Texas_Instruments_xHCI_Driver_v1.16.2.0_WHQL_(Multilan
guage)", and then follow the instructions to install.

Ricoh SD Controller**Windows 7/Ultimate 64-bit:**

Run "setup.exe" in the directory of "\\Drivers\Windows 7 (64-bit)\Ricoh\Ricoh_Media_Driver_v2.13.16.01", and then follow the instructions to install.

Windows 7/Ultimate 32-bit:

Run "setup.exe" in the directory of "\\Drivers\Windows 7 (32-bit)\Ricoh\Ricoh_Media_Driver_v2.13.16.01", and then follow the instructions to install.

Windows 8/Ultimate 64-bit:

Run "setup.exe" in the directory of "\\Drivers\Windows 8 (64-bit)\Ricoh\Ricoh_Media_Driver_v2.24.12.11", and then follow the instructions to install.

Windows 8/Ultimate 32-bit:

Run "setup.exe" in the directory of "\\Drivers\Windows 8 (32-bit)\Ricoh\Ricoh_Media_Driver_v2.24.12.11", and then follow the instructions to install.

Turbo Boost Monitor**Windows 7/Ultimate 64-bit:**

Run "setup.exe" in the directory of "\\Drivers\Windows 7 (64-bit)\IntelR Turbo Boost Technology Monitor", and then follow the instructions to install.

Windows 7/Ultimate 32-bit:

Run "setup.exe" in the directory of "\\Drivers\Windows 7 (32-bit)\IntelR Turbo Boost Technology Monitor", and then follow the instructions to install.

Windows 8/Ultimate 64-bit:

Run "setup.exe" in the directory of "\\Drivers\Windows 8 (64-bit)\IntelR Turbo Boost Technology Monitor", and then follow the instructions to install.

Windows 8/Ultimate 32-bit:

Run "setup.exe" in the directory of "\\Drivers\Windows 8 (32-bit)\IntelR Turbo Boost Technology Monitor", and then follow the instructions to install.

Gigabit LAN

Windows 7/Ultimate 64-bit:

Run "PROWinx64.exe" in the directory of "\\Drivers\Windows 7 (64-bit)\Intel_82579LM", and then follow the instructions to install.

Windows 7/Ultimate 32-bit:

Run "PROWinx32.exe" in the directory of "\\Drivers\Windows 7 (32-bit)\Intel_82579LM", and then follow the instructions to install.

Windows 8/Ultimate 64-bit:

Run "PROWinx64.exe" in the directory of "\\Drivers\Windows 8 (64-bit)\Intel_82579", and then follow the instructions to install.

Windows 8/Ultimate 32-bit:

Run "PROWinx32.exe" in the directory of "\\Drivers\Windows 8 (32-bit)\Intel_82579", and then follow the instructions to install.

WiFi (Option)

Windows 7/Ultimate 64-bit:

Run "Wireless_15.3.1_Ds64.exe" in the directory of "\\Drivers\Windows 7 (64-bit)\Intel_WiFi6235\WLAN\64bit", and then follow the instructions to install.

*: Then into the "Wireless Power Manager" to turn on the WLAN device.

Windows 7/Ultimate 32-bit:

Run "Wireless_15.3.1_Ds32.exe" in the directory of "\\Drivers\Windows 7 (32-bit)\Intel_WiFi6235\WLAN\32bit", and then follow the instructions to install.

*: Then into the "Wireless Power Manager" to turn on the WLAN device.

Windows 8/Ultimate 64-bit:

Run "Wireless_15.6_De64.exe" in the directory of "\\Drivers\Windows 8 (64-bit)\Intel_WiFi6235\WLAN\64bit", and then follow the instructions to install.

*: Then into the "Wireless Power Manager" to turn on the WLAN device.

Windows 8/Ultimate 32-bit:

Run "Wireless_15.6_De32.exe" in the directory of "\\Drivers\Windows 8 (32-bit)\Intel_WiFi6235\WLAN\", and then follow the instructions to install.

*: Then into the "Wireless Power Manager" to turn on the WLAN device.

Bluetooth (Option)

Windows 7/Ultimate 64-bit:

*: First into the "Wireless Power Manager" to turn on the Bluetooth device.

Run "BT_2.2_s64.exe" in the directory of "\Drivers\Windows 7 (64-bit)\Intel_WiFi6235\BT\64bit", and then follow the instructions to install.

Windows 7/Ultimate 32-bit:

*: First into the "Wireless Power Manager" to turn on the Bluetooth device.

Run "BT_2.2_s32.exe" in the directory of "\Drivers\Windows 7 (32-bit)\Intel_WiFi6235\BT\32bit", and then follow the instructions to install.

Windows 8/Ultimate 64-bit:

*: First into the "Wireless Power Manager" to turn on the Bluetooth device.

Run "BT_2.6.1211_e64.exe" in the directory of "\Drivers\Windows 8 (64-bit)\Intel_WiFi6235\BT\64bit", and then follow the instructions to install.

Windows 8/Ultimate 32-bit:

*: First into the "Wireless Power Manager" to turn on the Bluetooth device.

Run "BT_2.6.1211_e32.exe" in the directory of "\Drivers\Windows 7 (32-bit)\Intel_WiFi6235\BT\", and then follow the instructions to install.

GPS (Option)

Windows 7/Ultimate 64-bit:

*: First into the "Wireless Power Manager" to turn on the GPS device.

Run "ublox_A4_U5_USB_drv3264_install_UI.exe" in the directory of "\Drivers\Windows 7 (64-bit)\UBlox 6H Driver", and then follow the instructions to install.

Windows 7/Ultimate 32-bit:

*: First into the "Wireless Power Manager" to turn on the GPS device.

Run "ublox_A4_U5_USB_drv3264_install_UI.exe" in the directory of "\Drivers\Windows 7 (32-bit)\UBlox 6H Driver", and then follow the instructions to install.

Windows 8/Ultimate 64-bit:

*: First into the "Wireless Power Manager" to turn on the GPS device.

Run "ublox_A4_U5_USB_drv3264_install_UI.exe" in the directory of "\Drivers\Windows 8 (64-bit)\UBlox 6H Driver", and then follow the instructions to install.

Windows 8/Ultimate 32-bit:

*: First into the "Wireless Power Manager" to turn on the GPS device.

Run "ublox_A4_U5_USB_drv3264_install_UI.exe" in the directory of "\Drivers\Windows 8 (32-bit)\UBlox 6H Driver", and then follow the instructions to install.

TPM (Option)

Windows 7/Ultimate 64-bit:

*: First into the "BIOS" to turn on the TPM device.

Run "setup.exe" in the directory of "\\Drivers\Windows 7 (64-bit)\TPM", and then follow the instructions to install.

Windows 7/Ultimate 32-bit:

*: First into the "BIOS" to turn on the TPM device.

Run "setup.exe" in the directory of "\\Drivers\Windows 7 (32-bit)\TPM", and then follow the instructions to install.

Windows 8/Ultimate 64-bit:

*: First into the "BIOS" to turn on the TPM device.

Run "setup.exe" in the directory of "\\Drivers\Windows 8 (64-bit)\TPM", and then follow the instructions to install.

Windows 8/Ultimate 32-bit:

*: First into the "BIOS" to turn on the TPM device.

Run "setup.exe" in the directory of "\\Drivers\Windows 8 (32-bit)\TPM", and then follow the instructions to install.

Chapter Six - Specifications

Platform

- Intel® Huron River Platform

CPU

- Intel® Sandy Bridge i7-2610UE
(4 MB Intel Smart Cache Memory)

CPU runs at multiple speeds depending on the CPU type and operating system. Also, CPU speed switches automatically by detecting AC adapter/ battery operation and busy state.

PCH

- Intel® Cougar Point QM67

Memory

- Max. 16GB System Memory
 - Industrial grade
 - DDR3 SO-DIMM x 2, 1333MHz

Display

- 13.3" XGA LCD with CCFL
 - Resolution: 1024 x 768
 - Brightness (min. ~ typ.): 380~480 nits
 - Anti-Reflection

Keyboard

- Number of keys: 87 Keys (standard 87-key w/o backlight)
89 keys (optional rubber 89-key with backlight)
- Key Travel: 2.8 mm (standard 87-key w/o backlight)
1.5 mm (optional rubber 89-key with backlight)

Touchpad

- Type: PS/2 Resistive Touchpad
- Life time: Over 5,000,000 strokes lifetime

Hard Disk Drive (HDD) / Optional Solid State Drive (SSD)

- Type: 2.5" (Removable)
- Height: 9.5mm / 7mm
- Interface: SATA II

Optical Disk Drive (ODD)

- Type: 5.25" (Removable)
- Height: 12.7mm
- Interface: SATA II

I/O Ports

Left Side:

- PS/2 x1 (KB + mouse)
- USB 2.0 x 3
- IEEE1394a (Fire Wire) x 1
- GLAN RJ45 x 1
- 2nd GLAN RJ45 x 1
- Audio Jack x 3 (Line-in, Microphone, Headphone)
- Express Card (PCI-e) x 1
- PCMCIA x 1
- Serial Port DB9 x 2 (COM3/4)

Rear Side:

- Serial Port DB9 x 2 (COM1/2)
- DC Jack x 1 (Military DC Jack)
- Printer Port x 1
- VGA Port x 1
- Docking Port x 1
- Optional: Military Connector Port x 2

Note:

- *The max. baud rate for COM port supports to 115,200 bps.*

AC Adapter

- AC Input: 100 - 240 V
- Frequency: 50/60 Hz
- DC Output: 19V
- Maximum Power: 90 Watts Max. Output
- Dimension: 130mm (W) x 60mm (D) x 34mm (H)
- Weight: 430 g (0.9 lb.)

Battery

Primary Battery:

- Type: 9 x 18650 cells Lithium Ion
- Capacity: 11.1V 8700mAh
- Dimension: 103 mm (W) x 73 mm (D) x 38 mm (H)
- Weight: 435 g

2nd Battery (Optional):

- Type: 9 x 18650 cells Lithium Ion
- Capacity: 11.1V 8700mAh
- Dimension: 137 mm (W) x 170 mm (D) x 22 mm (H)
- Weight: 560 g

Note:

- *2nd battery is trade-off with ODD.*

System Unit Dimensions and Weight

- Dimensions (mm):
312 (L) x 246 (W) x 66.7 (H) (without Bumpers)
324 (L) x 258 (W) x 79.7 (H) (with Bumpers)
- Weight: 5Kg (including ODD and Primary battery)

Note:

- *Weight includes Primary battery, HDD, and ODD. Weight varies depending on system configurations.*

Materials and Recycling

Materials of the computer are as follows:

- Cabinet: Aluminum Alloy ADC-12
Magnesium Alloy AZ91D
UL grade PC+ABS GE C6200 or TN-3813BW
- Bracket: Aluminum 5052
Steel with Nickel Plating or Stainless Steel S304
- Cushion pad: Silicon Rubber
TPE
- PCB: FR-4
UL 94V0
- Battery: Rechargeable Lithium Ion, 9 Cells per Pack
- Packing: Carton - Unbleached Paper
Cushion - Recyclable EPE
Carrying bag - Recyclable PE Fiber
Quick Guide - Recycled/Recyclable Paper

Please recycle the parts according to the local regulations.

Environmental

- | | | |
|----------------|------------------------------------|-----------|
| ● Temperature: | -20 ~ +55°C (-4 ~ +131°F) | operating |
| | -40 ~ +70°C (-40 ~ +158°F) | storage |
| ● Humidity: | 5~95% Non-condensing | operating |
| | 95% maximum | storage |
| ● Altitude: | 0 ~ 4,572 meters (0 ~ 15,000 feet) | operating |

Chapter Seven - Optional Devices

Communication

- WiFi/Bluetooth:
 - Intel® Centrino® Advanced-N 6235, Dual Band
 - Board Form Factor: PCIe Half Mini Card
 - Wi-Fi Certified: 802.11 a/b/g/n
 - Bluetooth: Supports BT 2.1, 2.1+EDR, 3.0, 3.0+HS, 4.0 (BLE)
 - Interface: PCIe (WiFi)/USB (BT)
- GPS:
 - U-blox LEA-6H (USB interface)
 - Supporting both GPS and GALILEO systems

Memory Card

The memory card will expand your memory to facilitate better system performance. Industrial grade DDR3 SO-DIMM x 2 is available, supporting 4GB or 8GB DDR3 1333 memory cards. The maximum capacity is 16GB.

Touch Screen

The touch screen supports single touch function, featuring in normal or sunlight readable.

Surge Protector/BVA Module

Surge protector and BVA functions are integrated into one module in the computer. The module features in converting power from car lighters or truck batteries to DC +19V and contains the reverse polarity protection and the clamping of high voltage input.

Vehicle Adapter

- EVA1275 External Vehicle Adaptor
 - DC Input Range: 12 ~ 32 V
 - DC Output Voltage: 19 V
 - Output Current: 5 A (at 28 V Input Voltage)
 - Ripple Voltage: 200 mA
 - Input Reverse Voltage Protection
 - Output Overvoltage Protection
 - Short-Circuit Protection and Current Limit
 - Complying with MIL-461F
 - Complying with MIL-1275D

- EVA19040 External Vehicle Adaptor
 - DC Input Range: 12 ~ 32 V
 - DC Output Voltage: 19 V
 - Output Current: 4 A (at 28 V Input Voltage)
 - Ripple Voltage: 200 mA
 - Output Overvoltage Protection
 - Short-Circuit Protection and Current Limit
 - Complying with MIL-461F

2nd Battery

Trade-off with ODD, a Lithium Ion rechargeable 2nd battery may install into the ODD-compartment. It shares the same capacity of primary battery and smart battery compliance.

The computer's internal charger can detect 2nd battery and perform charging accordingly.

2nd HDD

- Trade-off with ODD; set as SATA primary slave drive.

ODD

- Removable ODD for disks playing
- Compatible with VCD-ROM, DVD-ROM, and etc.

KB Dust Cover

- KB Dust Cover is available for standard Keyboard

Dual Battery Charger RT202D

This charger provides two bays for the **Primary** and **Secondary Batteries** respectively. It accepts power from AC adapter or vehicle adapter and charged batteries.

Trust Platform Module (TPM)

There is an optional Trust Platform Module (TPM) equipped with this notebook computer for users to strengthen the security. The TPM module can support to -20°C environment of operating temperature.

With TPM, users are able to encrypt the folders and files directly and make the important file be more secure and be with an additional protection. In other words, your TPM-encrypted files are basically protected with two layers. Even if your TPM-encrypted files are hacked, the files can not to be read without passwords and TPM chipset.

Chapter Eight - Maintenance and Service

Cleaning

ALWAYS turn OFF the power, unplug the power cord and remove the battery before cleaning.

The exterior of the system and display may be wiped with a clean, soft, and lint-free cloth. If there is difficulty removing dirt, apply non-ammonia, non-alcohol based glass cleaner to the cloth and wipe.

An air gun is recommended for cleaning water and dust. For salty water please clean with fresh water then blow-dry with an air gun. Be sure not to turn the computer upside down while there is water being applied.

Troubleshooting

Should the computer fail to function properly, the troubleshooting steps below may be followed.

- Check AC/vehicle adapter, battery, and the power source.
- Minimize the configuration, i.e. remove extra peripherals and devices.
- Remove the modules one by one (HDD, ODD, Battery, etc.).
- Remove the software suspected.
- Set BIOS fail-safe default.
- Re-install operating system and application software.

RMA Service

If troubleshooting steps are unsuccessful, consult your dealer for RMA.

Shipping instructions:

1. Remove any personal disks or other media.
2. Use the original shipping container and packing materials, if possible.
3. If the original packing materials are not available, wrap the equipment with soft material (e.g. PU/PE form) then put the wrapped equipment into a hard cardboard shipping box.
4. Include a sheet with the following information: (Note: Please keep a copy of this sheet for your records)
 - Name
 - Address
 - Unit serial number
 - Place and date of purchase or the original invoice number
 - Date of failure
 - A DETAILED Description of the problems you have encountered
 - A list of the hardware/software configuration, if applicable.
5. Clearly mark the outside of the shipping box with the RMA #. If RMA # is not present on the shipping box, receiving will be unable to identify it and it might be returned.
6. Unless prior arrangements have been made, the customer is responsible for all shipping costs. Unauthorized use of the company's shipping accounts is not permitted.