



Miller[®]

February 1996 Form: TM-428
Effective With Serial No. JH242114

TECHNICAL MANUAL

Service And Parts

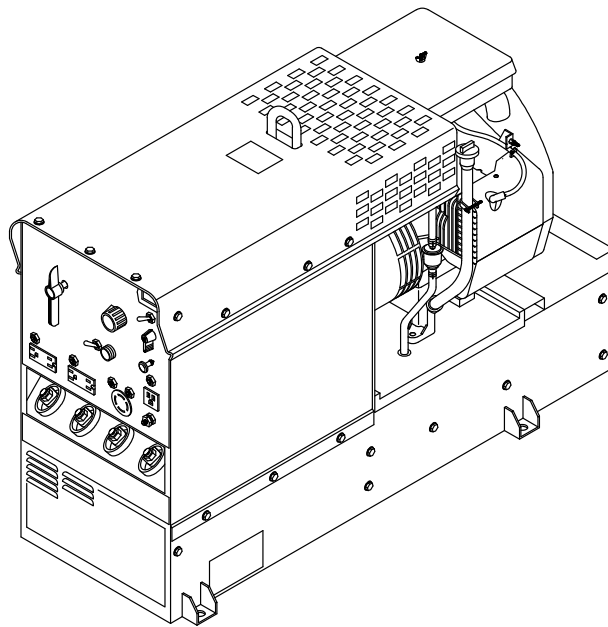

Miller Legend[®]

(Formerly The Legend[™] AEAD-200LE)

CC AC/DC Welding Generator For SMAW, GMAW, GTAW Welding

Welding Mode	Weld Output Range	Rated Welding Output	Maximum Open-Circuit Voltage	Auxiliary Power Rating	Fuel Capacity	Engine
CC/AC	35 – 225 A	225 A, 25 V, 100% Duty Cycle	80	Single-Phase, 5 kVA/kW, 42/21 A, 120/240 V AC, 60 Hz And	7.5 gal (28 L) Tank	Onan P218 Air-Cooled, Two-Cylinder, Four-Cycle, Gasoline Engine
CC/DC	25 – 200 A	200 A, 25 V, 100% Duty Cycle	72	Single-Phase, 1 kVA/kW, 9 A, 115 V AC, 100 Hz		

TABLE OF CONTENTS

SECTION 1 – SAFETY PRECAUTIONS FOR SERVICING	1
1-1. Symbol Usage	1
1-2. Servicing Hazards	1
1-3. EMF Information	2
SECTION 2 – INSTALLATION	3
2-1. Installing Welding Generator	3
2-2. Dimensions, Weights, And Operating Angles	3
2-3. Fuel Consumption	4
2-4. Engine Prestart Checks	4
2-5. Connecting The Battery	5
2-6. Connecting To Weld Output Terminals	5
2-7. Selecting Weld Cable Sizes	6
2-8. Remote 14 Receptacle RC1 Information	6
SECTION 3 – OPERATING WELDING GENERATOR	7
3-1. Front Panel Controls	7
3-2. Remote Control (Optional)	8
3-3. Duty Cycle	8
3-4. Volt-Ampere Curves	9
SECTION 4 – OPERATING AUXILIARY EQUIPMENT	10
4-1. 100 Hz Auxiliary Power Receptacle And Circuit Breaker	10
4-2. AC Auxiliary Power Curve	10
4-3. 60 Hz Auxiliary Power Receptacles And Circuit Breakers	11
SECTION 5 – THEORY OF OPERATION	12
SECTION 6 – TROUBLESHOOTING	15
6-1. Troubleshooting Tables	15
6-2. Troubleshooting Circuit Diagram For Welding Generator	18
6-3. Troubleshooting Circuit Diagram For Welding Generator With Optional Remote Control ..	20
6-4. Waveforms For Sections 6-2 And 6-3	22
6-5. Idle Control Board/Module PC1 Testing Information	23
6-6. Troubleshooting Flowcharts For Idle Control Board/Module PC1	24
6-7. Voltage Regulator Board PC2 Testing Information Prior To Serial No. KE604176	26
6-8. Voltage Regulator Board PC2 Test Point Values Prior To Serial No. KE604176	26
6-9. Voltage Regulator Board PC2 Testing Information Effective With Serial No. KE604176 ...	27
6-10. Voltage Regulator Board PC2 Test Point Values Effective With Serial No. KE604176	27
6-11. Optional Remote Control Board PC3 Testing Information	28
6-12. Optional Remote Control Board PC3 Test Point Values	28
6-13. Optional Remote Capacitor Board PC5 Testing Information Effective With Serial No. KD346698	29
6-14. Optional Remote Capacitor Board PC5 Test Point Values Effective With Serial No. KD346698	29
6-15. Replacing Brushes And Cleaning Slip Rings	30
6-16. Checking Unit Output After Servicing	32

WHO DO I CONTACT FOR HELP?



■ **CALL:**
Miller Customer Service
Department at
414-735-4505



■ **FAX:**
800-637-2348 (in USA),
or
414-735-4136 (outside USA)



■ **WRITE:**
Miller Electric Mfg. Co.
P.O. Box 1079
Appleton, WI 54912 USA

Always provide Model Name and Serial or Style Number

SECTION 7 – DISASSEMBLY AND REASSEMBLY	33
7-1. Disassembly Of Unit	33
7-2. Disassembly Of Generator	34
SECTION 8 – MAINTENANCE	35
8-1. Routine Maintenance	35
8-2. Maintenance Label	36
8-3. Servicing Air Cleaner	37
8-4. Changing Engine Oil, Oil Filter, And Fuel Filter	38
8-5. Adjusting Engine Speed	39
8-6. Overload Protection	40
8-7. Inspecting And Cleaning Optional Spark Arrestor	40
SECTION 9 – ELECTRICAL DIAGRAMS	41
SECTION 10 – PARTS LIST	51

SECTION 1 – SAFETY PRECAUTIONS FOR SERVICING



safety_rtm1 4/95

1-1. Symbol Usage

	<p>Means Warning! Watch Out! There are possible hazards with this procedure! The possible hazards are shown in the adjoining symbols.</p>	<p>▲ Marks a special safety message. ☞ Means NOTE; not safety related.</p>
	<p>This group of symbols means Warning! Watch Out! possible ELECTRIC SHOCK, MOVING PARTS, and HOT PARTS hazards. Consult symbols and related instructions below for necessary actions to avoid the hazards.</p>	

1-2. Servicing Hazards

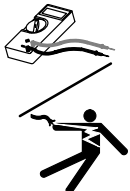
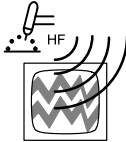
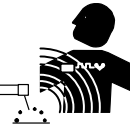
WARNING	
<p>The symbols shown below are used throughout this manual to call attention to and identify possible hazards. When you see the symbol, watch out, and follow the related instructions to avoid the hazard.</p> <p>Only qualified persons should service, test, maintain, and repair this unit.</p> <p>During servicing, keep everybody, especially children, away.</p>	
	<p>ELECTRIC SHOCK can kill.</p> <ol style="list-style-type: none"> Do not touch live electrical parts. Stop engine before testing or repairing unit unless the procedure specifically requires an energized unit. Insulate yourself from ground by standing or working on dry insulating mats big enough to prevent contact with the ground. Do not leave live unit unattended. When testing live unit, use the one-hand method. Do not put both hand inside unit. Keep one hand free.
	<p>ENGINE FUEL can cause fire or explosion.</p> <ol style="list-style-type: none"> Stop engine before fueling. Do not fuel while smoking or near sparks or flames. Do not overfill tank; clean up any spilled fuel.
	<p>MOVING PARTS can cause injury.</p> <ol style="list-style-type: none"> Keep away from moving parts such as fans, belts, and rotors. Have only qualified people remove guards or covers for maintenance and troubleshooting as necessary. Keep hands, hair, loose clothing, and tools away from moving parts. Before working on generator, remove spark plugs or injectors to keep engine from kicking back or starting. Block flywheel so that it will not turn while working on generator components. Reinstall panels or guards and close doors when servicing is finished and before starting engine.
	<p>BATTERY EXPLOSION can BLIND and INJURE.</p> <ol style="list-style-type: none"> Always wear a face shield when working on a battery. Stop engine before disconnecting or connecting battery cables. Do not allow tools to cause sparks when working on a battery. Do not use welder to charge batteries or jump start vehicles. Observe correct polarity (+ and -) on batteries.
	<p>FLYING PIECES OF METAL or DIRT can cause injury.</p> <ol style="list-style-type: none"> Always wear safety glasses with side shields or face shield during servicing. Be careful not to short metal tools, parts, or wires together during testing and servicing.
	<p>BATTERY ACID can BURN SKIN.</p> <ol style="list-style-type: none"> Do not tip. Replace damaged battery. Flush eyes and skin immediately with water.
	<p>STATIC ELECTRICITY can damage parts on circuit boards.</p> <ol style="list-style-type: none"> Put on grounded wrist strap BEFORE handling boards or parts. Use proper static-proof bags to store, move, or ship PC boards.
	<p>STEAM AND PRESSURIZED HOT COOLANT can burn face, eyes, and skin.</p> <ol style="list-style-type: none"> Check coolant level when engine is cold to avoid scalding. If the engine is warm and checking is needed, follow steps 3 and 4. Wear safety glasses and gloves and put a rag over cap. Turn cap slightly and let pressure escape slowly before completely removing cap.
	<p>ENGINE EXHAUST GASES can kill.</p> <ol style="list-style-type: none"> Do not breathe exhaust fumes. Use in open, well-ventilated areas, or vent exhaust outside and away from any building air intakes.
	<p>FALLING EQUIPMENT can cause serious personal injury and equipment damage.</p> <ol style="list-style-type: none"> Use equipment of adequate capacity to lift components. Use a lifting eye to lift unit only, NOT running gear, gas cylinders, or any other accessories. Securely attach components to lifting equipment.

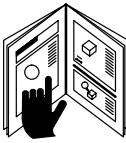
	<p>HOT PARTS can cause severe burns.</p> <ol style="list-style-type: none"> 1. Allow cooling period before servicing. 2. Wear protective gloves and clothing when working on a hot engine. 		<p>HIGH-FREQUENCY RADIATION can interfere with radio navigation, safety services, computers, and communications equipment.</p>
	<p>ELECTRIC SHOCK HAZARD from incorrect use of test equipment.</p> <ol style="list-style-type: none"> 1. Stop engine before making or changing meter lead connections. 2. At least one meter lead should be a self-retaining spring clip such as an alligator clamp. 3. Read instructions for test equipment. 		<ol style="list-style-type: none"> 1. Have only qualified persons familiar with electronic equipment perform this installation. 2. The user is responsible for having a qualified electrician promptly correct any interference problem resulting from the installation. 3. If notified by the FCC about interference, stop using the equipment at once. 4. Have the installation regularly checked and maintained. 5. Keep high-frequency source doors and panels tightly shut, keep spark gaps at correct setting, and use grounding and shielding to minimize the possibility of interference.
	<p>MAGNETIC FIELDS FROM HIGH CURRENTS can affect pacemaker operation.</p> <ol style="list-style-type: none"> 1. Pacemaker wearers keep away from servicing areas until consulting your doctor. 		
	<p>UNCONTROLLED TILTING OR TIPPING OF UNIT can result in personal injury and equipment damage.</p> <ol style="list-style-type: none"> 1. Do not put any body part under unit while lifting. 2. Use adequate blocks to support components as needed during job. <p>PINCH POINTS can injure.</p> <ol style="list-style-type: none"> 1. Be careful when working on stator and rotor assemblies. 		<p>READ INSTRUCTIONS.</p> <ol style="list-style-type: none"> 1. Use MILLER Testing Booklet (Part No. 150 853) when servicing this unit. 2. Consult the Owner's Manual for welding safety precautions. 3. Use only genuine MILLER replacement parts. 4. Reinstall injectors and bleed air from fuel system according to engine manual.

1-3. EMF Information

<p>Considerations About Welding And The Effects Of Low Frequency Electric And Magnetic Fields</p> <p>The following is a quotation from the General Conclusions Section of the U.S. Congress, Office of Technology Assessment, <i>Biological Effects of Power Frequency Electric & Magnetic Fields – Background Paper</i>, OTA-BP-E-53 (Washington, DC: U.S. Government Printing Office, May 1989): “. . . there is now a very large volume of scientific findings based on experiments at the cellular level and from studies with animals and people which clearly establish that low frequency magnetic fields can interact with, and produce changes in, biological systems. While most of this work is of very high quality, the results are complex. Current scientific understanding does not yet allow us to interpret the evidence in a single coherent framework. Even more frustrating, it does not yet allow us to draw definite conclusions about questions of possible risk or to offer clear science-based advice on strategies to minimize or avoid potential risks.”</p>	<p>To reduce magnetic fields in the workplace, use the following procedures:</p> <ol style="list-style-type: none"> 1. Keep cables close together by twisting or taping them. 2. Arrange cables to one side and away from the operator. 3. Do not coil or drape cables around the body. 4. Keep welding power source and cables as far away as practical. 5. Connect work clamp to workpiece as close to the weld as possible. <p>About Pacemakers:</p> <p>The above procedures are also recommended for pacemaker wearers. Consult your doctor for complete information.</p>
--	---

SECTION 2 – INSTALLATION

2-1. Installing Welding Generator

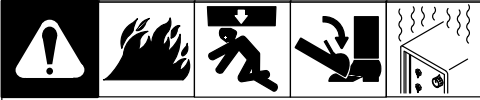

Movement

▲ Do Not Lift Unit From End

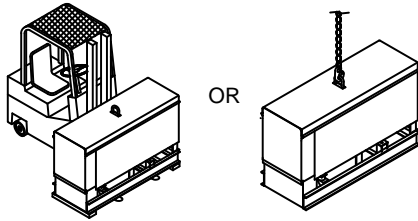

Airflow

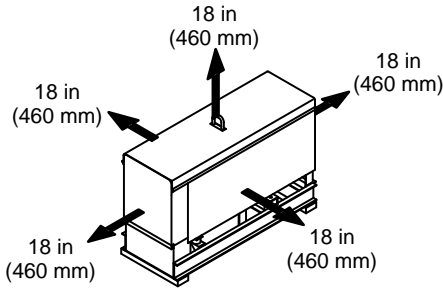

Location

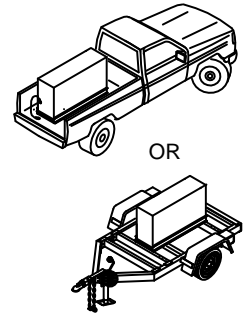

Grounding

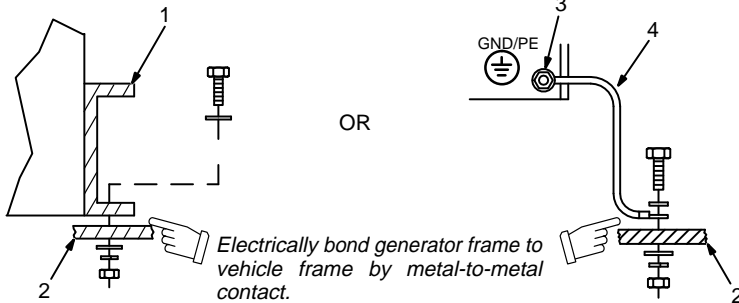

Electrically bond generator frame to vehicle frame by metal-to-metal contact.

- 1 Generator Base
- 2 Metal Vehicle Frame
- 3 Equipment Grounding Terminal
- 4 Grounding Cable

Use #10 AWG or larger insulated copper wire.

▲ If unit does not have GFCI receptacles, use GFCI-protected extension cord.

install1 10/95 – Ref. ST-800 652 / Ref. ST-800 477-A / ST-158 936-A / S-0854

2-2. Dimensions, Weights, And Operating Angles

<p>Engine End</p>	Dimensions		<p>▲ Do not exceed operating angles while running or engine damage will occur.</p> <p>▲ Do not move or operate unit where it could tip.</p>
	Height	31-5/8 in (803 mm)	
	Width	18 in (457 mm)	
	Depth	45 in (1143 mm)	
	A	16-1/2 in (419 mm)	
	B	32-3/4 in (832 mm)	
	C	13/16 in (21 mm) Dia.	
	Weight		
	Net	559 lb (254 kg)	
	Ship	600 lb (272 kg)	

2-3. Fuel Consumption

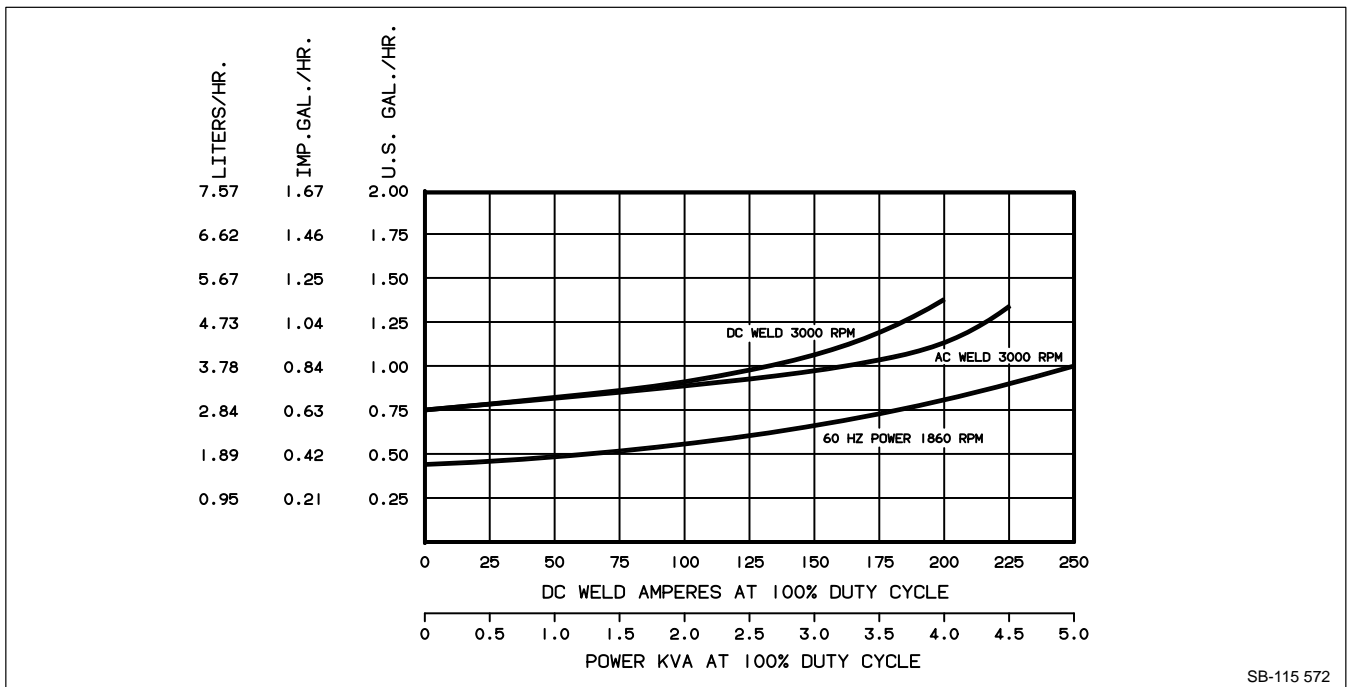

SB-115 572

2-4. Engine Prestart Checks

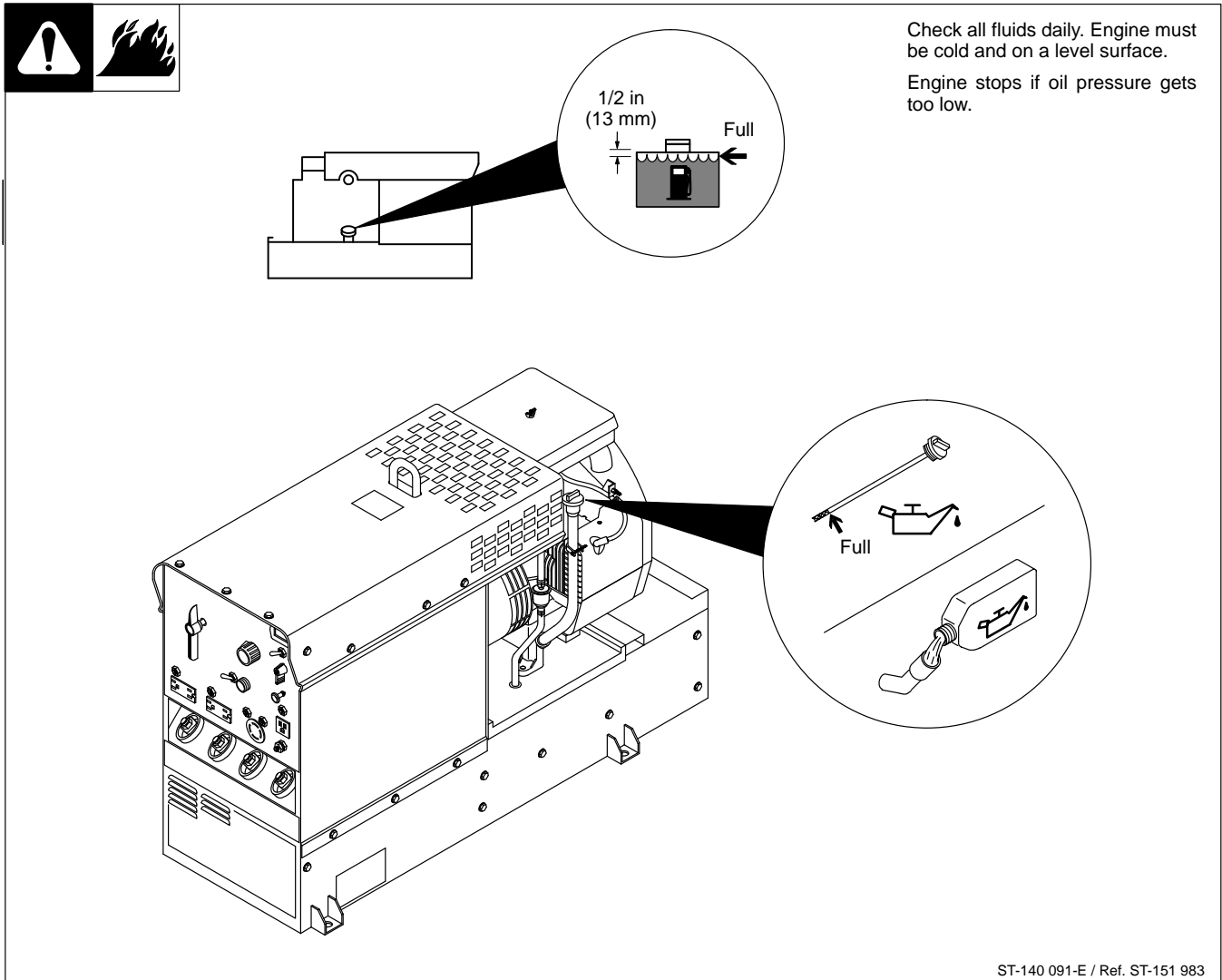

ST-140 091-E / Ref. ST-151 983

2-5. Connecting The Battery

Tools Needed:

3/8, 1/2 in

Ref. ST-144 839-F / Ref. ST-168 046 / Ref. S-0756-D

2-6. Connecting To Weld Output Terminals

▲ Use ONLY one set of terminals at a time. Disconnect weld cables from set of weld output terminals not in use.

Tools Needed:

3/4 in



ST-140 092-B / Ref. ST-168 046

2-7. Selecting Weld Cable Sizes

Welding Amperes	Total Cable (Copper) Length In Weld Circuit Not Exceeding							
	100 ft (30 m) Or Less		150 ft (45 m)	200 ft (60 m)	250 ft (70 m)	300 ft (90 m)	350 ft (105 m)	400 ft (120 m)
	10 – 60% Duty Cycle	60 – 100% Duty Cycle	10 – 100% Duty Cycle					
100	4	4	4	3	2	1	1/0	1/0
150	3	3	2	1	1/0	2/0	3/0	3/0
200	3	2	1	1/0	2/0	3/0	4/0	4/0
250	2	1	1/0	2/0	3/0	4/0	2-2/0	2-2/0
300	1	1/0	2/0	3/0	4/0	2-2/0	2-3/0	2-3/0
350	1/0	2/0	3/0	4/0	2-2/0	2-3/0	2-3/0	2-4/0

Weld cable size (AWG) is based on either a 4 volts or less drop or a current density of at least 300 circular mils per ampere. S-0007-D

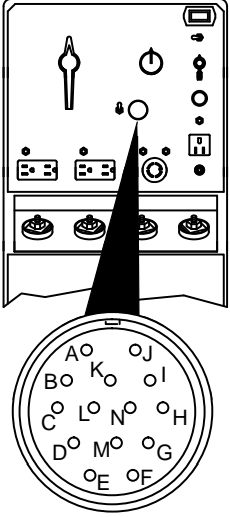
2-8. Remote 14 Receptacle RC1 Information

 ST-140 092-B	REMOTE 14	Socket*	Socket Information
	A		A
B			15 volts dc.
C			+4.5 volts dc output to remote control.
D			Remote control circuit common.
E			0 to +4.5 volts dc input command signal from remote control.
K			Chassis common.

*The remaining sockets are not used.

SECTION 3 – OPERATING WELDING GENERATOR

3-1. Front Panel Controls

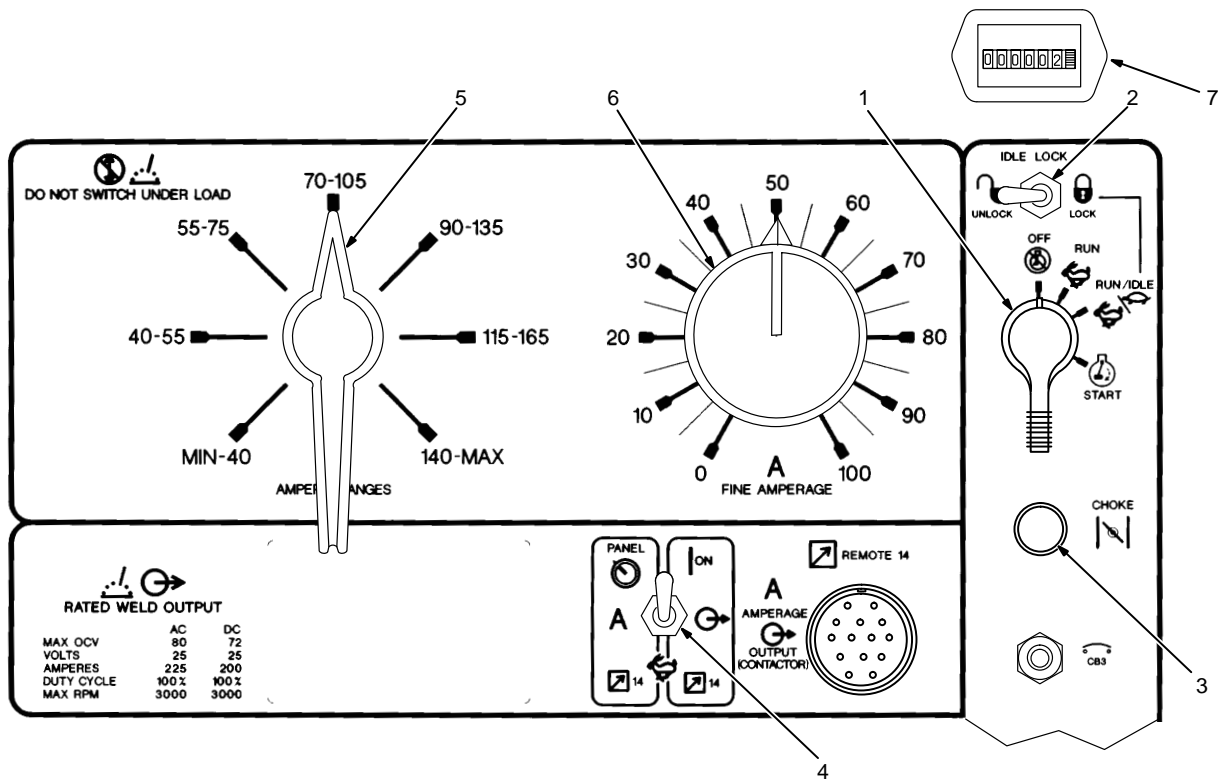

Using Idle Lock Switch		
		 1860 rpm (Power/Idle)
		No Load: 1860 rpm (Power/Idle) Load: 3000 rpm (Weld)
		3000 rpm (Weld)

Ref. ST-168 046

1 Engine Control Switch S2

Use switch to start engine, select speed, and stop engine. In Run/Idle position, engine runs at power/idle rpm at no load, and weld/power rpm under weld or 100 Hz auxiliary power receptacle load. In Run position, engine runs at weld rpm.

2 Idle Lock Switch S1

Use switch to lock engine at power/idle speed (see Table). In Unlock position, Engine Control switch and optional Remote Control switch determine engine speed.

3 Engine Choke Control

Use control to change engine air-fuel mix.

To Start: pull out choke and turn Engine Control switch to Start position. Release switch and slowly push choke in when engine starts. Do not crank engine while fly-wheel is turning.

To Stop: turn Engine Control switch to Off position.

4 Remote Control Switch S4

Use switch to select front panel or remote amperage control (see Section 3-2).

5 Ampere Ranges Switch S5

Use switch to select weld amperage range.

For best arc starts, use lowest amperage range possible.

6 Fine Amperage Control R1

Use control to select weld amperage within the range selected by the Ampere Ranges switch. Control may be adjusted while welding. Scale is for reference only. Weld output would be 88 A DC with control settings as shown (50% of 70 to 105 A).

7 Engine Hour Meter HM

3-2. Remote Control (Optional)

▲ Weld output terminals are energized when Remote Control switch S4 is in Panel/On position and engine is running.

1 Remote 14 Receptacle RC1
Connect optional remote control to RC1 (see Section 2-8).

In Example:
Min = 70 A DC
Percentage Of Range = 50%
Max = 88 A DC (50% of 70 to 105)

Set Switch

Set Range

Set Percentage

Adjust Remote Control

ST-140 092-B

3-3. Duty Cycle

Duty cycle is the percentage of 10 minutes that unit can weld at rated load without overheating.

▲ Exceeding duty cycle can damage unit and void warranty.

100% Duty Cycle at 225 Amperes AC

Continuous Welding

SB-115 570

3-4. Volt-Ampere Curves

The volt-ampere curves show the minimum and maximum voltage and amperage output capabilities of the welding generator. Curves of other settings fall between the curves shown.

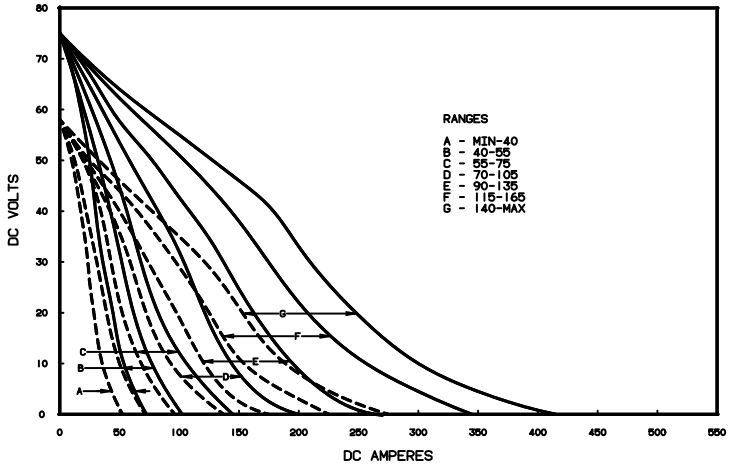
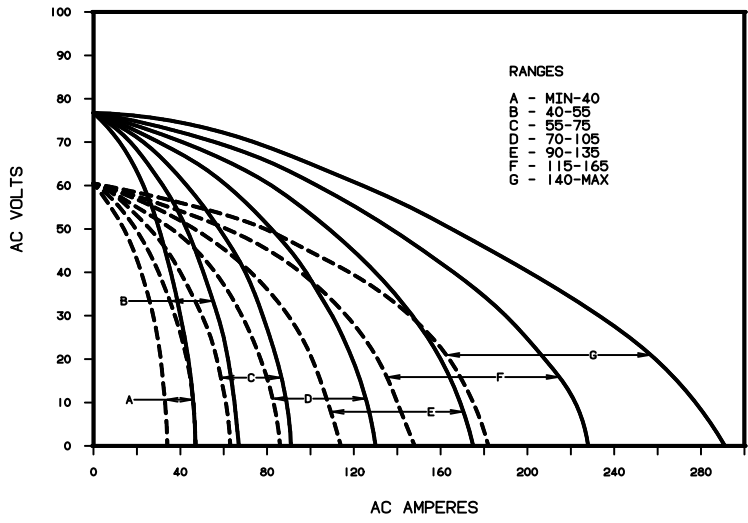

SB-115 529-A / SB-115 528-A

SECTION 4 – OPERATING AUXILIARY EQUIPMENT

4-1. 100 Hz Auxiliary Power Receptacle And Circuit Breaker



▲ Do not operate 50/60 Hz or 60 Hz equipment from 100 Hz receptacle.

1 115 V 9 A 100 Hz AC Receptacle RC4

Receptacle supplies single-phase power at weld speed only. Total output available is 1 kVA/kW.

2 Circuit Breaker CB3

CB3 protects receptacle from overload. If CB3 opens, receptacle does not work.

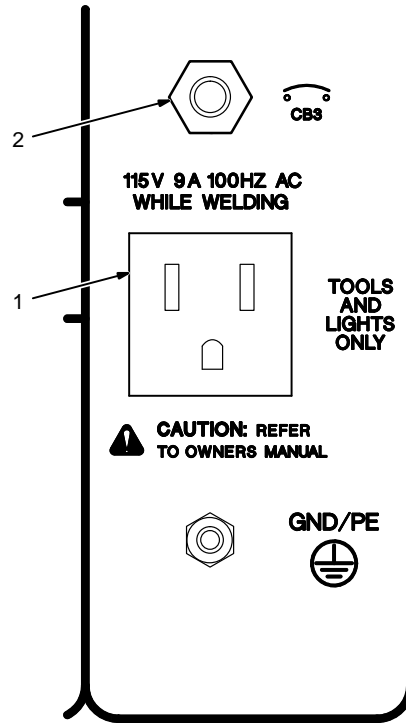

Ref. ST-168 046



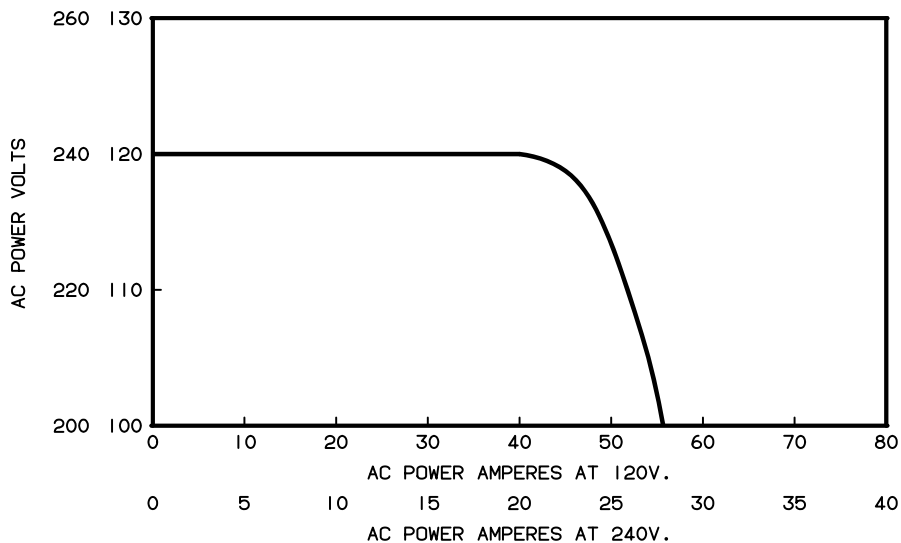



4-2. AC Auxiliary Power Curve



SB-115 571

4-3. 60 Hz Auxiliary Power Receptacles And Circuit Breakers

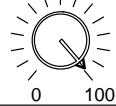

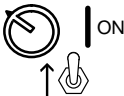
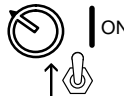
For 60 Hz Auxiliary Power While Welding	For 60 Hz Auxiliary Power Only
 LOCK	 UNLOCK
 RUN/IDLE	 RUN/IDLE
 0 100	 0 100
 PANEL ON	 PANEL ON

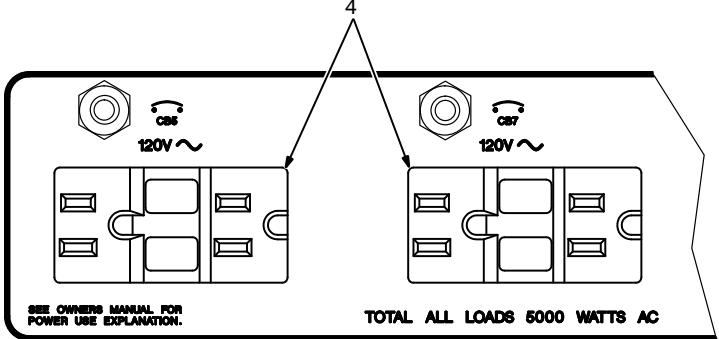

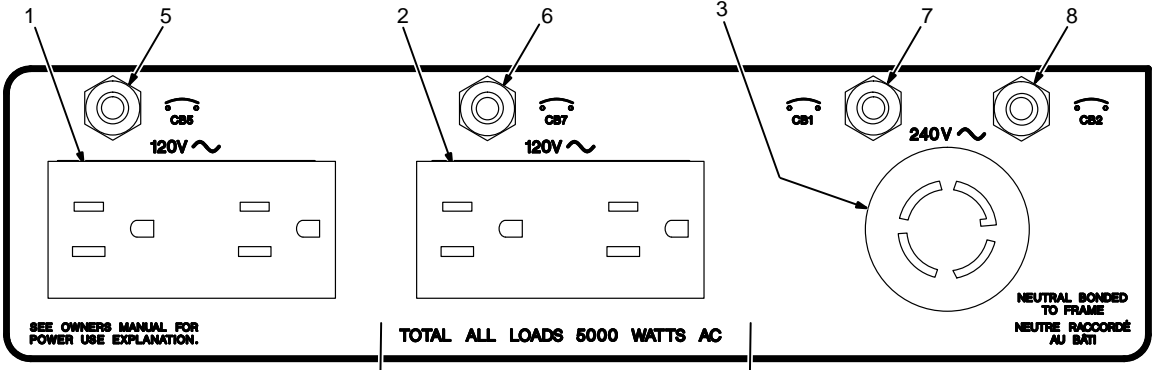

9

Ref. ST-168 046

▲ If unit does not have GFCI receptacles, use GFCI-protected extension cord.

- 1 120 V 15 A AC Duplex Receptacle RC1
- 2 120 V 15 A AC Duplex Receptacle RC2
- 3 240 V 30 A Twistlock Receptacle RC3

Receptacles supply 60 Hz single-phase power at power/idle speed only. Maximum output from each duplex receptacle is 2.5 kVA/kW. Maximum output from twistlock receptacle is 5 kVA/kW. For 60 Hz auxiliary power, set controls as shown in table.

- 4 120 V 15 A AC Duplex GFCI Receptacles GFCI1 And GFCI2 (Optional)

If a ground fault is detected, the GFCI receptacle Reset button pops out and the circuit opens to disconnect the faulty equipment. Check for damaged tools, cords, plugs, etc. connected to the receptacle. Press button to reset receptacle and resume operation.

At least once a month, run engine at power/idle speed and press Test button to verify GFCI is working properly.

- 5 Circuit Breaker CB5
- 6 Circuit Breaker CB7

CB5 protects RC1 and CB7 protects RC2 from overload. If CB5 or CB7 opens, the receptacle does not work. Press button to reset breaker.

- 7 Circuit Breaker CB1
- 8 Circuit Breaker CB2

CB1 and CB2 protect all the 60 Hz receptacles from overload. If CB1 or CB2 opens, the 240 volt receptacle and one of the 120 volts may still be present at the 240 volt receptacle. Press button to reset breaker.

- 9 Total Auxiliary Power Output

Combined output of receptacles limited to the 5 kVA/kW output of the generator:

EXAMPLE: If 10 A is drawn from a 120 V duplex receptacle, only 16 A is available at the 240 V receptacle:

$$(120\text{ V} \times 10\text{ A}) + (240\text{ V} \times 16\text{ A}) = 5.0\text{ kVA/kW}$$

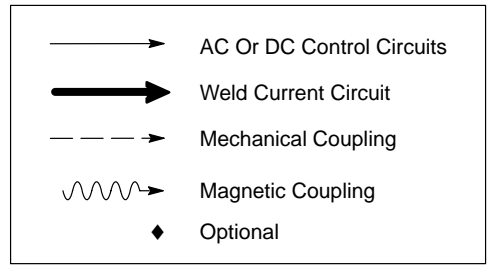
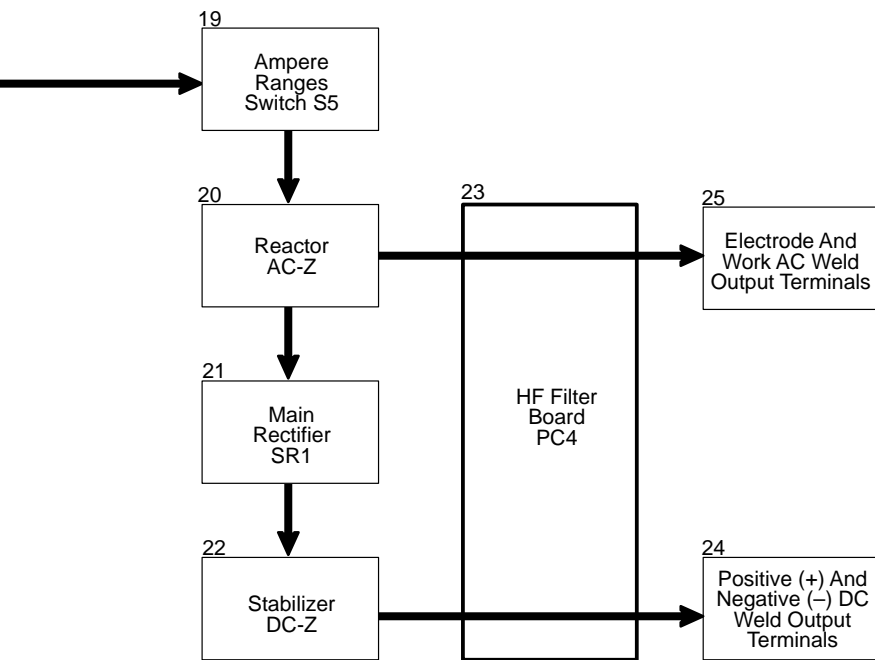
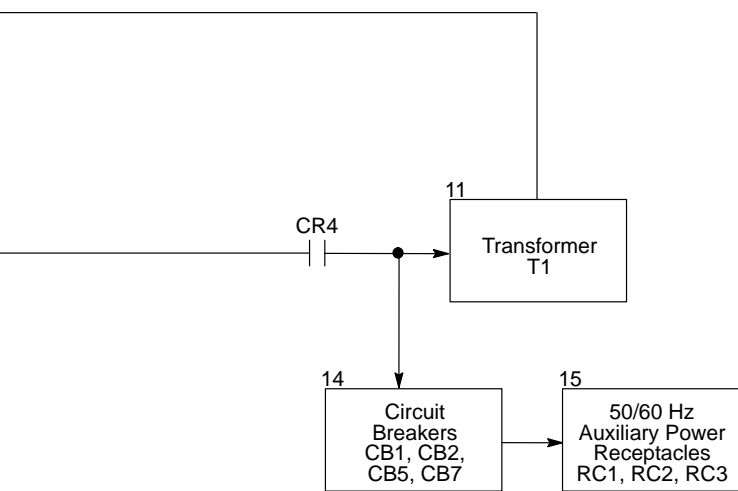

- 13 Remote Control Switch S4
Selects Panel or remote amperage control.
- 14 Circuit Breakers CB1, CB2, CB5, And CB7
Protect 50/60 Hz auxiliary power receptacles RC1, RC2, and RC3 from overload.
- 15 50/60 Hz Auxiliary Power Receptacles RC1, RC2, And RC3
Provide connection points and power for auxiliary equipment.
- 16 Circuit Breaker CB3
Protects 100 Hz auxiliary power receptacle RC4 from overload.
- 17 100 Hz Auxiliary Power Receptacle RC4
Provides connection point and power for auxiliary equipment while welding.
- 18 Fine Amperage Control R1
Adjusts amperage within range selected by Ampere Ranges switch S5.
- 19 Ampere Ranges Switch S5
Selects coarse range of weld output from weld stator.
- 20 Reactor AC-Z
Tapped reactor limits weld output and provides coarse ranges.
- 21 Main Rectifier SR1
Changes ac output from weld windings to dc.
- 22 Stabilizer DC-Z
Smooths out current to dc weld output terminals.
- 23 HF Filter Board PC4
Protects unit from high frequency.
- 24 Positive (+) And Negative (-) DC Weld Output Terminals
Provide dc weld output.
- 25 Electrode And Work AC Weld Output Terminals
Provide ac weld output.

NOTES

SECTION 6 – TROUBLESHOOTING

6-1. Troubleshooting Tables

A. Welding

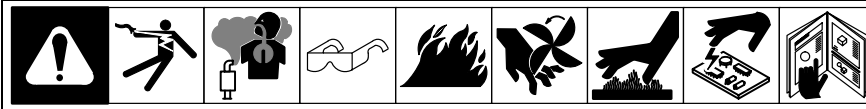

☞ See Sections 6-2 and 6-3 for test points and values and Section 10 for parts location.

Trouble	Remedy
No weld output.	Check fuse F1, and replace if necessary (see Section 8-6).
	Check integrated rectifier SR2, and replace if necessary.
	Check diode D4, and replace if necessary.
	Clean slip rings, and install new brushes if necessary (see Section 6-15).
	Disconnect leads 21, 23, and 33 from brushes, and check continuity across slip rings. Replace rotor if necessary.
	Check resistance and connections of resistors R2 and R4; R2 and R4 are each 12 ohms $\pm 10\%$. Replace resistor(s) if necessary. Adjust R2 and R4 according to Section 6-16.
	Check resistance and connections of Fine Amperage Control R1; R1 is 0 to 30 ohms $\pm 10\%$. Replace R1 if necessary (see Section 3-1).
	Disconnect leads 22 and 29 from SCR/integrated rectifier SR2, and check for continuity between leads 22 and 29. Replace exciter stator if necessary.
	For units with optional remote control, check capacitor C5 for a short or open, and check for proper connections. Replace C5 if necessary.
	Check voltage regulator board PC2 and connections, and replace if necessary (see Section 6-9).
No or erratic weld output.	Clean and tighten weld connections both inside and outside unit.
	Check engine speed, and adjust if necessary (see Section 8-5).
	Check to make sure Ampere Ranges switch S5 is not between positions. Check continuity of S5, and replace if necessary.
	Check reactor AC-Z for signs of winding failure. Check continuity across windings, and check for proper connections. Replace AC-Z if necessary.
	Check resistance and connections of Fine Amperage control R1; R1 is 0 to 30 ohms $\pm 10\%$. Replace R1 if necessary.
	Disconnect leads 21, 23, and 33 from brushes, and check continuity across slip rings. Replace rotor if necessary.
No or erratic DC weld output only.	Check modular main rectifier SR1, and replace if necessary.
	Check stabilizer DC-Z for signs of winding failure. Check continuity across windings, and check for proper connections. Replace DC-Z if necessary.
Low or high weld output.	Check engine speed, and adjust if necessary (see Section 8-5).
	Adjust resistor R4 slider until 128 to 132 volts ac is obtained at 100 Hz receptacle RC4 (see Section 6-16).
	Adjust resistor R2 slider until proper open-circuit-voltage is obtained at weld output terminals (see Section 6-16).
	Check resistance and connections of resistor R3 on suppressor R3, VR1 module; R3 is 1000 ohms $\pm 10\%$. Replace R3, VR1 module if necessary.
	Check reactor AC-Z for signs of winding failure. Check continuity across windings, and check for proper connections. Replace AC-Z if necessary.

B. 50 Or 60 Hz Auxiliary Power

Trouble	Remedy
No auxiliary power output at receptacles RC1, RC2, or RC3.	Run engine at power/idle speed.
	Reset circuit breakers CB1 and CB2. Effective with Serial No. KE629034, also reset circuit breakers CB5 and CB7 (see Section 4-3).
	Check receptacles RC1, RC2, RC3 for continuity and proper connections. Replace receptacle(s) if necessary.
	Check connections to terminal strip 1T.
	Clean slip rings, and install new brushes if necessary (see Section 6-15).
	Check coil voltage and connections of control relay CR4. Check continuity of coil and condition of contacts. Replace CR4 if necessary.
	Check diode D4, and replace if necessary.
	Check idle board/module PC1 and connections (see Section 6-5).
	Check control transformer T1 for signs of winding failure. Check continuity across windings, and check for proper connections. Check primary and secondary voltages. Replace T1 if necessary.
	Disconnect leads 21, 23, and 33 from brushes, and check continuity across slip rings. Replace rotor if necessary.
	Disconnect leads 48 and 49 from voltage regulator board PC2, and check continuity between leads 48 and 49. Disconnect leads 50, 51, 52, and 53 from stator. Check continuity between leads 50 and 51, and 52 and 53. Replace stator if necessary.
Low auxiliary power output.	Check connections to terminal strip 1T.
	Clean slip rings, and install new brushes if necessary (see Section 6-15).
	Check integrated rectifier SR2, and replace if necessary.
	Check coil voltage and connections of control relay CR3. Check continuity of coil and condition of contacts. Replace CR3 if necessary.
	Check voltage regulator board PC2 and connections, and replace if necessary.
High auxiliary power output.	Check engine speed, and adjust if necessary.
	Check voltage regulator board PC2 and connections, and replace if necessary (see Section 6-9).

C. 100 Hz Auxiliary Power

Trouble	Remedy
No auxiliary power output at receptacle RC4.	Run engine at weld speed.
	Reset circuit breaker CB3 (see Section 4-1).
	Check receptacle RC4 for continuity and proper connections. Replace receptacle if necessary.
	Disconnect leads 90, 91, 92, and 93 from stator. Check continuity between leads 90 and 91, and 92 and 93. Replace stator if necessary.
	Check diode D4, and replace if necessary.

D. Engine

Trouble	Remedy
Engine will not start.	Check fuel level (see Section 2-4).
	Check battery and engine charging system according to engine manual.
	Check continuity of Engine Control switch S2, and replace if necessary.
	See engine manual.
Engine starts but stops as soon as Engine Control switch S2 returns to Run position.	Check oil level (see Section 2-4). Check low oil pressure shutdown switch S3 (see engine parts manual for location). S3 should close when engine is running.
	Check and refill crankcase with proper viscosity oil for operating temperature, if necessary (see engine manual).
	Check continuity of Engine Control switch S2, and replace if necessary.
Engine stopped during normal operation.	Check oil level (see Section 2-4). Check low oil pressure shutdown switch S3 (see engine parts manual for location). S3 should close when engine is running.
	Check continuity of Engine Control switch S2, and replace if necessary.
Battery discharges between uses.	Make sure Engine Control switch S2 is placed in the Off position when engine is not in use (see Section 3-1).
	Prior to Serial No. KA780044, check fuse F2 and replace if necessary.
	Clean battery, terminals and posts with baking soda solution; rinse with clear water.
	Periodically recharge battery (approximately every 3 months).
	Check voltage regulator according to engine manual.
	Replace battery.
Engine idles, but does not come up to weld speed.	Wait 10 seconds for throttle solenoid circuit breaker CB4 to reset (see Section 8-6).
	Place Idle Lock switch S1 in Unlock position (see Section 3-1).
	Check continuity and connections of current transformer CT1, and replace if necessary.
	Check continuity of Engine Control switch S2, and replace if necessary.
	Check coil voltage and connections of control relay CR2. Check continuity of coil and condition of contacts. Replace CR2 if necessary.
	Check diode D6 in throttle solenoid TS1 circuit, and replace if necessary.
	Check resistance at throttle solenoid TS1 terminals. With plunger out, resistance is less than 1 ohm. With plunger bottomed, resistance is 17 ohms \pm 10%.
	Check throttle linkage for smooth, non-binding operation.
	Check idle board/module PC1 and connections, and replace if necessary (see Section 6-5).
Engine does not return to idle speed.	Remove weld load.
	Check continuity of Engine Control switch S2, and replace if necessary.
	Check throttle linkage for smooth, non-binding operation.
Unstable or sluggish engine speeds.	Readjust throttle linkage if necessary.
	Tune-up engine according to engine manual.

6-2. Troubleshooting Circuit Diagram For Welding Generator

Resistance Values

- Tolerance – $\pm 10\%$ unless specified
- Condition – 70°F (21°C); cold machine (no warm-up)
- Wiring Diagram – see Section 9
- Stop engine before checking resistance

R1	29 ohms
R2	34 ohms
R3	35 ohms
R4	2 ohms
R5	2 ohms
R6 thru R17	Less than 1 ohm
R18	Pull: Less than 1 ohm Hold: 16.5 ohms

Test Equipment Needed:

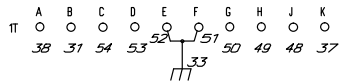
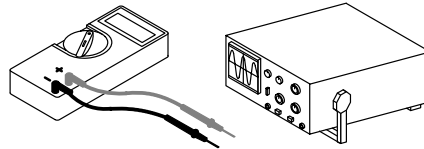

SPRINGS BACK TO IDLE POSITION

S2	OFF	RUN	IDLE	AUX.	START
1		X	X	X	X
2		X	X	X	X
3		X			
4				X	X
5					X

X = CLOSED TO "B" TERMINAL

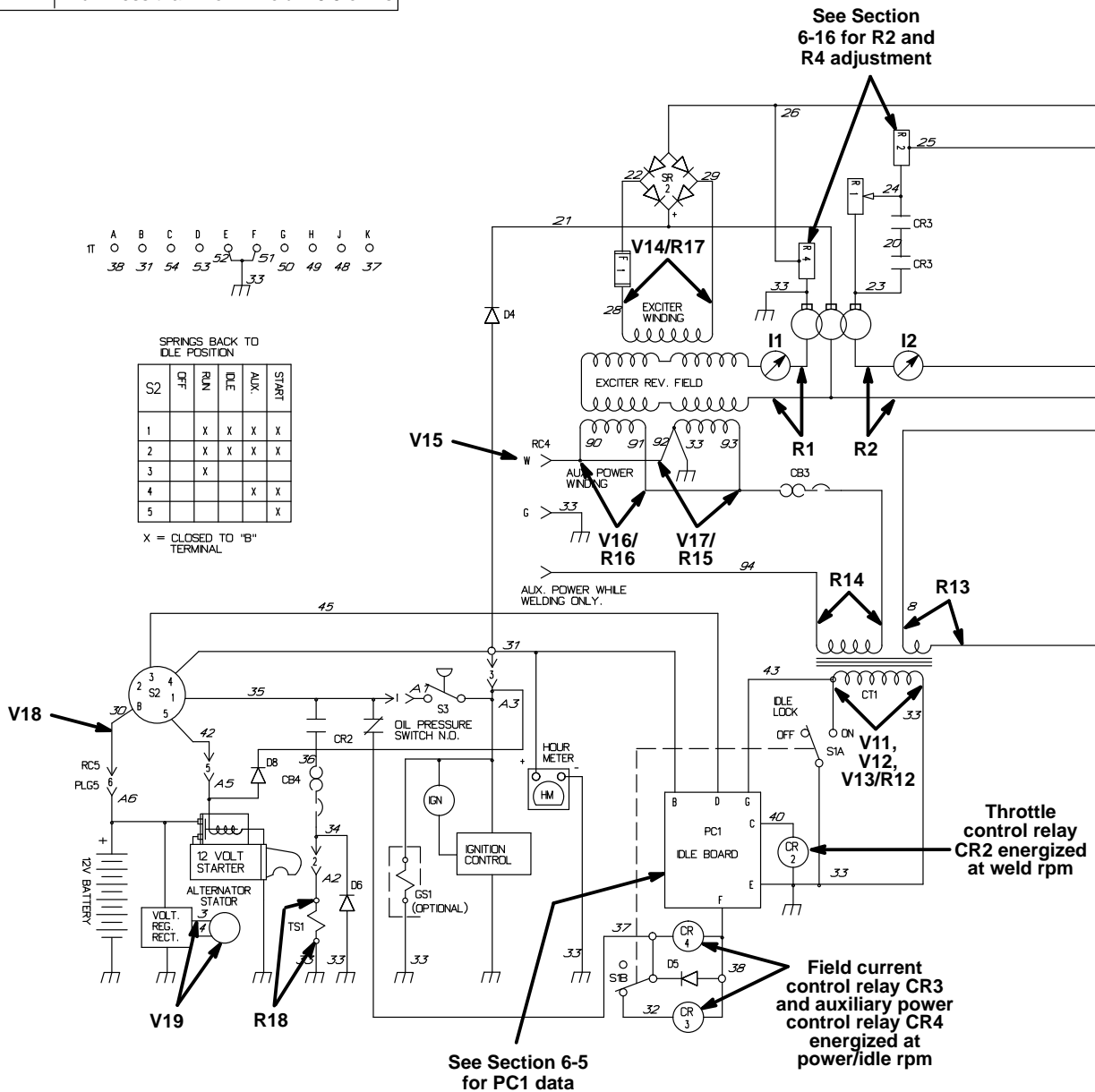

Amperage Readings	
a) Tolerance – $\pm 5\%$ unless specified	
b) Condition – 70°F (21°C); cold machine (no warm-up); no load	
I1	3 amps dc
I2	1.8 amps dc (R1 at min.) 3.1 amps dc (R1 at max.)



Voltage Readings	
a) Tolerance – $\pm 10\%$ unless specified	
b) Condition – 70°F (21°C); cold machine (no warm-up); no load	
c) Reference – to circuit common (lead 33) unless noted	
d) Wiring Diagram – see Section 9	

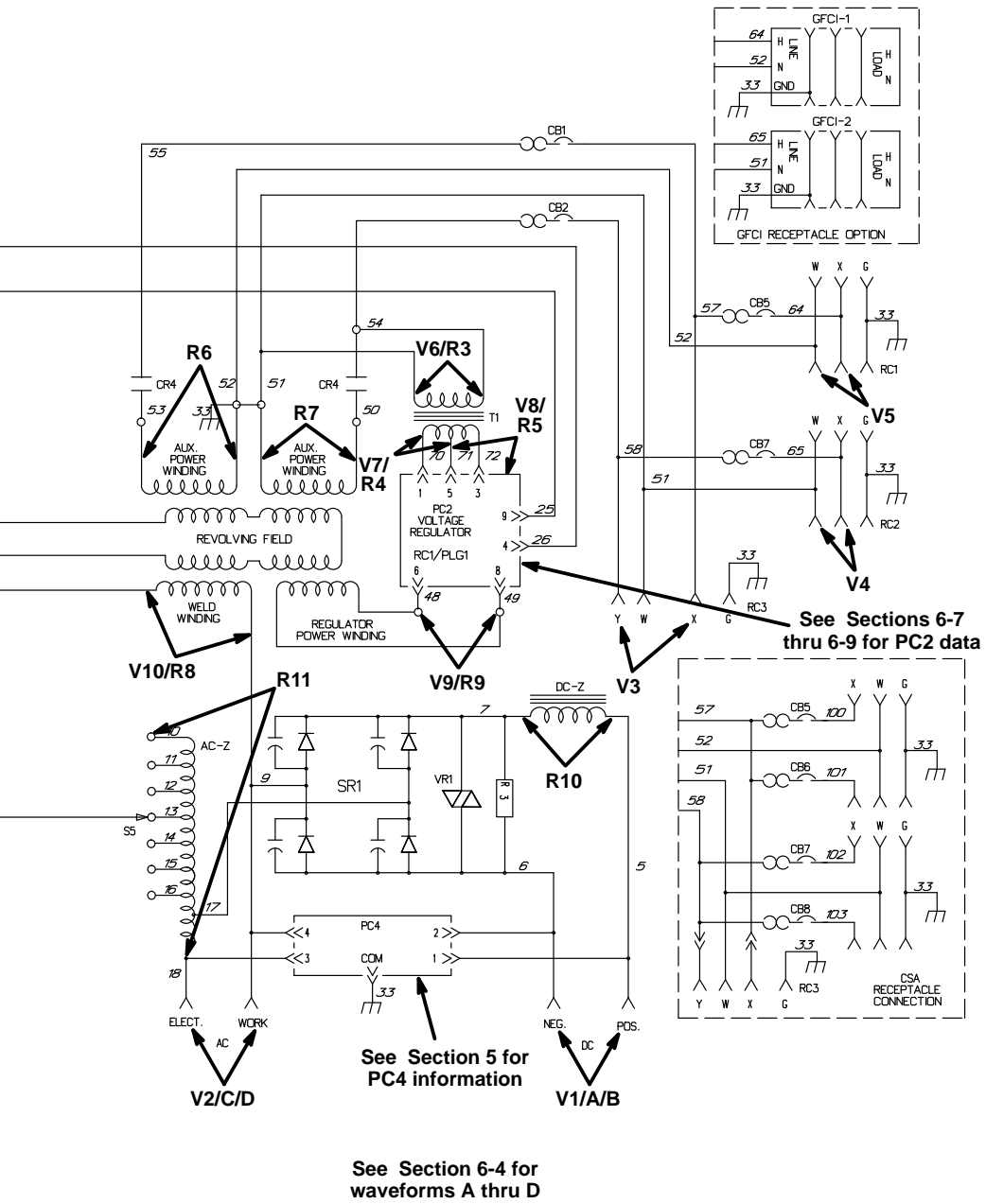

V1	DC/CC OCV at weld rpm: 58 volts dc (R1 at min.) 70 volts dc (R1 at max.) (Do not exceed 72 volts dc)
V2	AC/CC OCV, at weld rpm: 65 volts ac (R1 at min.) 80 volts ac (R1 at max.) (Do not exceed 80 volts ac)
V3	At RC3 at power/idle rpm: 244 volts ac $\pm 5\%$ (50 or 60 Hz)
V4	At RC2 at power/idle rpm: 122 volts ac $\pm 5\%$ (50 or 60 Hz)
V5	At RC1 at power/idle rpm: 122 volts ac $\pm 5\%$ (50 or 60 Hz)
V6	AC input to transformer T1: 122 volts ac (power/idle rpm), 0 volts ac (weld rpm)
V7	AC output to PC2: 21 volts ac $\pm 5\%$
V8	AC output to PC2: 21 volts ac $\pm 5\%$
V9	AC output from Regulator Power Winding (power/idle rpm) 158 volts ac $\pm 5\%$
V10	AC output from Weld Winding at weld rpm: 65 volts ac (R1 at min.), 80 volts ac (R1 at max.) (Do not exceed 80 volts ac)
V11	At rated DC weld load: At least 1 volts ac
V12	At weld rpm and 100 watt light bulb load applied: 3 volts ac or greater
V13	Idle Lock switch S1 in Lock: 0 volts ac at all times
V14	AC output from Exciter Winding 80 volts ac (power/idle rpm) 145 volts ac (weld rpm)
V15	At RC4 at weld speed: at least 120 volts ac (Do not exceed 132 volts ac)
V16	Auxiliary power winding at weld rpm: at least 120 volts ac (Do not exceed 132 volts ac)
V17	Auxiliary power winding at weld rpm: at least 120 volts ac (Do not exceed 132 volts ac)
V18	Battery output whenever engine is running: 14 volts dc.
V19	AC Alternator output: 17 volts ac (power/idle rpm) 39 volts ac (weld rpm)

6-3. Troubleshooting Circuit Diagram For Welding Generator With Optional Remote Control

Resistance Values

- a) Tolerance – ±10% unless specified
- b) Condition – 70°F (21°C); cold machine (no warm-up)
- c) Wiring Diagram – see Section 9
- d) Stop engine before checking resistance

R1	29 ohms
R2	34 ohms
R3	35 ohms
R4	2 ohms
R5	2 ohms
R6 thru R17	Less than 1 ohm

Test Equipment Needed:

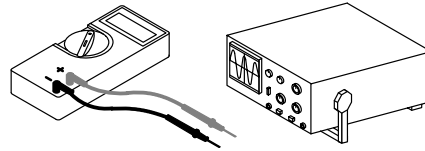

See Section 6-13 for PC5 data

See Section 6-11 for PC3 data

See Section 6-16 for R2 and R4 adjustment

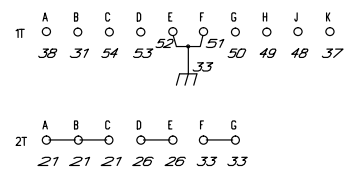

Field flashing disconnect relay CR5

SPRINGS BACK TO IDLE POSITION

S2	OFF	RUN	IDLE	AUX	START
1		X	X	X	X
2		X	X	X	X
3		X			
4				X	X
5					X

X = CLOSED TO "B" TERMINAL

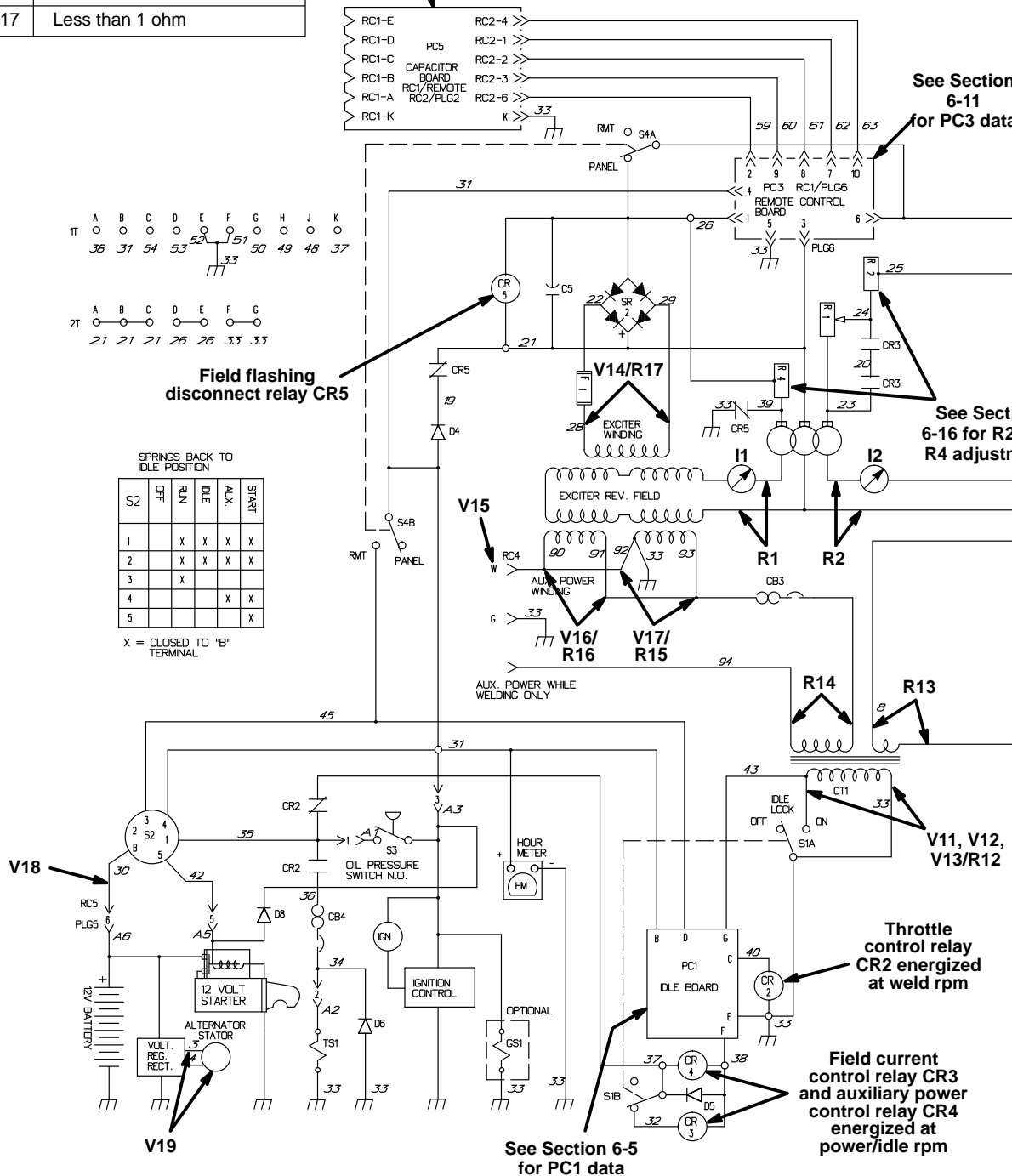

See Section 6-5 for PC1 data

Throttle control relay CR2 energized at weld rpm

Field current control relay CR3 and auxiliary power control relay CR4 energized at power/idle rpm

Amperage Readings	
a) Tolerance – $\pm 5\%$ unless specified	
b) Condition – 70°F (21°C); cold machine (no warm-up); no load	
I1	3 amps dc
I2	1.8 amps dc (R1 at min.) 3.1 amps dc (R1 at max.)



Voltage Readings	
a) Tolerance – $\pm 10\%$ unless specified	
b) Condition – 70°F (21°C); cold machine (no warm-up); no load	
c) Reference – to circuit common (lead 33) unless noted	
d) Wiring Diagram – see Section 9	

V1	DC/CC OCV at weld rpm: 58 volts dc (R1 at min.) 70 volts dc (R1 at max.) (Do not exceed 72 volts dc)
V2	AC/CC OCV, at weld rpm: 65 volts ac (R1 at min.) 80 volts ac (R1 at max.) (Do not exceed 80 volts ac)
V3	At RC3 at power/idle rpm: 244 volts ac $\pm 5\%$ (50 or 60 Hz)
V4	At RC2 at power/idle rpm: 122 volts ac $\pm 5\%$ (50 or 60 Hz)
V5	At RC1 at power/idle rpm: 122 volts ac $\pm 5\%$ (50 or 60 Hz)
V6	AC input to transformer T1: 122 volts ac (power/idle rpm), 0 volts ac (weld rpm)
V7	AC output to PC2: 21 volts ac $\pm 5\%$
V8	AC output to PC2: 21 volts ac $\pm 5\%$
V9	AC output from Regulator Power Winding (power/idle rpm) 158 volts ac $\pm 5\%$
V10	AC output from Weld Winding at weld rpm: 65 volts ac (R1 at min.), 80 volts ac (R1 at max.) (Do not exceed 90 volts ac)
V11	At rated DC weld load: At least 1 volts ac
V12	At weld rpm and 100 watt light bulb load applied: 3 volts ac or greater
V13	Idle Lock switch S1 in Lock: 0 volts ac at all times
V14	AC output from Exciter Winding 80 volts ac (power/idle rpm) 145 volts ac (weld rpm)
V15	At RC4 at weld speed: at least 120 volts ac (Do not exceed 132 volts ac)
V16	Auxiliary power winding at weld rpm: at least 120 volts ac (Do not exceed 132 volts ac)
V17	Auxiliary power winding at weld rpm: at least 120 volts ac (Do not exceed 132 volts ac)
V18	Battery output whenever engine is running: 14 volts dc.
V19	AC Alternator output: 17 volts ac (power/idle rpm) 39 volts ac (weld rpm)

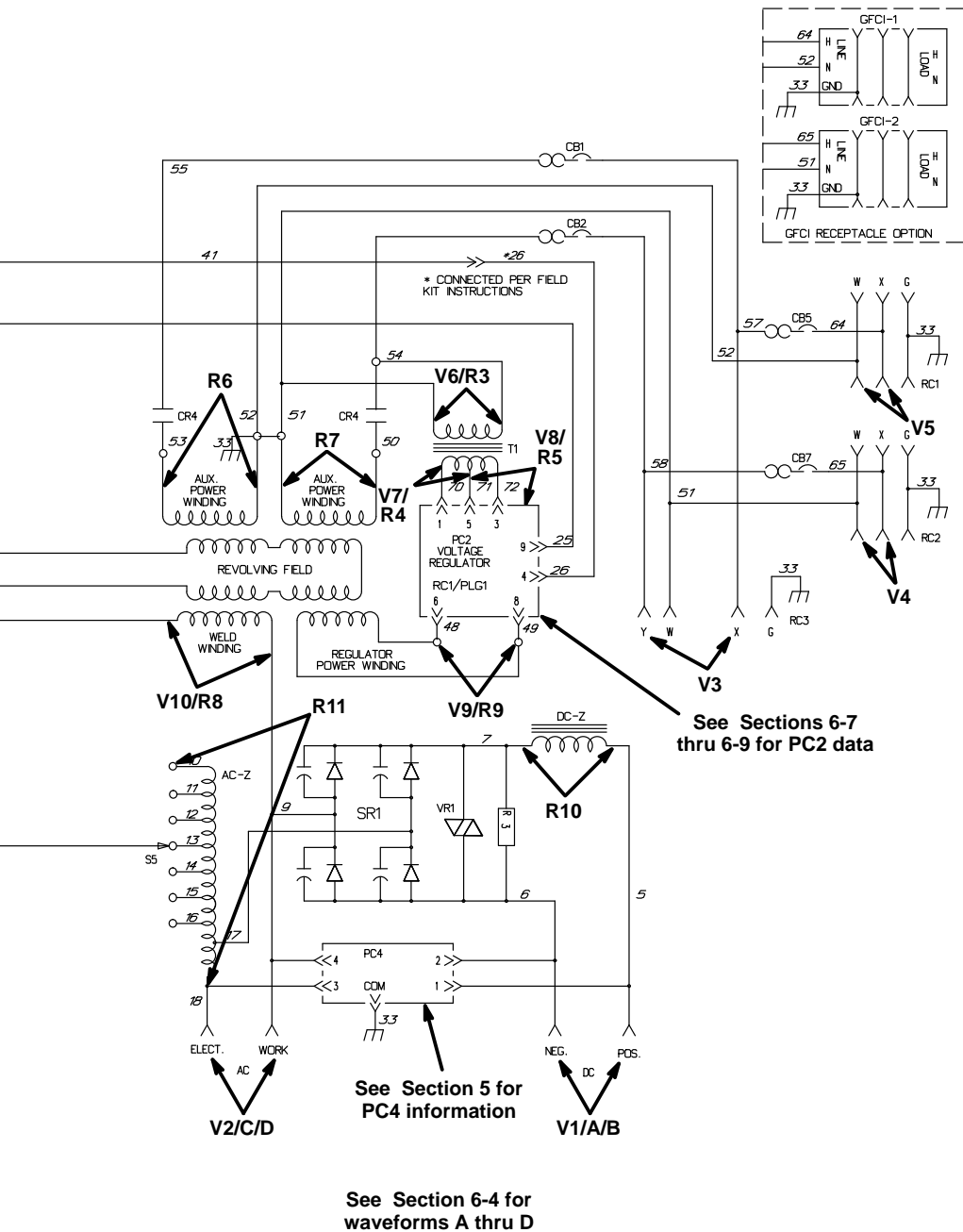

6-4. Waveforms For Sections 6-2 And 6-3

2 ms 50 V

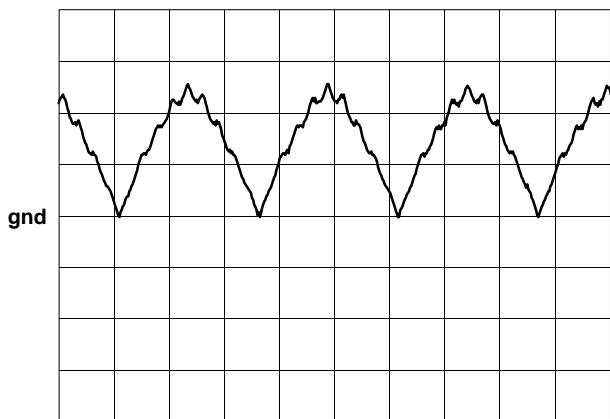

A. DC Open-Circuit Voltage, Ampere Ranges Switch S5 In Max Position

2 ms 10 V

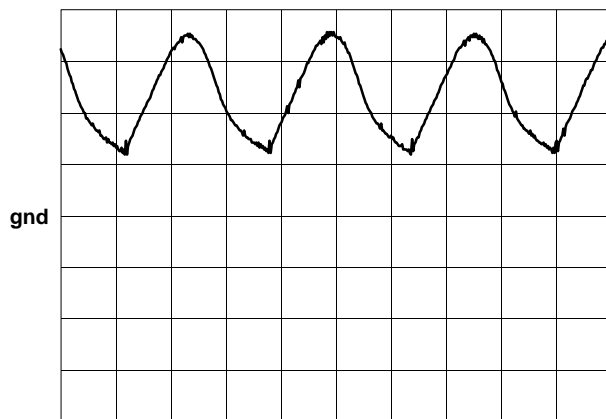

B. DC Weld Output, 25 Volts DC, 100 Amperes, Ampere Range Switch S5 In 70-105 Position (Resistive Load)

5 ms 50 V

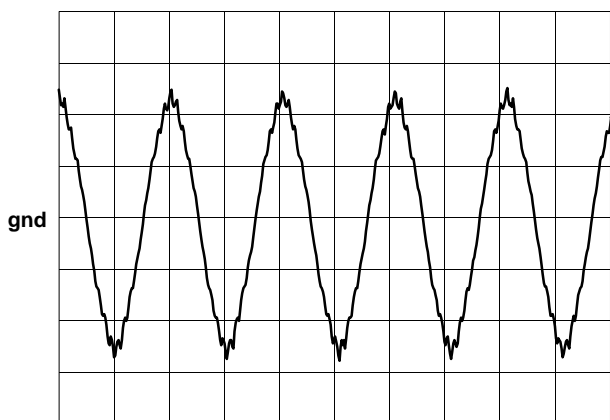

C. AC Open-Circuit Voltage, Ampere Ranges Switch S5 In Max Position

5 ms 20 V

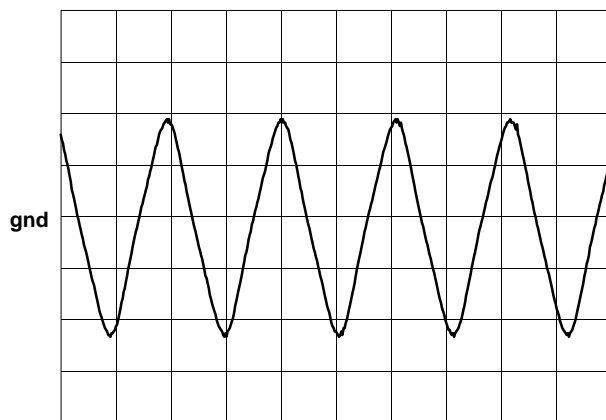

D. AC Weld Output, 25 Volts AC, 100 Amperes, Ampere Range Switch S5 In 70-105 Position (Resistive Load)



Waveforms shown are for 60 Hertz models; waveforms for 50 Hertz models are similar.



Test Equipment Needed:

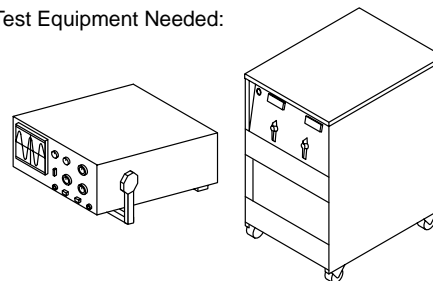

6-5. Idle Control Board/Module PC1 Testing Information

Be sure plugs are secure before testing. See Section 6-6 for specific values during testing.

- 1 Idle Control Board PC1 (Prior To Serial No. JH300534)
- 2 Idle Module PC1 (Effective With Serial No. JH300534)

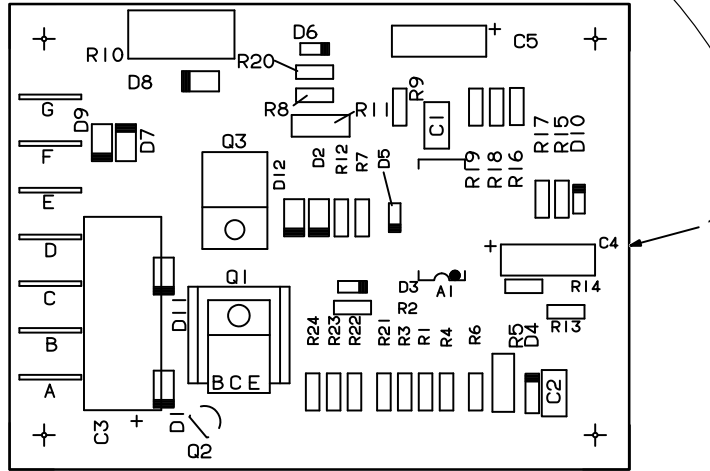

OR

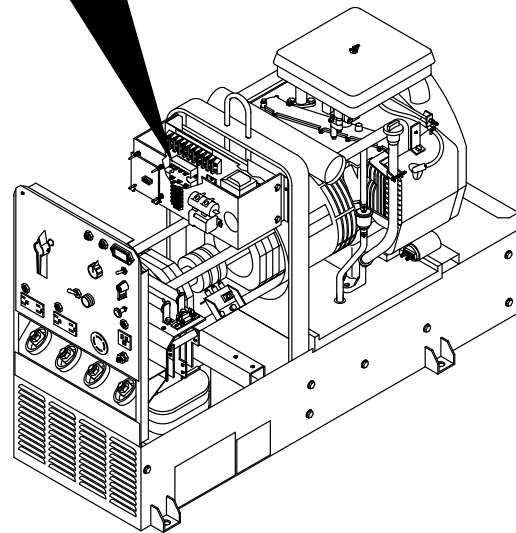
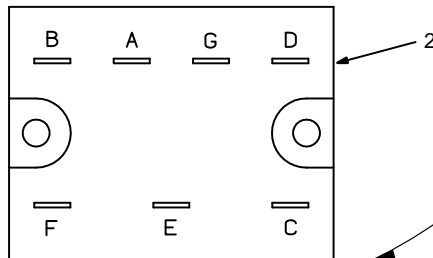

Test Equipment Needed:

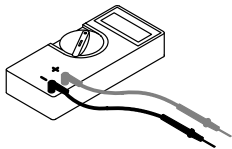

Ref. ST-800 698-A / SC-113 702-A

6-6. Troubleshooting Flowcharts For Idle Control Board/Module PC1

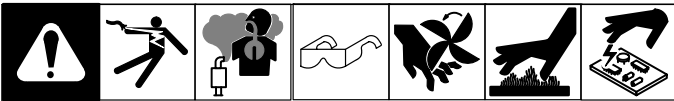

Engine does not go to power/idle rpm with no weld load applied.

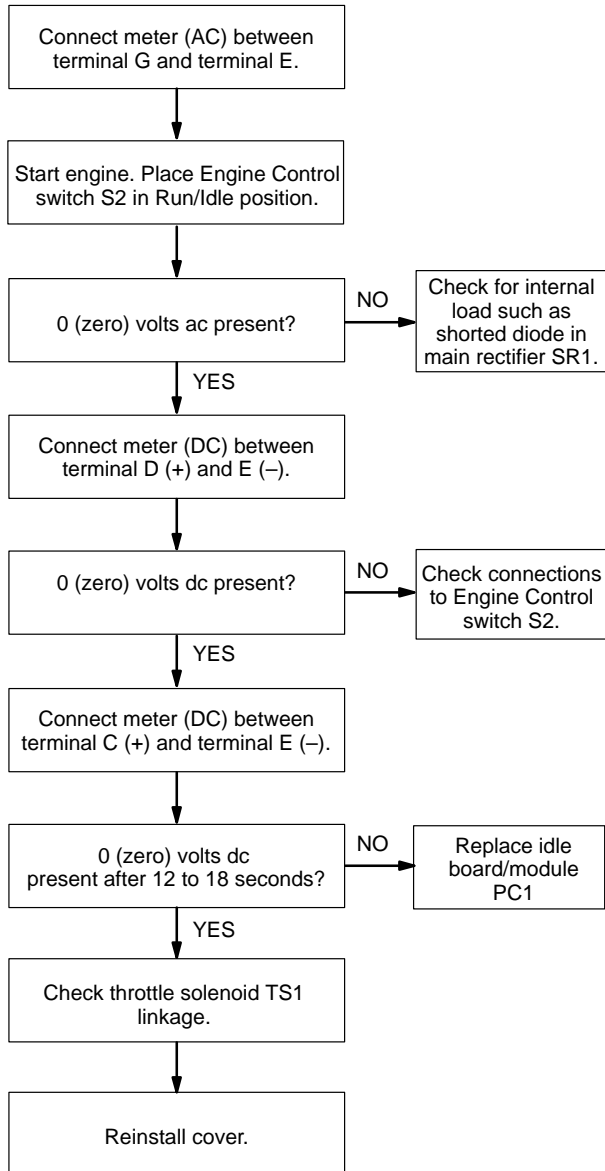

Engine does not go to weld rpm with load applied.

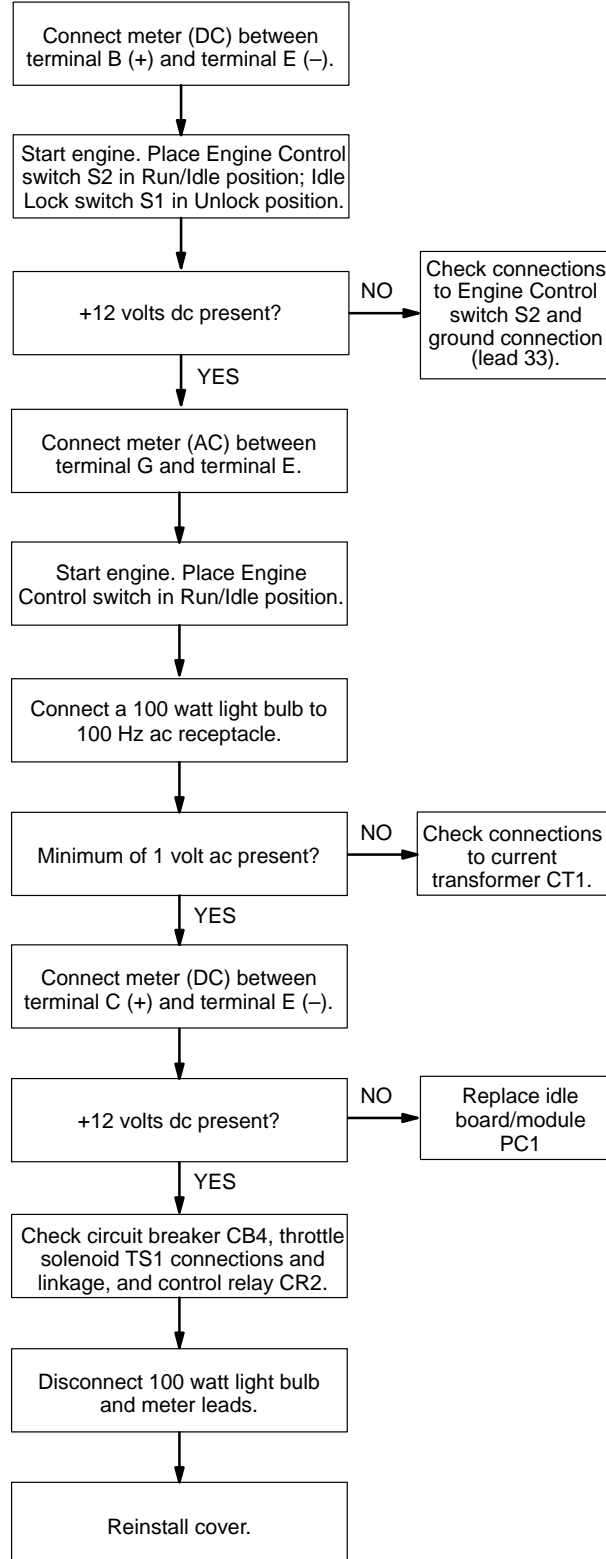

Engine does not go to weld rpm with Engine Control switch S2 in Run position.

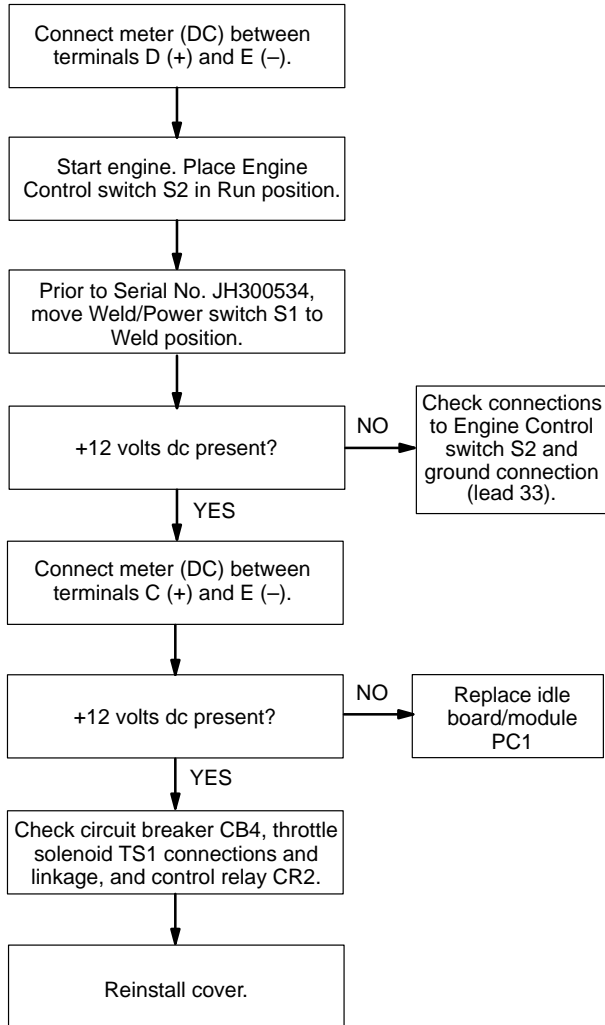

Control Relays CR3 and CR4 do not energize at idle rpm (See Section 5 for CR3 and CR4 information)

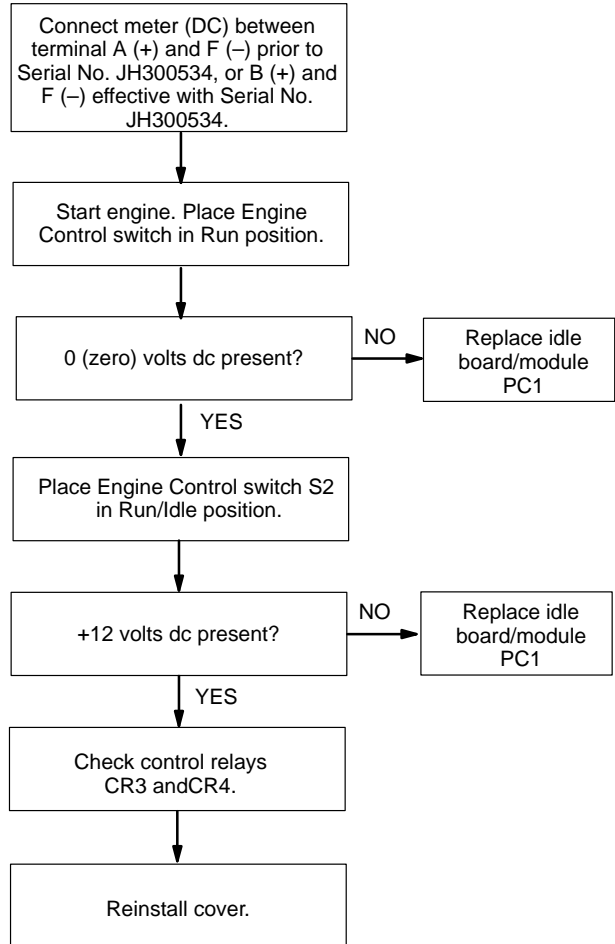

6-7. Voltage Regulator Board PC2 Testing Information Prior To Serial No. KE604176

Be sure plugs are secure before testing. See Section 6-8 for specific values during testing.

- 1 Voltage Regulator Board PC2
- 2 Terminals A Thru G

Test Equipment Needed:

Ref. ST-800 698-A / SA-099 497-B

6-8. Voltage Regulator Board PC2 Test Point Values Prior To Serial No. KE604176

PC2 Voltage Readings

- a) Tolerance – $\pm 10\%$ unless specified
- b) Reference – to circuit common (lead 33) unless noted

Receptacle	Value
A	Circuit common
B	18 volts ac input with respect to pin A
C	18 volts ac input with respect to pin A
D	Circuit common
E	130 volts ac input with respect to terminal G at power/idle rpm
F	55 volts dc output with respect to terminal D at power/idle rpm
G	130 volts ac input with respect to terminal E at power/idle rpm

6-9. Voltage Regulator Board PC2 Testing Information Effective With Serial No. KE604176

1 Voltage Regulator Board PC2
2 Receptacle RC1

Be sure plugs are secure before testing. See Section 6-10 for specific values during testing.

Test Equipment Needed:

Ref. ST-800 698-A / SA-160 889-A

6-10. Voltage Regulator Board PC2 Test Point Values Effective With Serial No. KE604176

			PC2 Voltage Readings	<p>a) Tolerance – $\pm 10\%$ unless specified</p> <p>b) Reference – to circuit common (lead 33) unless noted</p>
Receptacle	Pin	Value		
RC1	1	18 volts ac input with respect to pin 5		
	2	Not used		
	3	18 volts ac input with respect to pin 5		
	4	Circuit common		
	5	Circuit common		
	6	130 volts ac input with respect to pin 8 at power/idle rpm		
	7	Not used		
	8	130 volts ac input with respect to pin 6 at power/idle rpm		
	9	55 volts dc output with respect to pin 4 at power/idle rpm		

6-11. Optional Remote Control Board PC3 Testing Information

1 Remote Control Board PC3
2 Receptacle RC1

Test Equipment Needed:

Be sure plugs are secure before testing. See Section 6-12 for specific values during testing.

Ref. ST-800 698-A / ST-115 941-L / SA-138 247

6-12. Optional Remote Control Board PC3 Test Point Values

Receptacle	Pin*	Value
RC1	1 (A)	Circuit common
	2 (B)	Circuit common
	3 (C)	+50 volts dc input at power/idle rpm; 100 volts dc input at weld rpm
	4 (D)	+12 volts dc input with respect to pin 5 at power/idle or weld rpm
	5 (E)	Chassis ground (lead 33)
	6 (F)	59 to 6.8 volts dc output with respect to pin 1 from min to max of remote control with remote contactor control switch closed, 130 volts dc output with remote contactor control switch open
	7 (G)	Circuit common
	8 (H)	Command reference output, +4.5 volts dc output with respect to pin 7
	9 (J)	0 volts dc output with remote contactor control switch closed, +15 volts dc output with remote contactor control switch open
	10 (K)	0 to +4.5 volts dc input from min to max of Fine Amperage control R1 at power/idle rpm

*Letter(s) in parenthesis () is pin letter prior to Serial No. KA840710.

6-13. Optional Remote Capacitor Board PC5 Testing Information Effective With Serial No. KD346698

Be sure plugs are secure before testing. See Section 6-14 for specific values during testing.

- 1 Capacitor Board PC5
- 2 Remote 14 Receptacle RC1
- 3 Receptacle RC2
- 4 Terminal K

Test Equipment Needed:

Ref. ST-800 698-A / SA-156 026-C

6-14. Optional Remote Capacitor Board PC5 Test Point Values Effective With Serial No. KD346698

PC5 Voltage Readings

a) Tolerance – $\pm 10\%$ unless specified

b) Reference – to circuit common (lead 33) unless noted

Receptacle	Pin	Value
RC1	A	Contact closure to pin B completes the dc contactor control circuit
	B	+15 volts dc output
	C	Command reference, +4.5 volts dc output
	D	Remote control circuit command
	E	Input command signal from potentiometer wiper, 0 to +4.5 volts dc input
	K	Chassis ground (lead 33)
RC2	1	Remote control circuit common
	2	Command reference, +4.5 volts dc input
	3	+15 volts dc input
	4	Command signal from potentiometer wiper, 0 to +4.5 volts dc output
	5	Not used
	6	Contact closure to pin 3 completes contactor control circuit
Terminal	K	Chassis ground (lead 33)

6-15. Replacing Brushes And Cleaning Slip Rings

A. Checking Brushes And Cleaning Slip Rings

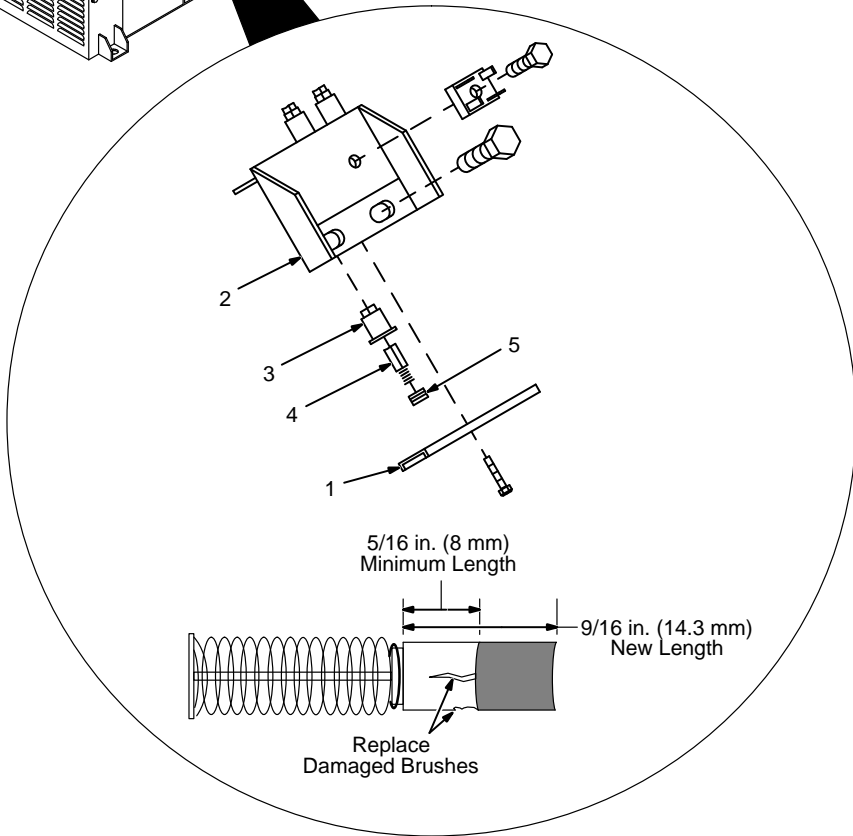
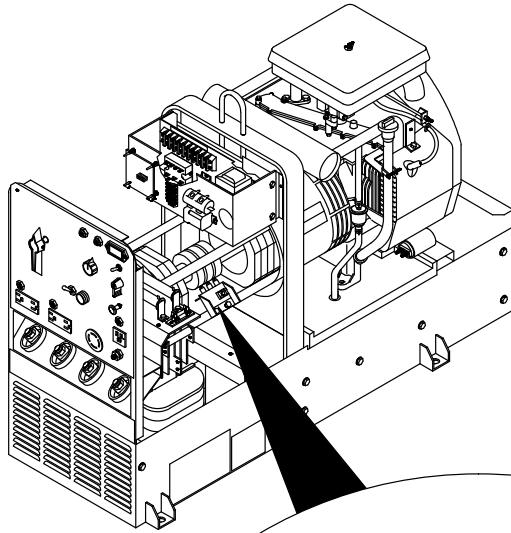
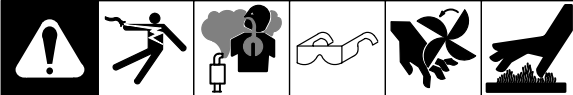

Tools Needed:

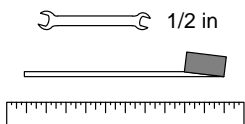

Stop engine and allow to cool.

- 1 Brush Holder Retaining Bar
- 2 Brush Holder Bracket

Remove brush holder bracket. Keep hardware for reinstallation.

- 3 Brush Holder
- 4 Brush With Spring
- 5 Brush Holder Cap

Mark and disconnect leads at caps, and remove brushes from bracket.

Replace brushes if damaged, or if brush is at or near minimum length.

- 6 Slip Rings

Inspect slip rings. Under normal use, rings turn dark brown.

If slip rings are corroded or surface is uneven, insulate brush leads, start engine, and clean rings with a commutator stone. Remove as little material as possible. Stop engine.

Install brushes, bracket, and remaining generator parts. Adjust brushes as shown in Section B.

Reinstall both side panels and top cover.

B. Adjusting Brush Position

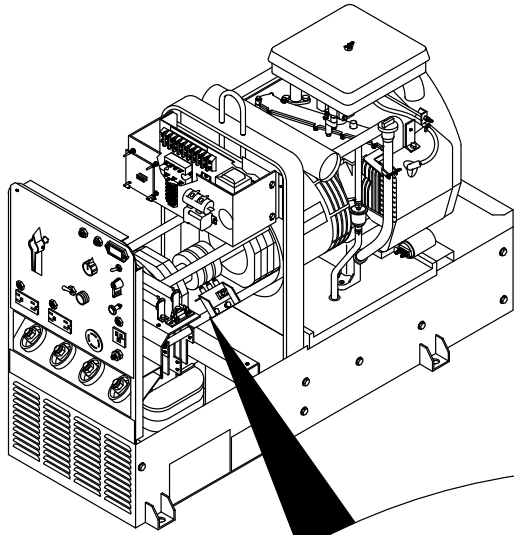
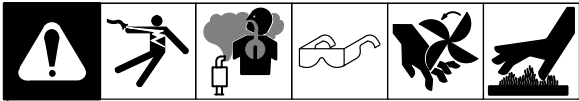

Stop engine.

After installing brushes, adjust brush position as follows:

- 1 Brush Holder
- 2 Brass Sleeve
- 3 Brush
- 4 Slip Ring

Loosen brush holder bracket mounting hardware. Move bracket until brass sleeves are positioned as shown. Tighten hardware.

Reinstall side panels and cover.

If operation is still not okay, have a qualified machine shop turn and polish slip rings.

Side View

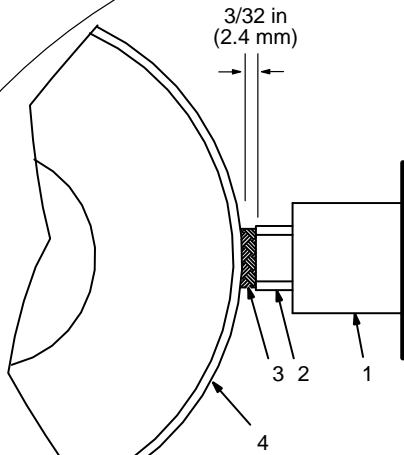

Correct Brush Position

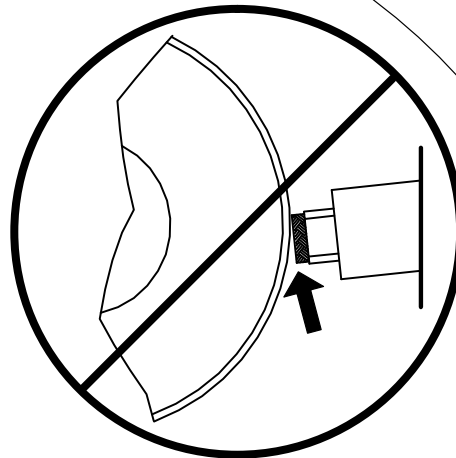

Incorrect Brush Position

Top View

Center brushes on slip rings.

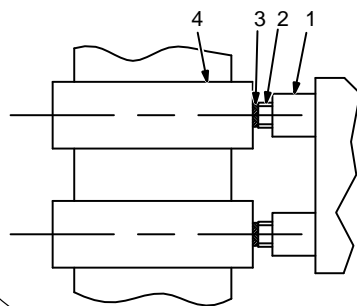

Correct Brush Position

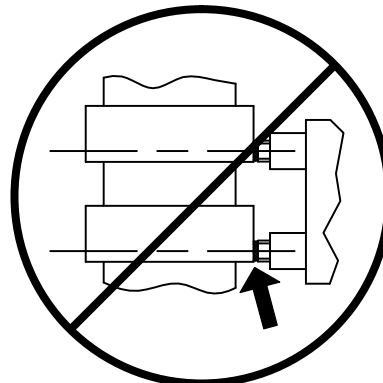

Incorrect Brush Position

Tools Needed:

3/8, 1/2 in

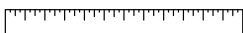

Ref. ST-800 698-A / Ref. ST-800 677-B

6-16. Checking Unit Output After Servicing

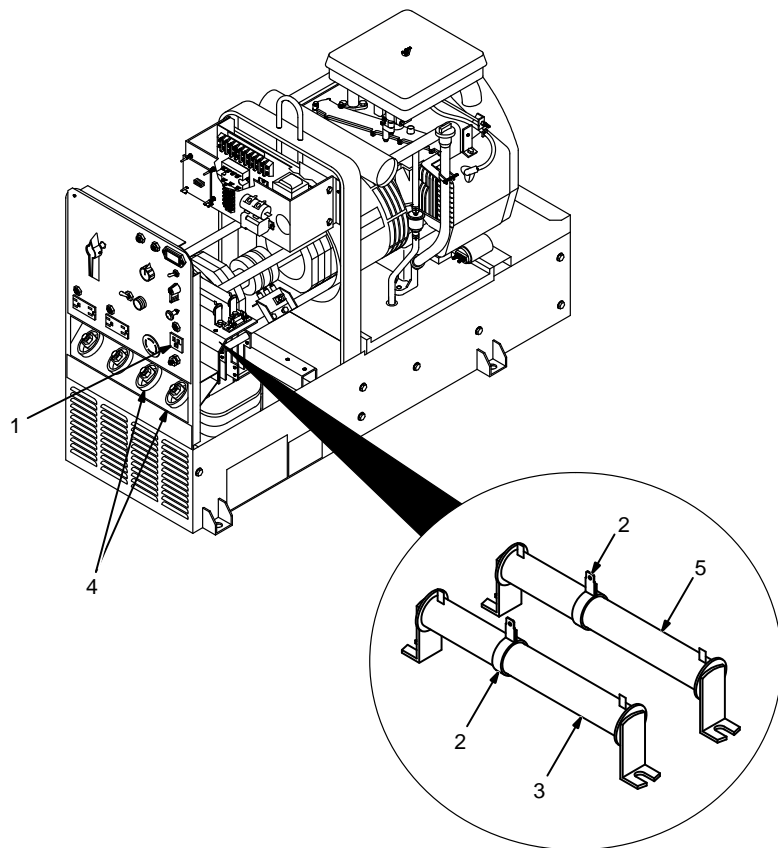
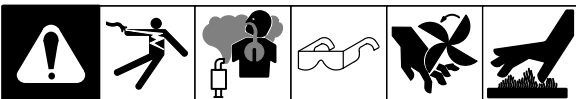

Check engine speeds, and adjust if necessary (see Section 8-5).

- 1 115 VAC 100 Hz Receptacle RC4

With no load applied and engine running at weld rpm, there should be 128 to 132 volts ac present at RC4.

- 2 Slider
- 3 Resistor R4

▲ Stop engine before adjusting R4

If necessary, adjust slider on R4 until 128 to 132 volts ac is obtained at RC4. Do not exceed 132 volts ac.

- 4 DC Weld Output Terminals

Turn Fine Amperage control R1 to max. With no load applied and engine running at weld rpm, there should be 70 to 72 volts dc present at dc weld terminals.

- 5 Resistor R2

▲ Stop engine before adjusting R2

If correct voltage is not present, adjust slider on R2 until correct voltage is obtained at dc weld terminals. Do not exceed 72 volts dc.

Stop engine. Allow engine to cool, and then complete pre-operational checks in table.

Reinstall cover and side panels.

Pre-Operational Checks

Wipe engine surfaces clean.
Check labels; replace labels that are unreadable or damaged.
Check fuel and oil (see Section 2-4).
Check and correct any fluid leaks.
Clean weld output and battery terminals. Tighten connections.
Clean outside of entire unit.

Tools Needed:

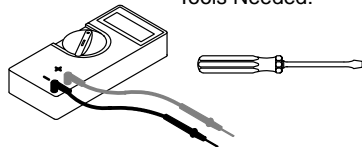

Ref. ST-800 698-A / ST-800 249

SECTION 7 – DISASSEMBLY AND REASSEMBLY

7-1. Disassembly Of Unit

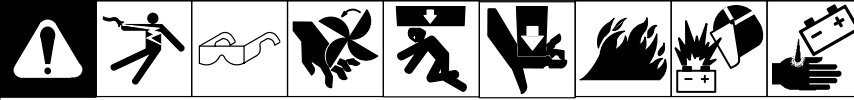

Use Section 6-1 to determine if trouble is in rotor, stator, engine or a combination of these components.

Remove sheet metal panels from unit. Disconnect negative (-) battery cable from battery. Remove spark plugs. Mark and disconnect all stator leads.

▲ Do not damage rotor or stator during this procedure.

Use hoist and lifting strap to remove the engine/generator assembly.

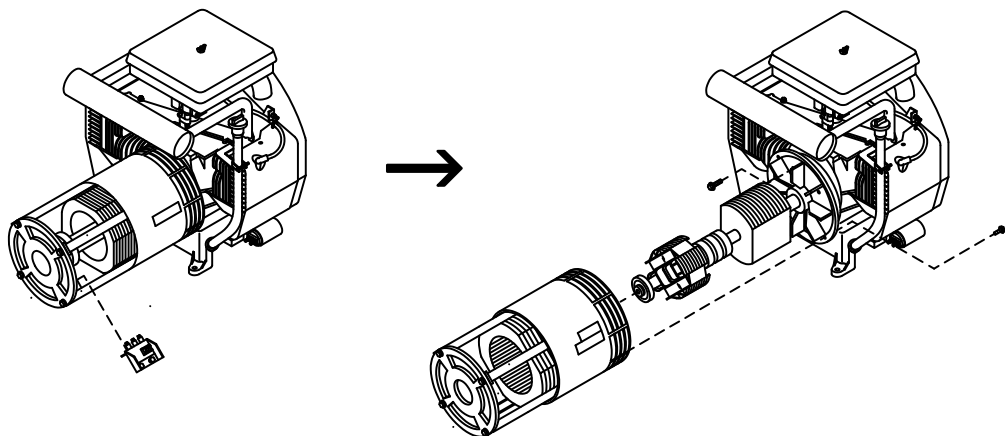
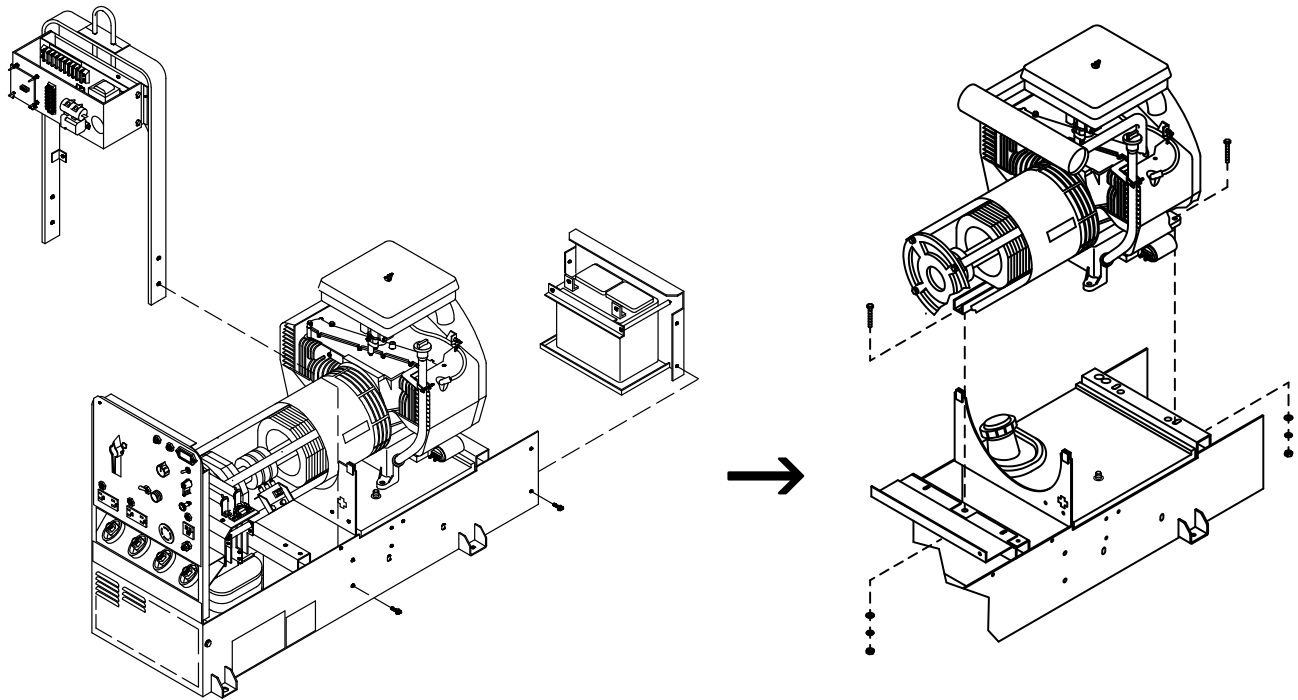

Tools Needed:

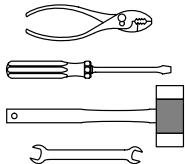

3/8, 7/16, 1/2, 9/16 in

ST-800 710-A

7-2. Disassembly Of Generator

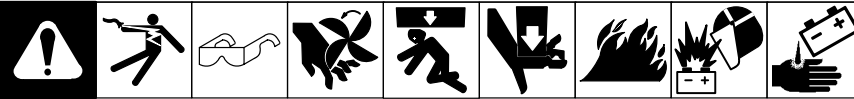

Hardware may differ from that shown.

Torques:			
Prior To Serial No. KD523655		Effective With Serial No. KD523655	
A	15 ft lb (20 N·m)	A	15 ft lb (20 N·m)
B	30 ft lb (41 N·m)	B	20 ft lb (27 N·m)
C	25 ft lb (34 N·m)	C	25 ft lb (34 N·m)
D	15 ft lb (20 N·m)	D	20 ft lb (27 N·m)
E	15 ft lb (20 N·m)	E	15 ft lb (20 N·m)

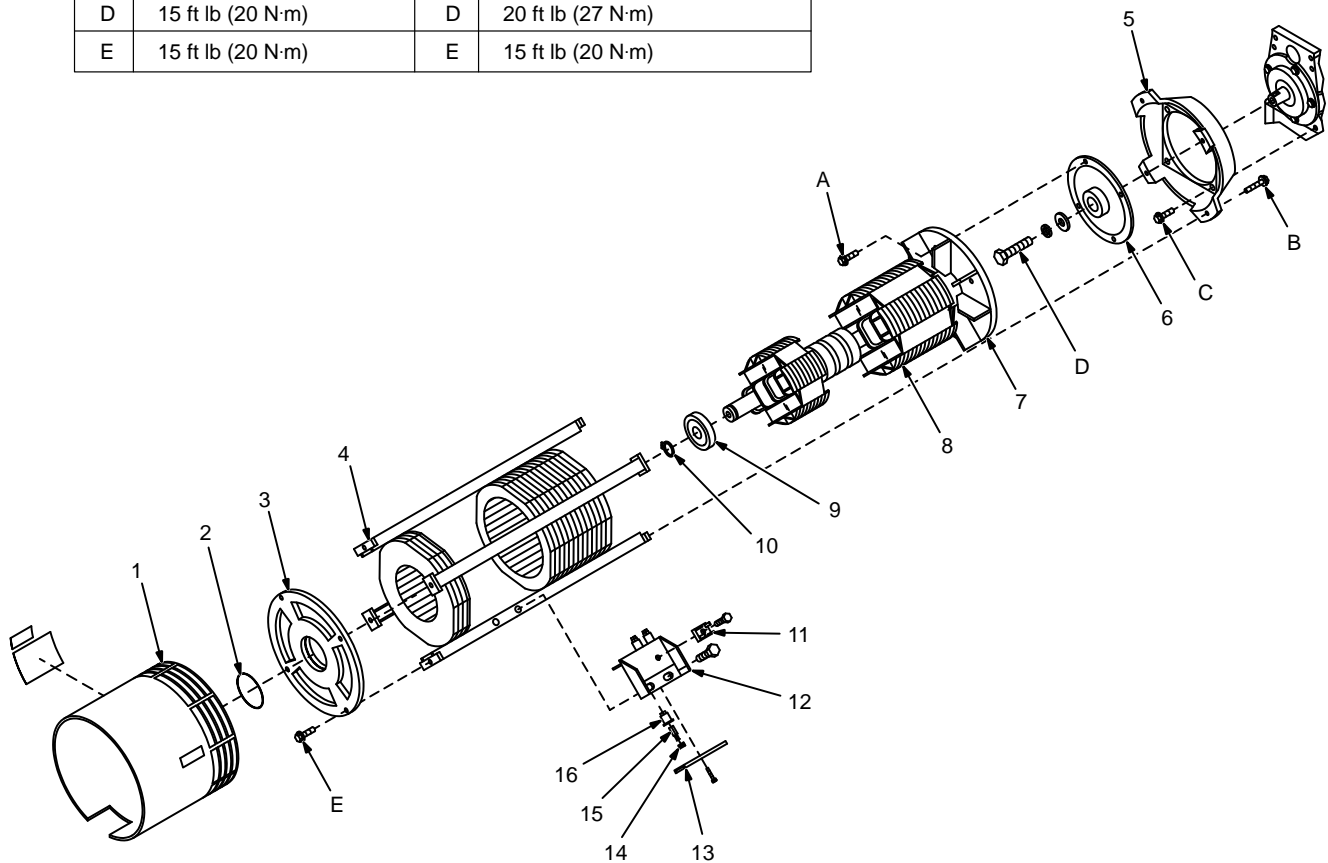

ST-115 942-F

▲ Do not damage stator or rotor windings during this procedure.

Disassembly

With engine properly supported with blocks, remove hardware securing stator to engine.

Remove generator parts as needed:

- 1 Fan Guard
- 2 O-Ring
- 3 Endbell
- 4 Stator Assembly
- 5 Engine Adapter

- 6 Fan Rotor Adapter
- 7 Rotor Fan
- 8 Rotor
- 9 Ball Bearing
- 10 Retaining Ring
- 11 Integrated Rectifier SR2
- 12 Brush Holder Bracket
- 13 Brush Holder Retaining Bar
- 14 Brush Holder Cap
- 15 Brush

- 16 Brush Holder

Reassembly

Reinstall engine and generator parts as needed (see torque table).





















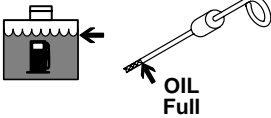

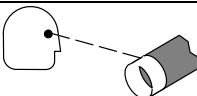

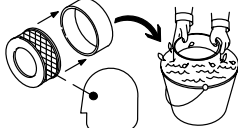
Reconnect fuel line, choke cable, and base ground cable. Reinstall spark plugs, battery and tray, panels, and cover.

Use cable ties to secure leads in existing wiring harnesses and away from moving or hot parts.

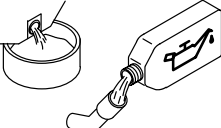
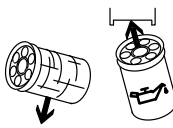
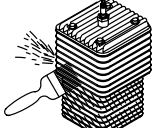
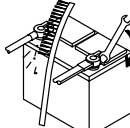
Reconnect negative (-) battery cable.

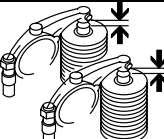
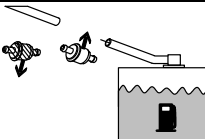
SECTION 8 – MAINTENANCE

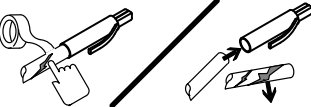
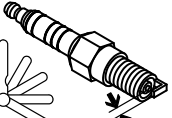
8-1. Routine Maintenance

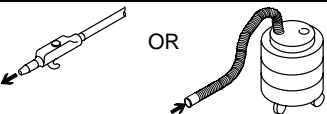
							 Recycle engine fluids.	<p>▲ Stop engine before maintaining.</p> <p>☞ See also Engine Manual and maintenance label. Service engine more often during severe conditions.</p>
 8 Hours								
				Wipe Up Spills				Check Fluid Levels. See Section 2-4
 20 Hours								
				Check And Clean Spark Arrester Screen				
 25 Hours								
				Clean And Check Air Cleaner				
 50 Hours								
				Clean And Tighten Weld Terminals				
 100 Hours								
				Change Oil. See Section 8-4 And Maintenance Label				Change Oil Filter. See Section 8-4 And Maintenance Label
				Clean Cooling System, See Engine Manual				Clean And Tighten Battery Connections
 200 Hours								
				Check Valve Clearance				Replace Fuel Filter. See Section 8-4.
								Replace Unreadable Labels
 500 Hours								
				Repair Or Replace Cracked Cables				Check Spark Plugs
 1000 Hours								
				Blow Out Or Vacuum Inside. During Heavy Service, Clean Monthly				

8-2. Maintenance Label

ONAN P218 GAS ENGINE



See Engine Manual for complete engine care. Give engine Specification and Serial Number when ordering parts.

Recommended Oil . . . API Service Classification
SF, SG, SF/CC, SG/CE

Oil & Filter Change
dirty conditions . . . 25 hours or less
normal conditions . . 100 hours

Oil Filter MILLER 065 251, Onan 122-0645

Oil Capacity 1.5 qt (1.4 L) or 1.75 qt (1.6 L) with filter change



Check daily.

To Drain Oil:

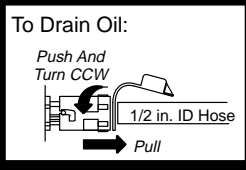

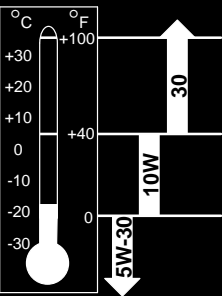



Gasoline

Fuel Grade Regular or Unleaded

Fuel Filter MILLER 066 113, Onan 149-2206-01,
Fram G10E1



Air Filter Service 100 hours or less – see Owner's Manual

Air Filter Element MILLER 064 617, Onan 140-2522

Air Filter Wrapper MILLER 065 653, Onan 140-1496



12 Volt Battery BCI Group 58

Cranking Performance at 0°F (-18°C) 430 Amps min.



Engine RPM – No Load
Power . . . 1650 (50 Hz)
 1860 (60 Hz)

Weld 3000



Valve Clearance – Cold
In. . . . 0.005 in (0.13 mm)
Ex. . . . 0.013 in (0.33 mm)



Spark Plug Gap 0.025 in. (0.6 mm)

Spark Plug Champion RS17YX Preferred or
RS14YC

Use only resistor spark plugs and wires.



Optional

Spark Arrester Inspection And Service . 20 operating hours -
see Owner's Manual

S-176 891

8-3. Servicing Air Cleaner

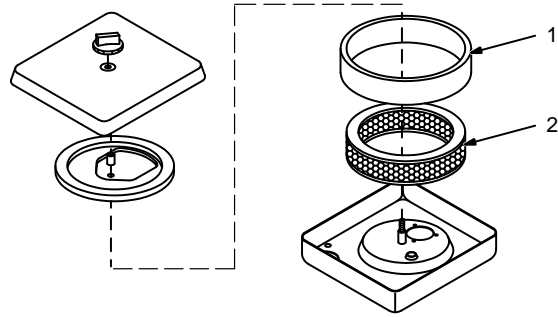

▲ Do not run engine without air cleaner or with dirty element.

Stop engine.

1 Precleaner

Wash precleaner with soap and water solution. Allow precleaner to air dry completely.

Spread 1 tablespoon SAE 30 oil evenly into precleaner. Squeeze out excess oil.

2 Element

Replace element if dirty or oily.

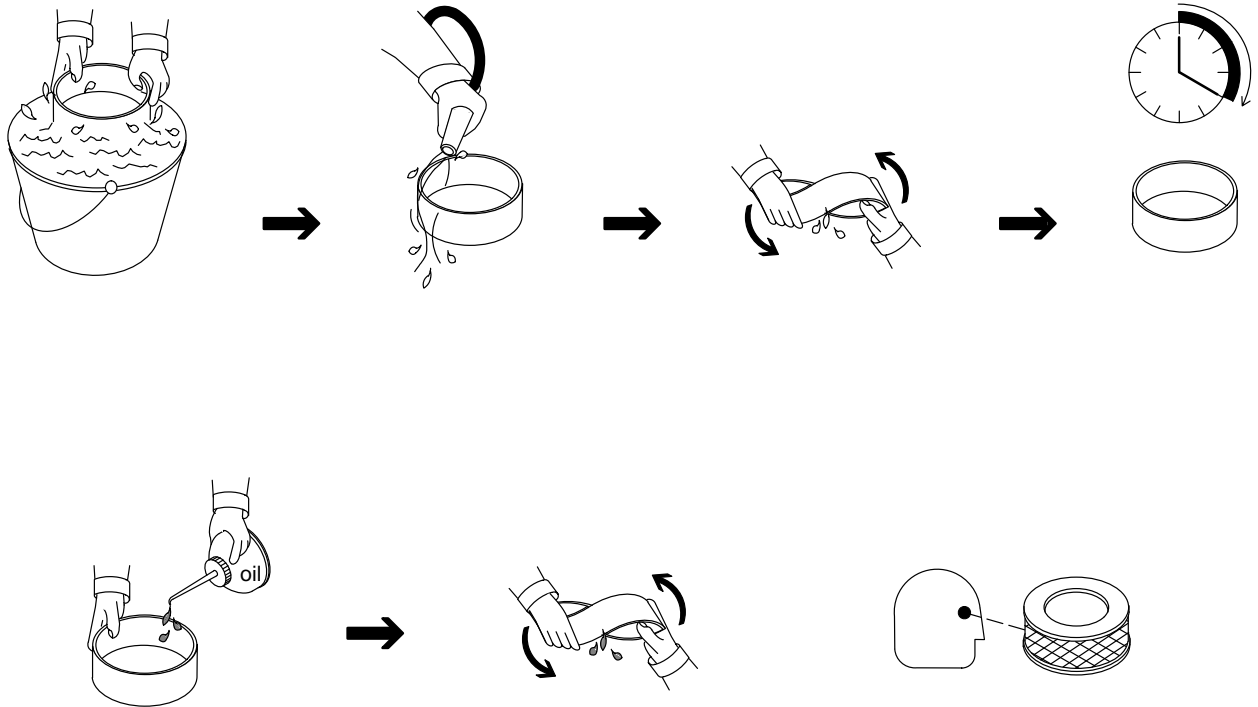

aircleaner3 1/96 – ST-156 852 / S-0759

8-4. Changing Engine Oil, Oil Filter, And Fuel Filter

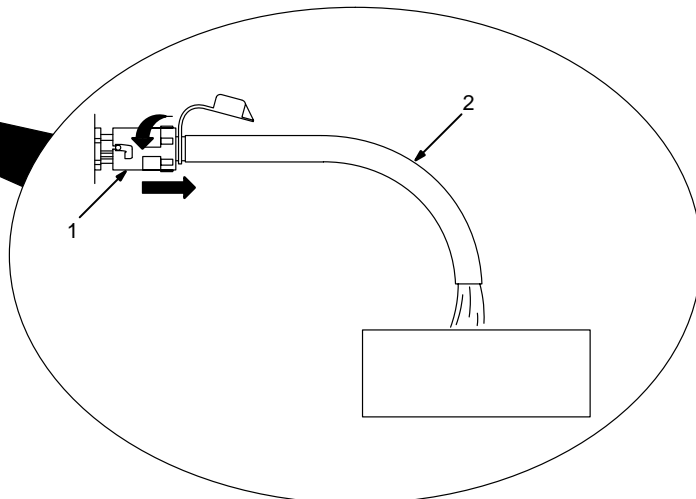
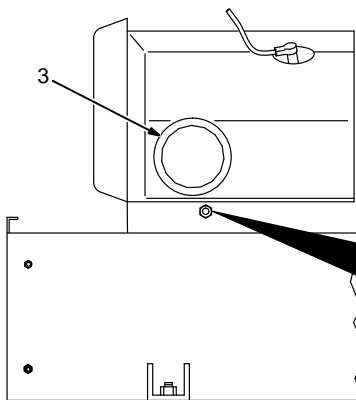
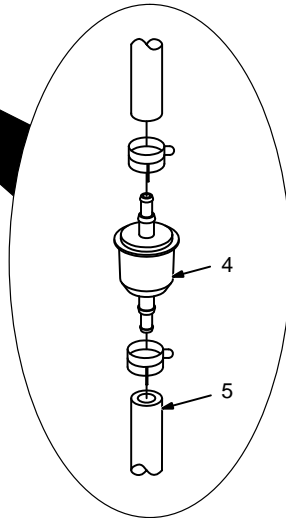
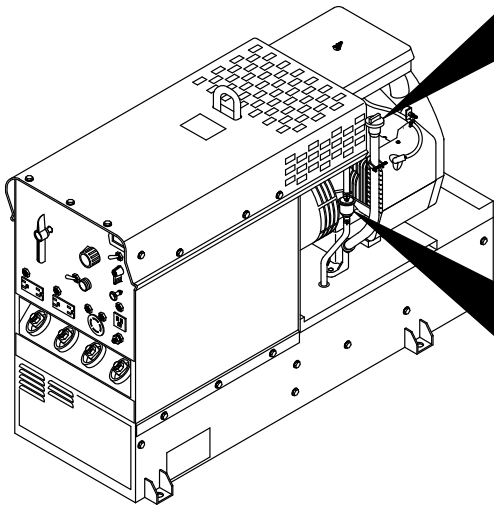
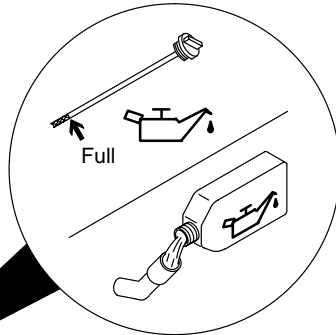
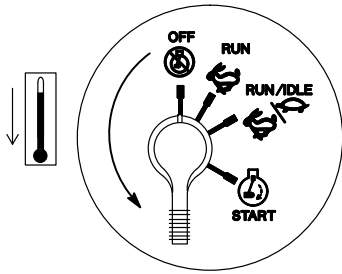

Tools Needed:

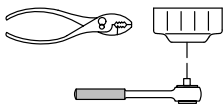

Stop engine and allow to cool.

- 1 Oil Drain Valve
- 2 1/2 ID x 12 in Hose
- 3 Oil Filter

Change engine oil and filter according to engine owner's manual.

▲ **Close valve and valve cap before adding oil and running engine.**

Fill crankcase with new oil to full mark on dipstick (see Section 8-2).

- 4 Fuel Filter
- 5 Fuel Line

Replace line if cracked or worn. Install new filter. Wipe up any spilled fuel.

Start engine, and check for fuel leaks.

Stop engine, tighten connections as necessary, and wipe up fuel.

8-5. Adjusting Engine Speed

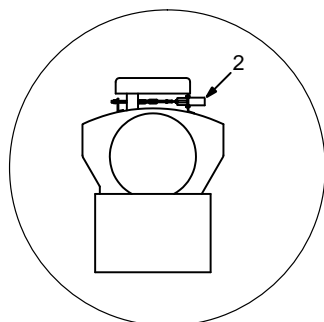

Rear View

	1860 rpm (Power/Idle)
	3000 rpm (Weld)

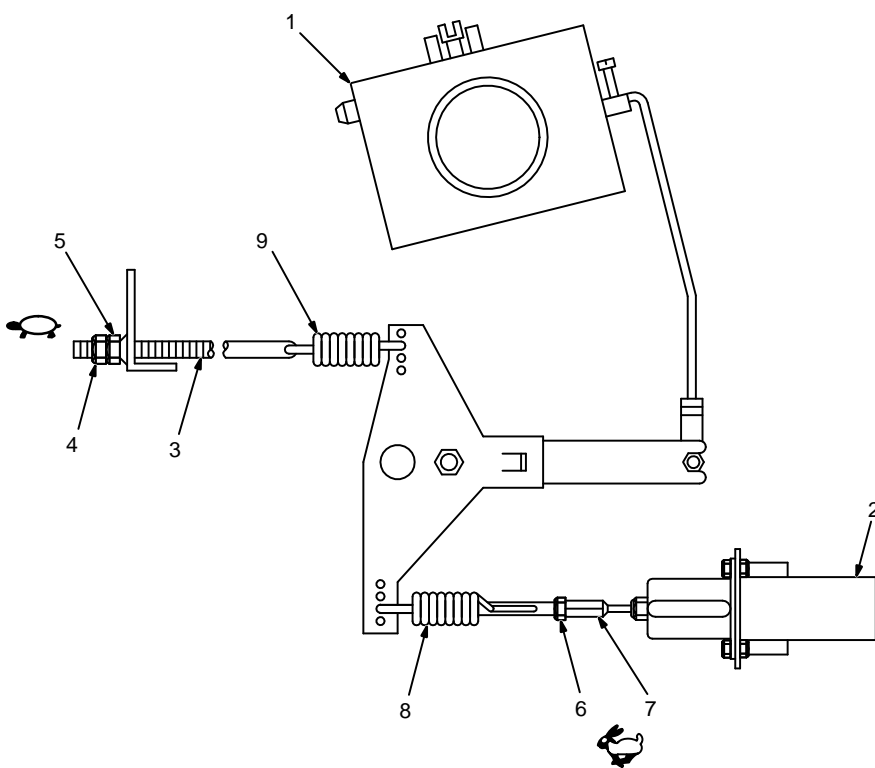

Top View

Tools Needed:

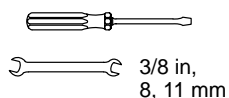

After tuning engine, check engine speeds with a tachometer. See table for proper no load speeds. If necessary, adjust speeds as follows:

Start engine, and place Engine Control switch in Run/Idle position. Turn Fine Amperage control to 100.

- 1 Carburetor
- 2 Throttle Solenoid

Power/Idle Speed Adjustment

- 3 Power/Idle Speed Rod
- 4 Lock Nut
- 5 Adjustment Nut

Loosen lock nut and rotate adjustment nut until engine runs at power/idle speed. Tighten lock nut.

Weld Speed Adjustment

Place Engine Control switch in Run position.

- 6 Lock Nut

Loosen nut.

- 7 Hex Swivel

Turn swivel until engine runs at weld speed. Tighten lock nut.

- 8 Weld Speed Governor Spring
- 9 Power/Idle Speed Governor Spring

If a spring becomes loose or disconnected, reattach as shown.

ST-116 049-C

8-6. Overload Protection

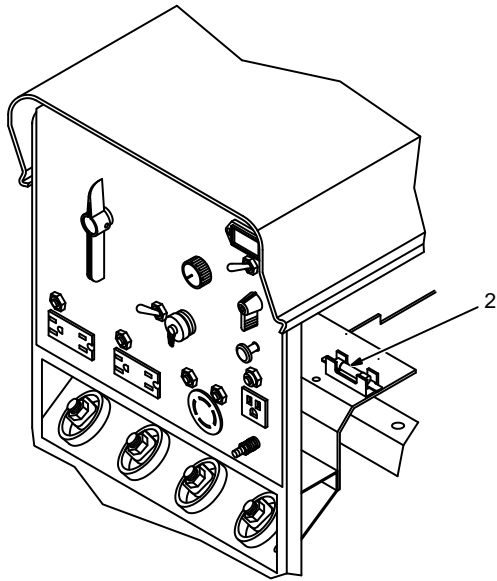

Tools Needed:

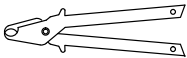

3/8 in

Stop engine.

- 1 Circuit Breaker CB4 (Internal – Not Shown)

CB4 protects the unit from overload due to an obstructed throttle solenoid. If CB4 opens, engine speed drops to power/idle rpm for about 10 seconds before automatically resetting.

If CB4 continues to open, check throttle solenoid TS1 and throttle linkage.

- 2 Fuse F1 (See Parts List For Rating)

F1 protects the exciter excitation winding from overload.

Replace open fuse and reinstall panel before operating unit.

If F1 continues to open, check integrated rectifier SR2 and rotor.

ST-152 264-A

8-7. Inspecting And Cleaning Optional Spark Arrestor

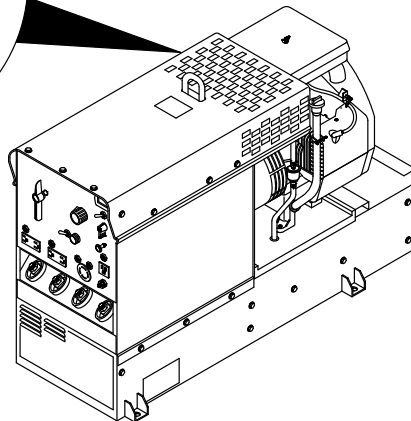
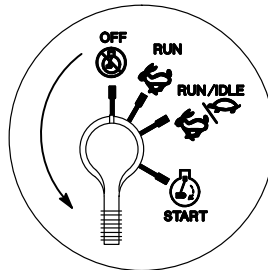
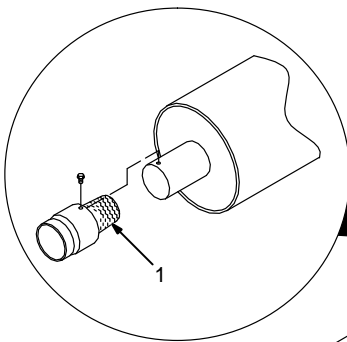

Tools Needed:

1/4 in



Stop engine and allow to cool.

- 1 Spark Arrestor Screen

Clean and inspect screen. Replace spark arrestor if screen wires are broken or missing.

ST-140 091-E / ST-801 206 / Ref. ST-168 046

SECTION 9 – ELECTRICAL DIAGRAMS

 The circuits in this manual can be used for troubleshooting, but there might be minor circuit differences from your machine. Use circuit inside machine case or contact factory for actual circuit, if needed.

The following is a list of all diagrams for models covered by this manual. To order a copy, proceed as follows:

- 1 Know unit Model and Serial or Style Number.
- 2 Use this list to find diagram number.
- 3 Include your FAX number or mailing address with your request.
- 4 FAX Technical Publications Department at 414-735-4011 or call 414-735-4356.

Model	Serial Or Style Number	Circuit Diagram	Wiring Diagram	Main Reason For Change
Miller Legend Without Remote Control	JH242114 thru JH300533	SC-114 477-A	D-117 651◆◆	
	JH300534 thru JJ420470	C-117 626-B◆◆	D-123 101◆◆	Changed PC1 and S1, added D5
	JJ420471 thru JK713331	C-123 087-B◆◆	D-130 651-A◆◆	Added D6
	JK713332 thru KA780043	SC-130 929◆◆	D-130 651-A◆◆	Removed S1
	KA780044 thru KA870083	C-135 624◆◆	D-135 628◆◆	Removed F2
	KA870084 thru KD346697	C-137 000-A◆◆	D-136 855-D◆◆	Added S1
	KD346698 thru KD438828	C-157 770◆◆	D-157 767-A◆◆	Added PC4, PC5
	KD438829 thru KD548029	C-162 148◆◆	D-162 146◆◆	Added stator lead 33
	KD548030 thru KE604175	C-166 823◆◆	D-166 822◆◆	Hourmeter standard
	KE604176 thru KE629033	C-167 423◆◆	D-167 422◆◆	Changed PC2
	KE629034 and following	SC-168 053-A	SD-168 051-B	Added CB5, CB7, D8, GFCI
Miller Legend With Remote Control	JH242114 thru JH300533	SC-115 947-A		
	JH300534 thru JJ420470	C-118 207-A◆◆		Changed PC1 and S1, added D5
	JJ420471 thru JK713331	C-123 088-B◆◆		Added D6
	JK713332 thru KA780043	C-130 928◆◆		Removed S1
	KA780044 thru KA870083	C-135 801◆◆		Removed F2
	KA870084 thru KD346697	C-137 003-B◆◆		Added S1
	KD346698 thru KD438828	C-157 764◆◆		Added PC4, PC5
	KD438829 thru KE604175	C-162 147◆◆		Added stator lead 33
	KE604176 thru KE629033	C-167 402◆◆		Hourmeter standard, changed PC2
	KE629034 and following	SC-168 054-A		Added CB5, CB7, D8, GFCI
Circuit Board PC1	JH242114 thru JH300533	SB-113 710		
Circuit Board PC2	JH242114 thru KE604175	B-049 506-C◆◆		
	KE604176 and following	SB-160 891		
Circuit Board PC3◆	JH242114 thru KA840709	B-115 891-A◆◆		
	KA840710 and following	SB-136 249		
Circuit Board PC4	KD346698 and following	SA-148 024-A		
Circuit Board PC5◆	KD346698 and following	SB-156 027		

◆ Optional ◆◆ Not included in this manual

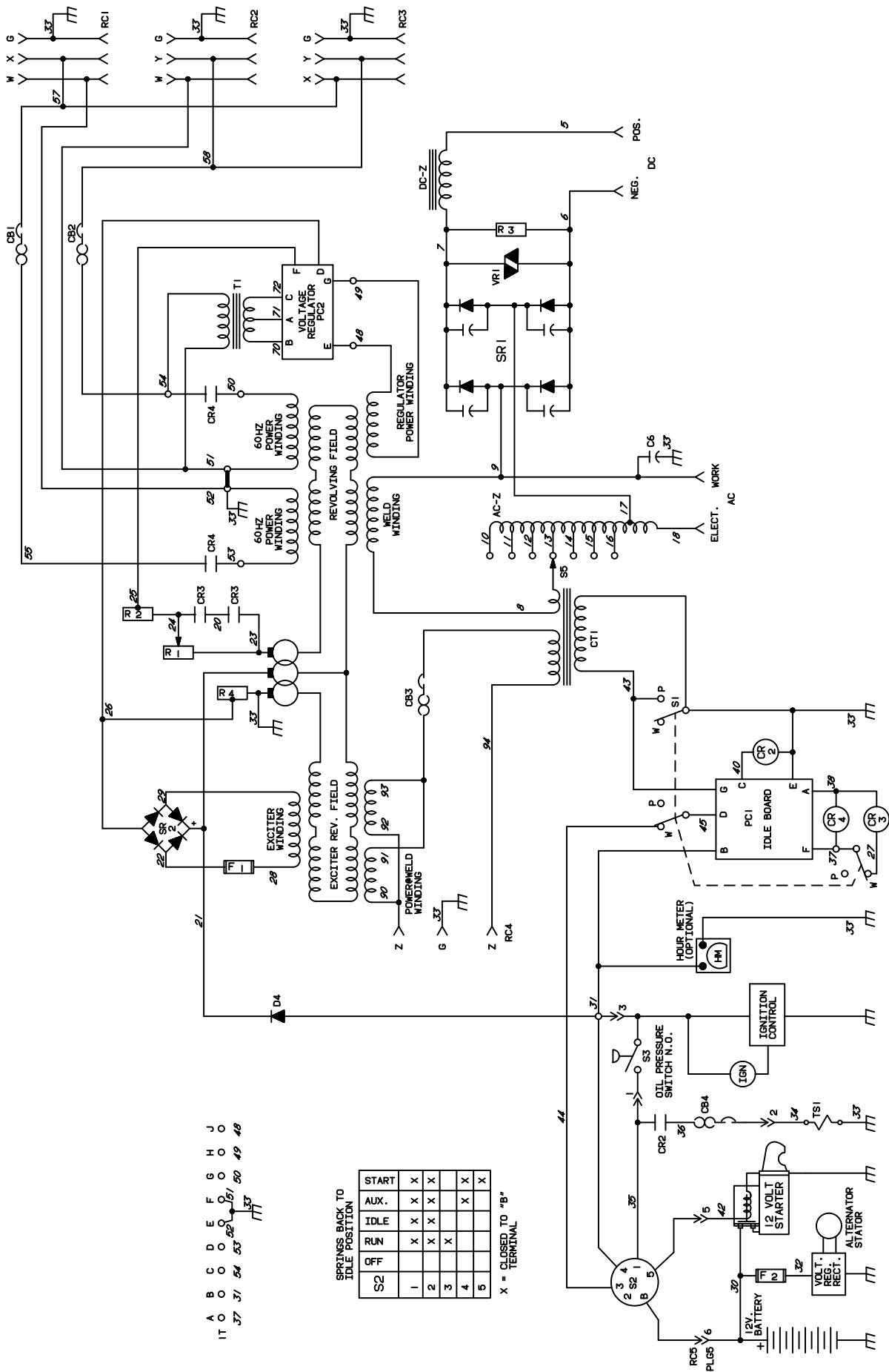

Figure 9-1. Circuit Diagram For Miller Legend Without Remote Control Effective With Serial No. JH242114 Thru JH300533

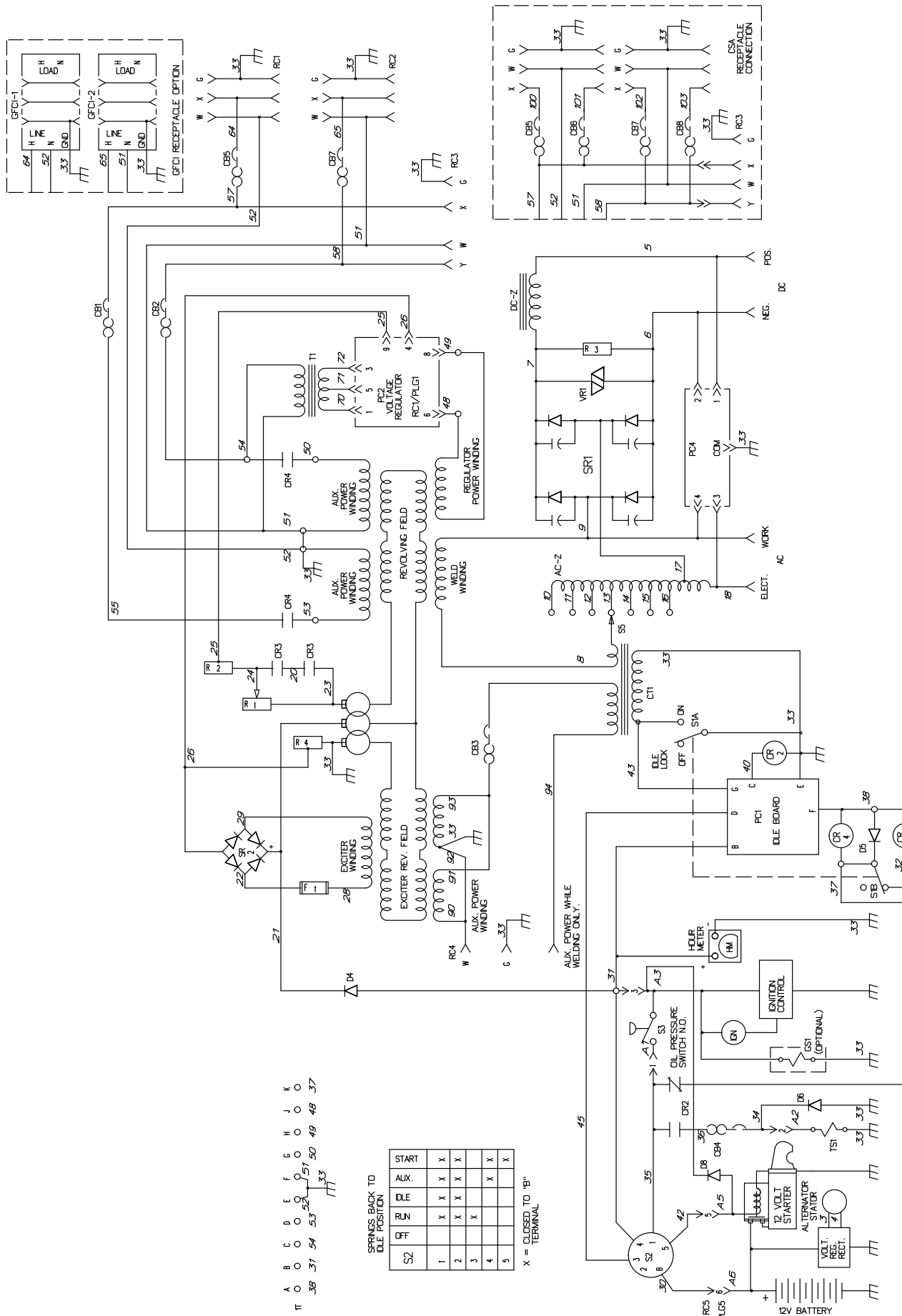
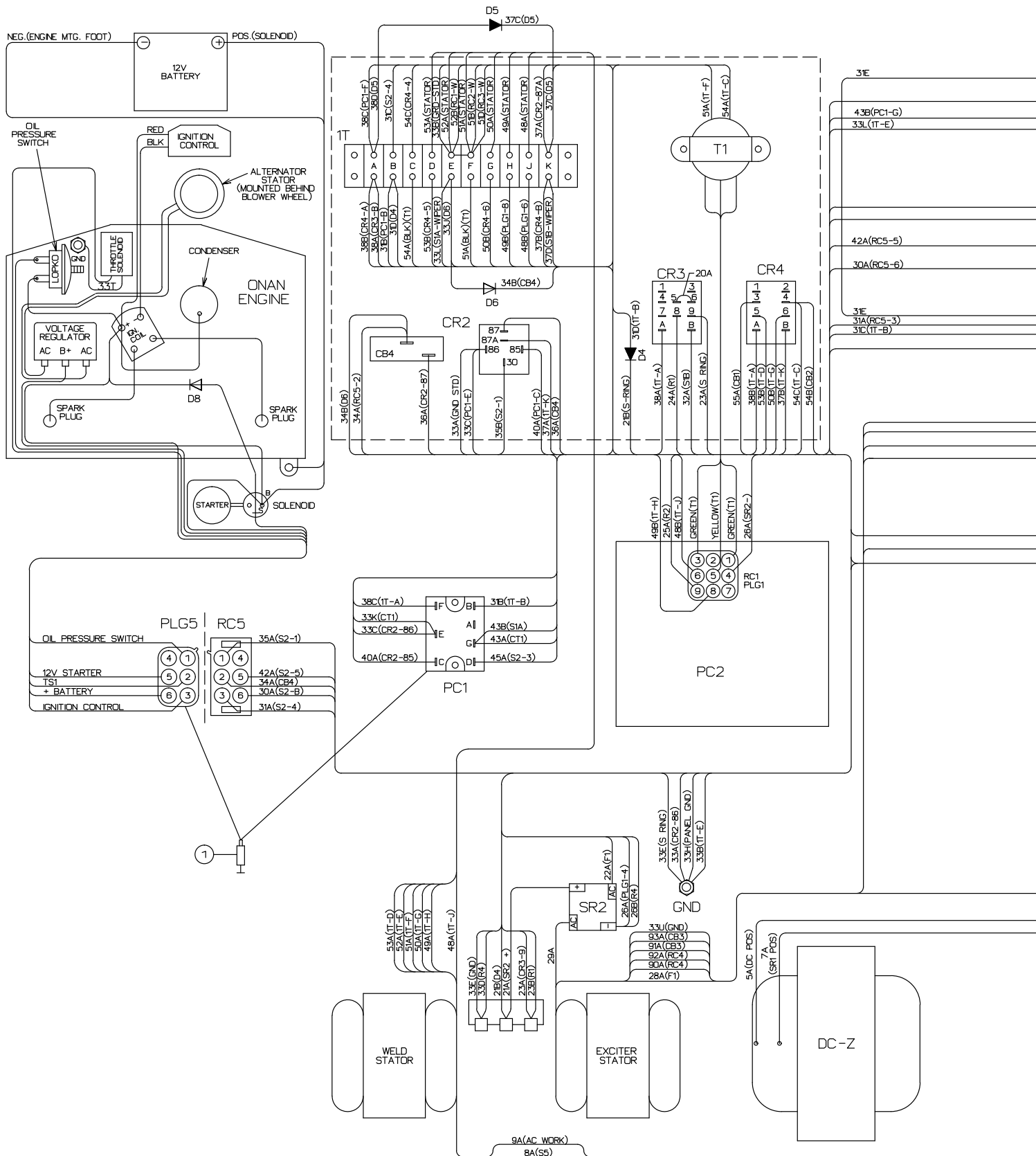
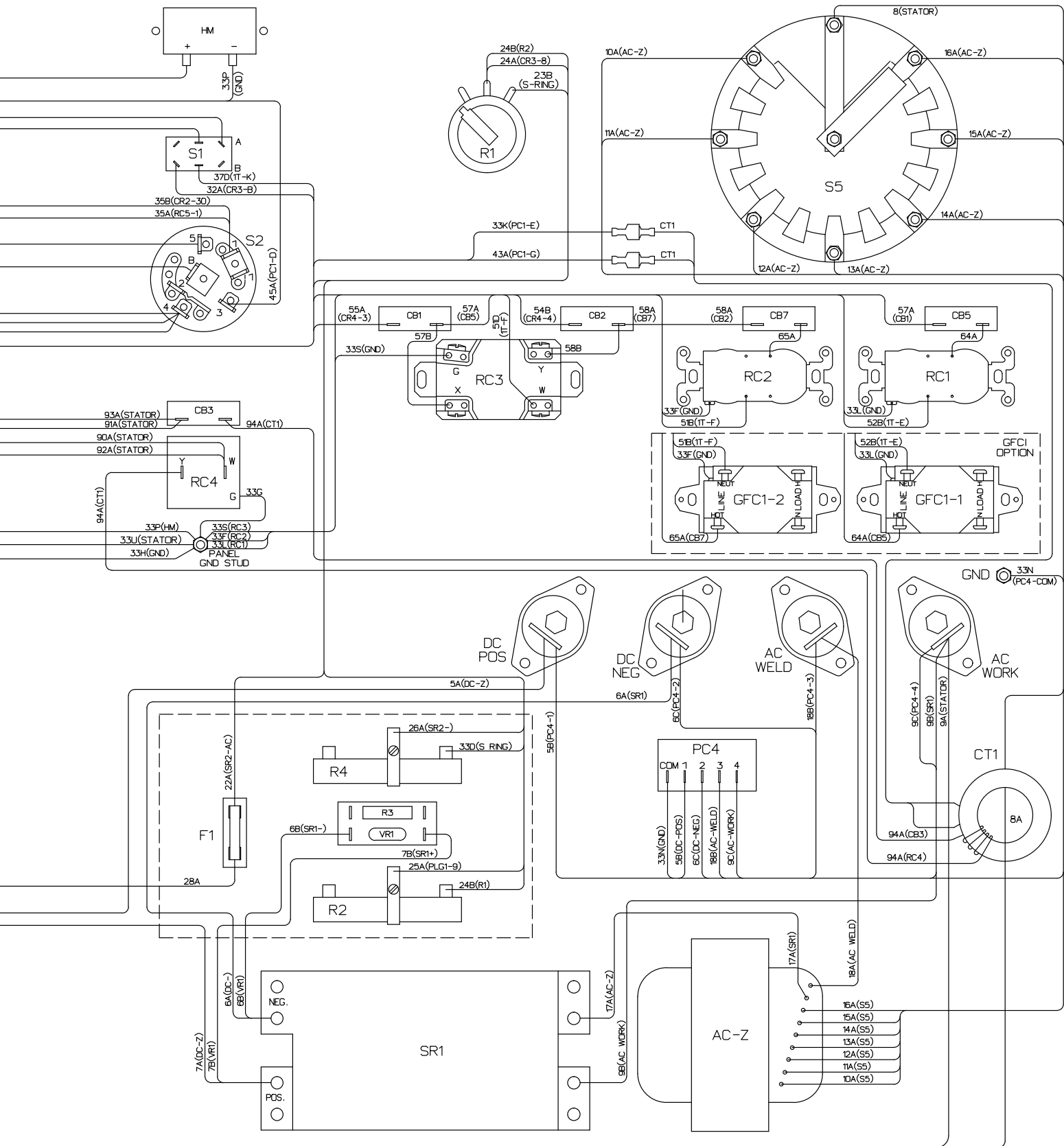

Figure 9-2. Circuit Diagram For Miller Legend Without Remote Control Effective With Serial No. KE629034 And Following



Coat terminals with dielectric grade, nonconductive, electric grease (MILLER Part No. 146 557) or equivalent.

Figure 9-3. Wiring Diagram For Miller Legend Without Remote Control Effective With Serial No. KE629034 And Following



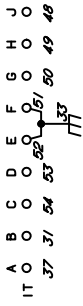
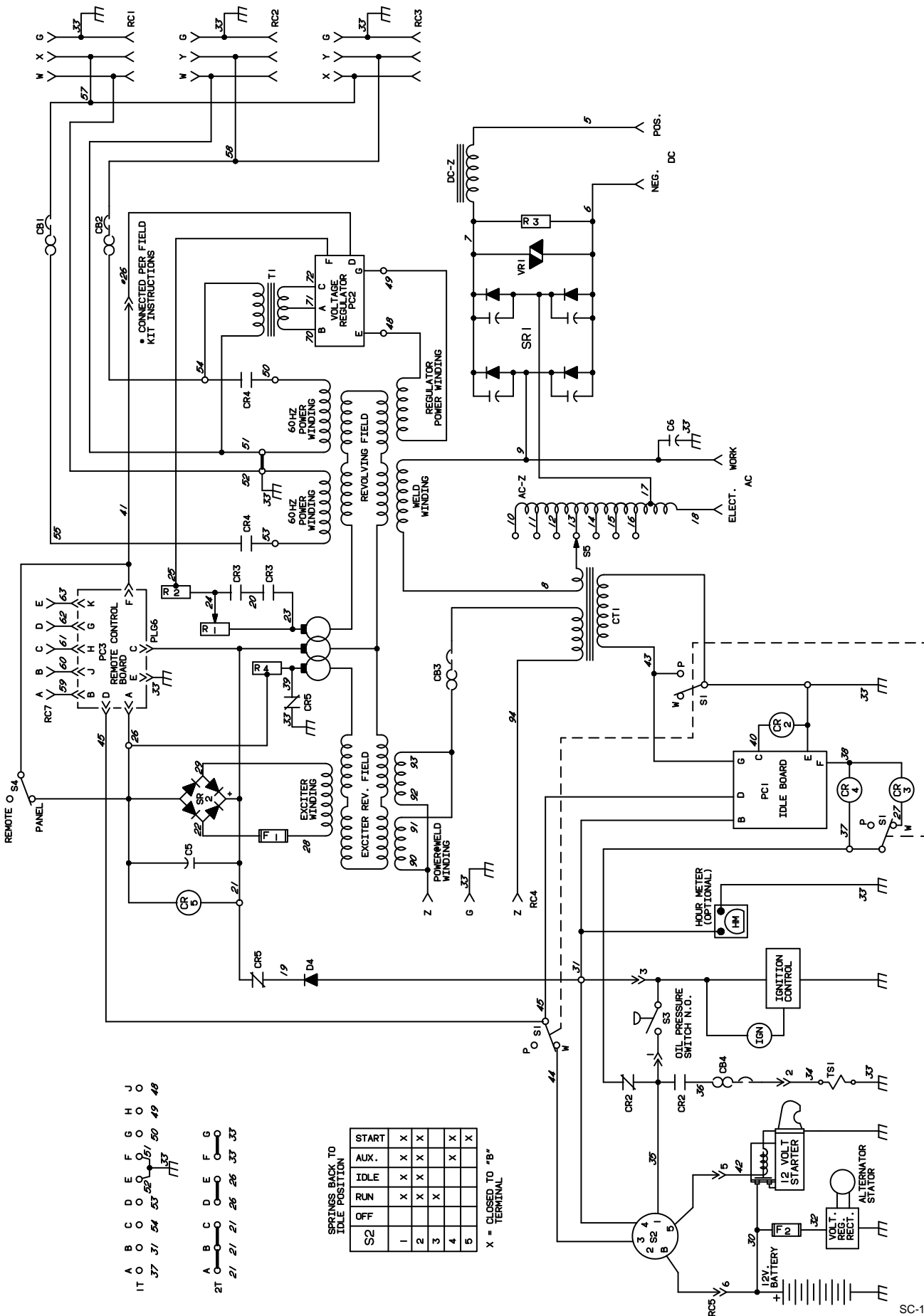

SPRINGS BACK TO IDLE POSITION

S2	1	2	3	4	5
START					
AUX.	X	X	X	X	X
IDLE	X	X	X	X	X
RUN	X	X	X	X	X
OFF					

X = CLOSED TO "B" TERMINAL

Figure 9-4. Circuit Diagram For Miller Legend With Remote Control Effective With Serial No. JH242114 Thru JH300533

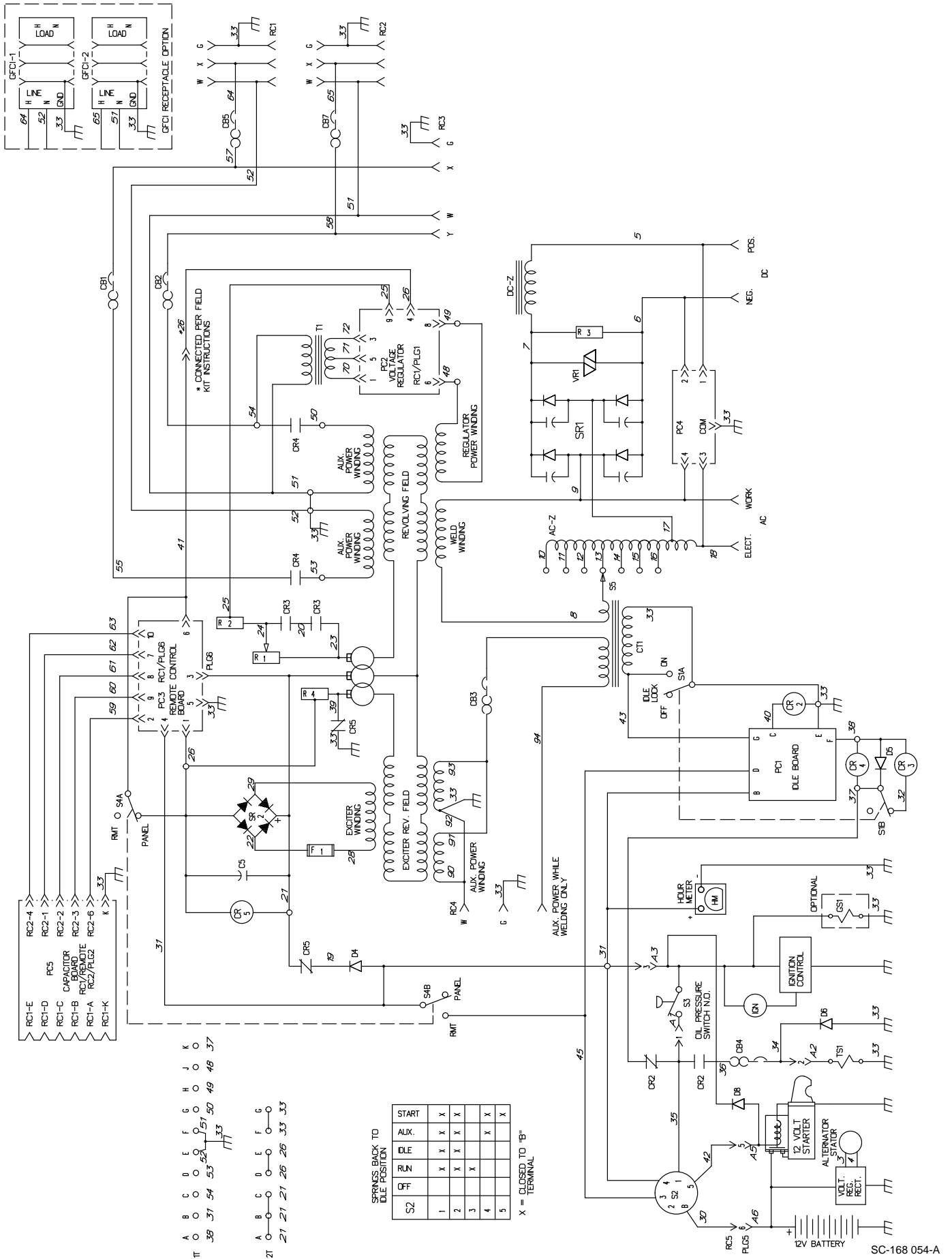
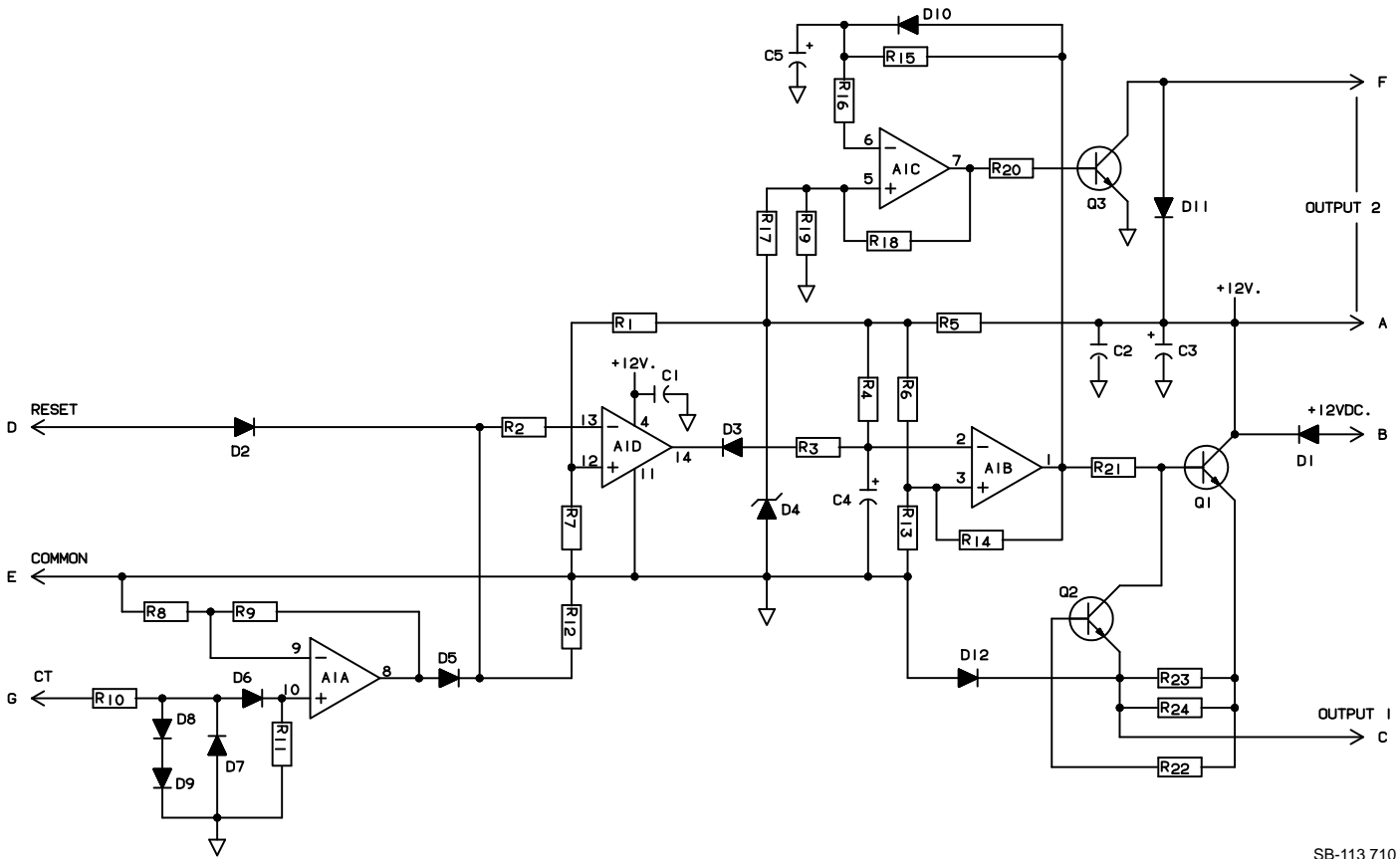
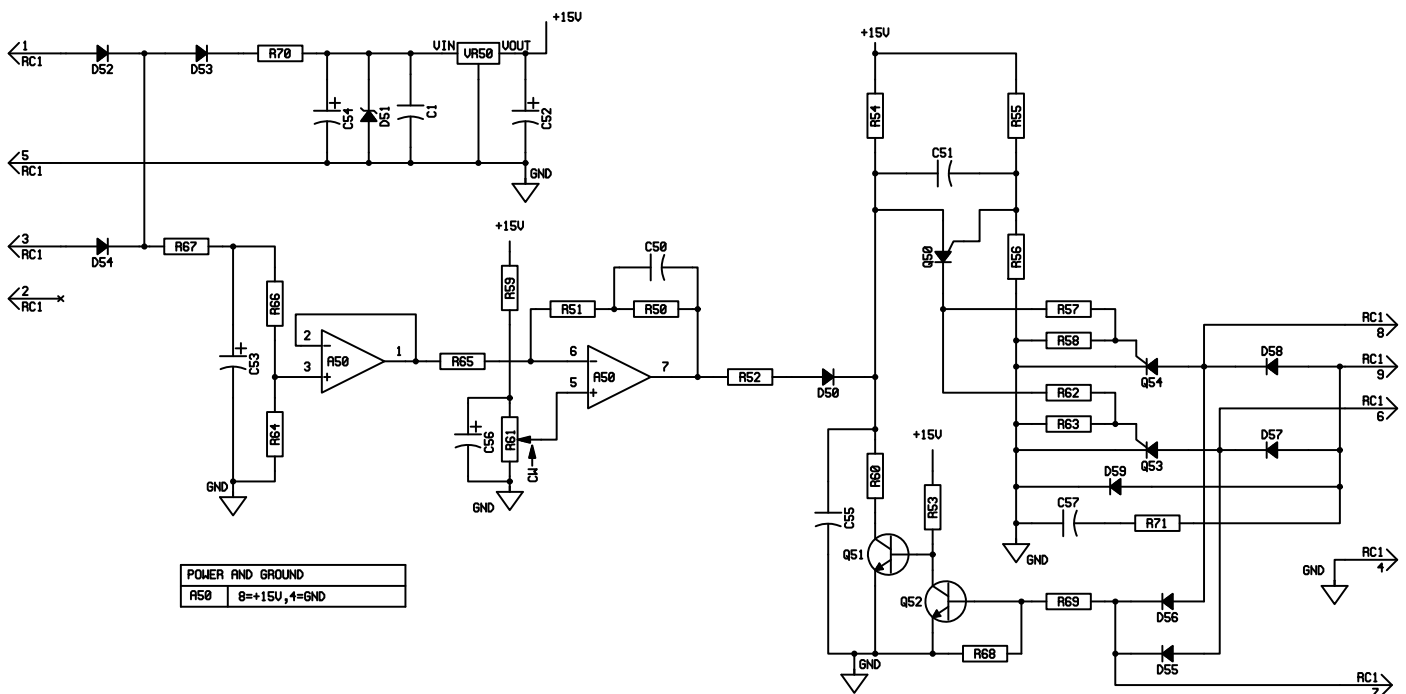

Figure 9-5. Circuit Diagram For Miller Legend With Remote Control Effective With Serial No. KE629034 And Following



SB-113 710

**Figure 9-6. Circuit Diagram For Idle Control Board PC1
Effective With Serial No. JH242114 Thru JH300533**



SB-160 891

**Figure 9-7. Circuit Diagram For Voltage Regulator Board PC2
Effective With Serial No. KE604176 And Following**

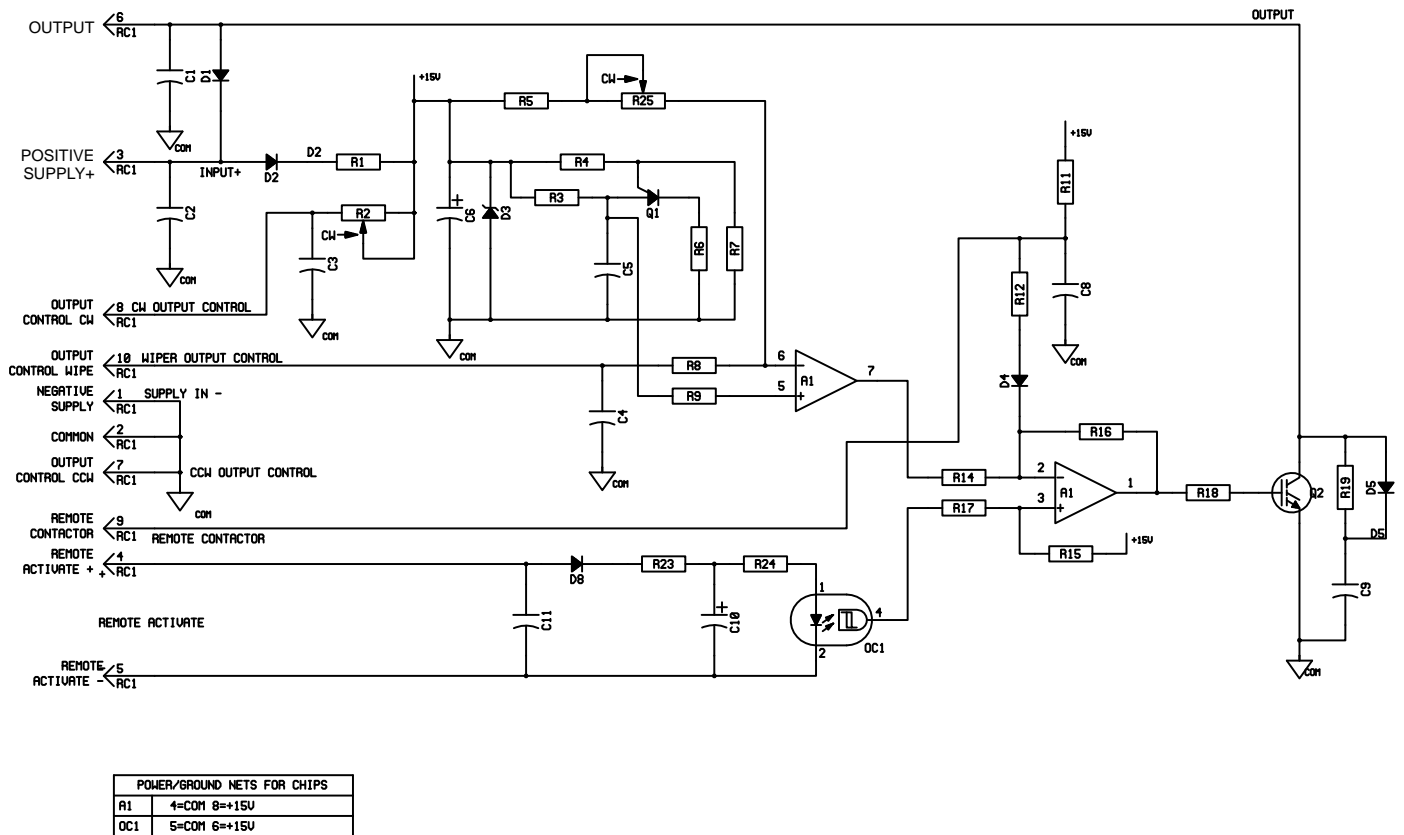

Figure 9-8. Circuit Diagram For Optional Remote Control Board PC3 Effective With Serial No. KA840710 And Following

SB-136 249

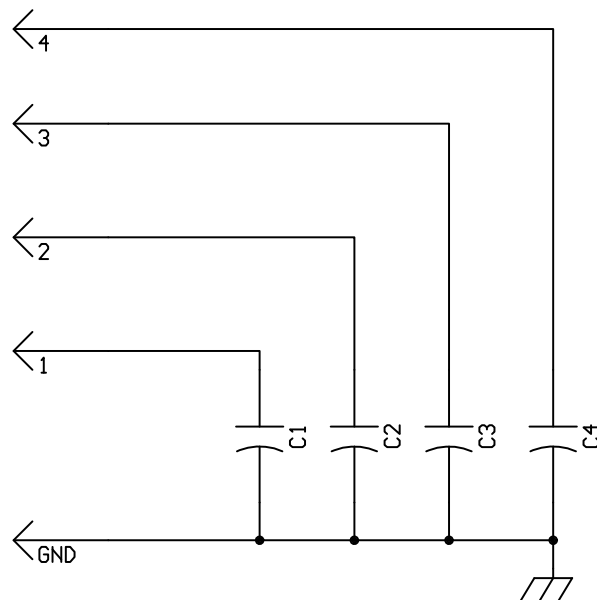
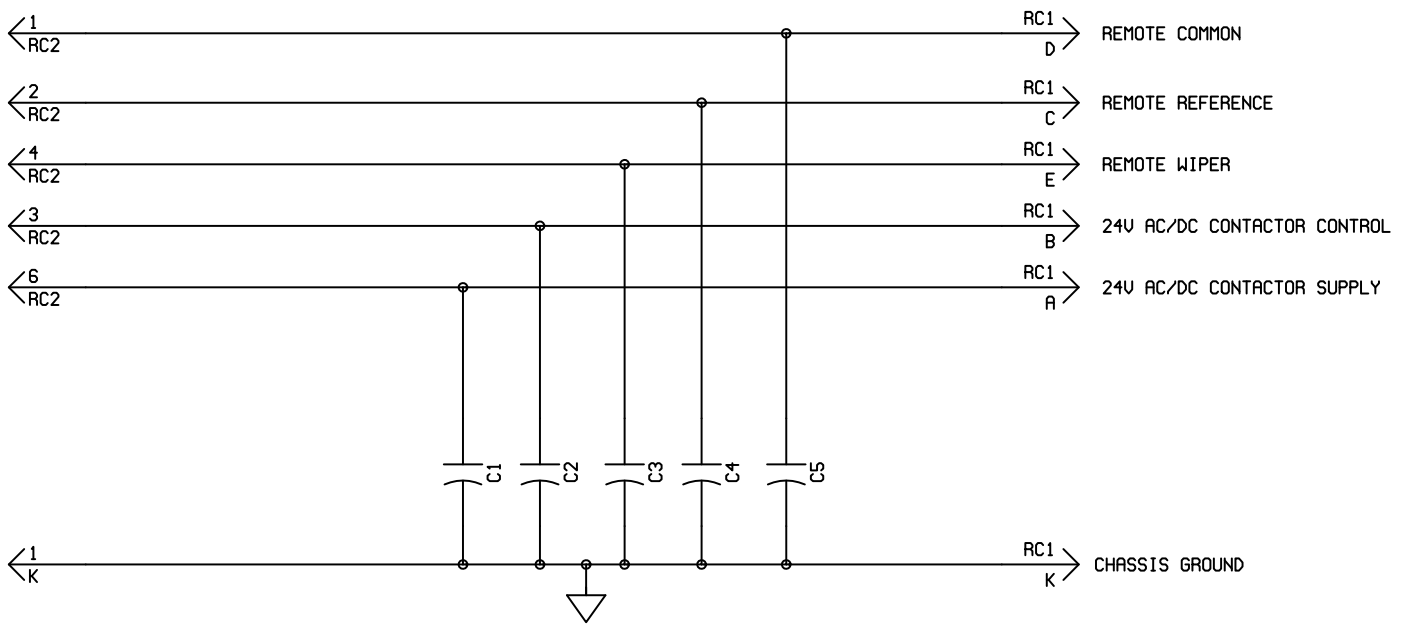

Figure 9-9. Circuit Diagram For HF Filter Board PC4 Effective With Serial No. KD346698 And Following

SB-148 024-A



SB-156 027

**Figure 9-10. Circuit Diagram For Optional Capacitor Board PC5
Effective With Serial No. KD346698 And Following**



Miller[®]

February 1996 Form: TM-428
Effective With Serial No. JH242114

SECTION 10 – PARTS LIST

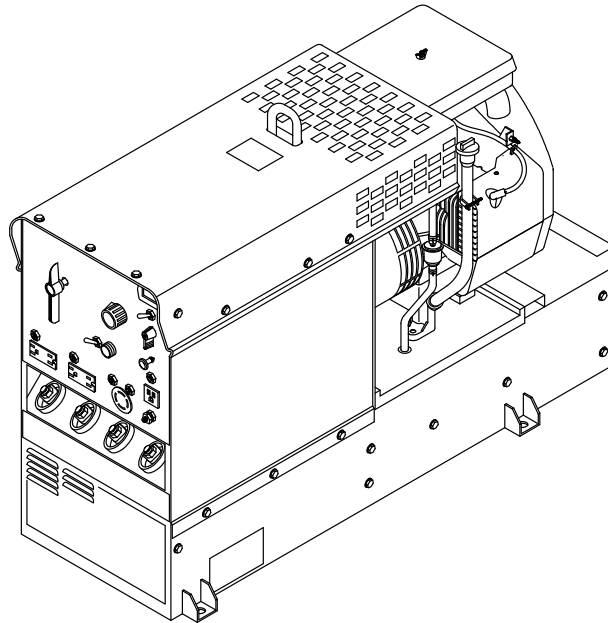

Miller Legend[®]

(Formerly The Legend[™] AEAD-200LE)

CC AC/DC Welding Generator For SMAW, GMAW, GTAW Welding

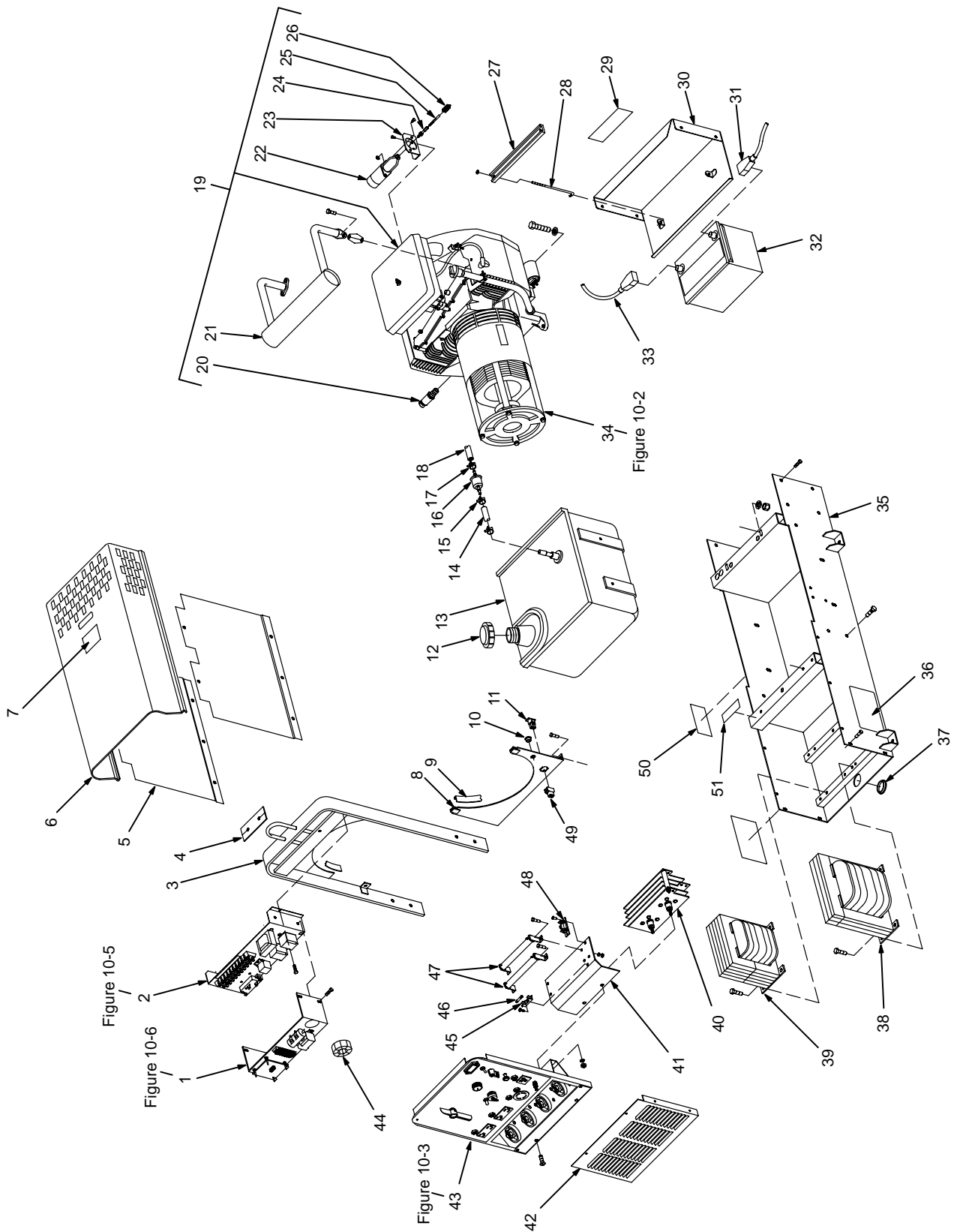

Figure 10-1. Main Assembly

Item No.	Dia. Mkgs.	Part No.	Description	Quantity
Figure 10-1. Main Assembly				
...	1	++042 132	REMOTE CONTROL, (Figure 10-6) (Prior to JK713332)	1
...	1	++042 383	REMOTE CONTROL, (Figure 10-6) (Eff w/JK713332)	1
...	2	Figure 10-5	CONTROL PANEL, w/components	1
...	3	113 302	UPRIGHT, base (Prior to KA780148)	1
...	3	129 384	UPRIGHT, base (Eff w/KA780148 thru KA892304)	1
...	3	136 057	UPRIGHT, base (Eff w/KA892305 and on)	1
...	4	107 342	SEAL, lift eye	1
...	5	113 303	PANEL, side	2
...	6	+113 304	COVER, top (Prior to JJ365634)	1
...	6	+114 557	COVER, top (Eff w/JJ365634 thru KF812088)	1
...	6	+173 209	COVER, top (Eff w/KF812089)	1
...		120 304	BLANK, snap-in nyl .250mtg hole (Eff w/JJ365634 thru KB133271)	2
...		143 397	BLANK, snap-in nyl .312mtg hole (Eff w/KB133272 thru KF812088)	2
...	7	108 487	LABEL, warning falling equipment etc	1
...	8	113 439	PANEL, rear lower (Prior to KA780148)	1
...	8	128 789	PANEL, rear lower (Eff w/KA780148 thru KA892304)	1
...	8	136 059	PANEL, rear lower (Eff w/KA892305 and on)	1
...	9	095 970	STRIP, nprn wsl eng firewall 18 in	2
...	10	088 731	BUSHING, snap-in nyl .375 ID	1
...	11	PLG5	HOUSING, (part of engine wiring harness)	
...		113 248	TANK, fuel (Prior to KA780148) (consisting of)	1
...		015 603	CAP, tank fuel	1
...		107 345	NECK, tank fuel	1
...		113 685	TUBE, pick up fuel	1
...		010 863	CLAMP, hose 2 1/16-3 clamp dia (Prior to KA780148)	2
...		107 346	HOSE, fuel tank (Prior to KA780148)	1
...		107 324	BRACKET, support pipe filler (Prior to KA780148)	1
...		107 343	GROMMET, rubber neck filler fuel (Prior to KA780148)	1
...		113 486	COVER, fuel tank (Prior to KA780148)	1
...		113 392	HOLD DOWN, fuel tank (Prior to KA780148)	1
...		113 294	SUPPORT, center mtg engine (Prior to KA780148)	1
...	12	147 601	CAP, tank screw-on w/vent	1
...	13	130 123	TANK, fuel 7.5gal (Eff w/KA780148 thru KG037343)	1
...	13	177 606	TANK, fuel 7.5gal (Eff w/KG037344 and on)	1
...	14	145 976	HOSE, nprn SAE .250 ID	1
...	15	084 173	CLAMP, hose .460-.545clp dia	2
...	16	066 113	FILTER, fuel inline .250 (included w/engine)	1
...	17		CLAMP, hose .460-.545clp dia (included w/engine)	2
...	18		HOSE, nprn SAE .250 ID (included w/engine) (order by ft)	1ft
...	19	135 627	ENGINE, gas elect start (Prior to KG037344) (consisting of)	1
...	19	178 479	ENGINE, gas elect start (Eff w/KG037344) (consisting of)	1
...		113 251	FITTING, pipe brs cap .375NPT (Prior to KF933389)	1
...		113 250	FITTING, pipe galv nipple L .375NPT (Prior to KF933389)	1
...	20	165 271	VALVE, oil drain (Eff w/KF933389)	1
...	21	107 297	MUFFLER, exhaust engine (Prior to KF926822)	1
...	21	164 353	MUFFLER, exhaust (Eff w/KF926822)	1
...	22	106 977	SOLENOID, 12VDC 20A	1
...	23	113 563	BRACKET, mtg solenoid (Prior to JK595850)	1
...	23	128 534	BRACKET, mtg solenoid(Eff w/JK595850)	1
...	24	128 869	LINKAGE KIT, (Prior to JJ404117)	1
...	24	128 431	SWIVEL, in-line .250-28 (Eff w/JJ404117)	1
...	25	128 533	LINK, throttle (Eff w/JJ404117)	1
...	26	064 646	SPRING, high speed	1
...		137 046	TUNE-UP & FILTER KIT, (consisting of)	1
...		064 617	ELEMENT, air cleaner	1
...		065 251	OIL FILTER	1
...		121 652	FILTER/CLAMPS, fuel	1
...		065 709	SPARK PLUG	2

Item No.	Dia. Mkgs.	Part No.	Description	Quantity
Figure 10-1. Main Assembly (Continued)				
... 27		107 308	HOLD DOWN, bat (Prior to KB113874)	1
... 27		146 697	HOLD DOWN, bat (Eff w/KB113874 thru KF959176)	1
... 27		165 631	HOLD DOWN, bat (Eff w/KF959177 and on)	1
...		010 493	BUSHING, snap-in nyl .625 ID x .875mtg hole (Prior to KA780148)	2
... 28		165 630	BOLT, J stl .250-20 x 6.125 (Eff w/KF959177)	1
... 29		168 385	LABEL, warning battery explosion	1
...		115 511	BRACKET, support cover (Prior to KF812089)	2
... 30		107 270	DOOR, access battery (Prior to KF959177)	1
... 30		175 887	DOOR, access battery (Eff w/KF959177)	1
... 31		088 577	CABLE, bat pos (Prior to KF959177) (consisting of)	1
... 31		167 731	CABLE, bat pos (Eff w/KF959177) (included w/engine) (consisting of)	1
...		071 970	COVER, cable bat post red	1
... 32	BAT	071 678	BATTERY, stor 12V (Prior to KF959177)	1
... 32	BAT	168 037	BATTERY, stor 12V (Eff w/KF959177)	1
...		114 923	BOOT, insulator term post red (Prior to KA780148)	1
...		135 571	BOOT, insulator term post red (Eff w/KA780148 thru KC220663)	1
...		108 081	TERMINAL PROTECTOR, battery post mtg	2
...		020 279	CLAMP, stl cushion .750 dia x .281mtg hole (Eff w/KA780148)	2
... 33		107 753	CABLE, bat neg (Prior to KA780148) (consisting of)	1
... 33		023 641	CABLE, bat neg (Eff w/KA780148 thru KE668694) (consisting of)	1
... 33		167 730	CABLE, bat neg (Eff w/KE668695) (consisting of)	1
...		071 971	COVER, cable bat post blk	1
... 34		Figure 10-2	GENERATOR	1
... 35		113 298	BASE, (Prior to KA780148)	1
... 35		132 195	BASE, (Eff w/KA780148 thru KB113873)	1
... 35		146 710	BASE, (Eff w/KB113874 and on)	1
... 36		134 792	LABEL, warning general precautionary engine etc	1
... 37		057 360	BLANK, snap-in nyl 1.375mtg hole	1
... 38	DC-Z	113 450	STABILIZER	1
... 39	AC-Z	113 451	REACTOR	1
... 40	SR1	142 503	RECTIFIER, si 1ph 300A	1
... 41		113 562	BRACKET, mtg resistor (Prior to JK559100)	1
... 41		126 072	BRACKET, mtg-resistor (Eff w/JK559100)	1
... 42		114 544	PANEL, front lower	1
... 43		Figure 10-3	PANEL, front w/components	1
... 44	CT1	105 370	TRANSFORMER, current	1
... 45		012 571	HOLDER, fuse mintr	1
... 46		*083 596	FUSE, mintr cer 12A 250V	1
... 47	R2,4	008 951	RESISTOR, WW adj 180W 12 ohm	2
... 48	R3,VR1	046 819	SUPPRESSOR	1
... 49	RC5	116 045	HOUSING PLUG & PINS, (consisting of)	1
...		113 633	CONNECTOR, rect univ 084 pin 20-14ga	6
... 50		109 994	LABEL, warning engine fuel can cause fire	1
... 51		013 367	LABEL, warning moving parts can cause serious injury	1
...		135 475	KIT, label (Prior to KF959177)	1
...		176 908	KIT, label (Eff w/KF959177)	1

+When ordering a component originally displaying a precautionary label, the label should also be ordered.

*Recommended Spare Parts.

++Optional Parts

BE SURE TO PROVIDE MODEL AND SERIAL NUMBER WHEN ORDERING REPLACEMENT PARTS.

Item No.	Dia. Mkgs.	Part No.	Description	Quantity
----------	------------	----------	-------------	----------

Figure 10-2. Generator (Figure 10-1 Item 34)

...	1	013 367	.. LABEL, warning fan	2
...	2	115 500	.. LABEL, engine maintenance Onan (Prior to KA780148)	1
...	2	134 092	.. LABEL, engine maintenance Onan P218 (Eff w/KA780148 thru KF959176)	1
...	2	176 891	.. LABEL, engine maintenance Onan P218 (Eff w/KF959177 and on)	1
...	3	+113 410	.. GUARD, fan gen	1
...	4	153 297	.. ENDBELL, gen (consisting of)	1
...	5	143 220	.. O-RING, 2.859 ID x .139CS	1
...	6	165 756	.. STATOR, gen 60Hz (Prior to KD438829)	1
...	6	162 138	.. STATOR, gen 60Hz (Eff w/KD438829)	1
...	6	165 755	.. STATOR, gen 50Hz (Prior to KD438829)	1
...	6	162 141	.. STATOR, gen 50Hz (Eff w/KD438829)	1
...	7	017 702	.. ADAPTER, engine	1
...	003 455	.. KEY, woodruff .250 x .750 SAE No. 91 (part of engine) (Prior to KA780148)	1	
...	8	021 934	.. ADAPTER, fan rotor (Prior to KA780148)	1
...	8	134 981	.. ADAPTER, fan rotor (Eff w/KA780148)	1
...	9	008 917	.. WASHER, flat stl .343 ID x 2 (part of engine)	1
...	10	049 286	.. ROTOR ASSEMBLY, gen (consisting of)	1
...	11	017 624	.. FAN, rotor gen	1
...	12	053 390	.. BEARING, ball rdl sgl row 1.37	1
...	13	024 617	.. RING, retaining ext 1.272 shaft	1
...		602 348	.. KEY, stl .250 x .250 x .750	1
...	14	SR2 035 704	.. RECTIFIER, integ 40A 800V	1
...	15	007 250	.. BRACKET, mtg brushholder	1
...	16	047 878	.. BAR, retaining brushholder	1
...	17	161 306	.. CAP, brushholder	3
...	18	*126 984	.. BRUSH w/SPRING	3
...	19	005 614	.. HOLDER, brush	3

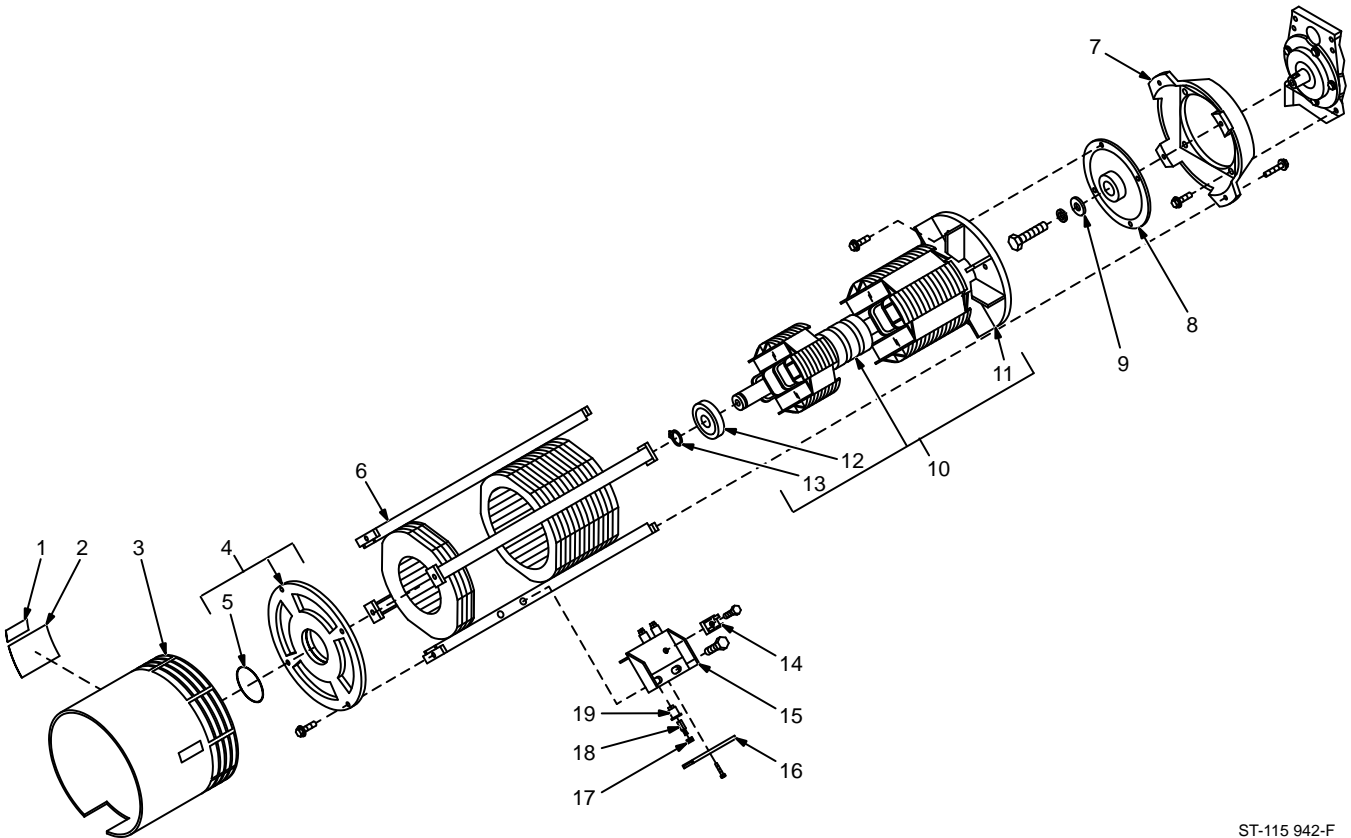

Figure 10-2. Generator

ST-115 942-F

+When ordering a component originally displaying a precautionary label, the label should also be ordered.

*Recommended Spare Parts.

BE SURE TO PROVIDE MODEL AND SERIAL NUMBER WHEN ORDERING REPLACEMENT PARTS.

Item No.	Dia. Mkgs.	Part No.	Description	Quantity
----------	------------	----------	-------------	----------

Figure 10-3. Panel, Front w/Components (Figure 10-1 Item 43)

...	1	RC1,2	...	604 176	...	RECEPTACLE, str dx grd 2P3W 15A 125V (Prior to KE629034)	2
.....			073 690	...	PLUG, str grd armd 2P3W 15A 125V P&S 5266 DF		
...	1	RC1,2	...	167 657	...	RECEPTACLE, str dx grd 2P3W 15A 125V (Eff w/KE629034)	2
...	2	CB1,2	...	115 427	...	CIRCUIT BREAKER, man reset 1P 25A 250VAC (Prior to KE629034)	..	2
...	2	CB5,7	...	168 057	...	CIRCUIT BREAKER, man reset 1P 20A 250VAC (Eff w/KE629034)	2
...	3		113 315	...	PANEL, front (Prior to JK713332)	1
...	3		130 352	...	PANEL, front (Eff w/JK713332 thru KB133271)	1
...	3		143 383	...	PANEL, front (Eff w/KB133272 thru KF790319)	1
...	3		170 554	...	PANEL, front (Eff w/KF790320 and on)	1
...	4	S5	005 563	...	SWITCH, selector (Figure 10-4)	1
...	5	R1	081 712	...	RHEOSTAT, WW 100W 30 ohm	1
...	6	S4	..	++011 609	...	SWITCH, tgl SPDT 15A 125VAC (Prior to JK713332)	1
...	6	S4	..	++011 611	...	SWITCH, tgl DPDT 15A 125V (Eff w/JK713332)	1
...	7	RC7	035 523	...	CONNECTOR, circ MS/MET 5skt sz 16S rect MS-3102A-16S-8S Amphenol (Prior to JK713332)	1

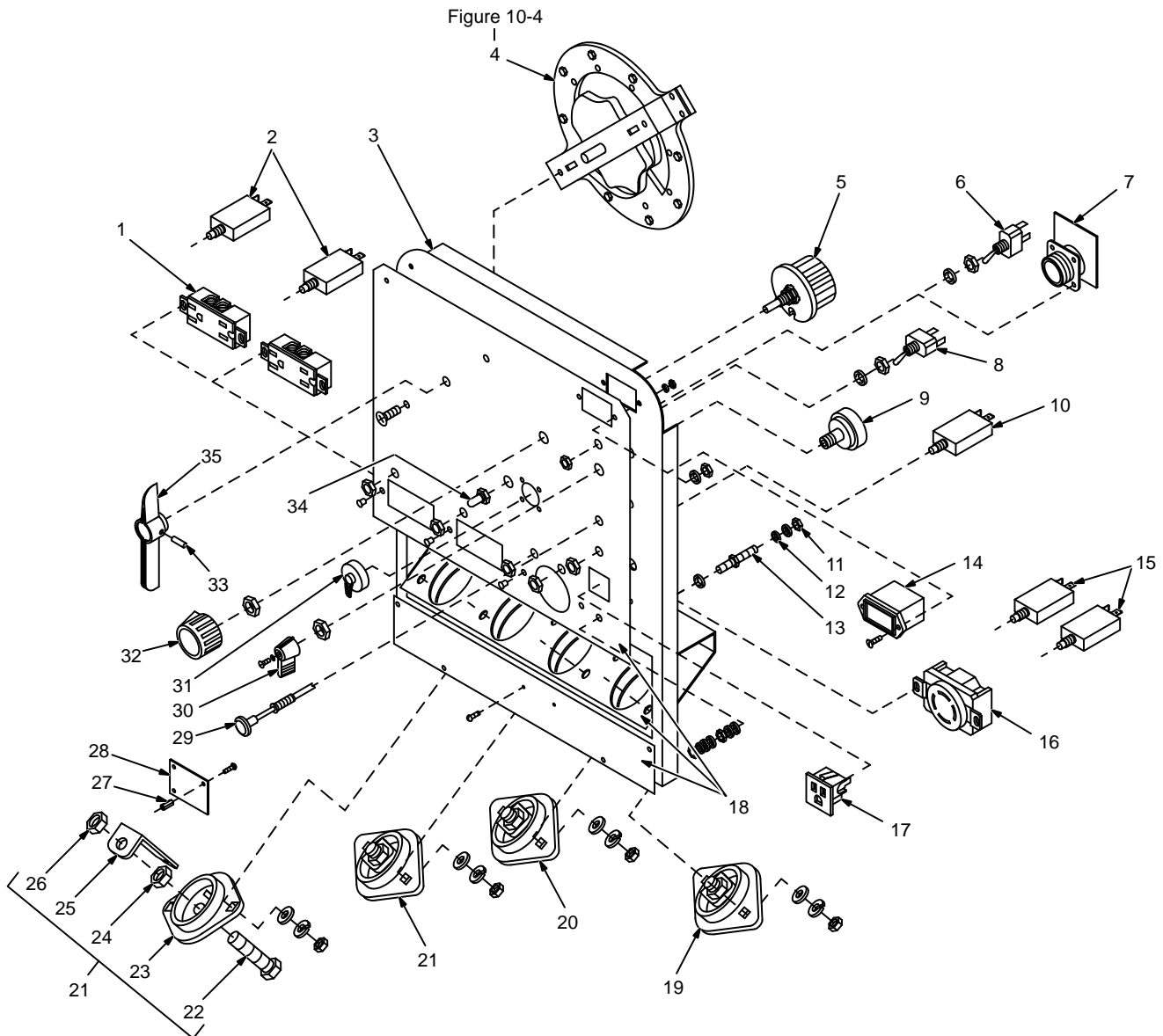

Figure 10-3. Panel, Front w/Components

ST-115 943-J

Item No.	Dia. Mkgs.	Part No.	Description	Quantity
Figure 10-3. Panel, Front w/Components (Figure 10-1 Item 43) (Continued)				
.....		039 273	CONNECTOR, circ MS/MET 5 pin sz 16S MS-3106A-16S-8P Amphenol	
.....		039 685	CONNECTOR, circ MS/MET clamp str rlf sz 16-16S AN-3057-8 Amphenol	
... 7	RC7	++086 022	CONNECTOR, circ MS/MET 14skt sz 20 MS-3102A-20-27S (Eff w/JK713332 thru KD344393)	1
.....		109 766	CONNECTOR, circ 14 pin MS sz 20 Amphenol 97-4106A-20-27P	
.....		109 770	CONNECTOR, circ MS pin push-in 16-22ga	
.....		039 734	CONNECTOR, circ MS/MET clamp str rlf sz 20-22S Amphenol AN-3057-12	
... 7	PC5	156 025	CIRCUIT CARD, connector/receptacle (Eff w/KD344394)	1
.....	C7-11	++097 749	CAPACITOR, (Eff w/JK713332 thru KD344393)	5
... 8	S1	011 622	SWITCH, tgl 3PDT 15A 125VAC (Prior to JK713332)	1
... 8	S1	011 611	SWITCH, tgl DPDT 15A 125V (Eff w/JK713332)	1
... 9	S2	172 070	SWITCH, ignition	1
... 10	CB3	083 432	CIRCUIT BREAKER, man reset 1P 10A 250V	1
... 11		601 836	NUT, brs hex jam hvy .250-20	3
... 12		010 915	WASHER, flat brs .250 ID x .625 OD	2
... 13		083 030	STUD, brs grd .250-20 x 1.750	1
... 14		◆042 130	METER KIT, (Prior to KD548030) (consisting of)	1
.....	HM	032 936	METER, hour	1
... 14		145 247	METER, hour 12-24VDC (Eff w/KD548030)	1
... 15	CB1,2	144 474	CIRCUIT BREAKER, man reset 1P 25A 250VAC (Eff w/KE629034)	2
... 16	RC3	604 103	RECEPTACLE, str dx grd 2P3W 15A 250V (Prior to JH300534)	1
.....		025 234	PLUG, str grd 2P3W 15A 250V Leviton 5443	
... 16	RC3	129 067	RECEPTACLE, twlk grd 3P4W 30A 125/250V (Eff w/JH300534)	1
.....		088 898	PLUG, twlk grd 3P4W 30A 125/250V	
... 17	RC4	034 952	RECEPTACLE, str 3P3W 15A 125V	1
.....		073 690	PLUG, str grd armd 2P3W 15A 125V P&S 5266 DF	
... 18			NAMEPLATE, (order by model & serial number)	1
... 19	POS	039 047	TERMINAL, pwr output red (consisting of)	1
... 20	NEG	039 046	TERMINAL, pwr output black (consisting of)	1
... 21		099 255	TERMINAL, pwr output neutral (consisting of)	2
... 22		601 976	SCREW, cap stl hex hd .500-13 x 1.500	1
... 23		039 049	TERMINAL BOARD, red	1
... 23		039 045	TERMINAL BOARD, black	1
... 23		039 040	TERMINAL BOARD, neutral	1
... 24		601 880	NUT, stl hex jam .500-13	1
... 25		039 044	BUS BAR, term bd	1
... 26		601 879	NUT, stl hex full fnsh .500-13	1
... 27		073 756	STAND-OFF, No. 6-32 x .625 lg x .250 hex (Eff w/KD344394)	2
.....		153 501	HOUSING PLUG & SOCKETS, (Eff w/KD344394) (consisting of)	1
.....		147 995	CONNECTOR, rect univ 039skt 22-18	6
... 28	C6	115 109	CAPACITOR, (Prior to KD344394)	1
... 28	PC4	148 021	CIRCUIT CARD, filter HF (Eff w/KD344394)	1
... 29		111 584	CONTROL, push-pull (Prior to JH283238)	1
... 29		116 813	CONTROL, push-pull (Eff w/JH283238)	1
... 30		119 014	LEVER, switch	1
... 31		++108 864	CAP, dust connector 9760-16 (Prior to JK713332)	1
... 31		++109 993	CAP, dust connector 9760-20 (Eff w/JK713332)	1
... 32		097 924	KNOB, pointer	1
... 33		010 647	PIN, spring cs .156 x 1.250	1
... 34		++021 385	BOOT, tgl switch lever	1
... 35		115 493	HANDLE, switch range	1

++Part of Remote Control Option

◆Effective w/KD548030 Optional Meter Kit became Standard Equipment.

BE SURE TO PROVIDE MODEL AND SERIAL NUMBER WHEN ORDERING REPLACEMENT PARTS.

Item No.	Part No.	Description	Quantity
005 563 Figure 10-4. Switch, Selector (Figure 10-3 Item 4)			
... 1	005 562	.. BRACKET, mtg-switch	1
... 2	005 561	.. SHAFT, rotor	1
... 3	005 564	.. INSULATOR, screw switch	1
... 4	605 276	.. SCREW, cap stl hex hd .250-20 x 1.250	1
... 5	005 559	.. CONTACT BOARD, movable switch	1
... 6	005 560	.. CONTACT, switch movable	1
... 7	008 485	.. SPACER, contact switch	1
... 8	005 566	.. CONTACT BOARD, stationary switch	1
... 9	011 644	.. CONTACT, stationary switch	7
... 10	052 405	.. SPRING, pressure contact switch	1
... 11	052 404	.. CONTACT, movable switch	1
... 12	005 557	.. BUS BAR, switch range	1
... 13	005 558	.. SPRING, selector switch	1

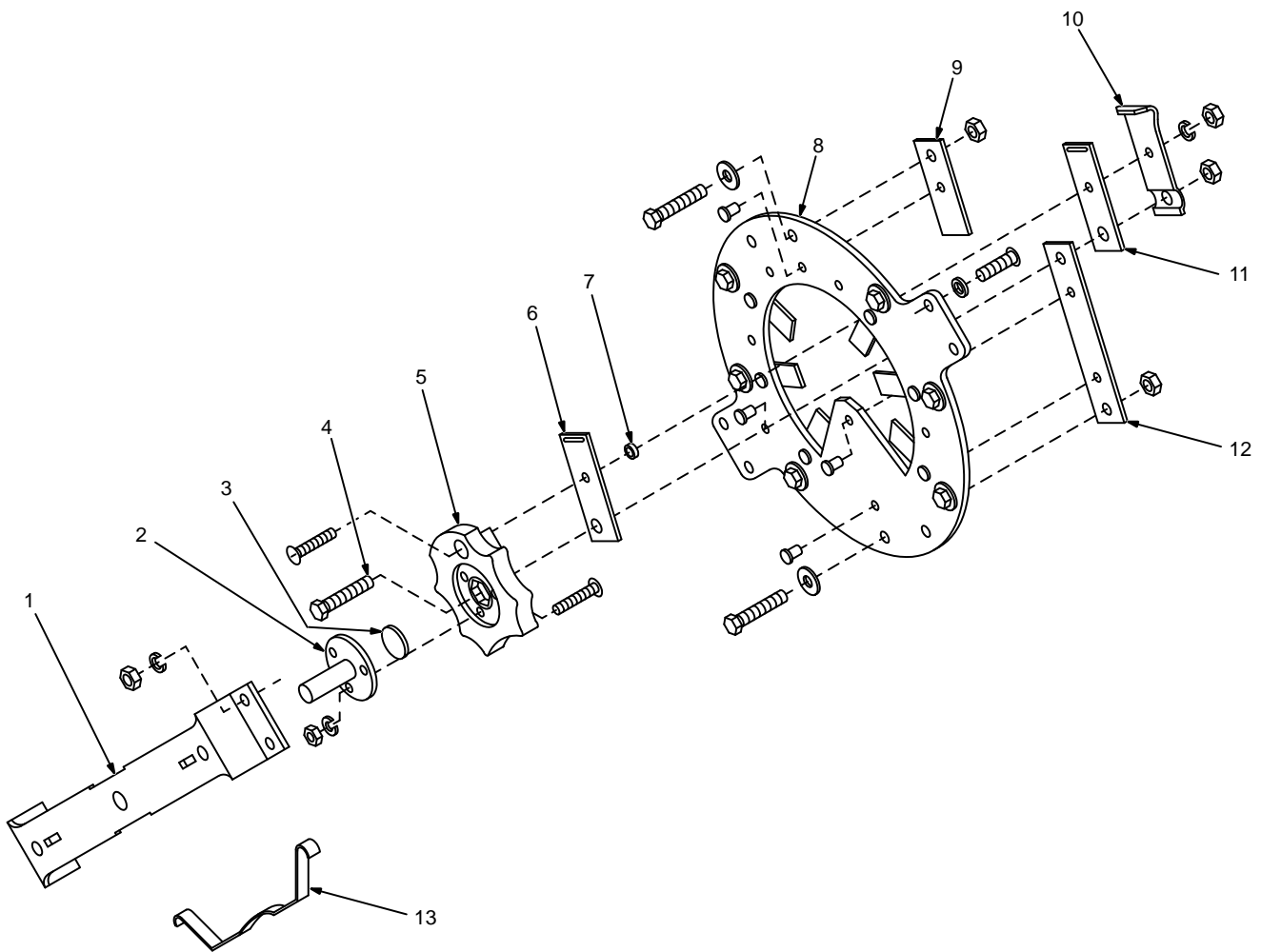

Figure 10-4. Switch, Selector

ST-097 264-A

BE SURE TO PROVIDE MODEL AND SERIAL NUMBER WHEN ORDERING REPLACEMENT PARTS.

Item No.	Dia. Mkgs.	Part No.	Description	Quantity
----------	------------	----------	-------------	----------

Figure 10-5. Control Panel, w/Components (Figure 10-1 Item 2)

...	1	1T	038 601	BLOCK, term 30A 9P (Prior to JK713332)	1
...	1	1T	130 648	BLOCK, term 30A 10P (Eff w/JK713332)	1
...	2		113 682	BRACKET, mtg components (Prior to JK713332)	1
...	2		130 649	BRACKET, mtg components (Eff w/JK713332)	1
...	3		083 147	GROMMET, scr No.8/10	4
...	4	PC2	049 404	CIRCUIT CARD, regulator 115V (Prior to KE604176)	1
...	4	PC2	160 888	CIRCUIT CARD, voltage regulator (Eff w/KE604176) (Figure 10-7)	1
...		PLG1	168 071	CONNECTOR & SOCKETS, (Eff w/KE604176) (consisting of)	1
...			114 066	CONNECTOR, rect skt 20-14ga	9
...	5	CR4	113 247	RELAY, encl 12VDC DPDT	1
...	6	CR3	044 588	RELAY, encl 12VDC 3PDT	1
...	7	CR2	173 069	RELAY, encl 12VDC SPDT	1
...	8	CB4	045 061	CIRCUIT BREAKER, auto reset 24VDC 7A	1
...	9	PC1	113 492	CIRCUIT CARD, weld/idle (Prior to JH300534)	1
...	9	PC1	142 725	MODULE, pull to weld/power delay (Eff w/JH300534)	1
...	10	D4	059 389	DIODE, rect 3A 1000V SP (Prior to JH300534)	1
...	10	D4,5	059 389	DIODE, rect 3A 1000V SP (Eff w/JH300534)	2
...	11	T1	116 083	TRANSFORMER, control (Prior to KE604176)	1
...	11	T1	167 404	TRANSFORMER, control (Eff w/KE604176)	1
...	12		038 620	LINK, jumper term blk 30A	1
...		D6	117 566	DIODE, rect 6A 600V	1

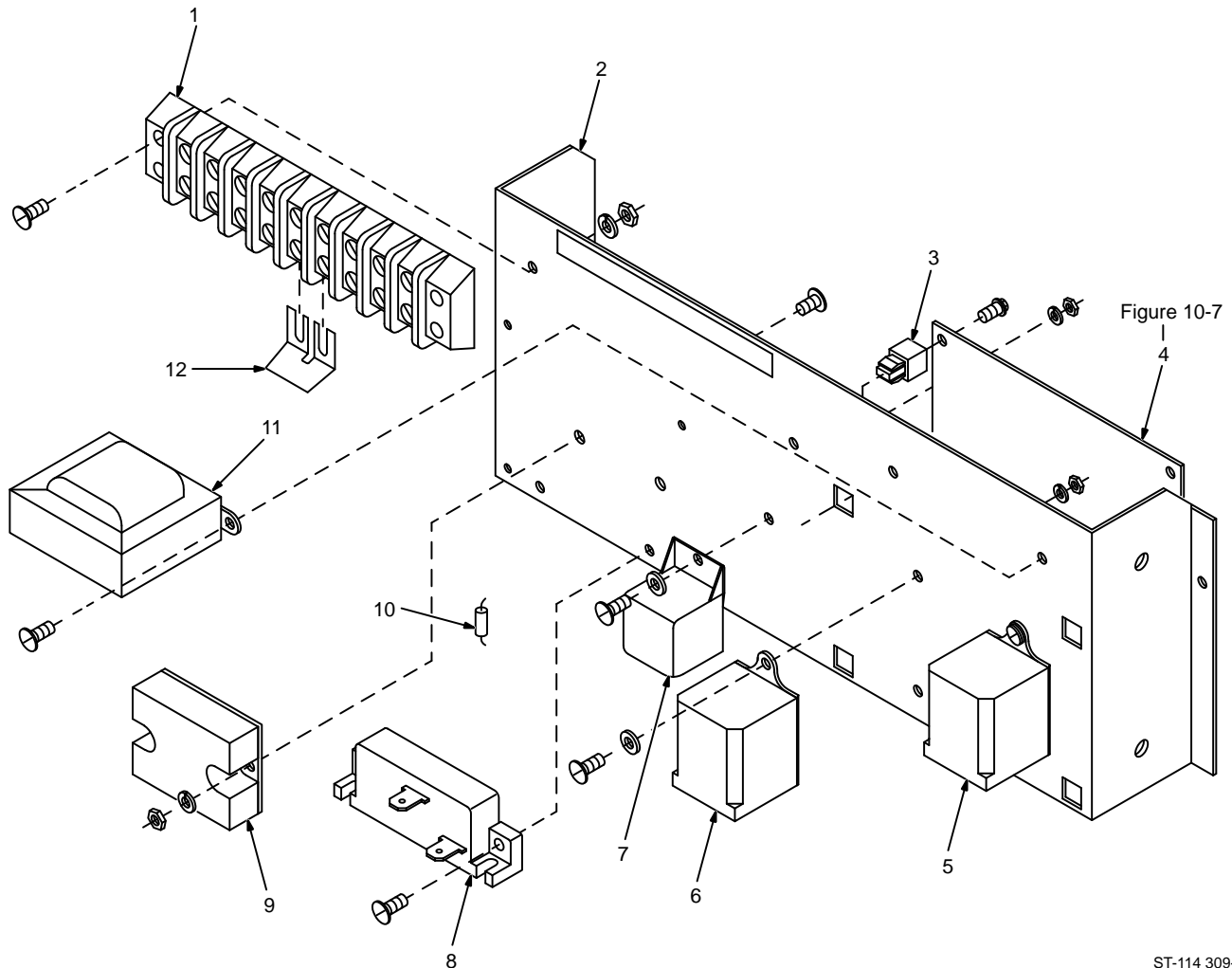

Figure 10-5. Control Panel, w/Components

ST-114 309-B

BE SURE TO PROVIDE MODEL AND SERIAL NUMBER WHEN ORDERING REPLACEMENT PARTS.

Item No.	Dia. Mkgs.	Part No.	Description	Quantity
		+042 132	Figure 10-6. Remote Control, Option (Figure 10-1 Item 1)	
		+042 383		
...	1	PC3	136 246 ... CIRCUIT CARD ASSEMBLY, remote control	1
...	2		110 375 ... STAND-OFF SUPPORT, PC card	4
...	3		116 086 ... BRACKET, mtg remote control (Prior to JK563388)	1
...	3		125 873 ... BRACKET, mtg remote control (Eff w/JK563388)	1
...	4	CR5	052 603 ... RELAY, encl 110VDC DPDT	1
...	5		007 532 ... CLAMP, capacitor 1.000dia	1
...	6	C5	059 887 ... CAPACITOR, polyp met film 10uf 220V	1
...	7	2T	116 005 ... BLOCK, term 10A 7P	1
...	8		108 023 ... LINK, jumper term blk 10A	4
...	9	PLG6	115 091 ... HOUSING PLUG & SOCKETS, (consisting of)	1
.....			113 746 TERMINAL, female 1skt 18-24W	10

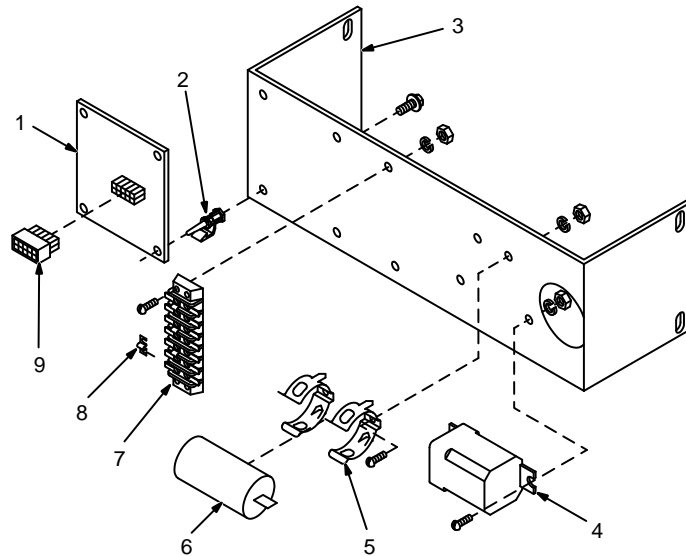
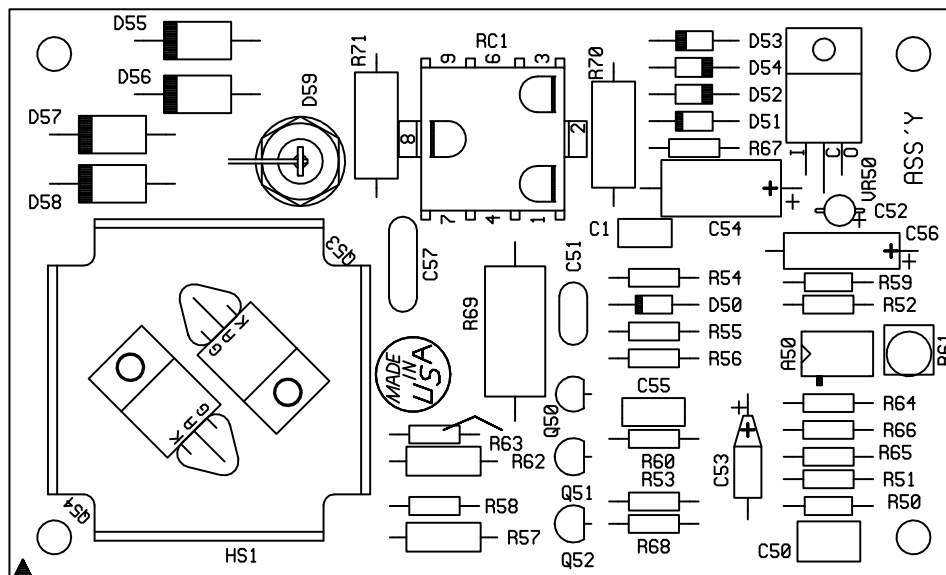

Figure 10-6. Remote Control, Option

SB-116 028

+See Figure 10-3 for additional parts not listed
BE SURE TO PROVIDE MODEL AND SERIAL NUMBER WHEN ORDERING REPLACEMENT PARTS.

Dia. Mkgs.	Part No.	Description	Quantity
PC2	160 888	Figure 10-7. Circuit Card, Voltage Regulator (Figure 10-5 Item 4)	
..... A50	165 411	IC, linear 2904	1
..... C1	003 530	CAPACITOR, cer mono 1uf 50VDC	1
..... C50	119 199	CAPACITOR, polye met film 1uf 50V	1
..... C51	053 992	CAPACITOR, cer disc .001uf 1000VDC	1
..... C52	000 348	CAPACITOR, tantlm .47uf 35V	1
..... C53	005 023	CAPACITOR, tantlm 2.2uf 20V	1
..... C54	072 935	CAPACITOR, elctlt 33uf 35VDC	1
..... C55	137 463	CAPACITOR, polye met film .22uf 100VDC	1
..... C56	072 113	CAPACITOR, tantlm 4.7uf 35VDC	1
..... C57	028 292	CAPACITOR, cer disc .005uf 1000VDC	1
..... D50	028 351	DIODE, sig 200mA 75V SP	1
..... D51	049 641	DIODE, zener 27V 1W	1
..... D52-54	026 202	DIODE, rect 1A 400V SP	3
..... D55-58	070 250	DIODE, rect 3A 600V	4
..... D59	030 529	DIODE, rect 22A 600V RP	1
..... Q50	039 355	TRANSISTOR, ujt 15mA 40V	1
..... Q51,52	037 200	TRANSISTOR, NPN 200mA 40V	2
..... Q53,54	049 642	THYRISTOR, SCR 8A 600V	2
..... R50	094 447	RESISTOR, MF .25W 681K ohm	1
..... R51	044 789	RESISTOR, MF .25W 100K ohm	1
..... R52	035 829	RESISTOR, MF .25W 1.5K ohm	1
..... R53,54,65	072 559	RESISTOR, MF .25W 22.1K ohm	3
..... R55	115 530	RESISTOR, MF .25W 2.67K ohm	1
..... R56,64	000 885	RESISTOR, MF .25W 10K ohm	2
..... R57,62	028 285	RESISTOR, C .5W 100 ohm	2
..... R58,63	035 823	RESISTOR, MF .25W 100 ohm	2
..... R59	072 559	RESISTOR, MF .25W 22.1K ohm	1
..... R60	074 026	RESISTOR, C .25W 150 ohm	1
..... R61	138 301	POTENTIOMETER, cermet trmr 1/T .5W 25K ohm	1
..... R66	093 030	RESISTOR, MF .25W 15K ohm	1
..... R67	093 032	RESISTOR, MF .25W 26.7K ohm	1
..... R68	108 437	RESISTOR, MF .25W 4.75K ohm	1
..... R69	049 439	RESISTOR, C 2W 47K ohm	1
..... R70	074 099	RESISTOR, C 1W 150 ohm	1
..... R71	030 707	RESISTOR, C 1W 47 ohm	1
..... RC1	160 892	CONNECTOR, rect 9 pin 3 row rcpt	1
..... VR50	083 772	IC, rgltr 7815	1



SA-160 889

Figure 10-7. Circuit Card, Voltage Regulator PC2

BE SURE TO PROVIDE MODEL AND SERIAL NUMBER WHEN ORDERING REPLACEMENT PARTS.

