



TM-353E January 2001

Eff. w/Serial Number JJ339876

Processes



TIG (GTAW) Welding



Stick (SMAW) Welding

Description



Arc Welding Power Source

CE

Syncrowave[®] 250

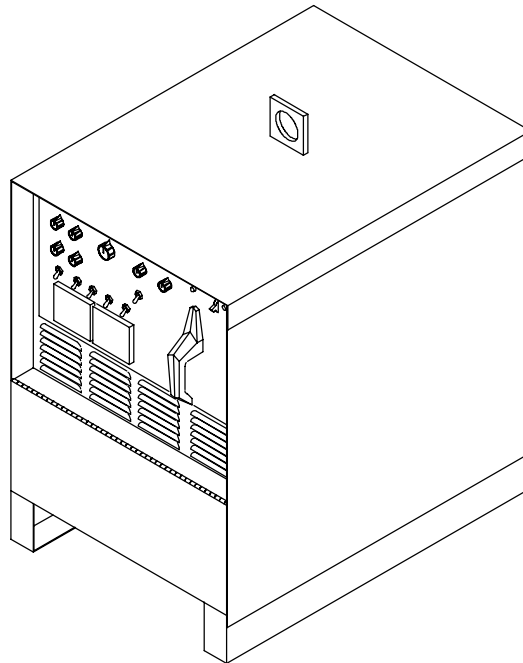

60 Hz, 50 Hz



Visit our website at
www.MillerWelds.com

TECHNICAL MANUAL

TABLE OF CONTENTS

1. Safety Precautions – Read Before Using	1
1.1 Symbol Usage	1
1.2 Servicing Hazards	1
1.3 EMF Information	2
SECTION 2 – DEFINITIONS	3
2-1. Warning Label Definitions	3
2-2. Rating Label For CE Products	4
2-3. Symbols And Definitions	5
SECTION 3 – INSTALLATION	6
3-1. Specifications	6
3-2. Volt-Ampere Curves	6
3-3. Duty Cycle And Overheating	7
3-4. Selecting A Location	8
3-5. Dimensions And Weights	8
3-6. Tipping	9
3-7. Weld Output Terminals And Selecting Cable Sizes	9
3-8. Remote 14 Receptacle	10
3-9. 115 Volts AC Duplex Receptacle And Shielding Gas Connections	10
3-10. Electrical Service Guide	11
3-11. Placing Jumper Links And Connecting Input Power	12
SECTION 4 – OPERATION	13
4-1. Controls	13
4-2. Output Selector Switch	14
4-3. Meters	14
4-4. Crater Time Controls	15
4-5. Spot Time Controls	15
4-6. AC Balance Control	16
4-7. Amperage Adjustment Controls	17
4-8. Output (Contactor) Control Switch	17
4-9. Arc Controls	18
4-10. Postflow Time Control	18
4-11. High Frequency Controls	19
4-12. Preflow Time Control (Optional)	19
SECTION 5 – THEORY OF OPERATION	20
SECTION 6 – TROUBLESHOOTING	22
6-1. Troubleshooting Table	22
6-2. Troubleshooting Circuit Diagram For Welding Power Source	26
6-3. Waveforms For Section 6-2	28
6-4. Control Board PC1 Testing Information (Use With Section 6-5)	30
6-5. Control Board PC1 Test Point Values	31
6-6. Remote Board PC2 Testing Information (Use With Section 6-7)	33
6-7. Remote 14 Filter Board PC2 Test Point Values (Use With Section 6-2 And Section 6-6)	34
6-8. Meter Calibration	35
6-9. Input Voltage Labels And Connections	36
SECTION 7 – MAINTENANCE	37
7-1. Routine Maintenance	37
7-2. Circuit Breaker CB1	37
7-3. Fuses F1 And F2	38
7-4. Adjusting Spark Gaps	38
SECTION 8 – HIGH FREQUENCY (HF)	39
8-1. Welding Processes Using HF	39
8-2. Sources Of HF Radiation From Incorrect Installation	39
8-3. Correct Installation	40
SECTION 9 – ELECTRICAL DIAGRAMS	41
SECTION 10 – PARTS LIST	68

Declaration of Conformity For European Community (CE) Products

NOTE 

This information is provided for units with CE certification (see rating label on unit.)

Manufacturer's Name: **Miller Electric Mfg. Co.**

Manufacturer's Address: 1635 W. Spencer Street
Appleton, WI 54914 USA

Declares that the product: **Syncrowave® 250**

conforms to the following Directives and Standards:

Directives

Low Voltage Directive: 73/23/EEC

Machinery Directives: 89/392/EEC, 91/368/EEC, 93/C 133/04, 93/68/EEC

Electromagnetic Capability Directives: 89/336, 92/31/EEC

Standards

Safety Requirements for Arc Welding Equipment part 1: EN 60974-1: 1990

*Arc Welding Equipment Part 1: Welding Power Sources: IEC 974-1
(April 1995 – Draft revision)*

Degrees of Protection provided by Enclosures (IP code): IEC 529: 1989

*Insulation coordination for equipment within low-voltage systems:
Part 1: Principles, requirements and tests: IEC 664-1: 1992*

*Electromagnetic compatibility (EMC) Product standard for arc welding equipment:
EN50199: August 1995*

European Contact: Mr. Luigi Vacchini, Managing Director
MILLER Europe S.P.A.
Via Privata Iseo
20098 San Giuliano
Milanese, Italy

Telephone: 39(02)98290-1
Fax: 39(02)98281-552

SECTION 1 – SAFETY PRECAUTIONS FOR SERVICING

safety_stm1 4/95

1-1. Symbol Usage

	<p>Means Warning! Watch Out! There are possible hazards with this procedure! The possible hazards are shown in the adjoining symbols.</p>	<p>▲ Marks a special safety message.</p>	<p>☞ Means NOTE; not safety related.</p>
	<p>This group of symbols means Warning! Watch Out! possible ELECTRIC SHOCK, MOVING PARTS, and HOT PARTS hazards. Consult symbols and related instructions below for necessary actions to avoid the hazards.</p>		

1-2. Servicing Hazards





WARNING

The symbols shown below are used throughout this manual to call attention to and identify possible hazards. When you see the symbol, watch out, and follow the related instructions to avoid the hazard.

Only qualified persons should service, test, maintain, and repair this unit.

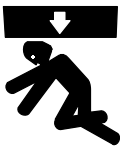
During servicing, keep everybody, especially children, away.

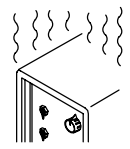
	<p>ELECTRIC SHOCK can kill.</p> <ol style="list-style-type: none"> Do not touch live electrical parts. Stop engine or turn OFF welding power source and wire feeder, and disconnect and lockout input power using line disconnect switch, circuit breakers, or by removing plug from receptacle before servicing unless the procedure specifically requires an energized unit. 		<p>HOT PARTS can cause severe burns.</p> <ol style="list-style-type: none"> Do not touch hot parts bare handed. Allow cooling period before servicing welding gun or torch.
	<ol style="list-style-type: none"> Insulate yourself from ground by standing or working on dry insulating mats big enough to prevent contact with the ground. Do not leave live unit unattended. When testing a live unit, use the one-hand method. Do not put both hands inside unit. Keep one hand free. Disconnect input power conductors from deenergized supply line BEFORE moving a welding power source. <p>SIGNIFICANT DC VOLTAGE exists after removal of input power on inverters.</p> <ol style="list-style-type: none"> Turn Off inverter, disconnect input power, and discharge input capacitors according to instructions in Maintenance Section before touching any parts. 		<p>EXPLODING PARTS can cause injury.</p> <ol style="list-style-type: none"> Failed parts can explode or cause other parts to explode when power is applied to inverters. Always wear a face shield and long sleeves when servicing inverters.
	<p>STATIC ELECTRICITY can damage parts on circuit boards.</p> <ol style="list-style-type: none"> Put on grounded wrist strap BEFORE handling boards or parts. Use proper static-proof bags to store, move, or ship PC boards. 		<p>ELECTRIC SHOCK HAZARD from incorrect use of test equipment.</p> <ol style="list-style-type: none"> Turn Off welding power source and wire feeder or stop engine before making or changing meter lead connections. At least one meter lead should be a self-retaining spring clip such as an alligator clamp. Read instructions for test equipment.
	<p>FIRE OR EXPLOSION can result from placing unit on, over, or near combustible surfaces.</p> <ol style="list-style-type: none"> Do not place unit on, over, or near combustible surfaces. Do not service unit near flammables. 		<p>HIGH-FREQUENCY RADIATION can interfere with radio navigation, safety services, computers, and communications equipment.</p> <ol style="list-style-type: none"> Have only qualified persons familiar with electronic equipment perform this installation. The user is responsible for having a qualified electrician promptly correct any interference problem resulting from the installation. If notified by the FCC about interference, stop using the equipment at once. Have the installation regularly checked and maintained. Keep high-frequency source doors and panels tightly shut, keep spark gaps at correct setting, and use grounding and shielding to minimize the possibility of interference.
	<p>FLYING PIECES OF METAL or DIRT can injure eyes.</p> <ol style="list-style-type: none"> Wear safety glasses with side shields or face shield during servicing. Be careful not to short metal tools, parts, or wires together during testing and servicing. 		

	<p>FALLING EQUIPMENT can cause serious personal injury and equipment damage.</p> <ol style="list-style-type: none"> 1. Use lifting eye to lift unit only, NOT running gear, gas cylinders, or any other accessories. 2. Use equipment of adequate capacity to lift unit. 		<p>MOVING PARTS can cause injury.</p> <ol style="list-style-type: none"> 1. Keep away from moving parts. 2. Keep away from pinch points such as drive rolls.
	<p>MAGNETIC FIELDS FROM HIGH CURRENTS can affect pacemaker operation.</p> <ol style="list-style-type: none"> 1. Pacemaker wearers keep away from servicing areas until consulting your doctor. 		<p>OVERUSE can cause OVERHEATED EQUIPMENT.</p> <ol style="list-style-type: none"> 1. Allow cooling period. 2. Reduce current or reduce duty cycle before starting to weld again. 3. Follow rated duty cycle.
	<p>MOVING PARTS can cause injury.</p> <ol style="list-style-type: none"> 1. Keep away from moving parts such as fans. 2. Keep all doors, panels, covers, and guards closed and securely in place. 		<p>READ INSTRUCTIONS.</p> <ol style="list-style-type: none"> 1. Use MILLER Testing Booklet (Part No. 150 853) when servicing this unit. 2. Consult the Owner's Manual for welding safety precautions. 3. Use only genuine MILLER replacement parts.

1-3. EMF Information

<p>Considerations About Welding And The Effects Of Low Frequency Electric And Magnetic Fields</p> <p>The following is a quotation from the General Conclusions Section of the U.S. Congress, Office of Technology Assessment, <i>Biological Effects of Power Frequency Electric & Magnetic Fields – Background Paper</i>, OTA-BP-E-53 (Washington, DC: U.S. Government Printing Office, May 1989): “. . . there is now a very large volume of scientific findings based on experiments at the cellular level and from studies with animals and people which clearly establish that low frequency magnetic fields can interact with, and produce changes in, biological systems. While most of this work is of very high quality, the results are complex. Current scientific understanding does not yet allow us to interpret the evidence in a single coherent framework. Even more frustrating, it does not yet allow us to draw definite conclusions about questions of possible risk or to offer clear science-based advice on strategies to minimize or avoid potential risks.”</p>	<p>To reduce magnetic fields in the workplace, use the following procedures:</p> <ol style="list-style-type: none"> 1. Keep cables close together by twisting or taping them. 2. Arrange cables to one side and away from the operator. 3. Do not coil or drape cables around the body. 4. Keep welding power source and cables as far away as practical. 5. Connect work clamp to workpiece as close to the weld as possible. <p>About Pacemakers:</p> <p>The above procedures are also recommended for pacemaker wearers. Consult your doctor for complete information.</p>
--	---

SECTION 2 – DEFINITIONS

2-1. Warning Label Definitions



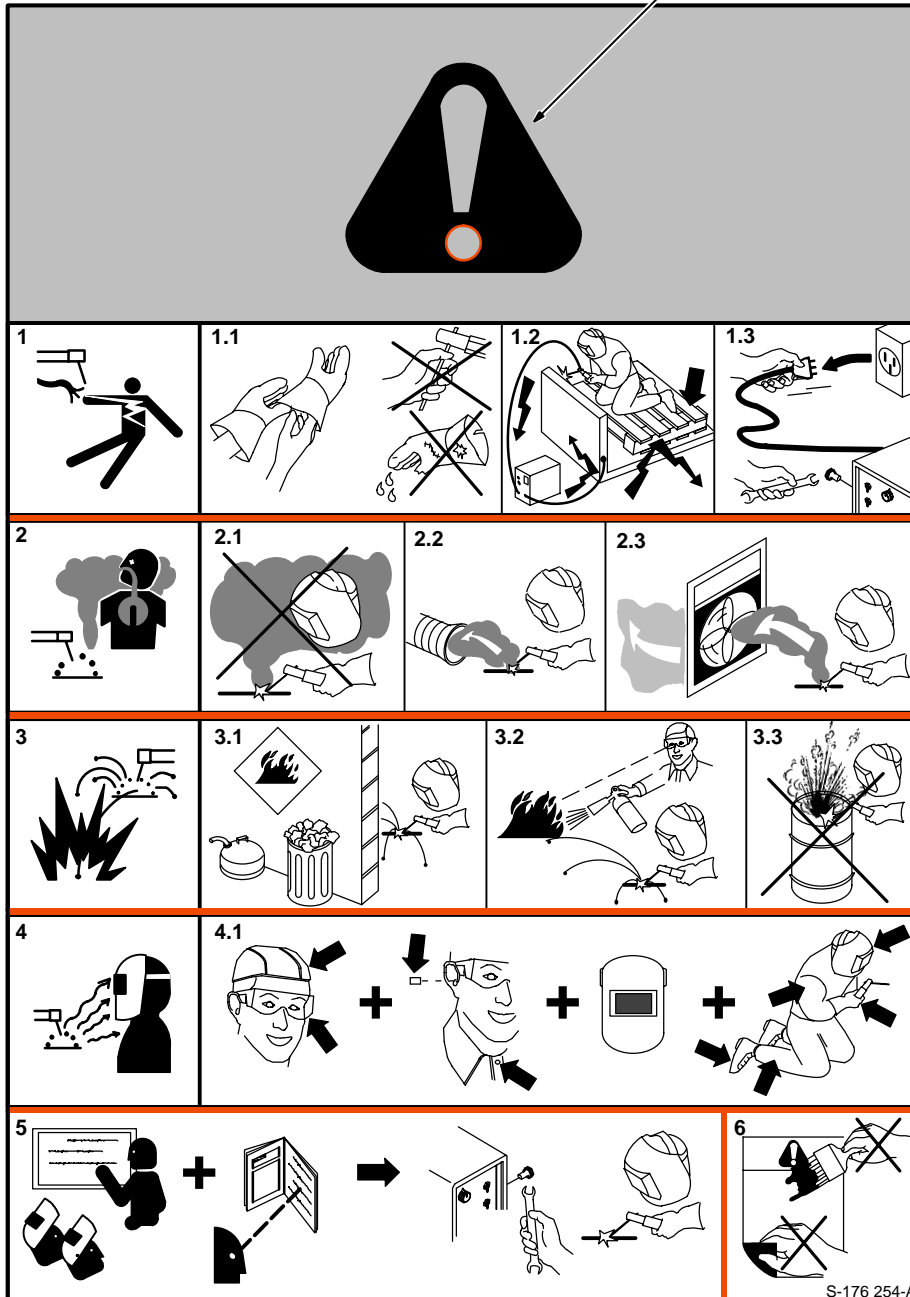



Warning! Watch Out! There are possible hazards as shown by the symbols.



- 1 Electric shock from welding electrode or wiring can kill.
- 1.1 Wear dry insulating gloves. Do not touch electrode with bare hand. Do not wear wet or damaged gloves.
- 1.2 Protect yourself from electric shock by insulating yourself from work and ground.
- 1.3 Disconnect input plug or power before working on machine.
- 2 Breathing welding fumes can be hazardous to your health.
- 2.1 Keep your head out of the fumes.
- 2.2 Use forced ventilation or local exhaust to remove the fumes.
- 2.3 Use ventilating fan to remove fumes.
- 3 Welding sparks can cause explosion or fire.
- 3.1 Keep flammables away from welding. Don't weld near flammables.
- 3.2 Welding sparks can cause fires. Have a fire extinguisher nearby and have a watch person ready to use it.
- 3.3 Do not weld on drums or any closed containers.
- 4 Arc rays can burn eyes and injure skin.
- 4.1 Wear hat and safety glasses. Use ear protection and button shirt collar. Use welding helmet with correct shade of filter. Wear complete body protection.
- 5 Become trained and read the instructions before working on the machine or welding.
- 6 Do not remove or paint over (cover) the label.

S-176 254-A































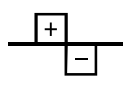

2-2. Rating Label For CE Products

		ISO/IEC 974-1			
		7A/10.2V		310A/22.4V	
		X	25%	60%	100%
	U ₀ = 80V	I ₂	310A	200A	155A
		U ₂	22.4V	18V	16.2V
		5A/20.2V		310A/32.4V	
		X	25%	60%	100%
	U ₀ = 80V	I ₂	310A	200A	155A
		U ₂	32.4V	28V	26.2V
	1 ~ 50 Hz	U ₁ = 220	I _{1max} = 117.2A	I _{1Eff} = 59A	
		U ₁ = 380	I _{1max} = 72.2A	I _{1Eff} = 36A	
		U ₁ = 415	I _{1max} = 63.8A	I _{1Eff} = 32A	
		IP 21S			

S-178 813-A

2-3. Symbols And Definitions

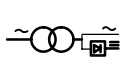
NOTE 	<i>Some symbols are found only on CE products.</i>
---	--

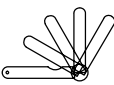
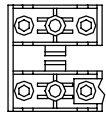
A	Amperes		Panel-Local		Gas Tungsten Arc Welding (GTAW)		Shielded Metal Arc Welding (SMAW)
V	Volts		Do Not Switch While Welding		Arc Force (DIG)		Spot Timer
	Output		Circuit Breaker		Remote		Temperature
	Protective Earth (Ground)		Alternating Current		High Frequency - Start		Input
	Postflow Timer		Prewflow Timer		High Frequency - Continuous	HF	High Frequency
	Gas (Supply)		Gas Input		Gas Output		Increase/Decrease Of Quantity
I	On		Off	%	Percent		Direct Current
	Balance Control		Maximum Cleaning		Maximum Penetration		Electrode Positive
	Electrode Negative		Crater Time		Meter		Single-Phase
U₀	Rated No Load Voltage (Average)	U₁	Primary Voltage	U₂	Conventional Load Voltage		Line Connection
I₁	Primary Current	I₂	Rated Welding Current	X	Duty Cycle		Single-Phase Combined AC/DC Power Source
IP	Degree Of Protection	I_{1eff}	Maximum Effective Supply Current	I_{1max}	Rated Maximum Supply Current	Hz	Hertz
	Electrode		Work		Thickness Gauge		Spark Gap
S	Seconds						

SECTION 3 – INSTALLATION

3-1. Specifications

Rated Welding Output	PFC**	Amperes Input at AC Balanced Rated Load Output, 50/60 Hz, Single-Phase				KVA	KW	Amp Range	Max OCV	IP Rating
		200 V	230 V	460 V	575 V					
NEMA Class II (40) – 250 Amperes, 30 Volts AC, 40% Duty Cycle	No PFC	106 (4.6*)	92 (4*)	46 (2*)	37 (1.6*)	21 (0.89*)	11.4 (0.68*)	5–310 A	80 V	21
	With PFC	76	66	33	26	15.2	11.4			

*While idling
**Power Factor Correction

Rated Welding Output	PFC**	Amperes Input at AC Balanced Rated Load Output, 50/60 Hz, Single-Phase									KVA	KW	Amp Range	Max OCV	IP Rating
		200 V	220 V	230 V	260 V	380 V	415 V	460 V	520 V	575 V					
NEMA Class I (60) – 200 Amperes, 28 Volts AC, 60% Duty Cycle	No PFC	85 (4.6*)	77 (4.2*)	74 (4*)	65 (3.5*)	45 (2.4*)	41 (2.2*)	37 (2*)	33 (1.8*)	30 (1.6*)	17 (0.9*)	8.3 (0.7*)	5–310 A	80 V	21
	With PFC	55 (57*)	64 (51*)	48 (49*)	48 (49*)	37 (30*)	34 (27*)	24 (25*)	48 (49*)	19 (20*)	11 (11*)	8.3 (0.6*)			

*While idling
**Power Factor Correction

3-2. Volt-Ampere Curves

The volt-ampere curves show the minimum and maximum voltage and amperage output capabilities of the welding power source. Curves of other settings fall between the curves shown.

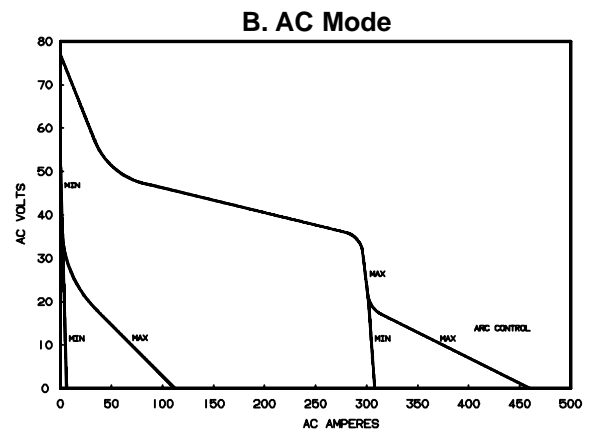
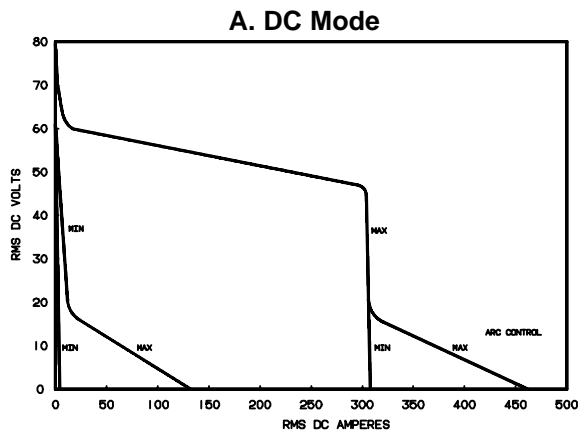

3-3. Duty Cycle And Overheating

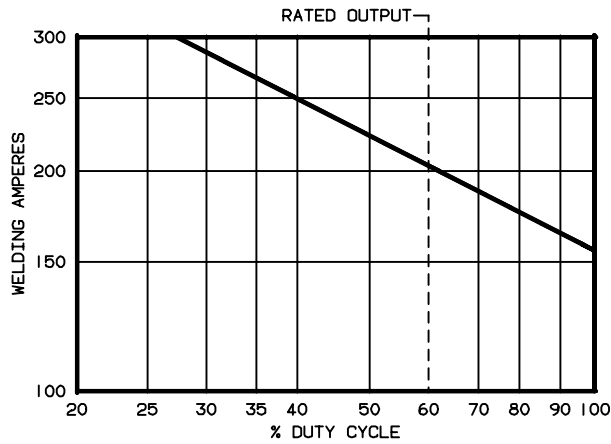

Duty Cycle is percentage of 10 minutes that unit can weld at rated load without overheating.

If unit overheats, thermostat opens, output stops, light goes on (CE models only), and cooling fan runs. Wait fifteen minutes for unit to cool. Reduce amperage or duty cycle before welding.

▲ Exceeding duty cycle can damage unit and void warranty.

40% Duty Cycle At 250 Amperes (60 Hz Models Only)

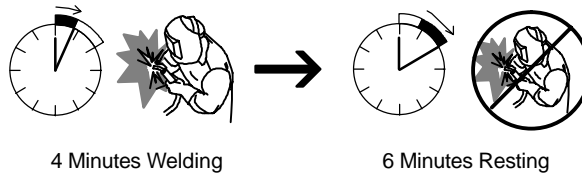

60% Duty Cycle At 200 Amperes

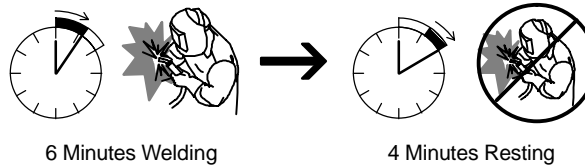

Overheating

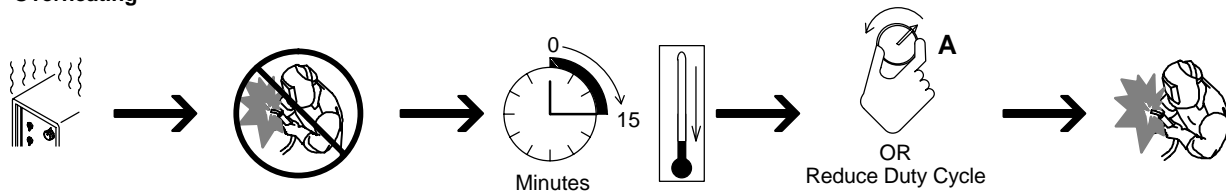

duty1 4/95 / SB-116 198

3-4. Selecting A Location



Movement

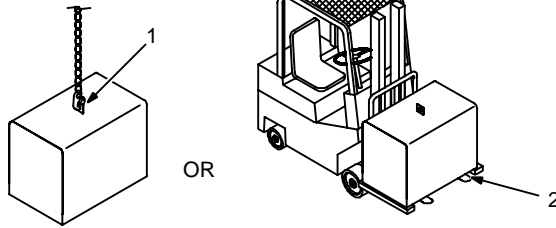

1 Lifting Eye
 2 Lifting Forks
 Use lifting eye or lifting forks to move unit.

If using lifting forks, extend forks beyond opposite side of unit.

3 Rating Label (Non CE Models Only)
 4 Rating Label (CE Models Only, See Section 2-2)

Use rating label to determine input power needs. CE label located on rear panel.

5 Plate Label (CE Models Only)
 6 Line Disconnect Device

Locate unit near correct input power supply.

▲ **Special installation may be required where gasoline or volatile liquids are present – see NEC Article 511 or CEC Section 20.**

Location And Airflow

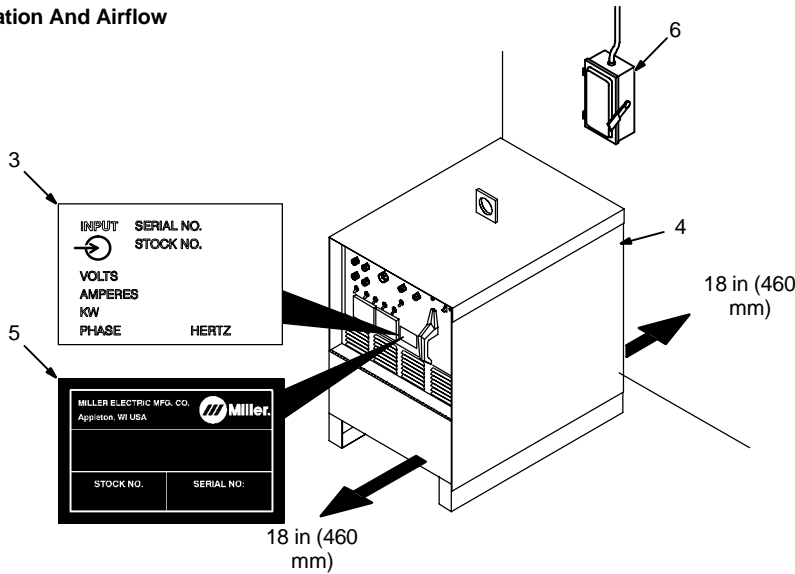

ST-800 402 / ST-117 264-F

3-5. Dimensions And Weights

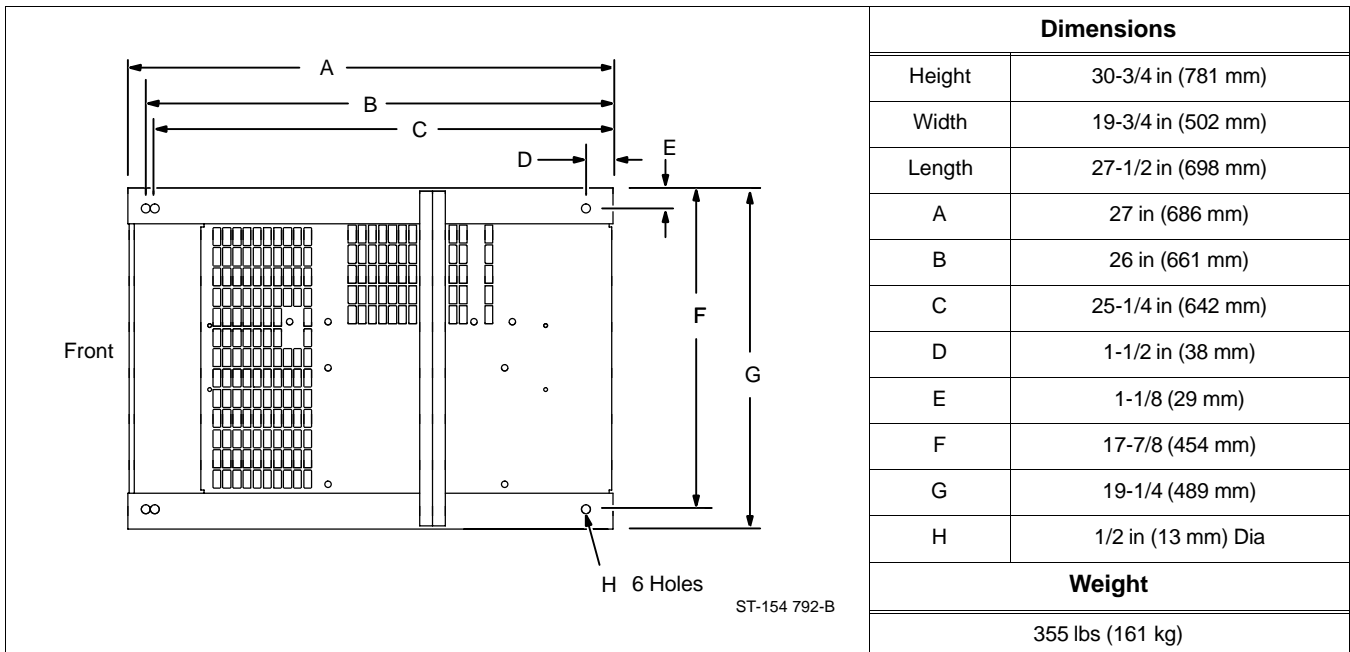

3-6. Tipping



▲ Be careful when placing or moving unit over uneven surfaces.

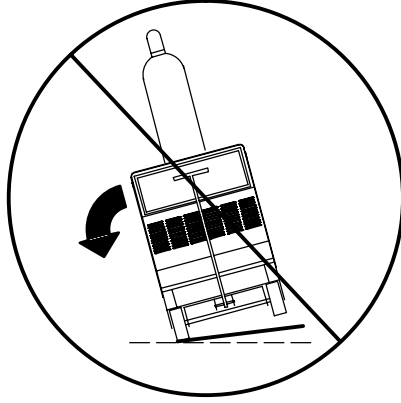

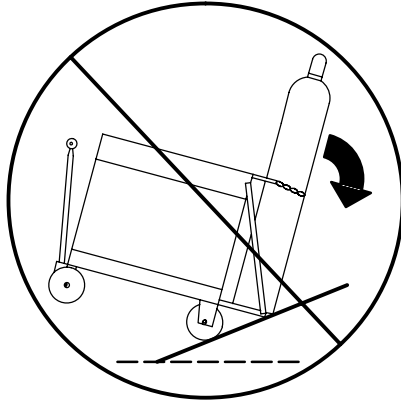

3-7. Weld Output Terminals And Selecting Cable Sizes



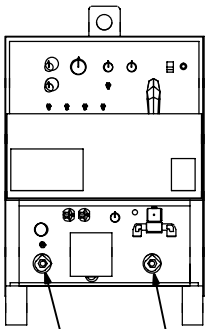

▲ **ARC WELDING** can cause **Electromagnetic Interference**.

To reduce possible interference, keep weld cables as short as possible, close together, and down low, such as on the floor. Locate welding operation 100 meters from any sensitive electronic equipment. Be sure this welding machine is installed and grounded according to this manual. If interference still occurs, the user must take extra measures such as moving the welding machine, using shielded cables, using line filters, or shielding the work area.

 Weld Output Terminals	Welding Amperes	Total Cable (Copper) Length In Weld Circuit Not Exceeding							
		100 ft (30 m) Or Less		150 ft (45 m)	200 ft (60 m)	250 ft (70 m)	300 ft (90 m)	350 ft (105 m)	400 ft (120 m)
		10 – 60% Duty Cycle	60 – 100% Duty Cycle	10 – 100% Duty Cycle					
 Work Electrode ST-154 795-C	100	4	4	4	3	2	1	1/0	1/0
	150	3	3	2	1	1/0	2/0	3/0	3/0
	200	3	2	1	1/0	2/0	3/0	4/0	4/0
	250	2	1	1/0	2/0	3/0	4/0	2-2/0	2-2/0
	300	1	1/0	2/0	3/0	4/0	2-2/0	2-3/0	2-3/0
	350	1/0	2/0	3/0	4/0	2-2/0	2-3/0	2-3/0	2-4/0
	400	1/0	2/0	3/0	4/0	2-2/0	2-3/0	2-4/0	2-4/0
	500	2/0	3/0	4/0	2-2/0	2-3/0	2-4/0	3-3/0	3-3/0

Weld cable size (AWG) is based on either a 4 volts or less drop or a current density of at least 300 circular mils per ampere. Contact your distributor for the mm² equivalent weld cable sizes. S-0007-E

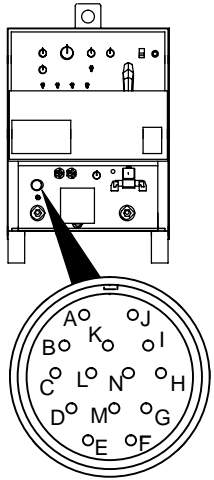
3-8. Remote 14 Receptacle

 <p>ST-154 795-C</p>		Socket*	Socket Information
		A	24 volts ac.
	A	B	Contact closure to A completes 24 volts ac contactor control circuit.
		C	Command reference; 0 to +10 volts dc output to remote control.
		D	Remote control circuit common.
		E	0 to +10 volts dc input command signal from remote control.
K		Chassis common.	
<p>*The remaining sockets are not used.</p>			

3-9. 115 Volts AC Duplex Receptacle And Shielding Gas Connections



▲ Turn Off power before connecting to receptacle.

- 1 115 V AC Receptacle
- 2 Gas Valve In Fitting
- 3 Gas Valve Out Fitting

Fittings have 5/8-18 right-hand threads

- 4 Cylinder Valve

Open valve slightly so gas flow blows dirt from valve. Close valve.

- 5 Regulator/Flow Gauge
- 6 Flow Adjust

Typical flow rate is 20 cfh (cubic feet per hour) (9.4 L/min)

- 7 High Frequency Control (see Section 4-1)

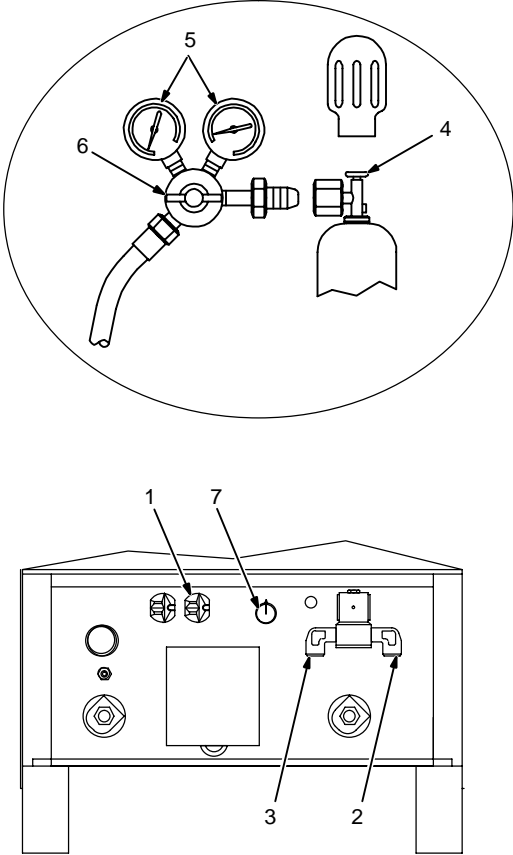

Ref. ST-154 795-C / Ref. ST-157 858

3-10. Electrical Service Guide

NOTE 	<i>All values calculated at 60% duty cycle.</i>
---	---

60 Hertz Models	Without Power Factor Correction				With Power Factor Correction			
Input Voltage	200	230	460	575	200	230	460	575
Input Amperes At Rated Output	85	74	37	30	55	48	24	19
Max Recommended Standard Fuse Or Circuit Breaker Rating In Amperes	125	110	60	45	80	70	35	30
Min Input Conductor Size In AWG/Kcmil	4	6	10	10	8	8	12	14
Max Recommended Input Conductor Length In Feet (Meters)	173 (53)	158 (48)	291 (89)	455 (139)	86 (26)	114 (35)	186 (58)	189 (48)
Min Grounding Conductor Size In AWG/Kcmil	6	6	10	10	8	8	12	14
Reference: 1996 National Electrical Code (NEC)								S-0092-J

50 Hertz Models	Without Power Factor Correction					With Power Factor Correction		
Input Voltage	220	260	380	415	520	220	380	415
Input Amperes At Rated Output	77	65	45	41	33	64	37	34
Max Recommended Standard Fuse Or Circuit Breaker Rating In Amperes	125	100	70	60	50	90	60	50
Min Input Conductor Size In AWG/Kcmil	6	6	8	8	10	6	10	10
Max Recommended Input Conductor Length In Feet (Meters)	145 (44)	202 (62)	291 (89)	347 (106)	372 (113)	145 (44)	291 (89)	347 (106)
Min Grounding Conductor Size In AWG/Kcmil	6	8	8	10	10	6	8	10
Reference: 1996 National Electrical Code (NEC)								S-0092-J

3-11. Placing Jumper Links And Connecting Input Power

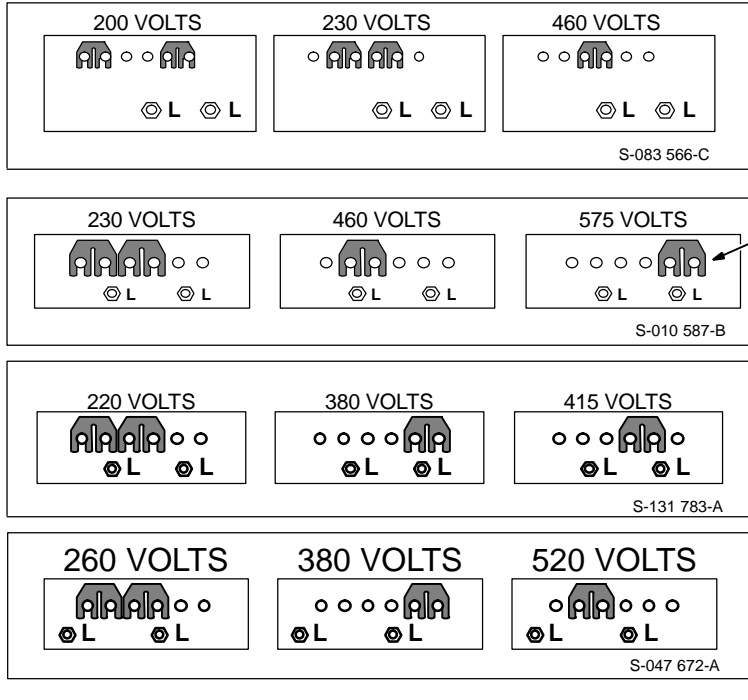

Check input voltage available at site.

1 Jumper Link Label

Check label inside your unit—only one label is on unit.

▲ Only make connections for the voltages shown on the label inside your unit. Do not make connections for any other voltages. If jumper link label is missing from inside unit, check rating label (see Section 3-4) for allowable input voltages.

2 Jumper Links

Move jumper links to match input voltage.

3 Input And Grounding Conductors

Select size and length using Section 3-10.

4 Line Disconnect Device

Select type and size of overcurrent protection using Section 3-10.

Reinstall side panel.

▲ Special installation may be required where gasoline or volatile liquids are present – see NEC Article 511 or CEC Section 20.

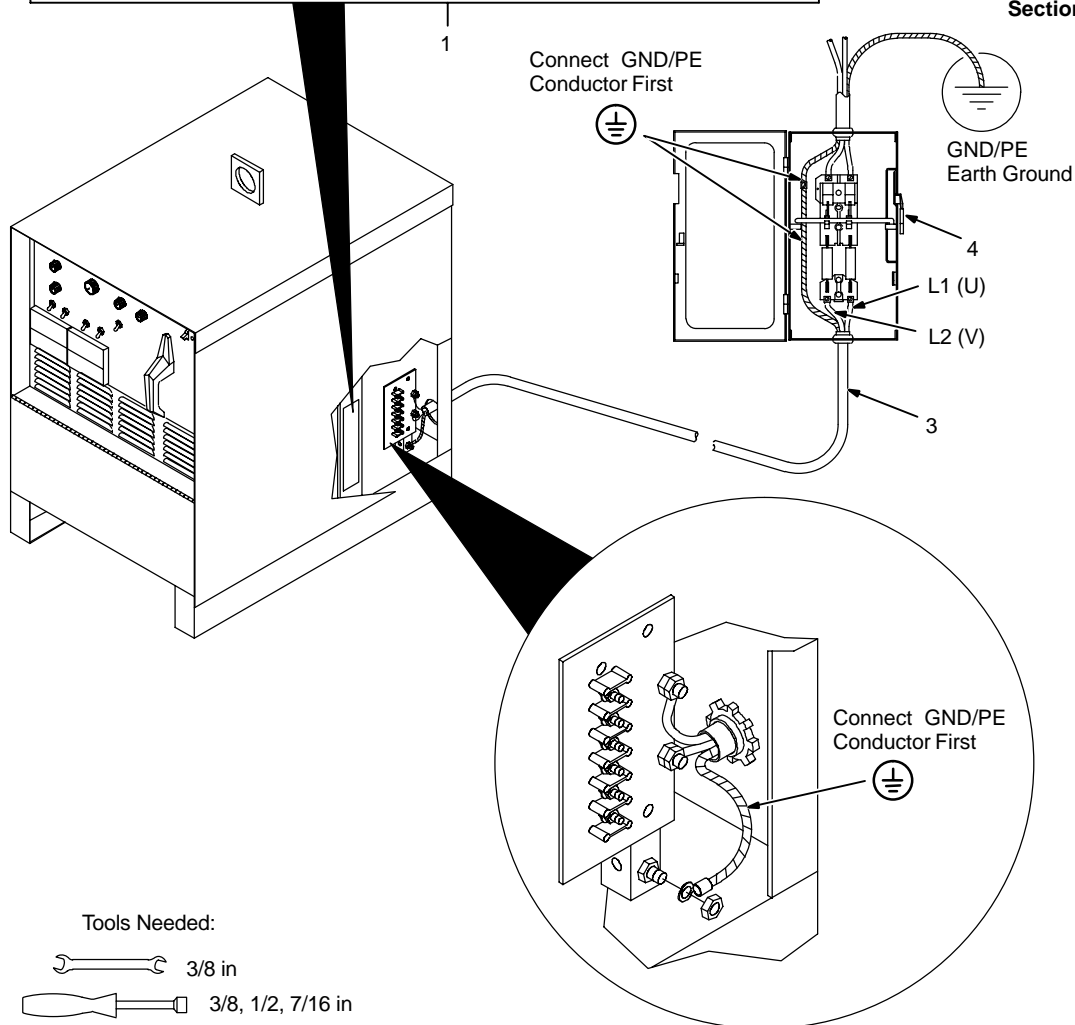

Tools Needed:

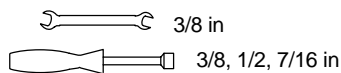

ST-117 263-K

SECTION 4 – OPERATION

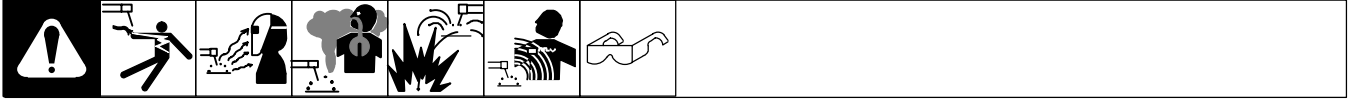

4-1. Controls

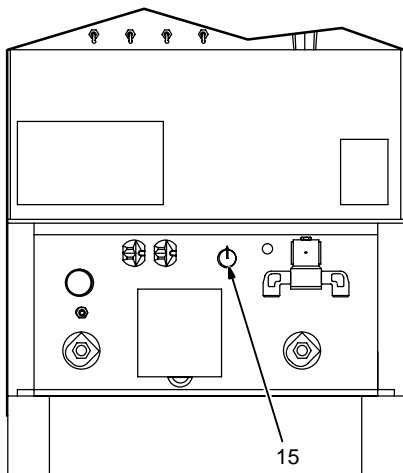
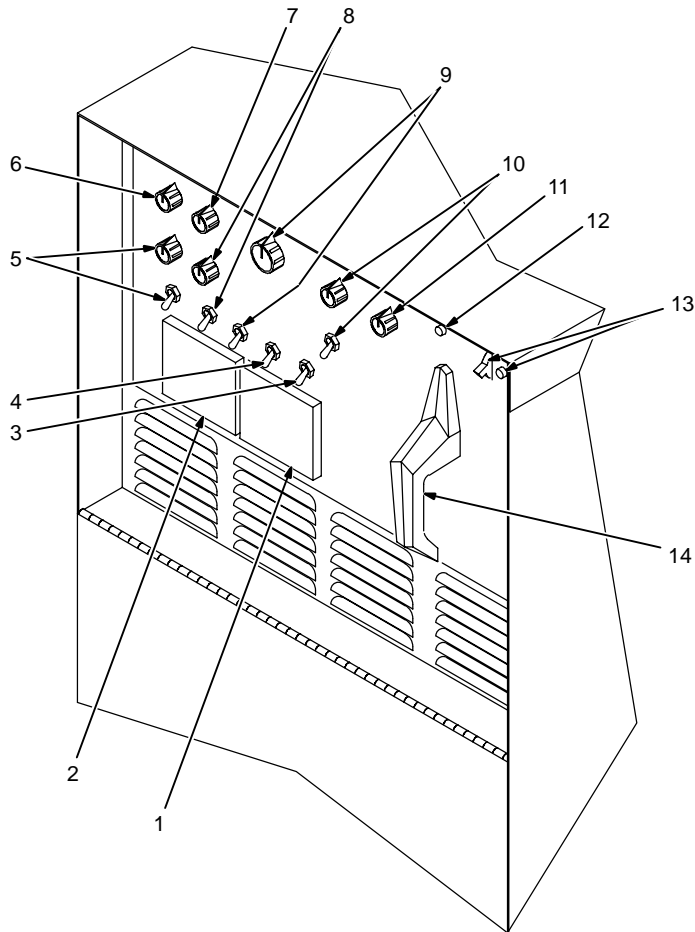

- 1 Ammeter
See Section 4-3.
- 2 Voltmeter
See Section 4-3.
- 3 High Frequency Switch
See Section 4-11.
- 4 Output (Contactor) Switch
See Section 4-8.
- 5 Spot Time Switch And Control (Optional)
See Section 4-5.
- 6 Preflow Time Control (Optional)
See Section 4-12.
- 7 AC Balance Control
See Section 4-6.
- 8 Crater Time Control And Switch
See Section 4-4.
- 9 Amperage Adjustment Control And Switch
See Section 4-7.
- 10 Arc Force (Dig) Switch And Control
See Section 4-9.
- 11 Postflow Time Control
See Section 4-10.
- 12 High Temperature Shutdown Light (CE Models Only)
Lights when unit overheats and shuts down (see Section 3-3).
- 13 Power Switch And Pilot Light
Use switch to turn unit and light On and Off.
- 14 Output Selector Switch
See Section 4-2.
- 15 High Frequency Control
See Section 4-11.

4-2. Output Selector Switch

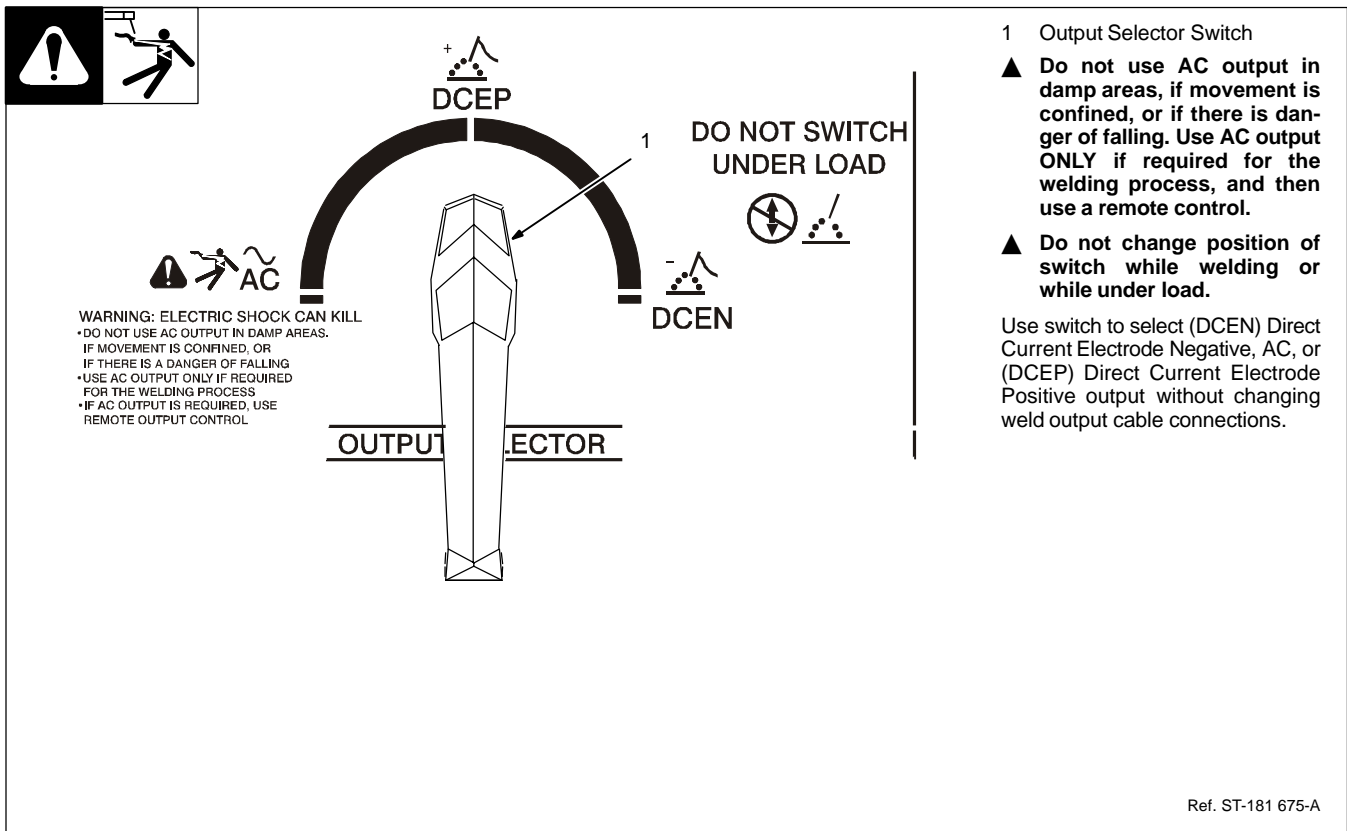

The diagram shows a central vertical component labeled "OUTPUT SELECTOR" with a semi-circular switch mechanism on top. The switch has three positions: "DCEP" (Direct Current Electrode Positive) at the top, "AC" in the middle, and "DCEN" (Direct Current Electrode Negative) at the bottom. A number "1" points to the switch mechanism. To the left, there is a warning icon (a triangle with an exclamation mark) and a person being struck by a lightning bolt, with the text "AC". Below this is a warning box. To the right, there is a warning icon (a triangle with an exclamation mark) and a person being struck by a lightning bolt, with the text "DO NOT SWITCH UNDER LOAD". Below this is another warning box. At the bottom right, there is a reference number "Ref. ST-181 675-A".

WARNING: ELECTRIC SHOCK CAN KILL

- DO NOT USE AC OUTPUT IN DAMP AREAS.
- IF MOVEMENT IS CONFINED, OR IF THERE IS A DANGER OF FALLING
- USE AC OUTPUT ONLY IF REQUIRED FOR THE WELDING PROCESS
- IF AC OUTPUT IS REQUIRED, USE REMOTE OUTPUT CONTROL

DO NOT SWITCH UNDER LOAD

1 Output Selector Switch

- ▲ Do not use AC output in damp areas, if movement is confined, or if there is danger of falling. Use AC output ONLY if required for the welding process, and then use a remote control.
- ▲ Do not change position of switch while welding or while under load.

Use switch to select (DCEN) Direct Current Electrode Negative, AC, or (DCEP) Direct Current Electrode Positive output without changing weld output cable connections.

Ref. ST-181 675-A

4-3. Meters

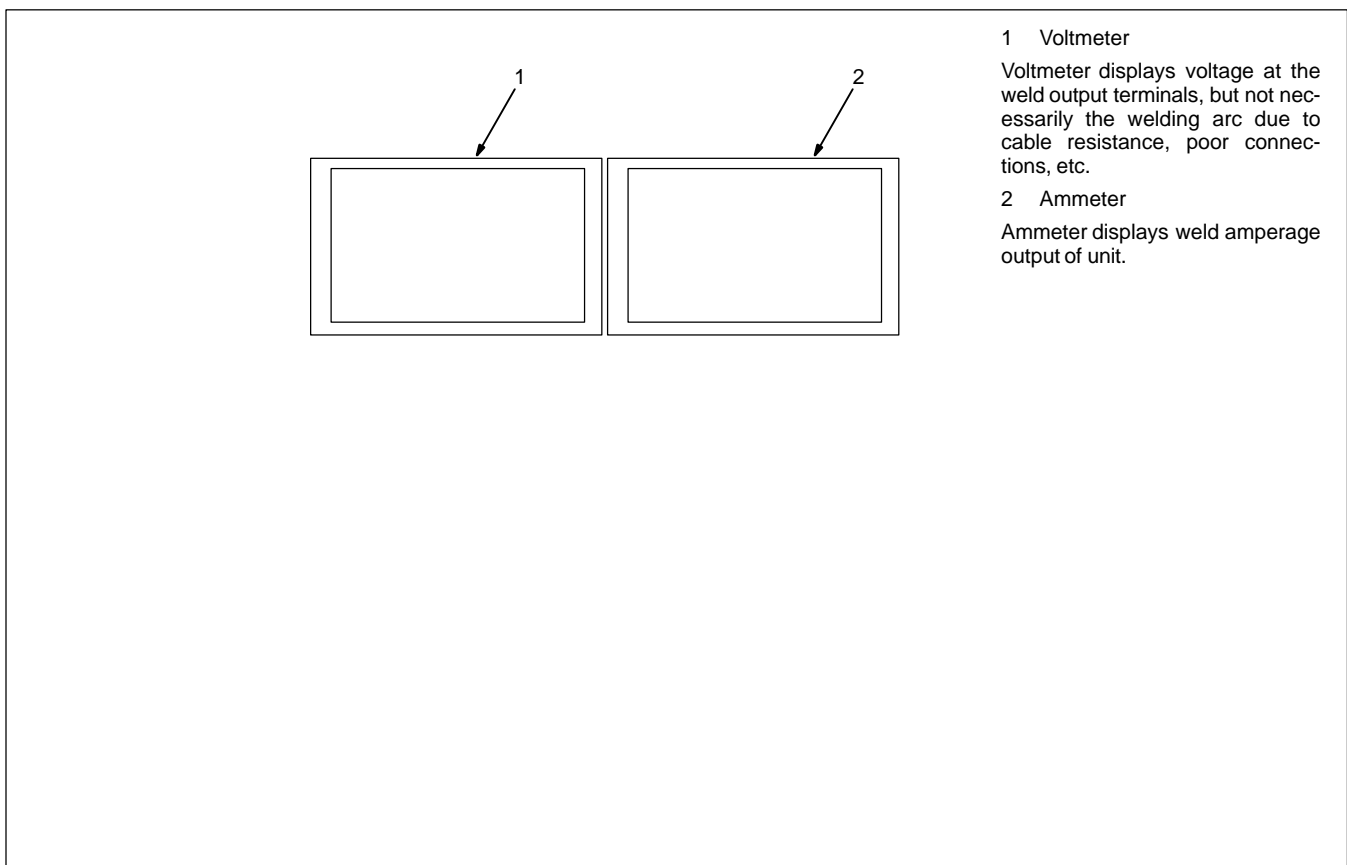

The diagram shows two rectangular meters side-by-side. The left meter is labeled "1" and the right meter is labeled "2".

1 Voltmeter
Voltmeter displays voltage at the weld output terminals, but not necessarily the welding arc due to cable resistance, poor connections, etc.

2 Ammeter
Ammeter displays weld amperage output of unit.

4-4. Crater Time Controls

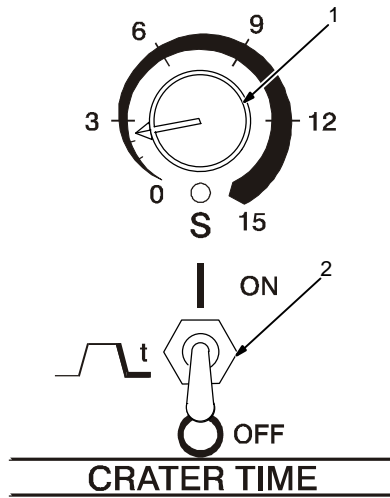

1 Crater Time Control

Use control to reduce current over a set period of time (0–15 seconds) at the end of the weld cycle when NOT using a remote current control.

2 Crater Time Switch

ON – provides crater time.

OFF – provides no crater time.

Place switch in the OFF position for Shielded Metal Arc Welding (SMAW).

Application:

Crater Time should be used while GTAW welding materials that are crack sensitive, and/or the operator wants to eliminate the crater at the end of the weld.

Note: This applies if the operator is using an on/off only type control to start and stop the welding process.

4-5. Spot Time Controls

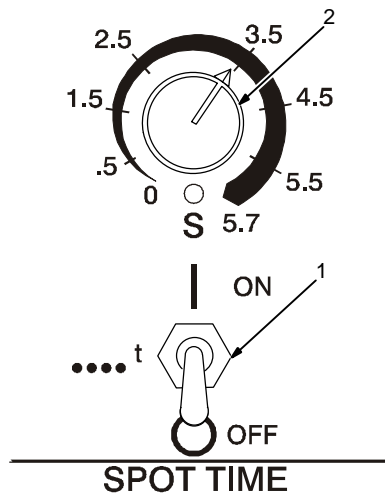

1 Spot Time Switch

Place switch in the ON position to turn on spot weld circuitry.

The (GTAW) TIG Spot process is generally used with a direct current electrode negative (DCEN) set-up.

Place switch in the OFF position to turn off spot weld circuitry. Put switch in the OFF position while doing Shielded Metal Arc Welding (SMAW).

2 Spot Time Control

Use control to set time (0–5.7 seconds) for Gas Tungsten Arc (GTAW) spot welds. Spot time begins at arc initiation. If the arc is broken during the spot time cycle, the timer stops but does not reset. When the spot time has ended, weld output stops. Postflow starts when the remote contactor is opened. The spot timer resets after the contactor opens.

Application:

TIG spot welding is used for joining thinner materials that are in close contact, with the fusion method. A good example would be joining coil ends.

4-6. AC Balance Control

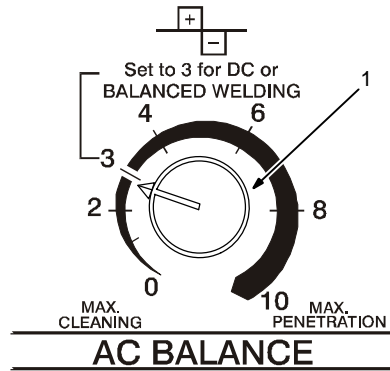

1 AC Balance Control

Balance Control (AC GTAW):

Control changes the AC output square wave. Rotating the control towards 10 provides deeper penetration. Rotating the control towards 0 provides more cleaning action of the workpiece.





When the control is in the Balanced position, the wave shape provides equal penetration and cleaning action.

Application:

When welding on oxide forming materials such as aluminum or magnesium, excess cleaning is not necessary. To produce a good weld, only a minimal amount, approximately a 0.10 in (2.5mm) of etched zone along the weld toes is required.

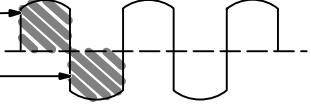
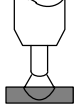
Set control to 7 and adjust as necessary. Joint configuration, set-up, process variables, and oxide thickness may affect setting.

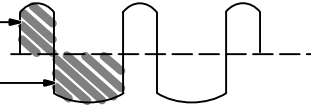
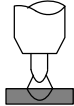
Arc rectification can occur when welding above 200 amps and/or while welding with helium gas. If this condition occurs, increasing the Balance control towards maximum penetration, may help to restabilize the arc.

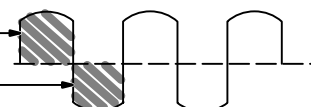
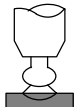
Setting	Output Waveforms	Arc
Balanced 3 	50% Electrode Positive  50% Electrode Negative	
More Penetration 10 	32% Electrode Positive  68% Electrode Negative	
More Cleaning 0 	55% Electrode Positive  45% Electrode Negative	

Ref. S-0795-A

4-7. Amperage Adjustment Controls

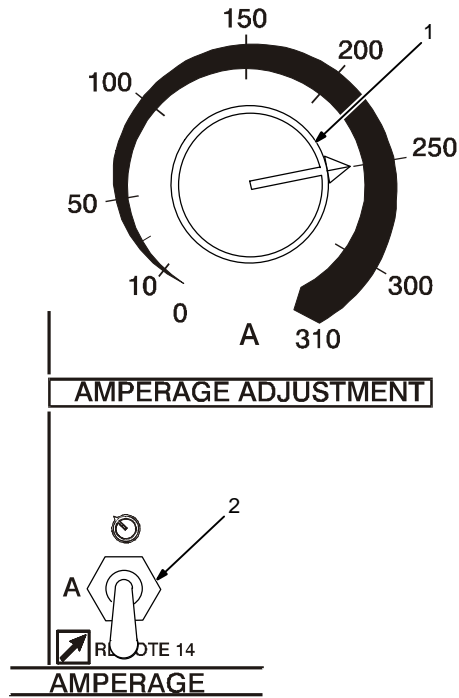

1 Amperage Adjustment Control
Use control to adjust amperage, and preset amperage on ammeter (see Section 4-3). This control may be adjusted while welding.

For remote amperage control, front panel control setting is the maximum amperage available. For example: If front panel control is set to 200 A, the range of the remote amperage control is 5 to 200 A.

For spot welding, use Amperage Adjust control to select from 5–310 amps of peak amperage (see Section 4-5).

2 Amperage Control Switch

Use switch to select way of controlling amperage adjustment.

For front panel control, place switch in the PANEL position.

For remote control, place switch in REMOTE 14 position, and connect remote control device (see Section 3-8).

4-8. Output (Contactor) Control Switch

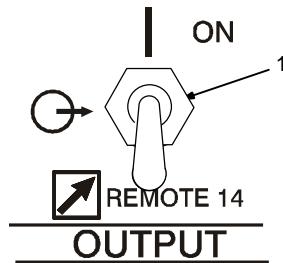

▲ **Weld output terminals are energized when Output (Contactor) switch is On and Power is On.**

1 Output/Contactor Switch

Use switch to select way of controlling unit output.

For front panel control, place switch in ON position.

When On is selected, HF and gas control are disabled.

For remote control, place switch in REMOTE 14 position, and connect remote control device (see Section 3-8).

4-9. Arc Controls

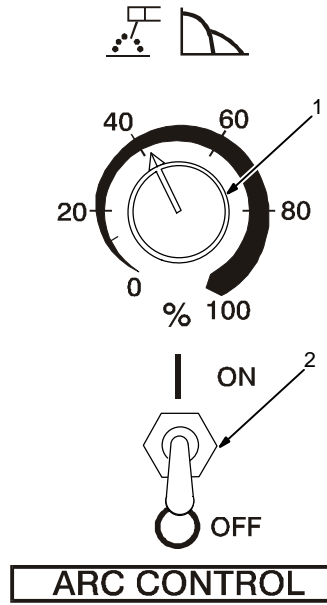

1 Arc Control (Dig)

For AC And DC SMAW Welding

When set at 0, short-circuit amperage at low arc voltage is the same as normal welding amperage.

When setting is increased, short-circuit amperage at low arc voltage increases.

Set at 0 for GTAW welding.

2 Arc Control Switch

Place switch in the ON position to turn on arc control circuitry. When switch is in the OFF position, no additional amperage is available at low arc voltages. Place switch in the OFF position while performing Gas Tungsten Arc Welding (GTAW).

Application:

Control helps arc starting or making vertical or overhead welds by increasing amperage at low arc voltage, and reduces electrode sticking while welding.

4-10. Postflow Time Control

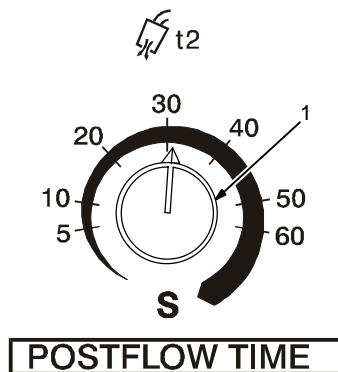

1 Postflow Time Control

Use control to set length of time (0–70 seconds) gas flows after welding stops. It is important to set enough time to allow gas to flow until after the tungsten and weld puddle has cooled down.

Application:

Postflow is required to cool tungsten and weld, and to prevent contamination of tungsten and weld. Increase postflow time if tungsten or weld are dark in appearance.

4-11. High Frequency Controls

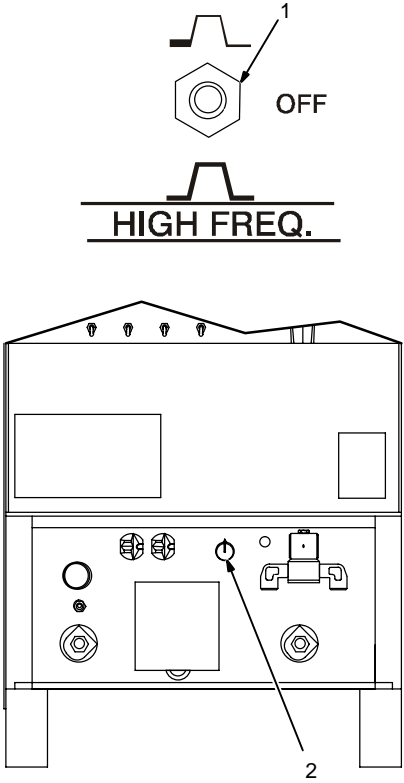

▲ Place High Frequency switch in Off position before using the shielded metal arc welding (SMAW) process.

1 High Frequency Switch

START – (Up position) provides HF for arc starting only. High frequency turns on to help start arc when output is enabled. High frequency turns off when arc is started, and turns on whenever arc is broken to help restart arc.

Application:
HF Start is used when the DCEN GTAW process is required.

OFF – provides no HF. Use OFF for SMAW (stick electrode) welding.

CONTINUOUS – (Down position) provides HF continuously throughout the weld.

Application:
HF Continuous is used when the AC GTAW process is required.

2 High Frequency Intensity Control

Use control to change amount of HF energy used to start and maintain the arc. Set as low as practical to prevent interfering with electronic equipment.

4-12. Preflow Time Control (Optional)

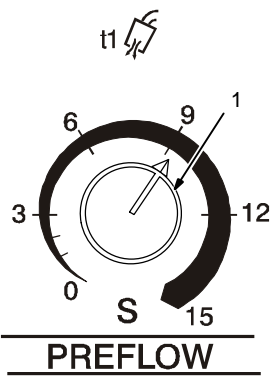

1 Preflow Time Control

Use control to set the length of time (0–15 seconds) that gas flows before an arc is started.

Application:
Preflow is used to purge the immediate weld area of atmosphere. Preflow also aids in consistent arc starting.

SECTION 5 – THEORY OF OPERATION

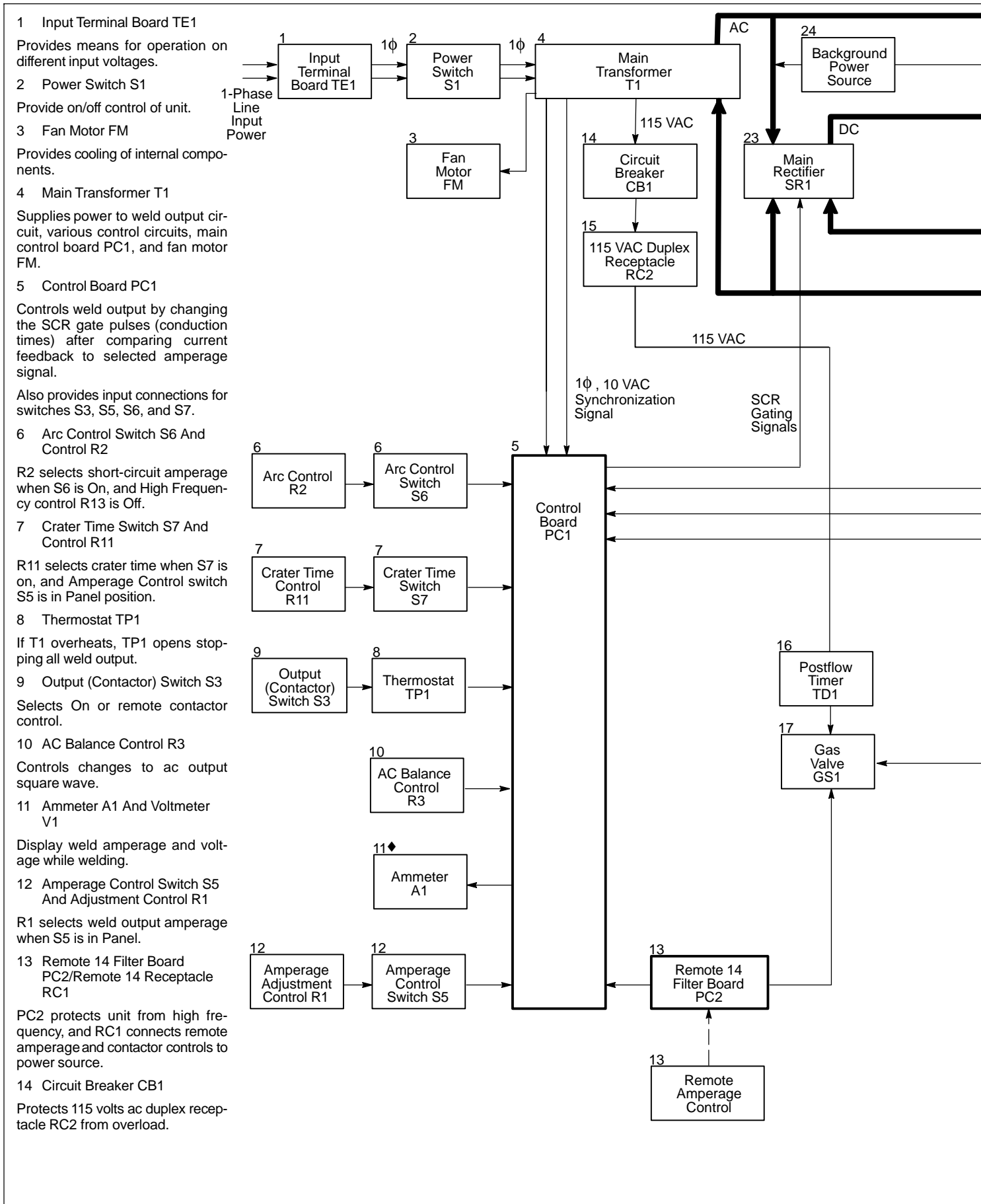



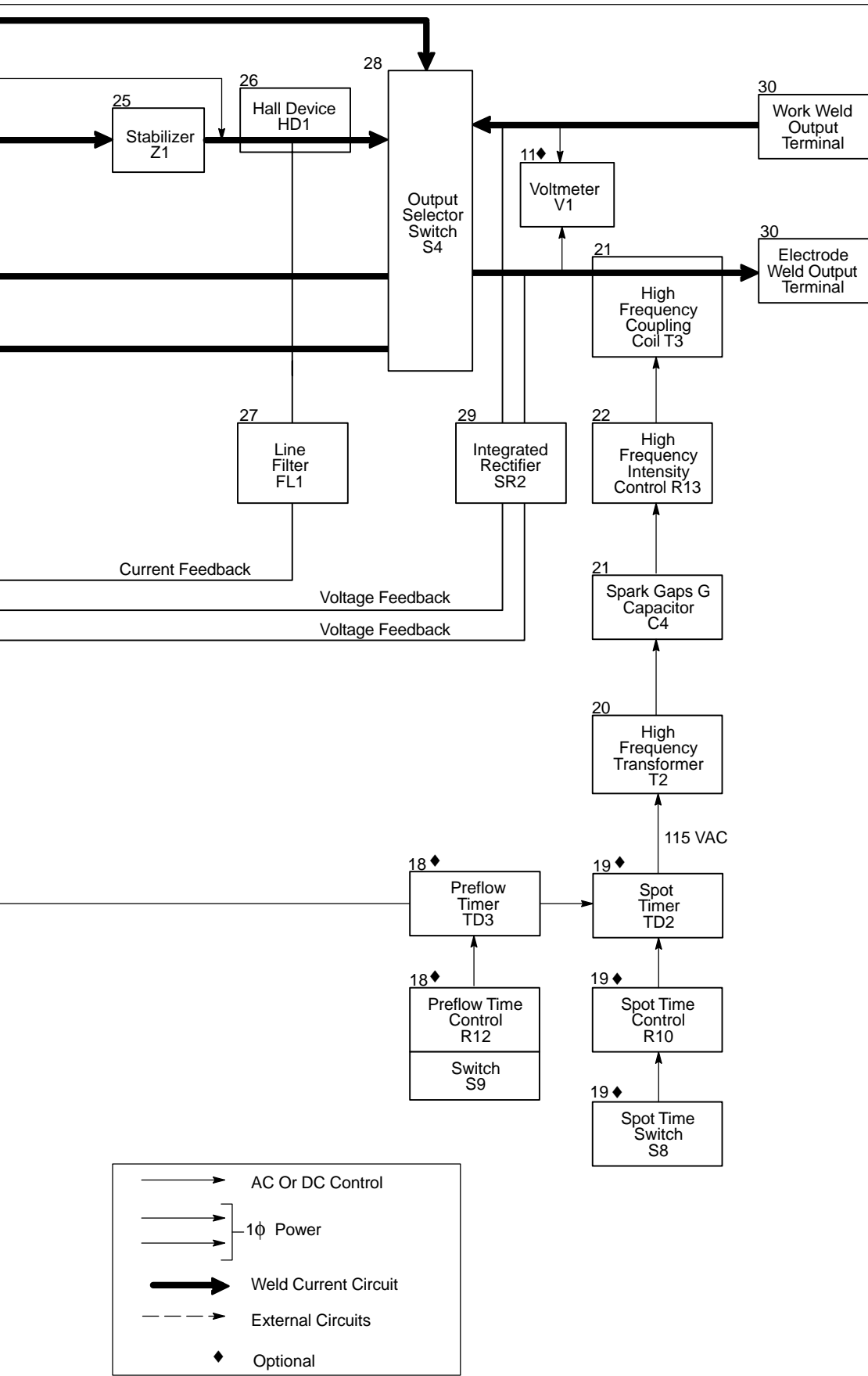



- 1 Input Terminal Board TE1
Provides means for operation on different input voltages.
- 2 Power Switch S1
Provide on/off control of unit.
- 3 Fan Motor FM
Provides cooling of internal components.
- 4 Main Transformer T1
Supplies power to weld output circuit, various control circuits, main control board PC1, and fan motor FM.
- 5 Control Board PC1
Controls weld output by changing the SCR gate pulses (conduction times) after comparing current feedback to selected amperage signal.
Also provides input connections for switches S3, S5, S6, and S7.
- 6 Arc Control Switch S6 And Control R2
R2 selects short-circuit amperage when S6 is On, and High Frequency control R13 is Off.
- 7 Crater Time Switch S7 And Control R11
R11 selects crater time when S7 is on, and Amperage Control switch S5 is in Panel position.
- 8 Thermostat TP1
If T1 overheats, TP1 opens stopping all weld output.
- 9 Output (Contactor) Switch S3
Selects On or remote contactor control.
- 10 AC Balance Control R3
Controls changes to ac output square wave.
- 11 Ammeter A1 And Voltmeter V1
Display weld amperage and voltage while welding.
- 12 Amperage Control Switch S5 And Adjustment Control R1
R1 selects weld output amperage when S5 is in Panel.
- 13 Remote 14 Filter Board PC2/Remote 14 Receptacle RC1
PC2 protects unit from high frequency, and RC1 connects remote amperage and contactor controls to power source.
- 14 Circuit Breaker CB1
Protects 115 volts ac duplex receptacle RC2 from overload.



- 15 115 Volts AC Duplex Receptacle RC2
Provides connection point for auxiliary equipment.
- 16 Postflow Timer TD1
Controls shielding gas and coolant postflow time.
- 17 Gas Valve GS1
Provides shielding gas during the weld cycle.
- 18 Preflow Timer TD3, Control R12, And Switch S9
R12 selects time shielding gas flows before arc starts. S9 is an integral part of R12 so that when R12 is turned past zero (0), TD3 is off.
- 19 Spot Timer TD2, Switch S8, And Control R10
R10 selects time output is available when spot welding. S8 selects Off or spot welding with remote contactor control.
- 20 High Frequency Transformer T2
Steps up input voltage and charges capacitor C4.
- 21 Spark Gaps G And High Frequency Coupling Coil T3
G provides path for C4 to discharge into T3. T3 supplies high-frequency to welding circuit.
- 22 High Frequency Intensity Control R13
Changes amount of HF energy used to start and maintain the arc.
- 23 Main Rectifier SR1
Changes the ac output from T1 to full-wave rectified dc.
- 24 Background Power Source
Provides reduced weld output ripple at low weld output levels.
- 25 Stabilizer Z1
Smooths dc welding current.
- 26 Hall Device HD1
Provides current feedback signal to PC1 through line filter FL1.
- 27 Line Filter FL1
Filters current feedback signal.
- 28 Output Selector Switch S4
Provides either AC or DC and output polarity.
- 29 Integrated Rectifier SR2
Provides dc voltage feedback to PC1.
- 30 Electrode And Work Weld Output Terminals
Provide weld output.

SECTION 6 – TROUBLESHOOTING

6-1. Troubleshooting Table

     	
<p>☞ See Section 6-2 for test points and values and Section 10 for parts location.</p> <p>☞ Use MILLER Testing Booklet (Part No. 150 853) when servicing this unit.</p>	
Trouble	Remedy
Prior to Serial No. KG164875, no weld output; unit completely inoperative – Effective with Serial No. KG164875, no weld output; unit completely inoperative; PL2 off.	Be sure line disconnect switch is in the On position.
	Replace building line fuse(s) or reset circuit breaker(s) if open.
	Check for proper electrical input connections (see Section 3-11).
	Check for proper jumper link position (see Section 3-11).
Prior to Serial No. KG164875, no weld output; fan runs – Effective with Serial No. KG164875, no weld output; fan runs; PL2 on.	If using remote control, place Output (Contactor) switch S3 in Remote 14 position, and connect remote control to Remote 14 receptacle RC1 (see Sections 3-8 and Section 4-8). If remote is not being used, place Output switch S3 in On position.
	Check, repair or replace remote control device.
	Allow a cooling period of approximately 15 minutes. If thermostats TP1 remain open, check continuity and replace if necessary (see Section 3-3).
	Check circuit breaker CB1, and reset if open (see Section 7-2).
	Place Output Selector switch S4 in desired position (see Section 4-2).
	Check optional preflow timer board TD3, and replace if necessary.
	Check optional spot timer relay TD2 for proper connections and resistance. Replace TD2 if necessary.
	Check continuity of Spot Time switch S8. Check condition of contacts. Repair or replace S8 if necessary.
	Check SR1, and replace necessary components. If components are replaced, check capacitors C7 thru C10. Replace capacitor(s) if necessary.
	Check control board PC1 and connections, and replace if necessary.
Unit provides only minimum weld output.	Effective with Serial No. KB110695, check resistance and connections of HD1; HD1 is 1600 ohms $\pm 10\%$ between pins 1 and 3 of plug PLG3. Check input and output voltages. Replace HD1 if necessary.
	Check position of Amperage Control switch S5 (see Section 4-7).
	Increase Amperage Adjustment control R1 setting if a remote control is used (see Section 4-7).
	Check, repair or replace remote control device.
	Check resistance and connections of Amperage Adjustment control R1; R1 is 1000 ohms $\pm 10\%$. Replace R1 if necessary.
	Check SCRs in main rectifier SR1, and replace if necessary. If any SCRs are replaced, Check capacitors C7 through C10 for a short or open, and check for proper connections. Replace C7 through C10 if necessary.
Unit provides only maximum weld output.	Check control board PC1 and connections, and replace if necessary.
	Effective with Serial No. KB110695, check resistance and connections of HD1; HD1 is 1600 ohms $\pm 10\%$ between pins 1 and 3 of plug PLG3. Check input and output voltages. Replace HD1 if necessary.
	Check Amperage Adjustment control R1 for proper connections and resistance; R1 is 1000 ohms $\pm 10\%$. Replace R1 if necessary.
	Effective with Serial No. KB110695, check resistance and connections of HD1; HD1 is 1600 ohms $\pm 10\%$ between pins 1 and 3 of plug PLG3. Check input and output voltages. Replace HD1 if necessary.
	Check connections for continuity to shunt device on units with Serial No. prior to KB110695.
	Check bypass capacitors C13, C14, C16, C17, C18, and C19 for broken leads, shorts, and leakage. Replace if necessary.

Trouble	Remedy
	<p>Check SCRs in main rectifier SR1, and replace if necessary. If any SCRs are replaced, Check capacitors C7 through C10 for a short or open, and check for proper connections. Replace C7 through C10 if necessary.</p> <p>Check control board PC1 and connections, and replace if necessary.</p> <p>Check connections to line filter FL1. Check input to PC1. Replace FL1 if necessary.</p>
Erratic weld output.	<p>Check for poor or improper input or output connections. See Sections 3-11 and 3-8.</p> <p>Replace electrode.</p> <p>Check torch assembly, and replace if necessary.</p> <p>Check fuse F2 in rectifier SR3 circuit, and replace if necessary.</p> <p>If Amperage Control switch S5 is in the Remote position check, repair, or replace remote amperage control device if necessary.</p> <p>Check connections for continuity to shunt device on units with Serial No. prior to KB110695.</p> <p>Check Amperage Adjustment control R1 for proper connections and resistance; R1 is 1000 ohms $\pm 10\%$. Replace R1 if necessary.</p> <p>Check bypass capacitors C13, C14, C16, C17, C18, and C19 for broken leads, shorts, and leakage. Replace if necessary.</p> <p>Check SCRs in main rectifier SR1, and replace if necessary. If any SCRs are replaced, Check capacitors C7 through C10 for a short or open, and check for proper connections. Replace C7 through C10 if necessary.</p> <p>Check control board PC1 and connections, and replace if necessary.</p>
No or limited ac balance control.	<p>Check AC Balance control R3 for proper connections and resistance; R3 is 5000 ohms $\pm 10\%$. Replace R3 if necessary.</p> <p>Check control board PC1 and connections, and replace if necessary.</p> <p>Check SCRs in main rectifier SR1, and replace if necessary. If any SCRs are replaced, Check capacitors C7 through C10 for a short or open, and check for proper connections. Replace C7 through C10 if necessary.</p>
No crater fill time.	<p>Check position of Crater switch S7 (see Section 4-4).</p> <p>Check position of Crater control R11 (see Section 4-4).</p> <p>Be sure arc voltage is below 24 volts (see Section 3-2. Volt-Ampere Curves).</p> <p>Check position of Amperage Control switch S5, S5 must be in Panel position (see Section 4-7).</p> <p>Check control board PC1 and connections, and replace if necessary.</p>
Crater fill time too long or does not time out.	<p>Check position of Crater control R11 (see Section 4-4).</p> <p>Check resistance and connections of Crater control R11; R11 is 5 meg ohms $\pm 10\%$. Replace R11 if necessary.</p> <p>Check control board PC1 and connections, and replace if necessary.</p>
No arc control.	<p>Place Arc Control switch S6 in the On position.</p> <p>Place High Frequency switch S2 in the Off position.</p> <p>Be sure arc voltage is below 24 volts (see Section 3-2. Volt-Ampere Curves).</p> <p>Check position of Arc Control R2 (see Section 4-9).</p> <p>Check fuse F1 in rectifier SR3 circuit, and replace if necessary.</p> <p>Check resistance and connections of Arc control R2; R2 is 1000 ohms $\pm 10\%$. Replace R1 if necessary.</p> <p>Check control board PC1 and connections, and replace if necessary.</p>
Lack of high frequency at tungsten electrode; difficulty in starting an arc.	<p>Use proper size tungsten for welding application.</p> <p>Use shortest possible cables (see Section 3-7).</p> <p>Check cables and torch for cracked or deteriorated insulation or bad connections. Repair or replace necessary parts.</p> <p>Be sure to disconnect SMAW electrode cable from weld output terminal when GTAW welding.</p> <p>Decrease gas flow setting.</p> <p>Use properly prepared tungsten.</p> <p>Increase setting of High Frequency Intensity control R13 (see Section 4-11).</p> <p>Check spark gaps G, and readjust if necessary (see 7-4).</p>

Trouble	Remedy
No high frequency at spark gaps G.	Check position of High Frequency switch S2 (see Section 4-11).
	Place Output (Contactor) switch S3 in Remote position and be sure remote control is connected to Remote receptacle RC1 (see Section 3-8).
	Check circuit breaker CB1, and reset if open (see Section 7-2).
	Check fuse F1 in rectifier SR2 circuit, and replace if necessary.
	Check coil voltage and connections of contactor control relay CR1. Check continuity of coil and condition of contacts. Replace CR1 if necessary.
	Check coil voltage and connections of contactor control relay CR5. Check continuity of coil and condition of contacts. Replace CR5 if necessary.
	Check spark gaps G, and readjust if necessary (see Section 7-4).
	Check resistance and connections of High Frequency Intensity control R13; R13 is 1.5 ohms \pm 10%. Replace R1 if necessary.
	Check capacitor C4 for a short or open, and check for proper connections. Replace C4 if necessary.
	Check transformer T2 for signs of winding failure. Check continuity across windings, and check for proper connections. Check secondary voltages. Replace T2 if necessary.
	Check coupling coil T3 for signs of winding failure. Check continuity across windings, and check for proper connections. Replace T3 if necessary.
	Check control board PC1 and connections, and replace if necessary.
No preflow time (optional).	Place Output (Contactor) switch S3 in Remote position and be sure remote control is connected to Remote receptacle RC1 (see Section 3-8).
	Check position of Preflow Time control R12.
	Check continuity of Preflow Time switch S9. Check condition of contacts. Repair or replace S9 if necessary.
	Remove jumper link 1 on terminal strip 1T.
	Check optional preflow timer board TD3, and replace if necessary.
Optional spot timer relay TD2 does not time out.	Place Spot Time switch S8 in the On position.
	Remove jumper link 2 from terminal strip 1T.
	Place Spot Time control R10 in desired position.
	Check coil voltage and connections of spot timer relay TD2. Check continuity of coil and condition of contacts. Replace TD2 if necessary.
	Check coil voltage and connections of control relay CR3. Check continuity of coil and condition of contacts. Replace CR3 if necessary.
	Check coil voltage and connections of control relay CR1. Check continuity of coil and condition of contacts. Replace CR1 if necessary.
Postflow timer does not time out.	Check position of Postflow Time control setting (see Section 4-10).
	Check Control relay CR5 contacts 2 and 5 for proper operation. Replace CR5 if necessary.
	Check coil voltage and connections of gas valve GS1. Check continuity of coils. Replace GS1 if necessary.
	Check input voltage and connections to Postflow timer board TD1. Check continuity of contacts. Replace TD1 if necessary.
	Check control board PC1 and connections, and replace if necessary.
No postflow time.	Check position of Postflow Time control setting (see Section 4-10).
	Place Output(Contactor) switch S3 in the Remote position, and connect a remote control to receptacle RC1 according to Section 3-8.
	Check coil voltage and connections of control relay CR5. Check continuity of coil and condition of contacts. Replace CR5 if necessary.
	Check coil voltage and connections of gas valve GS1. Check continuity of coils. Replace GS1 if necessary.
	Check input voltage and connections to Postflow timer board TD1. Check continuity of contacts. Replace TD1 if necessary.
	Check control board PC1 and connections, and replace if necessary.
No gas flow.	Place Output(Contactor) switch S3 in the Remote position, and connect a remote control to receptacle RC1 according to Section 3-8.
	Check circuit breaker CB1, and reset if open (see Section 7-2).

Trouble	Remedy
	<p>Check Control relay CR2 contacts 4 and 7 for proper operation. Replace CR2 if necessary.</p> <p>Check coil voltage and connections of gas valve GS1. Check continuity of coils. Replace GS1 if necessary.</p>
No power output at 115 volts ac receptacle RC1; weld output available.	Check circuit breaker CB1, and reset if open (see Section 7-2).
Fan motor FM does not run; weld output available. Effective with Serial No. KG164875, unit is equipped with Fan-On-Demand, which only runs when cooling is required.	<p>Check and clear fan blade obstruction.</p> <p>Check coil voltage and connections of fan motor FM, and replace if necessary.</p>
Line fuse opens immediately when solid-state contactor SR1 turns on in DC mode only.	<p>Check diode D1, and replace if necessary.</p> <p>Check SCRs in main rectifier SR1, and replace if necessary. If any SCRs are replaced, Check capacitors C7 through C10 for a short or open, and check for proper connections. Replace C7 through C10 if necessary.</p>
No control of weld output.	<p>Check position of Amperage Control switch S5 (see Section 4-7).</p> <p>Check resistance and connections of Amperage Adjustment control R1; R1 is 1000 ohms $\pm 10\%$. Replace R1 if necessary.</p> <p>Check, repair or replace remote control device.</p> <p>Effective with Serial No. KB110695, check resistance and connections of HD1; HD1 is 1600 ohms $\pm 10\%$ between pins 1 and 3 of plug PLG3. Check input and output voltages. Replace HD1 if necessary.</p> <p>Check control board PC1 and connections, and replace if necessary.</p>
Tungsten electrode oxidizing and not remaining bright after conclusion of weld.	<p>Check position of Postflow Time control R12 (see Section 4-10).</p> <p>Check and tighten all gas fittings if necessary.</p> <p>Increase gas flow setting.</p> <p>Shield weld zone from drafts.</p> <p>Properly prepare tungsten.</p> <p>Place High Frequency switch S2 in Start or Continuous position.</p>
Wandering arc - poor control of direction of arc.	<p>Use proper size tungsten for welding application.</p> <p>Properly prepare tungsten.</p>
Controls connected to Remote 14 receptacle RC1 do not work properly.	<p>Check, repair or replace remote control device.</p> <p>Check Amperage Control switch S5 position (see Section 4-7). Check and replace S5 if necessary.</p> <p>Check Output (Contactor) switch S3 position (see Section 4-8). Check and replace S3 if necessary.</p> <p>Check position of jumper links 1 and 2 on terminal strip 1T according to Section 6-2.</p> <p>Check coil voltage and connections of control relay CR2. Check continuity of coil and condition of contacts. Replace CR2 if necessary.</p> <p>Prior to Serial No. KF959379, check choke RFC1 connections. Check continuity of RFC1. Replace if necessary. Effective with Serial No. KF959379 check remote 14 filter board PC2 (see Section 6-6). Replace PC2 if necessary.</p> <p>Check control board PC1 and connections, and replace if necessary.</p>
Ammeter A1 not displaying correct weld output amperage.	<p>Calibrate ammeter as instructed in Section 6-8.</p> <p>Check ammeter A1 voltage; +1 millivolts dc per 3 ampere of weld output. Replace A1 if necessary.</p> <p>Check control board PC1 and connections, and replace if necessary.</p> <p>Effective with Serial No. KB110695, check resistance and connections of hall device HD1; HD1 is 1600 ohms $\pm 10\%$ between pins 1 and 3 of plug PLG3. Check input and output voltages. Replace HD1 if necessary.</p>
Voltmeter V1 not displaying correct arc voltage.	Check connections for continuity to voltmeter V1. Replace V1 if necessary.
Electronic equipment in welding area not working properly.	HF interference problem. Check for proper installation, and correct problem (see Section 8).

6-2. Troubleshooting Circuit Diagram For Welding Power Source

- ▲ Disable high frequency by placing High Frequency switch S2 in Off position before testing unit.

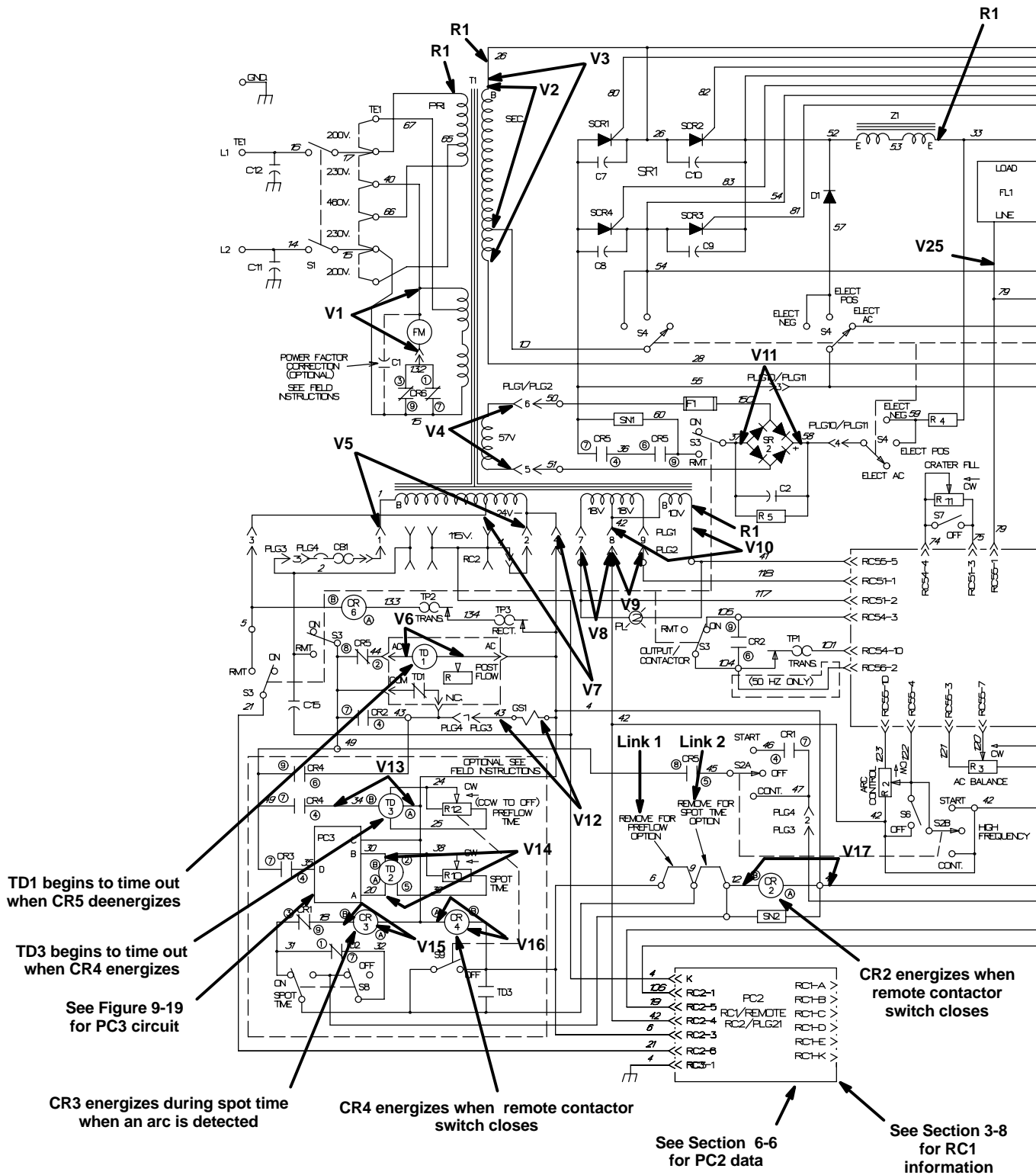

Test Equipment Needed:

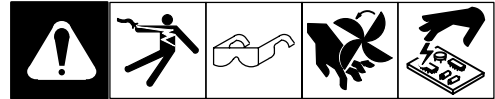
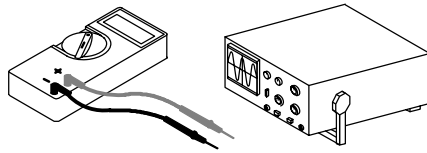

Voltage Readings

- a) Tolerance – $\pm 10\%$ unless specified
- b) Reference – to circuit common (lead 42) unless noted
- c) Wiring Diagram – see Section 10

V1	230 volts ac
V2	77 volts ac
V3	82.5 volts ac
V4	57 volts ac
V5, V6	115 volts ac
V7	24 volts ac
V8, V9	18 volts ac
V10	10 volts ac
V11	80 volts dc
V12, V13, V14	115 volts ac
V15, V16, V17	24 volts ac
V18	115 volts ac with S2 in Start or Continuous
V19	0 to +10 volts dc with contactor on
V20, V21	24 volts dc
V22	0-80 volts dc (rectified arc voltage)
V23	maximum 80 volts ac/dc
V24	24 volts dc
V25	16.5 millivolts dc per 1 ampere of weld output

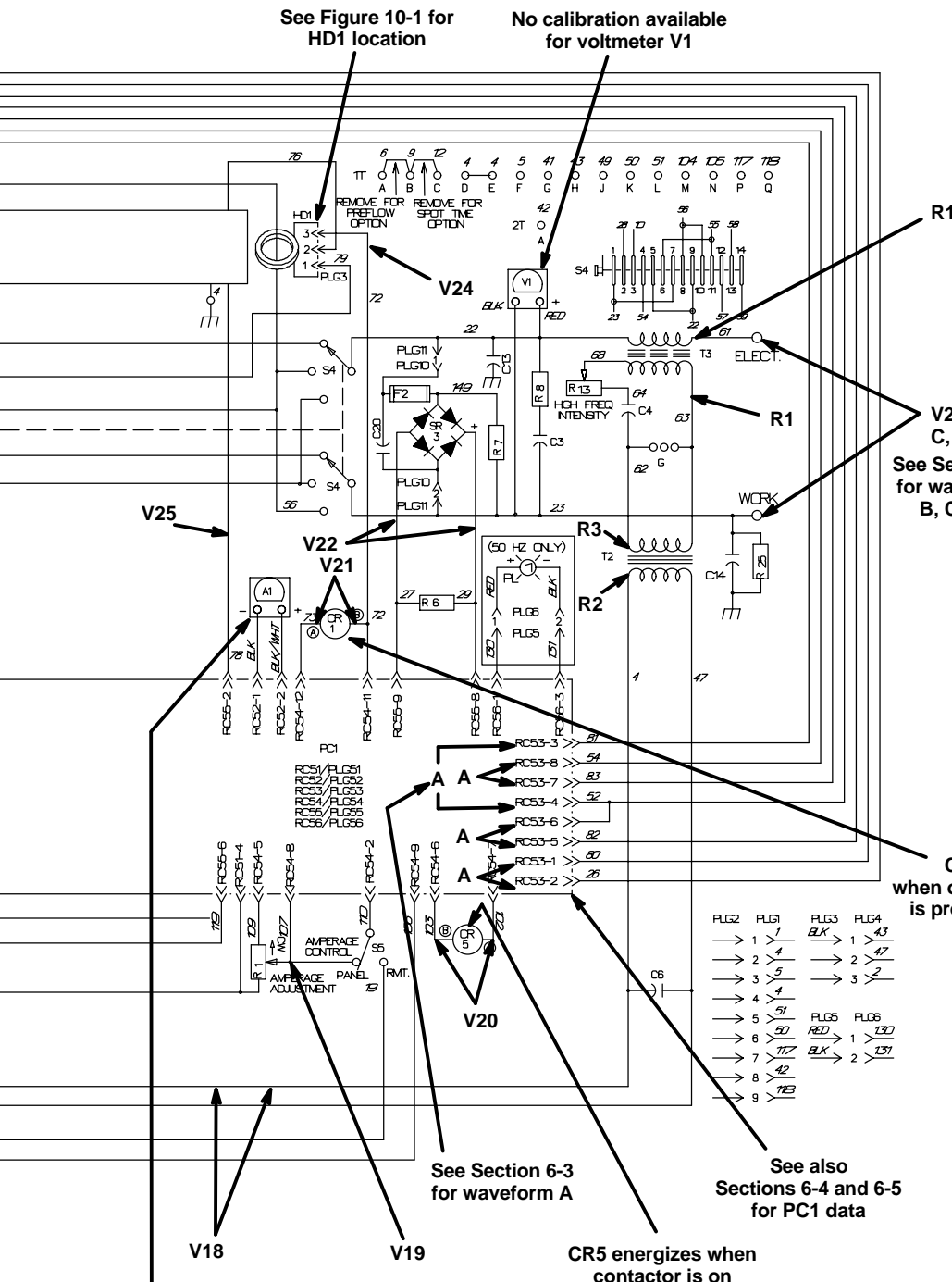

See Figure 10-1 for HD1 location

No calibration available for voltmeter V1

See Section 6-3 for waveforms B, C, D, E

See Section 6-3 for waveform A

See also Sections 6-4 and 6-5 for PC1 data

CR1 energizes when open-circuit voltage is present; deenergizes when an arc is struck

CR5 energizes when contactor is on

See Section 6-8 for ammeter A1 calibration

Resistance Values

- a) Tolerance – $\pm 10\%$ unless specified
- b) Turn Off unit and disconnect input power before checking resistance

R1	All values for T1, Z1, and T3 are less than 1 ohm
R2	5.3 ohms
R3	6.1 K ohms

6-3. Waveforms For Section 6-2



Waveforms shown are for 60 Hertz models;
waveforms for 50 Hertz models are similar.

5 ms 1 V

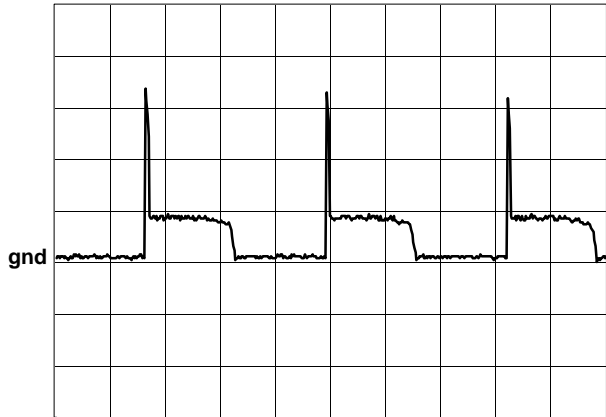

A. SR1 Gate Pulse With Respect To Cathode At No Load

5 ms 50 V

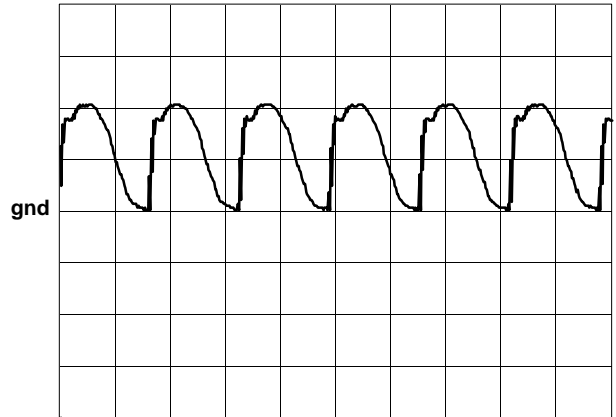

B. DC Open-Circuit Voltage With Amperage Adjustment Control At Maximum

5 ms 20 V

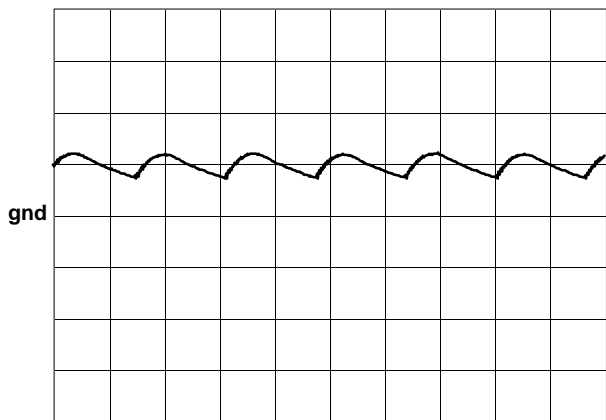

C. DC Output, 100 Amperes, 24 Volts DC (Resistive Load)

5 ms 50 V

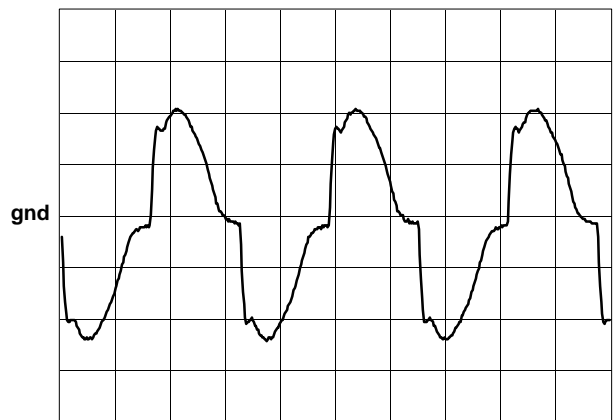

D. AC Open-Circuit Voltage With Amperage Adjustment Control At Maximum

5 ms 50 V

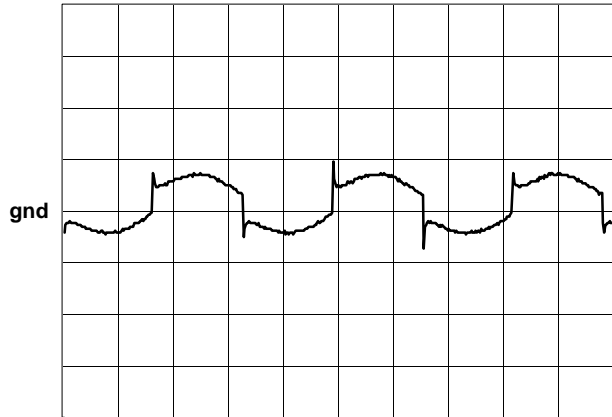

E. AC Output, 100 Amperes, 24 Volts AC (Resistive Load)



Test Equipment Needed:

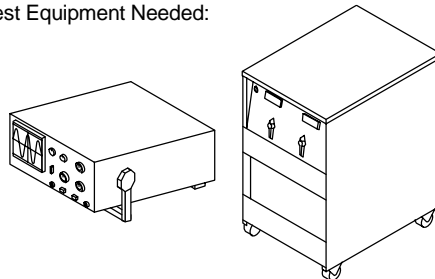

6-4. Control Board PC1 Testing Information (Use With Section 6-5)

▲ **Disable high frequency by placing High Frequency switch S2 in Off position before testing unit.**

Be sure plugs are secure before testing. See Section 6-5 for specific values during testing.

- 1 Control Board PC1
- 2 Receptacle RC51
- 3 Receptacle RC52
- 4 Receptacle RC53
- 5 Receptacle RC54
- 6 Receptacle RC55

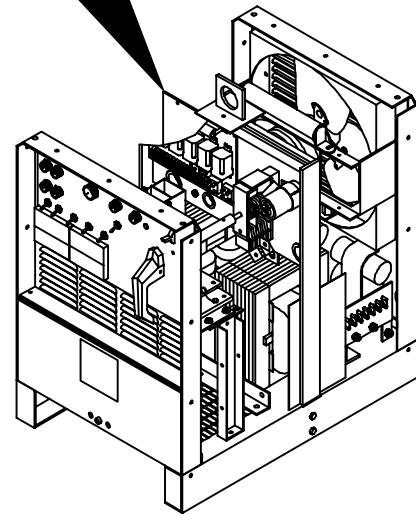
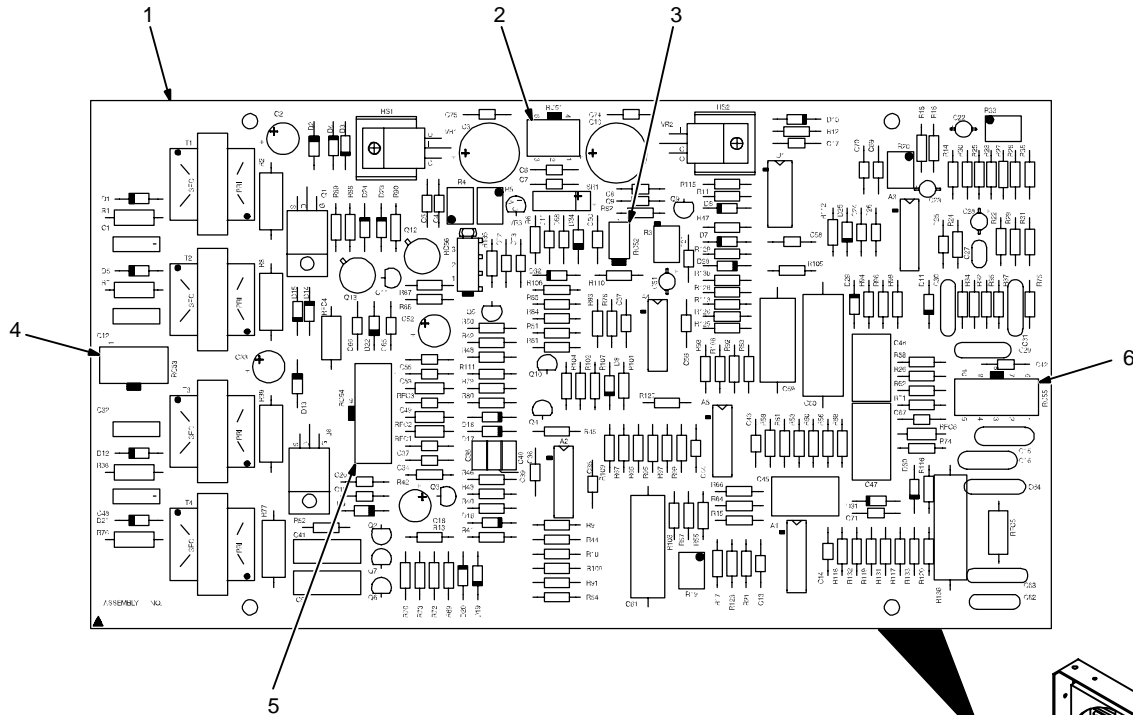

Test Equipment Needed:

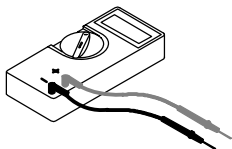

SB-178 976-A / ST-800 344-A

6-5. Control Board PC1 Test Point Values

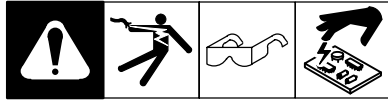

PC1 Voltage Readings

- a) Tolerance - $\pm 10\%$ unless specified
- b) Reference - to circuit common (lead 42) unless noted

Receptacle	Pin	Value
RC51	1	18 volts ac input
	2	18 volts ac input
	3	+10 volts dc output
	4	Circuit common
	5	Not used
	6	Not used
RC52	1	Circuit common
	2	+1 millivolt dc per 3 ampere of weld output
RC53	1	Gate pulse for SCR1 with respect to pin 2 (see Section 6-3)
	2	Reference for gate pulse to SCR1
	3	Gate pulse for SCR3 with respect to pin 4 (see Section 6-3)
	4	Reference for gate pulse to SCR3
	5	Gate pulse for SCR2 with respect to pin 6 (see Section 6-3)
	6	Reference for gate pulse to SCR2
	7	Gate pulse for SCR4 with respect to pin 8 (see Section 6-3)
	8	Reference for gate pulse to SCR4
RC54	1	Not used
	2	0 to +10 volts dc input from min. to max. of Amperage Adjustment control R1 with Amperage Control switch S5 in Panel position, and contactor on
	3	0 volts with Output (Contactor) switch S3 in On position or +7.8 volts dc with S3 in Remote position
	4	0 to +10 volts dc input from min. to max. of Crater Control R11 with Crater Fill switch S7 in On position, or +10 volts dc with S7 in Off position
	5	+10 volts dc output with Output (Contactor) switch S3 in On position
	6	-24 volts dc
	7	-24 volts dc with contactor on or off
	8	0 to +10 volts dc input from min. to max. of Amperage Adjustment control R1 with contactor on
	9	0 to +10 volts dc input from min. to max. of Amperage Adjustment control R1 with contactor on
	10	Circuit common
	11	+24 volts dc
	12	0 volts during open-circuit voltage condition; +24 volts with arc on or contactor off

Receptacle	Pin	Value
RC55	1	Circuit common
	2	+1.65 volts dc per 100 amperes of weld output with respect to pin 1
	3	-15 volts dc output
	4	0 to +4 volts dc input from min. to max. of Arc Control R2 with Arc Control switch S6 On
	5	10 volts ac input for synchronization
	6	+5.8 volts dc output
	7	-15 volts dc input from Max. Penetration setting of AC Balance control R3 to +5.8 volts dc input at Max. Cleaning setting of R3
	8	0 to 80 volts dc voltage feedback signal (rectified arc voltage) with respect to pin 9
	9	0 to 80 volts dc voltage feedback signal (rectified arc voltage) with respect to pin 8
	10	0 to +4 volts dc input from min. to max. of Arc Control R2 with Arc Control switch S6 Off

6-6. Remote Board PC2 Testing Information (Use With Section 6-7)

▲ Disable high frequency by placing High Frequency switch S2 in Off position before testing unit.

Be sure plugs are secure before testing. See Section 6-7 for specific values during testing.

- 1 Remote 14 Filter Board PC2
 - 2 Remote 14 receptacle RC1
- See Section 3-8 for information.
- 3 Receptacle RC2
 - 4 Receptacle RC3

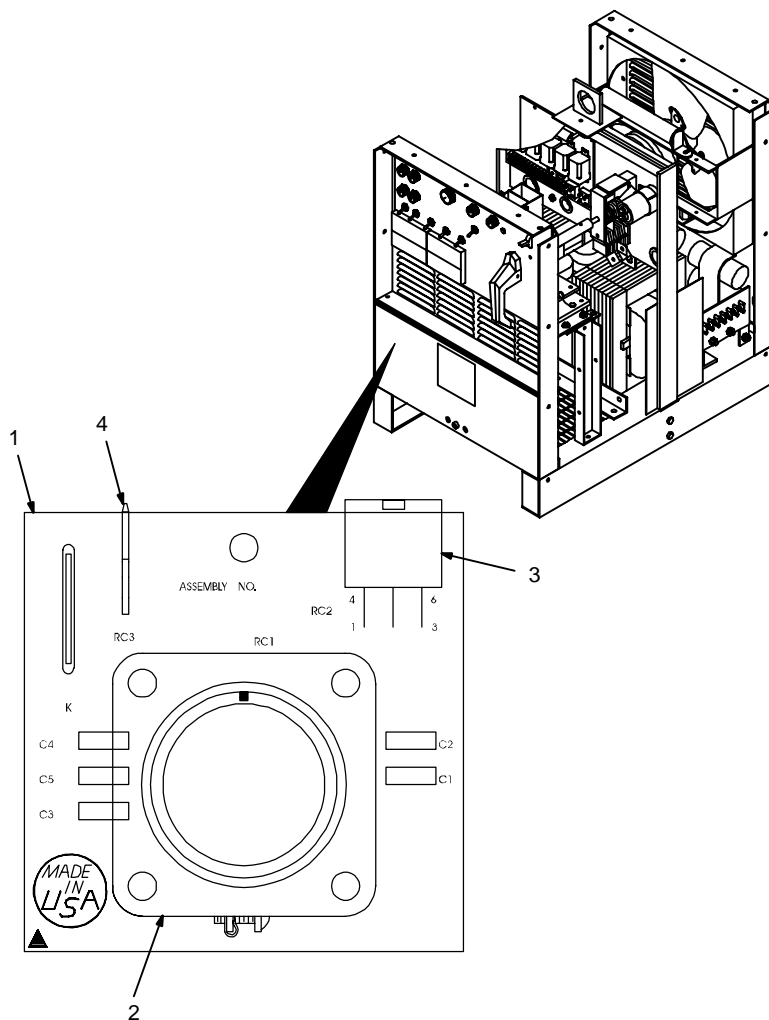

Test Equipment Needed:

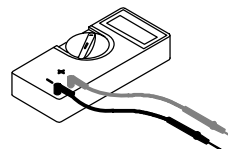

6-7. Remote 14 Filter Board PC2 Test Point Values (Use With Section 6-2 And Section 6-6)

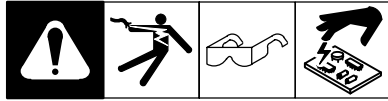

PC2 Voltage Readings

- a) Tolerance - $\pm 10\%$ unless specified
- b) Reference - to circuit common (lead 42) unless noted

Receptacle	Pin	Value
RC1	A	24 volts ac
	B	Contact closure to A completes 24 volts ac contactor control circuit
	C	Command reference; 0 to +10 volts dc output to remote control
	D	Remote control circuit common
	E	0 to +10 volts dc input command signal from remote control
	K	Chassis common
RC2	1	Command reference; 0 to +10 volts dc output to remote control
	3	Contact closure to A completes 24 volts ac contactor control circuit
	4	Remote control circuit common
	5	0 to +10 volts dc input command signal from remote control
	6	24 volts ac
RC3	1	Chassis common

6-8. Meter Calibration

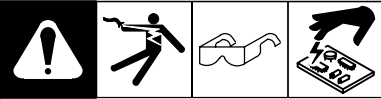

Be sure plugs are secure before calibrating meter.

- 1 Control Board PC1
- 2 Voltmeter V1
- 3 Ammeter A1

 No calibration available for ammeter offset, or for voltmeter V1.

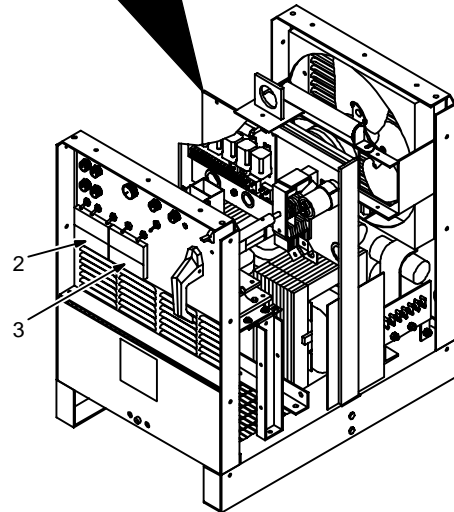
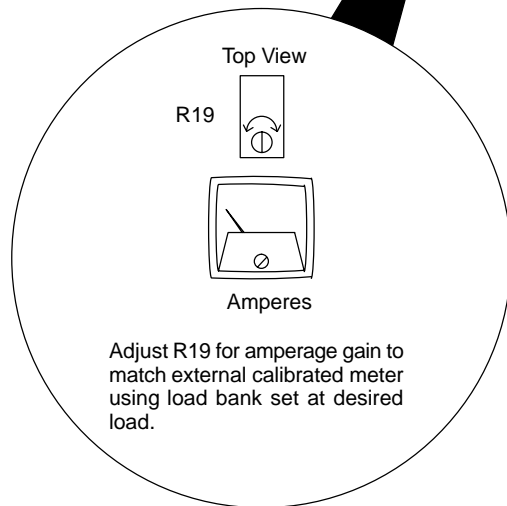
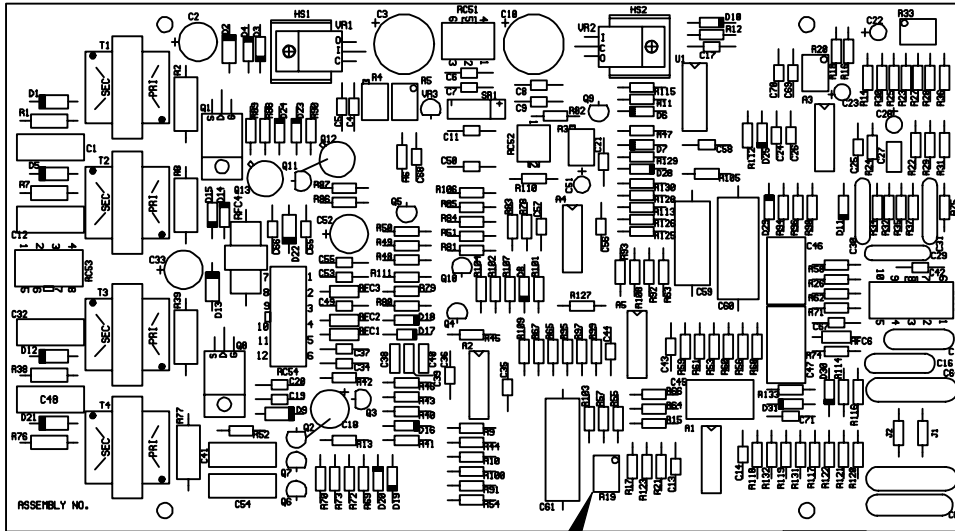

SB-130 690-D / ST-800 344-A

6-9. Input Voltage Labels And Connections







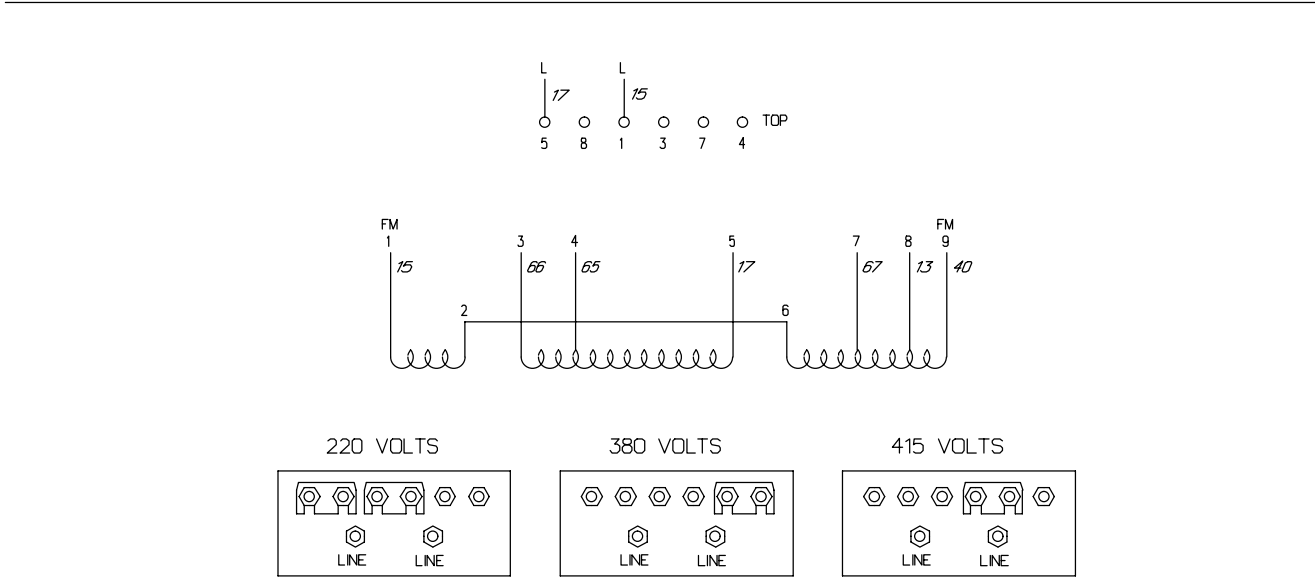
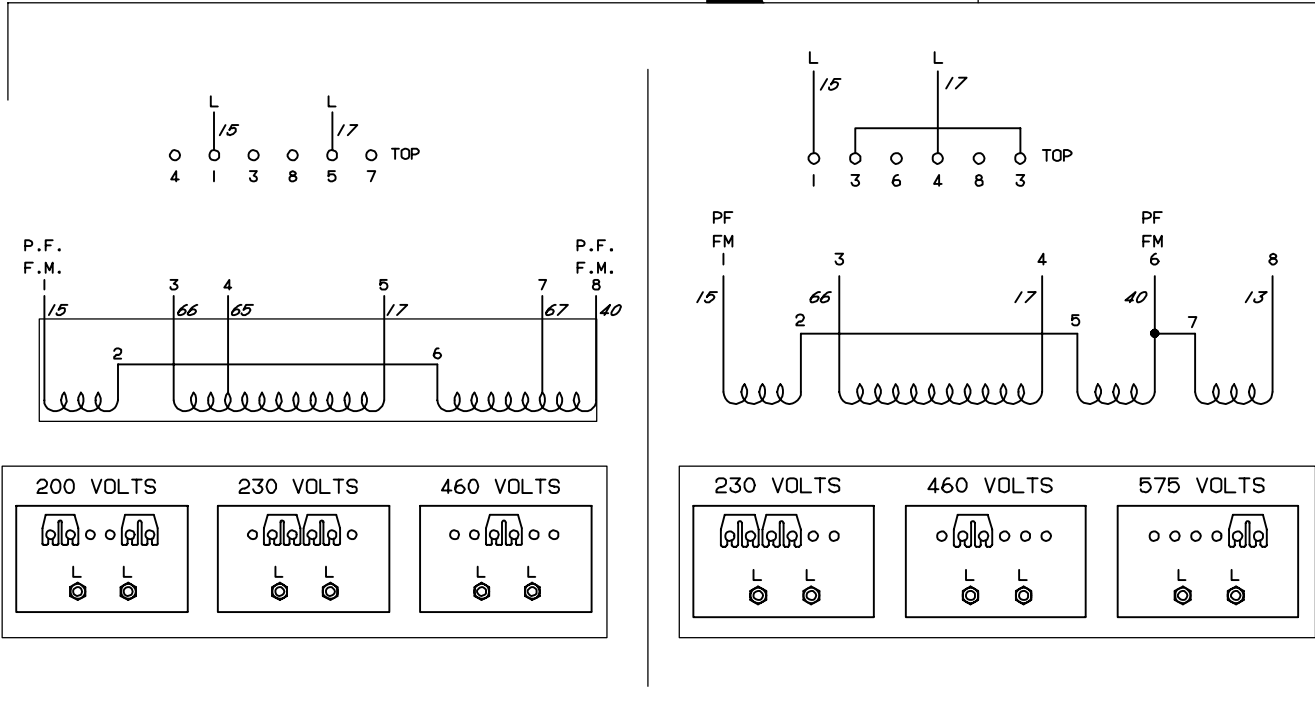
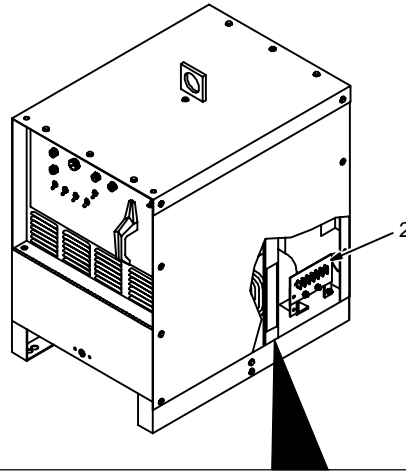
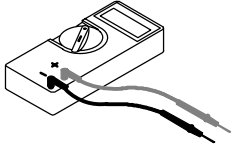

- 1 Input Voltage Label And Connection Diagram – Only One Label Is On Unit
- 2 Terminal Strip TE1

Test Equipment Needed:

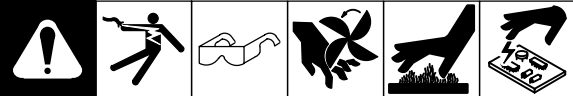

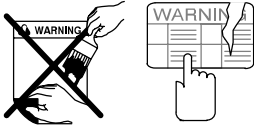
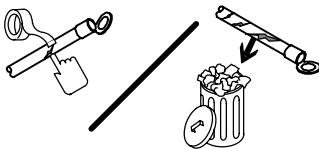
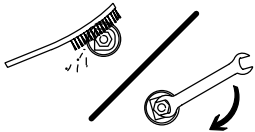
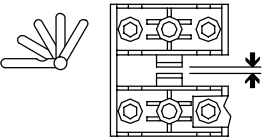
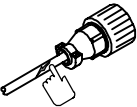
SECTION 7 – MAINTENANCE

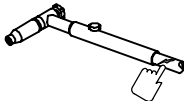
7-1. Routine Maintenance

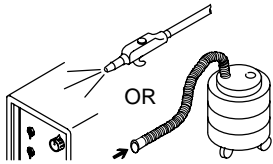
					<p>▲ Disconnect power before maintaining.</p>				
 3 Months									
 <p>Replace Unreadable Labels</p>			 <p>Repair Or Replace Cracked Weld Cables</p>			 <p>Clean And Tighten Weld Terminals</p>			
 <p>Adjust Spark Gaps</p>			 <p>14-Pin Cord</p>		 <p>Gas Hose</p>		 <p>Torch Cable</p>		<p>Replace Cracked Parts</p>
 6 Months									
 <p>OR</p>					<p>Blow Out Or Vacuum Inside, During Heavy Service, Clean Monthly</p>				

7-2. Circuit Breaker CB1

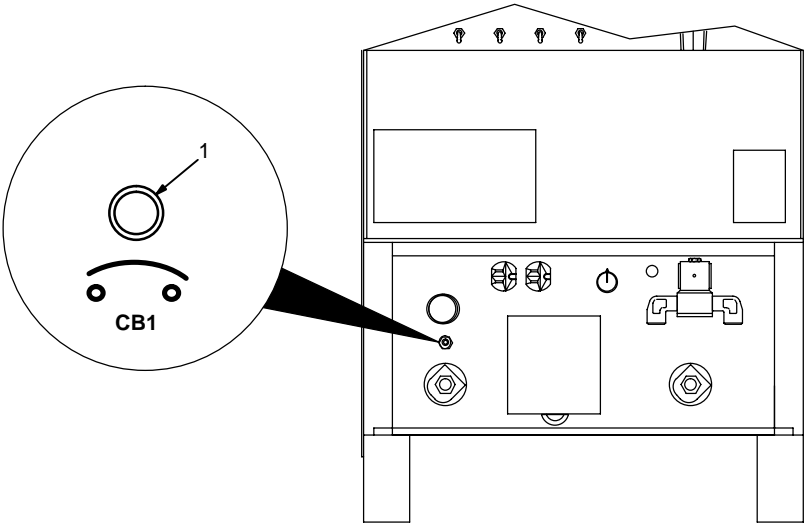
		<p>1 Circuit Breaker CB1</p> <p>If CB1 opens, output to the 115 volts ac duplex receptacle, high frequency, and gas flow stop. Press button to reset breaker.</p>	
			

Ref. ST-154 795-C

7-3. Fuses F1 And F2

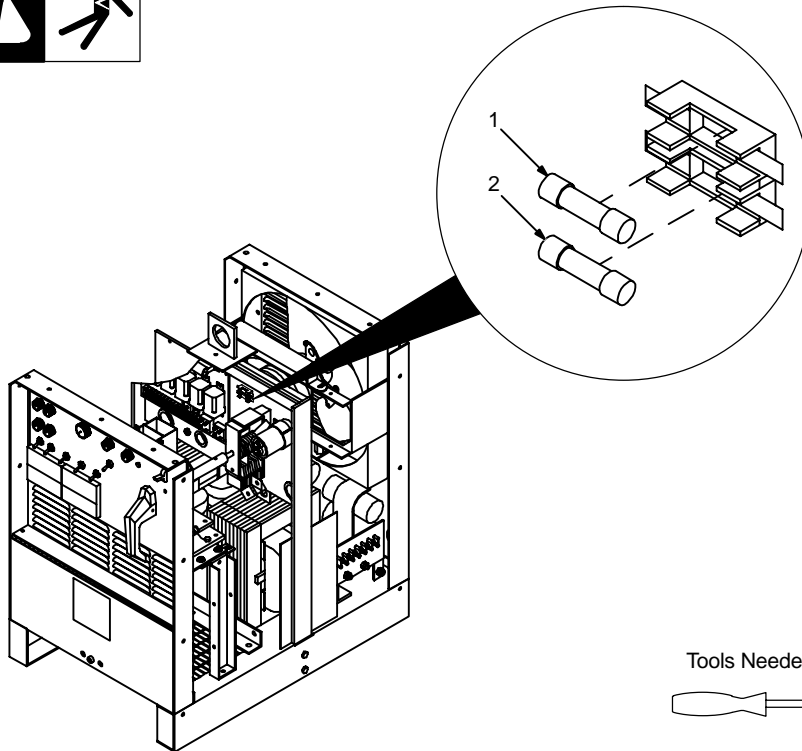

1 Fuse F1 (See Parts List For Rating)

Fuse F1 (between leads 50 and 150) protects wiring harness from shorted SR2. If F1 opens, you may experience problems with arc starting and arc performance in the DC TIG mode.

2 Fuse F2 (See Parts List For Rating)

Fuse F2 (between leads 22 and 149) protects wiring harness from shorted SR3. If F2 opens, you may experience problems with arc control, and no high frequency in start high frequency.

Tools Needed:

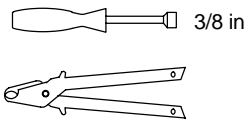

7-4. Adjusting Spark Gaps

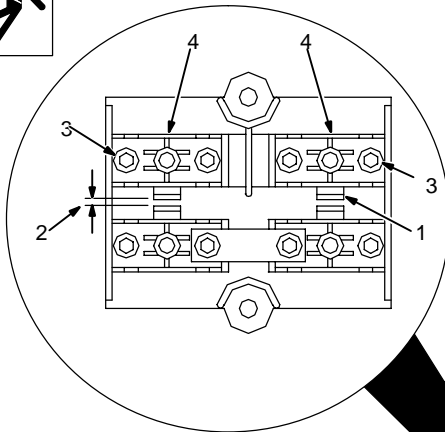

▲ Turn Off power before adjusting spark gaps.

Open access door.

1 Tungsten End Of Point

Replace point if tungsten end disappears; do not clean or dress tungsten.

2 Spark Gap

Normal spark gap is 0.008 in (0.203 mm).

If adjustment is needed, proceed as follows:

3 Adjustment Screws

Loosen screws. Place gauge of proper thickness in spark gap.

4 Pressure Point

Apply slight pressure at point until gauge is held firmly in gap. Tighten screws to 12 in/lbs torque (overtightening will deform plastic base). Adjust other gap.

Close access door.

Tools Needed:

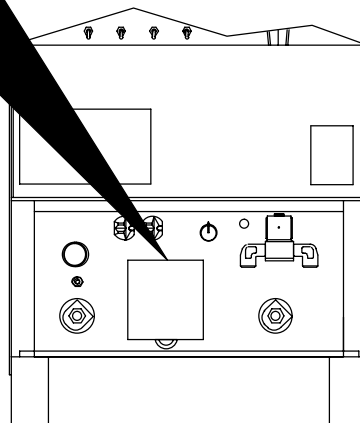
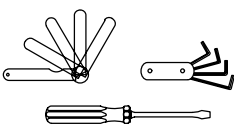

Ref. ST-154 795-C / Ref. S-0043

SECTION 8 – HIGH FREQUENCY (HF)

8-1. Welding Processes Using HF

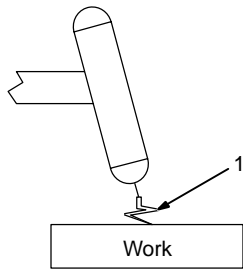

Gas Tungsten Arc Welding (GTAW)

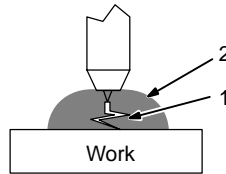

Submerged Arc Welding (SAW)

1 HF Voltage

GTAW – helps arc jump air gap between torch and workpiece and/or stabilize the arc.

SAW – helps arc reach workpiece through flux granules.

2 Flux

high_freq1 7/95 – S-0693

8-2. Sources Of HF Radiation From Incorrect Installation

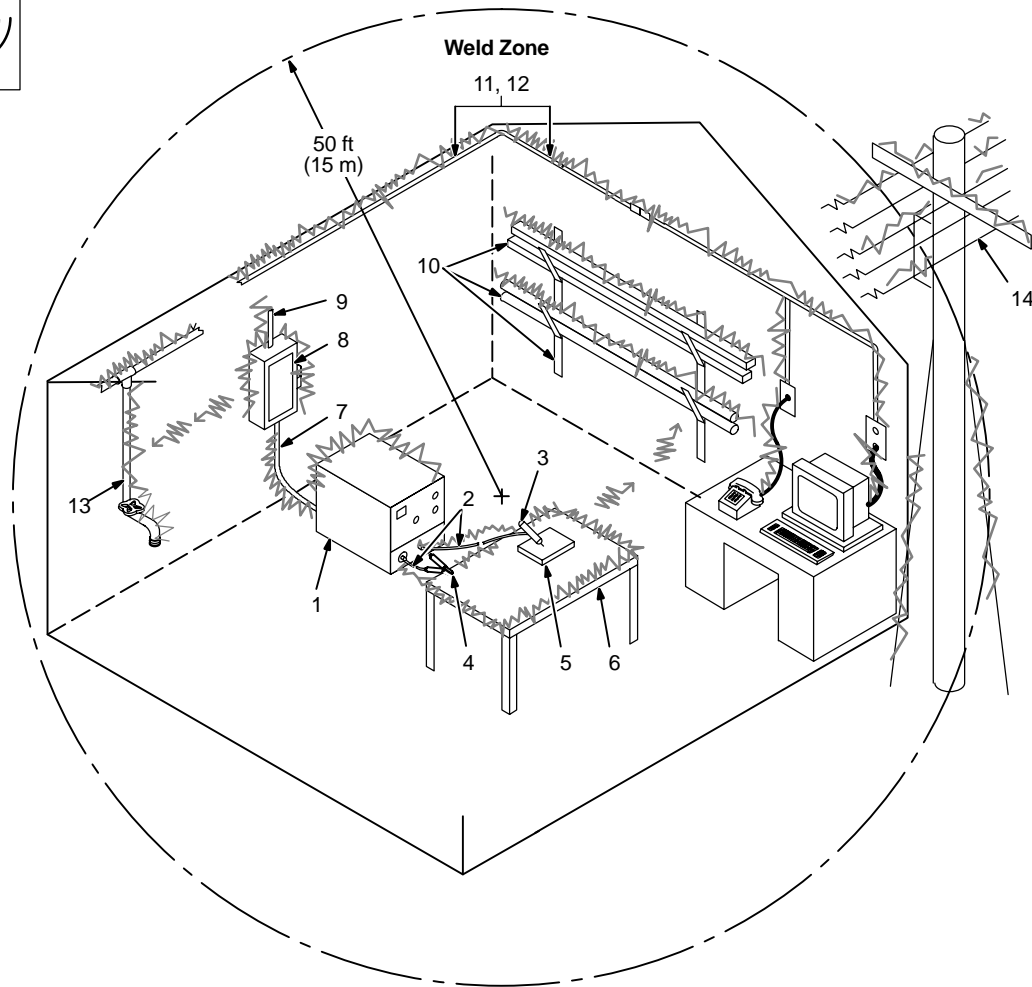

S-0694

Sources Of Direct HF Radiation

- 1 HF source (welding power source with built-in HF or separate HF unit)
- 2 Weld Cables
- 3 Torch
- 4 Work Clamp

5 Workpiece

6 Work Table

Sources Of Conduction Of HF

- 7 Input Power Cable
- 8 Line Disconnect Device
- 9 Input Supply Wiring

Sources Of Reradiation Of HF

- 10 Ungrounded Metal Objects
- 11 Lighting
- 12 Wiring
- 13 Water Pipes And Fixtures
- 14 External Phone And Power Lines

8-3. Correct Installation

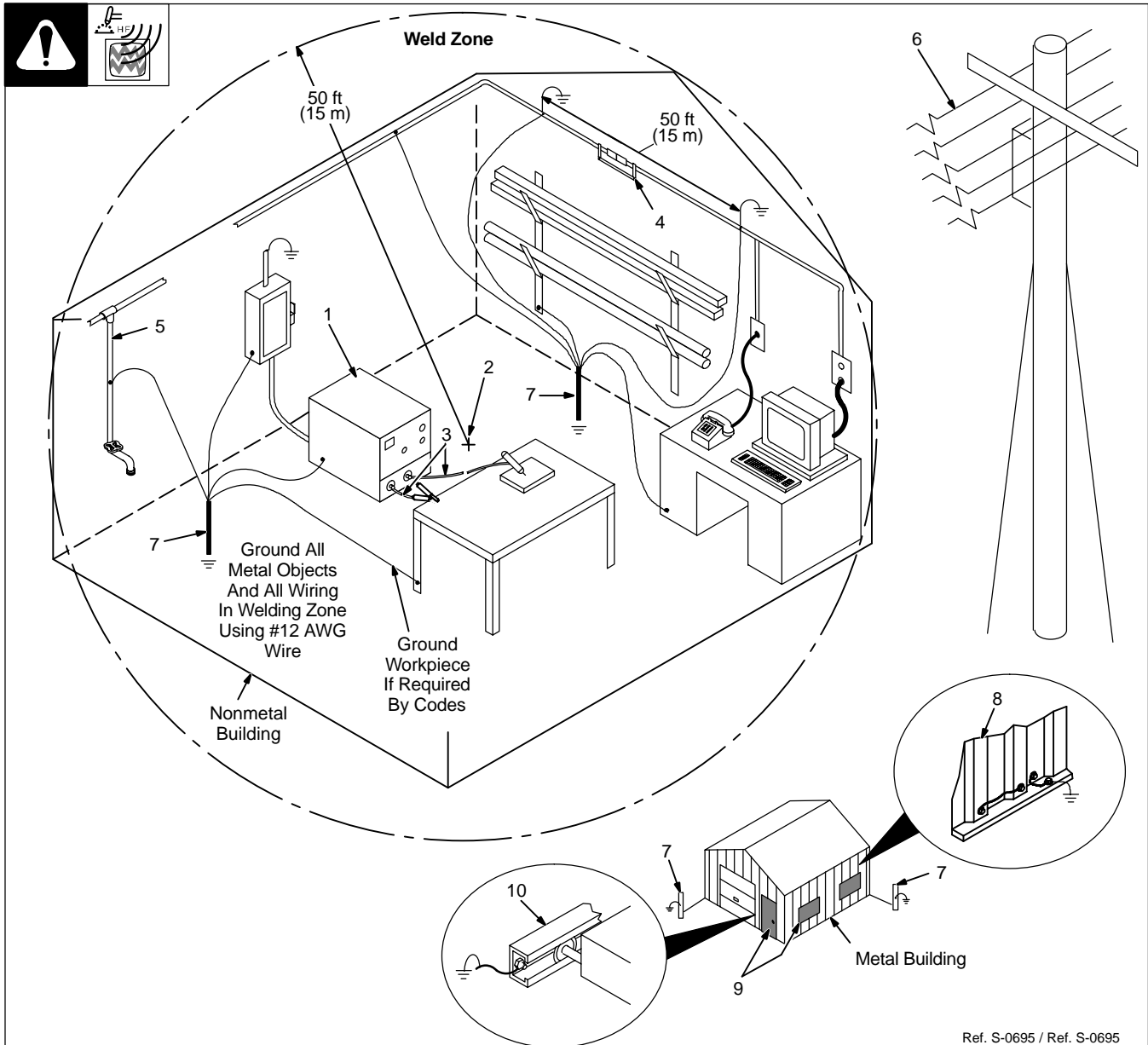

Ref. S-0695 / Ref. S-0695

- 1 HF Source (Welder With Built-In HF Or Separate HF Unit)
Ground metal machine case, work output terminal, line disconnect device, input supply, and worktable.
- 2 Welding Zone And Centerpoint
A circle 50 ft (15 m) from centerpoint between HF source and welding torch in all directions.
- 3 Weld Output Cables
Keep cables short and close together.
- 4 Conduit Joint Bonding And Grounding

- Electrically join (bond) all conduit sections using copper straps or braided wire. Ground conduit every 50 ft (15 m).
- 5 Water Pipes And Fixtures
Ground water pipes every 50 ft (15 m).
- 6 External Power Or Telephone Lines
Locate HF source at least 50 ft (15 m) away from power and phone lines.
- 7 Grounding Rod
Consult the National Electrical Code for specifications.

- 8 Metal Building Panel Bonding Methods
Bolt or weld building panels together, install copper straps or braided wire across seams, and ground frame.
- 9 Windows And Doorways
Cover all windows and doorways with grounded copper screen of not more than 1/4 in (6.4 mm) mesh.
- 10 Overhead Door Track
Ground the track.

SECTION 9 – ELECTRICAL DIAGRAMS

 The circuits in this manual can be used for troubleshooting, but there might be minor circuit differences from your machine. Use circuit inside machine case or contact distributor for more information.

The following is a list of all diagrams for models covered by this manual.

Model	Serial Or Style Number	Circuit Diagram	Wiring Diagram
Syncrowave 250	JJ339876 thru JJ351864	SC-114 914	D-116 884-B♦♦
	JJ351865 thru JJ365633	SC-120 877	D-120 878-B♦♦
	JJ365634 thru JJ503983	SC-121 280	D-121 281-D♦♦
	JJ503984 thru JK572897	SC-124 314	D-124 307-C♦♦
	JK572898 thru JK617846	SC-124 785-B	D-124 786-B♦♦
	JK617847 thru JK682713	SC-124 785-B	D-129 200-B♦♦
	JK682714 thru JK690986	SC-124 785-B	D-130 576-B♦♦
	JK690987 thru KA806712	SC-132 697-A	D-132 431-D♦♦
	KA806713 thru KA877024	SC-137 431	D-137 430-A♦♦
	KA877025 thru KB010829	SC-135 581	D-135 734-A♦♦
	KB010830 thru KB110694	SC-142 524	D-142 525-A♦♦
	KB110695 thru KC252675	SC-148 144	D-148 145-A♦♦
	KC252676 thru KG029204	SC-154 649-C	D-154 648-E♦♦
	KG029205 thru KG062109	SC-178 835	D-174 039-A♦♦
	KG062110 thru KG170300	SC-179 303-A	D-179 305-A♦♦
KG170301 thru KH526230	SC-181 109-E	SD-181 110-F♦♦	
KH526231 and following	SC-188 161-A	SD-188162-A	
Circuit Board PC1	JJ339876 thru JJ399987	D-118 765♦♦	
	JJ399988 thru JK682713	D-122 270♦♦	
	JK682714 thru KA797306	D-130 691-A♦♦	
	KA797307 thru KG062109	D-135 253♦♦	
	KG062110 thru KH508254	SD-178 975♦♦	
	KH508255 and following	SD-187644	
RFC Circuit Board PC2	JJ365634 thru KB010829	SA-121 282	
Remote 14 Filter Board PC2	KF959379 and following	SA-158 763	
Circuit Board PC3♦	JJ351865 and following	SA-120 872	
Timer TD1	JJ339876 and following	SA-044 725-C	
Timer TD3♦	JJ339876 and following	SA-045 288-D	
♦ Optional ♦♦ Not included in this manual			

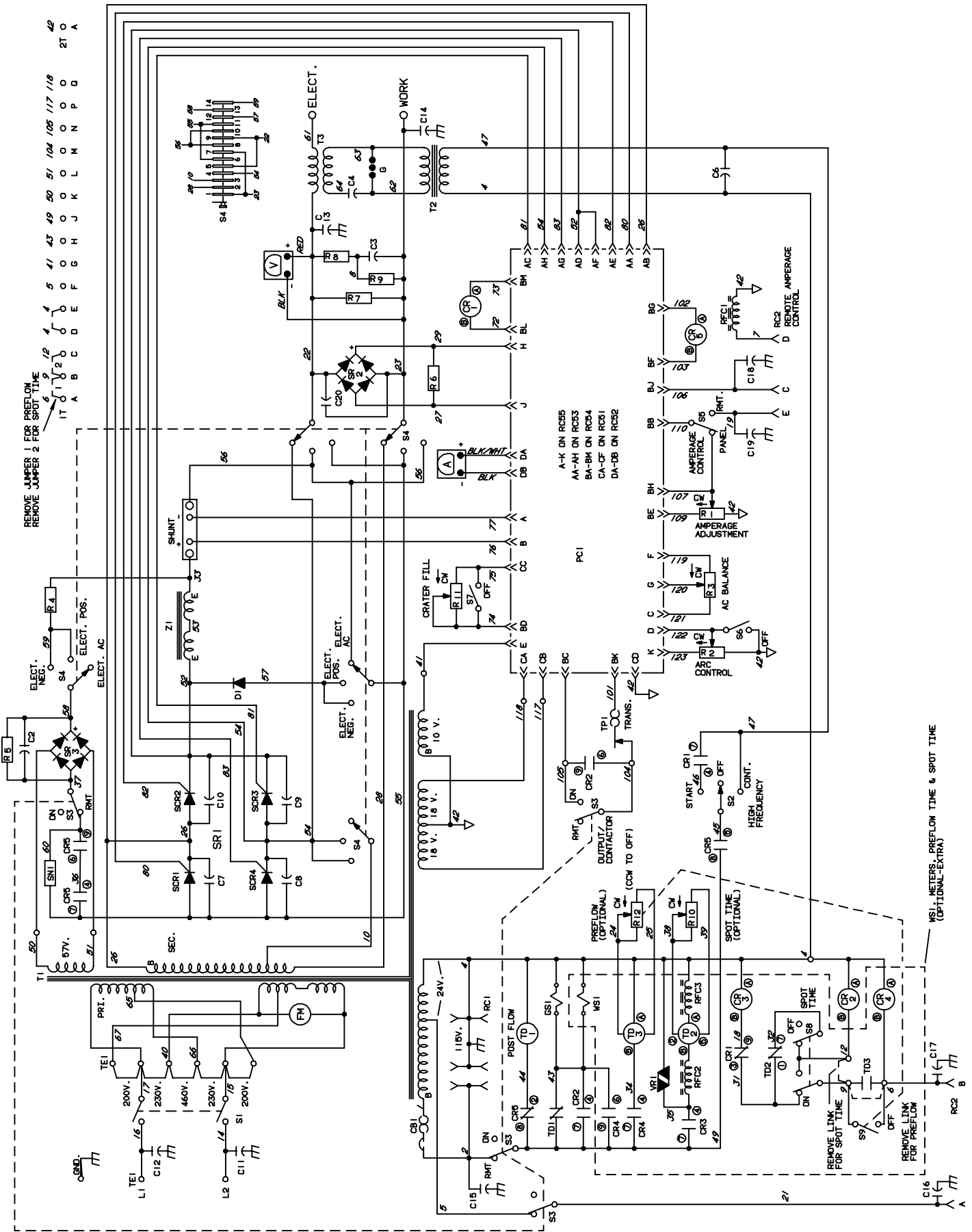
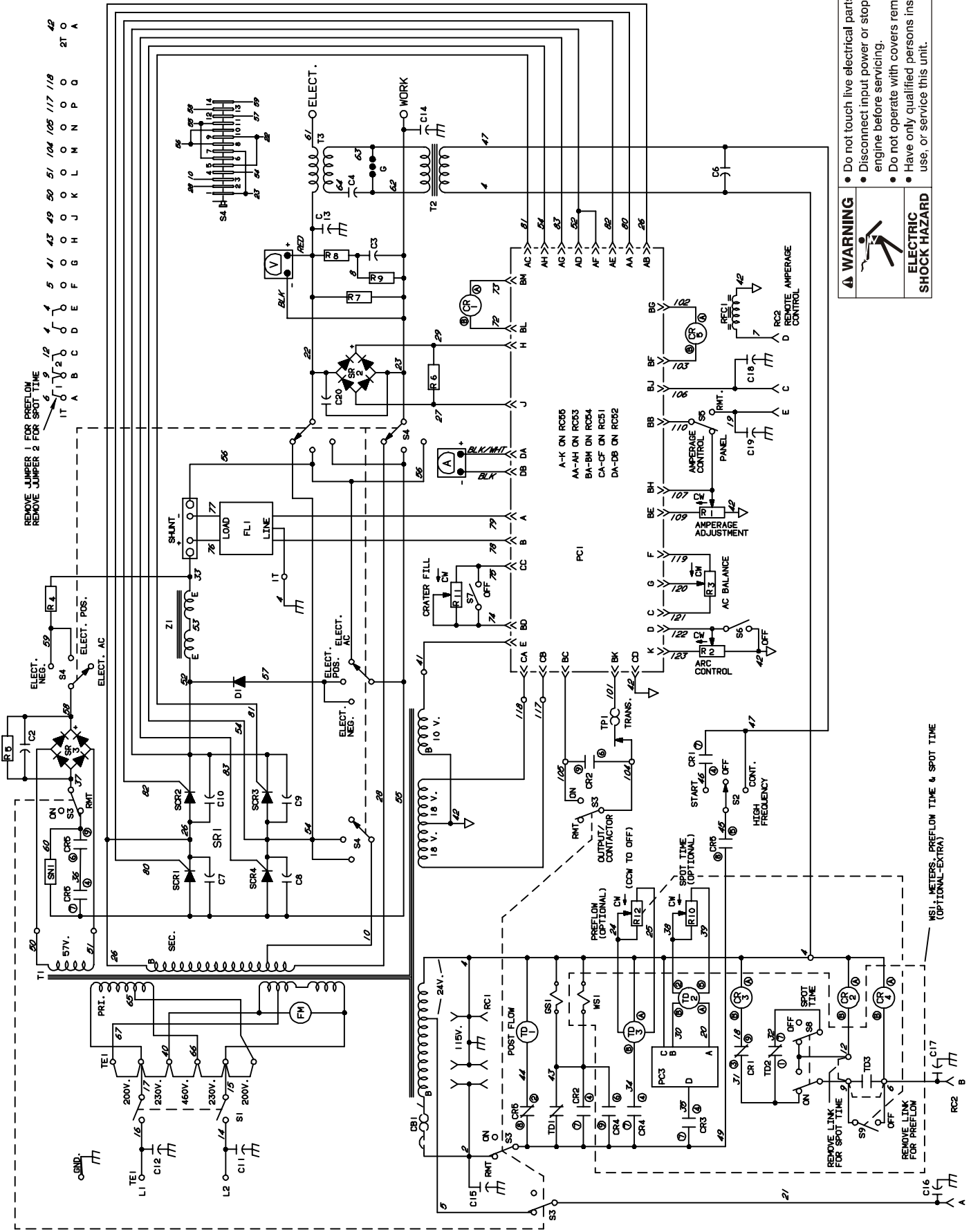

Figure 9-1. Circuit Diagram For Syncrowave 250 Effective With Serial No. JJ339876 Thru JJ351864
 TM-353 Page 42
 SC-114 914
 Syncrowave 250



REMOVE JUMPER 1 FOR PREFLON ON
REMOVE JUMPER 2 FOR SPOT TIME

IT 1 2 3 4 5 6 7 8 9 10 11 12
A B C D E F G H J K L M N P O 42

WARNING

- Do not touch live electrical parts.
- Disconnect input power or stop engine before servicing.
- Do not operate with covers removed.
- Have only qualified persons install, use, or service this unit.

ELECTRIC SHOCK HAZARD

Figure 9-2. Circuit Diagram For Syncrowave 250 Effective With Serial No. JJ351865 Thru JJ365633

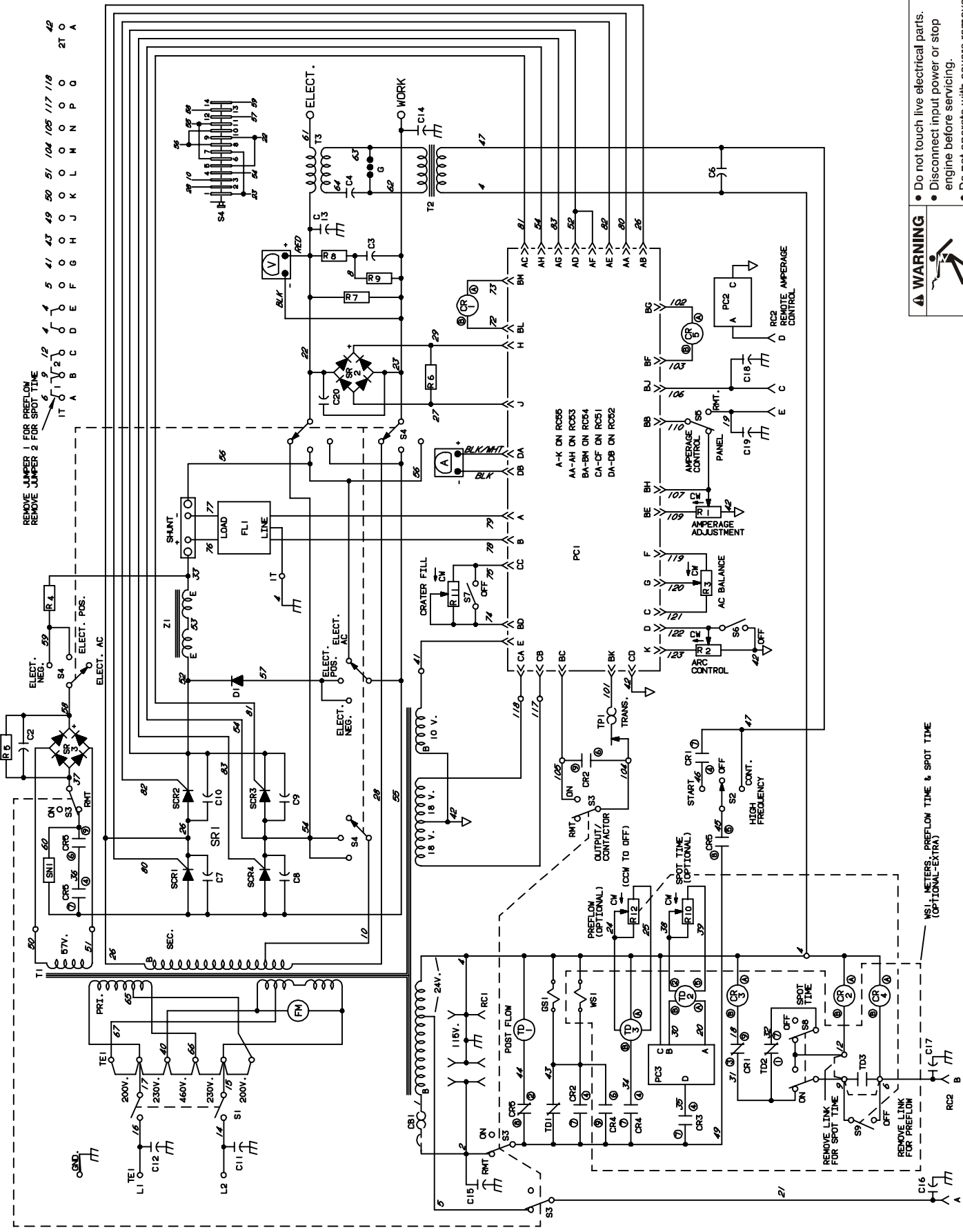

REMOVE JUMPER 1 FOR PREFLOW
REMOVE JUMPER 2 FOR SPOT TIME

WARNING

Do not touch live electrical parts.
Disconnect input power or stop engine before servicing.
Do not operate with covers removed.
Have only qualified persons install, use, or service this unit.

ELECTRIC SHOCK HAZARD

Figure 9-3. Circuit Diagram For Syncrowave 250 Effective With Serial No. JJ365634 Thru JJ503983

TM-353 Page 44

SC-121 280

Syncrowave 250

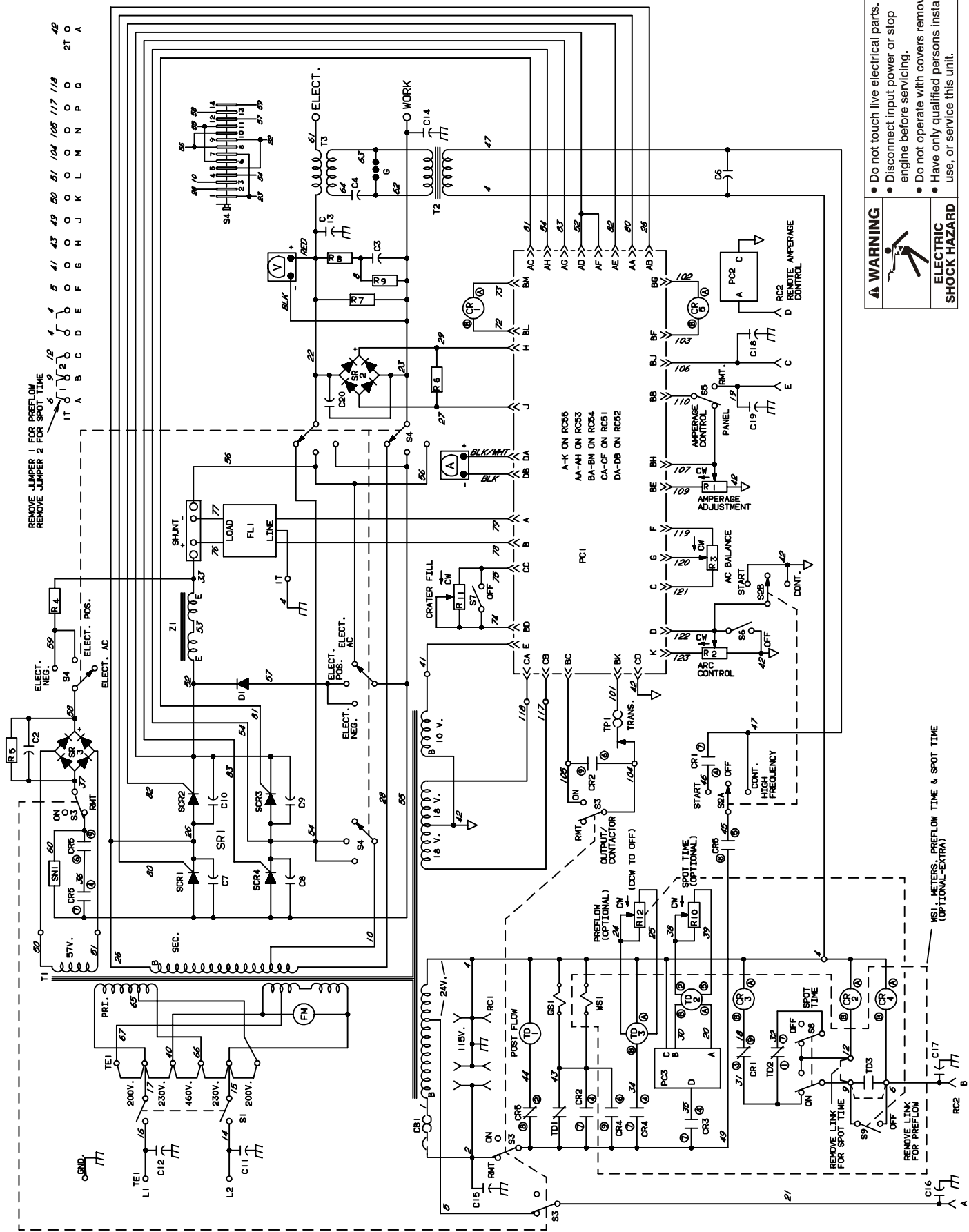

WARNING

Do not touch live electrical parts.
 Disconnect input power or stop engine before servicing.
 Do not operate with covers removed.
 Have only qualified persons install, use, or service this unit.

ELECTRIC SHOCK HAZARD

Figure 9-4. Circuit Diagram For Syncrowave 250 Effective With Serial No. JJ503984 Thru JK572897

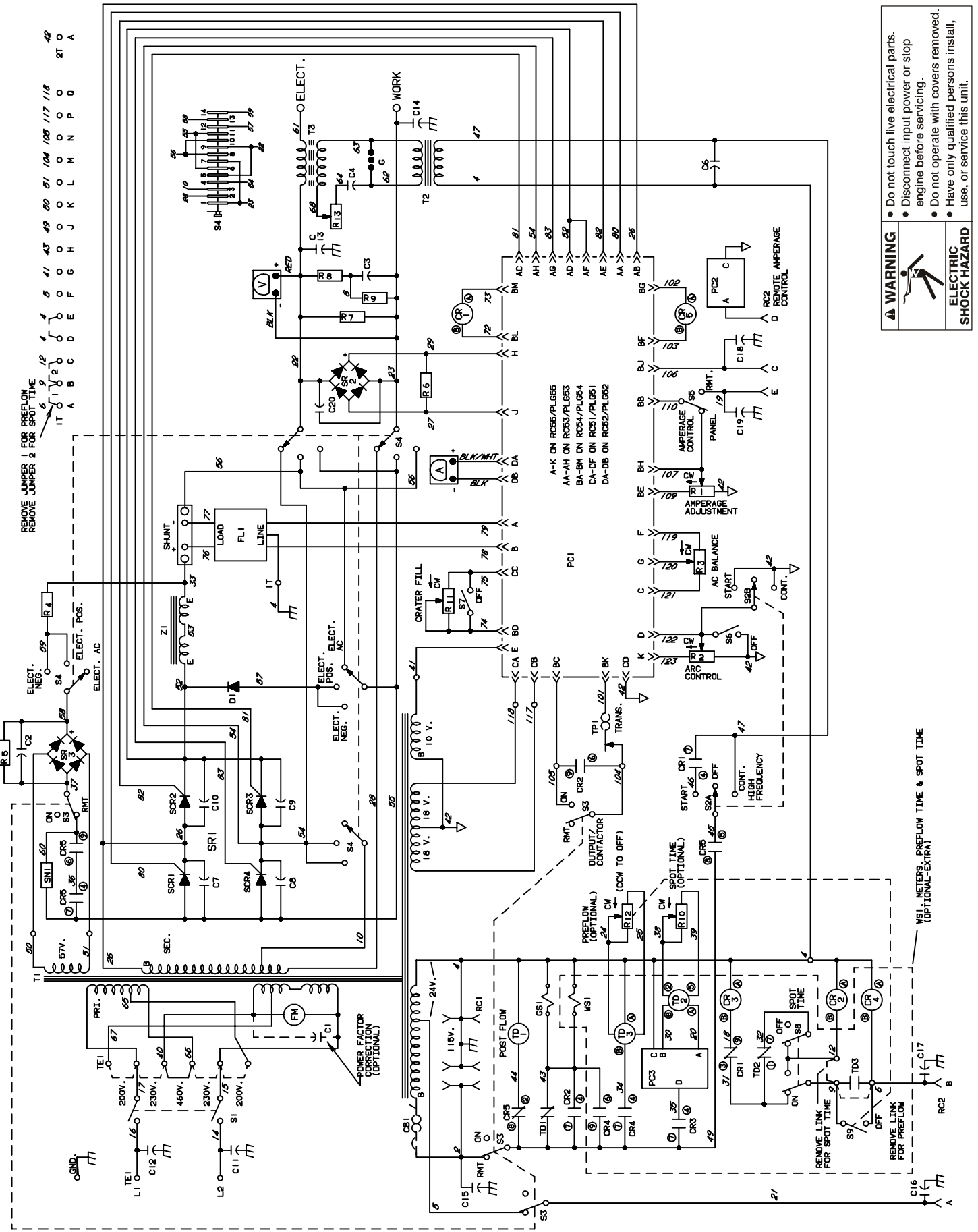

Figure 9-5. Circuit Diagram For Syncrowave 250 Effective With Serial No. JK572898 Thru JK690986
 TM-353 Page 46
 SC-124 785-B
 Syncrowave 250

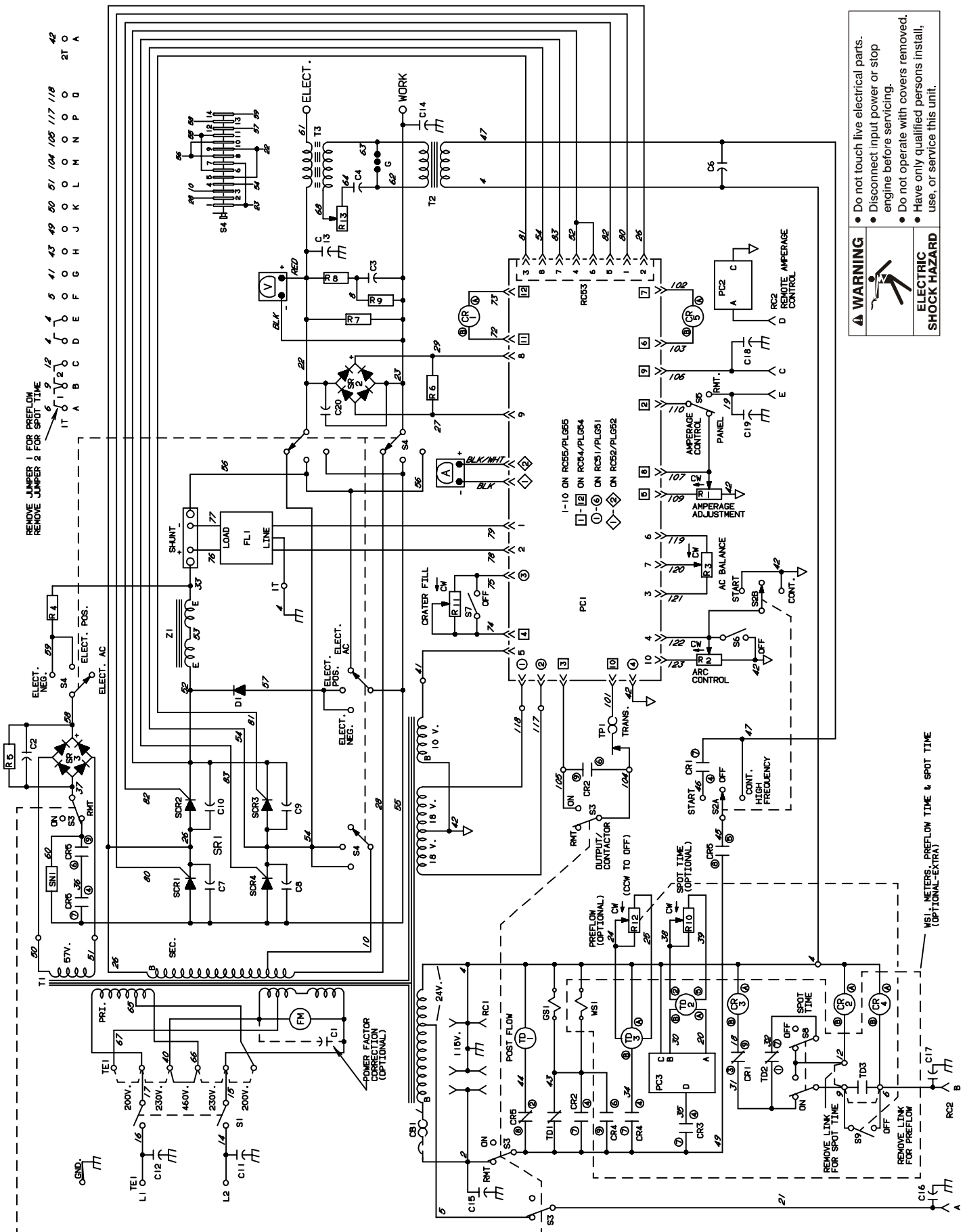

Figure 9-6. Circuit Diagram For Syncrowave 250 Effective With Serial No. JK690987 Thru KA806712

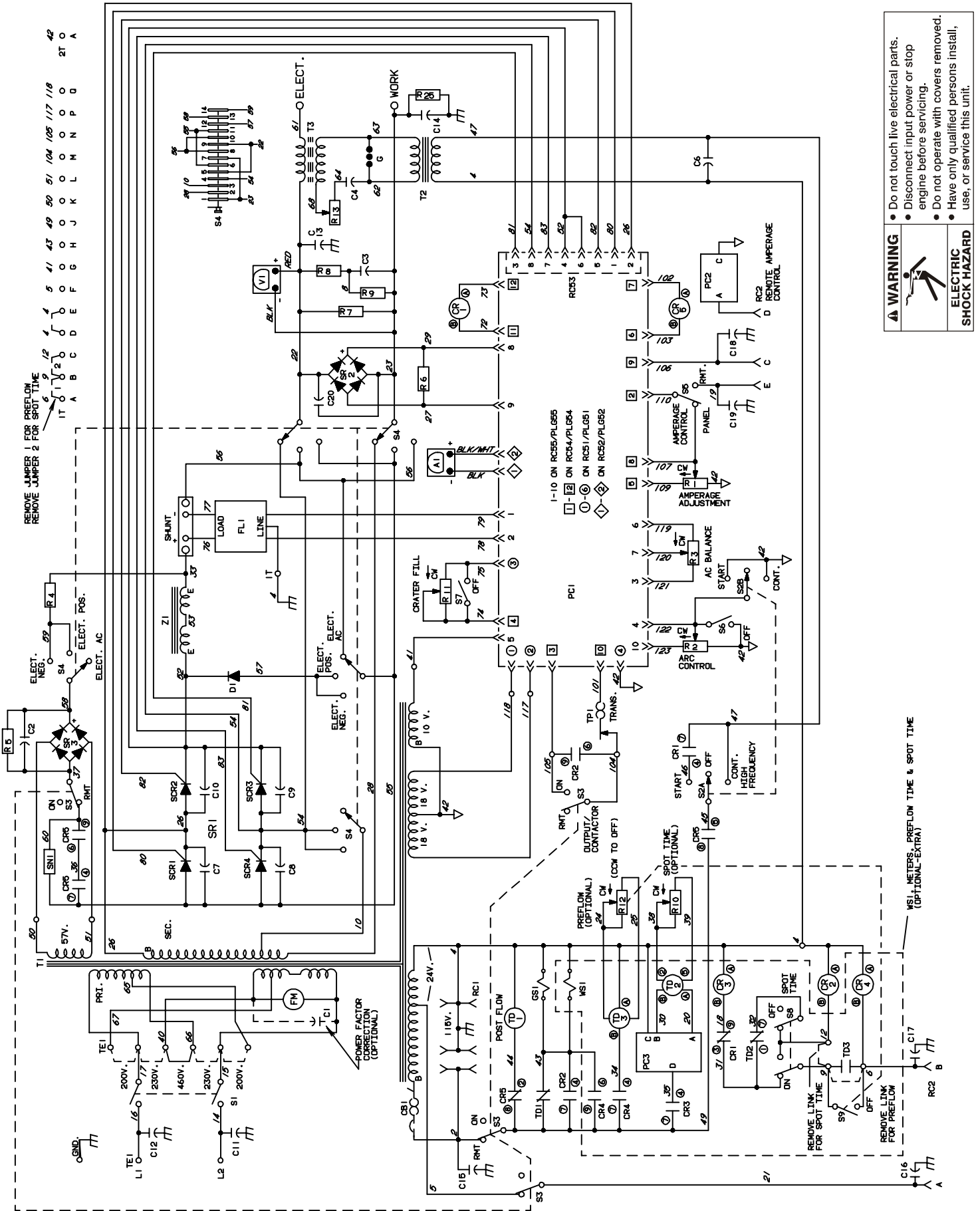

Figure 9-7. Circuit Diagram For Syncrowave 250 Effective With Serial No. KA806713 Thru KA877024

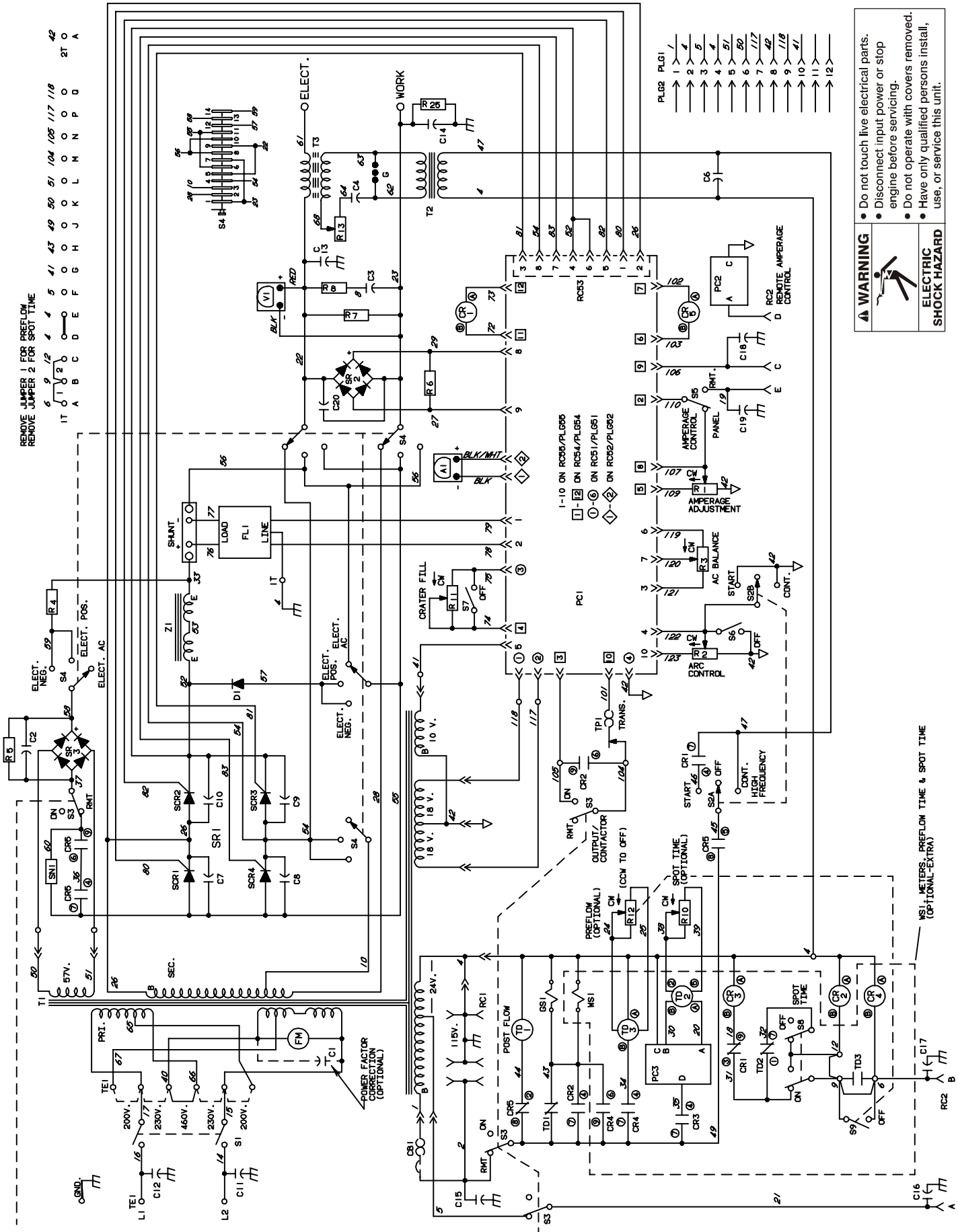
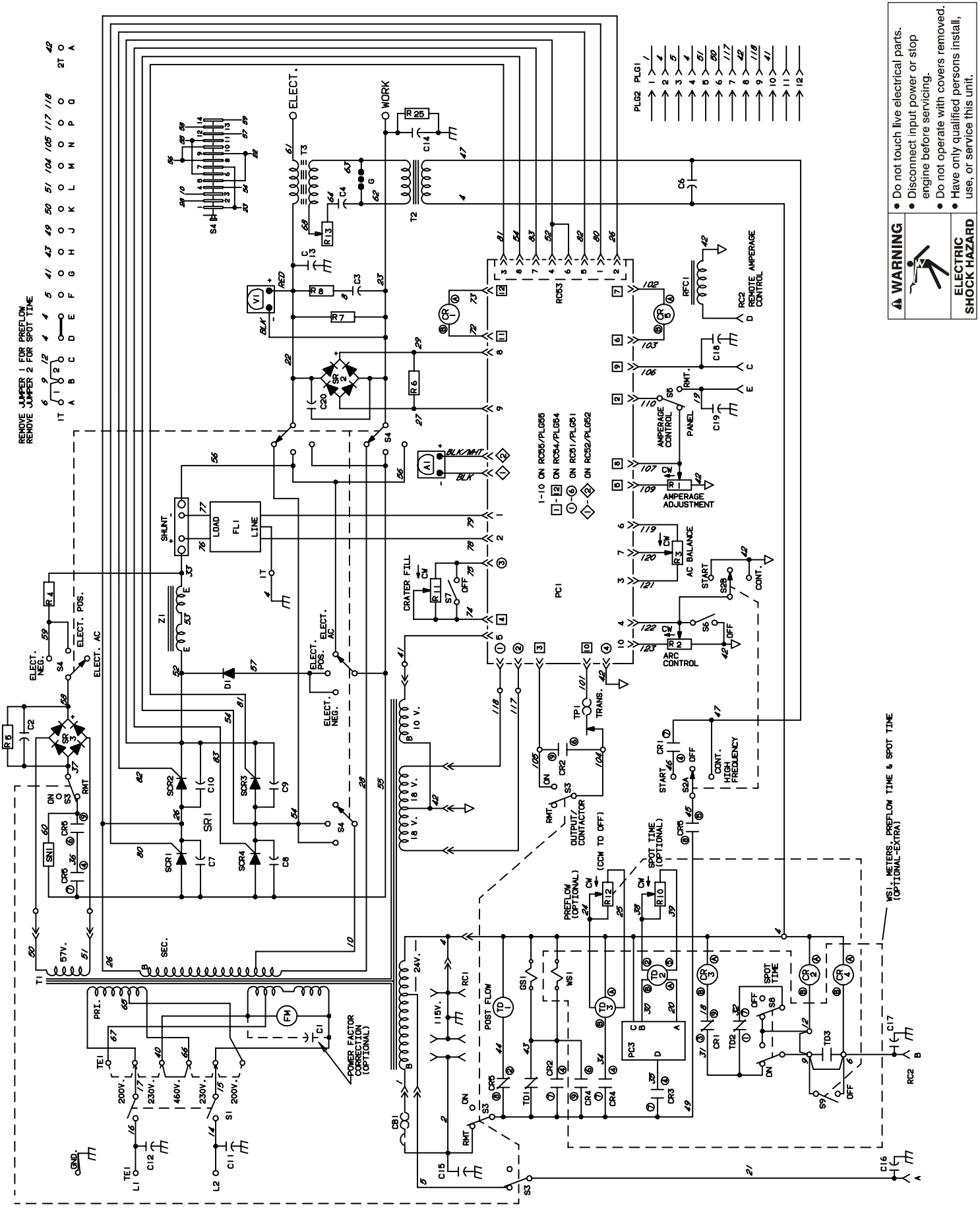

Figure 9-8. Circuit Diagram For Syncrowave 250 Effective With Serial No. KA877025 Thru KB010829



REMOVE JUMPER 1 FOR PREFLOW
REMOVE JUMPER 2 FOR SPOT TIME

IT A B C D E F G H J K L M N P O
1 2 3 4 5 6 7 8 9 10 11 12 13 14 15 16 17 18 19 20 21 22

REMOVE JUMPER 1 FOR PREFLOW
REMOVE JUMPER 2 FOR SPOT TIME

IT A B C D E F G H J K L M N P O
1 2 3 4 5 6 7 8 9 10 11 12 13 14 15 16 17 18 19 20 21 22

WARNING ⚠️

- Do not touch live electrical parts.
- Disconnect input power or stop engine before servicing.
- Do not operate with covers removed.
- Have only qualified persons install, use, or service this unit.

ELECTRIC SHOCK HAZARD

1-10 ON R055/PL055
ON R054/PL054
ON R051/PL051
ON R052/PL052

MS1 METERS, PREFLOW TIME & SPOT TIME (OPTIONAL-EXTRA)

Figure 9-9. Circuit Diagram For Syncrowave 250 Effective With Serial No. KB010830 Thru KB110694

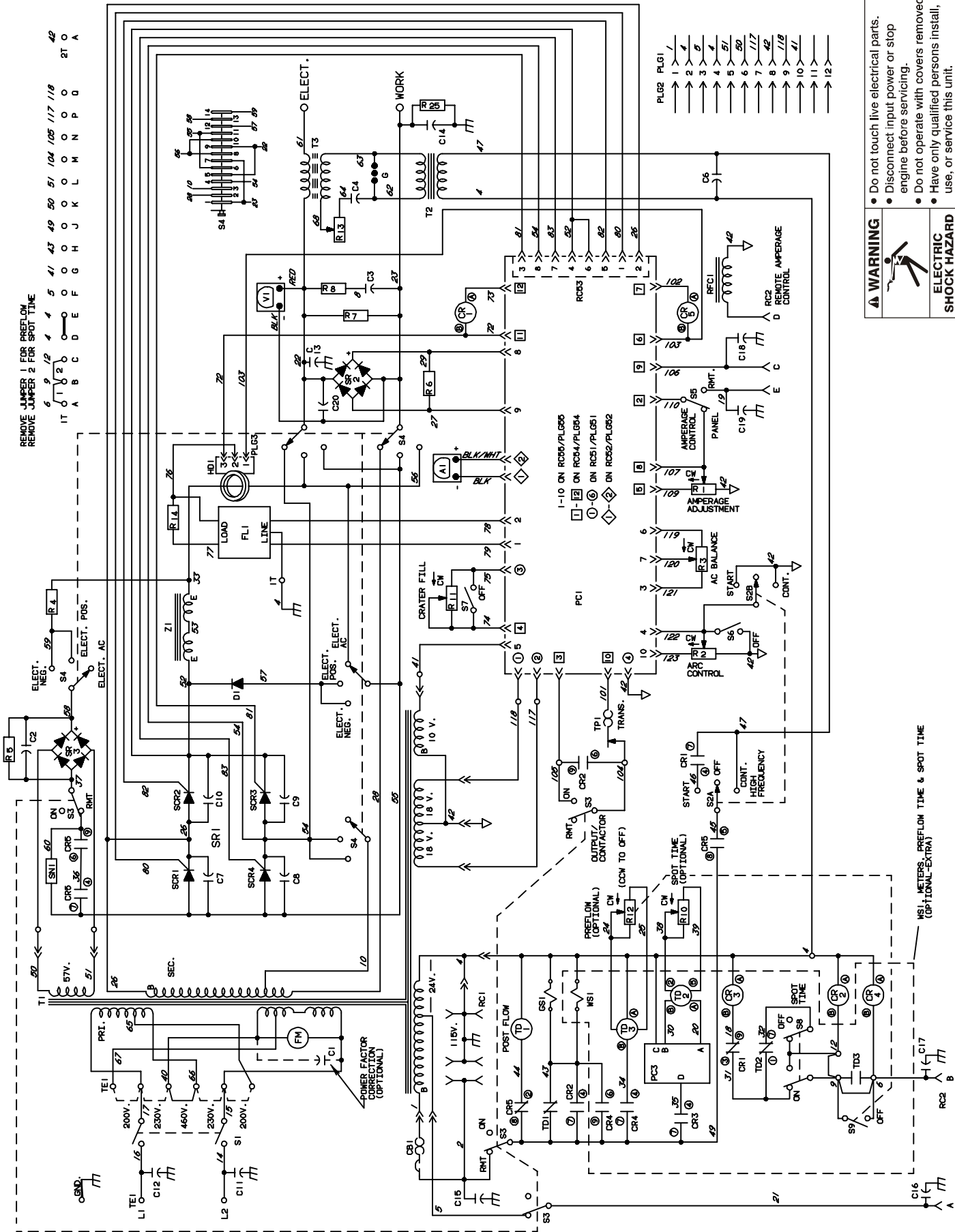
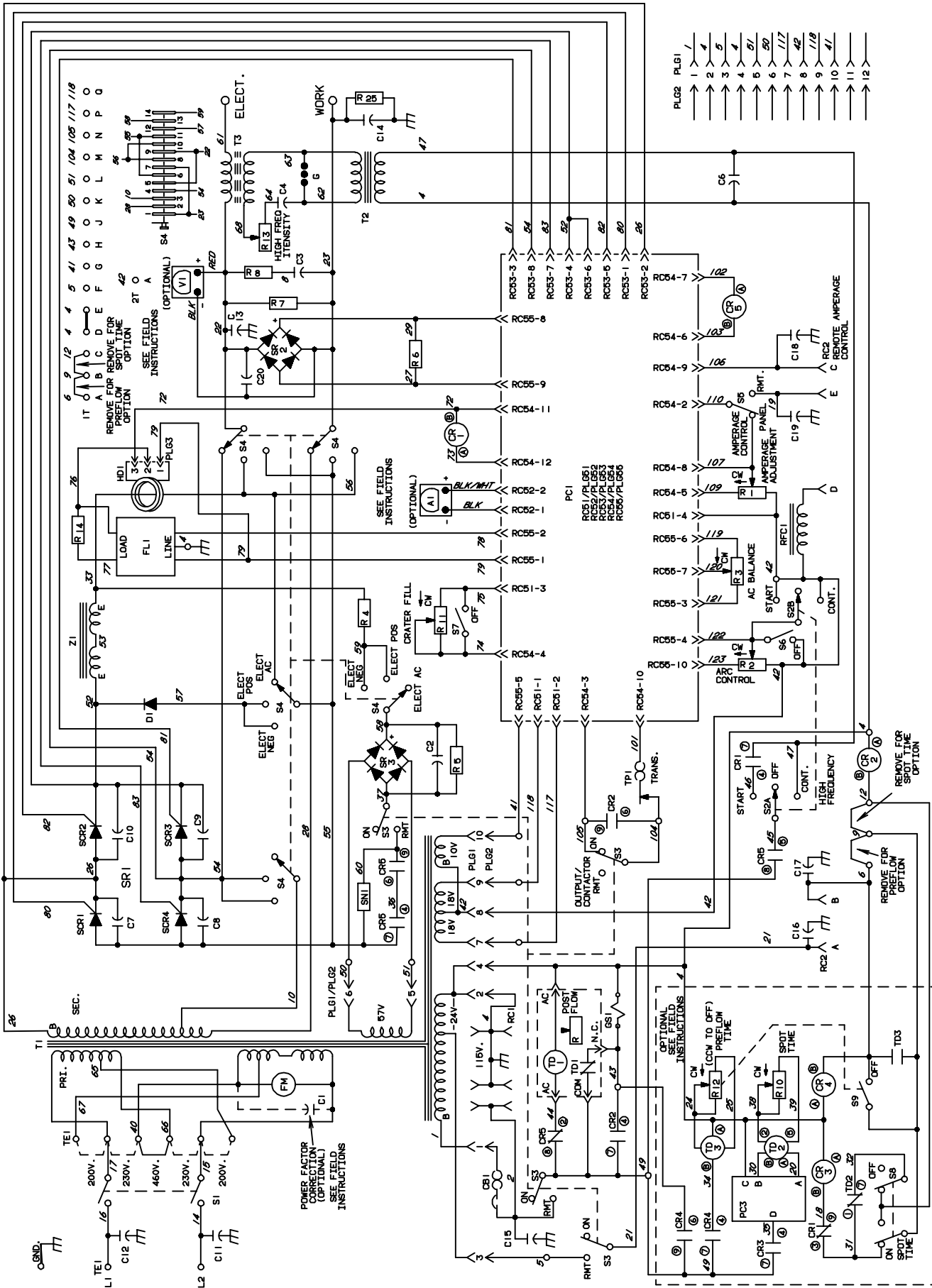

Figure 9-10. Circuit Diagram For Syncrowave 250 Effective With Serial No. KB110695 Thru KC252675



WARNING

Do not touch live electrical parts.
 Disconnect input power or stop engine before servicing.
 Do not operate with covers removed.
 Have only qualified persons install, use, or service this unit.

ELECTRIC SHOCK HAZARD

Figure 9-11. Circuit Diagram For Syncrowave 250 Effective With Serial No. KC252676 Thru KG029204

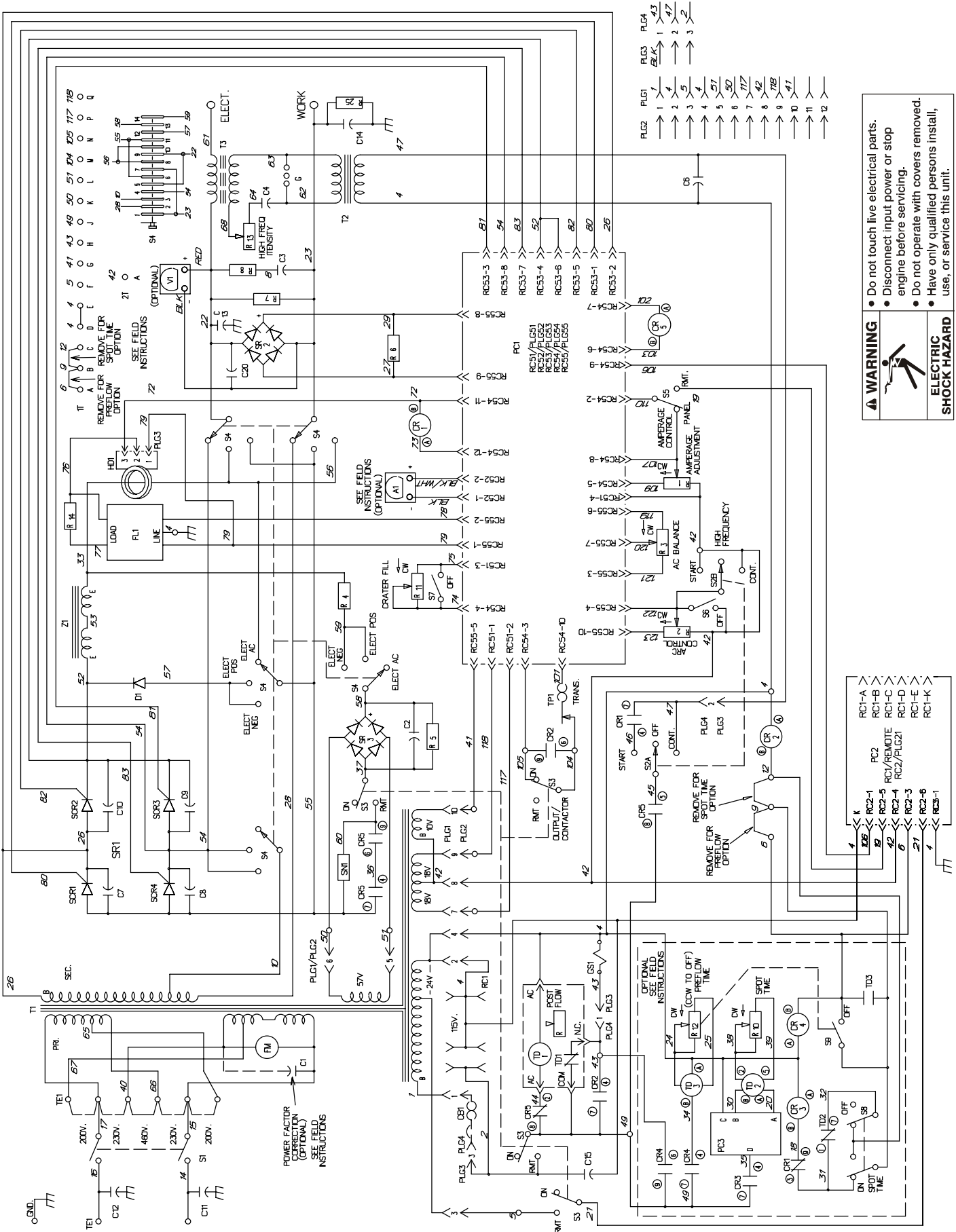

WARNING

Do not touch live electrical parts.
 Disconnect input power or stop engine before servicing.
 Do not operate with covers removed.
 Have only qualified persons install, use, or service this unit.

ELECTRIC SHOCK HAZARD

Figure 9-12. Circuit Diagram For Syncrowave 250 Effective With Serial No. KG029205 Thru KG062109

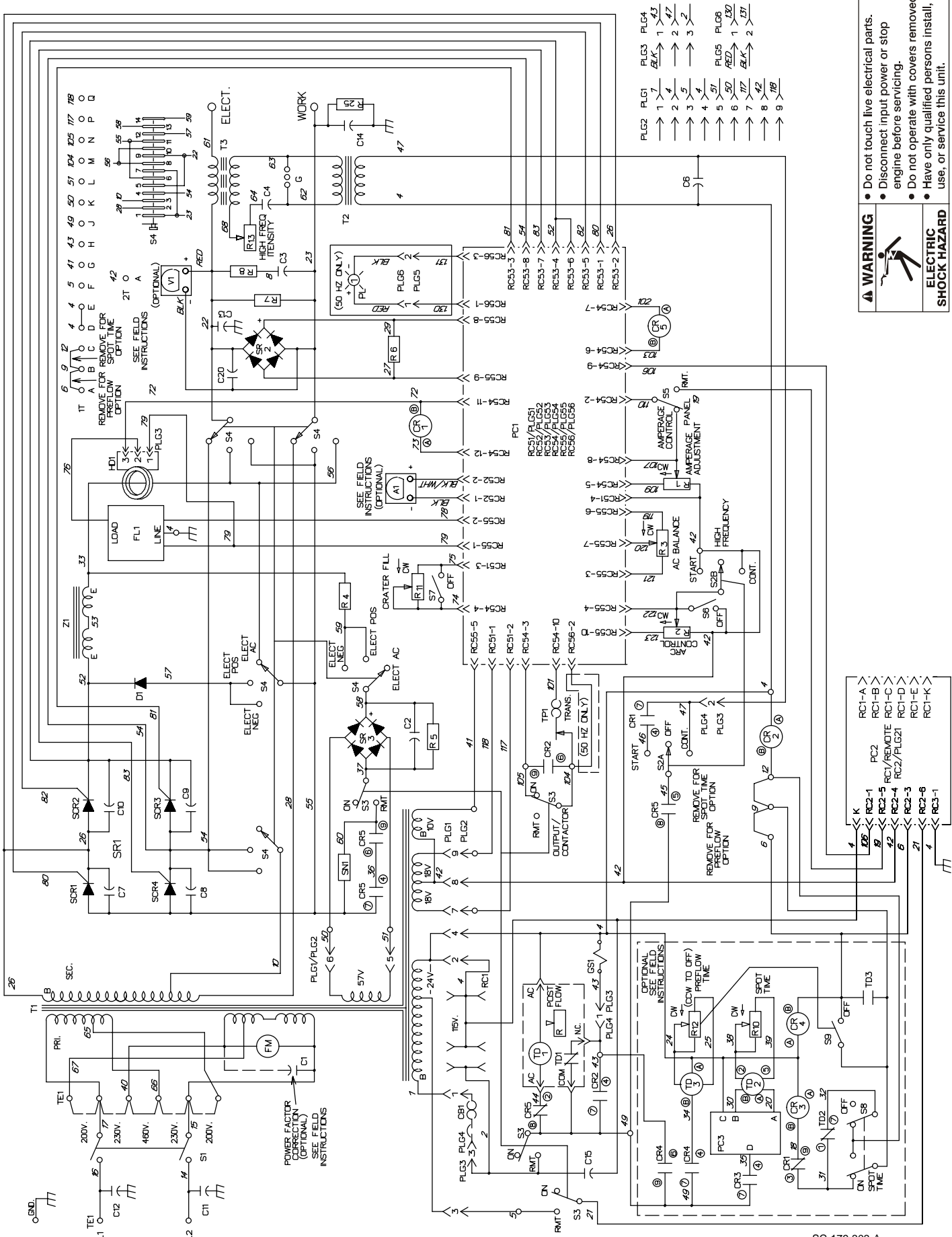
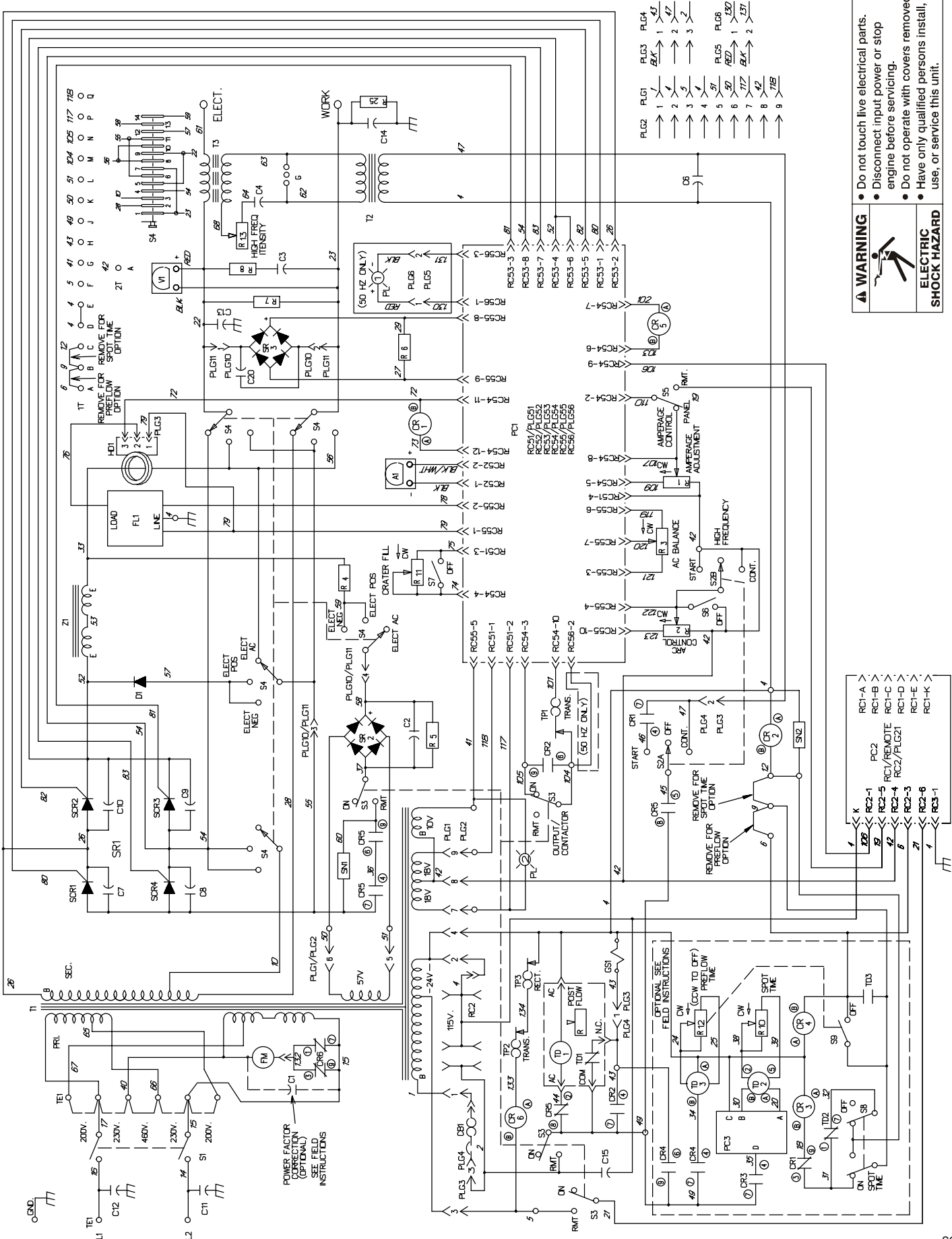

Figure 9-13. Circuit Diagram For Syncrowave 250 Effective With Serial No. KG062110 Thru KG170300
 TM-353 Page 54
 Syncrowave 250



WARNING

Do not touch live electrical parts.
 Disconnect input power or stop engine before servicing.
 Do not operate with covers removed.
 Have only qualified persons install, use, or service this unit.

ELECTRIC SHOCK HAZARD

Figure 9-14. Circuit Diagram For Syncrowave 250 Effective With Serial No. KG170301 Thru KH526230

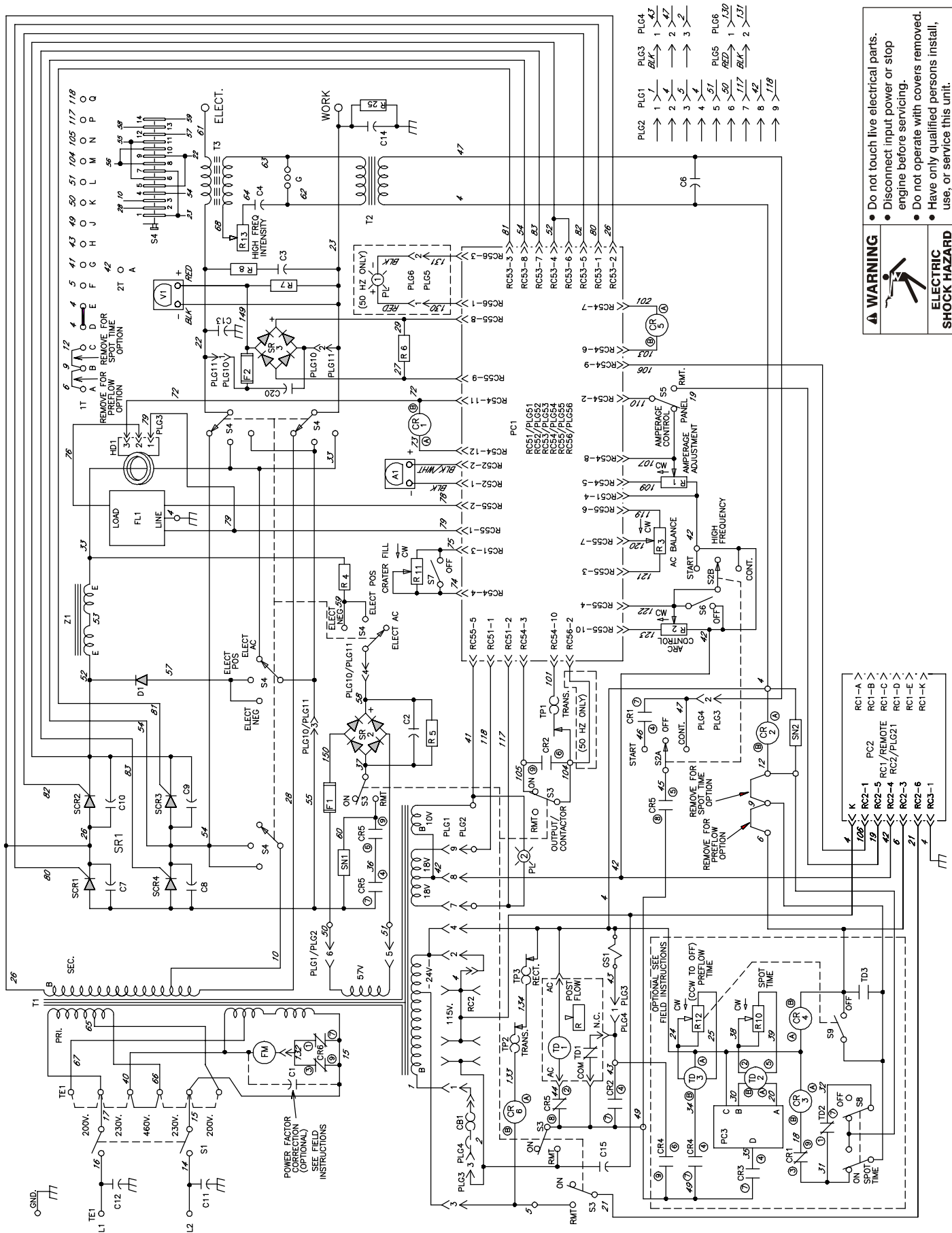



Figure 9-15. Circuit Diagram For Syncrowave 250 Effective With Serial No. KH526231 And Following

	⚠ WARNING
	<ul style="list-style-type: none"> • Do not touch live electrical parts. • Disconnect input power or stop engine before servicing. • Do not operate with covers removed. • Have only qualified persons install, use, or service this unit.
ELECTRIC SHOCK HAZARD	

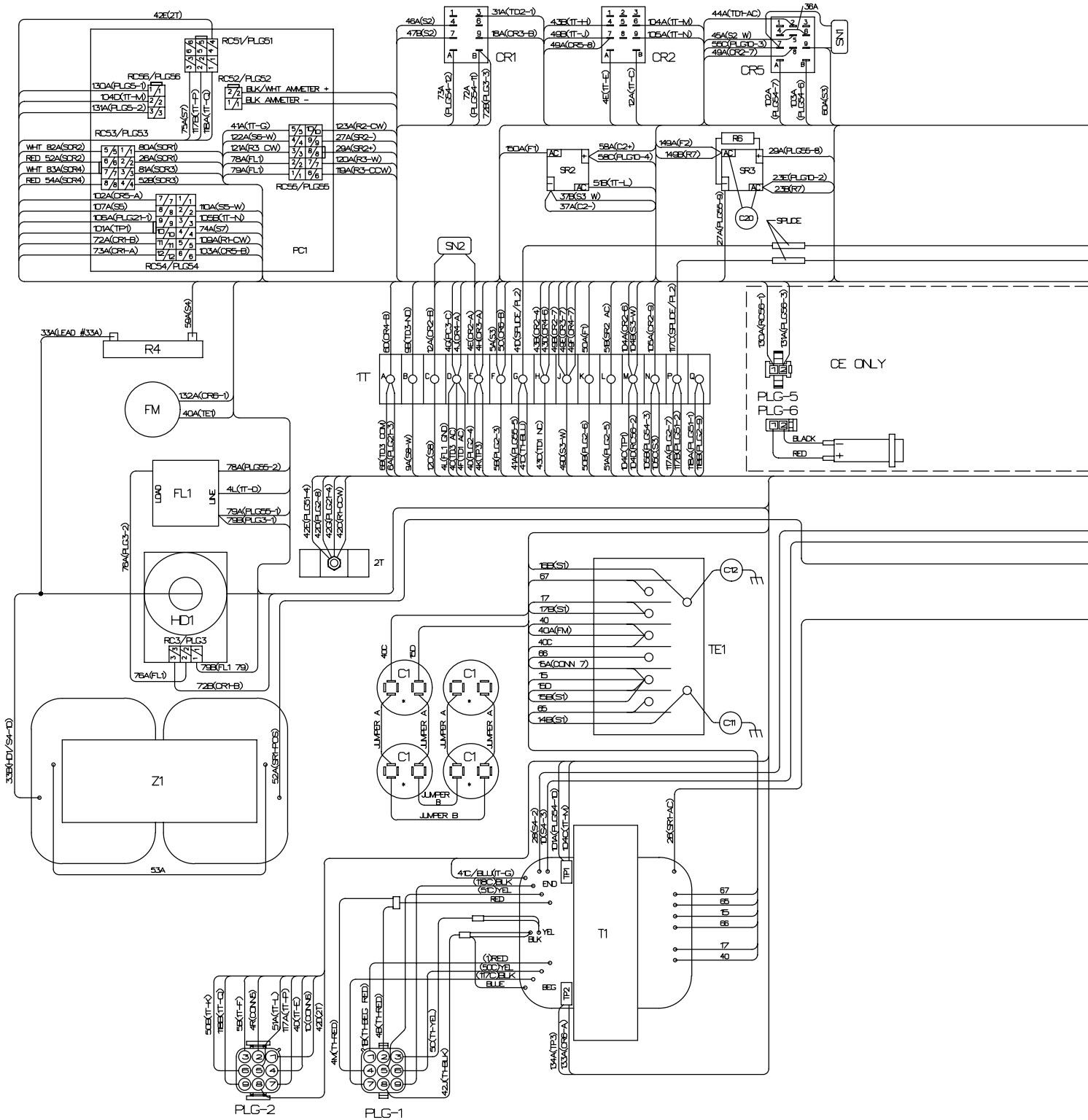
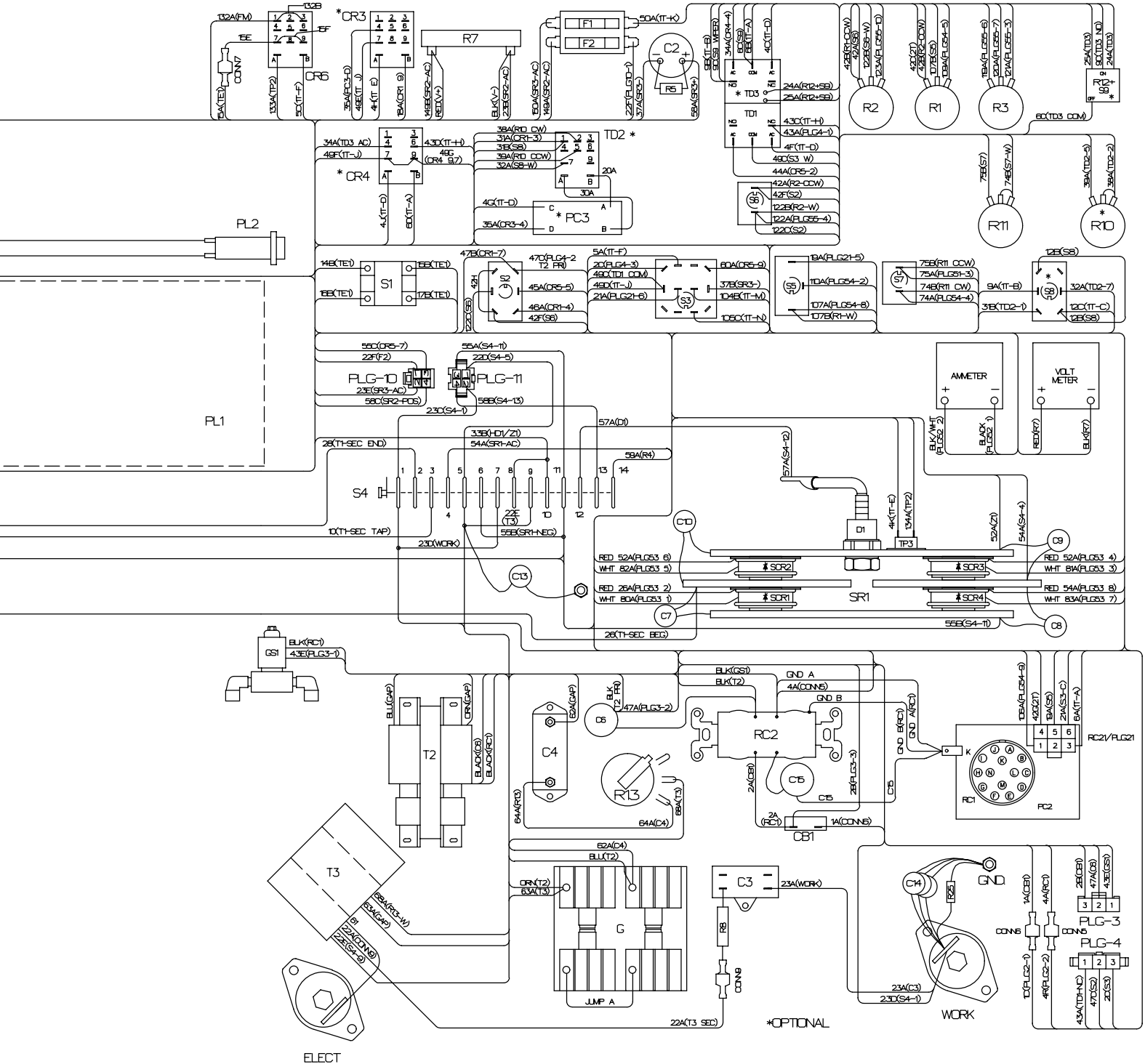

Figure 9-16. Wiring Diagram For Syncrowave 250 Effective With Serial No. KH526231 And Following



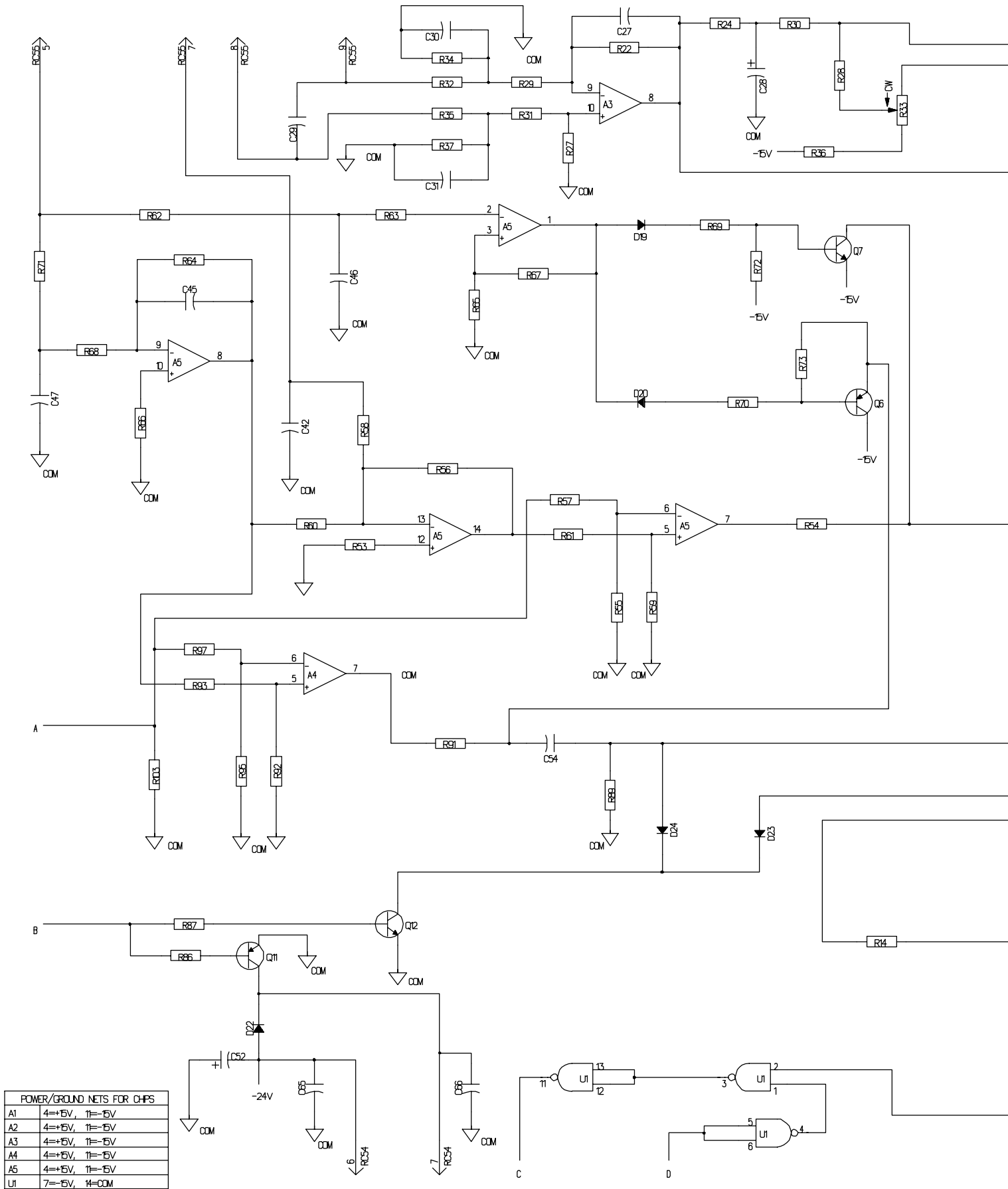
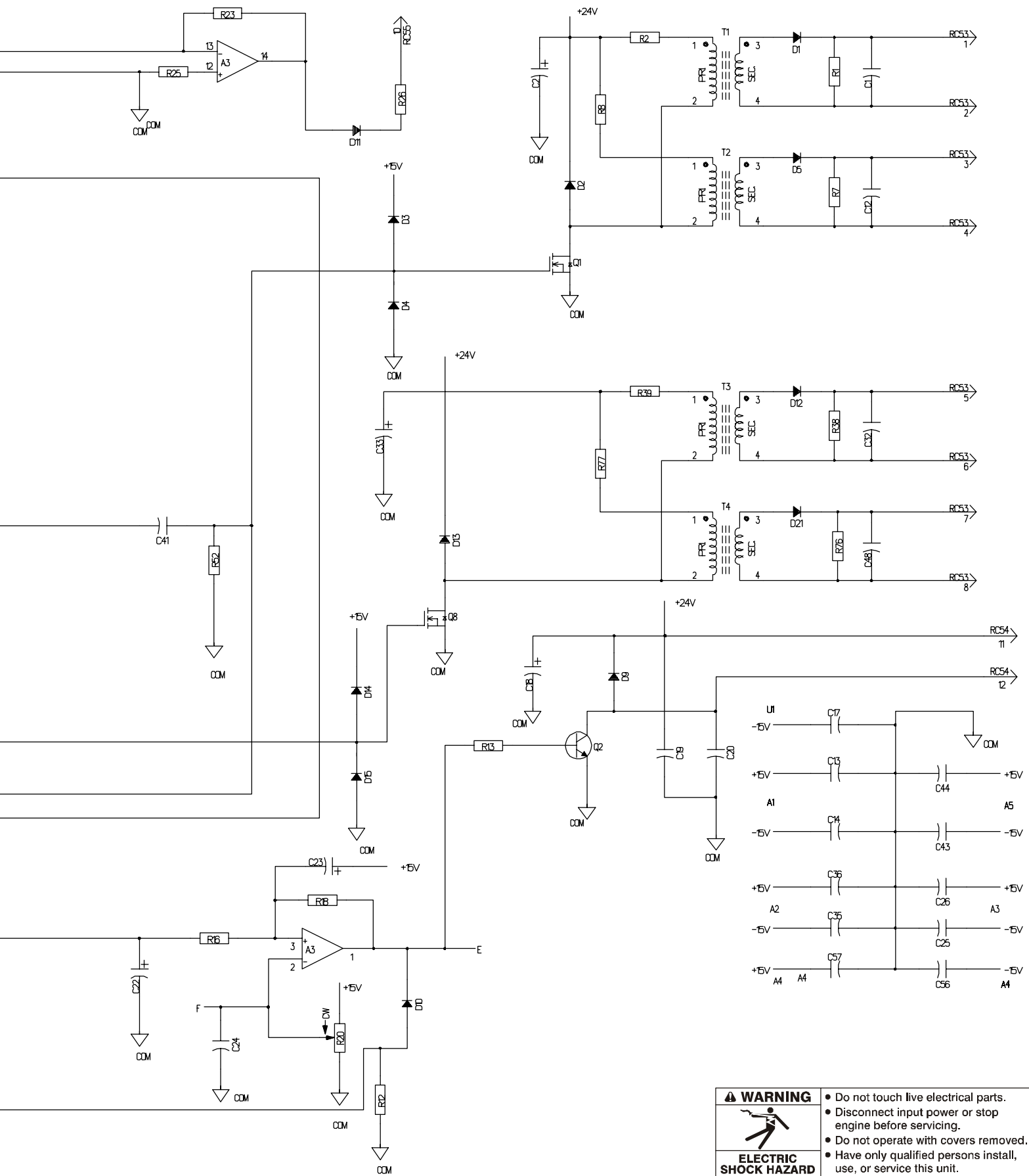



Figure 9-17. Circuit Diagram For Control Board PC1 Effective With Serial No. KH508255 And Following (Part 1 Of 2)



 ELECTRIC SHOCK HAZARD	WARNING
	<ul style="list-style-type: none"> • Do not touch live electrical parts. • Disconnect input power or stop engine before servicing. • Do not operate with covers removed. • Have only qualified persons install, use, or service this unit.

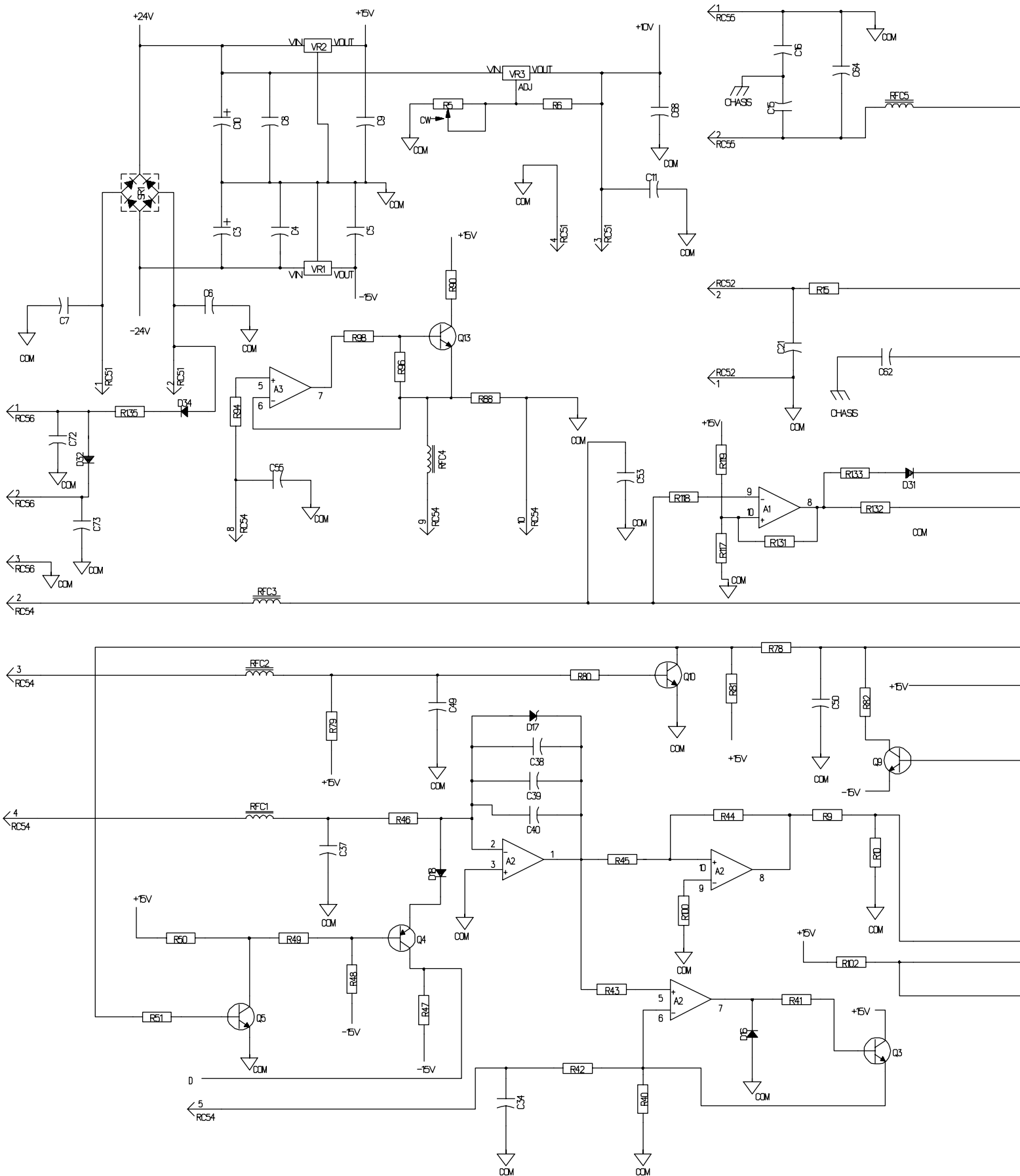
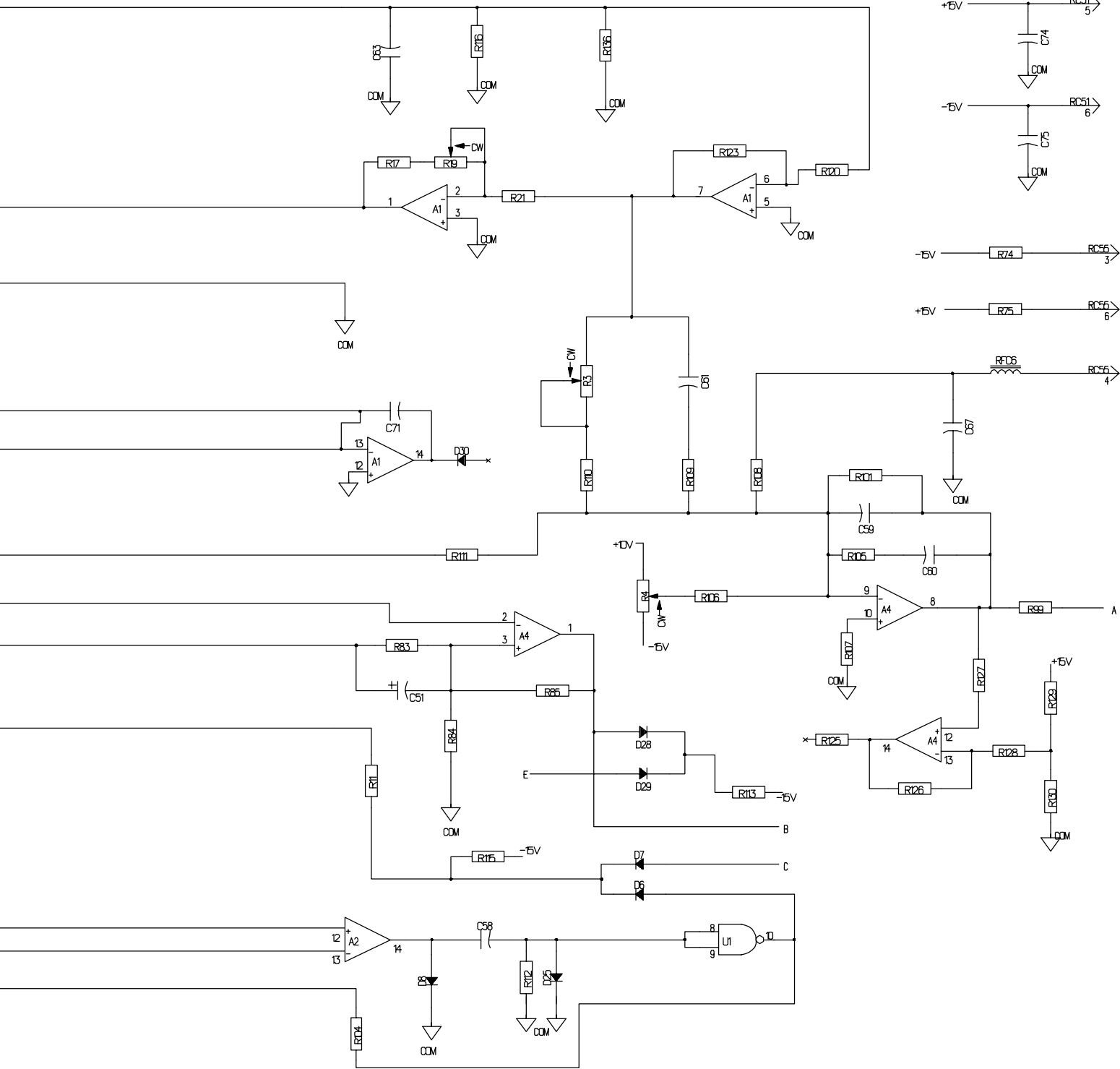

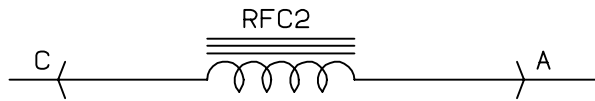

Figure 9-18. Circuit Diagram For Control Board PC1 Effective With Serial No. KH508255 And Following (Part 2 Of 2)



 ⚠ WARNING ELECTRIC SHOCK HAZARD	<ul style="list-style-type: none"> • Do not touch live electrical parts. • Disconnect input power or stop engine before servicing. • Do not operate with covers removed. • Have only qualified persons install, use, or service this unit.
---	--



SA-121 282

Figure 9-19. Circuit Diagram For RFC Board PC2 Effective With Serial No. JJ365634 Thru KB010829

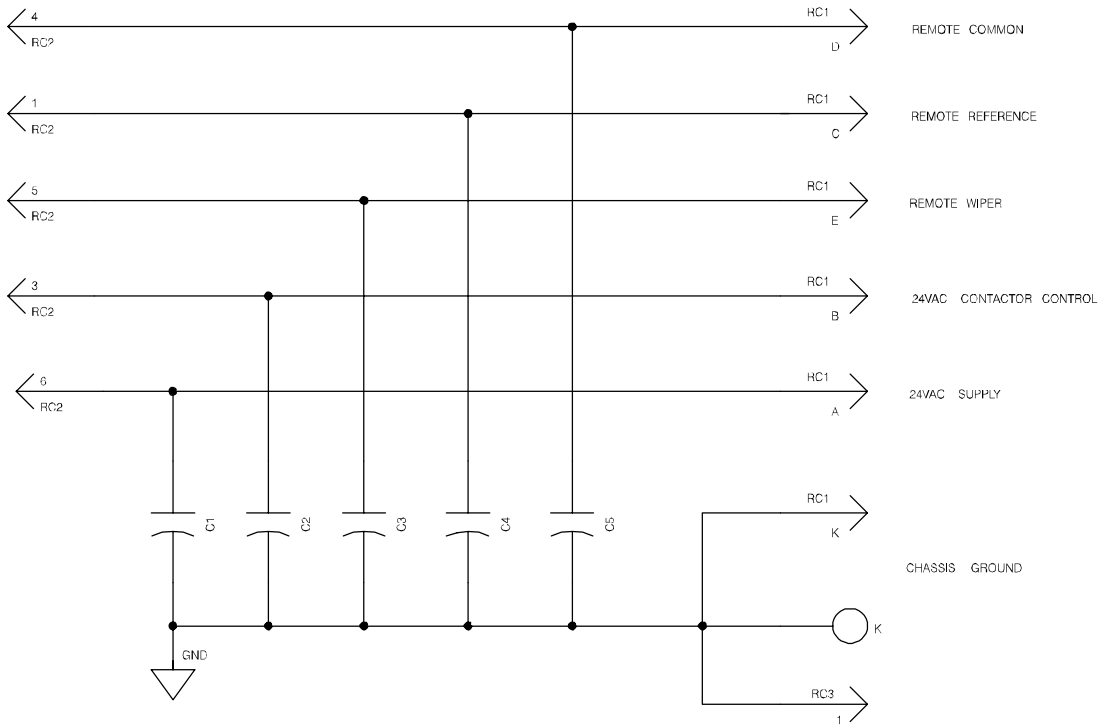

SA-158 763

Figure 9-20. Circuit Diagram For Remote 14 Filter Board PC2 Effective With Serial No. KF959379 And Following

 ELECTRIC SHOCK HAZARD	WARNING
	<ul style="list-style-type: none"> • Do not touch live electrical parts. • Disconnect input power or stop engine before servicing. • Do not operate with covers removed. • Have only qualified persons install, use, or service this unit.

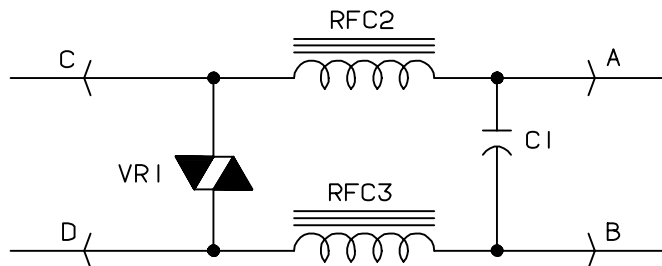

SA-120 872

Figure 9-21. Circuit Diagram For Optional Snubber Board PC3 Effective With Serial No. JJ351865 And Following

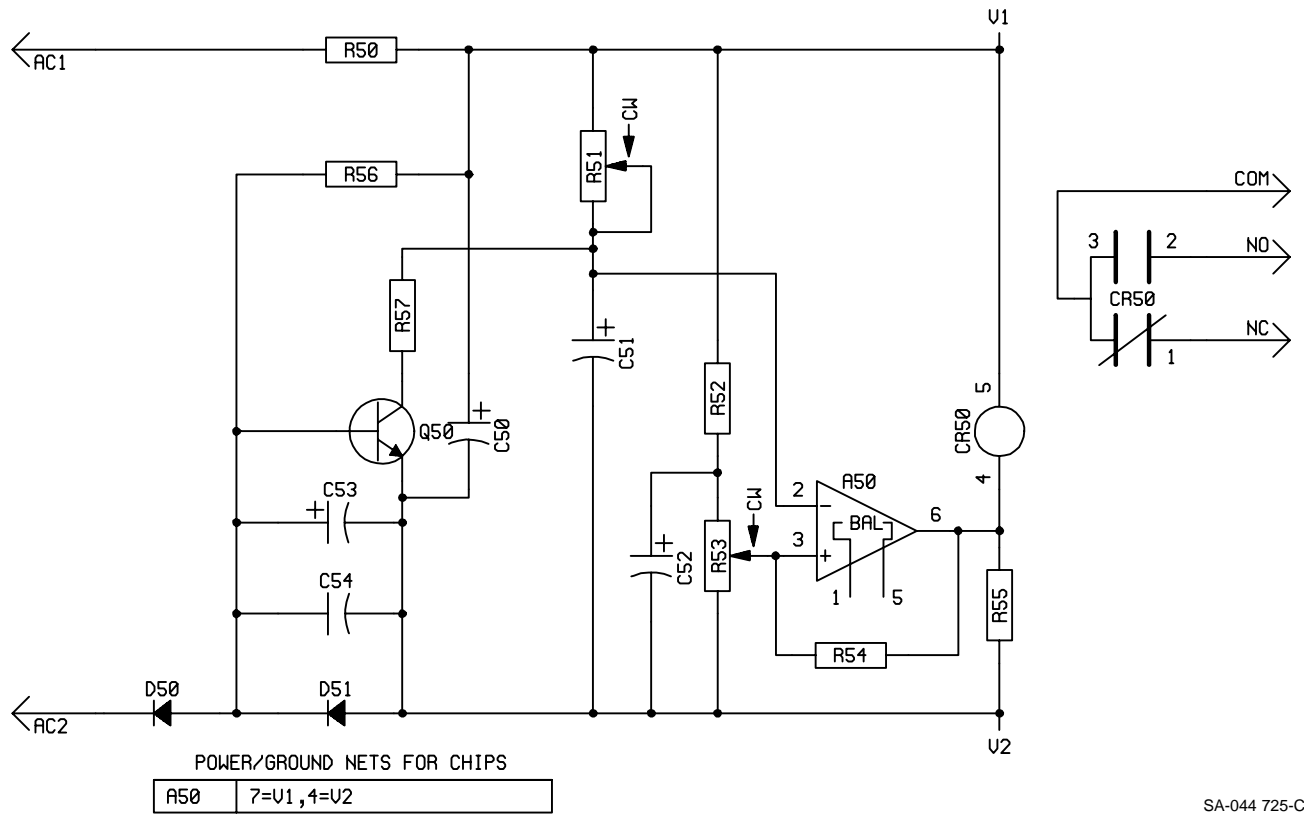

SA-044 725-C

Figure 9-23. Circuit Diagram For Postflow Timer Board TD1 Effective With Serial No. JJ339876 And Following

<p>WARNING</p> <p>ELECTRIC SHOCK HAZARD</p>	<ul style="list-style-type: none"> Do not touch live electrical parts. Disconnect input power or stop engine before servicing. Do not operate with covers removed. Have only qualified persons install, use, or service this unit.
---	--

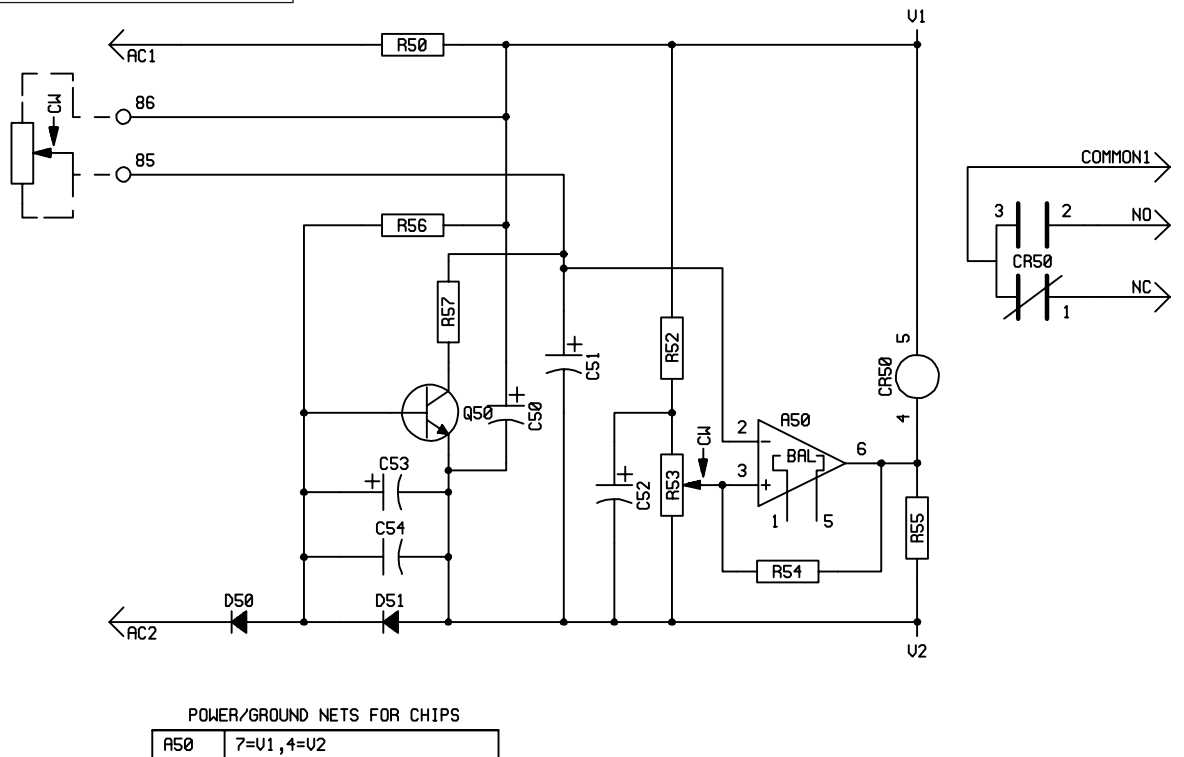

SA-045 288-D

Figure 9-22. Circuit Diagram For Optional Preflow Timer Board TD3 Effective With Serial No. JJ339876 And Following



TM-353E January 2001

Eff. w/Serial Number JJ339876

Processes



TIG (GTAW) Welding



Stick (SMAW) Welding

Description



Arc Welding Power Source



Syncrowave[®] 250

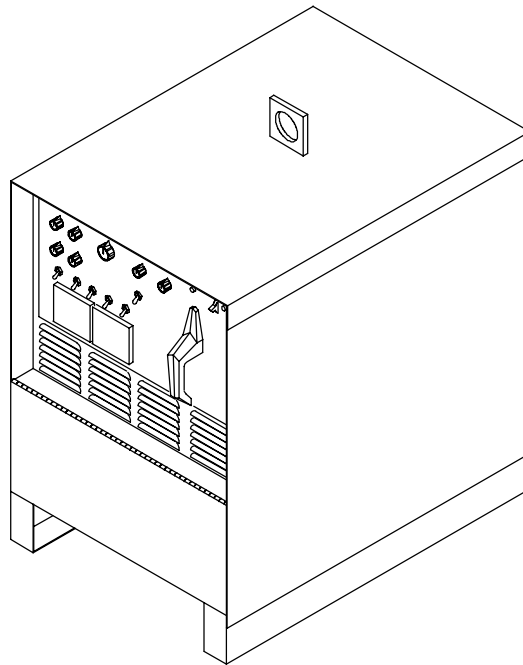

60 Hz, 50 Hz

PARTS LIST



Visit our website at
www.MillerWelds.com

SECTION 10 – PARTS LIST

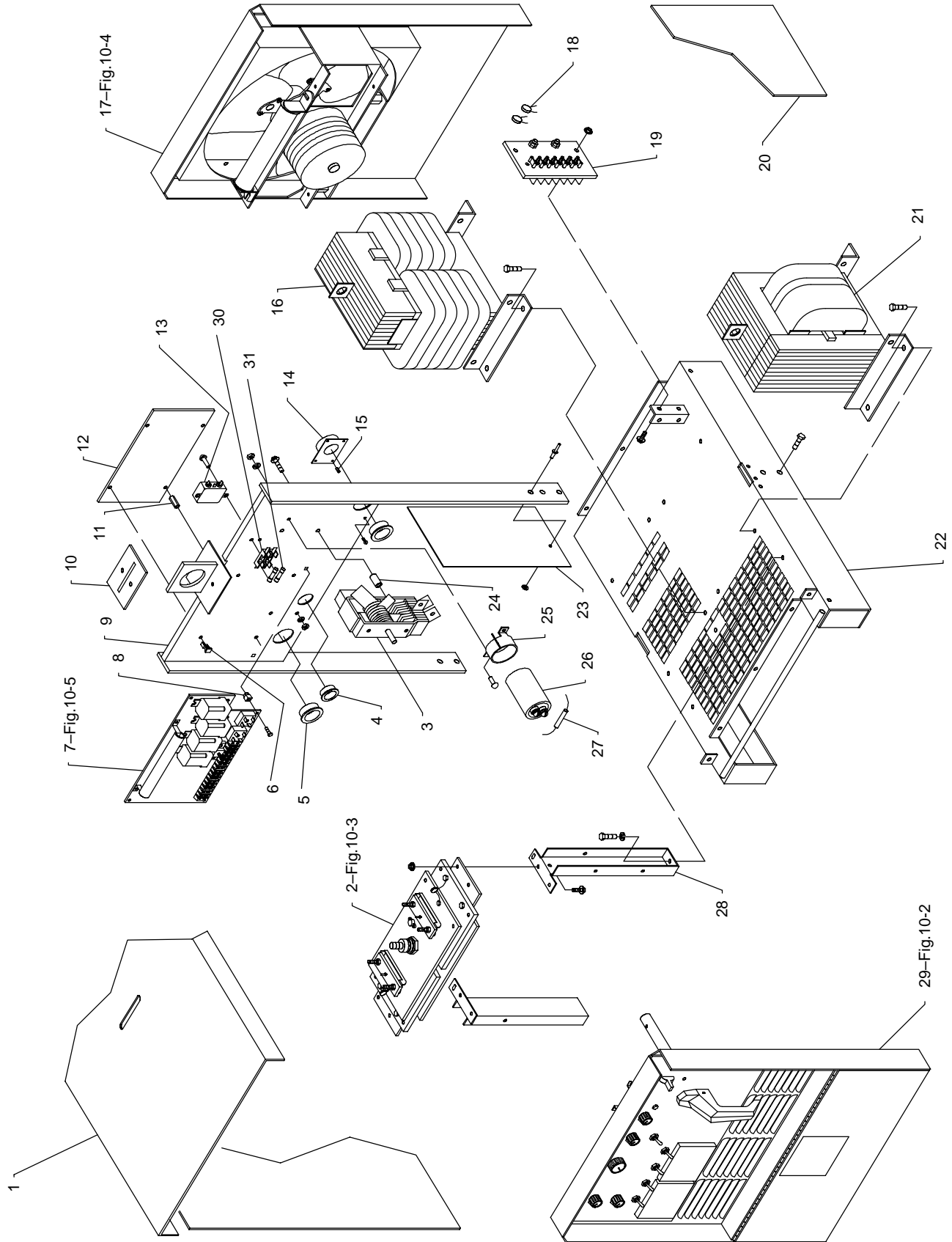

 Hardware is common and not available unless listed.

Figure 10-1. Main Assembly

ST-120 135-R

Item No.	Dia. Mkgs.	Part No.	Description	Quantity
----------	------------	----------	-------------	----------

Figure 10-1. Main Assembly

. 1		114 741	.. COVER, top (Prior to KG170301)	1
. 1		182 605	.. COVER, top (Eff w/KG170301)	1
. 2	SR1	181 106	.. RECTIFIER, si diode (Fig 10-3)	1
. 3	S4	112 630	.. SWITCH, plrty/changeover (Prior to KA759476)	1
. 3	S4	133 061	.. SWITCH, plrty/changeover (Eff w/KA759476)	1
	PLG10	164 899	.. CONNECTOR & SOCKETS	1
	PLG11	168 809	.. CONNECTOR & SOCKETS	1
	C13	155 082	.. CAPACITOR, cer disc. .003 200VAC (Prior to JK690987)	1
	C13	132 433	.. CAPACITOR, cer disc. .05uf 500VDC (Eff w/JK690987)	1
. 4		057 357	.. BUSHING, snap-in nyl .937 ID x 1.125mtg hole	1
. 5		010 494	.. BUSHING, snap-in nyl 1.375 ID x1.750mtg hole	2
. 6		110 375	.. STAND-OFF SUPPORT, PC card No. 6 screw (Prior to KG170301)	3
. 6		134 201	.. STAND-OFF SUPPORT, PC card No. 6 screw (Eff w/KG170301)	3
. 7		Fig 10-4	.. PANEL, mtg components	1
. 8		083 147	.. GROMMET, screw No. 8/10 panel hole .312sq .500 high	4
. 9		114 754	.. FRAME, lifting (Prior to KG170301)	1
. 9		181 101	.. FRAME, lifting (Eff w/KG170301)	1
10		026 627	.. GASKET, lift eye	1
11		070 026	.. STAND-OFF, 6-32 x .437 lg	1
12	PC1	117 981	.. CIRCUIT CARD, control (Prior to JJ389988) (Fig 10-5)	1
12	PC1	138 058	.. CIRCUIT CARD, control (Eff w/JJ389988 thru KB110694) (Fig 10-5)	1
12	PC1	180 014	.. CIRCUIT CARD, control (Eff w/ KB110695 thru KG060803)	1
12	PC1	187 642	.. CIRCUIT CARD, control (Eff w/KG060804)	1
	PLG51	115 093	.. CONNECTOR PLUG & SOCKETS	1
	PLG54	130 203	.. CONNECTOR PLUG & SOCKETS	1
	PLG55	115 091	.. CONNECTOR PLUG & SOCKETS	1
13	R14	138 105	.. RESISTOR, (Eff w/KB110695 thru KG062110)	1
13	FL1	084 171	.. FILTER, line power 115/250V	1
14	HD1	156 313	.. TRANSDUCER, current 300A (Eff w/KB110695)	1
	PLG3	130 204	.. CONNECTOR & SOCKETS, (Eff w/KB110695)	1
15		073 756	.. STAND-OFF, 6-32 x .625 lg (Eff w/KB110695)	2
16	Z1	114 826	.. REACTOR	1
17		Fig 10-4	.. PANEL, rear w/components	1
		109 035	.. LABEL, warning electric shock can kill etc	1
18	C11,12	111 634	.. CAPACITOR	1
		172 078	.. BRACKET, mtg primary board (Eff w/KE727074)	1
19	TE1	034 587	.. TERMINAL ASSEMBLY, pri (consisting of)	1
		601 835	.. NUT, brs hex 10-32	12
		601 836	.. NUT, brs hex .250-20 jam hvy	4
		010 915	.. WASHER, flat brs .250 ID x .625 OD x .031thk	4
		083 426	.. TERMINAL BOARD, primary	1
		038 888	.. STUD, primary board brs .250-20 x 1.500	2
		010 913	.. WASHER, flat brs .218 ID x 460 OD x .031thk	6
		038 887	.. STUD, primary board brs 10-32 x 1.375	6
		038 618	.. LINK, jumper term bd pri	2
20		+114 751	.. PANEL, side (Prior to KG170301)	2
20		+181 097	.. PANEL, side (Eff w/KG170301 thru KG181270)	2
20		+182 606	.. PANEL, side (Eff w/KG181271 and on)	2
21	T1	115 097	.. TRANSFORMER, pwr main 200/230/460 (Prior to KA877025)	1
21	T1	138 171	.. TRANSFORMER, pwr main 200/230/460 (Eff w/KA877025 thru KG082621)	1
21	T1	180 674	.. TRANSFORMER, pwr main 200/230/460 (Eff w/KG082622)	1
21	T1	138 175	.. TRANSFORMER, pwr main (220/380/415 (Prior to KG082622)	1
21	T1	180 673	.. TRANSFORMER, pwr main 220/380/415 (Eff w/KG082622)	1
21	T1	121 161	.. TRANSFORMER, pwr main 230/460/575 (Prior to KA877025)	1
21	T1	138 172	.. TRANSFORMER, pwr main 230/460/575 (Eff w/KA877025 thru KG082621)	1
21	T1	180 672	.. TRANSFORMER, pwr main 230/460/575 (Eff w/KG082622)	1
21	T1	191 887	.. TRANSFORMER, pwr main 260/380/520	1
	TP1	020 520	.. THERMOSTAT, NC (included w/transformer)	1
	TP2	168 891	.. THERMOSTAT, NC (Eff w/KG170301)	1

Item No.	Dia. Mkgs.	Part No.	Description	Quantity
Figure 10-1. Main Assembly (Continued)				
22		114 755	.. BASE, (Prior to KE727074)	1
22		170 748	.. BASE, (Eff w/KE727074 thru KF959176)	1
22		171 677	.. BASE, (Eff w/KF959177)	1
23		157 196	.. INSULATOR, upright (Eff w/KC307050)	1
24		010 199	.. TUBING, stl .500 OD x 17ga x 1	2
25		108 105	.. CLAMP, capacitor 2.500dia	1
26	.. C2	031 668	.. CAPACITOR, elctlt 4000uf 100VDC	1
27	.. R5	117 803	.. RESISTOR, WW fxd 10W 1K ohm	1
28		114 722	.. BRACKET, mtg rectifier	2
29		Fig 10-2	.. PANEL, front w/components	1
30		098 376	.. FUSE, holder (Eff w/KH526231)	1
31	.. F1,2	085 874	.. FUSE, mintr gl slo-blo 10A (Eff w/KH526231)	1
		092 368	.. TUBING, stl .250 ID x 16ga x 3 (Prior to JK682714)	1
		130 764	.. TUBING, stl .250 ID x 16ga wall x 1.500 (Eff w/JK682714)	1

+When ordering a component originally displaying a precautionary label, the label should also be ordered.
BE SURE TO PROVIDE MODEL AND SERIAL NUMBER WHEN ORDERING REPLACEMENT PARTS.

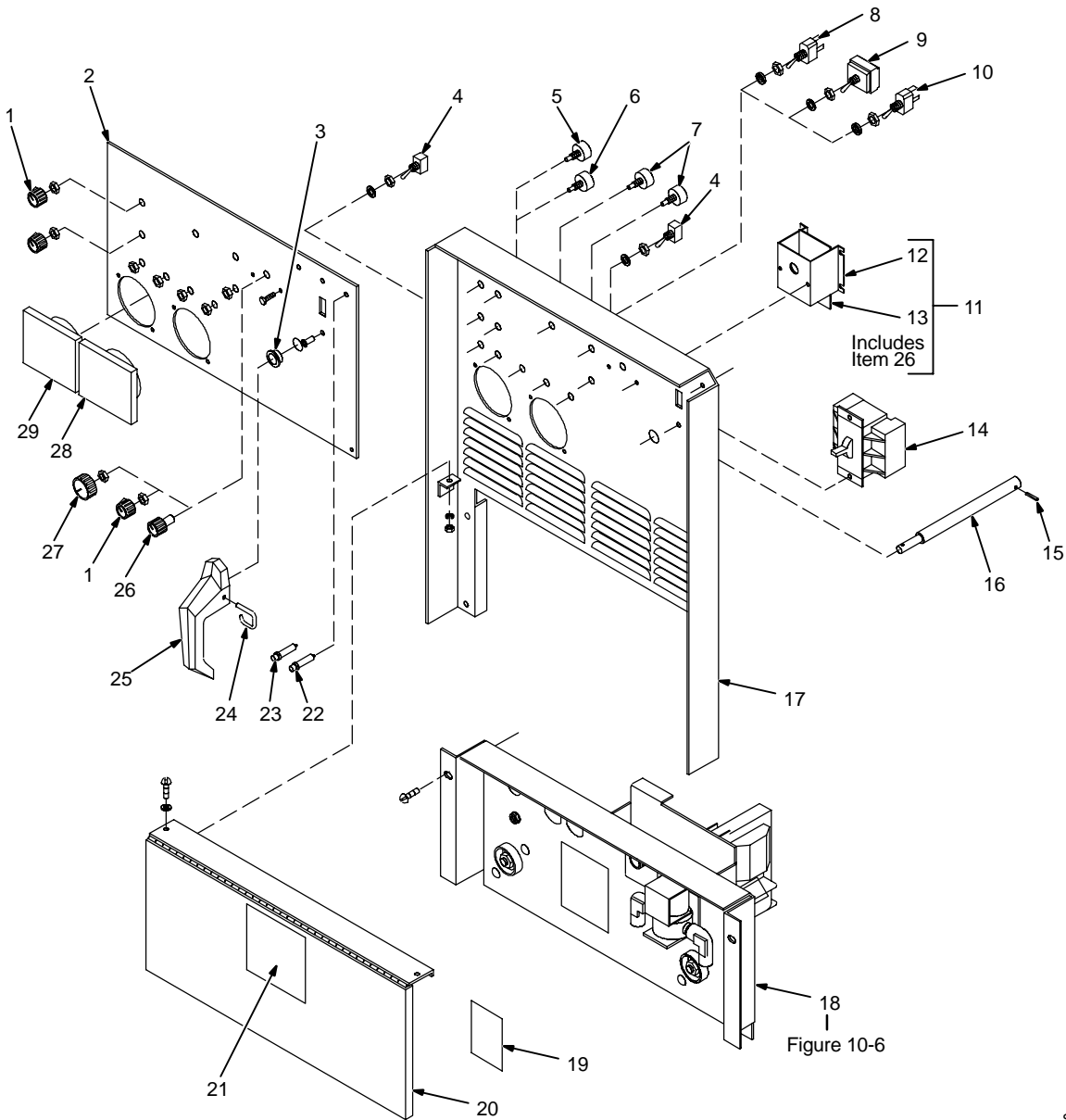

ST-120 088-G

Figure 10-2. Panel, Front w/Components

Item No.	Dia. Mkgs.	Part No.	Description	Quantity
----------	------------	----------	-------------	----------

Figure 10-2. Panel, Front w/Components (Fig 10-1 Item 29)

...	1	097 922	.. KNOB, pointer	3
...	2		NAMEPLATE, (order by model & serial number)	1
...	3	109 013	.. BUSHING, snap-in nyl .375 ID x .562mtg hole	1
...	4	S6,7	089 085 .. SWITCH, tgl SPST 20A 125VAC (Prior to KF988252)	2
...	4	S6,7	176 882 .. SWITCH, tgl SPST 20A 125VAC (Eff w/KF988252)	2
...		107 983	.. BLANK, snap-in nyl .500mtg hole	1
...		057 359	.. BLANK, snap-in nyl .375mtg hole	2
...	5	R3	030 109 .. POTENTIOMETER, C sltd sft 1/T 2W 5000 ohm	1
...	6	R11	030 684 .. POTENTIOMETER, C sltd sft 1/T 2W 5 meg ohm	1
...	7	R1,2	035 897 .. POTENTIOMETER, C sltd sft 1/T 2W 1000 ohm	2
...	8	S5	011 609 .. SWITCH, tgl SPDT 15A 125VAC	1
...	9	S3	052 769 .. SWITCH, tgl 4PDT 15A 125VAC	1
...	10	S2	011 610 .. SWITCH, tgl SPDT 15A 125VAC (Prior to JJ503984)	1
...	10	S2	088 409 .. SWITCH, tgl 2PDT 15A 125VAC (Eff w/JJ503984)	1
...	11	TD1	052 192 .. TIMER, delay on make - postflow (consisting of)	1
...	12		039 449 BRACKET, mtg - circuit card	1

Item No.	Dia. Mkgs.	Part No.	Description	Quantity
Figure 10-2. Panel, Front w/ Components (Continued)				
... 13		044 723	CIRCUIT CARD, postflow	1
... 14	S1	045 834	SWITCH, tgl DPST 60A 600VAC (Prior to KA759476)	1
... 14	S1	128 757	SWITCH, tgl DPST 60A 600VAC (Eff w/KA759476)	1
... 15		106 398	PIN, spring CS .156 x .625	1
... 16		114 721	SHAFT, extension switch (Prior to KA759476)	1
... 16		133 276	EXTENSION, handle switch (Eff w/KA759476 thru KF959378)	1
... 16		171 420	EXTENSION, handle switch (Eff w/KF959379)	1
... 17		164 481	PANEL, front (Prior to KF959379)	1
... 17		169 476	PANEL, front (Eff w/KF959379 thru KG170300)	1
... 17		181 096	PANEL, front (Eff w/KG170301)	1
... 18			CONTROL PANEL, lower front (Fig 10-6)	1
... 19		128 230	LABEL, warning electric shock etc	1
... 19		134 327	LABEL, warning electric shock etc CE	1
... 20		+114 759	DOOR, access front (Prior to KG170301)	1
... 20		+181 589	DOOR, access front (Eff w/KG170301)	1
...		605 583	CATCH, spring loaded door (Prior to KG170301)	1
... 21		134 327	LABEL, warning general precautionary	1
... 21		176 254	LABEL, warning general precautionary CE	1
... 22	PL2	157 958	LIGHT, ind wht lens 28V	1
... 23	PL1	155 500	LED, yellow (50 Hz model) (Eff w/ KG060803)	1
...	PLG5	135 635	CONNECTOR & SOCKETS	1
...	PLG6	131 054	CONNECTOR & SOCKETS	1
... 24		010 647	PIN, spring CS .156 x 1.250 (Prior to KF959379)	1
... 24		169 136	PIN, handle (Eff w/KF959379)	1
... 25		098 279	HANDLE, plrty/changeover switch (Prior to KF959379)	1
... 25		169 135	HANDLE, switch (Eff w/KF959379)	1
... 26		052 370	KNOB, indicator	1
... 27		097 924	KNOB, pointer	1
... 28		◆115 920	METER, amp AC/DC 100MV 0-300 scale	1
... 29		◆004 189	METER, volt AC/DC 0-100 scale	1

+When ordering a component originally displaying a precautionary label, the label should also be ordered.

◆OPTIONAL

BE SURE TO PROVIDE MODEL AND SERIAL NUMBER WHEN ORDERING REPLACEMENT PARTS.

Item No.	Dia. Mkgs.	Part No.	Description	Quantity
Figure 10-3. Rectifier, Si Diode (Fig 10-1 Item 2)				
1	C7-10	031 689	CAPACITOR, rectifier	4
2		083 884	CLAMP, thyristor rectifier (Prior to KG023560)	2
2		166 667	CLAMP, spring rectifier (Eff w/KG023560)	2
3	D1	037 956	DIODE, rect 275A 300V SP	1
4	TP3	168 898	THERMOSTAT, NC open 125°C (Eff w/KG170301)	1
5	SCR1-4	115 114	THYRISTOR, SCR 300A 300V	4
6		176 645	CLAMP, thyristor w/o thermostat (Eff w/KG023560)	2
6		173 714	CLAMP, thyristor with thermostat (Eff w/KG170030)	2
		028 516	PIN, spring CS .125 x .250	2
	PLG53	115 092	CONNECTOR & SOCKETS	1

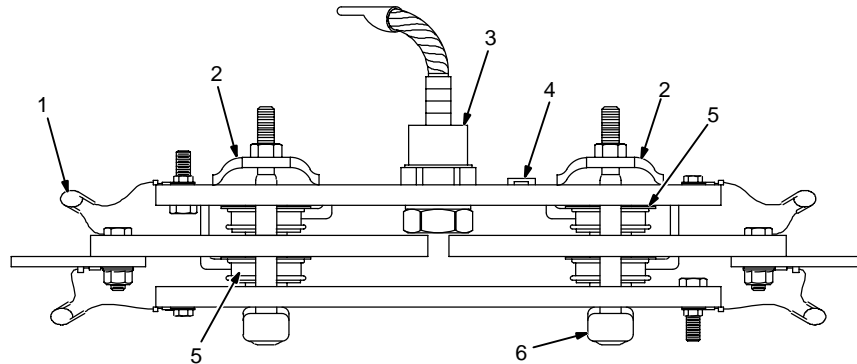

ST-120 205-A

Figure 10-3. Rectifier, Si Diode

Item No.	Dia. Mkgs.	Part No.	Description	Quantity
Figure 10-4. Panel, Rear w/Components (Fig 10-1 Item 17)				
1	R4	186 949	RESISTOR, WW fxd 175W 20 ohm	1
2		032 604	BLADE, fan 14 in 3 wing 19deg .375 bore CCW (Prior to KG198783)	1
2		180 165	BLADE, fan 14 in 3 wing 19deg .375 bore CCW (Eff w/KG198783)	1
3		114 752	PANEL, rear (Prior to KG170301)	1
3		181 099	PANEL, rear (Eff w/KG170301)	1
4		131 361	CHAMBER, plenum 14 in (Prior to KG128812)	1
4		173 283	CHAMBER, plenum 14 in (Eff w/KG128812) (50 Hz only)	1
5		124 274	BRACKET, mtg fan motor (Eff w/KG128812)	1
6	FM	116 190	MOTOR, 1/12 hp 230V 1550 RPM 50/60Hz 1.5A	1
		026 947	STAND-OFF, insul .250-20 x 1.000 lg (Prior to KB110695)	2
	Shunt	114 723	SHUNT, (Prior to KB110695)	1
		176 272	CONNECTOR, clamp cable (50 Hz model) (Eff w/KG060803)	1

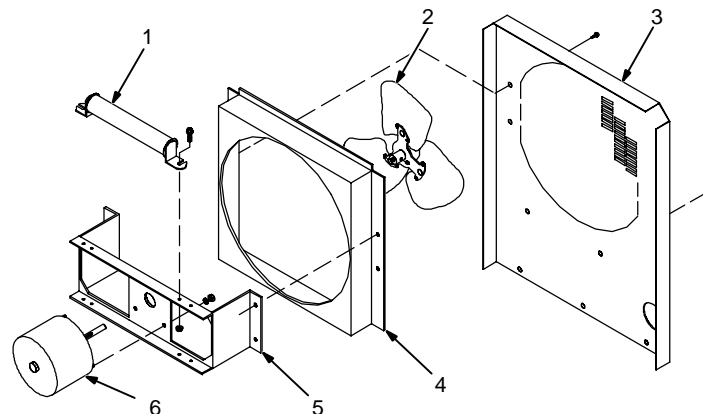

ST-120 089-F

Figure 10-4. Panel, Rear w/Components

BE SURE TO PROVIDE MODEL AND SERIAL NUMBER WHEN ORDERING REPLACEMENT PARTS.

Item No.	Dia. Mkgs.	Part No.	Description	Quantity
----------	------------	----------	-------------	----------

Figure 10-5. Panel, Mtg Components (Fig 10-1 Item 7)

.. 1	.. R7	.. 186 468	.. RESISTOR, WW fxd 100W 50 ohm	.. 1
.. 2		.. 117 721	.. PANEL, mtg relay	.. 1
.. 3	.. CR2,6	.. 110 386	.. RELAY, encl 24VAC DPDT	.. 2
.. 4	.. 2T	.. 072 253	.. STUD, single connection 10-32	.. 1
.. 5	.. SR2,3	.. 035 704	.. RECTIFIER, integ 40A 800V	.. 2
.. 6	.. SN1,2	.. 118 625	.. SNUBBER, poly metal film .5uf 200VDC 100 ohm	.. 2
.. 7	.. R6	.. 117 803	.. RESISTOR, WW fxd 10W 1K ohm	.. 1
.. 8	.. C20	.. 119 834	.. CAPACITOR, cer disc .05uf 500V	.. 1
.. 9	.. 1T	.. 117 372	.. BLOCK, term 10A 15P	.. 1
		.. 108 023	.. LINK, jumper term blk 10A	.. 3
.. 10	.. CR5	.. 000 770	.. RELAY, encl 24VDC 3PDT	.. 1
.. 11	.. CR1	.. 052 964	.. RELAY, encl 24VDC DPDT	.. 1

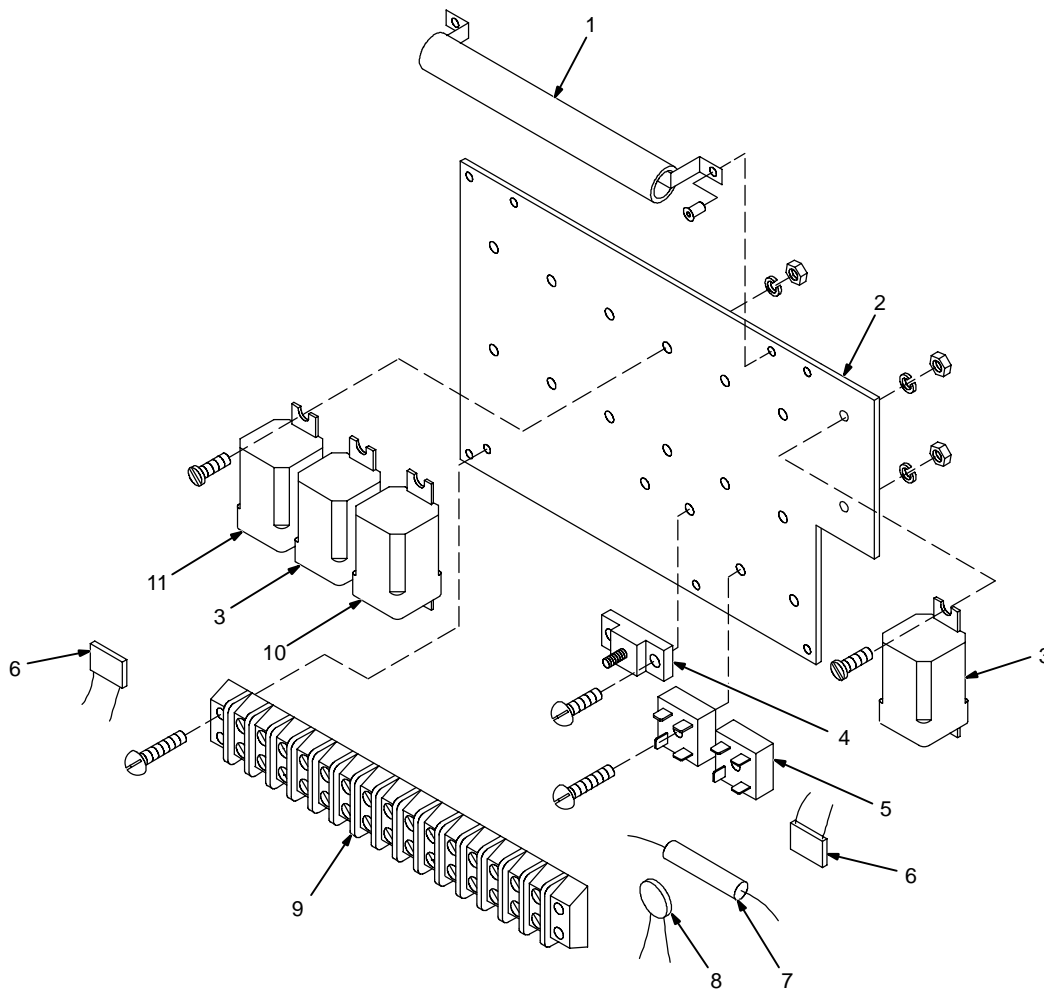

ST-120 090-F

Figure 10-5. Panel, Mtg Components

BE SURE TO PROVIDE MODEL AND SERIAL NUMBER WHEN ORDERING REPLACEMENT PARTS.

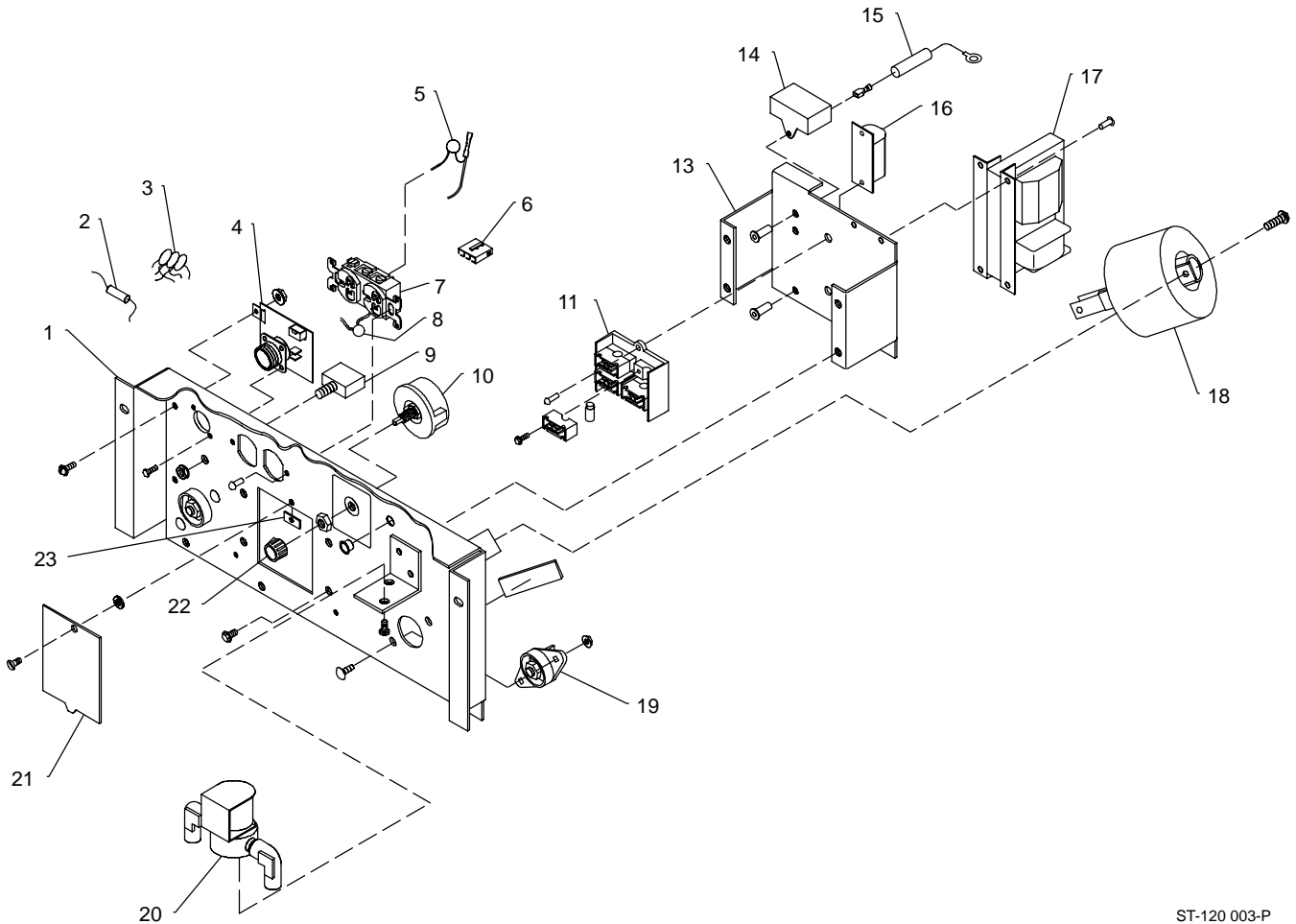

ST-120 003-P

Figure 10-6. Control Panel, Lower Front

Item No.	Dia. Mkgs.	Part No.	Description	Quantity
----------	------------	----------	-------------	----------

Figure 10-6. Control Panel, Lower Front (Fig 10-2 Item 18)

.....		116 477 ..	CONTROL PANEL, lower (Prior to JK572898)	1
.....		124 647 ..	CONTROL PANEL, lower (Eff w/JK572898 thru JK682712)	1
.....		131 217 ..	CONTROL PANEL, lower (Eff w/JK682714 thru JK690986)	1
.....		132 430 ..	CONTROL PANEL, lower (Eff w/JK690987 thru KA806713)	1
.....		137 516 ..	CONTROL PANEL, lower (Eff w/KA806713 thru KA877024)	1
.....		147 793 ..	CONTROL PANEL, lower (Eff w/KA877025 thru KF959378)	1
.....		174 067 ..	CONTROL PANEL, lower (Eff w/KF959379 thru KG170300)	1
.....		181 108 ..	CONTROL PANEL, lower (Eff w/KG170301)	1
... 1		114 742 ..	PANEL, lower front (Prior to JK572898)	1
... 1		124 784 ..	PANEL, lower front (Eff w/JK572898 thru JK690986)	1
... 1		130 582 ..	PANEL, lower front (Eff w/JK690987 thru KB093120)	1
... 1		147 795 ..	PANEL, lower front (Eff w/KB093121 thru KF959176)	1
... 1		171 652 ..	PANEL, lower front (Eff w/KF959177)	1
... 2	R25	137 429 ..	RESISTOR, C 2W 3.3K ohm (Eff w/KA806713)	1

Item No.	Dia. Mkgs.	Part No.	Description	Quantity
...	3	126 750	CAPACITOR ASSEMBLY, (Eff w/JK537589 thru JK690986)	1
...	3	C14 098 566	CAPACITOR, (Prior to JK537589)	1
...	3	C14 132 433	CAPACITOR, (Eff w/JK690987)	3
.....		121 270	RECEPTACLE/CAPACITOR, w/leads (Prior to JK682714) (consisting of)	1
.....	RC2	035 523	CONNECTOR, circ 5skt rcpt Amphenol MS-3102A-16S-8S	1
.....	C16-19	119 856	CAPACITOR	2
.....	PC2/RFC1	121 273	CIRCUIT CARD, snubber	1
.....		039 273	CONNECTOR, circ 5 pin size 16S plug Amphenol MS-3106A-16S-8P	
.....		039 685	CONNECTOR, circ clamp str rlf size 16 Amphenol 97-3057-8	
.....		142 523	CONNECTOR/CAPACITOR, w/leads (Eff w/JK674521 thru KF959378) (consisting of)	1
.....	RC2	143 976	CONNECTOR w/SOCKETS	1
.....	C16	143 899	LEAD ASSY, elect	1
.....	C17	143 897	LEAD ASSY, elect	1
.....	C18	143 898	LEAD ASSY, elect	1
.....	C19	143 900	LEAD ASSY, elect	1
.....	RFC1/PC2	142 522	CHOKE	1
...	4	PC2/RC1 157 959	CIRCUIT CARD ASSEMBLY, (Eff w/KF959379) (consisting of)	1
.....		PLG21 153 501	CONNECTOR & SOCKETS	1
.....		134 734	CONNECTOR, circ 14 pin size 20 plug Amp 213571-2	
.....		079 534	CONNECTOR, circ skt push-in 14-18ga Amp 66358-6	
.....		079 739	CONNECTOR, circ clamp str rlf size 17-20 Amp 206322-2	
...	5	C6 164 290	CAPACITOR, polyp film 3.5uf 600VDC	1
...	6	PLG3 131 204	CONNECTOR & SOCKETS	1
...	7	RC2 604 176	RECEPTACLE, straight duplex grd 2P3W 15A 125V	1
.....		073 690	CAP, straight P & S 2P3W 5266 DF	
...	8	C15 170 920	CAPACITOR	1
...	9	CB1 093 995	CIRCUIT BREAKER, man reset 1P 15A 250V	1
...	10	R13 605 828	RHEOSTAT, WW 50W 1.5 ohm (Prior to KG170301)	1
...	10	R13 174 037	RHEOSTAT, WW 50W 1.5 ohm (Eff w/KG170301 thru LA292998)	1
...	10	R13 198 547	RHEOSTAT, WW 25W 1.5 ohm (Eff w/LA292999)	1
.....		010 493	BUSHING, snap-in nyl .625 ID x .875 mtg hole	1
...	11	G ♦♦020 623	SPARK GAP ASSEMBLY (Prior to LA337284)	1
.....		♦♦095 621	BASE, spark gap (Prior to LA337284)	1
.....		♦♦020 622	HOLDER, points (Prior to LA337284)	4
.....		♦♦*020 603	POINT, spark gap (Prior to LA337284)	4
...	11	G ♦♦203 419	SPARK GAP ASSEMBLY SERVICE KIT (for units prior to LA337284))	1
...	11	G ♦♦199 854	SPARK GAP ASSEMBLY (Eff w/LA337284)	1
.....		♦♦199 855	BASE, spark gap (Eff w/LA337284)	1
.....		♦♦199 856	HOLDER, points (Eff w/LA337284)	4
.....		♦♦*196 455	POINT, spark gap (Eff w/LA337284)	4
.....		088 731	BUSHING, snap-in nyl .375 ID x .500mtg hole	2
...	12	097 712	STRIP, insulator	1
...	13	174 070	BRACKET, mtg components (Eff w/KG959379)	1
...	14	C3 106 935	CAPACITOR, polyp film 10uf 250VAC (Prior to KK001554)	1
...	14	C3 191 944	CAPACITOR, polyp film 10uf 250VAC (Eff w/KK001554)	1
...	15	R8 083 784	RESISTOR, WW fxd 100W 10 ohm (Prior to KG170301)	1
...	15	R8 181 107	RESISTOR ASSEMBLY w/LEADS, (Eff w/KG170301)	1
...	16	C4 096 761	CAPACITOR, mica .002uf 10000V (CE Models Only)	1
...	16	C4 096 761	CAPACITOR, mica .002uf 10000V (Prior to KK001554 for nonCE Models)	1
...	16	C4 201 197	CAPACITOR, polyp met film .002uf 10000VDC/4400VAC pnl mtg (Eff w/KK001554 for nonCE Models)	1
.....		000 681	STRIP, mtg HF coil (Prior to JK572898)	1
.....		124 649	STRIP, mtg HF coil (Eff w/JK572898)	1
.....		000 682	TUBING, fiber vulc .250 ID x .312 OD x .812 (Prior to JK572898)	2
.....		125 949	TUBING, fiber vulc .250 ID x .312 OD x 1.125 (Eff w/JK572898)	2
...	17	T2 074 398	TRANSFORMER, high voltage 115V pri 3600V sec 30mA	1

Item No.	Dia. Mkgs.	Part No.	Description	Quantity
Figure 10-6. Control Panel, Lower Front (Fig 10-2 Item 18) (Continued)				
... 18	T3	115 967	.. COIL, HF coupling (Prior to JK572898)	1
... 18	T3	124 650	.. COIL, HF coupling (Eff w/JK572898 thru KF959378)	1
... 18	T3	174 692	.. COIL, HF coupling (Eff w/KF959379)	1
.....	R9	030 603	.. RESISTOR, WW fxd 10W 10K ohm (Prior to KA877025)	1
... 19	Work			
	Electrode	039 047	.. TERMINAL, power output (consisting of)	2
		601 976 SCREW, stl hexhd .500-13 x 1.500	1
		039 049 TERMINAL BOARD, red	1
		601 880 NUT, stl hex jam .500 -13	1
		039 044 BUS BAR, term bd	1
		601 879 NUT, stl hex full fnsh .500-13	1
... 20	GS1	174 036	.. VALVE, w/fittings & leads (consisting of)	1
		010 296 FITTING, hose brs elbow M 1/4NPT x .625-18	2
		035 601 VALVE, 115VAC 2 way 1/4 IPS port 1/8 orf	1
	PLG4	131 203	.. CONNECTOR & SOCKETS	1
... 21		174 038	.. PANEL, door access HF (Eff w/KF959379)	1
... 22		097 922	.. KNOB, pointer (Eff w/JK572898)	1
... 23		010 357	.. SPEED NUT	1
... 24		605 742	.. CLIP, mtg resistor .500 ID core	2

***Recommended Spare Parts**

◆◆ Effective with Serial No. LA337284, Spark Gap Assembly 020 623 consisting of: Base 095 621, Holder 020 622, and Points 020 603, is no longer available. If replacement parts are needed for any units with a Serial No. prior to LA337284, you must first order and install Spark Gap Assembly Service Kit 203 419. To replace spark gap parts in units with Serial No. LA337284 and following, or for units with Spark Gap Assembly Service Kit 203 419 installed, order appropriate spark gap parts listed above as, eff/w Serial No. LA337284.
BE SURE TO PROVIDE MODEL AND SERIAL NUMBER WHEN ORDERING REPLACEMENT PARTS.

Eff w/KE558763 the Water Valve Option (042 138) is no longer available
and all other options are available as Field Options only.

Dia. Mkgs.	Part No.	Description	Quantity
Optional Equipment			
	042 138	.. WATER VALVE, (consisting of)	1
WSI	035 601 VALVE, 115VAC 2 way 1/4 IPS port 1/8 orf	1
	010 295 FITTING, pipe brs elbow M 1/4NPT x .625-18	2
	116 201 BRACKET, mtg valve	1
	042 140	.. METER KIT, (consisting of)	1
A	115 920 METER, amp AC/DC 100MV 0-300 scale	1
V	004 189 METER, volt AC/DC 0-100 scale	1
	131 054 CONNECTOR & SOCKETS, (consisting of)	1
	113 746 CONNECTOR, rect skt 24-18ga Molex 39-00-0038	8
	042 142	.. SPOT TIMER, (consisting of)	1
CR3	006 393 RELAY, encl 24VAC DPDT	1
RFC,VR1/PC3	120 875 CIRCUIT CARD, snubber	1
R10	030 108 POTENTIOMETER, C sltd sft 1/T 2W 100K ohm	1
S8	011 611 SWITCH, tgl DPDT 15A 125V	1
TD2	047 133 RELAY, delay adj 120VAC DPDT	1
	097 922 KNOB, pointer	1
	042 144	.. PRE-FLOW TIMER, (consisting of)	1
CR4	006 393 RELAY, encl 24VAC DPDT	1
R12,S9	115 862 POTENTIOMETER, C sltd sft 1/T .50W 500K ohm	1
TD3	116 476 TIMER, delay on make - preflow (consisting of)	1
	115 856 CIRCUIT CARD, preflow (consisting of)	1
A50	008 971 IC, linear 741	1
C50	039 482 CAPACITOR, elctlt 100uf 35VDC	1
C51	091 378 CAPACITOR, tantlm 33uf 35VDC	1
C52	039 481 CAPACITOR, elctlt 3.3uf 50VDC	1
C53	031 677 CAPACITOR, elctlt 5.6uf 35VDC	1
C54	166 199 CAPACITOR, cer disc .05uf 500VDC	1
CR50	039 486 RELAY, encl 24VDC SPDT 2.5A	1
D50,51	026 202 DIODE, rect 1A 400V SP	2
Q50	000 088 TRANSISTOR, NPN 800mA 400V	1
R50	074 121 RESISTOR, C 2W 3.3K ohm	1
R52	108 432 RESISTOR, MF .25W 2.21K ohm	1
R53	000 342 POTENTIOMETER, cermet trmr 1/T .5W 5K ohm	1
R54	093 030 RESISTOR, MF .25W 15K ohm	1
R55	028 273 RESISTOR, C .5W 2.7K ohm	1
R56	093 037 RESISTOR, MF .25W 47.5K ohm	1
R57	605 919 RESISTOR, C .25W 47 ohm	1
	039 449 BRACKET, mtg circuit card	1
	097 922 KNOB, pointer	1
	042 353	.. POWER FACTOR CORRECTION, (consisting of)	1
C1	125 781 CAPACITOR, polyp film 150uf 250VAC	4
	129 201 BRACKET, mtg capacitor	2

Call
1-800-4-A-
MILLER
for your local
Miller distribu-
tor.

Miller Electric Mfg. Co.

An Illinois Tool Works Company
1635 West Spencer Street
Appleton, WI 54914 USA

International Headquarters—USA

Phone: 920-735-4505
USA & Canada FAX: 920-735-4134
International FAX: 920-735-4125

**European Headquarters –
United Kingdom**

Phone: 44 (0) 1204-593493
FAX: 44 (0) 1204-598066