

MINDEO

MS3590 Programmable Mobile Scanner

User Manual



Version: MS3590_UM_EN_V1.0.3

Notice

Before operating this mobile scanner, please make sure you carefully read the following information to ensure that your scanner is able to perform at the level for which it is designed.

1. All software, including firmware, furnished to the user is on a licensed basis.
2. The right is reserved to make changes to any software or product to improve reliability, function, or design.
3. The contents of this manual are subject to change without notice.
4. The manufacturer assumes no responsibility for any loss or claims by third parties which may arise from the use of this manual.
5. Do not throw or drop the scanner or otherwise subject it to strong impact, which can damage the scanner, interrupt program execution, corrupt memory contents, or otherwise interfere with proper operation.
6. A standard packing includes a mobile scanner, a USB cable and a CD (containing software and electrical manuals). Accessory includes a Bluetooth USB adapter BA2110 which supports reliable wireless data transmission and an AC/DC adaptor for battery charge.
7. **Please charge the battery before the first time of use.**
8. The term “scanner” as used in this manual denotes the MS3590 mobile scanner unless otherwise noted.

Contents

| | |
|------------------------------------------------------|-----------|
| Notice | ii |
| 1 Specifications | 1 |
| 1-1 Technical specifications | 1 |
| 1-2 Default settings for each barcode..... | 3 |
| 1-3 Dimensions | 4 |
| 1-5 Parts of the scanner..... | 5 |
| 1-6 Parts of the Bluetooth USB adapter BA2110..... | 6 |
| 1-7 Keys introduce..... | 7 |
| 2 Introduction to installation | 8 |
| 2-1 Installing a USB HID keyboard wired scanner..... | 8 |
| 2-2 Installing a USB virtual COM wired scanner..... | 8 |
| 2-3 Attaching the neck/wrist strap | 9 |
| 2-4 Replacing the Lithium-ion battery | 9 |
| 3 Getting started | 10 |
| 3-1 Power on/off scanner..... | 10 |
| 3-2 Charge battery..... | 10 |
| 3-3 Enter/Exit sleep mode | 10 |
| 3-4 Power on/off Bluetooth | 10 |
| 4 Introduction to LCD display | 11 |
| 4-1 LCD display icons | 11 |
| 4-2 LCD display menu..... | 12 |
| 5 Operations of the scanner | 16 |
| 5-1 Scan | 16 |
| 5-1-1 Scan Mode..... | 16 |
| 5-1-2 Input Data Manually | 16 |
| 5-1-3 Quantity Enter | 17 |
| 5-1-4 Add Time..... | 17 |
| 5-1-5 Add Date | 18 |
| 5-1-6 Set Separator | 18 |
| 5-1-7 Database Query..... | 18 |
| 5-1-8 Avoid Duplication | 19 |
| 5-1-9 Barcode Statistics..... | 19 |
| 5-1-10 Sum Total | 19 |
| 5-1-11 List Files..... | 19 |
| 5-1-12 Transfer Confirm..... | 20 |
| 5-2 Data Transfer | 21 |
| 5-2-1 Bluetooth..... | 21 |
| 5-2-2 USB HID keyboard | 21 |

| | |
|-----------------------------------------------------------------------|-----------|
| 5-2-3 USB Virtual COM..... | 21 |
| 5-2-4 U Disk..... | 21 |
| 5-2-5 Data Batch..... | 22 |
| 5-3 System Setting | 23 |
| 5-3-1 Bluetooth..... | 23 |
| 5-3-2 USB HID Keyboard | 30 |
| 5-3-3 Language..... | 30 |
| 5-3-4 Volume of Beeper..... | 30 |
| 5-3-5 Vibrator..... | 31 |
| 5-3-6 Backlight timeout | 31 |
| 5-3-7 Sleep timeout | 31 |
| 5-3-8 Time and Date..... | 31 |
| 5-3-9 Default setting | 31 |
| 5-3-10 System password | 31 |
| 5-4 System Information..... | 32 |
| 5-4-1 View Memory..... | 32 |
| 5-4-2 Bluetooth..... | 32 |
| 5-4-3 Firmware Version..... | 32 |
| 6 User customized application software for MS3590..... | 33 |
| 6-1 Auto Run..... | 33 |
| 6-2 Execute..... | 33 |
| 6-3 Download..... | 33 |
| 6-4 Installation key for deciphering encrypted file..... | 34 |
| 6-5 Verification code for user customized application software..... | 34 |
| 7 Barcode programming instructions | 35 |
| 7-1 Single-parameter setting by scanning 1D barcodes..... | 35 |
| 7-2 Decode illumination and decode aiming pattern | 36 |
| 7-3 DPM, Multiple symbols, Structured append, etc. read setting | 37 |
| 7-4 Global settings..... | 41 |
| 7-5 UPC-A..... | 45 |
| 7-6 UPC-E..... | 47 |
| 7-7 UPC-E1..... | 49 |
| 7-8 EAN-13 (ISBN/ISSN)..... | 51 |
| 7-9 EAN-8 | 53 |
| 7-10 Code 39 (Code 32, Trioptic Code 39)..... | 55 |
| 7-11 Interleaved 2 of 5 | 58 |
| 7-12 Industrial 2 of 5 (Discrete 2 of 5) | 60 |
| 7-13 Matrix 2 of 5 | 61 |
| 7-14 Codabar..... | 62 |

| | |
|-------------------------------------------------------------|------------|
| 7-15 Code 128..... | 64 |
| 7-16 UCC/EAN 128 | 66 |
| 7-17 ISBT 128 | 68 |
| 7-18 Code 93 | 69 |
| 7-19 Code 11 | 70 |
| 7-20 MSI/Plessey | 72 |
| 7-21 UK/Plessey | 74 |
| 7-22 China Post..... | 75 |
| 7-23 GS1 DataBar (GS1 DataBar Truncated)..... | 76 |
| 7-24 GS1 DataBar Limited | 77 |
| 7-25 GS1 DataBar Expanded | 78 |
| 7-26 China Finance | 79 |
| 7-27 PDF417 | 81 |
| 7-28 MicroPDF417..... | 82 |
| 7-29 QR Code | 83 |
| 7-30 Data Matrix..... | 84 |
| 7-31 Han Xin Code | 85 |
| 7-32 Aztec Code | 86 |
| 7-33 G1-G6 & C1-C3 & FN1 substitution string setting | 87 |
| 7-34 G1-G4 string position & Code ID position | 92 |
| 7-35 String transmission | 93 |
| 8 Test Chart..... | 96 |
| 9 ASCII Table..... | 99 |
| 10 Barcode representing non-printable character..... | 100 |
| 11 Configuration alphanumeric entry barcode..... | 101 |

1 Specifications

1-1 Technical specifications

Table 1-1 Technical specifications of the scanner

| | |
|---------------------------|-------------------------------------------------------------------------------------------------------------------------------------------------------------------------------------------------------------------------------------------------------------------------------------------------------------------------------------------------------------------------------------------------------------------------------------------------------|
| Data storage | 16 MB for out of range batch/data batch mode: 1,118,480 barcodes (each barcode is of 15 bytes); 96 MB for U Disk mode: 1,509,949,440 barcodes (each barcode is of 15 bytes). |
| Radio link | 2.4 ~ 2.5GHz (ISM band), Bluetooth V2.1+EDR |
| Working range | 30 meters (line of sight) |
| Interface | Bluetooth scanner: Human Interface Device (HID) Keyboard Serial Port Profile (SPP), operating as either a master or a slave USB wired scanner: USB HID keyboard USB virtual COM U Disk (with which barcode data is stored in a txt file rather than sent to a host via Bluetooth/USB) |
| Keyboard layout | USA, Turkish F/Q, French, Italian, Spanish, Slovak, Denmark, Japanese, German |
| Dimensions | Length × Width × Depth: 12.5 × 4.6 × 3.1 cm |
| Weight | 128g |
| Color | White/Black/Grey/Customization |
| Battery | 1900 mAh Lithium-ion battery |
| Charge time | Fully charged (>80%) in 4 hours |
| Charge current | 500 mA |
| Case material | ABS |
| Image size | 838 × 640 pixels |
| Scanning angle | ±60°, ±40°, 360° (Skew, Pitch, Roll) |
| Decode capability | 1D: UPC-A, UPC-E, UPC-E1, EAN-13, EAN-8, ISBN (Bookland EAN), ISSN, Code 39, Code 39 full ASCII, Code 32, Trioptic Code 39, Interleaved 2 of 5, Industrial 2 of 5 (Discrete 2 of 5), Matrix 2 of 5, Codabar (NW7), Code 128, UCC/EAN 128, ISBT 128, Code 93, Code 11 (USD-8), MSI/Plessey, UK/Plessey, China Post, China Finance, GS1 DataBar (formerly RSS) variants 2D: PDF417, MicroPDF417, QR Code, DataMatrix, Han Xin Code, Aztec Code |
| Indicator | Beeper, LED, Vibrator |
| Display | LCD monochrome display (128 × 64) with LED backlight |
| Operating mode | Handheld |
| Programming method | Manual (reading special barcode), On-Screen (pressing special keys) |
| Firmware upgrade | Online via USB interface |
| Temperature | -20° to 55°C (-4° to 131°F), Operating; -40° to 70°C (-40° to 158°F), Storage |
| Humidity | 5% to 95% (non-condensing) |

| | |
|--------------------------|-------------------------------------------------------------------------------------------------------------------------------------------------------------------------------------------------------------------------------------------------------------------------------------------------|
| Input Voltage | 4.75V – 5.25V |
| Operating current | 5mA (sleeping); 350mA (scanning); 360mA (transmitting) |
| Standby time | Over 7 days |
| Operating time | 5.5 hours |
| Decoding depth | 3.5mil Code128 (9 chars): 1.5cm – 3.5cm 5mil Code39 (20 chars): 0.8cm – 5.5cm 13mil UPC (12 chars): 0.7cm – 16.5cm 20mil Code39 (5 chars): 3.5cm – 21.0cm 6.7mil PDF417 (20 chars): 0.0cm – 7.5cm 10 mil DM (20 chars): 0.0cm – 11.5cm 20 mil QR (20 chars): 0.0cm – 19.5cm |

Table 1-2 Technical specifications of BA2110

| | |
|----------------------|------------------------------------------------------|
| Radio link | 2.4 ~ 2.5GHz (ISM band), Bluetooth V2.1+EDR, class 2 |
| Working range | 30 meters (line of sight) |
| Dimensions | Length × Width × Depth: 7.6 × 2.2 × 0.8 cm |
| Weight | 12g |

Notes:

- 1- BA2110 is a Bluetooth USB adapter made by the manufacturer, which supports reliable wireless data transmission.
- 2- BA2110 is an optional accessory.

1-2 Default settings for each barcode

Table 1-3 Default setting for each barcode

| Code type | Read enable | Check digit verification | Check digit transmission | Min. code length | Proprietary code ID | AIM code ID |
|-----------------------------------------|-------------|--------------------------|--------------------------|-------------------|---------------------|-------------|
| UPC-A | √ | √ | √ | (12) ² | A |]Em |
| UPC-E | √ | √ | √ | (8) ² | D |]Em |
| UPC-E1 | √ | √ | √ | (8) ² | D |]Em |
| EAN-13 | √ | √ | √ | (13) ² | A |]Em |
| EAN-8 | √ | √ | √ | (8) ² | C |]Em |
| ISBN (Bookland EAN) / ISSN ¹ | √ | √ | √ | (13) ² | B |]Em |
| Code 39 | √ | - | - | 1 | M |]Am |
| Interleaved 2 of 5 | √ | - | - | 6 | I |]Im |
| Industrial 2 of 5 | - | - | - | 4 | H |]Im |
| Matrix 2 of 5 | √ | - | - | 6 | X |]Im |
| Codabar | √ | - | - | 4 | N |]Fm |
| Code 128 | √ | √ | - | 1 | K |]Cm |
| UCC/EAN 128 | √ | √ | - | 1 | K |]Cm |
| ISBT 128 | √ | √ | - | 1 | K |]Cm |
| Code 93 | √ | √ | - | 1 | L |]Gm |
| Code 11 | - | √ | - | 4 | V | - |
| MSI/Plessey | - | - | - | 4 | O |]Mm |
| UK/Plessey | - | √ | - | 1 | U |]Mm |
| China Post | √ | - | - | (11) ² | T |]Im |
| China Finance | √ | - | - | (10) ² | Y | - |
| GS1 DataBar | √ | - | - | (16) ² | R |]em |
| GS1 DataBar Truncated ³ | √ | - | - | (16) ² | R |]em |
| GS1 DataBar Limited | √ | - | - | (16) ² | R |]em |
| GS1 DataBar Expanded | √ | - | - | 1 | R |]em |
| PDF417 | √ | - | - | - | - | - |

| Code type | Read enable | Check digit verification | Check digit transmission | Min. code length | Proprietary code ID | AIM code ID |
|--------------|-------------|--------------------------|--------------------------|------------------|---------------------|-------------|
| MicroPDF417 | √ | - | - | - | - | - |
| DataMatrix | √ | - | - | - | - | - |
| QR code | √ | - | - | - | - | - |
| Han Xin Code | √ | - | - | - | - | - |
| Aztec Code | √ | - | - | - | - | - |

Note: ¹The settings for ISBN/ISSN and EAN-13 must be the same except the code ID.

² Fixed-length barcodes.

³The settings for GS1 DataBar Truncated and GS1 DataBar must be the same.

1-3 Dimensions

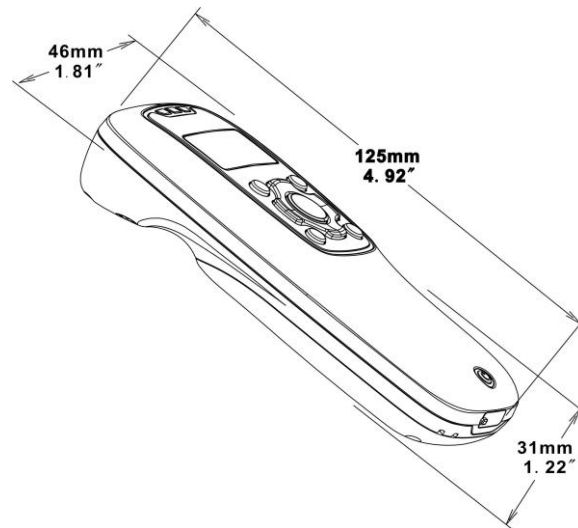

Figure 1-1 Dimensions of the scanner

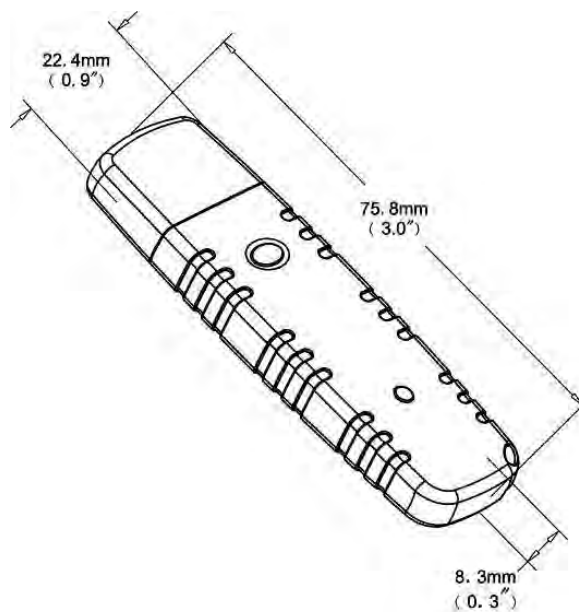

Figure 1-2 Dimensions of the Bluetooth USB adapter

1-5 Parts of the scanner

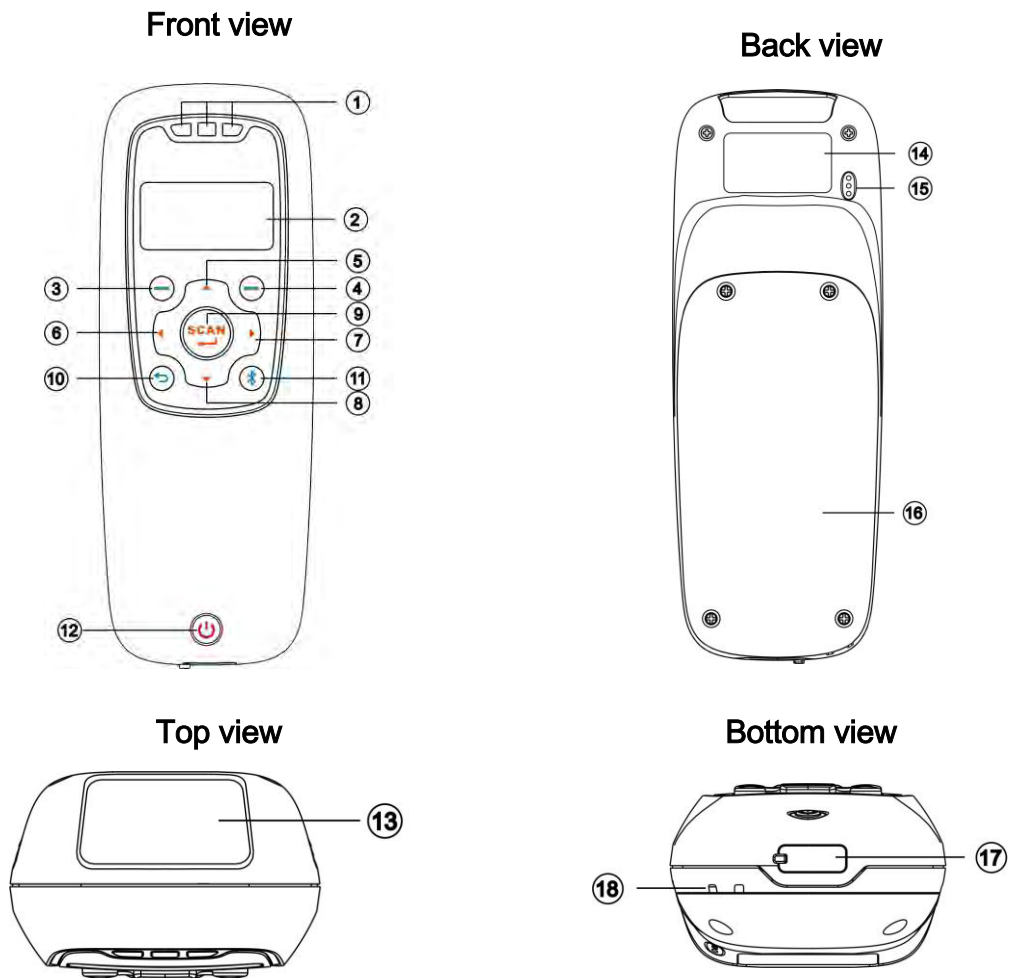

Figure 1-3 Parts of the scanner

- ① Blue LED (Bluetooth power); Green LED (Decode success); Red LED (Charging indicator)
- ② LCD
- ③ Left soft key
- ④ Right soft key
- ⑤ Up navigation key
- ⑥ Left navigation key
- ⑦ Right navigation key
- ⑧ Down navigation key
- ⑨ Scan/Select key
- ⑩ Return key
- ⑪ Bluetooth on/off key
- ⑫ Power/Sleep key
- ⑬ Scan window
- ⑭ Label
- ⑮ Beeper
- ⑯ Battery cover
- ⑰ Mini USB port / Battery charging port (Lift cover)
- ⑱ Hook for neck/wrist strap

1-6 Parts of the Bluetooth USB adapter BA2110

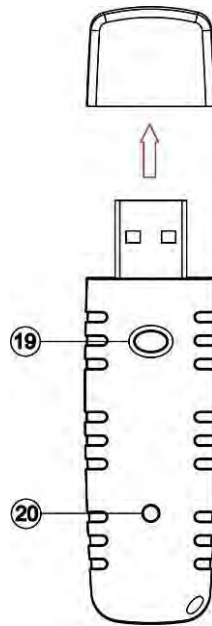

Figure 1-4 Parts of the Bluetooth USB adapter BA2110

- ①⑨ Reset/Firmware upgrade key
- ②⑩ Green LED (Power/Data transmission)

1-7 Keys introduce

Operations, such as scrolling and selecting menus, moving a cursor, or scanning a barcode, are controlled by trigger keys and stroke keys.

Table 1-4 Key functions

| Part Position¹ | Key/Action/Feature | Description |
|----------------------------------|---------------------------|--------------------------------------------------------------------------------------------------------------------------------------------------|
| ③ | Left soft key | Functionalities are identified by the screen display. In general, the acknowledge/non-acknowledge of operations are done by pressing a soft key. |
| ④ | Right soft key | |
| ⑨ | Scan/Select key | Pressed to scan barcodes when the scanner is not in a menu status; the select key is pressed to select items when a menu is activated. |
| ⑤ | Up navigation key | Pressed to move cursor upward/downward. |
| ⑧ | Down navigation key | |
| ⑥ | Left navigation key | Pressed to move cursor leftward/rightward. |
| ⑦ | Right navigation key | |
| ⑩ | Return key | Pressed to return to previous menu by one step. |
| ⑪ | Bluetooth on/off key | Pressed to turn on/off the Bluetooth power. |
| ⑫ | Power/Sleep key | Pressed long to power on/off a scanner; the key is pressed short to enter/exit sleep mode. |

Note: ¹See **Parts of the scanner** for the information about position of keys.

2 Introduction to installation

2-1 Installing a USB HID keyboard wired scanner

Note: The default interface of the scanner is BT HID Keyboard. Please change the interface to USB HID Keyboard (See “[5-2 Data Transfer](#)”).

1. Refer to Figure 2-1, plug one end of the USB cable to the scanner. Plug the other end into the USB port of the computer.
2. For example: Using Microsoft Windows operation system, the system gives message on “new hardware found – USB HID input device found”, then driver will be installed on request.
3. After successfully installing the new hardware, message will be given: “hardware installed successfully and ready to use”.
4. If any problem is encountered during the installation process, unplug the USB cable from the computer and repeat step 1-2.

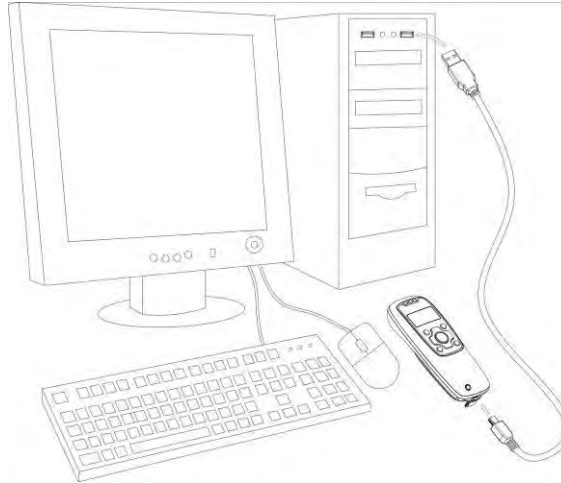

Figure 2-1 Diagram of connecting the scanner to PC

2-2 Installing a USB virtual COM wired scanner

Note: The default interface of the scanner is BT HID Keyboard. Please change the interface to USB Virtual COM.

1. Refer to Figure 2-1, plug one end of the USB cable to the scanner. Plug the other end into the USB port of the computer.
2. For example: Using Microsoft Windows operation system, the system gives message on “new hardware found – USB Virtual COM found” for USB virtual COM, then driver will be installed on request.
3. After successfully installing the new hardware, message will be given: “hardware installed successfully and ready to use”.
4. If any problem is encountered during the installation process, unplug the USB cable from the computer and repeat step 1 to step 2.

2-3 Attaching the neck/wrist strap

Note: The neck/wrist strap protects the scanner from being damaged as a result of it being dropped by mistake during movement.

1. Refer to Figure 2-2, remove the 3 screws from the battery cover (one at a time).
2. Attach the neck/wrist strap by hanging the strap ring around the raised part at the corner.
3. Screw in the 3 screws to tighten the scanner and the battery cover.

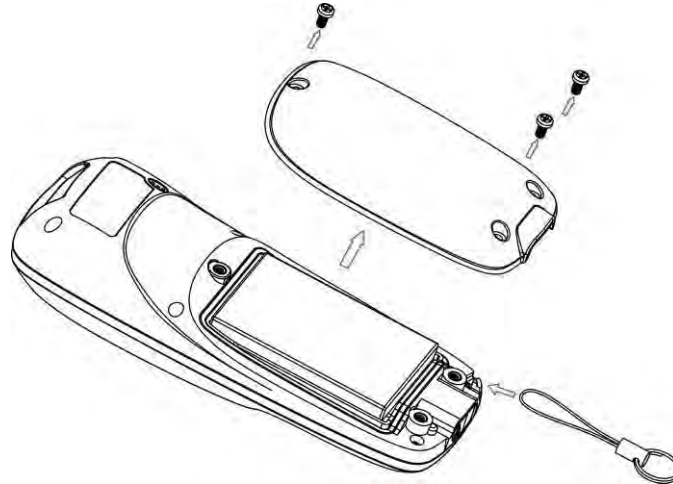

Figure 2-2. Diagram of attaching the neck/wrist strap

2-4 Replacing the Lithium-ion battery

1. Refer to Figure 2-2, remove the 3 screws from the battery cover (one at a time).
2. Refer to Figure 2-3, load the battery while sliding it with the connection on the battery pack on the scanner body.
3. Replace the battery cover, screw in the 3 screws to tighten the scanner and the battery cover.

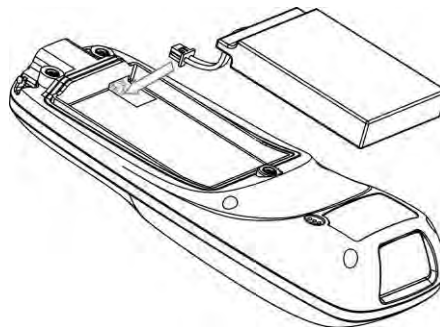



Figure 2-3. Diagram of replacing the Lithium-ion battery

3 Getting started

3-1 Power on/off scanner

Power on scanner: Press the Power/Sleep key  (see Parts of the scanner) for two seconds.

Power off scanner: Press the Power/Sleep key  (see Parts of the scanner) for two seconds.

3-2 Charge battery

1. **Please charge the battery before the first time of use.** There are two methods of charging battery as demonstrated in Figure 3-1. The charging indicator (red LED) on the scanner is turned on when the charging is in process. When the charging process completes, the red LED is turned off.
2. Charging time: 3.5 hours for fully charged.
3. In scanning status, the icon  is seen at the top of the screen display when the scanner is connected to a PC with the USB cable.

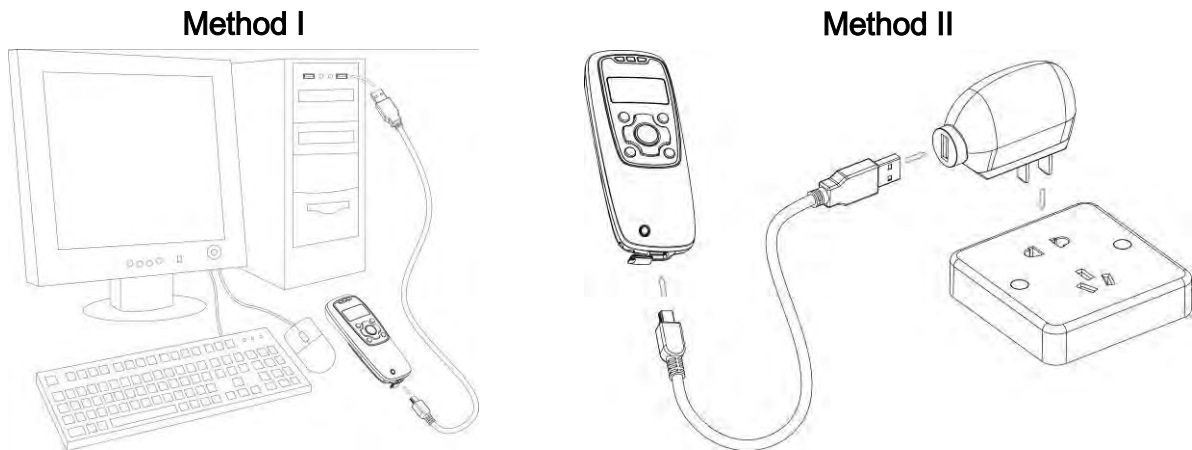

Figure 3-1 Diagram of charging battery

3-3 Enter/Exit sleep mode



Enter sleep mode: Press the Power/Sleep key  (see **Parts of the scanner** ⑫) for 0.5 seconds.

Exit sleep mode: Press the Power/Sleep key  for 0.5 seconds.

3-4 Power on/off Bluetooth

Bluetooth indicator:

In scanning status, the status of the Bluetooth is shown by icons.

| | |
|-------------------------------------------------------------------------------------|-------------------|
|  | Bluetooth is on. |
|  | Bluetooth is off. |

The status of the Bluetooth is also indicated by the blue LED.

| | |
|-----|-------------------|
| on | Bluetooth is on. |
| off | Bluetooth is off. |

Power off Bluetooth:

Press the Bluetooth key  (see “1-5 Parts of the scanner”).

Power on Bluetooth:

Press the Bluetooth key .





4 Introduction to LCD display

4-1 LCD display icons

Notes:

- 1- The LCD screen is designed to display barcode scanning, Bluetooth network establishing, data transfer, system setting and other information.
- 2- The display area is 64 dots (V) by 128 dots (H). The backlight will be switched off automatically if time of no operation exceeds a programmable duration (see System Setting→Backlight Timeout).

Table 4-1 LCD display icons

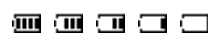
| Icon | Description |
|-------------------------------------------------------------------------------------|-----------------------------------------------------------------------------------------------------------------------------------------------------------------------------------------------------------------------------------------------------------------------------------------------------------------------------------------------------------------------------------------------------------|
|  | Bluetooth network is working. |
|  | Bluetooth network is disconnected. |
|  | Bluetooth module is on. |
|  | Bluetooth module is off. |
|  | Scanner is connected to a PC (or other instrument) with USB cable. |
|  | Battery capacity (from the left): <ul style="list-style-type: none">• Battery is fully charged (100% - 75% charge remains).• 75% - 50% charge remains.• 50% - 25% charge remains.• 25% - 10% charge remains.• 10% - no charge remains. When the battery capacity is lower than 10%, the battery icon blinks and an error tone sounds once every minute. |

4-2 LCD display menu

The Home menu consists of five items, which are described in details in the following chapters. Table 4-2 depicts the hierarchy chart of the LCD display menu.

Table 4-2 LCD display menu

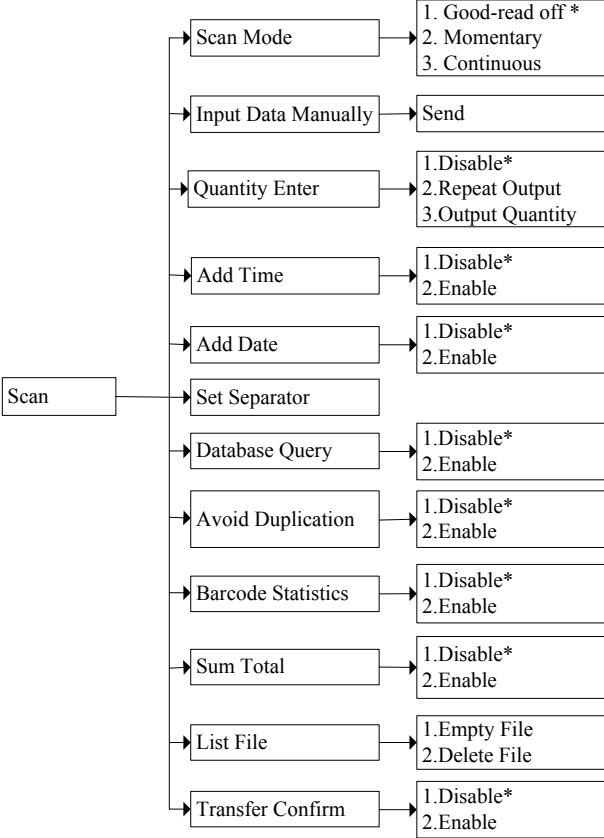
| Menu | Hierarchy chart |
|-----------------------------------------------------------------------------------|----------------------------------------------------------------------------------------------------------------------------------------------------------------------------------------------------------------------------------------------------------------------------------------------------------------------------------------------------------------------------------------------------------------------------------------------------------------------------------------------------------------------------------------------------------------------------------------------------------------------------------------------------------------------------------------------------------------------------------------------------------------------------------------------------------------------------------------------------------------------------------------------------------------------------------------------------------------------------------------------------------------------------------------------------------------------------------------------------------------------------------------------------------------------------------------------------------------------------------------------------------------------------------|
|  |  <pre> graph LR Scan[Scan] --> SM[Scan Mode] SM --> SM1[1. Good-read off *] SM --> SM2[2. Momentary] SM --> SM3[3. Continuous] Scan --> IDMI[Input Data Manually] IDMI --> IDMI1[Send] Scan --> QE[Quantity Enter] QE --> QE1[1.Disable*] QE --> QE2[2.Repeat Output] QE --> QE3[3.Output Quantity] Scan --> AT[Add Time] AT --> AT1[1.Disable*] AT --> AT2[2.Enable] Scan --> AD[Add Date] AD --> AD1[1.Disable*] AD --> AD2[2.Enable] Scan --> SS[Set Separator] Scan --> DQ[Database Query] DQ --> DQ1[1.Disable*] DQ --> DQ2[2.Enable] Scan --> ADU[Avoid Duplication] ADU --> ADU1[1.Disable*] ADU --> ADU2[2.Enable] Scan --> BS[Barcode Statistics] BS --> BS1[1.Disable*] BS --> BS2[2.Enable] Scan --> ST[Sum Total] ST --> ST1[1.Disable*] ST --> ST2[2.Enable] Scan --> LF[List File] LF --> LF1[1.Empty File] LF --> LF2[2.Delete File] Scan --> TC[Transfer Confirm] TC --> TC1[1.Disable*] TC --> TC2[2.Enable] </pre> |

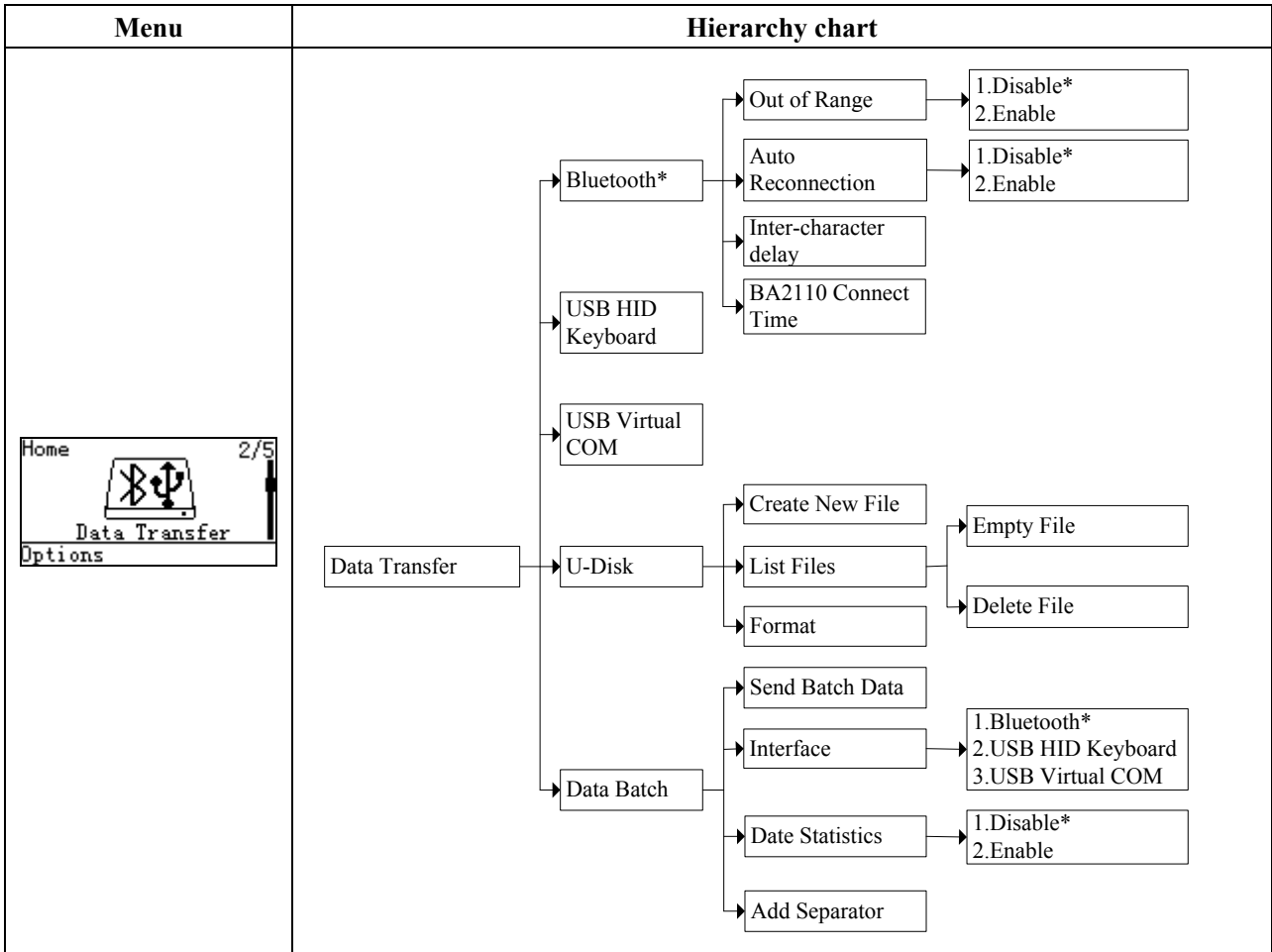

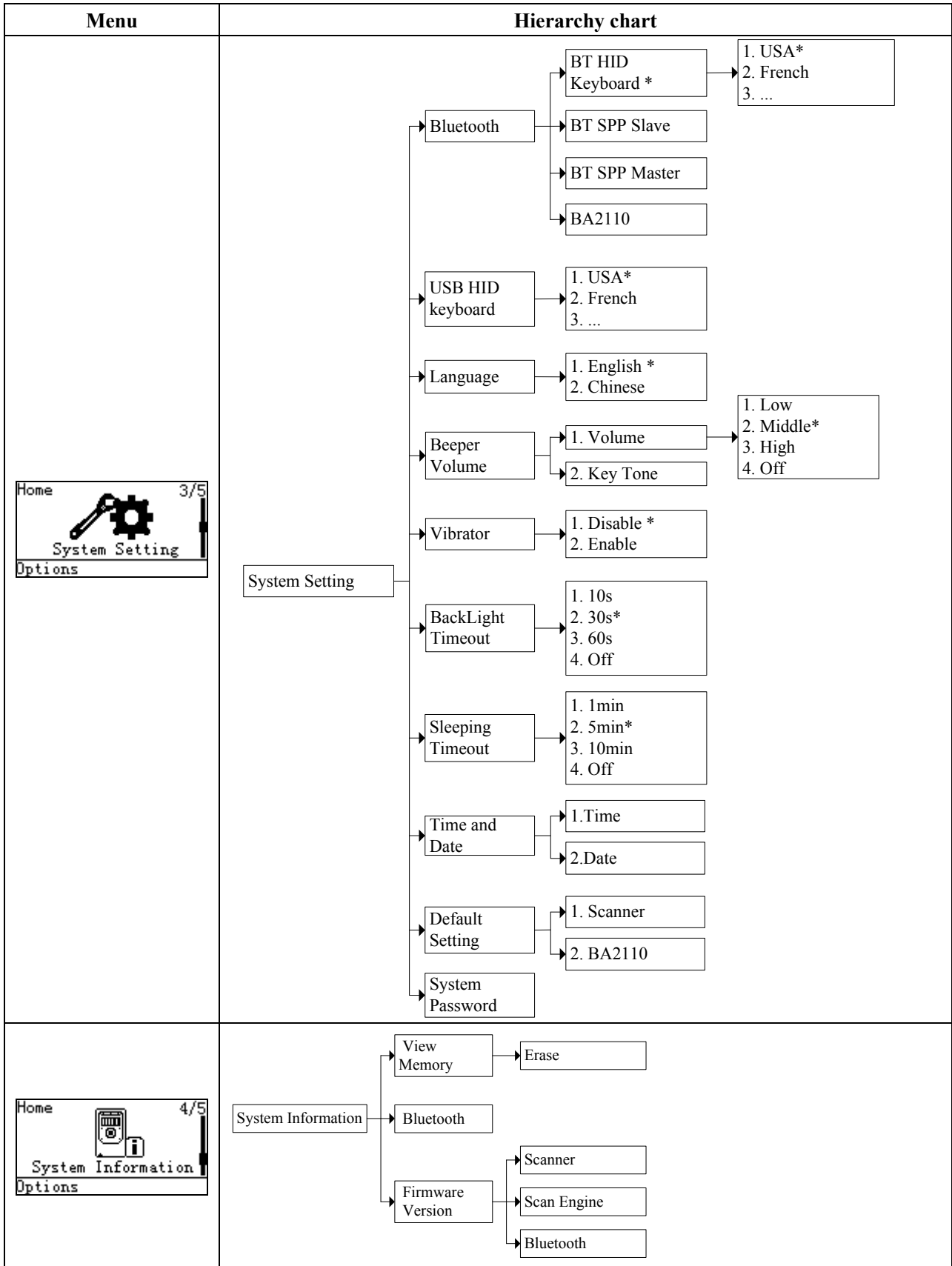

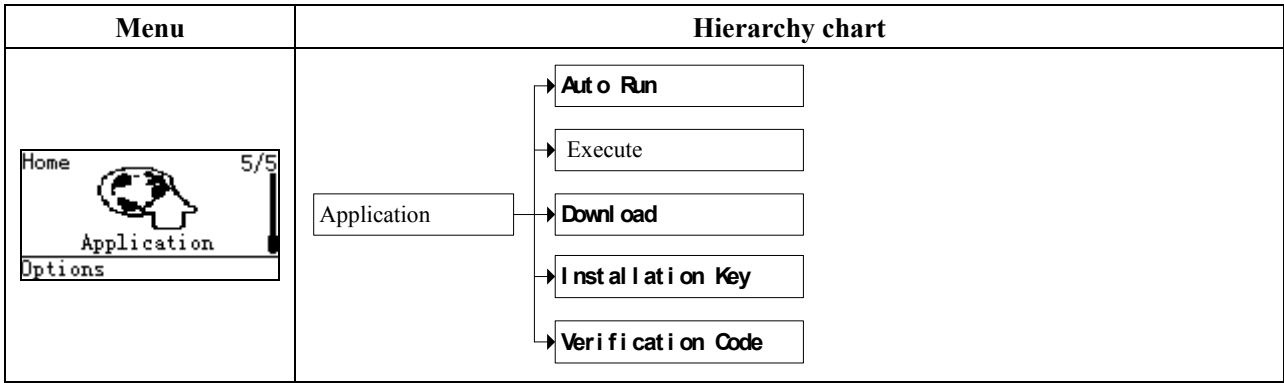

Note: Items that are labeled ‘*’ are default selections.

5 Operations of the scanner

Note:

1. Please establish a Bluetooth network and hold the scanner in the range of the network before the first time of scanning barcodes (See chapters of Configure Bluetooth HID keyboard profile communication, Configure Bluetooth SPP slave profile communication, and Configure Bluetooth SPP master profile communication).
2. The scanner can perform a barcode scan operation even though no Bluetooth network is available. However, the scanner may react in a way that differs from what is described here if no Bluetooth network is working.

5-1 Scan

Steps:

Step 1: When the scanner is powered on, the LCD screen is displayed as below.



Step 2: Hold the scanner close to the barcode and press the Scan Key .

Step 3: The scanner port emits a laser to scan the barcode. The decode success indicator lights green when the scan is successful. The window will show as below.

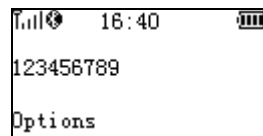

5-1-1 Scan Mode

Good-read off - The Scan key must be pressed once to activate scanning. The light source of scanner stops scanning when there is a successful reading or no code is decoded after the Stand-by duration elapsed.

Momentary - The Scan key acts as a switch. Press the key to activate scanning and release the key to stop scanning. The light source of scanner stops scanning when there is a successful reading or no code is decoded after the Stand-by duration elapsed.

Continuous - The scanner always keeps scanning, and it does not matter when the Scan key is released or duration is elapsed.

5-1-2 Input Data Manually

Using the virtual keypad, user can input a barcode manually, and then send the barcode to the host or store in the scanner.

Make sure a communication link (Bluetooth network or USB cable) is working.

5-1-3 Quantity Enter

User can disable the Quantity Enter and select Repeat Output mode or Output Quantity mode. When Quantity Enter is enabled, user can set the number (0 to 9999) of barcode transmissions. For example, a barcode “123456789” is read. When user select Repeat Output mode, Five “123456789” will be received by the host, given that the quantity is 5. When user selects Output Quantity mode, “123456789, 5” will be received by the host, given that the quantity is 5. The quantity decides how many identify barcodes a host receives upon a single successful read.

Separator Setting- When user selects Output Quantity mode, the barcode and quantity will be separated, the default separator is comma <,>. Separator Setting is Quantity enter-Output **Quantity-Options**. By using the virtual keypad, user can input character manually. The length of the separator string can be at most 10 characters.

The following steps demonstrate the procedure to set a quantity.

Step 1: Enable Quantity Enter, press the Scan Key to read a barcode.

Example display:

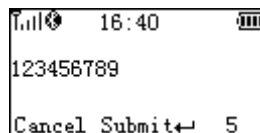

Step 2: Press Right Soft Key to the window below.

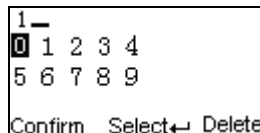

Step 3: Use Navigation Keys to move the cursor, Scan/Select Key to select number(s), Right Soft Key to delete selected number(s). And then press Left Soft Key to continue.

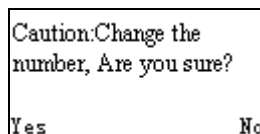

Step 4: Finally press Left Soft Key to complete.

5-1-4 Add Time

The time information can be added as an appendix to a barcode by enabling the Add Time.

For example:

When Add Time is enabled, a barcode “123456789” is read in 12:00:00, “ 123456789,12:00:00” will be received by the host.

When Add Time and Add Date is enabled, a barcode “123456789” is read in 12:00:00 at 25.05.2012, “ 123456789,12:00:00, 25.05.2012” will be received by the host.

5-1-5 Add Date

The data information can be added as an appendix to a barcode by enabling the Add Date.

For example:

When Add Date is enabled, a barcode “123456789” is read in 25.05.2012, “123456789, 25.05.2012” will be received by the host.

When Add Time and Add Date is enabled, a barcode “123456789” is read in 12:00:00 at 25.05.2012, “123456789,12:00:00, 25.05.2012” will be received by the host.

5-1-6 Set Separator

The barcode and Time/Data/quantity will be separated by separator, the default separator is comma <,>. By using the virtual keypad, user can input character manually. The length of the separator string can be at most 10 characters.

Example1: A barcode “123456789” is read in 12:00:00 at 25.05.2012. When user selects Output Quantity mode, “123456789, 5” will be received by the host, given that the quantity is 5.

123456789,5,12:00:00,25.05.2012

Example2: When user enables the Data Statistics, the barcode and quantity will be separated, the eighth barcode is “123456789” in the example below.

123456789,8

5-1-7 Database Query

Database query includes: After successfully scanning the barcode, the barcode information would be displayed on the LCD screen. The database query function demands the use of MS3 DB database supporting software tool to generate database files: *.IDX and *.DAT. By applying the database query functionality, the user can rapidly and accurately locate the barcode information.

When user scan the barcode, the scanner would perform a database searching upon the database files stored in the flash disk and display the barcode information if matching is found when the database query function is enabled. User would require scrolling to left or right for more information displayed on the LCD screen. If no matching is found then “No Record” is displayed on the LCD screen.

Example:

User barcode information as follows:

| | A | B | C | D |
|---|----------|------------|----------|---------------------|
| 1 | Barcode | Trade Name | Price | Place of Production |
| 2 | 12345670 | Computer | ¥3000.00 | Shenzhen |

When user scan the barcode “12345670”, The scanner would display “Computer, ¥3000.00, Shenzhen” on the LCD screen.

Note: The default database files are named SYS_DB.IDX and SYS_DB.DAT. In order to utilize the database functionality user should NOT change these file names and these two files are properly stored

to the flash disk.

5-1-8 Avoid Duplication

When user scans the barcode, the scanner retrieves the database for a match in the meantime. If the barcode does not exist in the database, the barcode will be recorded into the database file, sent out or stored in USB Disk. Neither transmission nor store operation will be performed if a barcode already exists in the database. Furthermore, the “Barcode already exists” message is displayed on the LCD screen.

User can clear the previous barcode record by entering the same barcode avoidance setting menu page and pressing the left soft key (**clear**).

5-1-9 Barcode Statistics

The scanner will automatically count and display the number of the current barcode which have been sent or stored successfully when Barcode Statistics function is enabled.

User can clear the previous barcode record by entering the barcode statistic function setting menu page and pressing the left soft key (**clear**).

5-1-10 Sum Total

The scanner will automatically count and display the number of the whole barcodes which have been sent or stored successfully when Barcode Statistics function is enabled.

User can clear the previous barcode record by entering the barcode statistic function setting menu page and pressing the left soft key (**clear**).

5-1-11 List Files

This menu can be selected to list all files in the root directory. The file selected to be the target file is labeled ✓. The operations described below are imposed to the cursor-on file, which is not necessary to be the target file.

Example:

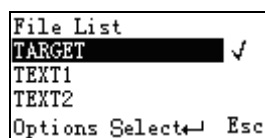

```
File List
TARGET ✓
TEXT1
TEXT2
Options Select ← Esc
```

Options Menu

Note: Press Left Soft Key to popup this menu.

**Caution:**

Empty and Delete operations are not undoable. It is strongly recommended to back up the data before empty or delete operation.

Empty/Delete Files

If the U-disk is almost full, occupied room can be released by emptying/deleting some files.

A target file is protected by system and prevented from being deleting. In this case, the file that is wanted to be deleted should be deselected and then deleted.

5-1-12 Transfer Confirm

User can select to enable/disable the transfer confirm. When the scan is successful, The scanner would point out that whether confirm to transfer this barcode. User can press left soft key to cancel transfer or press right soft key to confirm transfer barcode data.

5-2 Data Transfer

5-2-1 Bluetooth

See **System Setting - Bluetooth** for instructions to establish a Bluetooth network. Three options are listed below.

Out of range batch- The scanner starts storing barcode data when it loses its connection to a remote host (for example, when a user holding the scanner walks out of range). Data transmission is triggered by reestablishing the connection with the host (for example, when a user holding the scanner walks back into range).

Auto reconnection- When scanner's Bluetooth is power on, it will try to establish the wireless connection with the host which it last connected, if Auto Reconnection is enabled.

Inter-char delay- Inter-character delay is abbreviated to Inter-char delay. This delay is inserted after each data character transmitted when configure Bluetooth to HID keyboard profile. Some Bluetooth communication needs large delay to avoid data missing. This default delay is set to 8 milliseconds.

BA2110 Connect Time- This is a standby time for the user to plug the BA2110 into PC after scanned the barcode on the back of BA2110. The default standby time is set to 10 seconds. (For more detail, please refer to "[5-3-6 Configure the profile of BA2110](#)").

5-2-2 USB HID keyboard

When the scanner is USB connected to a PC, it will be identified as a USB HID keyboard and behaves as a USB wired scanner.

5-2-3 USB Virtual COM

When the scanner is USB connected to a PC, it will be identified as a USB Virtual COM and acts as a RS-232 wired scanner.

5-2-4 U Disk

Barcode data is always stored in a text file (TXT file), that is, the scanner functions as a barcode data collector. The scanner will be identified as a USB removable driver when it is USB connected to a PC.

The scanner decides target file to store barcodes according to following rules:

- ✚ If a file is selected by the user, the selected file will be the target file.
- ✚ If there is no file in the U-Disk, a file will be created and named "TARGET.txt" by the scanner when it is powered on or restart. In this case, TARGET.txt will be the target file.
- ✚ The file selected to be the target file is labeled √.

List Files

This menu can be selected to list all files in the root directory. The file selected to be the target file is labeled √. The operations described below are imposed to the cursor-on file, which is not necessary to be the target file.

Example:

```
File List
TARGET ✓
TEXT1
TEXT2
Options Select ← Esc
```

Options Menu

Note: Press Left Soft Key to popup this menu.



Caution:

Empty and Delete operations are not undoable. It is strongly recommended to back up the data before empty or delete operation.

Empty/Delete Files

If the U-disk is almost full, occupied room can be released by emptying/deleting some files.

A target file is protected by system and prevented from being deleting. In this case, the file that is wanted to be deleted should be deselected and then deleted.

Format

Note 1: The format function is a quick way to empty a whole U Disk.

Note 2: Please format the U Disk once before the first time of use.



Caution:

1. Format operation will erase all data on the disk.
2. Format operation is not undoable. It is strongly recommended to back up the data before format operation.

5-2-5 Data Batch

The scanner starts storing barcode data in Date Batch mode. The collected barcode data can then be sent to a host via Bluetooth/USB. Three options are listed below.

Send Batch Data- Data transmission is triggered by this menu command. Before undertaking this operation, make sure a communication link (Bluetooth network or USB cable) is working.

Interfaces- There are three types of communication interfaces Bluetooth, USB HID keyboard and USB virtual COM. A Bluetooth link is needed in the first case (See System Setting→Bluetooth).

Data statistics- User can select to enable/disable the Data Statistics. When it is enabled, the number of a barcode would be added to the end of the barcode. The eighth barcode is “123456789” in the example below.

Example:

```
123456789 , 8
```

Auto Clear-The scanner will clear the stored barcode after finishing sending.

5-3 System Setting

5-3-1 Bluetooth

I Bluetooth functionalities

The scanner can be configured to send data to a PC/Notebook/PDA/other instrument which has an integrated Bluetooth module or is connected with an external Bluetooth USB adapter. A diagram of Bluetooth functionalities and a table of various Bluetooth profiles are shown below, respectively:



Figure 5-1. Diagram of Bluetooth functionalities

Table 5-1 Various Bluetooth profiles

| | |
|---------------------|-------------------------------------------------------------------------------------------------------------------------------------------------------------------------------------------|
| HID Keyboard | The scanner connects to the PC/host via Bluetooth and behaves like a keyboard. The scanner accepts incoming connection requested from a remote device and is the slave. |
| SPP slave | The scanner connects to the PC/host via Bluetooth and behaves like there is a serial connection. The scanner accepts incoming connection requested from a remote device and is the Slave. |
| SPP master | The scanner connects to the PC/host via Bluetooth and behaves like there is a serial connection. The scanner initiates the connection to the remote device and is the Master. |

A master SPP mainly differs from a slave one in the process of connection and they are identical in the process of use in terms of function.

Bluetooth-enabled smart phones and PDAs can host the scanner in general. However, ordinary mobile phones with Bluetooth function can not be a host of the scanner because in most cases neither HID nor SPP profile is supported by them.

II Configure Bluetooth HID keyboard profile communication

Note: Make sure the Bluetooth module of the scanner is powered on (blue LED is on) and the selected profile is System Setting→Bluetooth→BT HID Keyboard.

Step1. Plug a Bluetooth USB adapter into the USB port of the computer.

Step2. Double-click the Bluetooth icon at the right bottom corner on Windows OS ().

Alternatively, you may go to Control Panel->Bluetooth Device.

Step3. Click **Add** to search devices nearby.

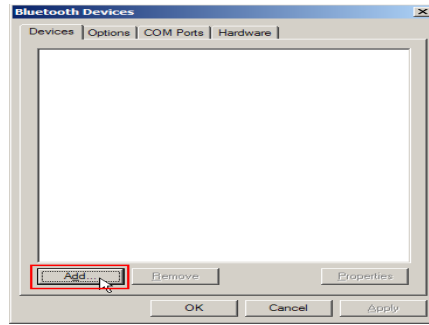

Step4. Click to select “My device is set up and ready to be found” and click **Next**.



Step5. It takes a few seconds for the Wizard to search devices.

The scanner will appear with its serial number as the device name. If the target scanner is seen on the list, click and select the target scanner. Click **Next**. If the target scanner does not appear on the list, click [Search Again] to refresh the list.

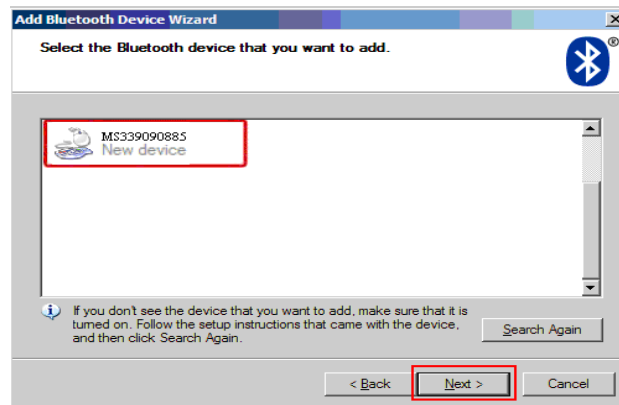

Step6. Click and select “Let me choose my own passkey”. Enter a passkey for authentication and click **Next**.

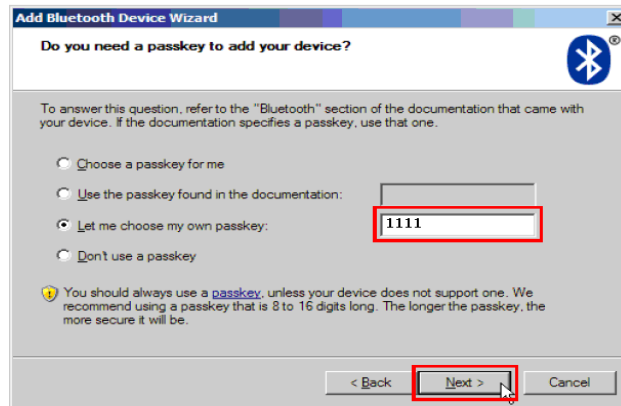

Step7. The scanner promotes the user to accept the connection request. Press Left Soft Key to accept.

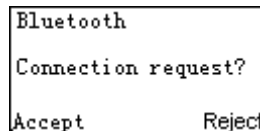

Step8. Enter a passkey which is exactly the same as that entered from the PC. Use Navigation Key to move the cursor, Scan/Select Key to select number(s), Right Software Key to delete selected number. Finally press Left Software Key to continue.

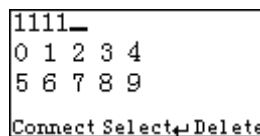

Step9. Wait for a few seconds for Windows to exchange passkeys.

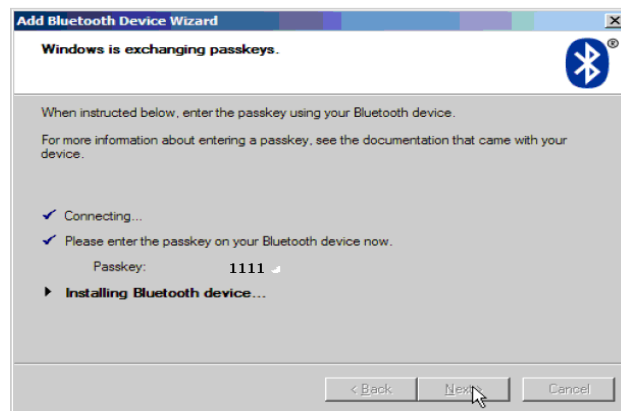

Step10. Click Finish

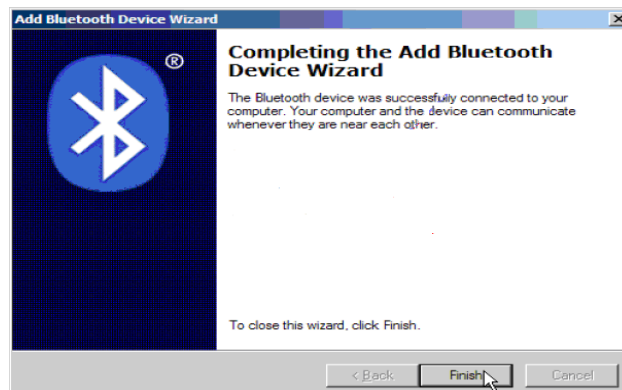

Step11. Now the target scanner will be listed as shown below.

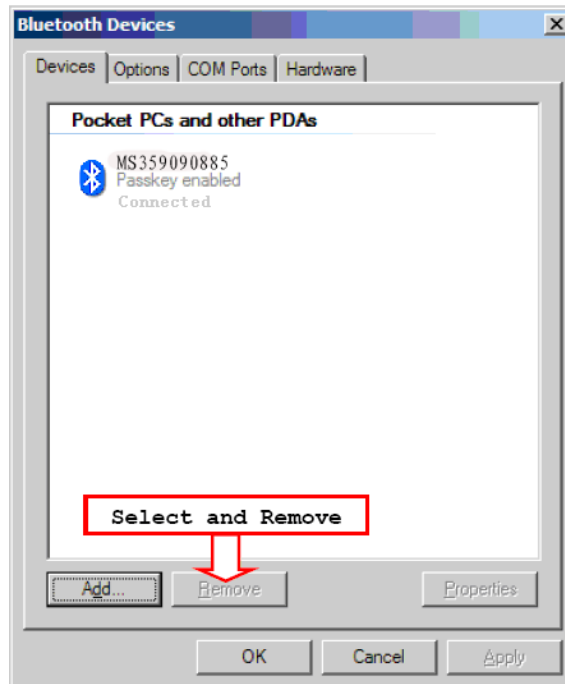

Step12. Run the desired application, such as a Notepad and scan barcodes to check data transmission.

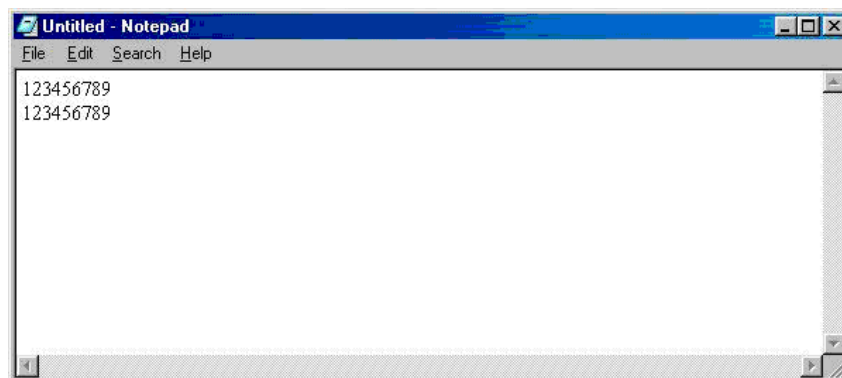

III Configure Bluetooth SPP slave profile communication

Note: Make sure the Bluetooth module of the scanner is powered on (blue LED is on) and the selected profile is System Setting→Bluetooth→BT SPP Slave.

Step1-9: The same as Configure Bluetooth HID keyboard step 1~9.

Step10. Click [Finish]

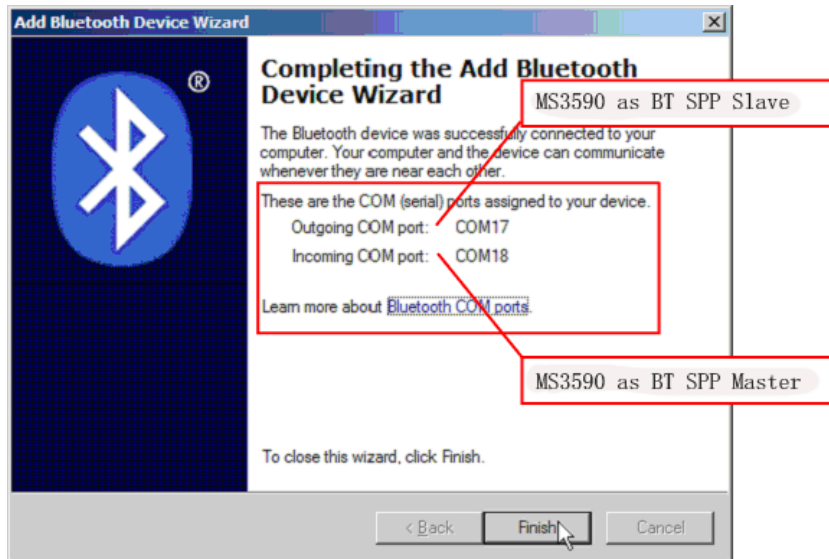

Step11. Now the target scanner will be listed as shown below.

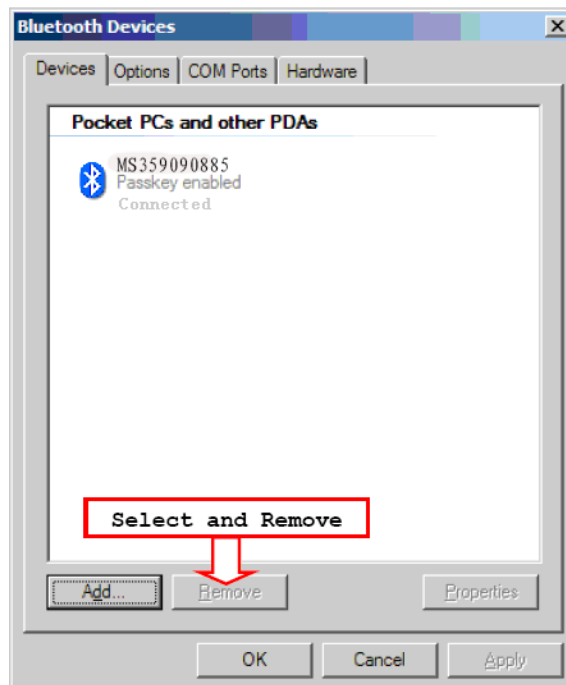

Step12. Run a Serial Port Tool, e.g. HyperTerminal on your computer. This step guarantees the scanner to complete establishing Bluetooth communication. And then scan a barcode to confirm the success of data transmission.

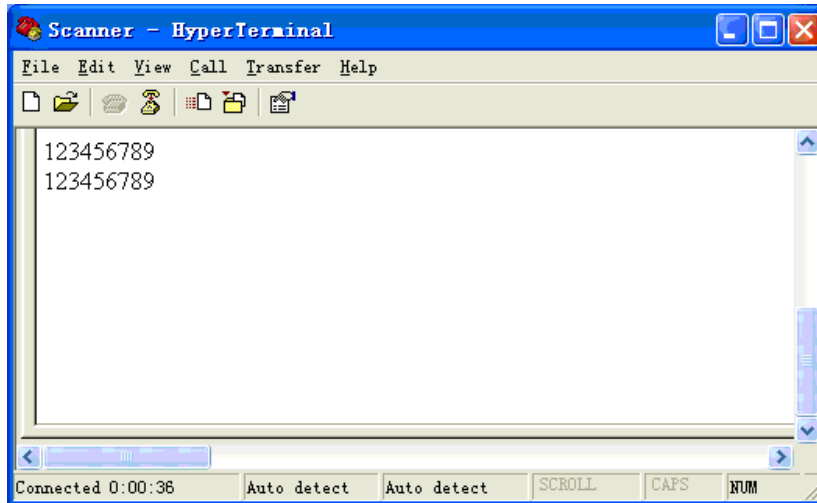

IV Configure Bluetooth SPP master profile communication

Note: Make sure the Bluetooth module of the scanner is powered on (blue LED is on) and the selected profile is System Setting→Bluetooth→BT SPP Master.

Step1. Press Left Soft Key to the window below. If the scanner has no connection record, it will show the indication” There is no connection record.”

```
There is no connection
record.
Search Connect← Esc
```

Step2. Press Left Soft Key to the window below for searching.

```
Bluetooth
Searching.....
```

Step3. Wait for about 20 seconds and then the devices list will be shown.

```
MD2006
HTC Wildfire
Search Connect← Esc
```

Step4. Use Navigation Key to move the cursor and press Scan/Select Key to connect to the Bluetooth USB adapter.

```
Establishing BlueTooth
communication...
Cancel
```

Step5. The remote device will promote user to accept the connection request, and then user enters the passkey. The default passkey of the Bluetooth module of the scanner is “0000”. So enter “0000”, and click OK.

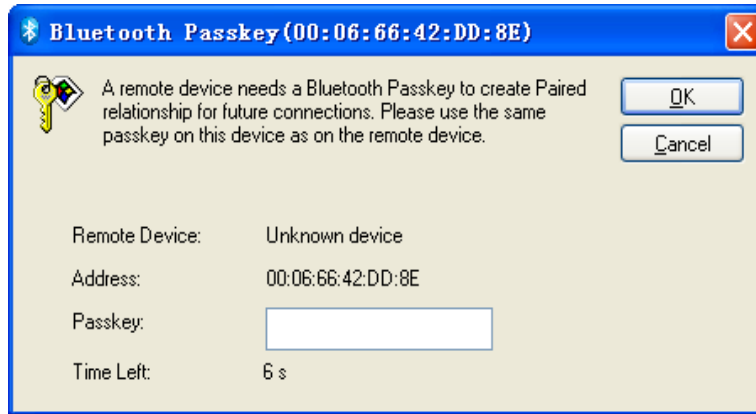

Step6. The Bluetooth device connected to the scanner is labeled ✓.

Step7. If you want to disconnect the Bluetooth device connected successfully before, you can press Scan/Select Key to disconnect it.

V Configure Bluetooth USB adapter BA2110

Notes:

1. BA2110 is provided by the manufacturer to support reliable wireless data transmission and is advised in applications whereas unacknowledged communication is unacceptable.
2. Make sure the Bluetooth module of the scanner is powered on (blue LED is on)
3. By default, the profile of the BA2110 is “USB HID keyboard”. An alternative option is “USB virtual COM”.

There are two methods to setup the Bluetooth communication.

Method I: scanning special barcode.

There is a barcode on the back of BA2110 as shown below. Scan the barcode. The scanner will beep twice to indicate a successful scan. Please plug the BA2110 into PC within **BA2110 Connect Time**, and then wait for about 5 seconds. The scanner will give 2 long beeps upon a successful connection, or 3 short beeps upon a failed connection.



An example of barcode to indicate a BA2110

Note: For more information of the **BA2110 Connect Time**, please refer to **5-2 Data transfer-Bluetooth-BA2110 Connect Time**.

Method II: operating the scanner on the LCD screen.

Step1. Press Left Soft Key towards the window below. If the scanner has no connection record, it will show the indication of “There is no connection record.”

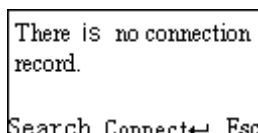

Step2. Press Left Soft Key to the window below for searching.

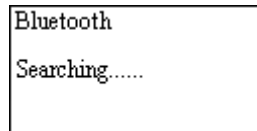

Step3. Wait for about 20 seconds and then BA2110 list will be shown.



Step4. Use Navigation Key to move the cursor and press Scan/Select Key to connect with BA2110.

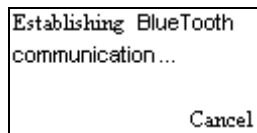

Step5. Wait for about 3 seconds, the scanner will respond with 2 long beeps upon successful connection.

Step6. The BA2110 connected to the scanner is labeled √.

Step7. If you want to disconnect the BA2110 connected successfully before, you can press Scan/Select Key to disconnect it.

VI Configure the profile of BA2110

Note: Before the configuration, make sure the scanner is wireless-connected with the BA2110 successfully.

Step1. Press Left Soft Key to the window below.



Step2. Use Navigation Key to move the cursor and press Scan/Select Key to select items.

5-3-2 USB HID Keyboard

Keyboard layout: The BA2110 supports different national keyboard layouts.

5-3-3 Language

This option is used to select a language for menu display.

5-3-4 Volume of Beeper

Volume-This option is used to control the volume of the beeper.

Keystone-This option is used to turn on/off the Keystone.

5-3-5 Vibrator

This option is used to turn on/off the vibrator indicator of a good read.

5-3-6 Backlight timeout

The scanner will switch off the backlight if time of no operation exceeds **Backlight timeout**.

5-3-7 Sleep timeout

The scanner will enter sleep mode if time of no operation exceeds **Sleeping timeout**. User can set the scanner to sleep mode by press Power/Sleep key (see **Enter/exit sleep mode** and **power on/off Bluetooth**).

5-3-8 Time and Date

This option is used to set the time and the date of the scanner.

5-3-9 Default setting

Default setting includes the scanner and the BA2110.

Table 1 General system setting

| Items | Option |
|-------------------|-------------------------------|
| Language | English* Chinese |
| Beeper volume | Low Middle High* Off |
| Vibrator | Disable Enable* |
| Backlight timeout | 10s 30s* 60s Off |
| Sleeping timeout | 1min 5min* 10min Off |

The profile of BA2110 is USB HID Keyboard, Keyboard layout is USA keyboard layout, Comm. port speed mode is high speed mode, and Numeric key type is Alphabetic key.

Notice : To set all parameters of the BA2110 to default setting, please make sure the BA2110 and the scanner are connected properly.

5-3-10 System password

Application of system password relates to user application (for more detail please refers to 6 user

customized software development). When this option is enabled, system password is required when switching from user application state back to system state.

If the user download the user customized application software, and enable the boot settings, the system is run directly to the user's application when switched on. When user keep pressing the right soft key during system booting stage, the system password is required before entering the system state. Entering the system state is only allowed after the correct password is provided. Pressing the return key could lead to the user customized application software state.

Notice: The default system password of the scanner is “1234”.

Steps for setting the system password:

Step1. Enter the old (previous set) password for verification. Proceed to create new password stage if correct password is provided, otherwise starts over.

Step2. Enter new password.

Step3. Re-enter the new password for verification.

Step4. If the newly entered passwords are identical then creation of new password is successful.

5-4 System Information

5-4-1 View Memory

User can view the used and remain memory capacity in Batch Mode.

```
Total: 8388608 bytes
Used: 0 bytes
Free: 8388608 bytes
Erase Esc
```

Note: User can press Left Soft Key to erase data to release used memory.



Caution:

1. Erasing operation will delete all data in the memory.
2. Erasing operation is not undoable.

5-4-2 Bluetooth

User can view the name and address of the Bluetooth module.

Example:

```
Bluetooth
Name: MS339072578
Address: 00066642DDB6
Esc
```

5-4-3 Firmware Version

User can view the firmware version of the scanner, scan engine, and Bluetooth module.

6 User customized application software for MS3590

With the support of MS3 SDK, The scanner supports user customized application software development. User customized application software is developed with the support of the scanner system API. For more detail about user customized application software development please refer to the MS3 SDK help files.

User customized application menu in the scanner show as below:

6-1 Auto Run

When this option is enabled the scanner would automatically runs the user customized application software after boots. When user keep pressing the right soft key during system booting stage, the system password is required before entering the system state. Entering the system state is only allowed after the correct password is provided. Pressing the return key could lead to the user customized application software state. For more information on system password settings please refer to 5-4 system setting->system password chapter.

Note: It only works after successfully downloaded the user customized application software.

6-2 Execute

User could execute the user customized application software by entering the “Execute” menu. Please be sure the user customized application software is properly downloaded to the scanner before execution.

Delete-User could delete the user customized application software by selecting the “Execute” menu and pressing the left soft key-“Delete”.

6-3 Download

Enter into this menu to download application by MS3 SDK;

Step1. Power on the scanner, enter into the menu: Application->Download;

Step2. Make sure of connecting the PC and MS3590 well with USB cable;

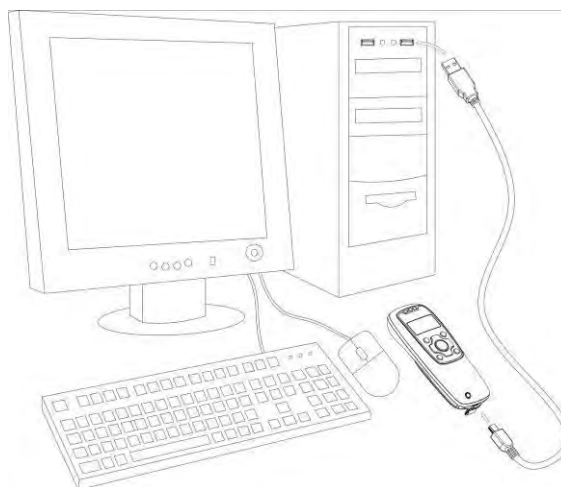

Step3. Clicking on the button  in the toolbar of MS3 SDK to perform download BIN file or ENP file to the scanner;

Step4. After downloaded successfully, the scanner will respond with 2 short beeps.

6-4 Installation key for deciphering encrypted file

The scanner provides setting of user customized application software installation key, which use to decipher a secret BIN file(ENP file).Enter into this menu to download Installation key by MS3 SDK (Click Download-> Download Installation Key).

Notice: Please be sure the installation key is properly downloaded to the scanner before you start to download encrypted file (ENP file) to the scanner.

6-5 Verification code for user customized application software

The scanner provides setting of user customized application software verification code, which are to be verified with user application by invoking the user application verification API. Examples of user application verification are provided in the mobile scanner software development kit user manual.

Enter into this menu to download Installation key by MS3 SDK.

7 Barcode programming instructions

7-1 Single-parameter setting by scanning 1D barcodes

Important notes:

1. During the process of programming, LED is lighting to indicate the programming correctness. LED will go off if any incorrect programming operation performed.
2. After each successful programming, LED will go off and the scanner will beep twice.
3. Throughout the programming barcode menus, **the factory default settings are indicated with asterisks (*)**.

Two programming modes have been provided as bellows:

① Single-scan setting

- Scan the appropriate **Single-scan setting** (e.g. **%0101D00%**) according to the user's demand.

Example: to set **Flow control** to be XON/XOFF.

Steps: Scan the following barcode.



② Multiple-scan setting

- Step 1. Scan the **Option barcode** (e.g. **%0101M%**) according to the user's demand.
- Step 2. To the right of the option barcode, the necessary alphanumeric inputs are listed. Scan two alphanumeric entries from **0** to **9** or **A** to **F**, refer to the chapter of "Configuration alphanumeric entry barcode".
- Step 3. Repeat Step 2, if more user parameters input are required.
- Step 4. Scan the **%END%** barcode, listed on the lower left hand corner of each parameter setting part.

Example: to set **Flow control** to be XON/XOFF.











Steps: Referring to the chapter of "RS-232 interface", scan the following barcodes in order.



7-2 Decode illumination and decode aiming pattern

Decode illumination mode: Enable illumination causes the scanner to turn on the illumination to aid decoding. Disable illumination to turn off illumination for the scanner during decoding. Better quality images could be obtained with illumination support. The effectiveness of the illumination decreases as the distance to the target increases.

Decode aiming pattern: When this option is enabled, the scanner will project the aiming pattern during the code capture.

| Multiple-scan setting | | | Single-scan setting |
|-------------------------------------------------------------------------------------------------------------------------|------------------------|--------------|------------------------------------------------------------------------------------------------------|
| Option barcode | Option | Alpha. Entry | |
| Decode illumination  %9001M% | Always Off | 00 |  %9001D00% |
| | Always On | 01 |  %9001D01% |
| | Flashing | 02 |  %9001D02% |
| | Always-On when reading | 03* |  %9001D03% * |
| Decode aiming pattern  %9002M% | Always Off | 00 |  %9002D00% |
| | Always On | 01 |  %9002D01% |
| | On before reading | 02 |  %9002D02% |
| | On when reading | 03* |  %9002D03% * |
|  %END% | | | |

7-3 DPM, Multiple symbols, Structured append, etc. read setting

2D symbols read: A global setting of 2D symbols readability.

DPM format read: By setting Enable, the scanner can read 2D symbols in DPM (Direct Park Marking) format. Some barcodes in DPM format are shown below.

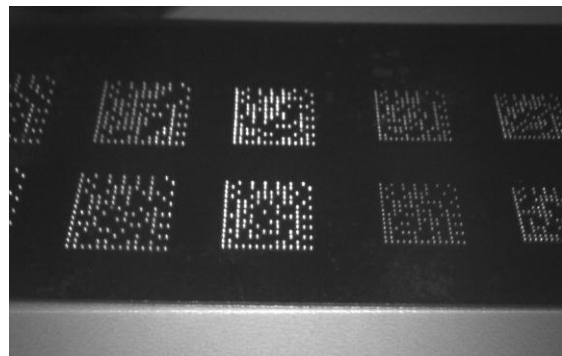

Multiple symbols & structured append symbols read:

1) By setting Enable, the scanner allows to read multiple symbols with a single pull of the scanner's trigger. If the user pulls and holds the trigger, aiming the scanner at a series of symbols, it reads unique symbols once, beeping for each success read. The scanner attempts to find and decode new symbols as long as the trigger is pulled.

2) By setting Enable, the scanner will output data only when all Structured Append symbols have been decoded. The lower part of below figure shows an example of four Structured Append symbols, with the same data as that in the upper symbol.

3) By setting Disable, the scanner will only read the symbol closest to the aiming beam.

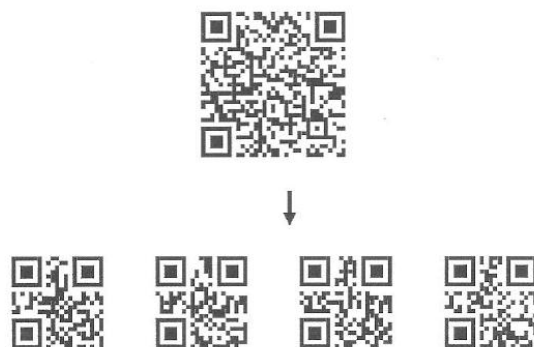







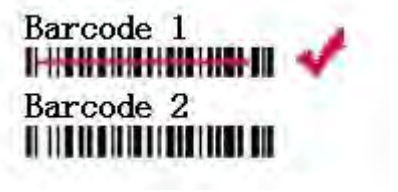











Single symbol (above) and Structured Append series of symbols (below) encoding
"ABCDEFGHIJKLMNOPQRSTUVWXYZ0123456789ABCDEFGHIJKLMNOPQRSTUVWXYZ"

Vertical centering read: By setting Enable, the scanner reads only the barcode centered by the aimer in

vertical direction. However, the scanner will read either one of two barcodes which are positioned horizontally. See example below.



| Multiple-scan setting | | | Single-scan setting |
|---------------------------------------------------------------------------------------------------------------------------------------|-------------------------------------|--------------|------------------------------------------------------------------------------------------------------|
| Option barcode | Option | Alpha. entry | |
| 2D symbols read  %1001M% | Follow respective 2D symbol setting | 00* |  %1001D00% * |
| | All 2D OFF | 01 |  %1001D01% |
| | All 2D ON | 02 |  %1001D02% |
| | Only PDF417 ON | 03 |  %1001D03% |
| | Only QR code ON | 04 |  %1001D04% |
| | Only Data Matrix ON | 05 |  %1001D05% |
| | Only MaxiCode ON | 06 |  %1001D06% |
| | Only Aztec Code ON | 07 |  %1001D07% |
| | Only Han Xin Code ON | 08 |  %1001D08% |
| DPM format read  %1002M% | Disable | 00* |  %1002D00% * |
| | Enable | 01 |  %1002D01% |
| Decode multi-symbols in one read  %1003M% | Multi-symbols | 00 |  %1003D00% |
| | One symbol only | 01* |  %1003D01% * |
| Vertical centering read  %1004M% | Disable | 00* |  %1004D00% * |
| | Enable | 01 |  %1004D01% |



Note: The instruction of calibrating the aimer in vertical centering direction.

1. Scan the barcode on this page. The scanner will give three musical short beeps to indicate entering calibration mode.
2. Press the trigger of the scanner while maintaining the distance of about 15cm between the exit window of the scanner and this paper. After a few seconds, the scanner will give three short beeps to indicate a successful calibration, or a long beep to indicate a failed calibration.
3. If the calibration is failed in step 2, please repeat the steps 1-2. If it is not succeed after a multiple times of calibration, please contact your local dealer or the manufacturer for further instruction.



7-4 Global settings

Scanning mode:

Good-read off-The trigger button must be pressed once to activate scanning. The light source of scanner stops scanning when there is a successful reading or no code is decoded after the **Stand-by duration** elapsed.

Momentary-The trigger button acts as a switch. Press button to activate scanning and release button to stop scanning. The light source of scanner stops scanning when there is a successful reading or no code is decoded after the **Stand-by duration** elapsed.

Continue-The scanner always keeps scanning, and it does not matter when the trigger button is pressed or duration is elapsed.

Same barcode delay time: If a barcode has been scanned and output once successfully, the laser beam must be off or moved away from the barcode beyond delay time to active scanning the same barcode. When this feature is set to be "0xFF", then the delay time is indefinite.

Double confirm: If it is enabled, the scanner will require a several times of same-decoded-data to confirm a valid reading.

Global Max./Min. code length for 1D symbol: These two lengths are defined as the valid range of decoded 1D barcode data length. Make sure that the minimum length setting is no greater than the maximum length setting, or otherwise the labels of the symbol will not be readable. In particular, the same value can be set for both minimum and maximum reading length to force the fixed length barcode decoded.

Notes:

1. Please set the max./min. length for individual barcode in later sections, if special demand is requested.
2. The number of check digits is included in max./min. code length.
3. These two settings have no effect on the symbols with fixed-length, e.g. UPC-A, UPC-E, EAN-13, EAN-8 and China Post.

Global G1-G6 string selection: The scanner offer one or two string group for ALL symbols. By setting one or two digits to indicate which string group you want to apply. You may refer to the chapters of "String setting" and "String position & Number of truncated leading/ending character".

Example: Group 1 → set 01 or 10. Group 2 and 4 → set 24 or 42.

All valid settings include 00, 01, 02, 03, 04, 05, 06, 10, 11, 12, 13, 14, 15, 16, 20, 21, 22, 23, 24, 25, 26, 30, 31, 32, 33, 34, 35, 36, 40, 41, 42, 43, 44, 45, 46, 50, 51, 52, 53, 54, 55, 56, 60, 61, 62, 63, 64, 65 and 66.

Element amendment: If it is enabled, the scanner can read the barcode comprised with bars and spaces in different scale.

Character output restraint:

Printable character only- If this option is selected, the scanner will output the printable characters only, i.e. in ASCII from 20H to 7EH.

Alphanumeric character only- If this option is selected, the scanner will output the alphanumeric characters only, i.e. "A"- "Z", "a"- "z", "0"- "9".

Decoder optimization: If it is enabled, the scanner will optimize the decoder with error correction. This function is not effective for all types of barcodes.

Data output delay in continue-scan mode: If it is enabled, in the continue-scan mode, the scanner can store the data while continue-scanning. The scanner will output the data after the predefined delay elapsed. The maximum storage of data is 1000 characters. If this parameter is set to be "00", the scanner will not store data. And if the parameter is set to be "FF", the scanner will output data after stopping scanning.













Character encoding system: A character encoding system consists of a code that pairs each character from a given repertoire. Common examples include Morse code, the Baudot code, the ASCII and Unicode. If the data received does not display with the proper characters, it may be because the barcode being scanned was created using a character encoding system that is different from the one the host program is expecting. Try alternate options to find the proper one.

Decode-data transfer type in USB HID mode:

Serial- In case of the cable type is set as USB HID mode, while the scanner is doing decode-data transfer to host, other operations are NOT permitted.

Parallel- In case of the cable type is set as USB HID mode, while the scanner is doing decode-data transfer to host, other operations are permitted.

| Multiple-scan setting | | | Single-scan setting |
|-----------------------------------------------------------------------------------------------------------------------------------------|-----------------------------|---------------------|------------------------------------------------------------------------------------------------------|
| Option barcode | Option | Alpha. entry | |
| Scanning mode  %0401M% | Good-read off | 00 |  %0401D00% |
| | Momentary | 01* |  %0401D01% * |
| | Continue | 03 |  %0401D03% |
| Standby duration  %0402M% | 01-99 (second) | 01-99 | |
| | | 04* |  %0402D04% * |
| Same barcode delay time  %0403M% | 00-FF ₁₆ (50ms) | 00-FF ₁₆ | |
| | | 08* |  %0403H08% * |
| Double confirm  %0404M% | 00-09 (00: no) | 00-09 | |
| | | 00* |  %0404D00% * |
| Global max. code length for 1D symbol  %0405M% | 04-99 | 04-99 | |
| | | 99* |  %0405D99% * |
| Global min. code length for 1D symbol  %0406M% | 01-99 | 01-99 | |
| | | 04* |  %0406D04% * |
| Global G1-G6 string selection  %0407M% | 00-66 | 00-66 | |
| | | 00* |  %0407D00% * |
| Element amendment  %0408M% | Disable | 00 |  %0408D00% |
| | Enable | 01* |  %0408D01% * |
| Character output restraint  %0409M% | None | 00* |  %0409D00% * |
| | Printable character only | 01 |  %0409D01% |
| | Alphanumeric character only | 02 |  %0409D02% |
| Decoder optimization | Disable | 00 |  %0410D00% |

| Multiple-scan setting | | | Single-scan setting |
|----------------------------------------------------------------------------------------------------------------------------------------------|---------------|---------------------|----------------------------------------------------------------------------------------------------|
| Option barcode | Option | Alpha. entry | |
|  %0410M% | Enable | 01* |  %0410D01% * |
| Data output delay in continue-scan mode  %0411M% | 00-99 (100ms) | 00-FF ₁₆ | |
| | FF (Never) | 00* |  %0411H00% * |
| Character encoding system  %0413M% | ASCII | 00* |  %0413D00% * |
| | UTF-8 | 01 |  %0413D01% |
| | Windows-1251 | 02 |  %0413D02% |
| Decode-data transfer type in USB HID mode  %0414M% | Serial | 00 |  %0414D00% |
| | Parallel | 01* |  %0414D01% |
|  %END% | | | |

7-5 UPC-A

Read:

Format

| | | |
|------------------|-------------------------|-------------|
| System character | Data digits (10 digits) | Check digit |
|------------------|-------------------------|-------------|

Check digit verification: The check digit is optional.

Check digit trans.: By setting Enable, check digit will be transmitted.

Code ID setting: Code ID is a one-or-two-character string used to represent the symbol upon a succeeding reading. If you want application to transmit Code ID, you must set **Code ID transmission** to be enabled. Refer to the chapter of String transmission.

Insertion group selection: Refer to **Global insertion group selection** of the chapter of Hand-held scan & some global settings.

Supplement digits: The Supplement digits barcode is the supplemental 2 or 5 characters.

Format

| | | | |
|------------------|-------------------------|-------------|--------------------------|
| System character | Data digits (10 digits) | Check digit | Supplement digits 2 or 5 |
|------------------|-------------------------|-------------|--------------------------|

Truncation/Expansion:

Truncate leading zeros- The leading "0" digits of UPC-A data characters can be truncated when the feature is enabled.

Expand to EAN-13- It extends to 13-digits with a "0" leading digit when the feature is enabled.

Truncate system character- The system character of UPC-A data can be truncated when the feature is enabled.

Add country code- The country code ("0" for USA) can be added when the feature is enabled.

| Multiple-scan setting | | | Single-scan setting |
|--------------------------------------------------------------------------------------------------------------------------|-----------------------------|---------------------|------------------------------------------------------------------------------------------------------|
| Option barcode | Option | Alpha. entry | |
| Read  %1101M% | Disable | 00 |  %1101D00% |
| | Enable | 01* |  %1101D01% * |
| Check digit verification  %1102M% | Disable | 00 |  %1102D00% |
| | Enable | 01* |  %1102D01% * |
| Check digit trans.  %1103M% | Disable | 00 |  %1103D00% |
| | Enable | 01* |  %1103D01% * |
| Code ID setting  %1104M% | 00-FF ₁₆ (ASCII) | 00-FF ₁₆ | |
| | | <A>* |  %1104H41% * |
| Insert group selection  %1105M% | 00-66 | 00-66 | |
| | | 00* |  %1105D00% |
| Supplement digits  %1106M% | None | 00* |  %1106D00% * |
| | 2 digits | 01 |  %1106D01% |
| | 5 digits | 02 |  %1106D02% |
| | 2 or 5 digits | 03 |  %1106D03% |
| Truncation/Expansion  %1107M% | None | 00* |  %1107D00% * |
| | Truncate leading zeros | 01 |  %1107D01% |
| | Expand to EAN-13 | 02 |  %1107D02% |
| | Truncate system character | 03 |  %1107D03% |
| | Add country code | 04 |  %1107D04% |



7-6 UPC-E

Read:

Format

| | | |
|----------------------|------------------------|--------------|
| System character "0" | Data digits (6 digits) | Check digits |
|----------------------|------------------------|--------------|

Check digit verification: The check digit is optional and made as the sum of the numerical value of the data digits.

Check digit trans.: By setting Enable, check digit will be transmitted.

Code ID setting: Refer to

| |
|-----------------|
| Code ID setting |
|-----------------|

 of "7-5 UPC-A".

Insertion group selection: Refer to

| |
|---------------------------|
| Insertion group selection |
|---------------------------|

 of "7-5 UPC-A".

Supplement digits:

Format

| | | | |
|----------------------|------------------------|-------------|--------------------------|
| System character "0" | Data digits (6 digits) | Check digit | Supplement digits 2 or 5 |
|----------------------|------------------------|-------------|--------------------------|

Truncation/Expansion:

Truncate leading zeros- Refer to

| |
|----------------------|
| Truncation/Expansion |
|----------------------|

 of "7-5 UPC-A".

Expand to EAN-13- It extends to 13-digits with "0" digits when the feature is set to be enabled.

Example: Barcode "0123654",

Output: "0012360000057".

Expand to UPC-A- It extends to 12-digits when the feature is set to be enabled.

Truncate system character- The system character "0" of UPC-E data can be truncated when the feature is enabled.

| Multiple-scan setting | | | Single-scan setting |
|--------------------------------------------------------------------------------------------------------------------------|-----------------------------|---------------------|---------------------------------------------------------------------------------------------------|
| Option barcode | Option | Alpha. entry | |
| Read  %1201M% | Disable | 00 |  %1201D00% |
| | Enable | 01* |  %1201D01% * |
| Check digit verification  %1202M% | Disable | 00 |  %1202D00% |
| | Enable | 01* |  %1202D01% * |
| Check digit trans.  %1203M% | Disable | 00 |  %1203D00% |
| | Enable | 01* |  %1203D01% * |
| Code ID setting  %1204M% | 00-FF ₁₆ (ASCII) | 00-FF ₁₆ | |
| | | <D>* |  %1204H44% * |
| Insert group selection  %1205M% | 00-66 | 00-66 | |
| | | 00* |  %1205D00% * |
| Supplement digits  %1206M% | None | 00* |  %1206D00% * |
| | 2 digits | 01 |  %1206D01% |
| | 5 digits | 02 |  %1206D02% |
| | 2 or 5 digits | 03 |  %1206D03% |
| Truncation/Expansion  %1207M% | None | 00* |  %1207D00% * |
| | Truncate leading zeros | 01 |  %1207D01% |
| | Expand to EAN-13 | 02 |  %1207D02% |
| | Expand to UPC-A | 03 |  %1207D03% |
| | Truncate system character | 04 |  %1207D04% |



7-7 UPC-E1

Read:

Format

| | | | |
|--------------|-----|-------------------------|--------------|
| Leading zero | "1" | Following 5 data digits | Check digits |
|--------------|-----|-------------------------|--------------|

Check digit verification: The check digit is optional and made as the sum of the numerical value of the data digits.

Check digit trans.: By setting Enable, check digit will be transmitted.

Code ID setting: Refer to

| |
|-----------------|
| Code ID setting |
|-----------------|

 of "7-5 UPC-A".

Insertion group selection: Refer to

| |
|---------------------------|
| Insertion group selection |
|---------------------------|

 of "7-5 UPC-A".

Supplement digits:

Format

| | | | |
|--------------|------------------------|-------------|--------------------------|
| Leading zero | Data digits (6 digits) | Check digit | Supplement digits 2 or 5 |
|--------------|------------------------|-------------|--------------------------|

Truncation/Expansion:

Truncate leading zeros- Refer to

| |
|----------------------|
| Truncation/Expansion |
|----------------------|

 of "7-5 UPC-A".

Expand to EAN-13- It extends to 13-digits with "0" digits when the feature is set to be enabled.

Expand to UPC-A- It extends to 12-digits when the feature is set to be enabled.

Truncate system character- The system character "1" of UPC-E1 data can be truncated when the feature is enabled.

| Multiple-scan setting | | | Single-scan setting |
|--------------------------------------------------------------------------------------------------------------------------|-----------------------------|---------------------|------------------------------------------------------------------------------------------------------|
| Option barcode | Option | Alpha. entry | |
| Read  %3401M% | Disable | 00 |  %3401D00% |
| | Enable | 01* |  %3401D01% * |
| Check digit verification  %3402M% | Disable | 00 |  %3402D00% |
| | Enable | 01* |  %3402D01% * |
| Check digit trans.  %3403M% | Disable | 00 |  %3403D00% |
| | Enable | 01* |  %3403D01% * |
| Code ID setting  %3404M% | 00-FF ₁₆ (ASCII) | 00-FF ₁₆ | |
| | | <D>* |  %3404H44% * |
| Insert group selection  %3405M% | 00-66 | 00-66 | |
| | | 00* |  %3405D00% * |
| Supplement digits  %3406M% | None | 00* |  %3406D00% * |
| | 2 digits | 01 |  %3406D01% |
| | 5 digits | 02 |  %3406D02% |
| | 2 or 5 digits | 03 |  %3406D03% |
| Truncation/Expansion  %3407M% | None | 00* |  %3407D00% * |
| | Truncate leading zeros | 01 |  %3407D01% |
| | Expand to EAN-13 | 02 |  %3407D02% |
| | Expand to UPC-A | 03 |  %3407D03% |
| | Truncate system character | 04 |  %3407D04% |



7-8 EAN-13 (ISBN/ISSN)

Read:

Format

| | |
|-------------------------|-------------|
| Data digits (12 digits) | Check digit |
|-------------------------|-------------|

Check digit verification: The check digit is optional and made as the sum of the numerical value of the data digits.

Check digit transmission: By setting Enable, check digit will be transmitted.

EAN-13 code ID setting: Refer to

| |
|-----------------|
| Code ID setting |
|-----------------|

 of “7-5 UPC-A”.

Insertion group selection: Refer to

| |
|---------------------------|
| Insertion group selection |
|---------------------------|

 of “7-5 UPC-A”.

Supplement digits:

Format

| | | |
|-------------------------|-------------|--------------------------|
| Data digits (12 digits) | Check digit | Supplement digits 2 or 5 |
|-------------------------|-------------|--------------------------|

ISBN/ISSN: The ISBN (International Standard Book Number, or Bookland EAN) and ISSN (International Standard Serial Number) are two kinds of barcode for books and magazines. The ISBN is 10 digits with leading “978” and the ISSN is 8 digits with leading “977” of the EAN-13 symbol.

Example:











Barcode “9780194315104”, Output: “019431510X”.

Barcode “9771005180004”, Output: “10051805”.

ISBN/ISSN code ID setting: Refer to

| |
|-----------------|
| Code ID setting |
|-----------------|

 of “7-5 UPC-A”.

| Multiple-scan setting | | | Single-scan setting |
|-----------------------------------------------------------------------------------------------------------------------------|---------------------|---------------------|------------------------------------------------------------------------------------------------------|
| Option barcode | Option | Alpha. entry | |
| Read  %1301M% | Disable | 00 |  %1301D00% |
| | Enable | 01* |  %1301D01% * |
| Check digit verification  %1302M% | Disable | 00 |  %1302D00% |
| | Enable | 01* |  %1302D01% * |
| Check digit transmission  %1303M% | Disable | 00 |  %1303D00% |
| | Enable | 01* |  %1303D01% * |
| EAN-13 code ID setting  %1304M% | 00-FF ₁₆ | 00-FF ₁₆ | |
| | (ASCII) | <A>* |  %1304H41% * |
| Insert group selection  %1305M% | 00-66 | 00-66 | |
| | | 00* |  %1305D00% * |
| Supplement digits  %1306M% | None | 00* |  %1306D00% * |
| | 2 digits | 01 |  %1306D01% |
| | 5 digits | 02 |  %1306D02% |
| | 2 or 5 digits | 03 |  %1306D03% |
| ISBN/ISSN conversion  %1307M% | Disable | 00* |  %1307D00% * |
| | Enable | 01 |  %1307D01% |
| ISBN/ISSN code ID setting  %1309M% | 00-FF ₁₆ | 00-FF ₁₆ | |
| | (ASCII) | * |  %1309H42% * |
|  %END% | | | |

7-9 EAN-8

Read:

Format

| | |
|------------------------|-------------|
| Data digits (7 digits) | Check digit |
|------------------------|-------------|

Check digit verification: The check digit is optional and made as the sum of the numerical value of the data digits.

Check digit trans.: By setting Enable, check digit will be transmitted.

Code ID setting: Refer to

| |
|-----------------|
| Code ID setting |
|-----------------|

 of “7-5 UPC-A”.

Insertion group selection: Refer to

| |
|---------------------------|
| Insertion group selection |
|---------------------------|

 of “7-5 UPC-A”.

Supplement digits:





















Format

| | | |
|------------------------|-------------|--------------------------|
| Data digits (7 digits) | Check digit | Supplement Digits 2 or 5 |
|------------------------|-------------|--------------------------|

Truncation/Expansion: Refer to

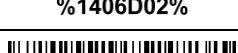
| |
|----------------------|
| Truncation/Expansion |
|----------------------|

 of “7-5 UPC-A”.

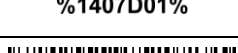
| Multiple-scan setting | | | Single-scan setting |
|--------------------------------------------------------------------------------------------------------------------------|-----------------------------|---------------------|------------------------------------------------------------------------------------------------------|
| Option barcode | Option | Alpha. entry | |
| Read  %1401M% | Disable | 00 |  %1401D00% |
| | Enable | 01* |  %1401D01% * |
| Check digit verification  %1402M% | Disable | 00 |  %1402D00% |
| | Enable | 01* |  %1402D01% * |
| Check digit trans.  %1403M% | Disable | 00 |  %1403D00% |
| | Enable | 01* |  %1403D01% * |
| Code ID setting  %1404M% | 00-FF ₁₆ (ASCII) | 00-FF ₁₆ | |
| | | <C>* |  %1404H42% * |
| Insert group selection  %1405M% | 00-66 | 00-66 | |
| | | 00* |  %1405D00% * |
| Supplement digits  %1406M% | None | 00* |  %1406D00% * |
| | 2 digits | 01 |  %1406D01% |
| | 5 digits | 02 |  %1406D02% |
| | 2 or 5 digits | 03 |  %1406D03% |
| Truncation/Expansion  %1407M% | None | 00* |  %1407D00% * |
| | Truncate leading zero | 01 |  %1407D01% |
| | Expand to EAN-13 | 02 |  %1407D02% |

 %END%

7-10 Code 39 (Code 32, Trioptic Code 39)

Read:

Format

| | | | |
|---|------------------------|------------------------|---|
| ★ | Data digits (variable) | Check digit (optional) | ★ |
|---|------------------------|------------------------|---|

Check digit verification: The check digit is optional and made as the sum module 43 of the numerical value of the data digits.

Check digit transmission: By setting Enable, check digit will be transmitted.

Max./Min. code length: Each symbol has own max./min. code length. If both setting of max./min. code length are "00"s, the setting of global max./min. code length is effective. The length is defined as to the actual barcode data length to be sent. Label with length exceeds these limits will be rejected. Make sure that the minimum length setting is no greater than the maximum length setting, or otherwise all the labels of the symbol will not be readable. In particular, you can see the same value for both minimum and maximum reading length to force the fixed length barcode decoded.

Code ID setting: Refer to

| |
|-----------------|
| Code ID setting |
|-----------------|

 of "[7-5 UPC-A](#)".

Insertion group selection: Refer to

| |
|---------------------------|
| Insertion group selection |
|---------------------------|

 of "[7-5 UPC-A](#)".

Start/End transmission: The start and end characters of Code 39 are "★". You can transmit all data digits including two "★".

"★" as data character: By setting Enable, "★" can be recognized as data character.

Convert Code 39 to Code 32: Code 32 is a variant of Code 39 used by the Italian pharmaceutical industry. Note that Code 39 must be enabled in order for this parameter to function.

Format of Code 32

| | | |
|----------------|------------------------|-------------|
| "A" (optional) | Data digits (8 digits) | Check digit |
|----------------|------------------------|-------------|

Code 32 Prefix "A" transmission: By setting Enable, the prefix character "A" can be added to all Code 32 barcodes.













Trioptic Code 39 read: Trioptic Code 39 is a variant of Code 39 used in the marking of magnetic tapes and computer cartridges. Trioptic Code 39 symbols always contain six characters.

Format

| | | |
|----|------------------------|----|
| \$ | Data digits (6 digits) | \$ |
|----|------------------------|----|

Trioptic Code 39 Start/End transmission: The start and end characters of Trioptic Code 39 are "\$". You can transmit all data digits including two "\$".

| Multiple-scan setting | | | Single-scan setting |
|--------------------------------------------------------------------------------------------------------------------------|--------------------------------|---------------------|---------------------------------------------------------------------------------------------------|
| Option barcode | Option | Alpha. entry | |
| Read  %1501M% | Disable | 00 |  %1501D00% |
| | Enable | 01* |  %1501D01% * |
| Check digit verification  %1502M% | Disable | 00* |  %1502D00% * |
| | Enable | 01 |  %1502D01% |
| Check digit transmission  %1503M% | Disable | 00* |  %1503D00% * |
| | Enable | 01 |  %1503D01% |
| Max. code length  %1504M% | 00-99 | 00-99 | |
| | | 00* |  %1504D00% * |
| Min. code length  %1505M% | 00-99 | 00-99 | |
| | | 01* |  %1505D01% * |
| Code ID setting  %1506M% | 00-FF ₁₆ (ASCII) | 00-FF ₁₆ | |
| | | <M>* |  %1506H4D% * |
| Insert group selection  %1507M% | 00-66 | 00-66 | |
| | | 00* |  %1507D00% * |
| Format  %1508M% | Standard | 00* |  %1508D00% * |
| | Full ASCII | 01 |  %1508D01% |
| Start/End transmission  %1509M% | Disable | 00* |  %1509D00% * |
| | Enable | 01 |  %1509D01% |
| “*” as data character  %1510M% | Disable | 00* |  %1510D00% * |
| | Enable | 01 |  %1510D01% |
| Convert Code 39 to Code | Disable | 00* |  %1511D00% * |

| Multiple-scan setting | | | Single-scan setting |
|--------------------------------------------------------------------------------------------------------------------------------------------|---------|--------------|----------------------------------------------------------------------------------------------------|
| Option barcode | Option | Alpha. entry | |
| 32  %1511M% | Enable | 01 |  %1511D01% |
| Code 32 Prefix "A" transmission  %1512M% | Disable | 00* |  %1512D00% * |
| | Enable | 01 |  %1512D01% |
| Trioptic Code 39 read  %1513M% | Disable | 00* |  %1513D00% * |
| | Enable | 01 |  %1513D01% |
| Trioptic Code 39 Start/End transmission  %1514M% | Disable | 00* |  %1514D00% * |
| | Enable | 01 |  %1514D01% |
|  %END% | | | |

7-11 Interleaved 2 of 5

Read:

Format

| | |
|------------------------|------------------------|
| Data digits (Variable) | Check digit (optional) |
|------------------------|------------------------|

Check digit verification: The check digit is made as the sum module 10 of the numerical values of all data digits. There are two optional check digit algorithms: the specified Uniform Symbol Specification (USS) and the Optical Product Code Council (OPCC).

Check digit transmission: By setting Enable, check digit will be transmitted.

Max./Min. code length: Refer to

| |
|-----------------------|
| Max./Min. code length |
|-----------------------|

 of “*7-10 Code 39*”.

Code ID setting: Refer to

| |
|-----------------|
| Code ID setting |
|-----------------|

 of “*7-5 UPC-A*”.

Insertion group selection: Refer to

| |
|---------------------------|
| Insertion group selection |
|---------------------------|

 of “*7-5 UPC-A*”.

| Multiple-scan setting | | | Single-scan setting |
|--------------------------------------------------------------------------------------------------------------------------|--------------------------------|---------------------|------------------------------------------------------------------------------------------------------|
| Option barcode | Option | Alpha. entry | |
| Read  %1601M% | Disable | 00 |  %1601D00% |
| | Enable | 01* |  %1601D01% * |
| Check digit verification  %1602M% | Disable | 00* |  %1602D00% * |
| | USS | 01 |  %1602D01% |
| | OPCC | 02 |  %1602D02% |
| Check digit transmission  %1603M% | Disable | 00* |  %1603D00% * |
| | Enable | 01 |  %1603D01% |
| Max. code length  %1604M% | 00-99 | 00-99 | |
| | | 00* |  %1604D00% * |
| Min. code length  %1605M% | 00-99 | 00-99 | |
| | | 06* |  %1605D06% * |
| Code ID setting  %1606M% | 00-FF ₁₆ (ASCII) | 00-FF ₁₆ | |
| | | <I>* |  %1606H49% * |
| Insert group selection  %1607M% | 00-66 | 00-66 | |
| | | 00* |  %1607D00% * |
|  %END% | | | |

7-12 Industrial 2 of 5 (Discrete 2 of 5)

Read:









Format

Data digits (variable)

Max./Min. code length: Refer to Max./Min. code length of "7-10 Code 39".

Code ID setting: Refer to Code ID setting of "7-5 UPC-A".

Insertion group selection: Refer to Insertion group selection of "7-5 UPC-A".

| Multiple-scan setting | | | Single-scan setting |
|--------------------------------------------------------------------------------------------------------------------------|--------------------------------|---------------------|------------------------------------------------------------------------------------------------------|
| Option barcode | Option | Alpha. entry | |
| Read  %1701M% | Disable | 00* |  %1701D00% * |
| | Enable | 01 |  %1701D01% |
| Max. code length  %1702M% | 00-99 | 00-99 | |
| | | 00* |  %1702D00% * |
| Min. code length  %1703M% | 00-99 | 00-99 | |
| | | 00* |  %1703D00% * |
| Code ID setting  %1704M% | 00-FF ₁₆ (ASCII) | 00-FF ₁₆ | |
| | | <H>* |  %1704H48% * |
| Insert group selection  %1705M% | 00-66 | 00-66 | |
| | | 00* |  %1705D00% * |
|  %END% | | | |

7-13 Matrix 2 of 5

Read:

Format

| | |
|------------------------|------------------------|
| Data digits (variable) | Check digit (optional) |
|------------------------|------------------------|

Check digit verification: The check digit is made as the sum module 10 of the numerical values of all data digits.

Check digit transmission: By setting Enable, check digit will be transmitted.

Max./Min. code length: Refer to Max./Min. code length of "7-10 Code 39".

Code ID setting: Refer to Code ID setting of "7-5 UPC-A".

Insertion group selection: Refer to Insertion group selection of "7-5 UPC-A".

| Multiple-scan setting | | | Single-scan setting |
|----------------------------------------------------------------------------------------------------------------------------|--------------------------------|---------------------|------------------------------------------------------------------------------------------------------|
| Option barcode | Option | Alpha. entry | |
| Read  %1801M% | Disable | 00 |  %1801D00% |
| | Enable | 01* |  %1801D01% * |
| Check digit verification  %1802M% | Disable | 00* |  %1802D00% * |
| | Enable | 01 |  %1802D01% |
| Check digit transmission  %1803M% | Disable | 00* |  %1803D00% * |
| | Enable | 01 |  %1803D01% |
| Max. code length  %1804M% | 00-99 | 00-99 | |
| | | 00* |  %1804D00% * |
| Min. code length  %1805M% | 00-99 | 00-99 | |
| | | 06* |  %1805D06% * |
| Code ID setting  %1806M% | 00-FF ₁₆ (ASCII) | 00-FF ₁₆ | |
| | | <X>* |  %1806H58% * |
| Insert group selection  %1807M% | 00-66 | 00-66 | |
| | | 00* |  %1807D00% * |
|  %END% | | | |

7-14 Codabar

Read:

Format

| | | | |
|-------|------------------------|------------------------|-----|
| Start | Data digits (variable) | Check digit (optional) | End |
|-------|------------------------|------------------------|-----|

Check digit verification: The check digit is made as the sum module 16 of the numerical values of all data digits.

Check digit transmission: By setting Enable, check digit will be transmitted.

Max./Min. code length: Refer to **Max./Min. code length** of “7-10 Code 39”.















Code ID setting: Refer to **Code ID setting** of “7-5 UPC-A”.

Insertion group selection: Refer to **Insertion group selection** of “7-5 UPC-A”.

Start/End type: Codabar has four pairs of Start/End pattern; you may select one pair to match your application.

Start/End transmission: Refer to **Start/End transmission** of Code 39.

Start/End character equality: By setting Enable, the start and end character of a Codabar barcode must be the same.

| Multiple-scan setting | | | Single-scan setting |
|----------------------------------------------------------------------------------------------------------------------------|--------------------------------|---------------------|------------------------------------------------------------------------------------------------------|
| Option barcode | Option | Alpha. entry | |
| Read  %1901M% | Disable | 00 |  %1901D00% |
| | Enable | 01* |  %1901D01% * |
| Check digit verification  %1902M% | Disable | 00* |  %1902D00% * |
| | Enable | 01 |  %1902D01% |
| Check digit transmission  %1903M% | Disable | 00* |  %1903D00% * |
| | Enable | 01 |  %1903D01% |
| Max. code length  %1904M% | 00-99 | 00-99 | |
| | | 00* |  %1904D00% * |
| Min. code length  %1905M% | 00-99 | 00-99 | |
| | | 00* |  %1905D00% * |
| Code ID setting  %1906M% | 00-FF ₁₆ (ASCII) | 00-FF ₁₆ | |
| | | <N>* |  %1906H4E% * |
| Insert group selection | 00-66 | 00-66 | |

| Multiple-scan setting | | | Single-scan setting |
|------------------------------------------------------------------------------------------------------------------------------|-----------|--------------|----------------------------------------------------------------------------------------------------|
| Option barcode | Option | Alpha. entry | |
|  %1907M% | | 00* |  %1907D00% * |
| Start/End type  %1908M% | ABCD/ABCD | 00* |  %1908D00% * |
| | abcd/abcd | 01 |  %1908D01% |
| | ABCD/TN*E | 02 |  %1908D02% |
| | abcd/tn*e | 03 |  %1908D03% |
| Start/End transmission  %1909M% | Disable | 00* |  %1909D00% * |
| | Enable | 01 |  %1909D01% |
| Start/End character equality  %1910M% | Disable | 00* |  %1910D00% * |
| | Enable | 01 |  %1910D01% |
|  %END% | | | |

7-15 Code 128

Read:

Format

| | |
|------------------------|------------------------|
| Data digits (variable) | Check digit (optional) |
|------------------------|------------------------|

Check digit verification: The check digit is made as the sum module 103 of all data digits.

Check digit transmission: By setting Enable, check digit will be transmitted.

Max./Min. code length: Refer to

| |
|-----------------------|
| Max./Min. code length |
|-----------------------|

 of “*7-10 Code 39*”.

Code ID setting: Refer to

| |
|-----------------|
| Code ID setting |
|-----------------|





















 of “*7-5 UPC-A*”.

Insertion group selection: Refer to

| |
|---------------------------|
| Insertion group selection |
|---------------------------|

 of “*7-5 UPC-A*”.

Truncate leading zeros: The leading “0” digits of Code 128 barcode characters can be truncated when the feature is enabled.

| Multiple-scan setting | | | Single-scan setting |
|--------------------------------------------------------------------------------------------------------------------------|--------------------------------|---------------------|------------------------------------------------------------------------------------------------------|
| Option barcode | Option | Alpha. entry | |
| Read  %2001M% | Disable | 00 |  %2001D00% |
| | Enable | 01* |  %2001D01% * |
| Check digit verification  %2002M% | Disable | 00 |  %2002D00% |
| | Enable | 01* |  %2002D01% * |
| Check digit transmission  %2003M% | Disable | 00* |  %2003D00% * |
| | Reserved | 01 |  %2003D01% |
| Max. code length  %2004M% | 00-99 | 00-99 | |
| | | 00* |  %2004D00% * |
| Min. code length  %2005M% | 00-99 | 00-99 | |
| | | 01* |  %2005D01% * |
| Code ID setting  %2006M% | 00-FF ₁₆ (ASCII) | 00-FF ₁₆ | |
| | | <K>* |  %2006H4B% * |
| Insert group selection  %2007M% | 00-66 | 00-66 | |
| | | 00* |  %2007D00% * |
| Truncate leading zeros  %2008M% | Disable | 00* |  %2008D00% * |
| | All leading "0"s | 01 |  %2008D01% |
| | Only the first "0" | 02 |  %2008D02% |
|  %END% | | | |

7-16 UCC/EAN 128

Read:

Format

| | |
|------------------------|------------------------|
| Data digits (variable) | Check digit (optional) |
|------------------------|------------------------|

Check digit verification: The check digit is made as the sum module 103 of all data digits.

Check digit transmission: By setting Enable, check digit will be transmitted.

Max. /Min. code length: Refer to [Max./Min. code length](#) of “*7-10 Code 39*”.

Code ID setting: Refer to [Code ID setting](#) of “*7-5 UPC-A*”.

Insertion group selection: Refer to [Insertion group selection](#) of “*7-5 UPC-A*”.

Truncate leading zeros: Refer to [Truncate leading zeros](#) of “*7-15 Code 128*”.

| Multiple-scan setting | | | Single-scan setting |
|--------------------------------------------------------------------------------------------------------------------------|--------------------------------|---------------------|------------------------------------------------------------------------------------------------------|
| Option barcode | Option | Alpha. entry | |
| Read  %2501M% | Disable | 00 |  %2501D00% |
| | Enable | 01* |  %2501D01% * |
| Check digit verification  %2502M% | Disable | 00 |  %2502D00% |
| | Enable | 01* |  %2502D01% * |
| Check digit transmission  %2503M% | Disable | 00* |  %2503D00% * |
| | Reserved | 01 |  %2503D01% |
| Max. code length  %2504M% | 00-99 | 00-99 | |
| | | 00* |  %2504D00% * |
| Min. code length  %2505M% | 00-99 | 00-99 | |
| | | 01* |  %2505D01% * |
| Code ID setting  %2506M% | 00-FF ₁₆ (ASCII) | 00-FF ₁₆ | |
| | | <K>* |  %2506H4B% * |
| Insert group selection  %2507M% | 00-66 | 00-66 | |
| | | 00* |  %2507D00% * |
| Truncate leading zeros  %2508M% | Disable | 00* |  %2508D00% * |
| | All leading "0"s | 01 |  %2508D01% |
| | Only the first "0" | 02 |  %2508D02% |
|  %END% | | | |

7-17 ISBT 128

Read:

Format

| | | |
|------------|------------------------|------------------------|
| “=” or “&” | Data digits (variable) | Check digit (optional) |
|------------|------------------------|------------------------|

Check digit verification: The check digit is made as the sum module 103 of all data digits.

Check digit transmission: By setting Enable, check digit will be transmitted.

Max./Min. code length: Refer to Max./Min. code length of “7-10 Code 39”.

Code ID setting: Refer to Code ID setting of “7-5 UPC-A”.

Insertion group selection: Refer to Insertion group selection of “7-5 UPC-A”.

| Multiple-scan setting | | | Single-scan setting |
|----------------------------------------------------------------------------------------------------------------------------|--------------------------------|---------------------|------------------------------------------------------------------------------------------------------|
| Option barcode | Option | Alpha. entry | |
| Read  %3301M% | Disable | 00 |  %3301D00% |
| | Enable | 01* |  %3301D01% * |
| Check digit verification  %3302M% | Disable | 00 |  %3302D00% |
| | Enable | 01* |  %3302D01% * |
| Check digit transmission  %3303M% | Disable | 00* |  %3303D00% * |
| | Reserved | 01 |  %3303D01% |
| Max. code length  %3304M% | 00-99 | 00-99 | |
| | | 00* |  %3304D00% * |
| Min. code length  %3305M% | 00-99 | 00-99 | |
| | | 01* |  %3305D01% * |
| Code ID setting  %3306M% | 00-FF ₁₆ (ASCII) | 00-FF ₁₆ | |
| | | <K>* |  %3306H4B% * |
| Insert group selection  %3307M% | 00-66 | 00-66 | |
| | | 00* |  %3307D00% * |
|  %END% | | | |

7-18 Code 93

Read:

Format

| | |
|------------------------|---------------------------|
| Data digits (variable) | 2 check digits (optional) |
|------------------------|---------------------------|

Check digit verification: The check digit is made as the sum module 47 of the numerical values of all data digits.

Check digit transmission: By setting Enable, check digit will be transmitted.

Max./Min. code length: Refer to

| |
|-----------------------|
| Max./Min. code length |
|-----------------------|

 of "7-10 Code 39".

Code ID setting: Refer to

| |
|-----------------|
| Code ID setting |
|-----------------|

 of "7-5 UPC-A".

Insertion group selection: Refer to

| |
|---------------------------|
| Insertion group selection |
|---------------------------|

 of "7-5 UPC-A".

| Multiple-scan setting | | | Single-scan setting |
|----------------------------------------------------------------------------------------------------------------------------|--------------------------------|---------------------|------------------------------------------------------------------------------------------------------|
| Option barcode | Option | Alpha. entry | |
| Read  %2101M% | Disable | 00 |  %2101D00% |
| | Enable | 01* |  %2101D01% * |
| Check digit verification  %2102M% | Disable | 00 |  %2102D00% |
| | Enable | 01* |  %2102D01% * |
| Check digit transmission  %2103M% | Disable | 00* |  %2103D00% * |
| | Enable | 01 |  %2103D01% |
| Max. code length  %2104M% | 00-99 | 00-99 | |
| | | 00* |  %2104D00% * |
| Min. code length  %2105M% | 00-99 | 00-99 | |
| | | 01* |  %2105D01% * |
| Code ID setting  %2106M% | 00-FF ₁₆ (ASCII) | 00-FF ₁₆ | |
| | | <L>* |  %2106H4C% * |
| Insert group selection  %2107M% | 00-66 | 00-66 | |
| | | 00* |  %2107D00% * |
|  %END% | | | |

7-19 Code 11

Read:

Format

| | | |
|------------------------|---------------------------|--------------------------|
| Data digits (variable) | Check digit 1 (optional) | Check digit 2 (optional) |
|------------------------|---------------------------|--------------------------|

Check digit verification: The check digit is presented as the sum module 11 of all data digits.

Check digit transmission: By setting Enable, check digit 1 and check digit 2 will be transmitted upon your selected check digit verification method.

Max./Min. code length: Refer to

| |
|-----------------------|
| Max./Min. code length |
|-----------------------|

 of “[7-10 Code 39](#)”.

Code ID setting: Refer to





















| |
|-----------------|
| Code ID setting |
|-----------------|

 of “[7-5 UPC-A](#)”.

Insertion group selection: Refer to

| |
|---------------------------|
| Insertion group selection |
|---------------------------|

 of “[7-5 UPC-A](#)”.

| Multiple-scan setting | | | Single-scan setting |
|--------------------------------------------------------------------------------------------------------------------------|--------------------------------|---------------------|------------------------------------------------------------------------------------------------------|
| Option barcode | Option | Alpha. entry | |
| Read  %2201M% | Disable | 00* |  %2201D00% * |
| | Enable | 01 |  %2201D01% |
| Check digit verification  %2202M% | Disable | 00 |  %2202D00% |
| | One digit | 01* |  %2202D01% * |
| | Reserved | 02 |  %2202D02% |
| | Reserved | 03 |  %2202D03% |
| Check digit transmission  %2203M% | Disable | 00* |  %2203D00% * |
| | Enable | 01 |  %2203D01% |
| Max. code length  %2204M% | 00-99 | 00-99 | |
| | | 00* |  %2204D00% * |
| Min. code length  %2205M% | 00-99 | 00-99 | |
| | | 00* |  %2205D00% * |
| Code ID setting  %2206M% | 00-FF ₁₆ (ASCII) | 00-FF ₁₆ | |
| | | <V>* |  %2206H56% * |
| Insert group selection  %2207M% | 00-66 | 00-66 | |
| | | 00* |  %2207D00% * |
|  %END% | | | |

7-20 MSI/Plessey

Read:

Format

| | | |
|------------------------|--------------------------|--------------------------|
| Data digits (variable) | Check digit 1 (optional) | Check digit 2 (optional) |
|------------------------|--------------------------|--------------------------|

Check digit verification: The MSI/Plessey has one or two optional check digits. There are three methods of verifying check digits, i.e. Mod10, Mod10/10 and Mod 11/10. The check digit 1 and check digit 2 will be calculated as the sum module 10 or 11 of the data digits.

Check digit transmission: By setting Enable, check digit 1 and check digit 2 will be transmitted upon your selected check digit verification method.

Max./Min. code length: Refer to

| |
|-----------------------|
| Max./Min. code length |
|-----------------------|

 of “*7-10 Code 39*”.

Code ID setting: Refer to





| |
|-----------------|
| Code ID setting |
|-----------------|

 of “*7-5 UPC-A*”.

Insertion group selection: Refer to

| |
|---------------------------|
| Insertion group selection |
|---------------------------|

 of “*7-5 UPC-A*”.

| Multiple-scan setting | | | Single-scan setting |
|--------------------------------------------------------------------------------------------------------------------------|--------------------------------|---------------------|------------------------------------------------------------------------------------------------------|
| Option barcode | Option | Alpha. entry | |
| Read  %2301M% | Disable | 00* |  %2301D00% * |
| | Enable | 01 |  %2301D01% |
| Check digit verification  %2302M% | Disable | 00* |  %2302D00% * |
| | 1 digit (mod 10) | 01 |  %2302D01% |
| | Reserved | 02 |  %2302D02% |
| | Reserved | 03 |  %2302D03% |
| Check digit transmission  %2303M% | Disable | 00* |  %2303D00% * |
| | Enable | 01 |  %2303D01% |
| Max. code length  %2304M% | 00-99 | 00-99 | |
| | | 00* |  %2304D00% * |
| Min. code length  %2305M% | 00-99 | 00-99 | |
| | | 00* |  %2305D00% * |
| Code ID setting  %2306M% | 00-FF ₁₆ (ASCII) | 00-FF ₁₆ | |
| | | <O>* |  %2306H4F% * |
| Insert group selection  %2307M% | 00-66 | 00-66 | |
| | | 00* |  %2307D00% * |



7-21 UK/Plessey

Read:

Format

| | |
|------------------------|---------------------------|
| Data digits (variable) | 2 check digits (optional) |
|------------------------|---------------------------|

Check digit verification: The UK/Plessey has one or two optional check digits. The check digit 1 and check digit 2 will be calculated as the sum module 10 or 11 of the data digits.

Check digit transmission: By setting Enable, check digit will be transmitted.

Max./Min. code length: Refer to Max./Min. code length of "7-10 Code 39".

Code ID setting: Refer to Code ID setting of "7-5 UPC-A".

Insertion group selection: Refer to Insertion group selection of "7-5 UPC-A".

| Multiple-scan setting | | | Single-scan setting |
|----------------------------------------------------------------------------------------------------------------------------|------------------------------------|---------------------|------------------------------------------------------------------------------------------------------|
| Option barcode | Option | Alpha. entry | |
| Read  %2401M% | Disable | 00* |  %2401D00% * |
| | Enable | 01 |  %2401D01% |
| Check digit verification  %2402M% | Disable | 00 |  %2402D00% |
| | Enable | 01* |  %2402D01% * |
| Check digit transmission  %2403M% | Disable | 00* |  %2403D00% * |
| | Enable | 01 |  %2403D01% |
| Max. code length  %2404M% | 00-99 | 00-99 | |
| | | 00* |  %2404D00% * |
| Min. code length  %2405M% | 00-99 | 00-99 | |
| | | 01* |  %2405D01% * |
| Code ID setting  %2406M% | 00-FF ₁ 6 (ASCII) | 00-FF ₁₆ | |
| | | <U>* |  %2406H55% * |
| Insert group selection  %2407M% | 00-66 | 00-66 | |
| | | 00* |  %2407D00% * |
|  %END% | | | |

7-22 China Post

Read:

Format

11 Data digits

Max. /Min. code length: Refer to **Max./Min. code length** of “7-10 Code 39”. The code length of China Post is 11.

Code ID setting: Refer to **Code ID setting** of “7-5 UPC-A”.

Insertion group selection: Refer to **Insertion group selection** of “7-5 UPC-A”.

| Multiple-scan setting | | | Single-scan setting |
|--------------------------------------------------------------------------------------------------------------------------|--------------------------------|---------------------|------------------------------------------------------------------------------------------------------|
| Option barcode | Option | Alpha. entry | |
| Read  %2601M% | Disable | 00 |  %2601D00% |
| | Enable | 01* |  %2601D01% * |
| Max. code length  %2604M% | 00-99 | 00-99 | |
| | | 11* |  %2604D11% * |
| Min. code length  %2605M% | 00-99 | 00-99 | |
| | | 11* |  %2605D11% * |
| Code ID setting  %2606M% | 00-FF ₁₆ (ASCII) | 00-FF ₁₆ | |
| | | <T>* |  %2606H54% * |
| Insert group selection  %2607M% | 00-66 | 00-66 | |
| | | 00* |  %2607D00% * |
|  %END% | | | |

7-23 GS1 DataBar (GS1 DataBar Truncated)

GS1 DataBar Truncated is structured and encoded the same as the standard GS1 DataBar format, except its height is reduced to a 13 modules minimum; while GS1 DataBar should have a height greater than or equal to 33 modules.

Read:

Format

16 Data digits



Code ID setting: Refer to **Code ID setting** of “7-5 UPC-A”.

Insertion group selection: Refer to **Insertion group selection** of “7-5 UPC-A”.

Conversion:

UCC/EAN 128- Refer to **Code ID transmission** of String transmission,]Cm will be identified as AIM ID.

UPC-A or EAN-13- Barcode beginning with a single zero as the first digit has the leading “010” stripped and the barcode reported as EAN-13. Barcode beginning with two or more zeros but not six zeros has the leading “0100” stripped and the barcode reported as UPC-A.

| Multiple-scan setting | | | Single-scan setting |
|--------------------------------------------------------------------------------------------------------------------------|--------------------------------|---------------------|------------------------------------------------------------------------------------------------------|
| Option barcode | Option | Alpha. entry | |
| Read  %2701M% | Disable | 00 |  %2701D00% |
| | Enable | 01* |  %2701D01% * |
| Code ID setting  %2702M% | 00-FF ₁₆ (ASCII) | 00-FF ₁₆ | |
| | | <R >* |  %2702H52% * |
| Insert group selection  %2703M% | 00-66 | 00-66 | |
| | | 00* |  %2703D00% * |
| Conversion  %2704M% | None | 00* |  %2704D00% * |
| | UCC/EAN 128 | 01 |  %2704D01% |
| | UPC-A or EAN-13 | 02 |  %2704D02% |



7-24 GS1 DataBar Limited

Read:











Format

16 Data digits

Code ID setting: Refer to Code ID setting of “7-5 UPC-A”.

Insertion group selection: Refer to Insertion group selection of “7-5 UPC-A”.

Conversion: Refer to Conversion of GS1 DataBar (GS1 DataBar Truncated).

| Multiple-scan setting | | | Single-scan setting |
|--------------------------------------------------------------------------------------------------------------------------|--------------------------------|---------------------|------------------------------------------------------------------------------------------------------|
| Option barcode | Option | Alpha. entry | |
| Read  %2801M% | Disable | 00 |  %2801D00% |
| | Enable | 01* |  %2801D01% * |
| Code ID setting  %2802M% | 00-FF ₁₆ (ASCII) | 00-FF ₁₆ | |
| | | <R >* |  %2802H52% * |
| Insert group selection  %2803M% | 00-66 | 00-66 | |
| | | 00* |  %2803D00% * |
| Conversion  %2804M% | None | 00* |  %2804D00% * |
| | UCC/EAN 128 | 01 |  %2804D01% |
| | UPC-A or EAN-13 | 02 |  %2804D02% |
|  %END% | | | |

7-25 GS1 DataBar Expanded

Read:

Format

Data characters (variable)

Code ID setting: Refer to Code ID setting of “7-5 UPC-A”.

Insertion group selection: Refer to Insertion group selection of “7-5 UPC-A”.

Conversion:

UCC/EAN 128- Refer to Code ID transmission of String transmission,]Cm will be identified as AIM ID.

| Multiple-scan setting | | | Single-scan setting |
|--------------------------------------------------------------------------------------------------------------------------|--------------------------------|---------------------|------------------------------------------------------------------------------------------------------|
| Option barcode | Option | Alpha. entry | |
| Read  %2901M% | Disable | 00 |  %2901D00% |
| | Enable | 01* |  %2901D01% * |
| Max. code length  %2902M% | 00-99 | 00-99 | |
| | | 00* |  %2902D00% * |
| Min. code length  %2903M% | 00-99 | 00-99 | |
| | | 01* |  %2903D01% * |
| Code ID setting  %2904M% | 00-FF ₁₆ (ASCII) | 00-FF ₁₆ | |
| | | <R >* |  %2904H52% * |
| Insert group selection  %2905M% | 00-66 | 00-66 | |
| | | 00* |  %2905D00% * |
| Conversion  %2906M% | None | 00* |  %2906D00% * |
| | UCC/EAN 128 | 01 |  %2906D01% |



7-26 China Finance

Note: This type of barcode is not Omni-directionally decodable. The encodable character set includes numeric 0 to 9. Among the symbol of 0 to 9, 0 and 2, 4 and 9, 5 and 8, 6 and 7, have the symmetrical pattern; the pattern of 1 and 3 is symmetrical.

Read:

Format

10 Data digits

Max./Min. code length: Refer to **Max./Min. code length** of “7-10 Code 39”.



Check digit verification: The check digit is made as the sum module 10 of the numerical values of all data digits.





















Leading character 5/6/7/8/9 converted to A/B/C/D/E: By setting, leading character 5/6/7/8/9 can be converted to A/B/C/D/E.

Leading character assignment: By setting, only the barcode with the assigned leading character can be output.

Code ID setting: Refer to **Code ID setting** of “7-5 UPC-A”.

Insertion group selection: Refer to **Insertion group selection** of “7-5 UPC-A”.

| Multiple-scan setting | | | Single-scan setting |
|---------------------------------------------------------------------------------------------------------------------------------------------------------|-----------------------|--------------|------------------------------------------------------------------------------------------------------|
| Option barcode | Option | Alpha. entry | |
| Read  %3201M% | Disable | 00 |  %3201D00% |
| | Enable | 01* | |
| Max. code length  %3202M% | 00-99 | 00-99 |  %3202D10% * |
| | | 10* | |
| Min. code length  %3203M% | 00-99 | 00-99 |  %3203D10% * |
| | | 10* | |
| Check digit verification  %3204M% | Disable | 00* |  %3204D00% * |
| | Reserved | 01 |  %3204D01% |
| Leading character 5/6/7/8/9 converted to A/B/C/D/E  %3205M% | Disable | 00 |  %3205D00% |
| | Enable | 01* |  %3205D01% * |
| | Only 5 converted to A | 02 |  %3205D02% |
| | Only 6 converted to B | 03 |  %3205D03% |





| Multiple-scan setting | | | Single-scan setting |
|-------------------------------------------------------------------------------------------------------------------------------|--------------------------------|---------------------|------------------------------------------------------------------------------------------------------|
| Option barcode | Option | Alpha. entry | |
| | Only 7 converted to C | 04 |  %3205D04% |
| | Only 8 converted to D | 05 |  %3205D05% |
| | Only 9 converted to E | 06 |  %3205D06% |
| Leading character assignment  %3206M% | Disable | 00 |  %3206D00% |
| | Assigned to 0 | 01* |  %3206D01% * |
| | Assigned to 5(A) | 02 |  %3206D02% |
| | Assigned to 6(B) | 03 |  %3206D03% |
| | Assigned to 7(C) | 04 |  %3206D04% |
| | Assigned to 8(D) | 05 |  %3206D05% |
| | Assigned to 9(E) | 06 |  %3206D06% |
| | Assigned to 1 | 07 |  %3206D07% |
| | Assigned to 2 | 08 |  %3206D08% |
| | Assigned to 3 | 09 |  %3206D09% |
| | Assigned to 4 | 10 |  %3206D10% |
| Code ID setting  %3207M% | 00-FF ₁₆ (ASCII) | 00-FF ₁₆ | |
| | | <Y>* |  %3207H59% * |
| Insert group selection  %3208M% | 00-66 | 00-66 | |
| | | 00* |  %3208D00% * |
|  %END% | | | |

7-27 PDF417

Read:

Format

Data characters (variable)





| Multiple-scan setting | | | Single-scan setting |
|------------------------------------------------------------------------------------------------------|---------|--------------|----------------------------------------------------------------------------------------------------|
| Option barcode | Option | Alpha. entry | |
| Read  %3001M% | Disable | 00 |  %3001D00% |
| | Enable | 01* |  %3001D01% * |
|  %END% | | | |

7-28 MicroPDF417

Read:

Format

Data characters (variable)





| Multiple-scan setting | | | Single-scan setting |
|------------------------------------------------------------------------------------------------------|---------|--------------|----------------------------------------------------------------------------------------------------|
| Option barcode | Option | Alpha. entry | |
| Read  %3101M% | Disable | 00 |  %3101D00% |
| | Enable | 01* |  %3101D01% * |
|  %END% | | | |

7-29 QR Code

Read:

Format

Data characters (variable)





| Multiple-scan setting | | | Single-scan setting |
|------------------------------------------------------------------------------------------------------|---------|--------------|----------------------------------------------------------------------------------------------------|
| Option barcode | Option | Alpha. entry | |
| Read  %4001M% | Disable | 00 |  %4001D00% |
| | Enable | 01* |  %4001D01% * |
|  %END% | | | |

7-30 Data Matrix

Read:

Format

Data characters (variable)





| Multiple-scan setting | | | Single-scan setting |
|------------------------------------------------------------------------------------------------------|---------|--------------|----------------------------------------------------------------------------------------------------|
| Option barcode | Option | Alpha. entry | |
| Read  %4101M% | Disable | 00 |  %4101D00% |
|  %4101M% | Enable | 01* |  %4101D01% * |
|  %END% | | | |

7-31 Han Xin Code

Read:

Format

Data characters (variable)

| Multiple-scan setting | | | Single-scan setting |
|------------------------------------------------------------------------------------------------------|---------|--------------|----------------------------------------------------------------------------------------------------|
| Option barcode | Option | Alpha. entry | |
| Read  %4201M% | Disable | 00 |  %4201D00% |
|  %4201M% | Enable | 01* |  %4201D01% * |





 %END%

7-32 Aztec Code

Read:

Format

Data characters (variable)

| Multiple-scan setting | | | Single-scan setting |
|------------------------------------------------------------------------------------------------------|---------|--------------|----------------------------------------------------------------------------------------------------|
| Option barcode | Option | Alpha. entry | |
| Read  %4301M% | Disable | 00 |  %4301D00% |
| | Enable | 01* |  %4301D01% * |
|  %END% | | | |

7-33 G1-G6 & C1-C3 & FN1 substitution string setting

Format of barcode data transmission

| Prefix | Code name | Preamble | Code ID | Code length | Code data | Code ID | Postamble | Suffix |
|--------|-----------|----------|---------|-------------|-----------|---------|-----------|--------|
|--------|-----------|----------|---------|-------------|-----------|---------|-----------|--------|

Suffix string setting: The <enter> key is represented in different ASCII when it is applied by different OS. For a Windows/DOS OS, <enter> is represented as <CR><LF> (0x0D 0x0A); for an Apple MAC OS, <enter> is represented as <CR> (0x0D); for a Linux/Unix OS, <enter> is represented as <LF> (0x0A).

Prefix/Suffix string setting: & Preamble/Postamble string setting:

They are appended to the data automatically when a barcode is decoded.

Example: Add a symbol of “\$” as a prefix for all symbols.

Steps:

- 1) Scan the option barcode of Prefix string setting.
- 2) Use the ASCII table to find the value of \$→24.
- 3) Scan 2 and 4 from the barcode on the last page.
- 4) Scan END barcode.

Scanning steps: Scan the following barcodes in order.

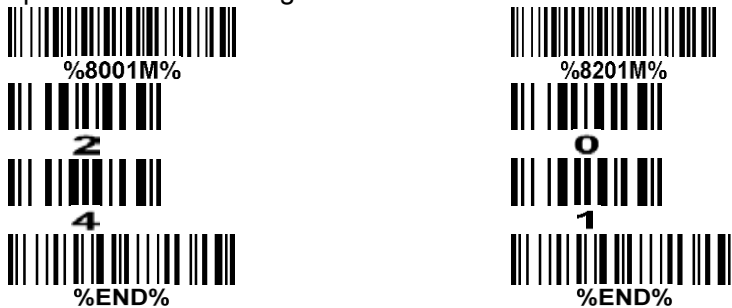

Insert G1/G2/G3/G4 string setting: The scanner offers 4 positions and 4 character strings to insert among the symbol.

Example: Set G1 string to be “AB”.

| | |
|--------------------|-------------------|
| Original code data | “1 2 3 4 5 6” |
| Output code data | “1 2 A B 3 4 5 6” |

Steps:

- 1) Scan the option barcode of Insert G1 string setting.
- 2) Use the ASCII table to find the value of A→41, B→42.
- 3) Scan 4, 1 and 4, 2 from the barcode on the last page.
- 4) Scan END barcode.
- 5) Refer to the chapter of “[7-34 G1-G4 string position & Code ID position](#)”.
- 6) Refer to the chapter of “[7-4 Global settings](#)”.



Testing barcode:



FN1 substitution string setting: The FN1 character (0x1D) in an UCC/EAN128 barcode, or a Code 128 barcode, or a GS1 DataBar barcode can be substituted with a defined string.

Truncate leading G5 string setting: By setting, a defined leading character or string can be truncated. Also a single character can be un-defined.

Repeat of a G5 character setting: While G5 is set as a single defined/un-defined character, G5 can also be set to be repeated. This setting is ignored when the truncate number is more than the barcode data characters. The option of “FF” for this setting is not active while the option of Truncate leading G5 string setting is “00”.

Example: Truncate all leading zeros for all symbols.

| | |
|--------------------|---------------------|
| Original code data | “0 0 0 1 2 3 4 5 6” |
| Output code data | “1 2 3 4 5 6” |

Steps: scan the following data in order.

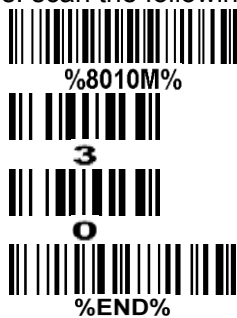

Testing barcode:



Truncate ending G6 string setting: By setting, a defined ending character or string can be truncated. Also a single character can be un-defined.

Repeat of a G6 character setting: While G5 is set as a single defined/un-defined character, G6 can also be set to be repeated. This setting is ignored when the truncate number is more than the barcode data characters. The option of “FF” for this setting is not active while the option of Truncate ending G6 string setting is “00”.

Single character C1/C2 replacement: By setting, a defined character in the data string can be replaced by another defined character. The C1 and C2 replacement can be applied simultaneously.

Example: Replace all the “A” character in a data string with “B” character.

| | |
|--------------------|---------------|
| Original code data | “1 2 3 A 5 A” |
| Output code data | “1 2 3 B 5 B” |

Steps: scan the following barcodes in order. The ASCII value for “A” is 41, and the ASCII value for “B” is 42.

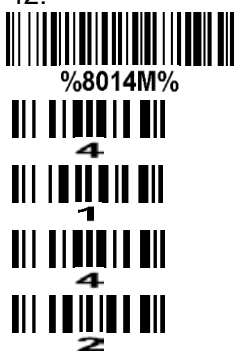



%END%

Testing barcode:



123A5A

Multiple characters C3 replacement: By setting, a number of defined characters in the data string can be replaced by other defined characters. The maximum number of characters to replace is 11.

Example: Replace all the “A” character in a data string with “B” character; replace “C” with “D”; replace “E” with “F”.

| | |
|--------------------|-------------------------|
| Original code data | “1 2 3 A 4 C 5 6 E 7 8” |
| Output code data | “1 2 3 B 4 D 5 6 F 7 8” |

Steps: scan the following barcodes in order. The ASCII value for “A” is 41, for “B” is 42, for “C” is 43, for “D” is “44”, for “E” is 45, and for “F” is 46.



%8016M%



4



1



4



2



4



3



4



4



4



5



4



6





%END%

Testing barcode:



123A4C56E78

| Multiple-scan setting | | | Single-scan setting |
|-----------------------------------------------------------------------------------------------------------------------------------------|-------------------------|---------------------|------------------------------------------------------------------------------------------------------|
| Option barcode | Option | Alpha. Entry | |
| Prefix string setting  %8001M% | 0-22 characters | 00-FF ₁₆ |  %8001H00% * |
| | None | 00* | |
| Suffix string setting  %8002M% | 0-22 characters | 00-FF ₁₆ | |
| | <ENTER> | 0D0A* | |
| Preamble string setting  %8003M% | 0-22 characters | 00-FF ₁₆ |  %8003H00% * |
| | None | 00* | |
| Postamble string setting  %8004M% | 0-22 characters | 00-FF ₁₆ |  %8004H00% * |
| | None | 00* | |
| Insert G1 string setting  %8005M% | 0-22 characters | 00-FF ₁₆ |  %8005H00% * |
| | None | 00* | |
| Insert G2 string setting  %8006M% | 0-22 characters | 00-FF ₁₆ |  %8006H00% * |
| | None | 00* | |
| Insert G3 string setting  %8007M% | 0-22 characters | 00-FF ₁₆ |  %8007H00% * |
| | None | 00* | |
| Insert G4 string setting  %8008M% | 0-22 characters | 00-FF ₁₆ |  %8008H00% * |
| | None | 00* | |
| FN1 substitution string setting  %8009M% | 0-4 characters | 00-FF ₁₆ |  %8009H20% * |
| | <SP> | 20* | |
| Truncate leading G5 string setting  %8010M% | A un-defined character | 00 |  %8010H00% |
| | 1-22 defined characters | 01-7F ₁₆ | |
| | <0> | 30* |  %8010H30% * |

| Multiple-scan setting | | | Single-scan setting |
|-----------------------------------------------------------------------------------------------------------------------------------------|-------------------------|-------------------------|---------------------------------------------------------------------------------------|
| Option barcode | Option | Alpha. Entry | |
| Repeat of a G5 character setting  %8011M% | Once | 01* |  * |
| | Defined times | 01-22 | |
| | Un-defined times (All) | FF |  * |
| Truncate ending G6 string setting  %8012M% | A un-defined character | 00 |  * |
| | 1-22 defined characters | 01-7F ₁₆ | |
| | <0> | 30* |  * |
| Repeat of a G6 character setting  %8013M% | Once | 01* |  * |
| | Defined times | 01-22 | |
| | Un-defined times (All) | FF |  * |
| Single character C1 replacement  %8014M% | <0000> | 0000* | |
| | | 0000-FFFF ₁₆ | |
| Single character C2 replacement  %8015M% | <0000> | 0000* | |
| | | 0000-FFFF ₁₆ | |
| Multiple characters C3 replacement  %8016M% | - | 0000* | |
| | | - | |
|  %END% | | | |

7-34 G1-G4 string position & Code ID position

Format of barcode data transmission

| | | | | | | | | |
|--------|-----------|----------|---------|-------------|-----------|---------|-----------|--------|
| Prefix | Code name | Preamble | Code ID | Code length | Code data | Code ID | Postamble | Suffix |
|--------|-----------|----------|---------|-------------|-----------|---------|-----------|--------|

Insert G1/G2/G3/G4 string position: The scanner offers 4 positions to insert strings among the symbol. In case of the insertion position is greater than the length of the symbol, the insertion of string is not effective.

Code ID position: It is allowed to select different positions of code ID placement.

| Multiple-scan setting | | | Single-scan setting |
|-----------------------------------------------------------------------------------------------------------------------------|------------------|--------------|------------------------------------------------------------------------------------------------------|
| Option barcode | Option | Alpha. entry | |
| Insert G1 string position  %8101M% | 00-99 | 00-99 |  %8101D00% * |
| | | 00* | |
| Insert G2 string position  %8102M% | 00-99 | 00-99 |  %8102D00% * |
| | | 00* | |
| Insert G3 string position  %8103M% | 00-99 | 00-99 |  %8103D00% * |
| | | 00* | |
| Insert G4 string position  %8104M% | 00-99 | 00-99 |  %8104D00% * |
| | | 00* | |
| Code ID position  %8105M% | Before code data | 00* |  %8105D00% * |
| | After code data | 01 |  %8105D01% |
|  %END% | | | |

7-35 String transmission

Note: The information in this chapter is closely related to the chapter of String setting.

Format of barcode data transmission

| | | | | | | | | |
|--------|-----------|----------|---------|-------------|-----------|---------|-----------|--------|
| Prefix | Code name | Preamble | Code ID | Code length | Code data | Code ID | Postamble | Suffix |
|--------|-----------|----------|---------|-------------|-----------|---------|-----------|--------|

Prefix transmission: By setting Enable, prefix will be appended before the data transmitted.

Suffix transmission: By setting Enable, suffix will be appended after the data is transmitted.

Code name transmission: By setting Enable, code name will be transmitted before code data.

Preamble transmission: By setting Enable, preamble will be appended before the data transmitted.

Postamble transmission: By setting Enable, postamble will be appended after the data is transmitted.

Code ID transmission: Code ID can be transmitted in the format of either Proprietary ID or AIM ID.

Refer to the chapter of Default setting for each barcode.

Code length transmission: The length of code data string can be transmitted before the code data when Enable is selected. The length is represented by a number with two digits.

Case conversion: The characters within code data or the whole output string can be set in either upper case or lower case.

FN1 substitution transmission: The scanner supports a FN1 substitution feature for keyboard wedge, USB and RS-232 interface. The replacement string of FN1 can be chosen by user (see chapter of "[7-33 G1-G6 & FN1 substitution string setting](#)").





























All-non-printable-character string transmission with string setting: By setting enable, all string settings, e.g.













or , are active for an all-non-printable-character string.

Here a non-printable character means a character with ASCII value between 0x00 to 0x1F.

Transmit the first N data characters only: The scanner supports to only transmit the first N data characters of a barcode. The number of N can be set as a digit between 1 and 99.

Transmit the last N data characters only: The scanner supports to only transmit the last N data characters of a barcode. The number of N can be set as a digit between 1 and 99.

| Multiple-scan setting | | | Single-scan setting |
|----------------------------------------------------------------------------------------------------------------------------|----------------------|--------------|------------------------------------------------------------------------------------------------------|
| Option barcode | Option | Alpha. entry | |
| Prefix transmission  %8201M% | Disable | 00* |  %8201D00% * |
| | Enable | 01 |  %8201D01% |
| Suffix transmission  %8202M% | Disable | 00 |  %8202D00% |
| | Enable | 01* |  %8202D01% * |
| Code name transmission  %8203M% | Disable | 00* |  %8203D00% * |
| | Enable | 01 |  %8203D01% |
| Preamble transmission  %8204M% | Disable | 00* |  %8204D00% * |
| | Enable | 01 |  %8204D01% |
| Postamble transmission  %8205M% | Disable | 00* |  %8205D00% * |
| | Enable | 01 |  %8205D01% |
| Code ID transmission  %8206M% | Disable | 00* |  %8206D00% * |
| | Proprietary ID | 01 |  %8206D01% |
| | AIM ID | 02 |  %8206D02% |
| Code length transmission  %8207M% | Disable | 00* |  %8207D00% * |
| | Enable | 01 |  %8207D01% |
| Case conversion  %8208M% | Disable | 00* |  %8208D00% * |
| | Upper (data only) | 01 |  %8208D01% |
| | Lower (data only) | 02 |  %8208D02% |
| | Upper (whole string) | 03 |  %8208D03% |
| | Lower (whole string) | 04 |  %8208D04% |
| FN1 substitution | Disable | 00* |  %8209D00% * |

| Multiple-scan setting | | | Single-scan setting |
|---------------------------------------------------------------------------------------------------------------------------------------------------------------------------|----------------------------------|--------------|----------------------------------------------------------------------------------------------------|
| Option barcode | Option | Alpha. entry | |
| transmission  %8209M% | Keyboard wedge/USB | 01 |  %8209D01% |
| | RS-232 | 02 |  %8209D02% |
| | Keyboard wedge / USB / RS-232 | 03 |  %8209D03% |
| All-non-printable-character string transmission with string setting  %8210M% | Disable | 00* |  %8210D00% * |
| | Enable | 01 |  %8210D01% |
| Transmit the first N data characters only  %8211M% | All | 99* |  %8211D99% * |
| | 01-99 | | |
| Transmit the last N data characters only  %8212M% | All | 99* |  %8212D99% * |
| | 01-99 | | |
|  %END% | | | |

8 Test Chart

UPC-A



UPC-E



UPC-E1



EAN-8



EAN-13



Code 39



Code 32



Code 128



Interleaved 2 of 5



Industrial 2 of 5
(Default setting: Read disable)



Matrix 2 of 5



Code 93



UCC/EAN 128



ISBT 128



Code 11
(Default setting: Read disable)



MSI/Plessey
(Default setting: Read disable)



Codabar



UK/Plessey



ISBN/ISSN



China Post



GS1 DataBar (GS1 DataBar Truncated)



GS1 DataBar Limited



GS1 DataBar Expanded



PDF417



12=890ab-+%xyz

MicroPDF417



23+-mdo

QR code



1234567890ABCD-+()&*%^@#S!XYZ

Data Matrix



123890abc-+=&*%^!mdo

Aztec Code

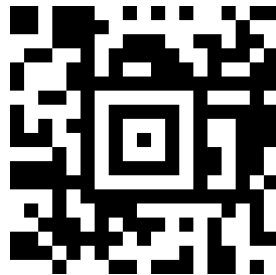

12345678901234567890

Han Xin Code

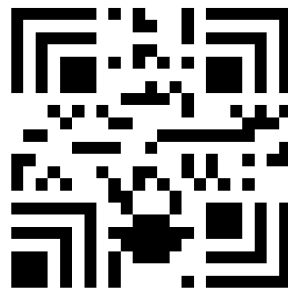

12345678901234567890

9 ASCII Table

| | | for keyboard wedge | | for RS-232 | |
|--------|--------|--------------------|-----|------------|--|
| H L | 0 | 1 | 0 | 1 | |
| 0 | Null | | NUL | DLE | |
| 1 | Up | F1 | SOH | DC1 | |
| 2 | Down | F2 | STX | DC2 | |
| 3 | Left | F3 | ETX | DC3 | |
| 4 | Right | F4 | EOT | DC4 | |
| 5 | PgUp | F5 | ENQ | NAK | |
| 6 | PgDn | F6 | ACK | SYN | |
| 7 | | F7 | BEL | ETB | |
| 8 | Bs | F8 | BS | CAN | |
| 9 | Tab | F9 | HT | EM | |
| A | | F10 | LF | SUB | |
| B | Home | Esc | VT | ESC | |
| C | End | F11 | FF | FS | |
| D | Enter | F12 | CR | GS | |
| E | Insert | Ctrl+ | SO | RS | |
| F | Delete | Alt+ | SI | US | |

Notes: The 2nd and the 3rd columns above are used for keyboard wedge only.

| H L | 2 | 3 | 4 | 5 | 6 | 7 |
|--------|----|---|---|---|---|-----|
| 0 | SP | 0 | @ | P | ` | p |
| 1 | ! | 1 | A | Q | a | q |
| 2 | “ | 2 | B | R | b | r |
| 3 | # | 3 | C | S | c | s |
| 4 | \$ | 4 | D | T | d | t |
| 5 | % | 5 | E | U | e | u |
| 6 | & | 6 | F | V | f | v |
| 7 | ‘ | 7 | G | W | g | w |
| 8 | (| 8 | H | X | h | x |
| 9 |) | 9 | I | Y | i | y |
| A | * | : | J | Z | j | z |
| B | + | ; | K | [| k | { |
| C | , | < | L | \ | l | |
| D | - | = | M |] | m | } |
| E | . | > | N | ^ | n | ~ |
| F | / | ? | O | _ | o | DEL |

Example: ASCII “A” = “41”.

10 Barcode representing non-printable character

Notes to make the following barcode:

1. According to different barcode printing software, the method of printing following barcode is different.
2. If using CODESOFT software, firstly read the information through “Help→Index→Code128→Special input syntax”. Also refer to ASCII table. For example, if we wish to make “F1” barcode, select “code128”, then select “CODE A” type, and input “{DOC1}” as data.



Up ↑



Down ↓



Left ←



Right →



Page Up



Page Down



Backspace



Tab



Home



End



Enter



Insert



Delete



F1



F2



F3



F4



F5



F6



F7



F8



F9



F10



Esc



F11



F12

11 Configuration alphanumeric entry barcode



0



1



2



3



4



5



6



7



8



9



A



B



C



D



E



F

FCC STATEMENT

1. This device complies with Part 15 of the FCC Rules. Operation is subject to the following two conditions:

(1) This device may not cause harmful interference.

(2) This device must accept any interference received, including interference that may cause undesired operation.

2. Changes or modifications not expressly approved by the party responsible for compliance could void the user's authority to operate the equipment.

NOTE: This equipment has been tested and found to comply with the limits for a Class B digital device, pursuant to Part 15 of the FCC Rules. These limits are designed to provide reasonable protection against harmful interference in a residential installation.

This equipment generates uses and can radiate radio frequency energy and, if not installed and used in accordance with the instructions, may cause harmful interference to radio communications. However, there is no guarantee that interference will not occur in a particular installation. If this equipment does cause harmful interference to radio or television reception, which can be determined by turning the equipment off and on, the user is encouraged to try to correct the interference by one or more of the following measures:

- Reorient or relocate the receiving antenna.

- Increase the separation between the equipment and receiver.

- Connect the equipment into an outlet on a circuit different from that to which the receiver is connected.

- Consult the dealer or an experienced radio/TV technician for help.

FCC Radiation Exposure Statement:

This equipment complies with FCC radiation exposure requirement.

The device can be used in portable exposure condition without RF striction

EU Regulatory Conformance

The equipment is in compliance with the essential requirements and other relevant provisions of the Directive 1999/5/EC.

CE 0197