

USER MANUAL

Cyberlink IEEE 802.11 b/g/n Wireless LAN

1.1 Name

Name: Cyberlink

Model: WM1010BGN

P/N: 051-000811-00

1.2 Version

Version 1.0

1.3 General Description

1.3.1 Product Overview and Functional Description

Shenzhen Mindray BIO-Medical Electronics CO.,LTD. introduces the first IEEE 802.11b/g /n WLAN module, ---Cyberlink. The module is targeted to Wireless Data communication of Mindray product.

The Cyberlink module is capable of footprint package, low power consumption, multiple interfaces and OS support.

By using Cyberlink, the customers can easily enable the Wi-Fi embedded applications with the benefits of high design flexibility, short development cycle, and quick time-to-market.

Compliance with the IEEE 802.11b/g/n standard, the Cyberlink uses Direct Sequence Spread Spectrum (DSSS) and Orthogonal Frequency Division Multiplexing (OFDM) baseband modulation technologies. The Cyberlink supports SDIO for WLAN to the host processor.

1.3.2 Key Features

Compatible with IEEE 802.11b high rate standard to provide wireless 11Mbps data rate

Compatible with IEEE 802.11g higher speed standard to provide wireless 54Mbps data rate

Compatible with IEEE 802.11n higher speed standard to provide wireless 65Mbps data rate

SDIO interfaces support for WLAN

Antenna Diversity: Select antenna depend on signal strength.

Multiple power saving modes for low power consumption.

Antenna Type: Rod Antenna; Tape Antenna; PCB Antenna;

Antenna Gain: 2 dBi for all above antennas

Notes: Bluetooth function was disabled.

1.4 User/service manuals

PIN Descriptions

No.	Pin name	Type	System	Description
1	SD_CLK	I	WLAN	SDIO Clock.
2	VIN	I	Common	3.3V Power supply input.
3	SD_CMD	I/O	WLAN	SDIO Command Line.
4	GND	I	Common	Ground.
5	SD_D0	I/O	WLAN	SDIO Data Line 0.
6	/WL_RESET	I	WLAN	Low asserting reset for WLAN core.
7	SD_D1	I/O	WLAN	SDIO Data Line 1.
8	SLEEP_CLK	I	Common	Low Power Clock input (32.768kHz).
9	SD_D2	I/O	WLAN	SDIO Data Line 2.
10	POW_ON	I	Common	Used by PMU to decide whether or not to power down internal BCM4329 regulators. If POW_ON is low, then the regulators will be disabled.
11	/CD	O	Common	Cyberlink On-line Detect. PIN tie to ground.
12	NC			No use
13	SD_D3	I/O	WLAN	SDIO Data Line 3.
14	VIN	I	Common	3.3V Power Input
15	LED	O	Common	3.3V Output
16	VIN	I	Common	3.3V Power Input
17	GND	I	Common	Ground.
18	GND	I	Common	Ground.
19	WL_WAKE_IN	I	WLAN	WLAN device wake-up signal input from host to WLAN.
20	BT_UART_TXD	O	BT	Bluetooth UART serial output .Serial data output for the HCI UART interface.
21	NC			No use
22	BT_UART_RXD	I	BT	Bluetooth UART serial input. Serial data input for the HCI UART interface.
23	NC			No use
24	BT_UART_RTS	O	BT	Bluetooth UART request to send. Active-low request-to-send signal for the HCI UART interface.
25	SW1	I	Common	Antenna select. SW1 and SW2 are floating, Select antenna 1 SW1=1,SW2=0,Select antenna 1

				SW1=0,SW2=1,Select antenna 2
26	BT_UART_CTS	I	BT	Bluetooth UART clear to send. Active-low clear-to-send signal for the HCI UART interface.
27	SW2	I	Common	Antenna select. SW1 and SW2 are floating, Select antenna 1 SW1=1,SW2=0,Select antenna 1 SW1=0,SW2=1,Select antenna 2
28	TYPE	O	Common	Cyberlink type Detect. PIN tie to 3.3V.
29	GND	I	Common	Ground.
30	VIN	I	Common	3.3V Power Input
31	/BT_RESET	I	BT	Low asserting reset for Bluetooth core.
32	BT_WAKE_IN	I	BT	Bluetooth device wake-up signal input from host to Bluetooth. The polarity of this signal is software configurable and can be asserted high or low.
33	BT_WAKE_OUT	O	BT	Host wake-up signal output from WLAN to host.
34	GND	I	Common	Ground.
35	NC			Tie 10k to ground
36	WL_WAKE_OUT	O	WLAN	Host wake-up signal output from WLAN to host.
37	BT_PCM_CLK	I/O	BT	PCM clock, can be master (output) or slave (input).
38	NC			Reserved for MIMO
39	BT_PCM_SYNC	I/O	BT	PCM sync signal, can be master (output) or slave (input).
40	GND	I	Common	Ground.
41	BT_PCM_OUT	I	BT	PCM data input.
42	NC			No use
43	BT_PCM_IN	O	BT	PCM data output.
44	NC			Reserved for MIMO
45	NC			No use
46	NC			Reserved for MIMO
47	NC			No use
48	NC			No use
49	WL_TXD	O	WLAN	TX pin of debug UART
50	NC			No use

51	WL_RXD	I	WLAN	RX pin of debug UART
52	NC			No use

1.7.2 Power On Sequence

1.7.2.1 Power On Sequence 1

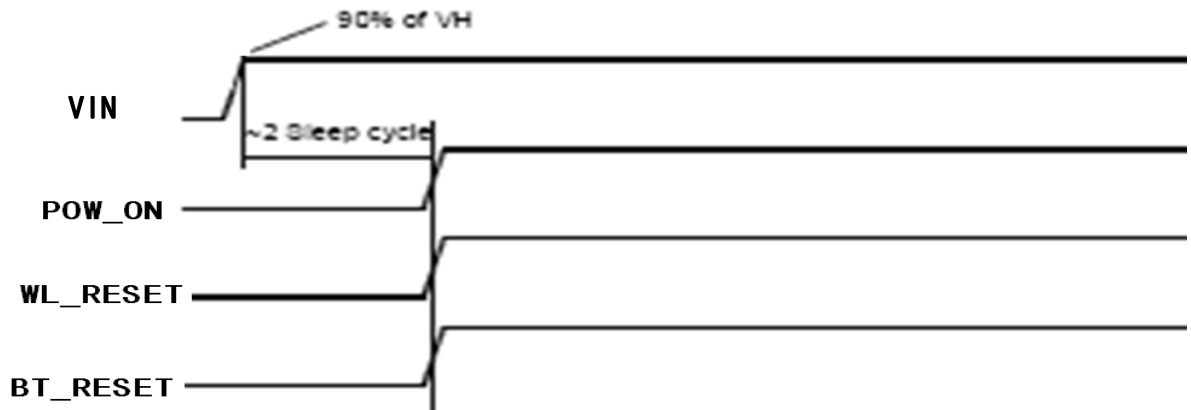

Figure 2 Power On Sequence 1

1.7.2.2 Power On Sequence 2

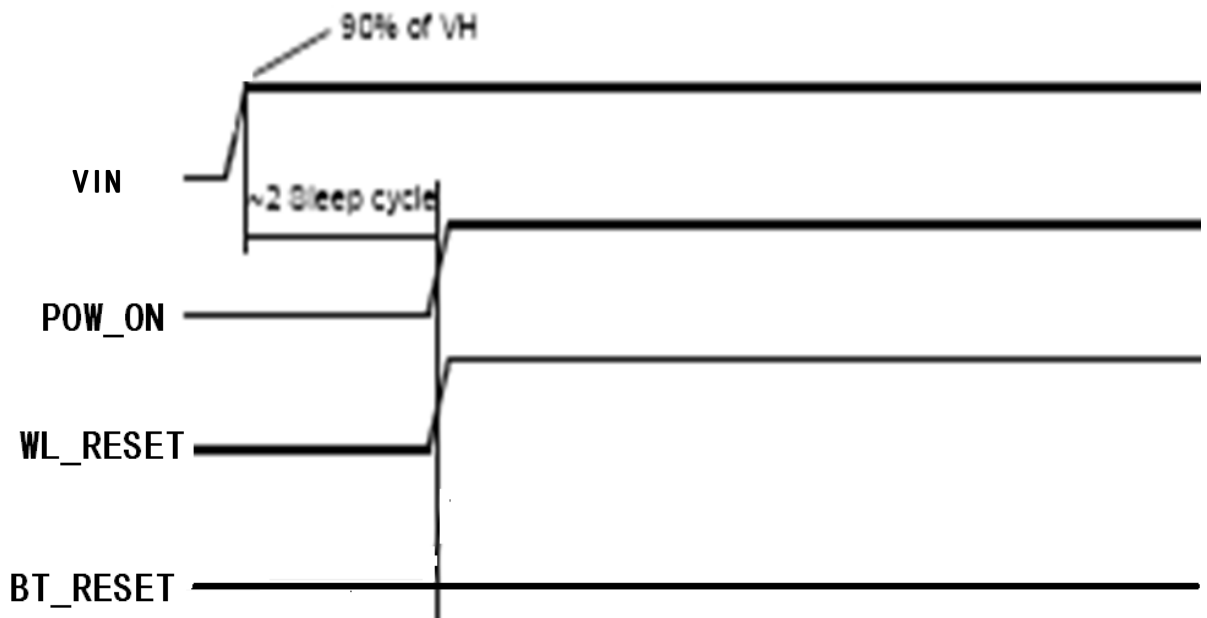

Figure 3 Power On Sequence 2

1.7.2.3 Power On Sequence 3

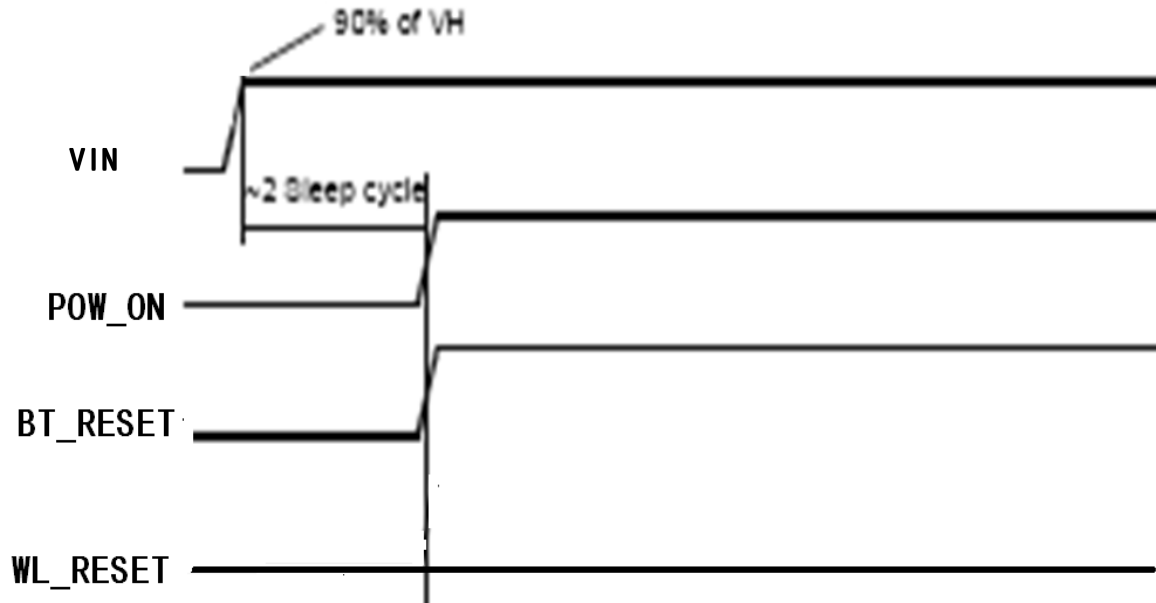

Figure 4 Power On Sequence 3

1.7.3 Interface

1.7.3.1 External Clock Reference (SLEEP_CLK)

Table 7 External Clock Reference

Parameter	Description	Remarks
Nominal input frequency	32.768 KHz	
Frequency accuracy	+/-200 ppm	
Duty cycle	30-70 %	
Input signal amplitude	200 to 1800 mVp-p	200-1800 mVp-p to avoid additional current consumption. 3.3Vp-p maximum.
Signal type	Square-wave or sine-wave	
Input impedance	100K Ω ; < 5 pF when power is applied or power is off	
Clock jitter (integrated over 300Hz – 15kHz)	<1 Hz	

1.7.3.2 Input/Output DC Terminal Characteristics

Table 8 Input/Output DC Terminal Characteristics

Digital Terminals		Min	Typ	Max	Unit
Input Voltage	V _{IL} input logic level low	-	-	0.8	V
	V _{IH} input logic level high	2.0	-	-	V

Output Voltage	V _{OL} output logic level low (100 μ A load)	-	-	0.4	V
	V _{OH} output logic level high (-100 μ A load)	2.4	-	-	V
Input Current:	I _{IL} input logic level low	-	0.3	-	uA
	I _{IH} input logic level high	-	0.3	-	uA
Output Current	I _{OL} output logic level low (V _{OL} =0.4V)	-	-	3.0	mA
	I _{OH} output logic level high (V _{OH} =2.9V)	-	-	3.0	mA
Input Capacitance :C _{IN}		-	-	5	pF

1.7.3.3 WLAN SDIO Timing

1.7.3.3.1 Default Mode

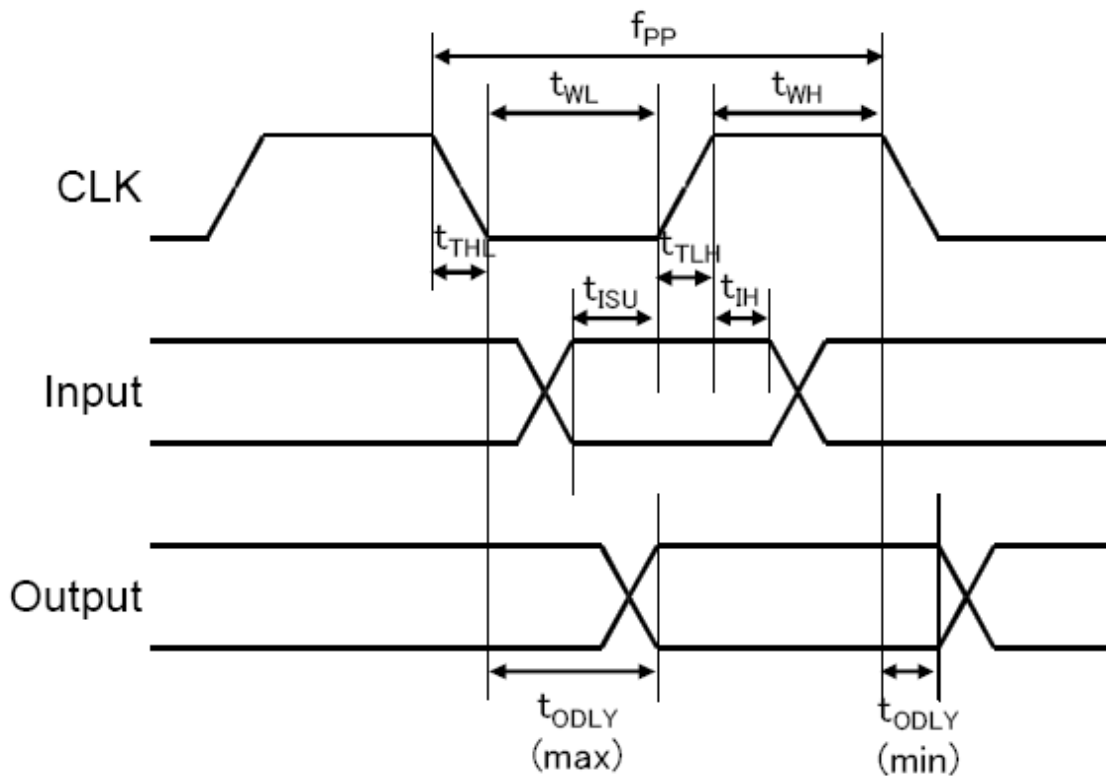

Figure 5 WLAN SDIO Timing, Default Mode

Table 9 WLAN SDIO Timing, Default Mode

Parameter		Symbol	Min	Typ	Max	Unit
Clock CLK (All values are referred to min. V _{IH} and max. V _{IL}) Min (V _{IH}) = 0.7*V _{IN} and max (V _{IL}) = 0.2*V _{IN}	Frequency-Data Transfer Mode	f _{PP}	0	-	25	MHz
	Frequency-Identification Mode	f _{OD}	0	-	400-	KHz
	Clock Low Time	t _{WL}	10	-	-	ns
	Clock High Time	t _{WH}	10	-	-	ns
	Clock Rise Time	t _{TLH}	-	-	10	ns
	Clock Falling Time	t _{THL}	-	-	10	ns
Inputs: CMD, DAT	Input Setup Time	t _{ISU}	5	-	-	ns

(referenced to CLK)	Input Hold Time	tIH	5	-	-	ns
Outputs: CMD, DAT (referenced to CLK)	Output Delay time-Data Transfer Mode	tODLY	-	-	14	ns
	Output Delay time-Identification Mode	tODLY	-	-	50	ns

Remark: Timing is based on CL < 40pF load on CMD and Data.

1.7.3.3.2 High Speed Mode

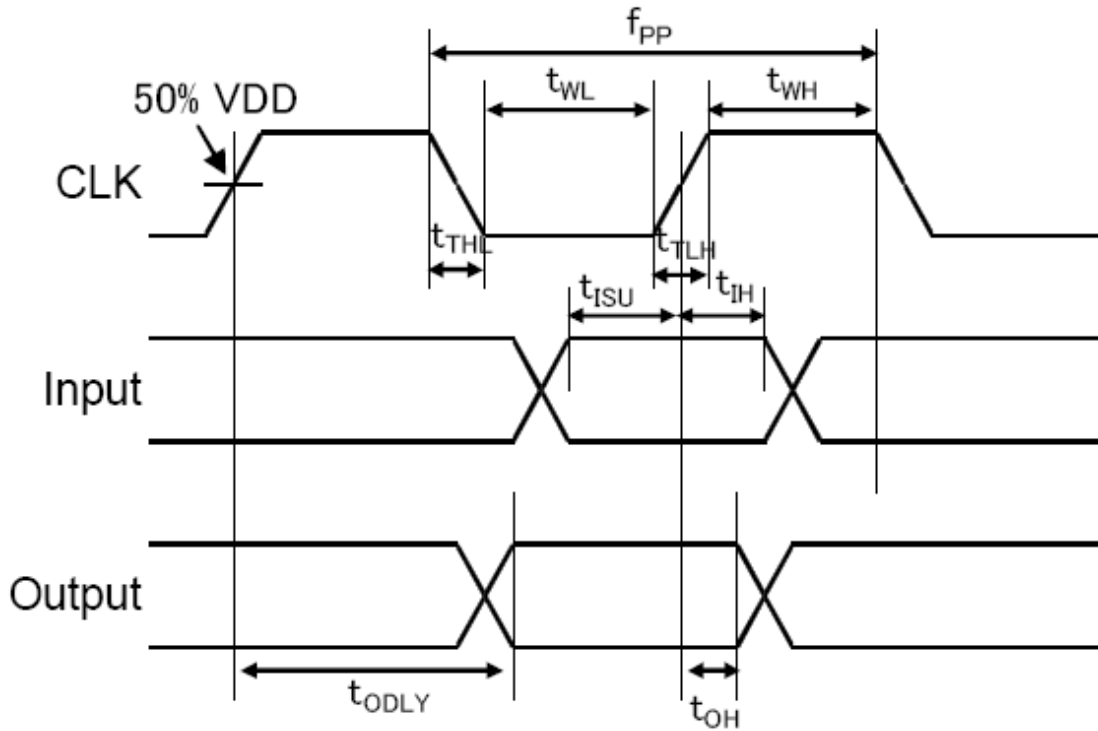

Figure 6 WLAN SDIO Timing, High Speed Mode

Table 10 WLAN SDIO Timing, High Speed Mode

Parameter		Symbol	Min	Typ	Max	Unit
Clock CLK (All values are referred to min. VIH and max. VIL) Min (Vih) = 0.7*VIN and max (Vil) = 0.2*VIN	Frequency-Data Transfer Mode	fPP	0	-	50	MHz
	Frequency-Identification Mode	fOD	0	-	400-	KHz
	Clock Low Time	tWL	7	-	-	ns
	Clock High Time	tWH	7	-	-	ns
	Clock Rise Time	tTLH	-	-	3	ns
	Clock Falling Time	tTHL	-	-	3	ns
Inputs: CMD, DAT (referenced to CLK)	Input Setup Time	tISU	6	-	-	ns
	Input Hold Time	tIH	2	-	-	ns
Outputs: CMD, DAT	Output Delay time-Data	tODLY	-	-	14	ns

(referenced to CLK)	Transfer Mode					
	Output Hold time	tOH	-	-	50	ns
	Total System Capacitance (each line)	CL	-	-	40	pF

Remark: Timing is based on CL < 40pF load on CMD and Data.

1.7.4 Mechanical

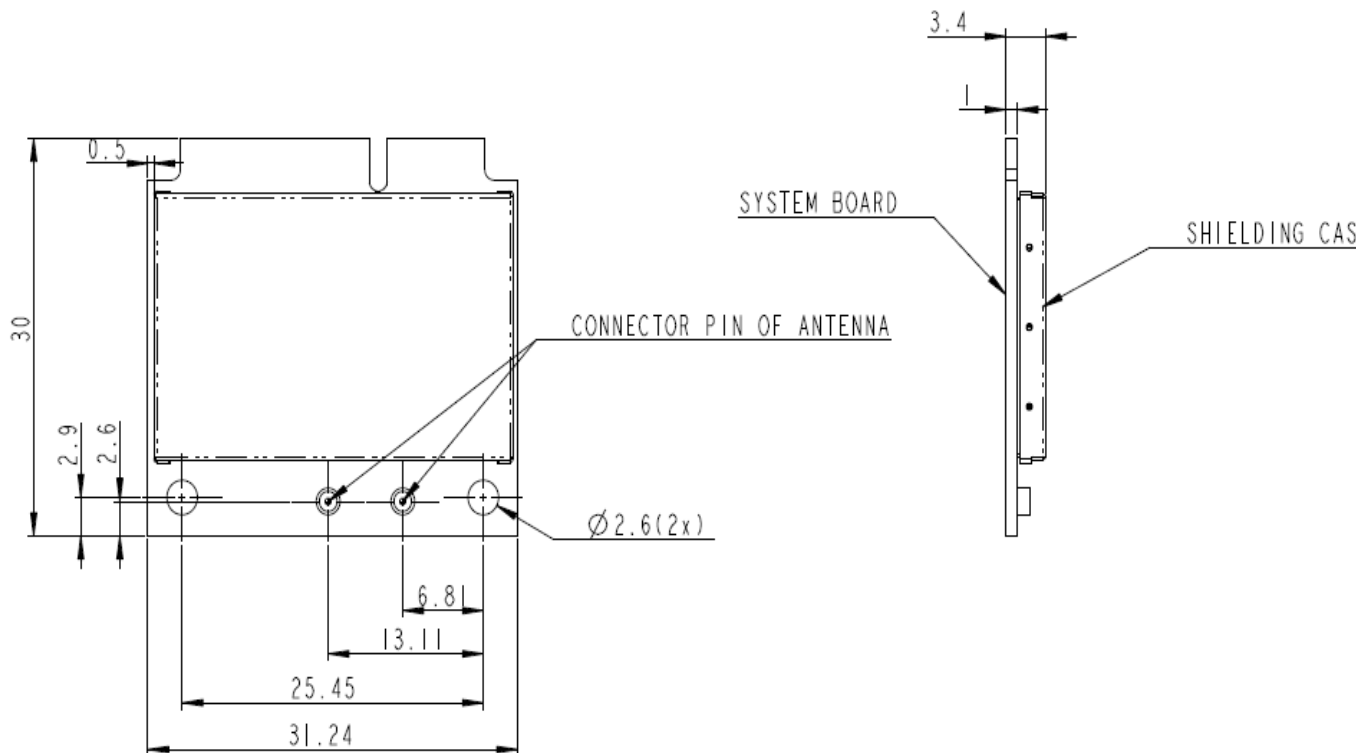

This device complies with Industry Canada licence-exempt RSS standard(s). Operation is subject to the following two conditions: (1) this device may not cause interference, and (2) this device must accept any interference, including interference that may cause undesired operation of the device.

Le présent appareil est conforme aux CNR d'Industrie Canada applicables aux appareils radio exempts de licence. L'exploitation est autorisée aux deux conditions suivantes : (1) l'appareil ne doit pas produire de brouillage, et (2) l'utilisateur de l'appareil doit accepter tout brouillage radioélectrique subi, même si le brouillage est susceptible d'en compromettre le fonctionnement.

The distance between user and products should be no less than 20cm

La distance entre l'utilisateur et de produits ne devrait pas être inférieure à 20cm

The host device must be labelled to display the IC ID of the module "Contains IC: 9726A-WM1010BGN10"

Appendix A FCC

A.1 FCC statement in User's Manual (for class B)

"Federal Communications Commission (FCC) Statement This Equipment has been tested and found to comply with the limits for a class B digital device, pursuant to Part 15 of the FCC rules. These limits are designed to provide reasonable protection against harmful interference in a residential installation. This equipment generates, uses and can radiate radio frequency energy and, if not installed and used in accordance with the instructions, may cause harmful interference to radio communications. However, there is no guarantee that interference will not occur in a particular installation. If this equipment does cause harmful interference to radio or television reception, which can be determined by turning the equipment off and on, the user is encouraged to try to correct the interference by one or more of the following measures:

- Reorient or relocate the receiving antenna.
- Increase the separation between the equipment and receiver.
- Connect the equipment into an outlet on a circuit different from that to which the receiver is connected.
- Consult the dealer or an experienced radio/TV technician for help.

A.2 FCC Statements:

1. This device complies with Part 15 of the FCC rules. Operation is subject to the following two conditions:
 - This device may not cause harmful interference,
 - and This device must accept any interference received, including interference that may cause undesired operation.
2. This device and its antenna(s) must not be co-located or operating in conjunction with any other antenna or transmitter.
3. Changes or modifications to this unit not expressly approved by the party responsible for compliance could void the user authority to operate the equipment.
4. This compliance to FCC radiation exposure limits for an uncontrolled environment, the minimum of 20 cm separation distance shall be maintained between antenna and body.

The host device must be labelled to display the FCC ID of the module "Contains FCC ID: ZLZWM1010BGN10"
