

# MiCare<sup>™</sup>

Nurse Call and Emergency System



# Table of Contents

<b>1.0</b>	<b>Introducing the MiCare Nurse Call and Emergency System</b>	<b>6</b>
1.1	Overview of the MiCare Nurse Call and Emergency System .....	7
1.2	Contact Us .....	9
<b>2.0</b>	<b>Installing the NC-2100K Coordinator Bundle</b>	<b>10</b>
2.1	Overview .....	11
2.2	Dimensions .....	11
2.3	LEDs .....	12
2.4	USB and Power .....	13
2.5	Mounting .....	15
2.6	Maintenance and Service .....	15
<b>3.0</b>	<b>Installing the NC-2000 Patient Unit</b>	<b>16</b>
3.1	Overview .....	17
3.2	Telephone Connections .....	18
3.3	Inputs .....	20
3.4	Dome Lights and Generic Outputs .....	21
3.5	Paging Input .....	25
3.6	Bed Cords .....	26
3.7	Secondary Ultrasound Transmitter .....	27
3.8	Power .....	27
3.9	Mounting the Patient Unit .....	29
3.10	LED Status Indicators .....	30
3.11	Maintenance and Service .....	31
3.12	Restarting the Patient Unit .....	31
<b>4.0</b>	<b>Installing the NC-210/NC-211 Beacon</b>	<b>32</b>
4.1	Overview .....	33
4.2	NC-210 .....	33
4.3	NC-211 .....	34
4.4	Installing the Beacon .....	37
4.5	Maintenance and Service .....	37
<b>5.0</b>	<b>Installing the NC-103 Pull Station</b>	<b>38</b>
5.1	Overview .....	39
5.2	Input .....	40
5.3	Power .....	40
5.4	Mounting the Pull Station .....	40
5.5	LED Status Indicator and Beeper .....	41
5.6	Maintenance and Service .....	42

<b>6.0</b>	<b>Installing the NC-220 ZF3</b>	<b>43</b>
6.1	Overview .....	44
6.2	Inputs .....	44
6.3	Power .....	45
6.4	Mounting the ZF3 .....	45
6.5	Maintenance and Service .....	45
<b>7.0</b>	<b>Installing The NC-500 Pendant</b>	<b>46</b>
7.1	Overview .....	47
7.2	LED Status Indicator .....	47
7.3	Using the Pendant .....	48
7.4	Canceling the Message from the Pendant .....	48
7.5	Maintenance and Service .....	48
<b>8.0</b>	<b>Appendix 1: Specifications</b>	<b>50</b>
8.1	NC-2000 Patient Unit .....	50
8.2	NC-210 Beacon .....	51
8.3	NC-211 Beacon .....	52
8.4	NC-103 Pull Station .....	52
8.5	NC-220 ZF3 3 Input Transmitter (auxiliary device for supplementary operation) .....	53
8.6	NC-500 Pendant .....	54
8.7	NC-2100K Coordinator Bundle .....	54
8.8	RB-MD-990 Power Supply for UL 2560 Applications Only .....	55
<b>9.0</b>	<b>Appendix 2: UL 2560 Requirements for UPS (Uninterruptible Power Supply)</b>	<b>56</b>
9.1	Server and Monitor .....	56
9.2	Coordinator Bundles, Beacons, and Patient Units .....	56
<b>10.0</b>	<b>Appendix 3: Wiring Diagram for Emergency Call System (UL 2560)</b>	<b>57</b>
<b>11.0</b>	<b>Appendix 4: Wiring Diagram for Nurse Call System (UL 1069)</b>	<b>58</b>
<b>12.0</b>	<b>Appendix 5: Device Installation Table</b>	<b>59</b>
<b>13.0</b>	<b>Warranty and Warning Information</b>	<b>61</b>
<b>14.0</b>	<b>Special Notices</b>	<b>64</b>

## List of Figures

Figure 1	A two-bed suite with some typical Nurse Call and Emergency System devices installed	8
Figure 2	Dimensions of the NC-2100K Coordinator Bundle (1U model)	11
Figure 3	Dimensions of the NC-2100K Coordinator Bundle (2U model)	12
Figure 4	The front of the NC-2100K Coordinator Bundle (1U model)	12
Figure 5	The front of the NC-2100K Coordinator Bundle (2U model)	13
Figure 6	Location of the USB and power terminals on the back of the NC-2100K Coordinator Bundle (1U model)	13
Figure 7	Location of the USB and power terminals on the back of the NC-2100K Coordinator Bundle (2U model)	14
Figure 8	NC-2100K (1U model) mounted to a wall	15
Figure 9	NC-2100K (2U model) mounting holes	15
Figure 10	The front of the NC-2000 Patient Unit	17
Figure 11	Telephone interface terminals CN1 and CN2	18
Figure 12	Input connections on CN6	20
Figure 13	Dome light connections on terminal CN16	21
Figure 14	NC-4LED connections on terminal CN16	23
Figure 15	Generic output connections on terminal CN13.	24
Figure 16	External paging input terminal CN2	25
Figure 17	Paging amplifier - 25 V output	25
Figure 18	Paging amplifier - 75 V output	26
Figure 19	Bed cord input terminal CN3	26
Figure 20	External ultrasonic emitter terminal CN14	27
Figure 21	Power terminal CN11 and jumpers J3 and J4	28
Figure 22	Battery terminal CN8	29
Figure 23	Patient Unit mounting plate	30
Figure 24	The front of the NC-210 Beacon	33
Figure 25	The front of the NC-211 Beacon	34
Figure 26	NC-211 (back view)	35
Figure 27	JW1 on NC-211	36
Figure 28	The front of the NC-103 Pull Station	39
Figure 29	Pull Station mounting plate	41
Figure 30	Input terminals TS1 and TS2 on the NC-220 ZF3.	45
Figure 31	The front of the NC-500 Pendant	47
Figure 32	Use a small screwdriver to open the case	48
Figure 33	Pendant with bottom half of case removed	49

# 1.0 Introducing the MiCare Nurse Call and Emergency System

This chapter gives you a brief introduction to the MiCare Nurse Call and Emergency System, its application, and the types of devices that make up the Nurse Call and Emergency System.

**In this chapter you will find:**

- Overview of the MiCare Nurse Call and Emergency System
- Contact Us

## 1.1 Overview of the MiCare Nurse Call and Emergency System

The MiCare Nurse Call and Emergency System from Mircom is an advanced nurse call solution that couples wireless mesh networking technology with ultrasonic signalling to accurately identify and respond to emergency events. To achieve this, the Nurse Call and Emergency System uses the highly reliable 802.15.4 wireless network. This network technology provides a self-forming, self-healing mesh type transport when routing messages to and from the Nurse Call and Emergency System Central server.

There are three types of devices that make up the Nurse Call and Emergency System:

- **Coordinators:** Coordinators connect to the Nurse Call and Emergency System Central server through a USB connection. They communicate on the 802.15.4 wireless network but are not programmed with the MiCare Nurse Call and Emergency System firmware. Their sole purpose is to transport messages back and forth between the Central server and the routers on the 802.15.4 wireless network.
- **Routers:** Routers communicate with the Central server through the coordinators on the Nurse Call and Emergency System. They are programmed with the MiCare Nurse Call and Emergency System application firmware. Routers also listen for messages from end devices on the system, which they then pass on to the Central server. Finally, routers come with ultrasound transmitters that are used to locate portable MiCare end devices.
- **End Devices:** End devices send messages about their status wirelessly to the 802.15.4 network. They do not communicate directly with the Central server. Their messages are instead passed on to the Central server through a router on the network. End devices are not programmed with the Nurse Call and Emergency System application firmware.

Figure 1 shows a typical Nurse Call and Emergency System installation in a two-bed suite. This installation includes examples of both routers and end devices.

**Table 1 Devices in the Nurse Call and Emergency System**

Device	Type	Description
<b>NC-2100K Coordinator Bundle</b>	Coordinator	The Coordinator Bundle passes messages between the routers and the Central server in the Nurse Call and Emergency System.
<b>NC-2000 Patient Unit</b>	Router	The Patient Unit is ideally suited for patient rooms. Some of its features include inputs for 2 bed cords, two-way voice communication, an ultrasound transmitter, and outputs for 4-light dome lights, such as the NC-4LED corridor light.
<b>NC-210 and NC-211 Beacon</b>	Router	The Beacon is used to extend the range of a Patient Unit or for use in areas where a Patient Unit is not required (for example, a hallway). It has an ultrasound transmitter for locating end devices.
<b>NC-103 Pull Station</b>	End Device	The Pull Station is a battery powered transmitter with a pull cord, 3 buttons, and an external input. These features make the Pull Station an ideal accessory to the Patient Unit, providing emergency call capability in areas where a Patient Unit is not required or feasible.

**Table 1 Devices in the Nurse Call and Emergency System**

Device	Type	Description
<b>NC-220 ZF3</b>	End Device	The ZF3 is a battery powered transmitter with 3 inputs (one cancel button and two general purpose inputs) that can be used anywhere inputs (for example, door contacts, motion sensors, or auxiliary smoke detectors) need to be monitored. When an input becomes active the ZF3 sends the information wirelessly to the coordinator and the monitoring software.
<b>NC-500 Pendant</b>	End Device	The Pendant is a battery powered transmitter with one button. The Pendant is the only mobile device in the network and has an ultrasonic receiver for locating purposes, in addition to ZigBee capabilities.

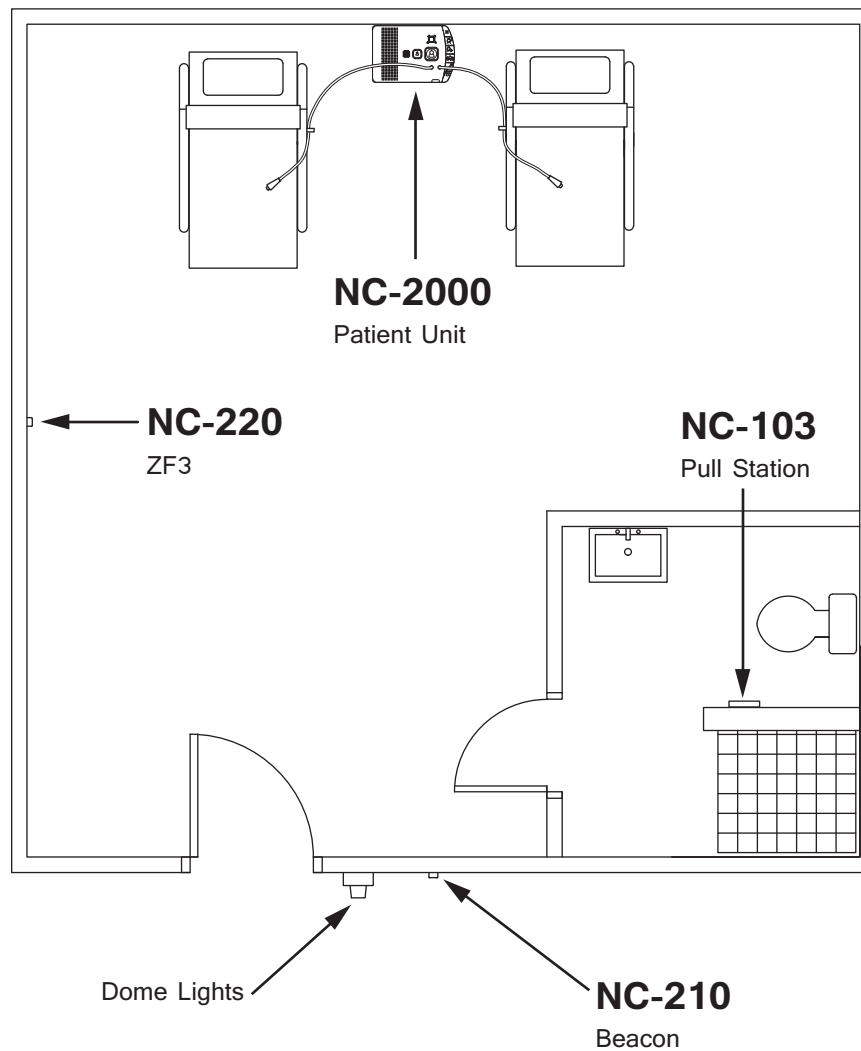
**Figure 1 A two-bed suite with some typical Nurse Call and Emergency System devices installed**

Not shown in Figure 1 is the NC-2100K Coordinator Bundle and the computers running the Dashboard application at the nurse stations.



Coordinators are usually installed in a server room with the Central server.

Each nurse station has a computer with a browser connected to the Dashboard application on the Central server. The Dashboard application shows alerts that are raised by MiCare devices and plays an audible indication to notify nurses of alerts. Speakers **must** be installed on all computers running Dashboard.



**Attention:** In order to comply with UL 2560, the audible signal at the computers must be at least 60 dBA at a distance of one meter. Speakers **MUST** be connected to all computers running Dashboard.

In order to comply with UL 1069, the heartbeat of all the devices must be 1 minute.

This manual contains information on how to install the routers, end devices, and coordinators that make up the Nurse Call and Emergency System.

For information on how to configure the Nurse Call and Emergency System, see LT-2075, the MiCare Nurse Call and Emergency System Administrator's Guide.

For information on how to use the Nurse Call and Emergency System, see LT-2076, the MiCare Nurse Call and Emergency System User Guide.

## 1.2 Contact Us

### 1.2.1 Canada and USA

**Toll Free:** 1-888-660-4655

**Local:** 905-660-4655

**Fax:** 905-660-4113

### 1.2.2 Website

<http://www.mircom.com>

## 2.0 Installing the NC-2100K Coordinator Bundle

The NC-2100K Coordinator Bundle is the heart of the Nurse Call and Emergency System. It passes messages between the routers and the Central server in the Nurse Call and Emergency System. This chapter provides an overview of the Coordinator Bundle and its connections.

**In this chapter you will find the following:**

- Overview
- LEDs
- USB and Power
- Mounting
- Maintenance and Service

## 2.1 Overview



**Install in accordance with the Canadian Electrical Code or the National Electrical Code, and comply with all local regulations. Final acceptance subject to the Local Authority Having Jurisdiction (AHJ).**

There are 2 models of the NC-2100K Coordinator Bundle:

- 1U model
- 2U model

The 2 models differ only in enclosure size, mounting brackets, and position of the LEDs and buttons.

The NC-2100K Coordinator Bundle connects directly to the Central server through USB and is responsible for the communication between the wireless routers and the Central server.

The Coordinator Bundle contains two coordinators. Only one coordinator operates at a time, and the other coordinator is on standby. If one coordinator stops working, the second coordinator takes over.

## 2.2 Dimensions

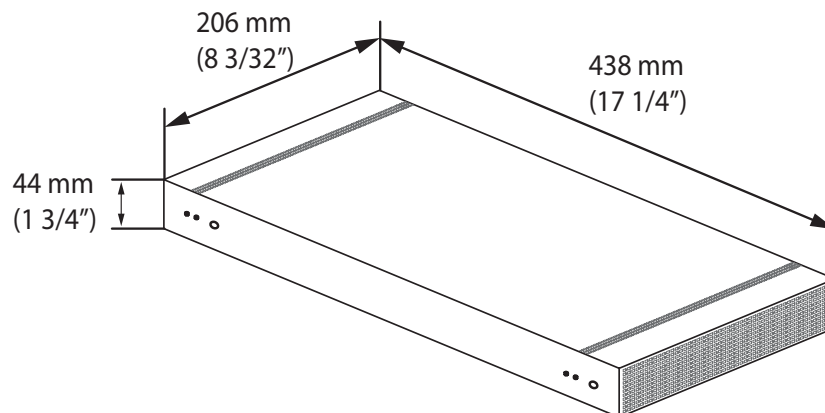

**Figure 2 Dimensions of the NC-2100K Coordinator Bundle (1U model)**

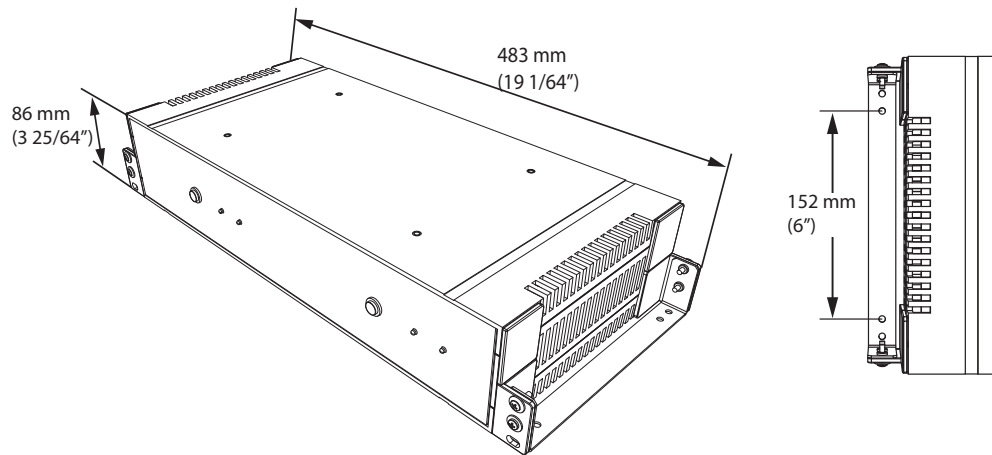

Figure 3 Dimensions of the NC-2100K Coordinator Bundle (2U model)

### 2.3 LEDs

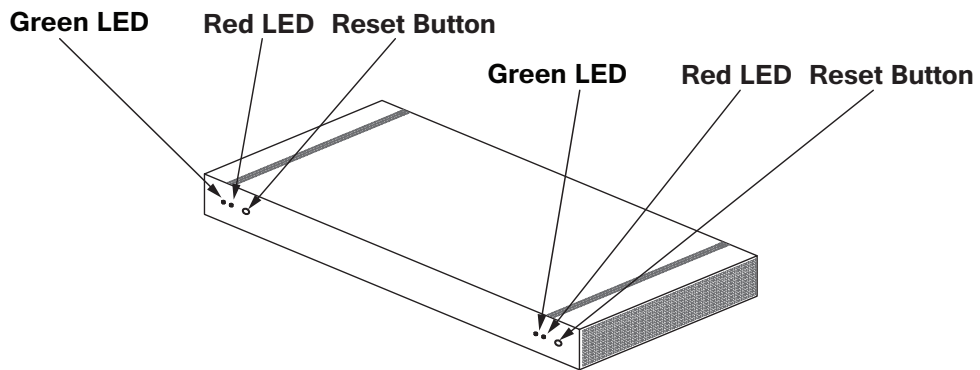
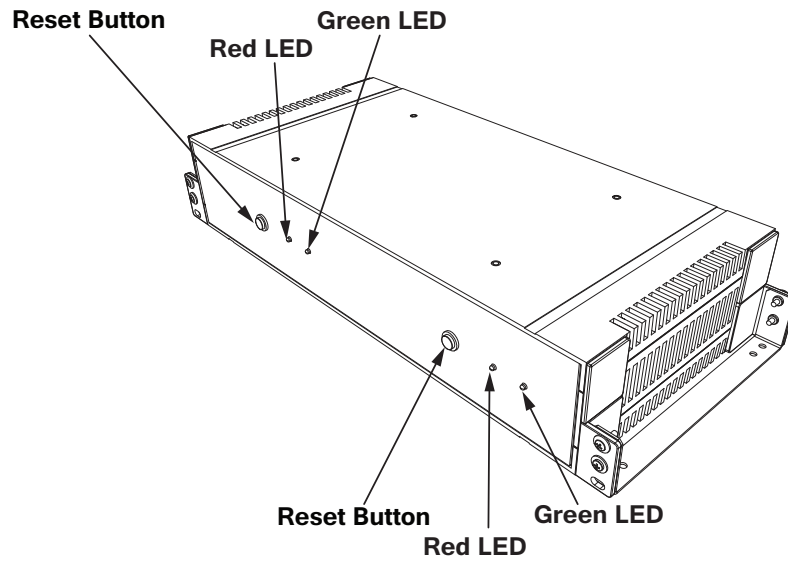

Figure 4 The front of the NC-2100K Coordinator Bundle (1U model)



**Figure 5** The front of the NC-2100K Coordinator Bundle (2U model)

The Coordinator Bundle has two sets of indicators and controls on the front (see Figures 4 and 5).

**Green blinking:** The green LED blinks steadily when its associated coordinator is running. Only one green LED is on at a time.

**Red blinking:** The red LED blinks whenever its associated coordinator transmits or receives messages through USB. Only one red LED is on at a time.

## 2.4 USB and Power

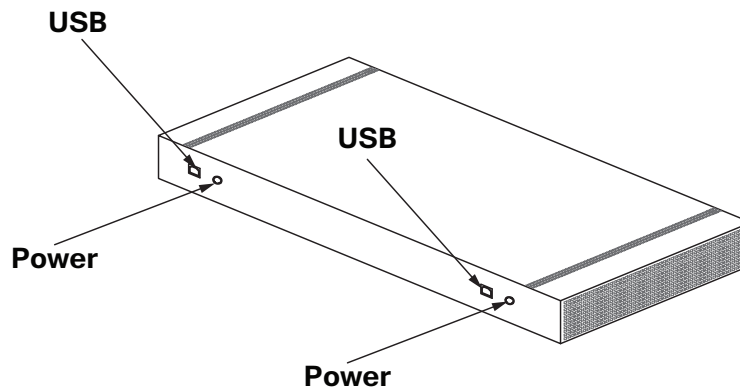

**Figure 6** Location of the USB and power terminals on the back of the NC-2100K Coordinator Bundle (1U model)

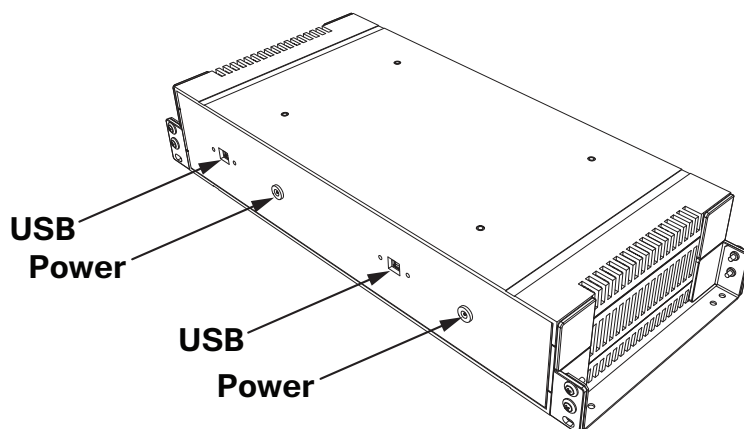

**Figure 7** Location of the USB and power terminals on the back of the NC-2100K Coordinator Bundle (2U model)

### 2.4.1 USB

The Coordinator Bundle connects to the Central server through two USB A to B cables. To connect the Coordinator Bundle to the Central server, attach the supplied USB cables to the USB terminals on the Coordinator Bundle (see Figures 6 and 7) and free USB slots on the Central server.

### 2.4.2 Power

- 2 x Class 2 power supply 24 VDC, 25 mA maximum



**Attention:** In order to comply with UL 2560, you must do the following:

- **Connect the two Class 2 power supplies of the Coordinator Bundle to a power-limited uninterruptible power source (UPS) for back up power. The server and the monitor should be connected to a separate UPS.**
- **Refer to Appendix 2: UL 2560 Requirements for UPS (Uninterruptible Power Supply) for more information about the UPS.**

There are two provided power cables (see Figures 6 and 7). The first time you turn on the Coordinator Bundle, follow these instructions to test it.

#### To power and test the Coordinator Bundle:

1. Attach the provided power cables to the power outlets shown in Figures 6 and 7.
2. Plug the power cables into the power.
3. Confirm that one of the coordinators beeps immediately, and that its green LED starts blinking. This means it has started.
4. Press the reset button (see Figures 4 and 5) for the coordinator with the blinking LED.
5. Confirm that the other coordinator beeps immediately, and that its green LED starts blinking. This means it has started.
6. Wait for 1 minute.

7. Push the reset button for the coordinator with the blinking LED.
8. Confirm that the other coordinator beeps immediately, and that its green LED starts blinking. This means it has started.

## 2.5 Mounting

Both models ship with 2 mounting brackets. Use the brackets to mount the Coordinator Bundle to a wall or wooden shelf. Mount the Coordinator Bundle in a clear open area.



**Figure 8** NC-2100K (1U model) mounted to a wall

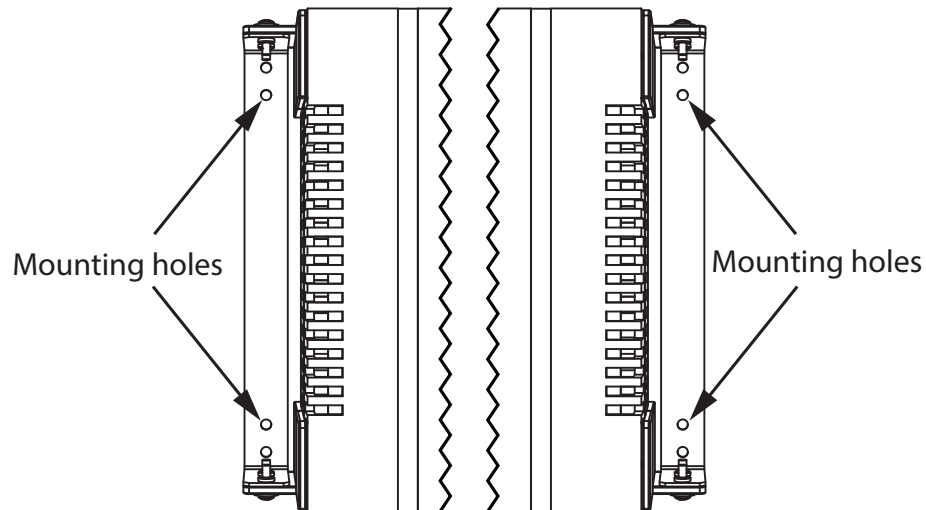

**Figure 9** NC-2100K (2U model) mounting holes

## 2.6 Maintenance and Service

Mircom recommends that each Coordinator Bundle be tested on a weekly basis.

When performing service on a Coordinator Bundle, disconnect the device from the Central server, disconnect the USB cable, and then disconnect it from power before accessing any serviceable areas.

## 3.0 Installing the NC-2000 Patient Unit

The NC-2000 Patient Unit is the backbone of the MiCare Nurse Call and Emergency System wireless network. This chapter provides an overview of the Patient Unit and installation.

**In this chapter you will find the following:**

- Overview
- Telephone Connections
- Inputs
- Dome Lights and Generic Outputs
- Paging Input
- Bed Cords
- Secondary Ultrasound Transmitter
- Power
- Mounting the Patient Unit
- LED Status Indicators
- Maintenance and Service
- Restarting the Patient Unit



### 3.1 Overview



**Install in accordance with the Canadian Electrical Code or the National Electrical Code, and comply with all local regulations. Final acceptance subject to the Local Authority Having Jurisdiction (AHJ).**

The NC-2000 Patient Unit is the backbone of the wireless mesh network that connects all the Nurse Call and Emergency System devices together. End devices (for example, the Pull Station and the ZF3) send messages to the Patient Unit, and the Patient Unit then passes these messages to the NC-2100K Coordinator Bundle and the Nurse Call and Emergency System Central server for processing.

Figure 10 shows the front of the Patient Unit and its features, which include:

- Four LED status indicators
- Speaker and microphone for two-way voice communication with an attendant
- Ultrasound transmitter to locate portable MiCare end devices in the room
- Eight buttons (Code Blue, Emergency, Cancel, Nurse In, Nurse Out, Staff Assist, Maintenance, and Custom Programming)
- Two bed cord jacks

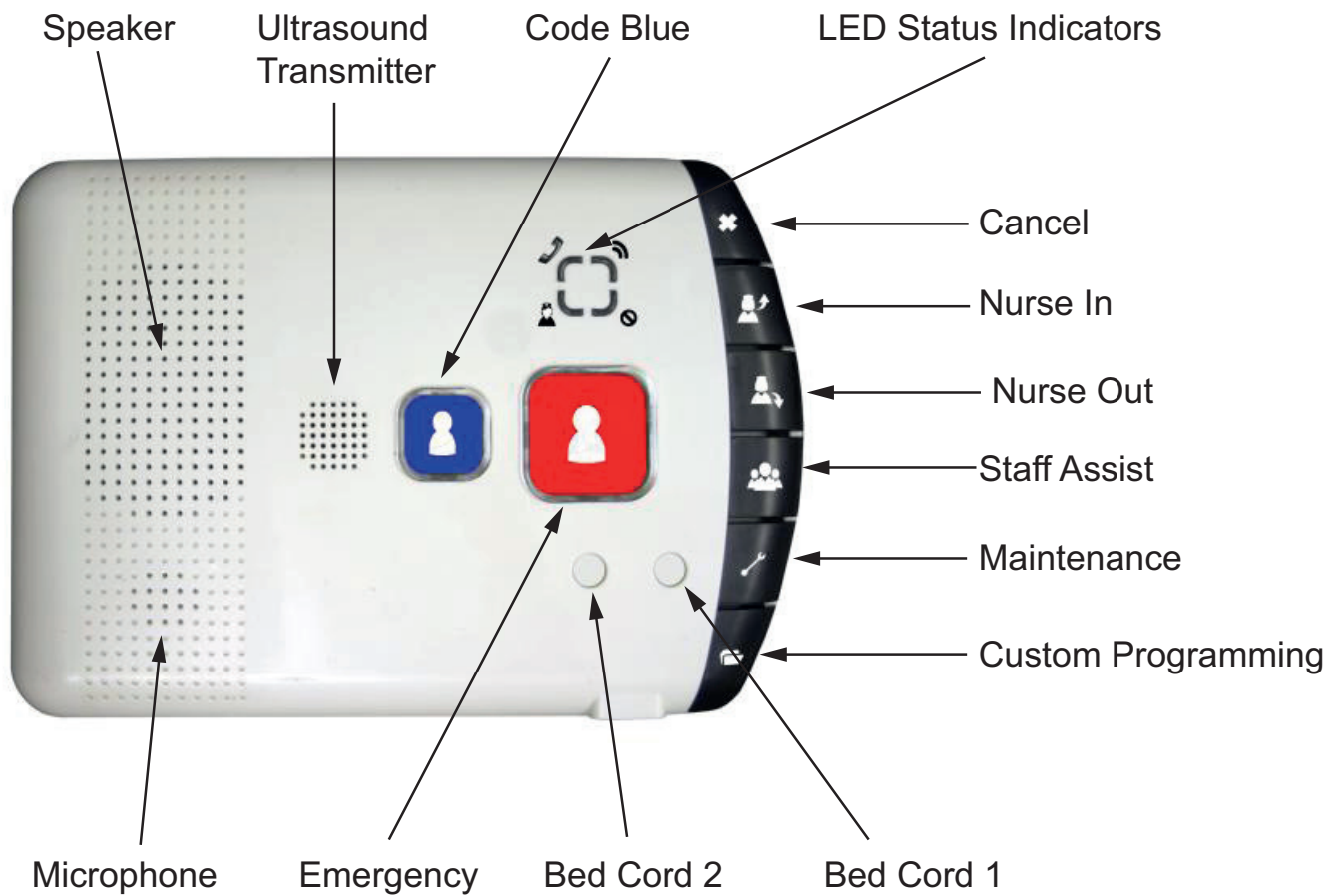

**Figure 10 The front of the NC-2000 Patient Unit**

The back of the Patient Unit has terminals for the following connections:

- Telephone Connections
- Inputs
- Dome Lights and Generic Outputs
- Paging Input
- Secondary Ultrasound Transmitter
- Power

These connections are covered in sections 3.2 to 3.8.

Section 3.9, Mounting the Patient Unit, describes how to mount the Patient Unit to a standard 3 gang PVC box. Note that the Patient Unit is not intended to be used in an Oxygen-Enriched Environment.

Section 3.11, Maintenance and Service, covers the recommended maintenance and service procedures for the Patient Unit.

## 3.2 Telephone Connections

The back of the Patient Unit has two telephone terminals, CN1 and CN2 (see Figure 11). CN1 is the telephone line in, and CN2 goes to the extension(s) in the room.

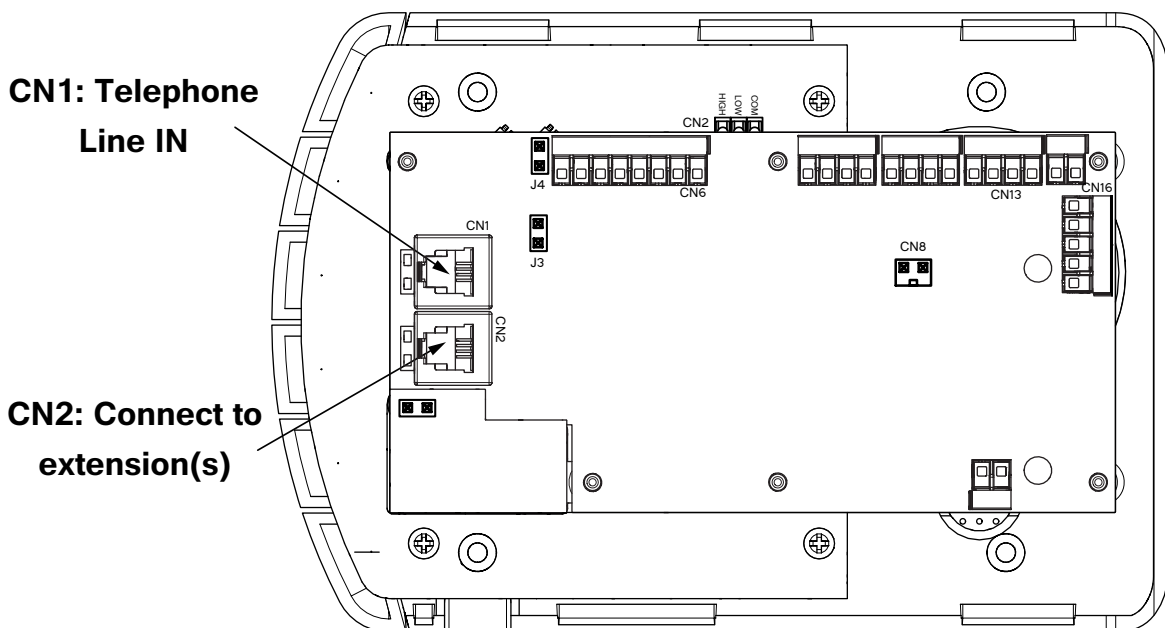

Figure 11 Telephone interface terminals CN1 and CN2



**Note:** Do not overtighten the screw terminals.

There are four pins in each terminal. The two center pins carry the TIP and RING signals for the first extension, and the two outer pins carry the TIP and RING signals for the second extension (if present). Terminals CN1 and CN2 are connected through relays. The relays

break the connection to the extension(s) to allow the Patient Unit to place a call even when an extension is in use.



**Note:** To enable two-way voice communication, see the Globals chapter in LT-2075, the MiCare Nurse Call and Emergency System Administrator's Guide.

CN1 and CN2 take RJ-11 connectors. Table 2 shows the pin connections to make for an RJ-11 connector. Note that the outermost pins (1 and 6) on the RJ-11 are not used.

**Table 2 Pin assignments for an RJ-11 connector**

Pin	Function
1	Not connected
2	TIP for extension 2
3	TIP for extension 1
4	RING for extension 1
5	RING for extension 2
6	No connect

### 3.3 Inputs

Terminal CN6 has four wet contact inputs for call points (with ground returns) on a screw-type terminal block. Inputs should be grounded to their respective ground return through a contact to indicate activity. See Figure 12 for the locations of the four inputs and their ground returns.

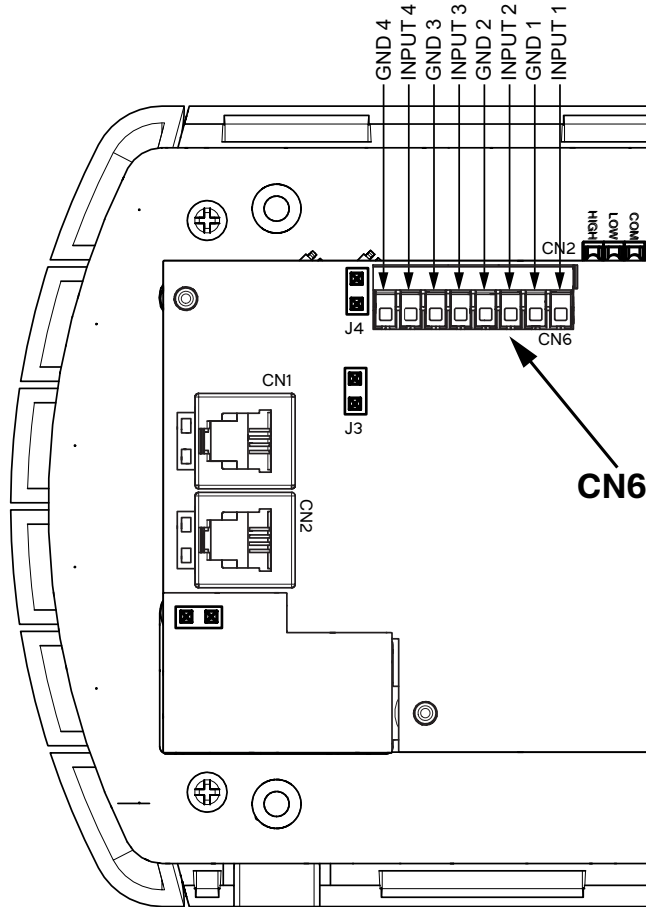

Figure 12 Input connections on CN6



**Note:** Do not overtighten the screw terminals.



**Notes:** The following points regarding the inputs apply:

- Inputs connected to CN6 should be of the normally open type.
- For supervision, connect a 10K ohm resistor across the input.
- Circuits connected to the inputs **must** be limited to a voltage of less than 30V and power less than 100VA in order to comply with UL 1069 and UL 2560.

### 3.4 Dome Lights and Generic Outputs

The Patient Unit supports the following connections for outputs:

- **Dome lights:** there are 4 powered outputs for an external 4-light dome light - see Figure 13. Mircom supplies the NC-4LED Corridor Light. Other dome lights are available through third party manufacturers.
- **Generic outputs:** these are 4 generic dry-contact outputs to activate either normally open or normally closed external devices - see Figure 15



**Note:** The outputs for the dome lights on CN16 are tied to the generic outputs on CN13. If, for example, you activate output 1, output 1 on CN13 and output 1 on CN16 both become active. For information on how to activate outputs, see the Rules chapter in LT-2075, the MiCare Nurse Call and Emergency System Administrator's Guide.

#### 3.4.1 Connecting Third Party Dome Lights

Dome lights connect to terminal CN16, a 5-position screw down block. There are 4 live outputs and a common return for a 5-wire 4-light interface (see Figure 13). These relays are limited to 500 mA maximum each.

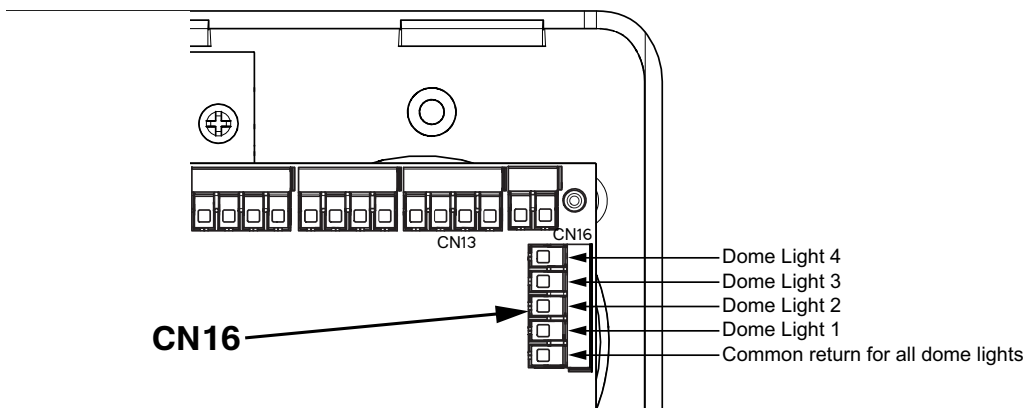

**Figure 13 Dome light connections on terminal CN16**

Wire dome lights by connecting each light to its active output and to the common return.



**Note:** Do not overtighten the screw terminals.



**Note:** Third part dome light manufacturers may use low current LEDs or higher current incandescent lamps. LED dome lights typically range from 5 to 50 mA each, and incandescent lamps typically range from 50 to 250 mA each. The dome light relays (CN16) supply up to 500 mA each. Ensure that the dome lights do not exceed 500 mA each (total of 2.0 A for 4 dome lights).

When calculating the power supply requirements for the Patient Unit, you must include the power requirements for the dome lights.

For example, with four 24 V incandescent light bulbs at 250 mA each, the following input currents are drawn by the Patient Unit (at 24 VDC output):

- Patient Unit maximum current: 25 mA
- 4 dome lights on: 1000 mA

In this example, use a power supply rated at 1.25 A or more.

See section 3.8, Power, on page 27 for more information on power connections.

### 3.4.2 Connecting NC-4LED

The NC-4LED corridor light has six wires.

**Table 3 NC-4LED**

Color	Label	Connect to
Red	R	Output 4 on CN16
Green	G	Output 3 on CN16
Amber	A	Output 2 on CN16
White	W	Output 1 on CN16
Brown	V/G	Common return of dome lights
Blue	L.F.	Not Connected

1. Connect the first 5 wires to terminal CN16, a 5-position screw down block. There are 4 live outputs and a common return for the brown wire (see Figure 14).

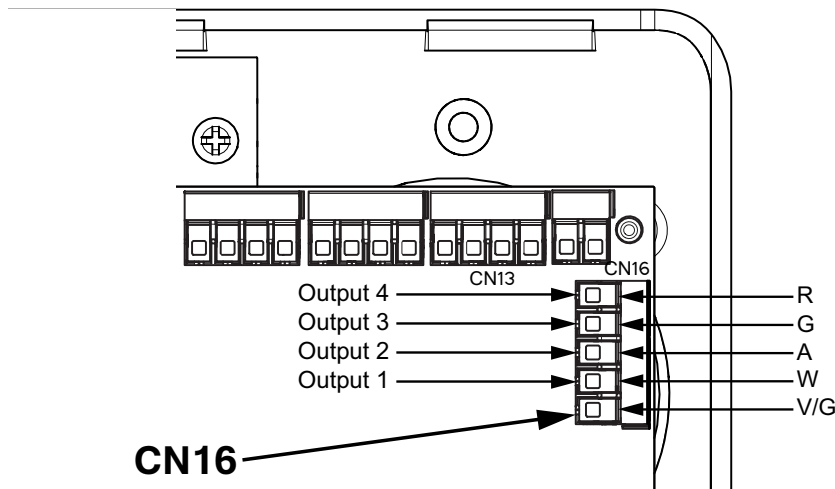

Figure 14 NC-4LED connections on terminal CN16

*i*

**Note:** Do not overtighten the screw terminals.

**NC-4LED electrical ratings:**

- 24 VDC @ 40 mA per LED (total of 160 mA for all 4 LEDs)

*i*

**Note:** When calculating the power requirements for the Patient Unit, you must include the power requirements for the dome lights.

For example, with NC-4LED, the following input currents are drawn by the Patient Unit (at 24 VDC output):

- Patient Unit maximum current: 25 mA
- NC-4LED: 160 mA

In this example, use a power supply rated at 200 mA or more.

**Note:** See section 3.8, Power, on page 27 for more information on power connections.

### 3.4.3 Connecting Generic Outputs

There are four generic dry-contact outputs located on terminal CN13. These outputs can be used to operate a normally open (NO) or normally closed (NC) switch, such as a magnetic door lock. Each output has connections for normally open (NO), normally closed (NC), and common (C) contacts (see Figure 15).

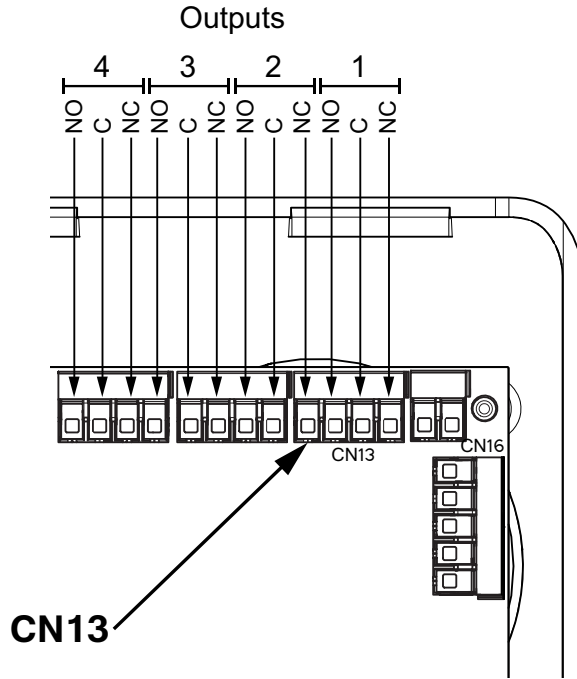

Figure 15 Generic output connections on terminal CN13.



**Note:** Do not overtighten the screw terminals.

The relay contacts for each output are fused with 900mA PTC protection devices to prevent damage from excessive current.



### 3.5 Paging Input

The paging input terminal, CN2, is located on the keypad circuit board below the main circuit board (see Figure 16).

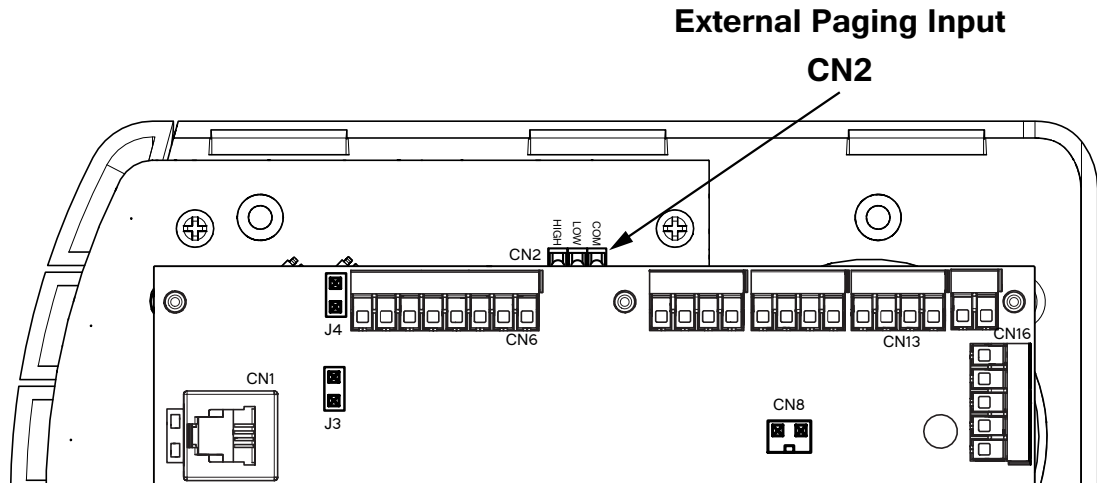

Figure 16 External paging input terminal CN2



**Note:** Do not overtighten the screw terminals.

When connecting to an external paging amplifier, follow these guidelines:

- Use a dedicated pair of 22AWG wires from each Patient Unit to the paging amplifier.
- If your paging amplifier outputs 25 V, connect the outputs on the paging amplifier to the LOW and COM inputs on CN2.

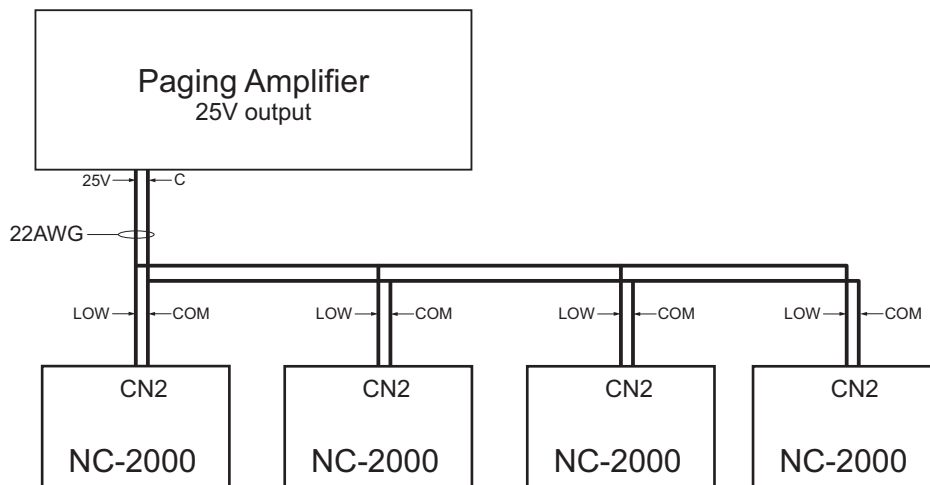

Figure 17 Paging amplifier - 25 V output

- If your paging amplifier outputs 75 V, connect the outputs on the paging amplifier to the HIGH and COM inputs on CN2.

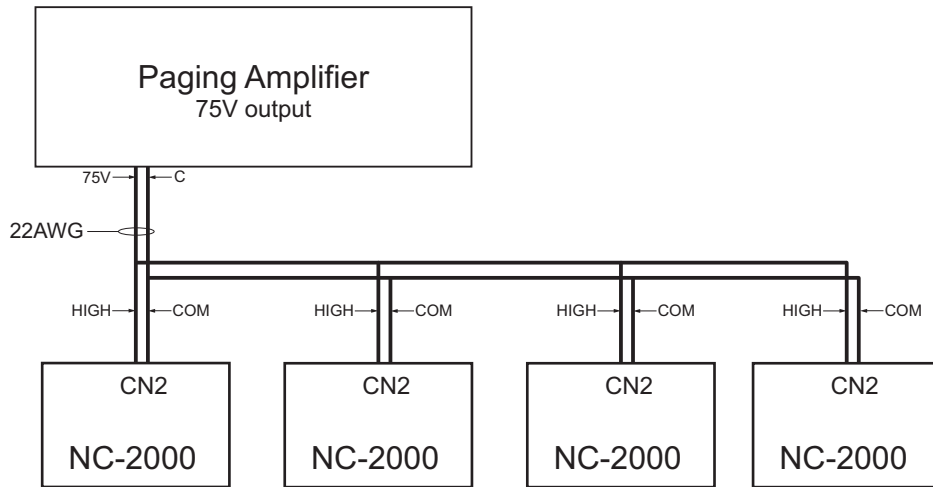

Figure 18 Paging amplifier - 75 V output

### 3.6 Bed Cords

The Patient Unit has two 0.25 inch jacks for bed cords. Each jack is supervised.

- If two bed cords are being used, close the jumper shown in Figure 19.
- If only one bed cord is being used, insert a 0.25 inch dummy plug in the unused jack and close the jumper shown in Figure 19.
- If no bed cords are being used, open the jumper shown in Figure 19.

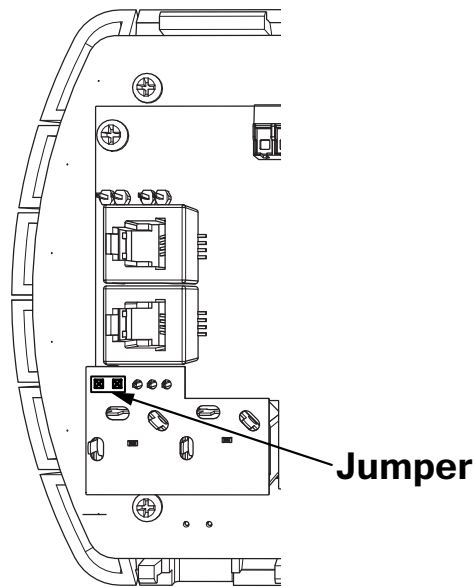

Figure 19 Bed cord input terminal CN3

### 3.7 Secondary Ultrasound Transmitter

Terminal CN14 is used to connect the Patient Unit to a secondary ultrasound transmitter (see Figure 20). The second driver transmitter will have the same ID as the Patient Unit and it can be placed in a separate location from the Patient Unit.

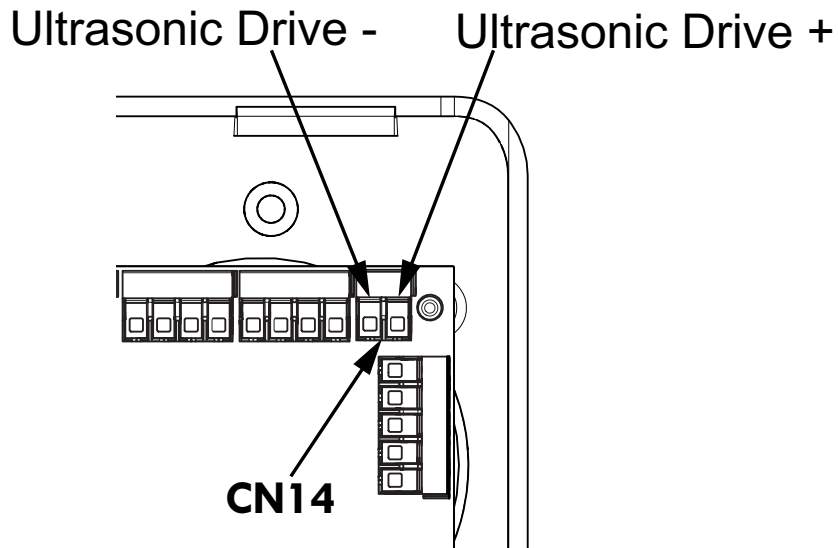

Figure 20 External ultrasonic emitter terminal CN14



**Note:** Do not overtighten the screw terminals.

### 3.8 Power

The Patient Unit requires 24VDC for power. The maximum input current for the Patient Unit is 2.025 A, of which the dome lights are the major contributor. When you are calculating the power supply current requirements for the Patient Unit, you must add the following together:

1. Patient Unit maximum current: 25 mA
2. The maximum current for your dome lights (check with dome light manufacturer). The dome light relays are limited to 2.0 A maximum (4 relays x 500 mA per relay).

The sum of 1 and 2 must not exceed 2.025 A and must be less than the maximum current output of your power supply.



**Notes:** When using the RB-MD-990 power supply to power more than one device, calculate the total amount of current required for all devices connected—Patient Units along with their dome lights—so as not to exceed the power output of the power supply or the power ratings for any connectors.



**Attention:** In order to comply with UL 2560, you must do the following:

- Connect all Class 2 power supplies for the Patient Units to a power-limited uninterruptible power source (UPS) for back up power.
- Refer to Appendix 2: UL 2560 Requirements for UPS (Uninterruptible Power Supply) for more information about the UPS.

### 3.8.1 Connecting Power

The power connection terminal is CN11, a screw-type terminal block (see Figure 21).

#### J3 and J4

Open

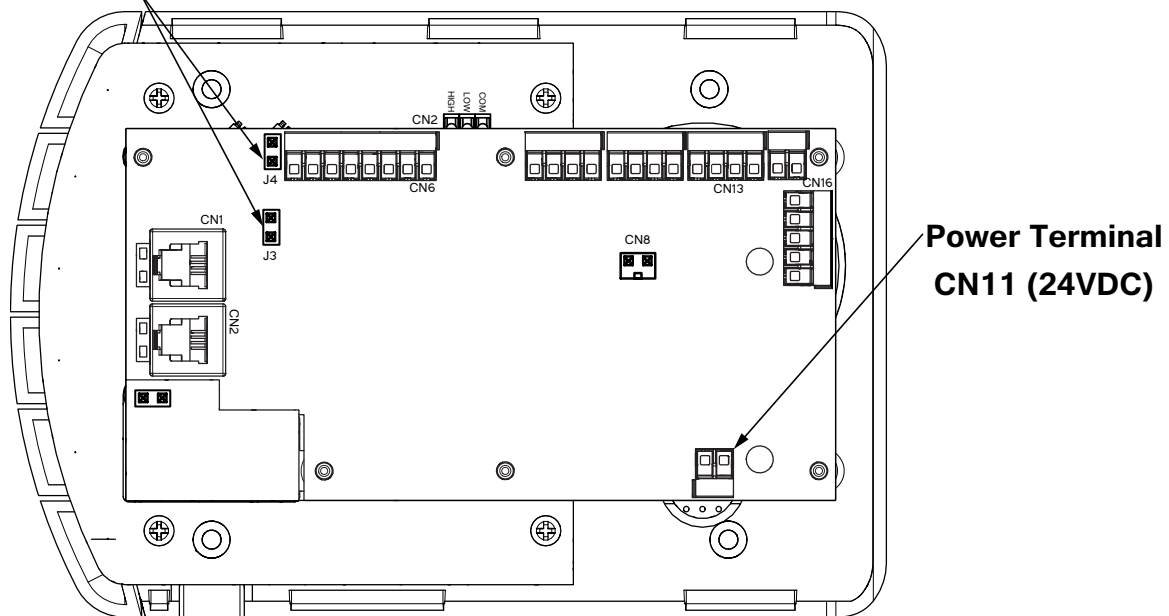

**Figure 21** Power terminal CN11 and jumpers J3 and J4



**Note:** Do not overtighten the screw terminals.

#### To power the Patient Unit:

1. Attach the wires from your power supply to CN11.  
The inputs are polarity independent. There should be no exposed wire present. The screws must be set securely enough so that the wires cannot come loose.
2. If there are jumpers on J3 or J4, remove them.

### 3.8.2 Optional Battery

A rechargeable nickel-cadmium battery (part number NC-PBAT) can be purchased from Mircom to provide standalone power for the Patient Unit. The battery connects to the battery terminal CN8 (see Figure 22). To secure the battery, loop a cable tie through the two holes in the circuit board and then tighten it around the battery.

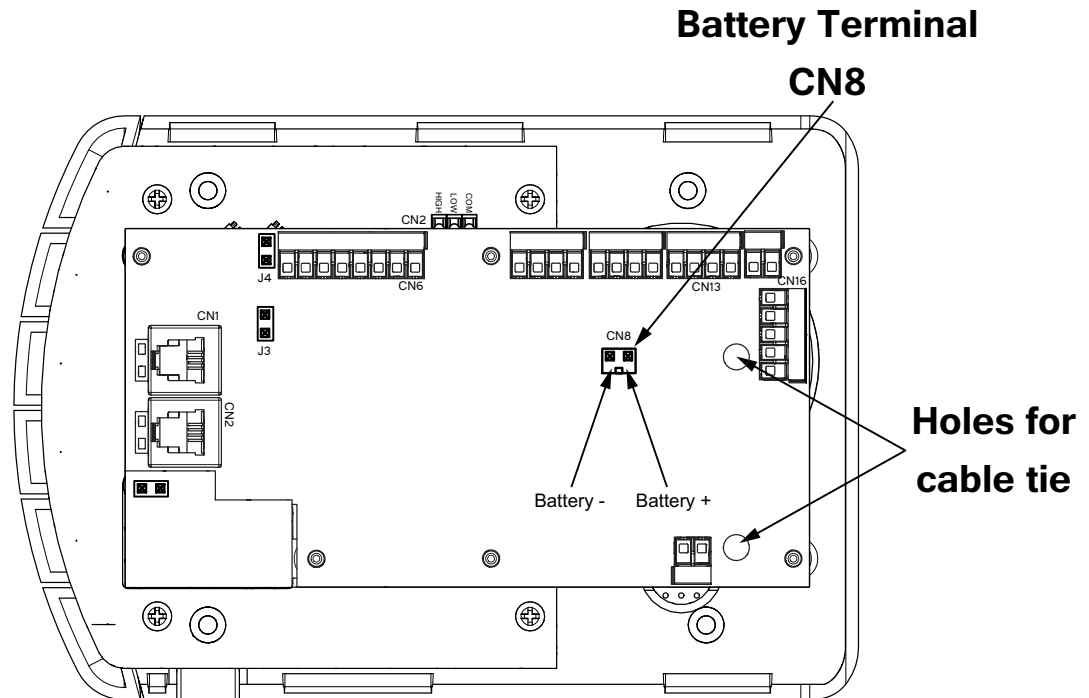

Figure 22 Battery terminal CN8



**Note:** Do not overtighten the screw terminals.



**Attention:** The battery alone does not meet the requirements for UL 2560 because it does not power the dome lights. In order to comply with these standards, connect the Class 2 power source for the Patient Unit to a power-limited uninterruptible power source (UPS).

### 3.9 Mounting the Patient Unit

The Patient Unit mounts on the supplied mounting plate, which attaches to a standard 3 gang PVC box. Note that the Patient Unit is not intended to be used in an Oxygen-Enriched Environment.



**Note:** Prior to mounting the Patient Unit, record its MAC address and location (building, wing, floor, and room). This information is needed to add the Patient Unit to the MiCare Central server. Appendix 5: Device Installation Table on page 59 has an example device installation table that you can use to record this information.

**To mount the Patient Unit:**

1. Attach the mounting plate to the 3 gang PVC box using four screws (see Figure 23).

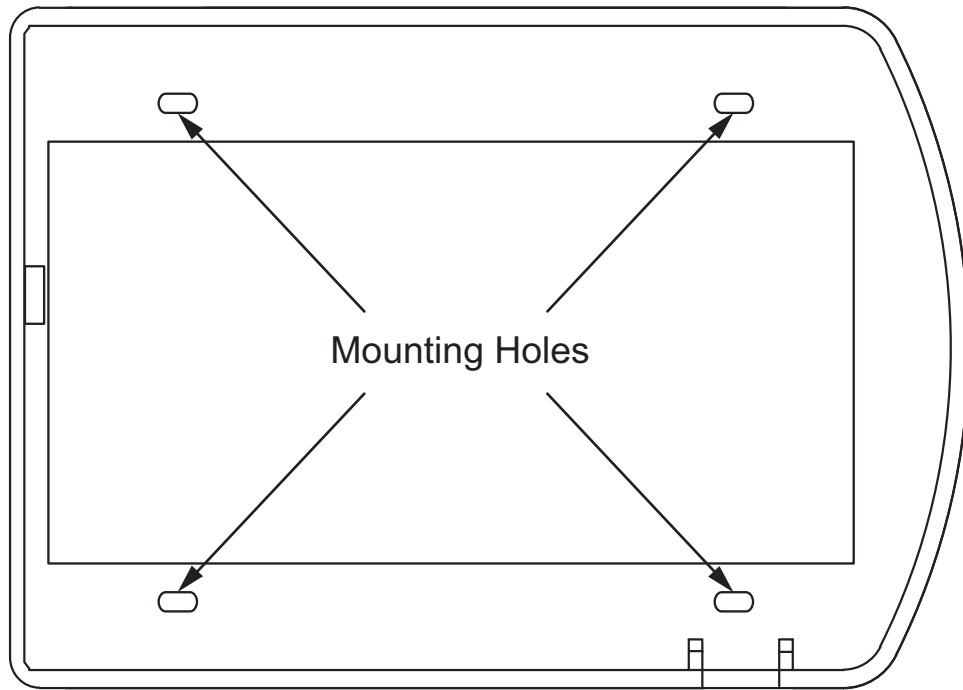





**Figure 23 Patient Unit mounting plate**

2. Attach the Patient Unit to the mounting plate.

### 3.10 LED Status Indicators

**Table 4 Patient Unit LED Status Indicators**

LED	Function
 <b>Top Left</b>	<p><b>Off:</b> The phone line is not enabled.</p> <p><b>Red blinking:</b> The phone line is enabled but no phone is connected.</p> <p><b>Steady green:</b> A phone is connected.</p>
 <b>Top Right</b>	<p><b>Red blinking:</b> The Code Blue, Emergency, Staff Assist, Maintenance or Custom Programming buttons are pressed.</p>
 <b>Bottom Left</b>	<p><b>Green Blinking:</b> The Patient Unit has not joined the network.</p> <p><b>Steady green:</b> The Nurse In button is pressed.</p> <p><b>Red blinking for 10 seconds:</b> The Nurse Out button is pressed.</p>
 <b>Bottom Right</b>	<p><b>Steady red:</b> There is a fault, for instance when the unit loses its custom settings.</p>

### 3.11 Maintenance and Service

Mircom recommends that each Patient Unit be tested on a weekly basis.

When performing service on a Patient Unit, disconnect power and all connections (inputs and outputs) going to the unit before accessing any serviceable areas.

### 3.12 Restarting the Patient Unit

#### To restart the Patient Unit

- Press the **Cancel** and **Nurse Out** buttons at the same time.

#### To reset the Patient Unit to factory default settings

- Press the **Cancel** and **Staff Assist** buttons at the same time.

For information on the default settings, see LT-2075 MiCare Administrator's Guide.

## 4.0 Installing the NC-210/NC-211 Beacon

The MiCare Beacon provides a fast and easy way to extend the Nurse Call and Emergency System. This chapter provides an overview of the Beacon and how to install it.

**In this chapter you will find the following:**

- Overview
- NC-210
- NC-211
- Installing the Beacon
- Maintenance and Service



## 4.1 Overview



**Install in accordance with the Canadian Electrical Code or the National Electrical Code, and comply with all local regulations. Final acceptance subject to the Local Authority Having Jurisdiction (AHJ).**

The MiCare Beacon has all of the message routing functionality of the NC-2000 Patient Unit. That is, the Beacon communicates with end devices on the network and passes messages from the end devices to the Nurse Call and Emergency System Central server for processing. The Beacon can be used in conjunction with a Patient Unit (for example, to extend the Patient Unit's range in a large room) or as a stand alone router.

There are two models of the Beacon.

- NC-210
- NC-211

## 4.2 NC-210

Figure 24 shows the front of the NC-210 Beacon and its features, which include:

- Security screw
- LED status indicator
- Ultrasound transmitter

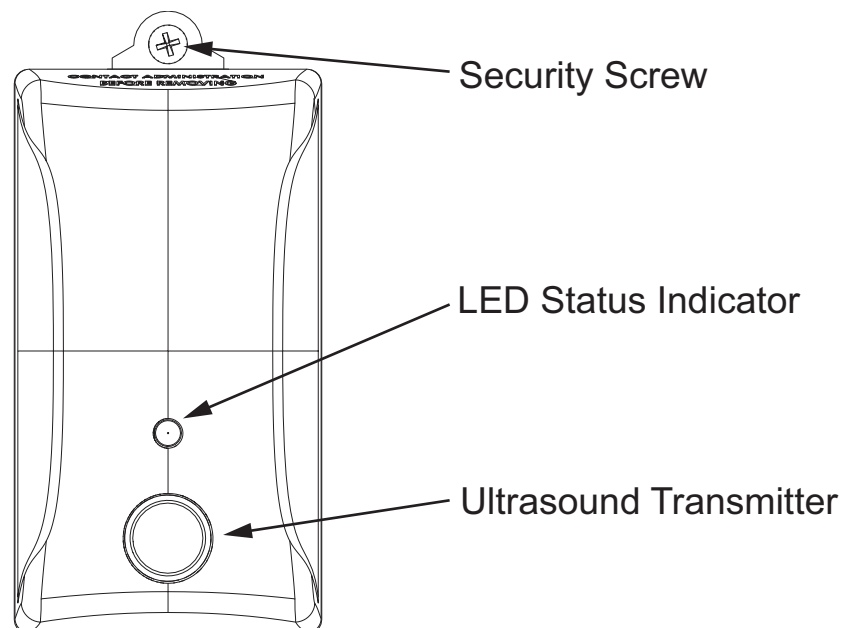

**Figure 24** The front of the NC-210 Beacon

### 4.2.1 LED Status Indicator on NC-210

**Green blinking:** The Beacon has not joined a network.

**Steady green:** The Beacon has joined a network.

## 4.3 NC-211

Figure 25 shows the front of the NC-211 Beacon and its features, which include:

- Security screw
- LED status indicators
- Ultrasound transmitter

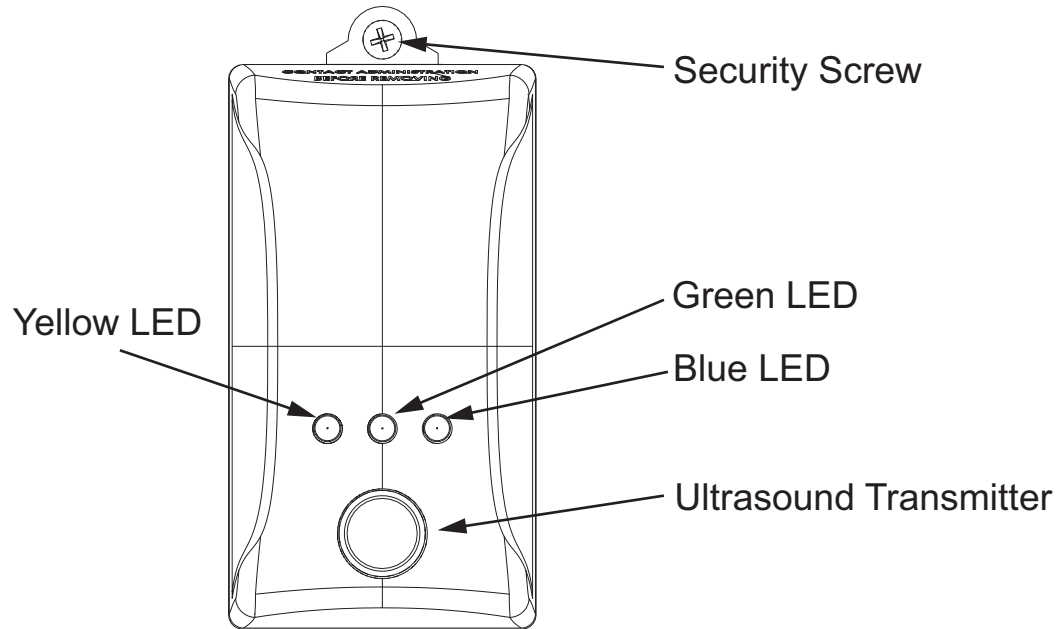

**Figure 25** The front of the NC-211 Beacon

### 4.3.1 LED Status Indicators on NC-211

**Steady yellow:** The Beacon is powered by AC.

**Green blinking:** The Beacon has not joined a network.

**Steady green:** The Beacon has joined a network.

**Steady blue:** The Beacon's battery is charging.

**Blue blinking:** The battery has stopped charging because of a problem. See section "Troubleshooting the NC-211 Battery" on page 36.

**Blue off:** The battery is charged.

When the beacon is in normal operation, then the yellow and green LEDs are on steady and the blue LED is off.

### 4.3.2 NC-211 Battery

The NC-211 Beacon contains a battery for supplementary operation. It is not a secondary source of power.



**Attention:** In order to comply with UL 2560, connect all power supplies for the Beacons to a power-limited uninterruptible power source (UPS) for back up power. The UPS will report AC loss troubles.

Refer to Appendix 2: UL 2560 Requirements for UPS (Uninterruptible Power Supply) for more information about the UPS.

### 4.3.3 Before Installing NC-211 for the First Time

Before you install NC-211, you must activate the battery.

**To activate the NC-211 battery:**

1. Open the enclosure by removing the 4 screws and removing the back cover.

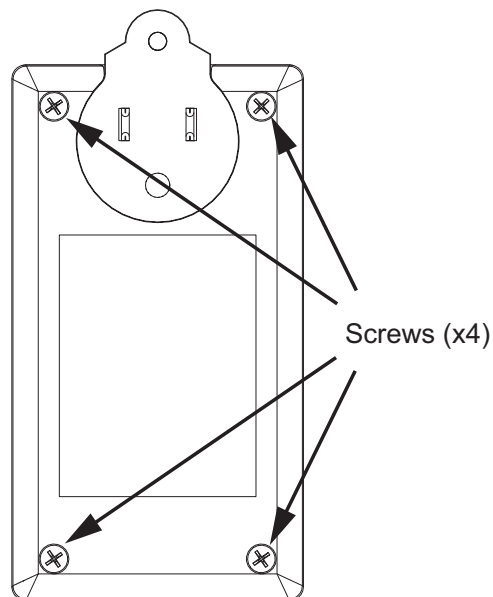

**Figure 26** NC-211 (back view)

2. Close jumper JW1.

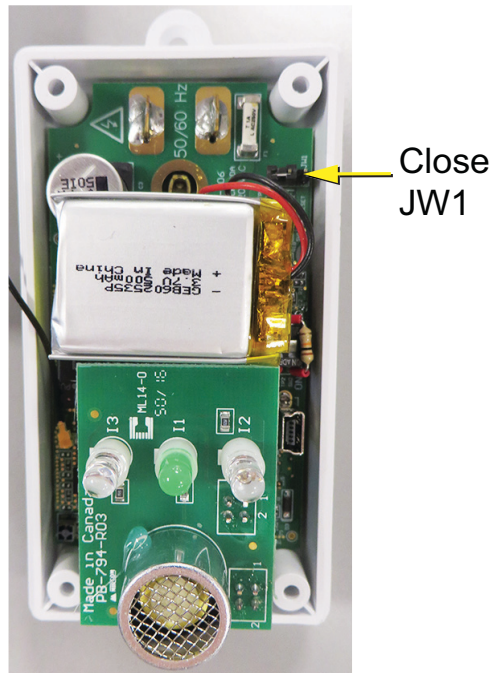

**Figure 27 JW1 on NC-211**

3. Attach the back cover and secure it with the 4 screws.

### Troubleshooting the NC-211 Battery

If the blue (rightmost) LED blinks, it means that the battery has stopped charging.

- Unplug the beacon, wait for 1 minute, and then plug the beacon back into the wall.
- If the blue LED continues to blink, then contact Mircom customer service.

### 4.3.4 Audible Low Battery Indication

The NC-211 beeps when there is no AC power and the battery is low. When AC power is restored, the battery starts charging and the beeping stops.

## 4.4 Installing the Beacon

Both models of Beacon plug into a standard three prong 120 VAC electrical outlet. Refer to Appendix 1: Specifications for the Beacons' electrical ratings. It is recommended that some form of back up power be used. Note that the Beacon is not intended to be used in an Oxygen-Enriched Environment.



**Attention:** In order to comply with UL 2560, perform all of the following tasks:

- Connect all power supplies for the Beacons to a power-limited uninterruptible power source (UPS) for back up power.
- Refer to Appendix 2: UL 2560 Requirements for UPS (Uninterruptible Power Supply) for more information about the UPS.



**Note:** Prior to mounting the Beacon, record its MAC address and location (building, wing, floor, and room). This information is needed to add the Beacon to the MiCare Central server. Appendix 5: Device Installation Table on page 59 has an example device installation table that you can use to record this information.

### To install the Beacon:

- Plug the Beacon into a standard 120 VAC three-pronged outlet.



**Attention:** If your installation must comply with UL 1069 or CSA No. 205, note the following:

- In order to comply with UL 1069, do not install the Beacon in a patient care vicinity area. Secure the Beacon to the wall with the security screw. The receptacle must be standard (with a screw in the middle), and not a designer or decorative receptacle. Plug the Beacon into the bottom outlet, and secure it with the security screw through the hole in the middle of the receptacle.
- In order to comply with CSA No. 205, do not install the security screw with the Beacon.

## 4.5 Maintenance and Service

Mircom recommends that each Beacon be tested on a weekly basis.

When performing service on a Beacon, disconnect it from power before accessing any serviceable areas.

## 5.0 Installing the NC-103 Pull Station

The NC-103 Pull Station is a fully stand alone end device that communicates with the routers (Patient Units and Beacons) in the Nurse Call and Emergency System. This chapter provides an overview of the Pull Station and its connections.

**In this chapter you will find the following:**

- Overview
- Input
- Power
- Mounting the Pull Station
- LED Status Indicator and Beeper
- Maintenance and Service

## 5.1 Overview



**Install in accordance with the Canadian Electrical Code or the National Electrical Code, and comply with all local regulations. Final acceptance subject to the Local Authority Having Jurisdiction (AHJ).**

The NC-103 Pull Station is an end device in the MiCare Nurse Call and Emergency System. The Pull Station communicates wirelessly with the routers (Patient Units or Beacons) in the Nurse Call and Emergency System.

Figure 28 shows the front of the Pull Station and its features, which include:

- Emergency button
- LED status indicator
- Staff Assist button
- Cancel button
- Pull cord (emergency)

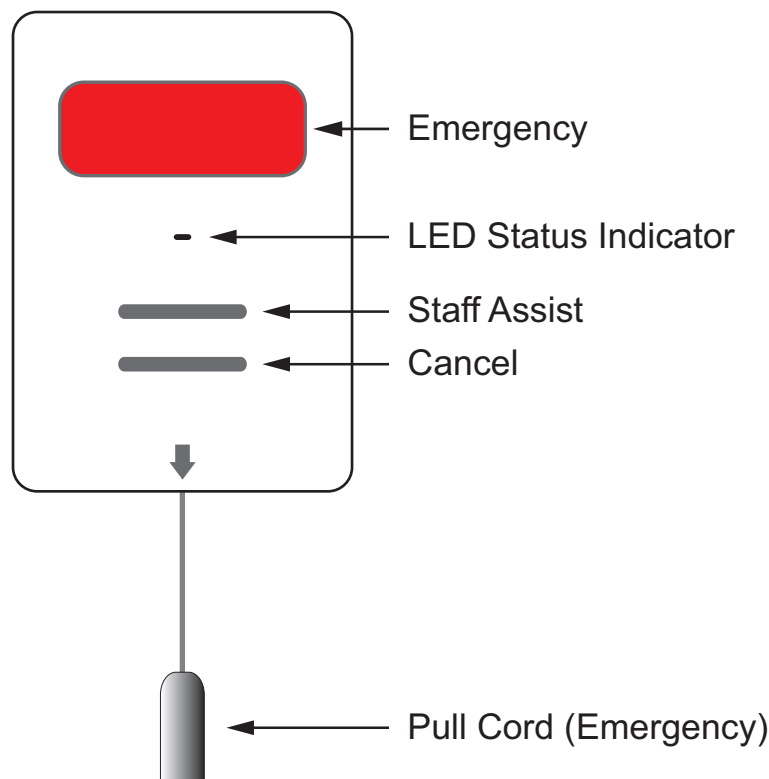

**Figure 28 The front of the NC-103 Pull Station**

The Pull Station has terminals for the following connections:

- Input
- Power

These connections are covered in sections 5.2 and 5.3.

Section 5.4, Mounting the Pull Station, describes how to mount the Pull Station to a single gang PVC box. Note that the Pull Station is not intended to be used in an Oxygen-Enriched Environment.

Section 5.6, Maintenance and Service, covers the recommended maintenance and service procedures for the Pull Station.

## 5.2 Input

The Pull Station can monitor the state of a normally open input. When the input becomes active, the Pull Station reports this to Nurse Call and Emergency System Central server. Examples of inputs include a door contact or a flood detector.

The operating specifications for the input on the Pull Station are:

- Wet contact pair, supplied voltage is max 3.6 V
- Nominal current of 1.4 mA (external loop closed)
- Maximum current 5 mA

To connect an input, attach the positive and negative wires from the input to the positive (+) and negative (-) terminals on TS1 (located on the back of the Pull Station).

## 5.3 Power

To power the Pull Station, insert two standard AA batteries in the battery terminals located on the back of the Pull Station.

## 5.4 Mounting the Pull Station

The Pull Station mounts on the supplied mounting plate, which attaches to a standard single gang PVC box. Note that the Pull Station is not intended to be used in an Oxygen-Enriched Environment.



**Note:** Prior to mounting the Pull Station, record its MAC address and location (building, wing, floor, and room). This information is needed to add the Pull Station to the MiCare Central server. Appendix 5: Device Installation Table on page 59 has an example device installation table that you can use to record this information.



**Attention:** The Pull Station is not to be installed in a shower stall or in an equivalent location where water spray would be encountered.



**To mount the Pull Station:**

1. If you are connecting an input to the Pull Station, run the wires for the input to the single gang PVC box and then through the wiring hole on the mounting plate (see Figure 29).
2. Attach the mounting plate to the single gang PVC box using two screws (see Figure 29).

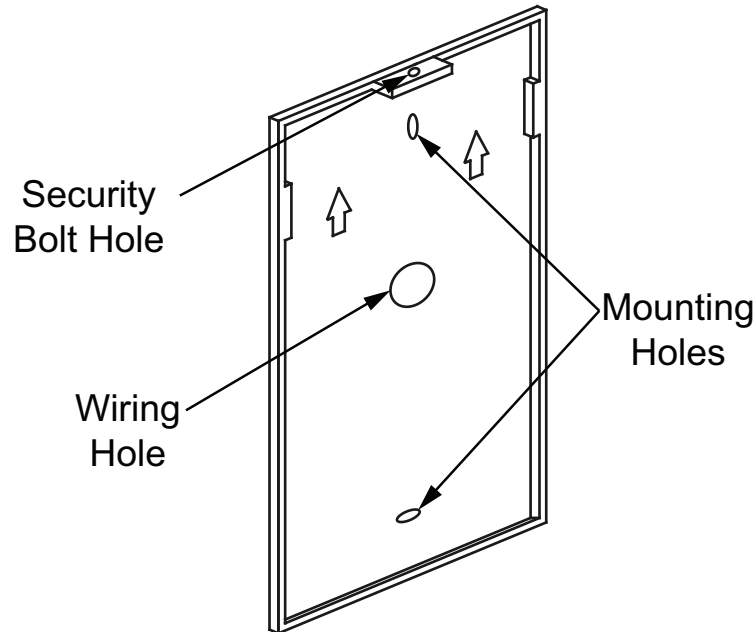

**Figure 29 Pull Station mounting plate**

3. Attach the Pull Station to the mounting plate.
4. Fasten the Pull Station to the mounting plate with a security bolt.

## 5.5 LED Status Indicator and Beeper

**Medium green blinking:** The Pull Station has not joined the network.

**Slow green blinking:** The Pull Station is sending a message.

**One red blink:** The current operation has failed.

The Pull Station uses two methods to send a message: it first sends a unicast message, and then a broadcast message if the unicast message fails.

1. **Unicast:** the Pull Station waits to receive a confirmation from the Nurse Call and Emergency System Central server that the message was received. The LED blinks red once if the Pull Station does not receive a reply.
2. **Broadcast:** the Pull Station does not wait to receive a reply. This means that if the broadcast message fails, the LED does not blink red. It simply blinks slow green during the broadcast message, and then stops.

**Beep:** The Pull Station beeps when the Emergency button is pressed, when the Pull Station has found a network, and when the Pull Station receives a reply.

## 5.6 Maintenance and Service

Mircom recommends that each Pull Station be tested on a weekly basis.

When performing service on a Pull Station, remove its batteries and then disconnect any input connections before accessing any serviceable areas.

## 6.0 Installing the NC-220 ZF3

The NC-220 ZF3 is a fully stand alone end device that communicates with the routers (Patient Units and Beacons) in the Nurse Call and Emergency System. This chapter provides an overview of the ZF3 and its connections.



**Note:** The ZF3 is an auxiliary device for supplementary operation.

### In this chapter you will find the following:

- Overview
- Inputs
- Power
- Mounting the ZF3
- Maintenance and Service

## 6.1 Overview



**Install in accordance with the Canadian Electrical Code or the National Electrical Code, and comply with all local regulations. Final acceptance subject to the Local Authority Having Jurisdiction (AHJ).**

The NC-220 ZF3 is an end device in the MiCare Nurse Call and Emergency System. The ZF3 monitors up to 3 inputs (one for cancel button and two general purpose inputs) and communicates wirelessly with the routers (Patient Units or Beacons) in the Nurse Call and Emergency System.

The ZF3 has terminals for the following connections:

- 3 Inputs
- Power

These connections are covered in sections 6.2 and 6.3.

Section 6.4, Mounting the ZF3, describes how to mount the ZF3. Note that the ZF3 is not intended to be used in an Oxygen-Enriched Environment.

Section 6.5, Maintenance and Service, covers the recommended maintenance and service procedures for the ZF3.

## 6.2 Inputs

The ZF3 can monitor the state of up to 3 normally open inputs (one cancel button and two generic inputs). When an input becomes active, the ZF3 sends a notification to the 802.15.4 wireless network. This notification is then picked up by one of the routers in the Nurse Call and Emergency System, which then sends it to the Central server for processing. Examples of general purpose inputs that can be used with the ZF3 include auxiliary smoke detectors, door contacts, cancel buttons, and motion sensors.

The operating specifications for the inputs on the ZF3 are:

- Wet contact pair, supplied voltage is max 3.6 V
- Nominal current of 1.4 mA (external loop closed) and an absolute maximum of 5 mA

The input terminals for the ZF3 are TS1 (cancel button) and TS2 (2 generic inputs). They are located on the ZF3 circuit board (see Figure 30). To connect an input, attach the positive and negative wires from the input to the input and ground terminals on either TS1 or TS2.

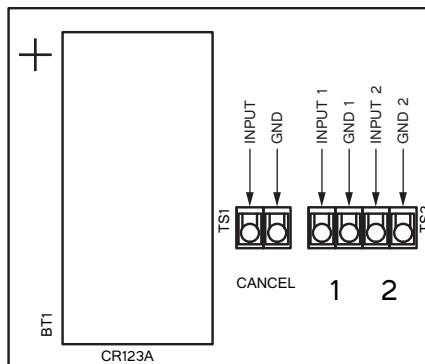

**Figure 30** Input terminals TS1 and TS2 on the NC-220 ZF3.

### 6.3 Power

To power the ZF3, insert a CR123A battery in the battery terminal, BT1, located on the ZF3 circuit board (see Figure 30).

### 6.4 Mounting the ZF3

The ZF3 mounts on a wall using four screws. After mounting the ZF3, attach the cover plate to the unit.

Note that the ZF3 is not intended to be used in an Oxygen-Enriched Environment.



**Note:** Prior to mounting the ZF3, record its MAC address and location (building, wing, floor, and room). This information is needed to add the ZF3 to the MiCare Central server. Appendix 5: Device Installation Table on page 59 has an example device installation table that you can use to record this information.



**Attention:** The ZF3 is not to be installed in a shower stall or in an equivalent location where water spray would be encountered.

### 6.5 Maintenance and Service

Mircom recommends that each ZF3 be tested on a weekly basis.

When performing service on a ZF3, remove its battery and then disconnect any input connections before accessing any serviceable areas.

## 7.0 Installing The NC-500 Pendant

The MiCare NC-500 Pendant provides a fast and easy way to extend the Nurse Call and Emergency System. This chapter provides an overview of the Pendant and how to install it.

**In this chapter you will find the following:**

- Overview
- LED Status Indicator
- Using the Pendant
- Maintenance and Service

## 7.1 Overview

A patient wears the Pendant on a lanyard around the neck. If the patient needs assistance, he or she presses the button, and the Pendant sends a message to the Nurse Call and Emergency System Central server.

Figure 31 shows the front of the Pendant and its features, which include:

- Flexible outer cover
- Button
- Ultrasound receiver
- LED Indicator

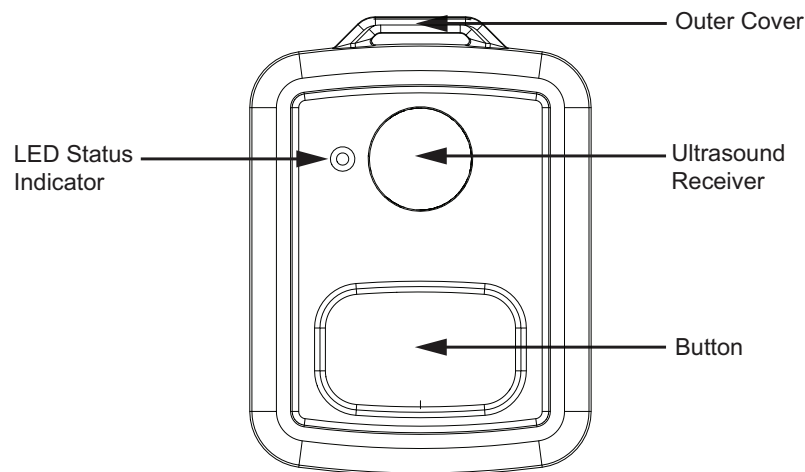

Figure 31 The front of the NC-500 Pendant

## 7.2 LED Status Indicator

**Fast green blinking:** The Pendant is looking for an ultrasound device.

**Medium green blinking:** The Pendant is sending a message over the network.

**Slow green blinking:** The Pendant is waiting for a response to the message.

**One red blink:** The current operation has failed.

Fast green blinking followed by a red blink means that the Pendant failed to find an ultrasound device. Even if the Pendant cannot find an ultrasound device, it will still send the message.

The Pendant uses two methods to send a message: it first sends a unicast message, and then a broadcast message if the unicast message fails.

1. Unicast: the Pendant waits to receive a confirmation from the Nurse Call and Emergency System Central server that the message was received. The LED blinks red once if the Pendant does not receive a reply.
2. Broadcast: the Pendant does not wait to receive a reply. This means that if the broadcast message fails, the LED does not blink red. It simply blinks slow green during the broadcast message, and then stops.

## 7.3 Using the Pendant

### To use the Pendant:

1. To call for assistance, press the button.

The LED blinks green to indicate that the Pendant is sending a message to the Nurse Call and Emergency System Central server.

## 7.4 Canceling the Message from the Pendant

### To cancel the message from the Pendant:

1. Wave a magnet over the Pendant.

The message disappears from the Nurse Call and Emergency System Central server.

## 7.5 Maintenance and Service

The Pendant uses one CR2450 battery. The estimated battery life is one year.

### To replace the battery:

1. Remove the flexible outer cover.
2. Hold the pendant so that the button is facing down.
3. Insert a small screwdriver into the indentation between the bottom and top halves of the case and turn to open the case.

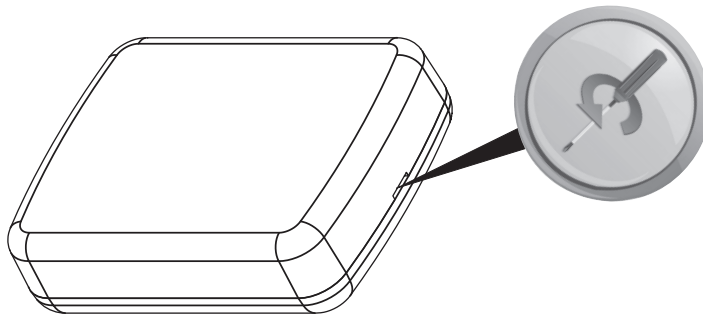

**Figure 32** Use a small screwdriver to open the case



4. Carefully remove the circuit board from the case.  
The battery holder is on top of the circuit board (Figure 33).

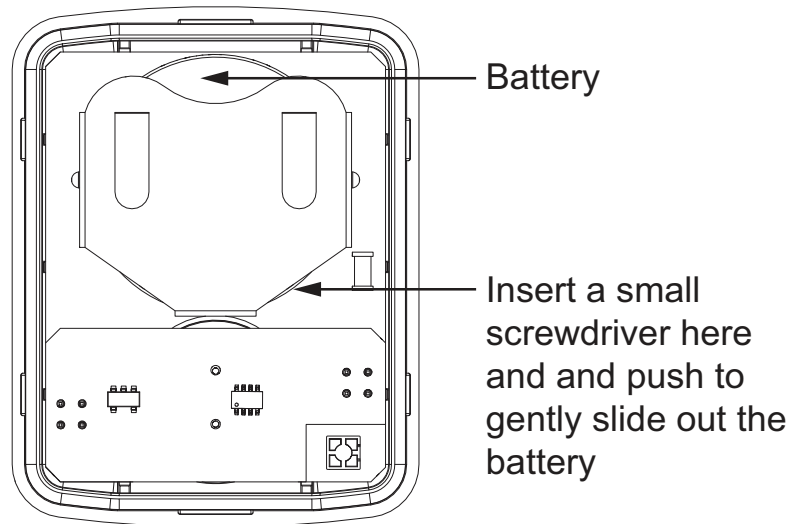

**Figure 33** Pendant with bottom half of case removed

5. Insert a small screwdriver as shown in Figure 33 and push to gently slide out the battery.



**Attention:** To prevent damage to the circuit boards, always hold them by the edges.  
Avoid touching the screwdriver to the circuit board components.

6. Insert the replacement battery with the positive side facing up.
7. Place the circuit board in the top half of the case so that the ultrasound receiver fits in the hole.
8. Snap the two halves of the case together.
9. Replace the flexible outer cover so that the pendant shows through the larger hole.



**Note:** There are holes on both sides of the flexible outer cover. Put the cover on the pendant so that the front of the pendant shows through the larger hole.

Mircom recommends that each Pendant be tested on a weekly basis.

When performing service on a Pendant, disconnect it from power before accessing any serviceable areas

## 8.0 Appendix 1: Specifications

### 8.1 NC-2000 Patient Unit

<b>Standards:</b>	UL 1069, 2560, CSA 22.2 #205, FCC Part 15/Part 68, Class “B”, CS-03
<b>Power Options:</b>	<p><b>Input Power:</b></p> <ul style="list-style-type: none"> <li>• Class 2 power supply 24 VDC, current range 200 mA to 2.5 A (depending on dome lights - see dome light manufacturer for specific current requirements)</li> </ul> <p><b>Paging Wattage Requirements:</b></p> <ul style="list-style-type: none"> <li>• Minimum 125 mW per unit</li> </ul>
<b>Wireless Characteristics:</b>	<p><b>ZigBee:</b></p> <ul style="list-style-type: none"> <li>• Frequency: 2.4 GHz</li> <li>• Network type: 802.15.4 wireless mesh network</li> <li>• Range: 23 m (75 ft) with line of sight</li> </ul> <p><b>Ultrasonic transmitter:</b></p> <ul style="list-style-type: none"> <li>• Frequency: 40 kHz</li> <li>• Range: 9.1 m (30 ft)</li> </ul>
<b>Physical Characteristics:</b>	<p>Faceplate: 221R Lexan</p> <p>Impact Strength: 260 ft-lbs/in<sup>2</sup></p> <p>Actuator Material: Silicon Rubber</p> <p>Color: Off White</p> <p>Weight: 225g (8 oz)</p> <p>Dimensions: 114 mm x 162 mm x 64 mm (4.5” H x 6.375” W x 2.5” D)</p> <p>Mounting Centers: 3-9/32”</p> <p>Standard 3-gang, 2.5” Deep PVC Back Box Required</p> <p>Operating Temperature: 0° C to +50° C (32° F to 122° F)</p>

<b>Input/Output Operating Specifications:</b>	<p><b>Inputs:</b></p> <ul style="list-style-type: none"> <li>• Wet contact pair, supplied voltage is nominally 3.6 V (absolute maximum 5 V).</li> <li>• Nominal current of 1.4 mA (external loop closed) and an absolute maximum of 1.9 mA.</li> <li>• Follow manufacturer’s specifications for any attached equipment or wiring.</li> <li>• End of Line Resistor: 10K ohms +/- 5% ½W</li> </ul> <p><b>Outputs:</b></p> <ul style="list-style-type: none"> <li>• General Purpose Relays: dry contact form C, 40 VDC @ 500 mA max. per relay</li> <li>• Dome Light Relays: dry contact form A, 24 VDC @ 500 mA max. per relay</li> </ul> <p><b>Install in accordance with the Canadian Electrical Code or the National Electrical Code, and comply with all local regulations. Final acceptance subject to the Local Authority Having Jurisdiction (AHJ).</b></p>
---	--

## 8.2 NC-210 Beacon

<b>Standards:</b>	UL 1069, 2560, CSA 22.2 #205, FCC Part 15, Class “B”, CS-03
<b>Power Options:</b>	<p><b>Input Power:</b></p> <ul style="list-style-type: none"> <li>• 120 VAC @ 6.0 mA nominal</li> </ul>
<b>Wireless Characteristics:</b>	<p><b>ZigBee:</b></p> <ul style="list-style-type: none"> <li>• Frequency: 2.4 GHz</li> <li>• Network type: 802.15.4 wireless mesh network</li> <li>• Range: 23 m (75 ft) with line of sight</li> </ul> <p><b>Ultrasonic transmitter:</b></p> <ul style="list-style-type: none"> <li>• Frequency: 40 kHz</li> <li>• Range: 9.1 m (30 ft)</li> </ul>
<b>Physical Characteristics:</b>	Enclosure: Acrylonitrile Butadiene Styrene Impact Strength: 9.52 ft-lbs/in <sup>2</sup> UL94V-0 Flame Rating Color: White Weight: 142 g (5 oz) Dimensions: 104 mm x 56 mm x 32 mm (4.11” H x 2.23” W x 1.25” D) Standard 3 pole grounded NEMA 5-15P Operating Temperature: 0° C to +50° C (32° F to 122° F)

### 8.3 NC-211 Beacon

<b>Standards:</b>	UL 1069, 2560, CSA 22.2 #205, FCC Part 15, Class “B”, CS-03
<b>Power Options:</b>	<b>Input Power when connected to 120 VAC outlet:</b> <ul style="list-style-type: none"> <li>• 120 VAC @ 9.0 mA nominal</li> </ul> <b>Battery power:</b> <ul style="list-style-type: none"> <li>• Type: Lithium-ion</li> <li>• Nominal voltage: 3.7 V</li> <li>• Capacity: 500 mAh</li> </ul>
<b>Wireless Characteristics:</b>	<b>ZigBee:</b> <ul style="list-style-type: none"> <li>• Frequency: 2.4 GHz</li> <li>• Network type: 802.15.4 wireless mesh network</li> <li>• Range: 23 m (75 ft) with line of sight</li> </ul> <b>Ultrasonic transmitter:</b> <ul style="list-style-type: none"> <li>• Frequency: 40 kHz</li> <li>• Range: 9.1 m (30 ft)</li> </ul>
<b>Physical Characteristics:</b>	Enclosure: Acrylonitrile Butadiene Styrene Impact Strength: 9.52 ft-lbs/in <sup>2</sup> UL94V-0 Flame Rating Color: White Weight: 142 g (5 oz) Dimensions: 104 mm x 56 mm x 32 mm (4.11” H x 2.23” W x 1.25” D) Standard 3 pole grounded NEMA 5-15P Operating Temperature: 0° C to +50° C (32° F to 122° F)

### 8.4 NC-103 Pull Station

<b>Standards:</b>	UL 1069, 2560, CSA 22.2 #205, FCC Part 15, Class “B”, CS-03
<b>Power Options:</b>	<b>Input Power:</b> <ul style="list-style-type: none"> <li>• 2 x 1.5 V Alkaline AA Batteries</li> <li>• Nominal Current: 10 µA</li> <li>• Transmit Current: 35 mA</li> <li>• Receive Current: 25 mA</li> <li>• Transmit and Receive Frequency: 4 times a day</li> </ul>

<b>Wireless Characteristics:</b>	<b>ZigBee:</b> <ul style="list-style-type: none"> <li>• Frequency: 2.4 GHz</li> <li>• Network type: 802.15.4 wireless mesh network</li> <li>• Range: 23 m (75 ft) with line of sight</li> </ul>
<b>Physical Characteristics:</b>	Faceplate: 221R Lexan Impact Strength: 260 ft-lbs/in <sup>2</sup> Color: Off White Weight: 113 g (4 oz) Dimensions: 130 mm x 89 mm x 20 mm (5.1" H x 3.5" W x 0.8" D) Standard 1-gang, 2.5" Shallow PVC Back Box Required Operating Temperature: 0° C to +50° C (32° F to 122° F)
<b>Input Operating Specifications:</b>	Wet contact pair, supplied voltage is max 3.6 V Nominal current of 1.4 mA (external loop closed) Maximum current 5 mA Follow manufacturer's specifications for any attached equipment or wiring.

## 8.5 NC-220 ZF3 3 Input Transmitter (auxiliary device for supplementary operation)

<b>Standards:</b>	CSA 22.2 #205, FCC Part 15, Class "B", CS-03
<b>Power Options:</b>	<b>Input Power:</b> <ul style="list-style-type: none"> <li>• 1 x 3 V CR123A Battery</li> <li>• Capacity: 1550.0 mAh</li> <li>• Nominal Current: 10 µA</li> <li>• Transmit Current: 35 mA</li> <li>• Receive Current: 25 mA</li> <li>• Transmit and Receive Frequency: 4 times a day</li> </ul>
<b>Wireless Characteristics:</b>	<b>ZigBee:</b> <ul style="list-style-type: none"> <li>• Frequency: 2.4 GHz</li> <li>• Network type: 802.15.4 wireless mesh network</li> <li>• Range: 23 m (75 ft) with line of sight</li> </ul>
<b>Physical Characteristics:</b>	Enclosure: Plastic Color: Black Weight: 45 g (1.6 oz) Dimensions of Enclosure: 111 mm x 60 mm x 40 mm (4.4" W x 2.4" D x 1.6" H) Operating Temperature: 0° C to +50° C (32° F to 122° F)

<b>Input Operating Specifications:</b>	Wet contact pair, supplied voltage is max 3.6 V Nominal current of 1.4 mA (external loop closed) and an absolute maximum of 5 mA Follow manufacturer's specifications for any attached equipment or wiring
--	--

## 8.6 NC-500 Pendant

<b>Standards:</b>	UL 1069, 2560, CSA 22.2 #205, FCC Part 15, Class "B", CS-03
<b>Power Options:</b>	<b>Input Power:</b> <ul style="list-style-type: none"> <li>• 1 x 3 V CR2450 Battery</li> <li>• Capacity: 540 mAh</li> <li>• Nominal Current: 10 <math>\mu</math>A</li> <li>• Transmit Current: 35 mA</li> <li>• Receive Current: 25 mA</li> <li>• Transmit and Receive Frequency: 4 times a day</li> </ul>
<b>Wireless Characteristics:</b>	<b>ZigBee:</b> <ul style="list-style-type: none"> <li>• Frequency: 2.4 GHz</li> <li>• Network type: 802.15.4 wireless mesh network</li> <li>• Range: 23 m (75 ft) with line of sight</li> </ul> <b>Ultrasonic receiver:</b> <ul style="list-style-type: none"> <li>• Frequency: 40 kHz</li> <li>• Range: 9.1 m (30 ft)</li> </ul>
<b>Physical Characteristics:</b>	Enclosure: Germ-Wipeable Plastic Color: White & Blue Weight: 25g (0.9 oz) Dimensions: 46 mm x 38 mm x 13 mm (1.8" H x 1.5" W x 0.5" D) Operating Temperature: 0° C to +50° C (32° F to 122° F)

## 8.7 NC-2100K Coordinator Bundle

<b>Standards:</b>	UL 1069, 2560, CSA 22.2 #205, FCC Part 15/Part 68, Class "B", CS-03
<b>Power Options:</b>	<b>Input Power:</b> <ul style="list-style-type: none"> <li>• 2 x Class 2 power supply 24 VDC, 25 mA maximum</li> </ul>

<b>Wireless Characteristics:</b>	<b>ZigBee:</b> <ul style="list-style-type: none"> <li>• Frequency: 2.4 GHz</li> <li>• Network type: 802.15.4 wireless mesh network</li> <li>• Range: 23 m (75 ft) with line of sight</li> </ul> <b>Ultrasonic transmitter:</b> <ul style="list-style-type: none"> <li>• Frequency: 40 kHz</li> <li>• Range: 9.1 m (30 ft)</li> </ul>
<b>Physical Characteristics:</b>	Enclosure: Plastic Color: Black Weight: 1.18 kg (2.6 lb) (1U) 1.86 kg (4.1 lb) (2U) Dimensions: 44 mm x 438 mm x 206 mm (1.75" H x 17.25" W x 8.1" D) (1U) 86 mm x 483 mm x 211 mm (3.4" H x 19" W x 8.3" D) (2U) Operating Temperature: 0° C to +50° C (32° F to 122° F)

## 8.8 RB-MD-990 Power Supply for UL 2560 Applications Only

<b>Power Options:</b>	<b>Output Power:</b> Voltage: 24 VDC Max. current: 6.5 A <b>Input Power:</b> 120 V, 60 Hz / 240 V, 50 Hz
-----------------------	--

## 9.0 Appendix 2: UL 2560 Requirements for UPS (Uninterruptible Power Supply)

### 9.1 Server and Monitor

Power consumption for the server: 350 W

Maximum power consumption for the monitor: 65 W

The UPS model is an APC Power-Saving Back-UPS Pro-1000 (120V).

- 600 W / 1000 VA
- one 12 V / 7 Ah battery

The runtime of the UPS depends on the load applied to it. For the UPS model above, the half load and full load runtimes are:

- Half load (300 W): 14.5 min
- Full load (600 W): 3.7 min

The power consumption of the server varies over time and depends on the applications that run on it and their memory usage.

One UPS must be dedicated to the server and monitor.

### 9.2 Coordinator Bundles, Beacons, and Patient Units

Use the UPS described in section 9.1 for all MiCare devices. One UPS must be dedicated to the server and monitor, and another one or more UPSes must be used to support the other devices.

There can be more than one UPS on a site, depending on the size of the network.

#### 9.2.1 NC-2100K Coordinator Bundle

Power consumption for one Coordinator Bundle: 1.2 W

Runtime of the UPS described in section 9.1 for one Coordinator Bundle: 60 hours

#### 9.2.2 NC-210 Beacon

Power consumption for one NC-210 Beacon: 0.72 W

For example, the runtime for the UPS described in section 9.1 with 20 Beacons is 5 hours, and the runtime with 40 Beacons is 2 hour 30 minutes.

#### 9.2.3 NC-211 Beacon

Power consumption for one NC-211 Beacon: 1.08 W

For example, the runtime for the UPS described in section 9.1 with 20 Beacons is 3 hours 21 minutes, and the runtime with 40 Beacons is 1 hour 40 minutes.

#### 9.2.4 NC-2000 Patient Unit

Power consumption for one Patient Unit with NC-4LED: 4.44 W

For example, the runtime for the UPS described in section 9.1 with 10 Patient Units is 1 hour 37 minutes.



# 10.0 Appendix 3: Wiring Diagram for Emergency Call System (UL 2560)

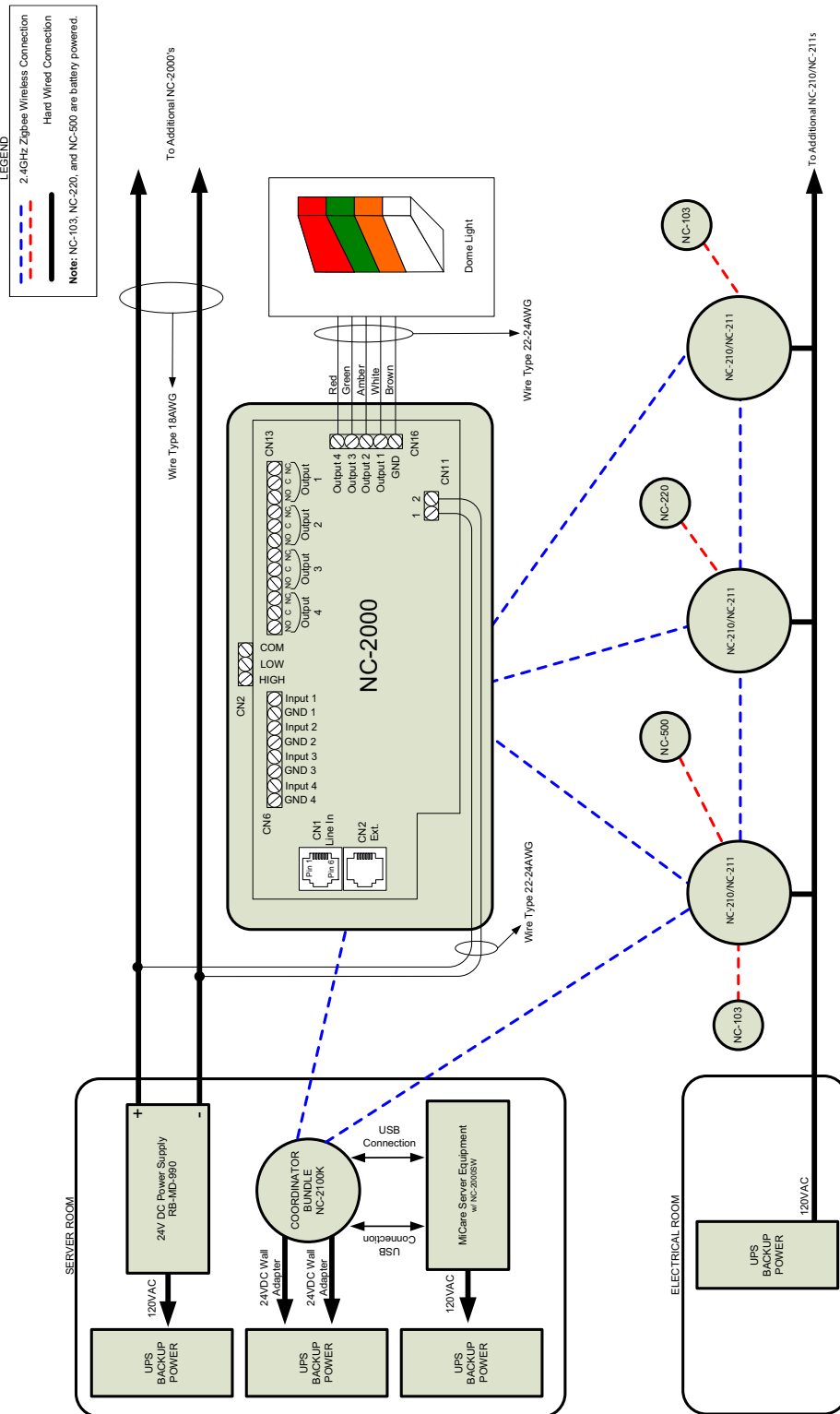

# 11.0 Appendix 4: Wiring Diagram for Nurse Call System (UL 1069)

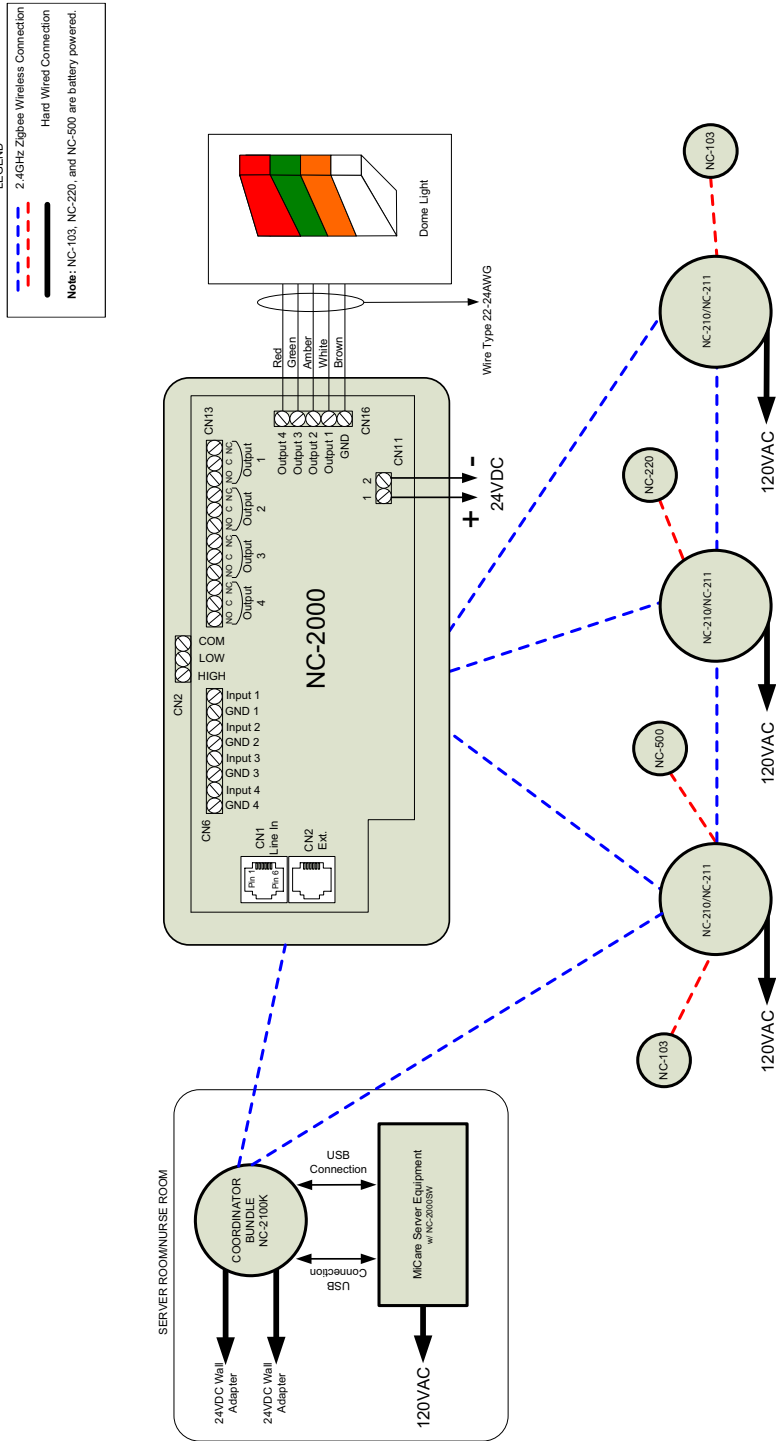

## 12.0 Appendix 5: Device Installation Table

Use the following table to keep track of the devices you install and where they are located. This information should be passed along to the administrator of the MiCare Central server so that the devices can be added to the Nurse Call and Emergency System.

**Table 5** Device installation table

Device MAC Address	Device Type							Building	Wing	Floor	Room
	Patient Unit	Beacon	Pull Station	Pendant	Staff Badge	Asset Tag	ZF3				

**Table 5 Device installation table (Continued)**

Device MAC Address	Device Type							Building	Wing	Floor	Room
	Patient Unit	Beacon	Pull Station	Pendant	Staff Badge	Asset Tag	ZF3				

## 13.0 Warranty and Warning Information

### WARNING!

Please read this document **CAREFULLY**, as it contains important warnings, life-safety, and practical information about all products manufactured by the Mircom Group of Companies, including Mircom and Secutron branded products, which shall include without limitation all fire alarm, nurse call, building automation and access control and card access products (hereinafter individually or collectively, as applicable, referred to as “**Mircom System**”).

#### NOTE TO ALL READERS:

1. **Nature of Warnings.** The within warnings are communicated to the reader out of an abundance of caution and create no legal obligation for Mircom Group of Companies, whatsoever. Without limiting the generality of the foregoing, this document shall NOT be construed as in any way altering the rights and obligations of the parties, governed by the legal documents that apply in any given circumstance.
2. **Application.** The warnings contained in this document apply to all Mircom System and shall be read in conjunction with:
  - a. the product manual for the specific Mircom System that applies in given circumstances;
  - b. legal documents that apply to the purchase and sale of a Mircom System, which may include the company’s standard terms and conditions and warranty statements;
  - c. other information about the Mircom System or the parties’ rights and obligations as may be application to a given circumstance.
3. **Security and Insurance.** Regardless of its capabilities, no Mircom System is a substitute for property or life insurance. Nor is the system a substitute for property owners, renters, or other occupants to act prudently to prevent or minimize the harmful effects of an emergency situation. Building automation systems produced by the Mircom Group of Companies are not to be used as a fire, alarm, or life-safety system.

#### NOTE TO INSTALLERS:

All Mircom Systems have been carefully designed to be as effective as possible. However, there are circumstances where they may not provide protection. Some reasons for system failure include the following. As the only individual in contact with system users, please bring each item in this warning to the attention of the users of this Mircom System. Failure to properly inform system end-users of the circumstances in which the system might fail may result in over-reliance upon the system. As a result, it is imperative that you properly inform each customer for whom you install the system of the possible forms of failure:

4. **Inadequate Installation.** All Mircom Systems must be installed in accordance with all the applicable codes and standards in order to provide adequate protection. National standards require an inspection and approval to be conducted by the local authority having jurisdiction following the initial installation of the system and following any changes to the system. Such inspections ensure installation has been carried out properly.
5. **Inadequate Testing.** Most problems that would prevent an alarm a Mircom System from operating as intended can be discovered by regular testing and maintenance. The complete system should be tested by the local authority having jurisdiction immediately after a fire, storm, earthquake, accident, or any kind of construction activity inside or outside the premises.

The testing should include all sensing devices, keypads, consoles, alarm indicating devices and any other operational devices that are part of the system.

## NOTE TO USERS:

All Mircom Systems have been carefully designed to be as effective as possible. However, there are circumstances where they may not provide protection. Some reasons for system failure include the following. The end user can minimize the occurrence of any of the following by proper training, testing and maintenance of the Mircom Systems:

6. **Inadequate Testing and Maintenance.** It is imperative that the systems be periodically tested and subjected to preventative maintenance. Best practices and local authority having jurisdiction determine the frequency and type of testing that is required at a minimum. Mircom System may not function properly, and the occurrence of other system failures identified below may not be minimized, if the periodic testing and maintenance of Mircom Systems is not completed with diligence and as required.
7. **Improper Operation.** It is important that all system users be trained in the correct operation of the alarm system and that they know how to respond when the system indicates an alarm. A Mircom System may not function as intended during an emergency situation where the user is unable to operate a panic or emergency switch by reason of permanent or temporary physical disability, inability to reach the device in time, unfamiliarity with the correct operation, or related circumstances.
8. **Insufficient Time.** There may be circumstances when a Mircom System will operate as intended, yet the occupants will not be protected from the emergency due to their inability to respond to the warnings in a timely manner. If the system is monitored, the response may not occur in time enough to protect the occupants or their belongings.
9. **Carelessness or Safety Hazards.** Moreover, smoke detectors may not provide timely warning of fires caused by carelessness or safety hazards such as smoking in bed, violent explosions, escaping gas, improper storage of flammable materials, overloaded electrical circuits or children playing with matches or arson.
10. **Power Failure.** Some Mircom System components require adequate electrical power supply to operate. Examples include: smoke detectors, beacons, HVAC, and lighting controllers. If a device operates only by AC power, any interruption, however brief, will render that device inoperative while it does not have power. Power interruptions of any length are often accompanied by voltage fluctuations which may damage Mircom Systems or other electronic equipment. After a power interruption has occurred, immediately conduct a complete system test to ensure that the system operates as intended.
11. **Battery Failure.** If the Mircom System or any device connected to the system operates from batteries it is possible for the batteries to fail. Even if the batteries have not failed, they must be fully charged, in good condition, and installed correctly. Some Mircom Systems use replaceable batteries, which have a limited life-span. The expected battery life is variable and in part dependent on the device environment, usage and type. Ambient conditions such as high humidity, high or low temperatures, or large temperature fluctuations may reduce the expected battery life. Moreover, some Mircom Systems do not have a battery monitor that would alert the user in the event that the battery is nearing its end of life. Regular testing and replacements are vital for ensuring that the batteries function as expected, whether or not a device has a low-battery monitor.
12. **Physical Obstructions.** Motion sensors that are part of a Mircom System must be kept clear of any obstacles which impede the sensors' ability to detect movement. Signals being communicated by a Mircom System may not reach the receiver if an item (such as metal, water, or concrete) is placed on or near the radio path. Deliberate jamming or other inadvertent radio signal interference can also negatively affect system operation.

13. **Wireless Devices Placement Proximity.** Moreover all wireless devices must be a minimum and maximum distance away from large metal objects, such as refrigerators. You are required to consult the specific Mircom System manual and application guide for any maximum distances required between devices and suggested placement of wireless devices for optimal functioning.
14. **Failure to Trigger Sensors.** Moreover, Mircom Systems may fail to operate as intended if motion, heat, or smoke sensors are not triggered.
  - a. Sensors in a fire system may fail to be triggered when the fire is in a chimney, walls, roof, or on the other side of closed doors. Smoke and heat detectors may not detect smoke or heat from fires on another level of the residence or building. In this situation the control panel may not alert occupants of a fire.
  - b. Sensors in a nurse call system may fail to be triggered when movement is occurring outside of the motion sensors' range. For example, if movement is occurring on the other side of closed doors or on another level of the residence or building the motion detector may not be triggered. In this situation the central controller may not register an alarm signal.
15. **Interference with Audible Notification Appliances.** Audible notification appliances may be interfered with by other noise sources such as stereos, radios, televisions, air conditioners, appliances, or passing traffic. Audible notification appliances, however loud, may not be heard by a hearing-impaired person.
16. **Other Impairments.** Alarm notification appliances such as sirens, bells, horns, or strobes may not warn or waken a sleeping occupant if there is an intervening wall or door. It is less likely that the occupants will be alerted or awakened when notification appliances are located on a different level of the residence or premise.
17. **Software Malfunction.** Most Mircom Systems contain software. No warranties are provided as to the software components of any products or stand-alone software products within a Mircom System. For a full statement of the warranties and exclusions and limitations of liability please refer to the company's standard Terms and Conditions and Warranties.
18. **Telephone Lines Malfunction.** Telephone service can cause system failure where telephone lines are relied upon by a Mircom System. Alarms and information coming from a Mircom System may not be transmitted if a phone line is out of service or busy for a certain period of time. Alarms and information may not be transmitted where telephone lines have been compromised by criminal tampering, local construction, storms or earthquakes.
19. **Component Failure.** Although every effort has been made to make this Mircom System as reliable as possible, the system may fail to function as intended due to the failure of a component.
20. **Integrated Products.** Mircom System might not function as intended if it is connected to a non-Mircom product or to a Mircom product that is deemed non-compatible with a particular Mircom System. A list of compatible products can be requested and obtained.

## Warranty

**Purchase of all Mircom products is governed by:**

<https://www.mircom.com/product-warranty>

<https://www.mircom.com/purchase-terms-and-conditions>

<https://www.mircom.com/software-license-terms-and-conditions>

## 14.0 Special Notices

### FCC Regulatory Statements

This device complies with Part 15 of the FCC Rules. Operation is subject to the following two conditions:

- (1) This device may not cause harmful interference.
- (2) This device must accept any interference received, including interference that may cause undesired operation.

This equipment has been tested and found to comply with the limits for a Class B digital device, pursuant to part 15 of the Federal Communication Commission (FCC) rules. These limits are designed to provide reasonable protection against harmful interference in a residential installation. This equipment generates, uses and can radiate radio frequency energy and, if not installed and used in accordance with the instructions, may cause harmful interference to radio communications. However, there is no guarantee that interference will not occur in a particular installation. If this equipment causes harmful interference to radio or television reception, which can be determined by turning the equipment off and on, the user is encouraged to try to correct the interference by doing one or more of the following measures:

- Reorient or relocate the receiving antenna.
- Increase the separation between the equipment and receiver.
- Connect the equipment into an outlet on a circuit different from that to which the receiver is connected.
- Consult the dealer or an experienced radio/TV technician for help.

NOTE: THE GRANTEE IS NOT RESPONSIBLE FOR ANY CHANGES OR MODIFICATIONS NOT EXPRESSLY APPROVED BY THE PARTY RESPONSIBLE FOR COMPLIANCE. SUCH MODIFICATIONS COULD VOID THE USER'S AUTHORITY TO OPERATE THE EQUIPMENT.

### RF Exposure Warning

This equipment complies with FCC radiation exposure limits set forth for an uncontrolled environment. In order to avoid the possibility of exceeding the FCC radio frequency exposure limits, human proximity to the antenna shall not be less than 20 cm during normal operation and must not be co-located or operating in conjunction with any other antenna or transmitter.

### ISED Regulatory Statements

This device complies with ISED Canada license-exempt RSS standard(s). Operation is subject to the following two conditions: (1) this device may not cause interference, and (2) this device must accept any interference, including interference that may cause undesired operation of the device.

Le présent appareil est conforme avec ISED Canada applicables aux appareils radio exempts de licence. L'exploitation est autorisée aux deux conditions suivantes: (1) l'appareil ne doit pas produire de brouillage, et (2) l'utilisateur de l'appareil doit accepter tout brouillage radioélectrique subi, même si le brouillage est susceptible d'en compromettre le fonctionnement.

CAN ICES-3 (B)/NMB-3(B)



## RF Exposure Information

This equipment complies with ISED RSS-102 radiation exposure limits set forth for an uncontrolled environment. This transmitter must be installed to provide a separation distance of at least 20 cm from all persons and must not be co-located or operating in conjunction with any other antenna or transmitter.

Cet équipement est conforme avec ISED RSS-102 des limites d'exposition aux rayonnements définies pour un environnement non contrôlé. Cet émetteur doit être installé à au moins 20 cm de toute personne et ne doit pas être colocalisé ou fonctionner en association avec une autre antenne ou émetteur.



© Mircom 2018  
Printed in Canada  
Subject to change without prior notice

[www.mircom.com](http://www.mircom.com)

**CANADA - Main Office**  
25 Interchange Way  
Vaughan, ON L4K 5W3  
Tel: (905) 660-4655  
(888) 660-4655  
Fax: (905) 660-4113

**U.S.A**  
4575 Witmer Industrial Estates  
Niagara Falls, NY 14305  
Tel: (905) 660-4655  
(888) 660-4655  
Fax: (905) 660-4113