

OVERHEAD AUDIO UNIT

Model 2881115 - Accessory

Model 2635986 - OEM

21A10201

FCC STATEMENTS:

CAUTION: Changes or modifications to this equipment not expressly approved by the manufacturer could void the user's authority to operate the equipment. The equipment complies with FCC RF exposure limits set forth for an uncontrolled environment. This equipment has been tested and found to comply with the limits for a Class B digital device, pursuant to part 15 of the FCC Rules.

Note: This equipment has been tested and found to comply with the limits for a Class B digital device, pursuant to part 15 of the FCC Rules. These limits are designed to provide reasonable protection against harmful interference in a residential installation. This equipment generates, uses and can radiate radio frequency energy and, if not installed and used in accordance with the instructions, may cause harmful interference to radio communications. However, there is no guarantee that interference will not occur in a particular installation. If this equipment does cause harmful interference to radio or television reception, which can be determined by turning the equipment off and on, the user is encouraged to try to correct the interference by one or more of the following measures:

- Reorient or relocate the receiving antenna.
- Increase the separation between the equipment and receiver.
- Connect the equipment into an outlet on a circuit different from that to which the receiver is connected.
- Consult the dealer or an experienced radio/TV technician for help

NOTES

A series of horizontal dashed lines for taking notes.

NOTES

CONTENTS

USER INTERFACE AND CONTROLS	2
Control Panel Layout	2
Key Names	2
ROTARY KNOB AND MENU KEY	3
Rotary Knob Operation	3
Menu Key Operation	3
Using the Rotary Knob and Menu Key	4
GETTING STARTED	5
Powering the Unit On or Off	5
Input Source Screens	5
Adjusting Volume Level	6
Muting Output	6
Adjusting Tone	7
Adjusting Screen Brightness	7
TUNER	8
Listening to the Tuner	8
Tuner Source Screens	8
Tuning Methods	9
Adding and Removing Presets	10
AUXILIARY INPUT	11
Listening to Auxiliary Input	11
Auxiliary Source Screen	11
BLUETOOTH	12
Playing Content	12
Bluetooth Source Screen	12
Controlling Bluetooth Playback	12
OVERHEAD UNIT CONNECTIONS	13
Connecting the Overhead Unit	13
APPENDICES	14
Troubleshooting	14



TROUBLESHOOTING

Resetting the unit.

Should the overhead unit become unresponsive:
 Remove power for 5 minutes and then reconnect.



ROTARY KNOB OPERATION

You can use the rotary knob two ways to control the operation of the overhead unit.

1		Rotary Turn
2		Press

MENU KEY OPERATION

You can use the Menu key to open or exit from menus:

	Menu Key	Press the Menu key to open a menu.
	Menu Exit	<p>In an open menu you can use the Menu key at any time to save changes and exit:</p> <ul style="list-style-type: none"> • Press the Menu key to exit from the current menu level. • Press and hold the Menu key to exit from the menu completely. <p>Time out feature: after a few seconds of inactivity, the menu exits and any changes are saved automatically.</p>

USING THE ROTARY KNOB AND MENU KEY

You can use the rotary knob and Menu key to adjust levels and access menus.

ADJUSTING LEVELS

Use the rotary knob and Menu key to adjust levels on the overhead unit; for example, to adjust the volume level:

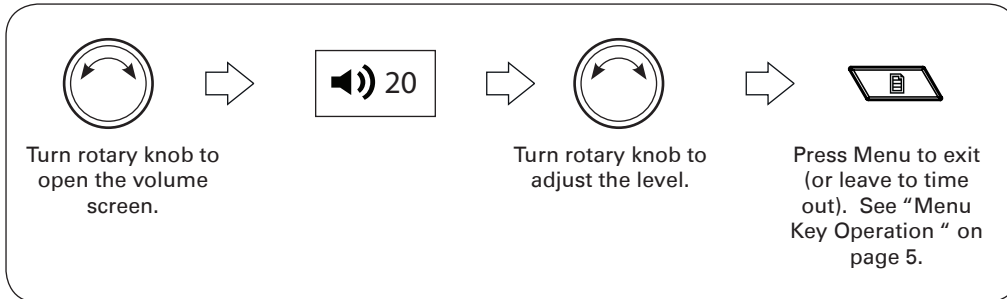

ACCESSING MENUS

Use the Menu key and rotary knob to access menus to change settings. For example, to access the Settings menu while in Tuner or AUX mode:

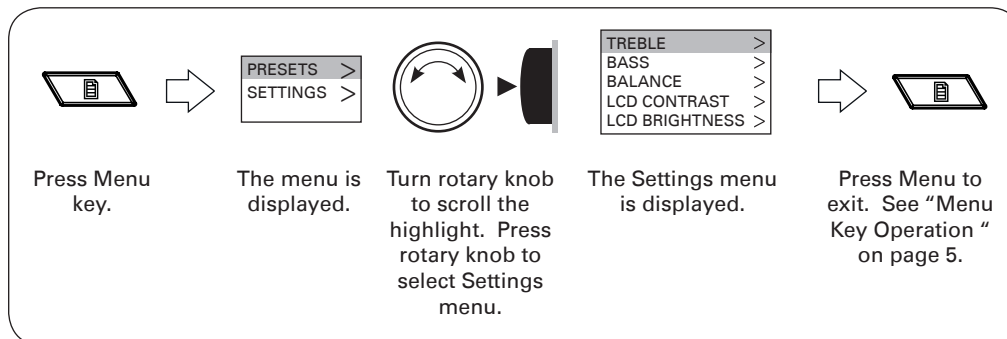

MULTI-LEVEL MENUS

All of the menus on the overhead unit have more than one level. To access items in multi-level menus:

- Turn the rotary knob to highlight a menu item, then
- Press the rotary knob to select the highlighted item.
- Repeat these steps as many times as necessary to reach the menu item you require.

In this manual, accessing a multi-level menu item is shown by listing the menu items in order as in the following example:

SETTINGS >TONE

The above examples means: "turn and then press the rotary knob to select Settings menu" then "turn and press the rotary knob to select the Tone menu."

OVERHEAD UNIT CONNECTIONS

CONNECTING THE OVERHEAD UNIT

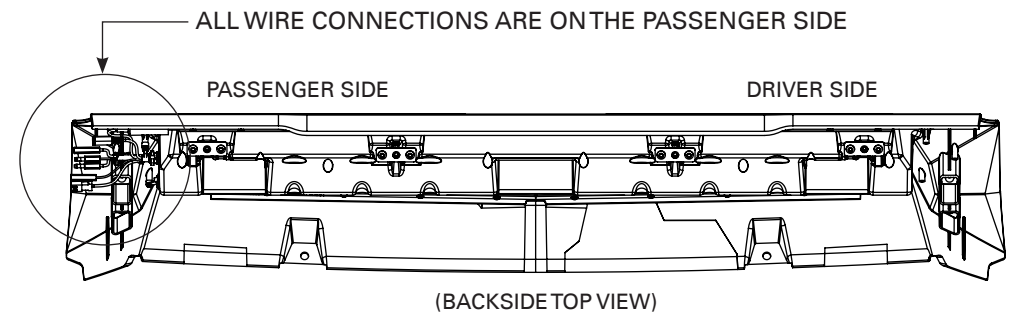

ANTENNA

AUXILIARY (3.5MM) INPUT

GROUND (BROWN)

KEY POWER (ORANGE)

RADIO B+ (RED)

REMOTE (BLUE)

AUDIO LINE OUT

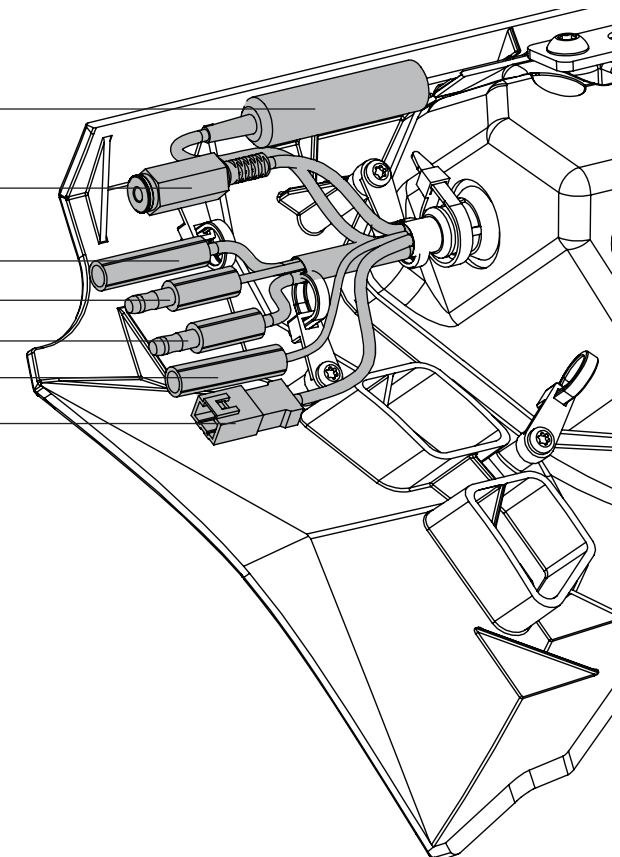

BLUETOOTH

PLAYING CONTENT

The overhead unit can accept audio from devices with Bluetooth.

To listen to input from a Bluetooth device:

Press the Input source key [] until the Bluetooth input source screen is displayed.

Continuing to press the key will display the input source screens for AM, FM and AUX as described in the section "Input Source Screens."

BLUETOOTH SOURCE SCREEN

The input source screen displayed when you select Bluetooth input is shown in the figure below.

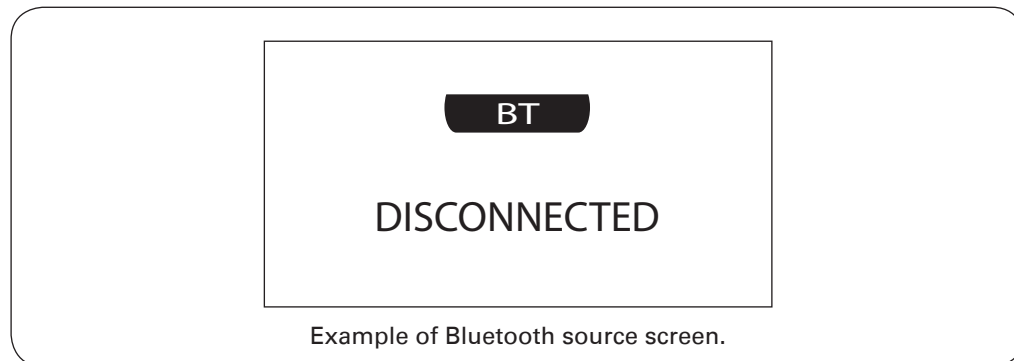

The source screen will show disconnected until a device is paired.

To pair a device:

- Make sure source screen says disconnected.
- Search for "MTX AUDIO" on your Bluetooth enabled device.
- Once you have connected the source screen will say connected and you will also hear a connection beep.

CONTROLLING BLUETOOTH PLAYBACK

You can control your device from the overhead unit using the Back, Forward and Play/Pause keys as shown on page 2.

GETTING STARTED

POWERING THE UNIT ON OR OFF

When you power on the overhead unit it will automatically start playing music from the most recently selected input source.

TO POWER THE UNIT ON OR OFF

 POWER	<ul style="list-style-type: none">• Momentarily press the Power key on the unit. As the unit starts up, a splash screen is displayed for several seconds, followed by the input source screen for the current input source.• When the unit is on, momentarily press the Power key to power off the unit.
--	---

INPUT SOURCE SCREENS

The overhead unit supports inputs from several different sources:

- AM/FM radio
- Bluetooth
- Auxiliary Input

Press the Input source key [] to step through the input source types in the following order:



When you select one of these sources, the overhead unit displays a source screen, similar to the AM source screen shown in Figure 1 below. The title bar always shows the source name. Additional information varies depending on the source type you have selected.

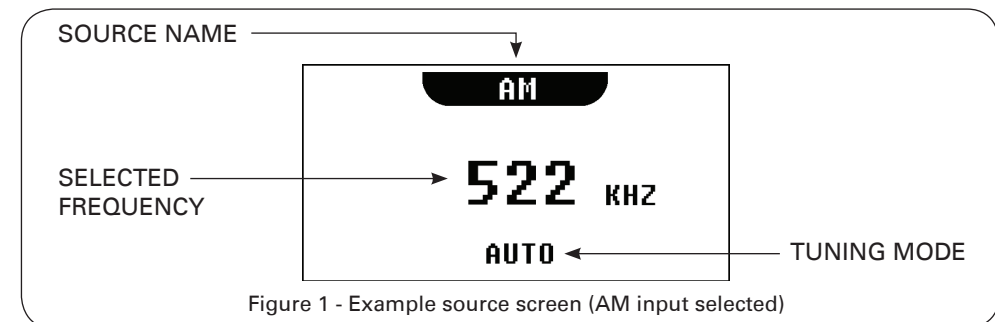

ADJUSTING VOLUME LEVEL

To adjust the volume level:

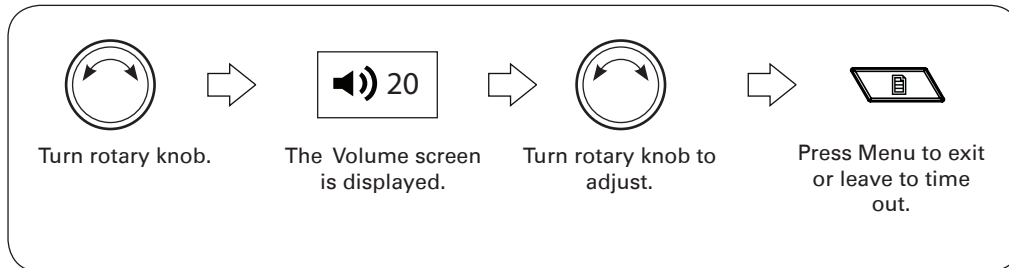

MUTING OUTPUT

To mute and unmute the volume:

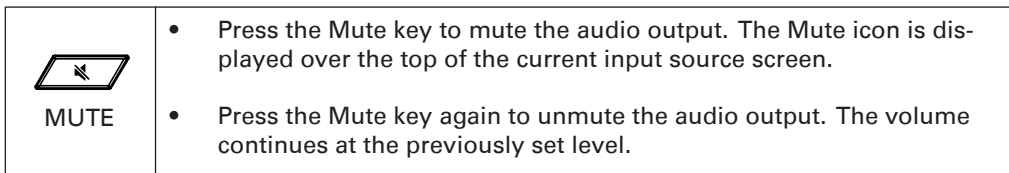

AUXILIARY INPUT

LISTENING TO AUXILIARY INPUT

The overhead unit can accept audio from devices with an audio output.

To listen to input from an auxiliary device:

Press the Input source key [] until the AUX input source screen is displayed.

Continuing to press the key will display the input source screens for AM, FM and Bluetooth as described in the section "Input Source Screens."

AUXILIARY SOURCE SCREEN

The input source screen is displayed when you select auxiliary input, shown in Figure 4 below.

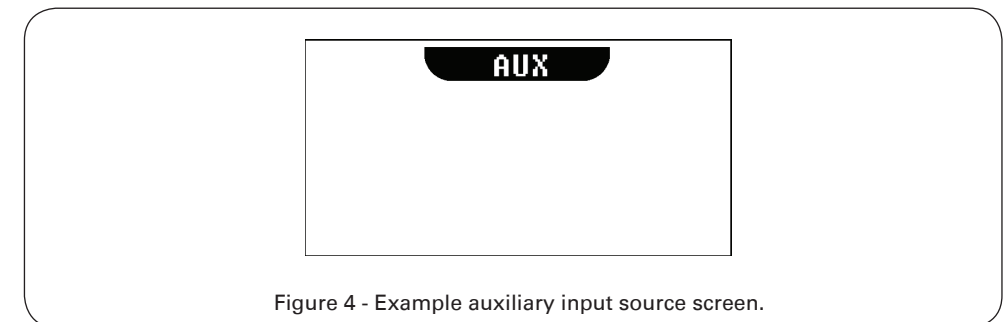

ADDING AND REMOVING PRESETS

The overhead unit allows you to set up your favorite AM/FM stations as presets for easy recall.

Note: Up to 15 presets can be stored for each radio band.

When you are using the tuner, the Play/Pause, Forward, Backward and Menu keys provide special options to allow you to work with preset frequencies (AM/FM).



To add a new preset:

Do one of the following.

1. Tune the overhead unit to the required frequency.
2. Press and hold down the Play/Pause key. The message: "Preset saved" is displayed briefly.

or

1. Press the Menu key.
2. Turn and then press the rotary knob to select Presets > Save current. The message: "Preset saved" is displayed briefly.

Note: New presets must be unique. If you try to create a preset for the same frequency as an existing one, the unit displays the message: "Previously saved."

To remove one or more presets:

1. Press the Menu key.
2. Turn and then press the rotary knob to select Presets > Remove preset.
3. Do one of the following (there is no warning or confirmation prompt before deletion):
 - Select Remove all presets and press the rotary knob to remove all current presets. The message: "Presets removed" is displayed briefly.
 - Select a preset and press the rotary knob to remove the selected preset. The selected preset is removed from the list.
4. Press the Menu key (or leave to time out) to exit.

ADJUSTING TONE

To adjust the bass or treble level:

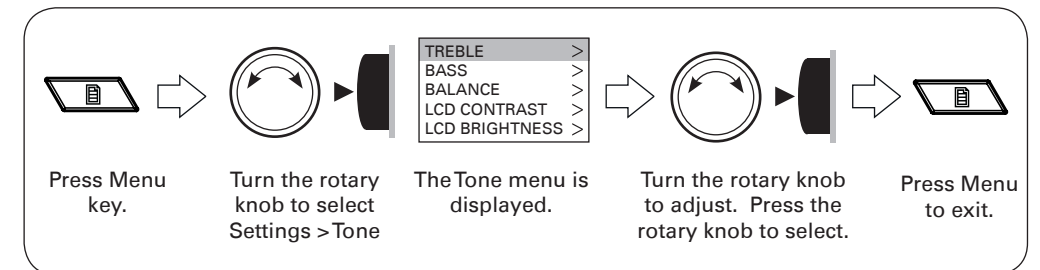

ADJUSTING SCREEN BRIGHTNESS

Use the LCD menu to adjust the contrast or brightness of the screen display.

You can press the Menu key at any time (or leave to time out) to save the current brightness level and exit.

To adjust the contrast or brightness of the display screen:

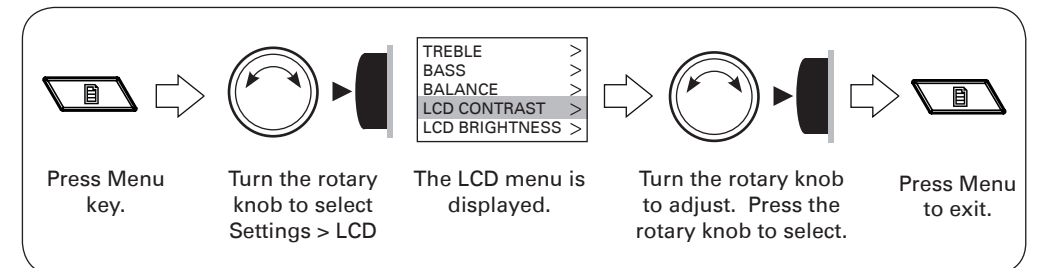

TUNER

LISTENING TO THE TUNER

To select one of the available tuner bands:

Press the Input source key [] to select input from each of the following in turn:

- AM
- FM

The applicable input source screen is displayed for each band.

Continuing to press the key will display the input source screens for Bluetooth and Auxiliary as described in the section "Input Source Screens" on page 5.

TUNER SOURCE SCREENS

AM/FM

An example of a typical tuner input source screen is shown in Figure 2 below.

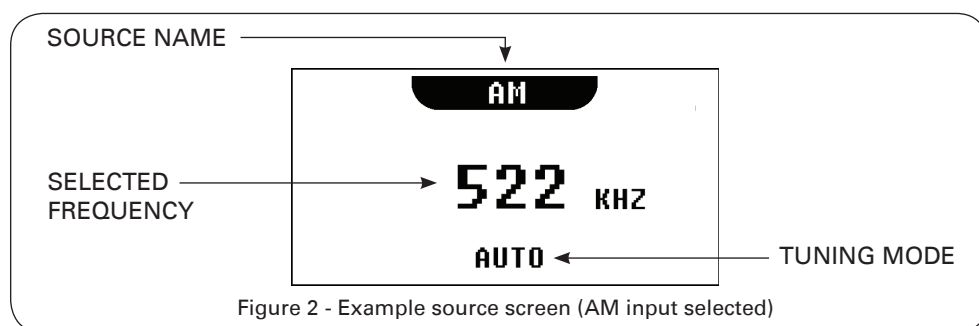

Figure 2 - Example source screen (AM input selected)

TUNING METHODS

You can use three methods to tune the overhead unit: automatic, manual and preset.

				
Rotary knob	Menu key	Play/Pause	Forward	Backward

To tune to a required frequency, channel or preset:

Press the Play/Pause key to step through the available tuning methods for each band.

Tuning Method	When tuning with this method...
Auto	<ul style="list-style-type: none"> • Press the Forward or Backward key to start searching for available stations. <p>Note: The search stops when a station is found or when the unit has scanned all available frequencies once.</p>
Manual	<ul style="list-style-type: none"> • Press the Forward or Backward key to step through the range of frequencies one at a time.
Preset	<ul style="list-style-type: none"> • Press the Forward or Backward key to step through available presets (only available if there are two or more presets) • To tune to a specific preset: <ol style="list-style-type: none"> a. Press the Menu key. b. Press the rotary knob to select Presets. c. Turn the rotary knob to highlight the required preset. d. Press the rotary knob to tune to the highlighted preset. e. Menu exit. See "Menu Key Operation" <p>For further details, see "Adding and Removing Presets."</p>