

User's Manual

Blu-ray Disc Player

BD-1G

FCC CAUTION

Changes or modifications not expressly approved by the party responsible for compliance could void the user's authority to operate the equipment.

This transmitter must not be co-located or operated in conjunction with any other antenna or transmitter.

This equipment complies with FCC/IC radiation exposure limits set forth for an uncontrolled environment and meets the FCC radio frequency (RF) Exposure Guidelines and RSS-102 of the IC radio frequency (RF) Exposure rules. This equipment should be installed and operated keeping the radiator at least 20cm or more away from person's body.

Cet équipement est conforme aux limites d'exposition aux rayonnements énoncées pour un environnement non contrôlé et respecte les règles les radioélectriques (RF) de la FCC lignes directrices d'exposition et d'exposition aux fréquences radioélectriques (RF) CNR-102 de l'IC. Cet équipement doit être installé et utilisé en gardant une distance de 20 cm ou plus entre le dispositif rayonnant et le corps.

This device complies with Part 15 of FCC Rules and Industry Canada licence-exempt RSS standard(s). Operation is subject to the following two conditions: (1) this device may not cause interference, and (2) this device must accept any interference, including interference that may cause undesired operation of this device.

Le présent appareil est conforme aux la partie 15 des règles de la FCC et CNR d'Industrie Canada applicables aux appareils radio exempts de licence. L'exploitation est autorisée aux deux conditions suivantes : (1) l'appareil ne doit pas produire de brouillage, et (2) l'utilisateur de l'appareil doit accepter tout brouillage radioélectrique subi, même si le brouillage est susceptible d'en compromettre le fonctionnement.

Data transmission is always initiated by software, which is then passed down through the MAC, through the digital and analog baseband, and finally to the RF chip.

Several special packets are initiated by the MAC. These are the only ways the digital baseband portion will turn on the RF transmitter, which it then turns off at the end of the packet.

Therefore, the transmitter will be on only while one of the aforementioned packets is being transmitted. In other words, this device automatically discontinues transmission in case of either absence of information to transmit or operational failure.

Disc Menu BD

Press MEDIA on the remote control and then select CD/DVD/BD, USB, HDMI, AUX, or Photo Viewer.

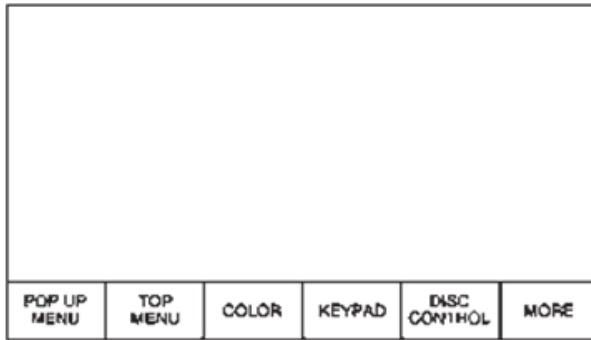

Press MENU on the remote control once to display menus based on the media.

Choose from POP UP MENU (BD Only), TOP MENU, COLOR, KEYPAD, DISC CONTROL, and MORE (SETTINGS, PREVIOUS, NEXT, STILL OFF).

To close, press the MENU button or Back button, or wait for the time out.

Disc Menu DVD

Press MENU on the remote control once to select from TOP MENU, KEYPAD, STOP DISC, PHOTO, and SETTINGS.

To close, press MENU or Back, or wait for the time out.

CD Menu

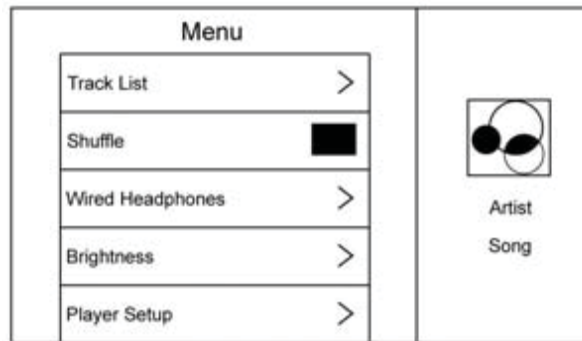

Select from:

- Track List
- Shuffle
- Disc Information (if available)
- Wired Headphones
- Brightness

- Player Setup: Audio Compression, Auto Enter (if available)
- DivX VOD
- Title Search (if available)
- Software Information

Pop Up Menu (BD Only)

Select POP UP MENU from the menu options to display the disc menu on top of the movie. Make a selection to exit the Pop-up menu. When the Pop-up menu is opened, the overlay/Interaction Selector menu will be closed. The Pop-up menu is disc dependent and may or may not time out on its own.

Top Menu BD/DVD

Select this item to display the menu for the DVD or BD. Make a selection to exit the TOP MENU. TOP MENU is not available for BDAV, DVD-VR, and AVC-REC.

Color (BD Only)

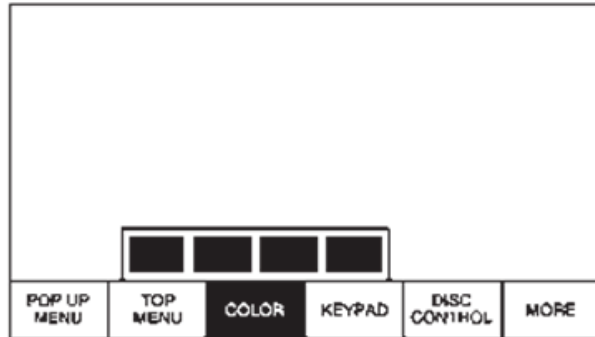

Select COLOR to display the four color button options: blue, yellow, red, and green. Highlight a color option and press ENTER and the appropriate action will be carried out. Press the Back button or MENU button, or wait for the 15-second time out to close the menu. Press the down arrow on the yellow color to keep the overlay menu up, but close the color menu. The color menu is disc dependent; selecting colors for discs that do not support this feature will have no function.

Keypad BD/DVD

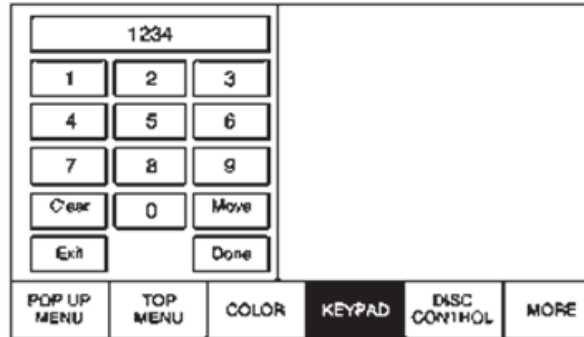

Press KEYPAD to display the single digit entry keypad. To close the keypad, press the Back button or MENU button, wait for the menu to time out, or press the down arrow from the Exit or Done buttons to keep the menu up but close the keypad. The keypad is disc dependent; selecting numbers for discs that do not support this feature will have no function.

The keypad input is limited to four digits. Any digits entered beyond four will be discarded.

Press the Clear button to clear one digit at a time. Press and hold the Clear button to clear all entered digits.

Disc Control (BDAV and BDMV Only)

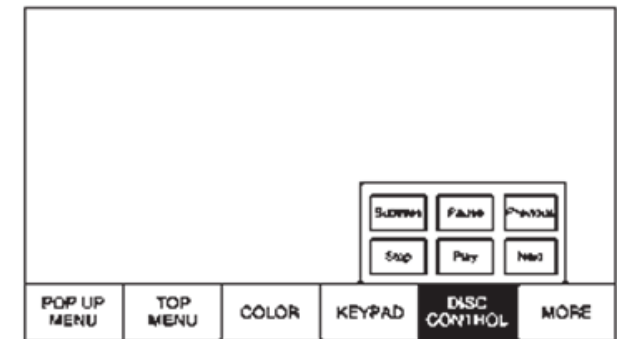

Press DISC CONTROL to display options for subtitles, play, pause, track forward, track previous, and stop the disc. Press the Back button or MENU button, or wait for the time out to close the menu. Press the down arrow from Stop, Play, or Next to keep the overlay menu up, but close the disc control menu. The disc control menu is disc

dependent; selecting controls for discs that do not support this feature will have no function.

Stop Disc (DVD Only)

Press Stop to close the overlay menu and open the Disc Stopped screen. Press Menu on the screen to open the Disc Stopped menu. Select from Resume Playback, Top Menu, Title Search, Restart Disc, Browse Media, and Player Setup. Some of these options are not available while the disc is playing.

Resume Playback: Returns to the current position on the disc and resumes play.

Top Menu: Returns to the disc provided menu.

Title Search (BDMV, AVCHD, and DVD-V only): Provides a keypad.

Browse Media (BDAV, DVD-A, DVD-VR, AVCREC only): Allows the media on the disc to be searched in a list format.

Restart Disc: Allows the disc to restart from the beginning.

More BD/DVD

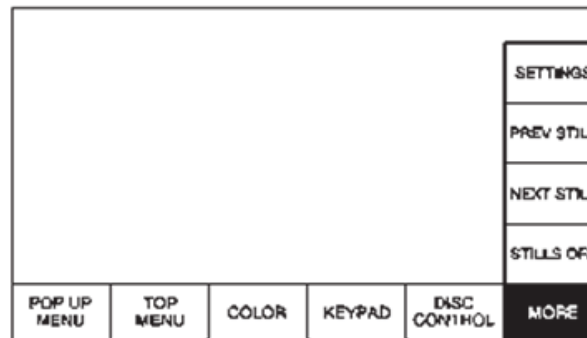

The MORE submenu includes both the SETTINGS item and items related to still pictures.

Prev Still/Next Still/Stills Off

This feature allows for turning stills off, going to the previous still, or advancing to the next still picture. PREV STILL will go back to the previous picture. NEXT STILL will advance to the next picture in sequential order. STILLS OFF will return to the designated home still, if it is available. Press the Back

button or MENU button, or wait for the 15-second time out to close the menu. Press the down arrow on the bottom option to close the next still pop-up. The menu will remain up. This feature is disc dependent.

This feature can also be accessed from the Photo button on the DVD Disc Menu depending on the disc.

Settings BD/DVD

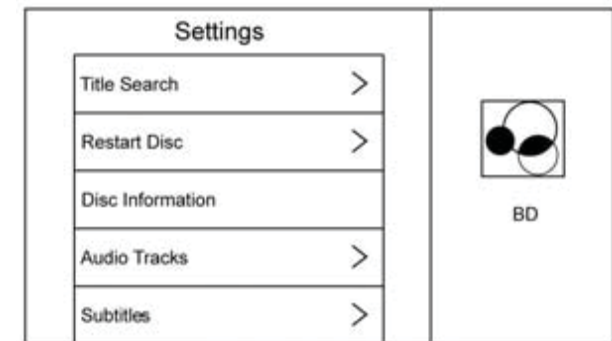

Select to access:

- Browse Media (BDAV, AVCREC, DVD-A, DVD-VR Only): Allows browsing by Video List or Playlist.

- Title Search (AVCHD, DVD-V, BDMV Only): This allows the titles provided by the disc to be searched. Select this option to bring up a keypad to search for specific titles.
- Restart Disc: Restarts the disc from the beginning.
- Disc Information (if available)
- Audio Tracks
- Subtitles
- Angle (BDMV, DVD-V, DVD-A Only): Select an angle by using the up and down arrows to highlight the option, and then press ENTER or the right arrow.
- Screen Mode: Use Screen Mode to adjust the framing on the RSE display. Select Normal, Wide, or Zoom. Screen Mode only applies to video sources and should be maintained if the disc is ejected.

- Wired Headphones: Use Wired Headphones to listen to audio on the wired headphones. The headphone audio plays depending on which screen is selected. The default is screen 1 audio.
- Brightness: Increase the brightness by using the up or right arrow and decrease the brightness by using the down or left arrow. Each screen brightness can be adjusted separately.
- Player Setup: See “Player Setup” later in this section.
- DivX VOD
- Software Information

Player Setup BD/DVD

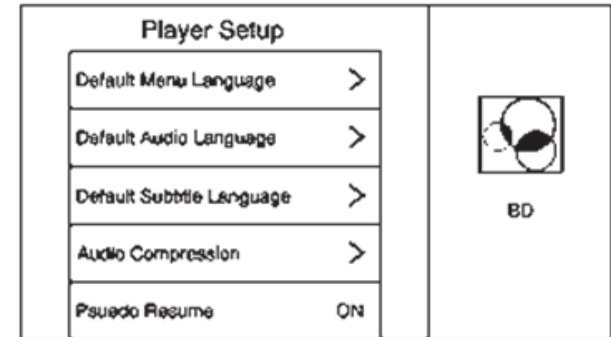

Player Setup may include:

- Default Menu Language: With no disc inserted, select from a list of languages or enter a language code.
- Default Audio Language: With no disc inserted, select from a list of languages or enter a language code.
- Default Subtitle Language: With no disc inserted, select from a list of languages or enter a language code.

- Audio Compression: When on, the RSE will attempt to reduce the difference between the audio highs and lows.
- Pseudo Resume: When on, the RSE will attempt to resume play of the video where it left off. This can be turned on or off.
- Auto Enter: When on, the RSE will attempt to start play of the video when the disc is inserted. This feature can be turned on or off. Not all discs support this feature.
- Audio Channel (AVCREC, DBAV, DVD-VR Only) contains: Stereo, Left Mono, and Right Mono. Audio Channel is available from the Settings menu. Default will be determined by the disc.
- Format Internal User Memory: Only shown when no disc is inserted.

Enter Language Code

Enter the desired language code.

Language/Code		User Code
Japanese	JPN	7465
English	ENG	6978
French	FRA	7082
German	DEU	6869
Italian	ITA	7384
Spanish	SPA	6983
Dutch	NLD	7876
Russian	RUS	8285
Chinese	ZHO	9072
Korean	KOR	7579
Greek	ELL	6976
Afar	AAR	6565
Abkhazian	ABK	6566
Afrikaans	AFR	6570
Amharic	AMH	6577
Arabic	ARA	6582

Assamase	ASM	6583
Aymara	AYM	6589
Azerbaijani	AZE	6590
Bashkir	BAK	6665
Byelorussian	BEL	6669
Bulgarian	BUL	6671
Bihari	BIH	6672
Bislama	BIS	6673
Bengali	BEN	6678
Tibetan	BOD	6679
Breton	BRE	6682
Catalan	CAT	6765
Corsican	COS	6779
Czech	CES	6783
Welsh	CYM	6789
Danish	DAN	6865
Bhutani	DZO	6890
Esperanto	EPO	6979
Estonian	EST	6984

Basque	EUS	6985
Persian	FAS	7065
Finnish	FIN	7073
Fiji	FIJ	7074
Faroese	FAO	7079
Friesian	FRY	7089
Irish	GLE	7165
Scots-Gaelic	GLA	7168
Galician	GLG	7176
Guarani	GRN	7178
Gujarati	GUJ	7185
Hausa	HAU	7265
Hindi	HIN	7273
Croatian	HRV	7282
Hungarian	HUN	7285
Armenian	HYE	7289
Interlingua	INA	7365
Interlingue	ILE	7369
Inupiak	IPK	7375

Indonesian	IND	7368
Icelandic	ISL	7383
Hebrew	HEB	7269
Yiddish	YID	8973
Javanese	JAV	7487
Georgian	KAT	7565
Kazakh	KAZ	7575
Greenlandic	KAL	7576
Cambodian	KHM	7577
Kannada	KAN	7578
Kashmiri	KAS	7583
Kurdish	KUR	7585
Kirghiz	KIR	7589
Latin	LAT	7665
Lingala	LIN	7678
Laothian	LAO	7679
Lithuanian	LIT	7684
Latvian	LAV	7686
Malagasy	MLG	7771

Maori	MRI	7773
Macedonian	MKD	7775
Malayalam	MAL	7776
Mongolian	MON	7778
Moldavian	MOL	7779
Marathi	MAR	7782
Malay	MSA	7783
Maltese	MLT	7784
Burmese	MYA	7789
Nauru	NAU	7865
Nepali	NEP	7869
Norwegian	NOR	7879
Occtian	OCI	7967
Oromo	ORM	7977
Oriya	ORI	7982
Panjabi	PAN	8065
Polish	POL	8076
Pashto, Pushto	PUS	8083
Portuguese	POR	8084

Quechua	QUE	8185
Rhaeto-Romance	ROH	8277
Kirundi	RUN	8278
Romanian	RON	8279
Kinyarwanda	KIN	8287
SanSkrit	SAN	8365
Sindhi	SND	8368
Sangho	SAG	8371
Serbo-Croatian	SCR	8372
Singhalese	SIN	8373
Slovak	SLK	8375
Uzbek	UZB	8590
Vietnamese	VIE	8673
Volapuk	VOL	8679
Wolof	WOL	8779
Xhosa	XHO	8872
Yoruba	YOR	8979
Zulu	ZUL	9085
Slovenian	SLV	8376

Samoan	SMO	8377
Shona	SNA	8378
Somali	SOM	8379
Albanian	SQI	8381
Serbian	SRP	8382
Siswaiti	SSW	8383
Sesotho	SOT	8384
Sundanese	SUN	8385
Swedish	SWE	8386
Swahili	SWA	8387
Tamil	TAM	8465
Telugu	TEL	8469
Tajik	TGK	8471
Thai	THA	8472
Tigrinya	TIR	8473
Turkmen	TUK	8475
Tagalog	TGL	8476
Setswana	TSN	8478
Tonga	TON	8479

Turkish	TUR	8482
Tsonga	TSO	8483
Tatar	TAT	8484
Twi	TWI	8487
Ukrainian	UKR	8575
Urdu	URD	8582

Errors

Errors can occur if the local storage area has been broken or if the ignition is turned off during formatting. If the screen is closed during formatting, this will not interrupt the formatting. If the screen is opened again, the current state of format will be displayed. If an error occurs, the Error screen will display when the ignition is turned on.

Wired Headphones

To select the headphone audio for the wired headphone jack based on screen 1 or screen 2, press ENTER

or the right arrow on the remote. Press the Back button to exit the menu.

The headphones are linked to screen 1 by default.

Player Setup (CD-DA Only)

This allows access to Audio Compression and Auto Enter.

Title Search (CD-DA Only)

This displays a keypad. Press Stop to close the overlay menu and open the Disc Stopped screen. Press Menu on the screen to open the Disc Stopped menu. Select Title Search.

Disc Information (CD-DA Only)

If the inserted disc is a BDMV, BDAV, AVCHD, AVCREC, DVD-Video, or DVD-VR, the disc title should display. If the inserted disc is DVD-Audio, DTS-CD, CDDA, or Mixed-CD, the track number will display.

DivX®

This indicates the vehicle is registered to play DivX media and states how to obtain more information.

Software Information

This allows access to Version Information, Save Vehicle Info to USB, and View Open Source.

Save Vehicle Info to USB allows the current version to be saved to a jump drive, which must be done before an update can be performed.

View Open Source indicates where software information can be found.

Changing Between SCREEN 1 and SCREEN 2

For single overhead screen systems only:

Although two audio sources can be listened to at one time, only one video source can be viewed on the overhead screen at a time.

Press the SCREEN 1 or SCREEN 2 button on the remote control to change between which source will display on the overhead screen.

When SCREEN 1 is being displayed and the SCREEN 2 button on the remote is pressed, the source for SCREEN 2 will be displayed. The audio for SCREEN 1 is available on channel 1 of the headphones and the audio for SCREEN 2 is available on channel 2 of the headphones. Change the channel on the headphones to the desired screen source.



One user can listen to the audio from SCREEN 1 and view the source on the overhead display while another user can listen to a separate audio source by changing the channel on the wireless headphones or setting their wired headphones to SCREEN 2 in the MENU.

Rear Media



Use REAR MEDIA to select AUX, Disc, USB, or HDMI sources for the Rear Seat Entertainment (RSE). When using the REAR MEDIA

button to select a source, both rear screens will be sourced and begin playback of the first available file. The video will only display on the front screen if the vehicle is in P (Park). When the vehicle is in any other gear, the front screen displays the active media source.

Previous Track/Next Track

Press  or  to select the previous or next track on the current media.

Play/Pause

Press  to play or  to pause, depending on the current selection. A time bar displays when the pause button is pressed.

Menu (DVD/BD/HDMI/USB/AUX/VCD)

MENU is only available in D (Drive). Press the MENU button to display these menu options:

- Tone Settings
- Auto Volume Control
- Traffic Announcements

Tone Settings (DVD/BD)

Tone settings for bass, mid, and treble are available in any source mode. Once set, tone settings are set for all sources.

Auto Volume Control (DVD/BD)

Automatic Volume Control (AVC) adjusts the volume of the audio based on the speed or ambient noise of the vehicle. Some vehicles may be equipped with the Bose AudioPilot system. In these cases, the Auto Volume main menu item is replaced with the Bose AudioPilot menu item. AVC or Bose AudioPilot is available to use with any

source mode.

Traffic Announcements (DVD/BD)

Traffic program alerts will display in the RSE system. The video will continue to play and the audio will mute, depending on the alert.

Closing the Menu (DVD/BD)

Press the Back or Exit button to close a menu. This will return to the RSE application on the previously viewed screen.

Power

Press the power button on the screen to turn the rear RSE screens on or off. The front screen will continue to operate when the rear screens are turned off. The rear screens can be turned back on by pressing the power button again or from the rear seat by using the remote. Select SCREEN 1 or 2 and press the power button.

Headphones



1. Power Indicator Light
2. Channel 1 or 2 Switch
3. Volume Control
4. Power Button
5. Battery Cover

RSE includes two or four 2-channel wireless headphones depending on the vehicle model. The headphones are used to listen to various multimedia. The wireless headphones have a power button, Channel 1 or 2 switch, and a volume control.

Press the power button to turn on the headphones. A light on the

headphones comes on. If the light

does not come on, check the batteries. Intermittent sound or static can also indicate weak batteries. See “Battery Replacement” later in this section.

Turn the headphones off when not in use.

Press the center of the right side of the headphone to change the channel. Channel 1 will provide audio associated with screen 1 and channel 2 will provide audio associated with screen 2.

Infrared transmitters are on the top of the left seatback video screen or in front of the second overhead screen. The headphones shut off automatically to save the battery power if the RSE system is off or if the headphones are out of range of the transmitters for more than three minutes. Moving too far forward or stepping out of the vehicle can cause the headphones to lose the signal or have static.

Use the volume control on the

headphones to adjust the volume.

For best audio performance, wear the headphones as indicated with L (Left) and R (Right) on the ear pads. Do not let anything cover the ear pads.

purchase replacement ear pads, call 1-888-293-3332 or contact your dealer.

{
Caution

Do not store the headphones in heat or direct sunlight. This could damage the headphones and repairs will not be covered by the warranty. Storage in extreme cold can weaken the batteries. Keep the headphones stored in a cool, dry place.

If the foam ear pads become worn or damaged, the pads can be replaced separately. To

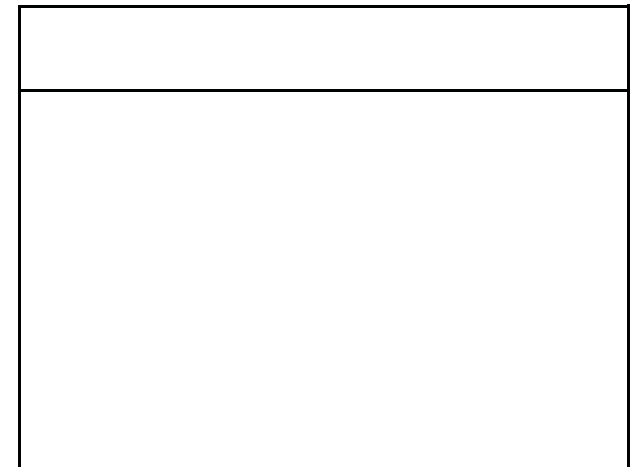

WiFi Menu(DLNA)



After power on, wait until the above display appears.

Select DLNA.

When 'DLNA' is selected, the user shall be shown below figure.

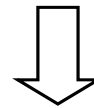
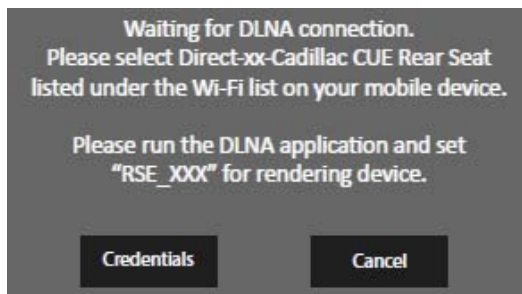

User turns on DLNA and selects a file .

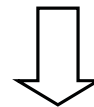
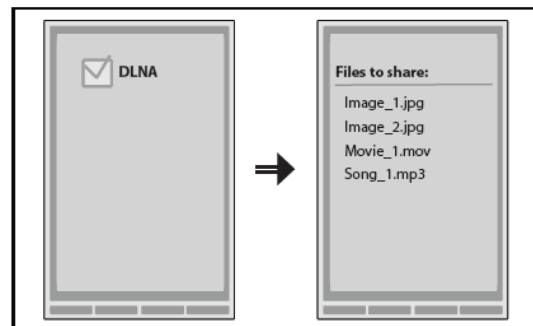

File is shown on RSE



Just the 1st connection, select 'Credentials'. When 'Credentials' is selected, the user shall be shown left figure.

Input passphrase on user's device. If Wi-Fi connection is established, the user may initiate DLNA through their mobile device. Left figure will be shown.

Once successfully connected via WiFi or WiFi-Direct below figure will be shown after selecting 'DLNA'.

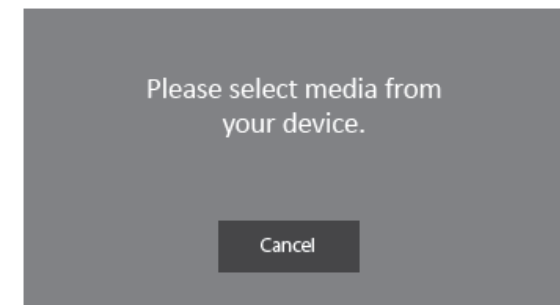

WiFi Menu(Miracast)

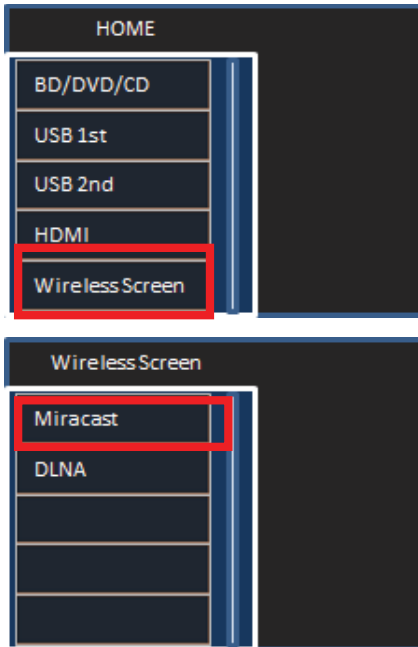

After power on, wait until the above display appears.

Select Miracast.

When 'Miracast' is selected, the user shall be shown below figure.



Initiating the connection on the users device to Miracast will take them through one of the connection methods outlined below. Pressing cancel from this screen will take the user back to the Mobile Device Settings. Depending on the device, one of the following connection methods will be used.

- 1) Push Button Configuration
- 2) Display Method
- 3) Keypad



In the case of a simple connection, on the BD-1G and confirmed on the device, the user will see the screen shown above figure.

In the case of a Display Method Connection, the BD-1G Module will display a popup showing a PIN # and requesting the user to enter the PIN # as shown below figure. If entered correctly, the device will begin screening.

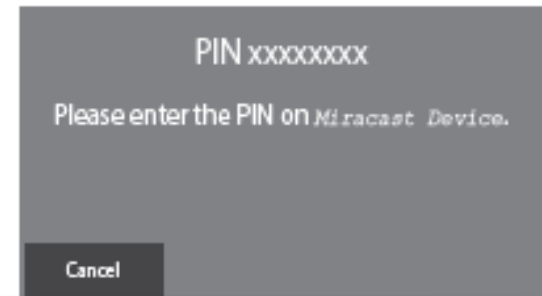

Battery Replacement

To change the batteries:

1. Loosen the screw to the battery door on the left side of the headphones.
2. Slide the battery door open.
3. Replace the two AAA batteries.
4. Replace the battery door and tighten the screw.

Remove the batteries if the headphones will not be used for a long time.

Auxiliary Inputs

Audio/Video (A/V) Jacks

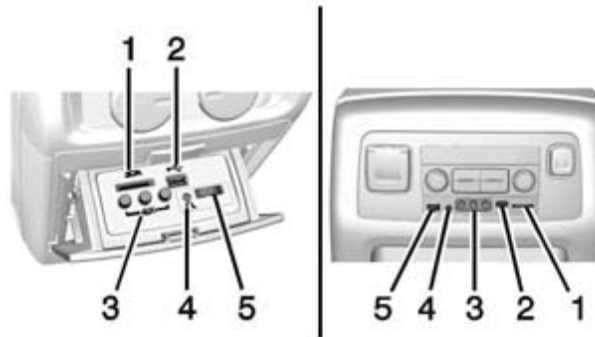

Rear Media Connections (As Equipped)

1. HDMI
2. USB Port
3. A/V Jacks
4. Wired Headphone Jack
5. Volume Control

If equipped with RSE, an HDMI (1), a USB port (2), A/V input jacks (3), wired headphone jack (4), and a volume control (5) will be inside the rear storage area of the center console.

The A/V jacks allow audio or video cables to be connected from an auxiliary device such as a camcorder or video game system.

The A/V jacks are color coded:

- Yellow for video input
- White for left audio input
- Red for right audio input

Power for the auxiliary devices is not supplied by the infotainment system.

To use the auxiliary inputs of the RSE system:

1. Connect the auxiliary device cables to the A/V jacks.
2. Power on both the auxiliary device and the RSE video screen.

USB

This allows for video and audio playback of supported media.

To use the USB:

1. Insert the device in the appropriate slot.
2. Select the source via the rear screen menu with the remote control MEDIA button.
3. Select the source via the front by pressing on the Video application on the home screen.

Audio Output

Audio from a Blu-ray/DVD/CD player or auxiliary inputs can be heard through:

- Wireless headphones
- Vehicle speakers
- Vehicle wired headphone jack

The RSE system transmits the audio signal to the wireless headphones if an audio signal is available. See “Headphones” earlier in this section.

Wired Headphone Jack

Audio from the wired headphone jack can be heard from the desired source through the MENU button on the remote and by selecting Settings, then Headphones. The headphone audio is selected based on the audio associated with screen 1 or screen 2.

The front seat passengers are able to listen to playback from the A/V jacks through the vehicle speakers by selecting Rear A/V as the source on the radio.

Remote Control

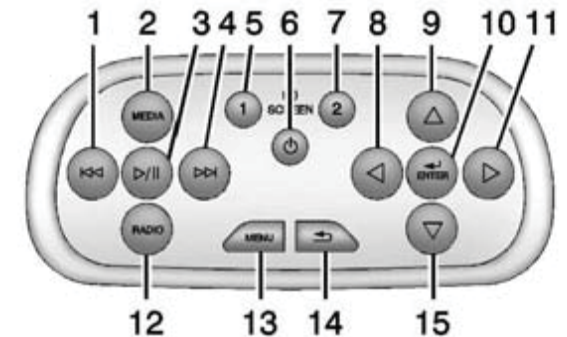

Remote Control Buttons

1.  (Previous/Reverse)
 - Radio: Press to seek the previous radio station.
 - CD: Press to seek the previous track.
 - Blu-ray/DVD: Press to seek the previous chapter.
 - Press and hold for fast reverse.
2. MEDIA
 - Press to scroll through the menus including: CD, AUX, Blu-ray/DVD, HDMI, USB.

3 (Play/Pause)

- Press to start playing. Press to pause. Press again to continue playing.

4. (Next/Fast Forward)

- Radio: Press to seek the next radio station.
- CD: Press to seek the next track.
- Blu-ray/DVD: Press to seek the next chapter.
- Press and hold to fast forward.

5. SCREEN 1

- For dual seatback screens:
Press to select the left screen. Once pressed, all remote control commands will only pertain to screen 1.

- For single overhead screens:

Press to change the source displayed on the overhead screen to SCREEN 1 selected source. Select audio sources. Only one video can be played on the screen at a time. Audio for both sources will continue on the headphones. Once pressed, all remote control commands will correspond to SCREEN 1.

- For dual overhead screens:
Press to select the second row overhead screen. Once pressed, all remote control commands will correspond to SCREEN 1.

6. (Power)

- Press to turn the video screens on and off.

7. SCREEN 2

- For dual seatback screens:
Press to select the right screen. Once pressed, all remote control commands will only pertain to SCREEN 2.
- For single overhead screens:
Press to change the source displayed on the overhead screen to SCREEN 2 selected source. Only one video can be played on the screen at a time. Audio for both sources will continue on the headphones. Once pressed, all remote control commands will correspond to SCREEN 2.
- For dual overhead screens:
Press to select the optional third row overhead screen. Once pressed, all remote control commands will correspond to SCREEN 2.

8.  (Previous/Reverse/Decrease)

- Radio and CD: Press to go to the previous station or track.
- Press to go to the previous menu.
- Press to decrease the brightness of the RSE screen.

9.  (Up Arrow)

- Press to scroll up a list.

10.  /ENTER

- Press to select the highlighted choice in any menu.
- Press and hold for quick play.

11.  (Next/Forward/Increase)

- Radio and CD: Press to go to the next station or track.

- Press to go to the next menu.
- Press to increase the brightness of the RSE screen.

12. RADIO

- Press to scroll through the radio sources including AM, FM, or XM (if equipped).

13. MENU

- Press to go to the menu of the now playing screen.

14.  (Back)

- Press to go back to the previous menu.
- Press and hold to go back to the now playing screen.

15.  (Down Arrow)

- Press to go down a list.

To use the remote control, aim it at the transmitter window at either seatback console or at the second row overhead screen and press the buttons firmly. Direct sunlight or very bright light could affect the ability of the RSE transmitter to receive signals from the remote control. Check the batteries if the remote control does not seem to be working. See “Battery Replacement” later in this section. Objects blocking the line of sight could also affect the function of the remote control.

{ Caution

Storing the remote control in a hot area or in direct sunlight can damage it, and the repairs will not be covered by the warranty. Storage in extreme cold can weaken the batteries. Keep the remote control stored in a cool, dry place.

Battery Replacement

To change the remote control batteries:

1. Insert a coin or key to pull up the rear cover on the remote control.
2. Replace the two AAA batteries in the compartment.
3. Replace the battery cover.

Remove the batteries from the remote control if it will not be used for an extended period of time.

RSE Troubleshooting

No power: The ignition might not be in ON/RUN or ACC/ACCESSORY.

The picture does not fill the screen. There are black borders on the top and bottom or on both sides or it looks stretched out: Press the MENU button on the remote control to change the display mode setting.

In auxiliary mode, the picture moves or scrolls: Check the auxiliary input connections at both devices.

The remote control does not work: Check to make sure the remote control is programmed to the correct screen. Make sure there is no obstruction between the remote control and the transmitter window and check the batteries to make sure they are not dead or installed incorrectly.

There is no sound from the headphones with the indicator light on: If the batteries are good, make sure the headphones are programmed to the correct screen and on the correct channel for the screen being viewed.

The auxiliary source is running but there is no picture or sound: Check that the RSE video screen is in the auxiliary source mode by pressing the MEDIA button on the remote control. Check the auxiliary input connections at both devices.

Sometimes the wireless headphone audio cuts out or buzzes: Check for obstructions, low batteries, reception range, and interference from cell phone towers or from cellular telephone use in the vehicle. Check that the headphones are on correctly using the L (Left) and R (Right) on the headphones. Check that the headphones are positioned properly with the headband across the top of the head.

I lost the remote and/or the headphones: See your dealer for assistance.

The Blu-ray/DVD is playing, but there is no picture or sound: Check that the RSE video screen is sourced to the Blu-ray/DVD player by pressing the MEDIA button on the remote control.