

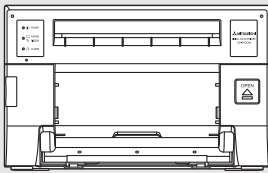

DIGITAL COLOR PRINTER
MODEL

CP-D70DW
CP-D707DW
OPERATION MANUAL



CP-D70D

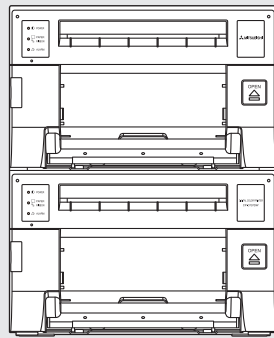

CP-D707D

THIS OPERATION MANUAL IS IMPORTANT
TO YOU.
PLEASE READ IT BEFORE USING YOUR
DIGITAL COLOR PRINTER.



DIGITAL COLOR PRINTER

Hereby, Mitsubishi Electric Corporation, declares that this digital color printer is in compliance with the essential requirements and other relevant provisions of Directive 1999/5/EC.

INFORMATION



This Class A digital apparatus complies with Canadian ICES-003.

WARNING :

TO PREVENT FIRE OR SHOCK HAZARD, DO NOT EXPOSE THIS APPLIANCE TO RAIN OR MOISTURE.

WARNING:

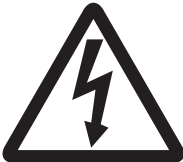
Use the included AC power cord so as not to interfere with radio and television reception. If you use other cables, it may cause interference with radio and television reception.

	CAUTION RISK OF ELECTRIC SHOCK DO NOT OPEN	
<p>CAUTION : TO REDUCE THE RISK OF ELECTRIC SHOCK, DO NOT REMOVE COVER (OR BACK) NO USER-SERVICEABLE PARTS INSIDE REFER SERVICING TO QUALIFIED SERVICE PERSONNEL.</p>		

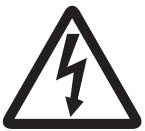

The lightning flash with arrowhead symbol, within an equilateral triangle, is intended to alert the user to the presence of uninsulated “dangerous voltage” within the product’s enclosure that may be of sufficient magnitude to constitute the risk of electric shock.



The exclamation point within an equilateral triangle is intended to alert the user to the presence of important operating and maintenance (servicing) instructions in the literature accompanying the appliance.



The “Caution, hot surface” symbol indicates that the marked item may be hot and should not be touched.



The “Electro Static Discharge (ESD) warning” symbol indicates that trouble (including equipment malfunction) due to static electricity may occur in certain conditions.



The “OFF/ON” symbol indicates connection to or disconnection from the mains, at least for mains switches.



The “Alternating current” symbol indicates that the equipment is suitable for alternating current only.

PRECAUTIONS

FEATURES

CONNECTIONS

PREPARATION

TROUBLE-SHOOTING

OTHERS

CONTENTS

CAUTION:

Changes or modifications not expressly approved by the party responsible for compliance could void the user's authority to operate the equipment.

NOTE:

This equipment has been tested and found to comply with the limits for a Class A digital device, pursuant to Part 15 of the FCC Rules. These limits are designed to provide reasonable protection against harmful interference when the equipment is operated in a commercial environment. This equipment generates, uses, and can radiate radio frequency energy and, if not installed and used in accordance with the instruction manual, may cause harmful interference to radio communications. Operation of this equipment in a residential area is likely to cause harmful interference in which case the user will be required to correct the interference at his or her own expense.

Operation is subject to the following two conditions;

- (1) this device may not cause interference, and
- (2) this device must accept any interference, including interference that may cause undesired operation of the device.

WARNING:

In the USA or Canada, use the AC power cord according to the recommendations as below, in order to comply with UL60950-1 and CAN/CSA C22.2 No. 60950-1-03. Connect to the 120 V receptacle of the room or the host equipment.

The AC power cord should be UL or CSA approved and consist of type SVT, size 16 or 18AWG, length 2 m or shorter cord with IEC60320-1/C13 type, 125 V 10 A or higher rating connector and NEMA 5-15 type, 125 V 10 A or higher rating plug.

Use the AC power cord as specified above, so as not to interfere with radio and television reception.

If you use other cables, it may cause interference with radio and television reception.

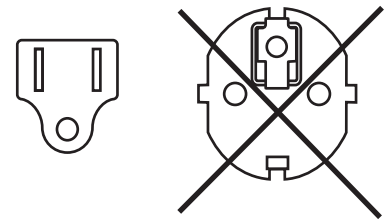

WARNING:

In Europe, use the AC power cord according to the recommendations as below, in order to comply with EN60950-1.

Connect to the 230 V receptacle of the room or the host equipment.

The AC power cord should be VDE approved and consist of core size 1 mm² or bigger, length 2 m or shorter cord with IEC60320-1/C13 type, 250 V 10 A or higher rating connector and CEE(7)VII type, 250 V 10 A or higher rating plug.

Use the AC power cord as specified above, so as not to interfere with radio and television reception.

If you use other cables, it may cause interference with radio and television reception.

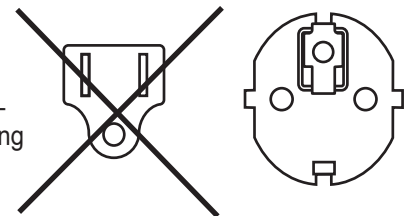

WARNING:

The socket outlet shall be installed near the equipment and shall be easily accessible.

Note: This symbol mark is for EU countries only.

This symbol mark is according to the directive 2002/96/EC Article 10 Information for users and Annex IV, and/or to the directive 2006/66/EC Article 20 Information for end-users and Annex II.



Your MITSUBISHI ELECTRIC product is designed and manufactured with high quality materials and components which can be recycled and/or reused.

This symbol means that electrical and electronic equipment, batteries and accumulators, at their end-of-life, should be disposed of separately from your household waste.

If a chemical symbol is printed beneath the symbol shown above, this chemical symbol means that the battery or accumulator contains a heavy metal at a certain concentration. This will be indicated as follows:

Hg: mercury (0,0005%), Cd: cadmium (0,002%), Pb: lead (0,004%)

In the European Union there are separate collection systems for used electrical and electronic products, batteries and accumulators.

Please, dispose of this equipment, batteries and accumulators correctly at your local community waste collection/recycling centre.

Please, help us to conserve the environment we live in!

CONTENTS

CONTENTS

Contents	1
Safety precautions	2-4
Special features	5
Unpacking	6
Features and functions	7-8
Front panel	7
Side and rear panel	8
Connections	9-10
Connection with USB data signal equipment	9
Setting of DIP switches	10
Before operation	11-17
Installation of print paper	11-12
Positioning of adjustable paper guide	13
Installation of ink ribbon	14-15
Handling of paper / ink ribbon set	16
Installation of printer driver	17
Error messages and countermeasures	18-20
Indications on the front panel and countermeasures	18
Overcoming paper jams	19
Before calling for service	20
Instructions for transportation	20
Cleaning	21-22
Specifications	23

PRECAUTIONS

FEATURES

CONNECTIONS

PREPARATION

TROUBLE-
SHOOTING

OTHERS

CONTENTS

SAFETY PRECAUTIONS

In the interest of safety, please observe the following precautions:

POWER REQUIREMENT

This Digital Color Printer is designed to operate on 120 V AC 50/60 Hz in the U.S.A. and Canada, and 220 V - 240 V AC 50/60 Hz in Europe. Never connect to any outlet or power supply having a different voltage or frequency.

WARNING : THIS APPARATUS MUST BE EARTHED.

PROTECTIVE MEASURES

IF ABNORMALITIES ARISE,

Use of the unit during emission of smoke or abnormal sounds (without adopting countermeasures) is dangerous. In such a case, unplug the power cord from the source outlet immediately, and request maintenance service from the sales dealer.

NEVER INSERT ANY OBJECT INTO THE UNIT

Foreign objects of any kind inserted into this unit constitute a safety hazard and can cause extensive damage.

DO NOT PLACE ANYTHING ON THE DIGITAL COLOR PRINTER

Heavy objects placed on the Digital Color Printer can cause damage or obstruct proper ventilation.

PROTECT THE POWER CORD

Damage to the power cord may cause fire or shock hazard. When unplugging, hold by the plug only and remove carefully.

DO NOT PLACE WATER CONTAINERS ON THE UNIT

Do not place flower vases, and other water-holding containers on the device. If, for some reason, water seeps to the inside of the unit, unplug the power cord from the source outlet, and contact the sales dealer. If used without corrective measures, the unit may be damaged.

“In the interest of safety, avoid handling of liquids near the unit.”

DO NOT REMOVE THE CABINET

Touching internal parts is dangerous, besides, it may lead to malfunction. Contact the sales dealer to carry out internal checks and adjustments. Before opening the cover for eliminating a jammed paper, etc., be sure to disconnect the power cord plug.

UNPLUG THE POWER CORD DURING A LONG ABSENCE

Turn off the main power switch and unplug the power cord during a long absence.

WHEN TRANSPORTING THE UNIT

When transporting the unit, remove the ink ribbon and print paper from the unit. See “INSTRUCTIONS FOR TRANSPORTATION” on page 20.

BE CAREFUL AROUND PRINT PAPER EXIT SLOT

Don't insert your hand or any material into the paper exit slot during printing.

Do not touch the cutter blade inside the paper exit slot.

Otherwise, your finger will be injured.

DO NOT TOUCH THE THERMAL HEAD

Do not touch the thermal head (located inside the unit).

They are heated to high temperature and may cause burns or injury when touched.

Also, malfunction caused by static electricity may occur.

WHEN PLACING THE PRINT PAPER, KEEP THE PRINT PAPER UPRIGHT

When you put the print paper sideways on a table, etc., it may roll and fall. This may cause injury.

CONNECTION CABLES

Use the provided power cord.

PRECAUTIONS

FEATURES

CONNECTIONS

PREPARATION

TROUBLE-
SHOOTING

OTHERS

CONTENTS

SAFETY PRECAUTIONS

REMOVE THE PAPER STRIP BIN WHEN OPENING OR CLOSING THE DOOR

When you open or close the door with the paper strip bin installed, the bin may be removed and fall. This may cause injury or damage. Also, the chips generated by margin cut may jam at the paper exit slot.

DO NOT LEAVE THE PRINTING UNIT OPEN

When the printer is moved with the printing unit open, it may cause injury or damage.

CLOSE THE PRINTING UNIT FIRMLY

Take care not to pinch your hand when closing the printing unit. When the printing unit is not closed firmly, it may open during transportation and it may cause injury or damage.

DO NOT PUSH DOWN ON THE PRINTING UNIT OR THE DOOR

If you push down on the printing unit or the door when they are open, this unit may fall and it can cause damage or injury.

INSTALLATION LOCATIONS

MAINTAIN GOOD VENTILATION

Ventilation slots and holes are provided on the rear and both sides of this unit. Place the unit on a hard and level surface and keep a space between the unit and the walls to ensure proper ventilation. When putting the unit on the system rack, take a space between the unit and the back and sides of the rack.

SUITABLE LOCATIONS

Avoid shaky places or hot-springs areas where hydrogen sulfide and acidic ions are likely to be generated.

AVOID PLACES WITH HIGH HUMIDITY AND DUST

Do not place the unit at a high humidity and dusty locations. They can cause extensive damage to this unit. Avoid places where the unit is likely to be exposed to oily fumes and vapors.

AVOID PLACES LIKELY TO BE EXTREMELY HOT

Places exposed to direct sunlight, or near heating appliances can attain extremely high temperatures, which may deform the cabinet, or can become a prime cause of damage.

PLACES THE UNIT ON A HORIZONTAL LEVEL

The unit is likely to be affected if it is placed in slanted conditions or in an unstable places.

PROTECT AGAINST DEW FORMATION

In extremely cold regions, if the unit is moved quickly from an extremely cold place to warmer one, dew is likely to be formed. If dew is formed, printing is not possible.

OPERATING AMBIENT TEMPERATURE RANGE

The operating ambient temperature range is 5°C - 40°C (41°F - 104°F) and the humidity of 30% - 80% RH. When using the unit on the system rack, be sure to keep this ambient temperature inside the rack.

When the printer is used in a low temperature, it may take some time to start printing.

FOR LONG OPERATING LIFE

UNSUITABLE MATERIALS FOR THE DIGITAL COLOR PRINTER

Coat flaking and deformation are likely to occur if the unit is wiped with chemical dusters, benzene, thinner or any other solvent, if rubber or PVC items are left in contact with the unit for extended duration, or if the unit is sprayed with insecticide.

CARE OF THE CABINET

Unplug and clean with a soft cloth slightly moistened with a mild soap and water solution. Allow to dry completely before operating. Never use petroleum base solutions or abrasive cleaners.

HEAD ABRASION

The thermal head, like the video head, wears out. When it is abraded, it becomes hard to print out fine details of the picture. In such a case, it is necessary to replace the thermal head. Consult with the sales dealer for replacing the head.

CONNECTING DEVICES

Read thoroughly "Operating Precautions" of the instruction booklets for the devices connected with the Digital Color Printer. The power cord must be disconnected after printing is over.

CAUTION ON RELOCATING

When transporting this unit, make sure it is not likely to be subjected to impacts. They can be a prime cause for damage. Further, make sure to disconnect the power cord from the power outlet, and the cables from the connected devices.

PRECAUTIONS

FEATURES

CONNECTIONS

PREPARATION

TROUBLE-
SHOOTING

OTHERS

CONTENTS

SAFETY PRECAUTIONS

OTHER CAUTIONS

- Do not pull out nor touch the print paper until printing is completed. It may degrade the print quality or cause an error.
- Dust or other foreign matter adhering to the print paper or the ink cassette, or deformation resulting from exposure to extremely low or high temperatures could cause loss of color, uneven color or lines, or wrinkles in the print images.
- Depending on the internal temperature, the printer may stop printing temporarily during printing. (The POWER indicator blinks green.) Please wait for the printer to resume printing.
Do not touch the print paper.
- Each time printing is completed, remove the prints. If the prints are not removed, a paper jam may occur.

NOTE:
YOUR UNDERSTANDING IS REQUESTED FOR THE LOSS OF IMAGES IN MEMORY DUE TO THE SUDDEN OCCURRENCE OF A MALFUNCTION.

Cautions to prevent the printer from falling

CAUTION

Falling this printer due to shock or other reasons may cause injury.
For your safety, make sure to secure the printer by the following procedure when you decide the location of installation of the printer.

1. Secure the securing band (supplied) to the printer with the screw (supplied).
2. Secure the other side of the securing band to the installation location with the flat-head screw (supplied).

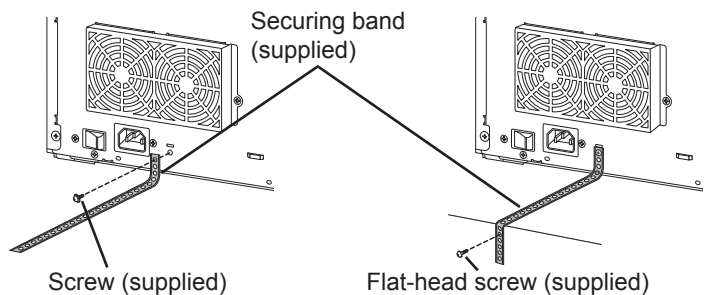

SPECIAL FEATURES

SPECIAL FEATURES

4 PRINT SIZES ARE AVAILABLE DEPENDING ON THE PURPOSE

4 printing sizes, 9x13 (3.5x5") (max. 89 x 127 mm), 10x15 (4x6") (max. 102 x 152 mm), 13x18 (5x7") (max. 127 x 178 mm) and 15x20 (6x8") (max. 152 x 203 mm), are selectable.

300 DPI HIGH RESOLUTION

CP-D70DW and CP-D707DW have a high resolution of 300 dpi for precise illustrations and sharp photographic images.

LARGE CAPACITY PRINTING

Maximum of 450 prints per roll for 9x13 (3.5x5") is offered (CP-D70DW). Large economical print capacity per roll reduces frequency of exchanging paper and ink ribbon.

HIGH QUALITY PRINTING

CP-D70DW and CP-D707DW are dye sublimation thermal transfer color printers, which produce superior high quality images. They also produce a continuous tone at 256 gradient for each of Y, M, and C and 16.7 million colors.

HIGH SPEED PRINTING

Normal printing speed is approx. 8 seconds (in 9x13 (3.5x5") CP-D70DW). Use of roll paper shortens the time for installing and removing.

DOUBLE-DECK SYSTEM (CP-D707DW)

When you print 9x13 (3.5x5")-size paper with both of the upper and lower decks at a time, this printer is capable of high-speed printing at XX seconds for 900 prints.

HI-SPEED USB (VER. 2.0) INTERFACE SUPPORTING

PRECAUTIONS

FEATURES

CONNECTIONS

PREPARATION

TROUBLE-
SHOOTING

OTHERS

CONTENTS

UNPACKING

UNPACKING

Take the printer out of the box by the following procedures. Make sure to check the accessories.

- 1 Open the top of the box and remove the accessories together with the cushion.**
Remove the protective cardboard and then take the accessories out of the cushion.

- 2 Pull the printer up carefully to take it out of the box.**
Pull the printer straight up as shown in the figure.

NOTE
This printer is about 12 kg (CP-D70DW) or about 22 kg (CP-D707DW) in weight. Handle them with care.
When pulling out or transporting CP-D707DW, make sure to do with two persons.

- 3 Unwrap the packing.**
When moving this printer, remove the paper strip bin and then hold the upper front part and the handle on the rear side.
Remove the protective materials for transportation such as protective sheet.

CAUTION
Do not transport the printer by holding the part under the paper strip bin. The paper strip bin may be removed and fall. It may cause injury or damage.

CP-D70DW

CP-D707DW

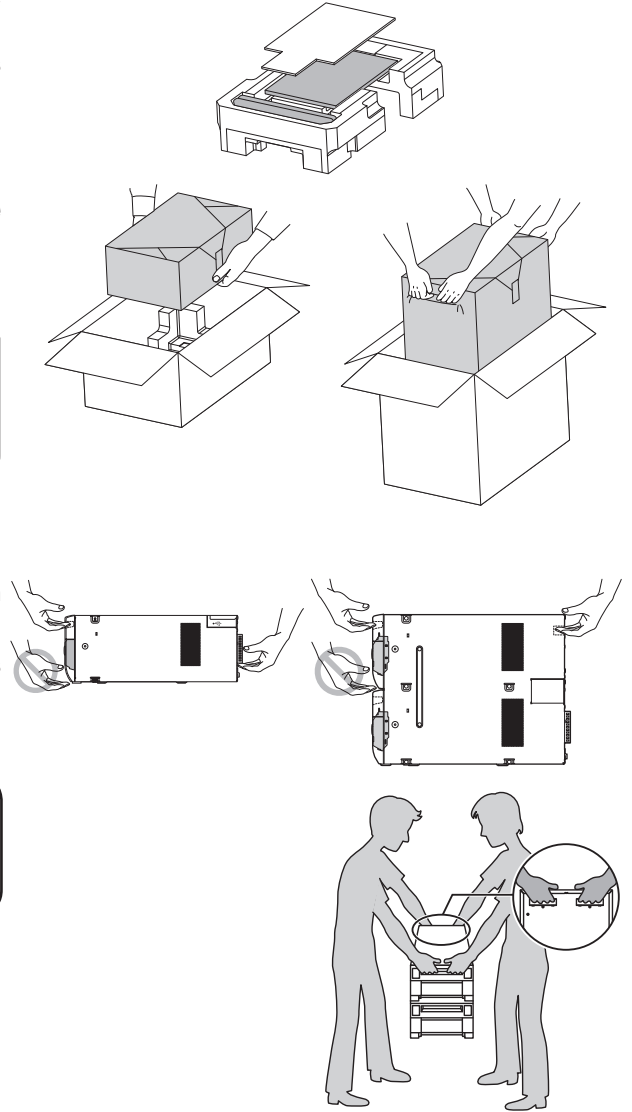

CONTENTS

The accessories are contained in the upper cushions. Check the contents.

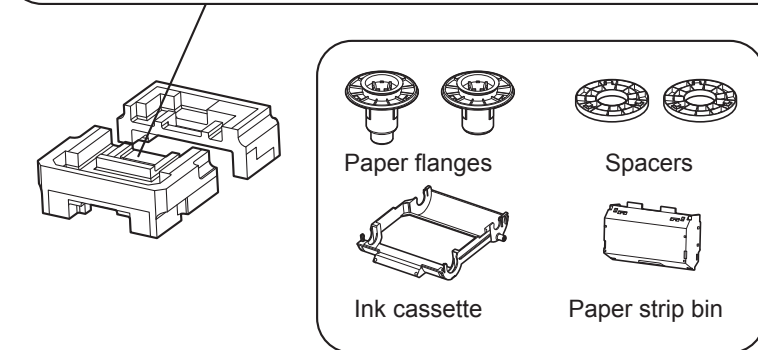
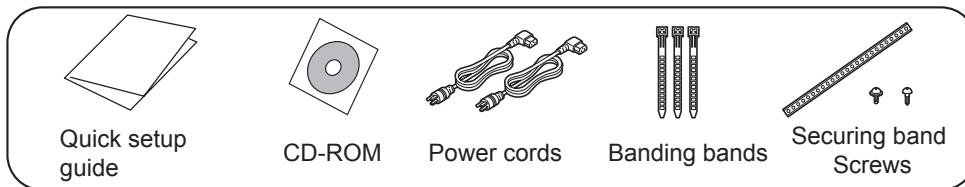

Make sure to remove the protective materials from the ink cassette and paper flanges.

These are contained in the printer.

PRECAUTIONS

FEATURES

CONNECTIONS

PREPARATION

TROUBLE-SHOOTING

OTHERS

CONTENTS

FEATURES AND FUNCTIONS

FRONT PANEL

CP-D70DW

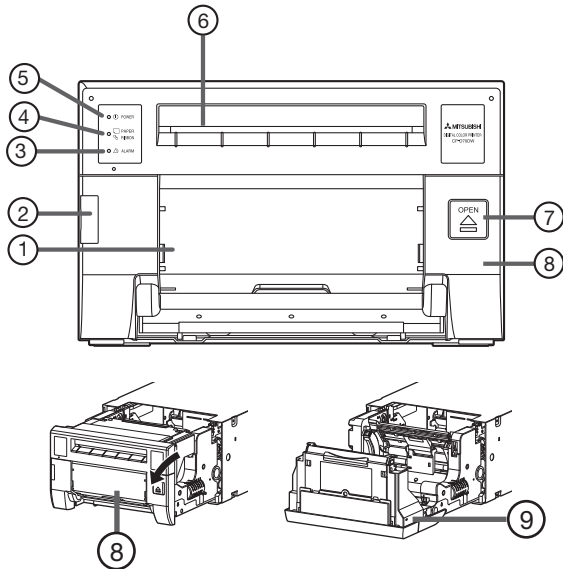

① PAPER STRIP BIN

Holds the paper chips generated by margin cut. To prevent jamming the chips at the print outlet, throw away the chips frequently.

NOTE

Remove the bin before opening the door. If the door is opened with this bin attached, the printer or this bin may be damaged. Do not remove the bin during printing. It may cause a malfunction.

② CONNECTOR COVER FOR OPTIONAL PARTS

Do not open the cover for normal use.

③ ALARM INDICATOR (Δ)

This indicator illuminates or blinks when a paper jam occurs or the door is open. See page 18.

CP-D707DW

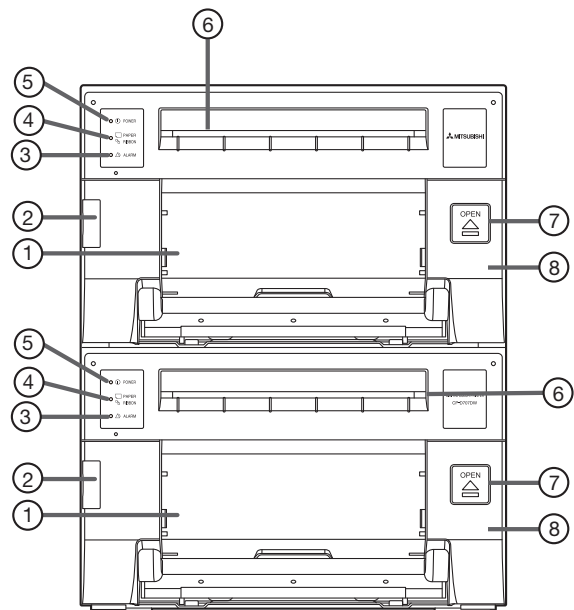

④ PAPER RIBBON INDICATOR (□/%)

When an error concerning the ink ribbon or print paper occurs, this indicator illuminates or blinks. See page 18.

⑤ POWER INDICATOR (Ⓞ)

When the power is turned on, the indicator illuminates. xXXXX. See page 18.

⑥ PRINT OUTLET

The printed paper comes out here.

⑦ OPEN BUTTON (t)

Press this button to pull out the printing unit.

⑧ PRINTING UNIT

Open this unit to mount print paper or ink ribbon. Press the ⑦ OPEN button to open the printing unit. See page 18.

⑨ DOOR

Open the door to mount print paper.

PAPER STRIP BIN

Hook the paper strip bin by its latches.

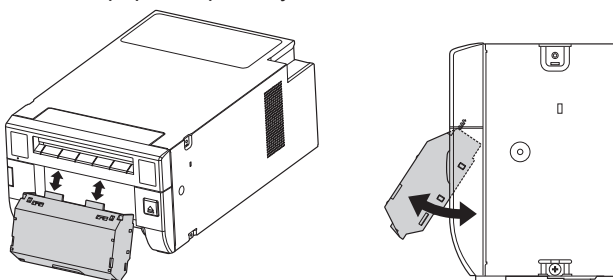

OPENING THE DOOR

Pull out the printing unit by pressing the OPEN button and then pull the knob to open the door.

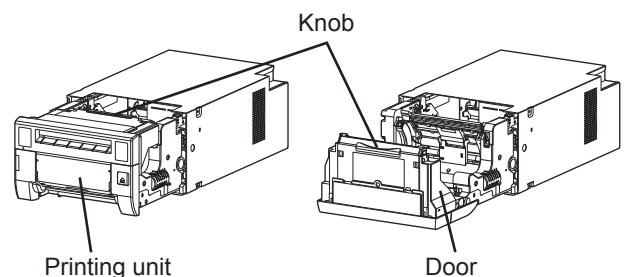

PRECAUTIONS

FEATURES

CONNECTIONS

PREPARATION

TROUBLE-SHOOTING

OTHERS

CONTENTS

REAR PANEL

CP-D70DW

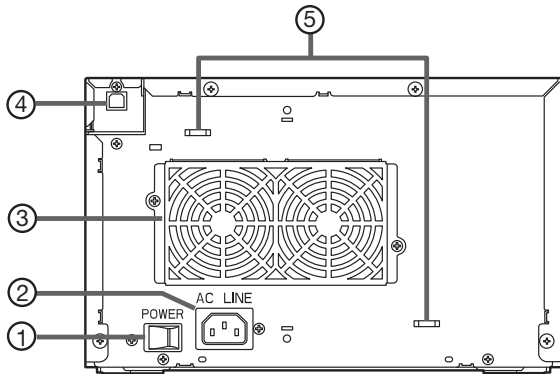

CP-D707DW

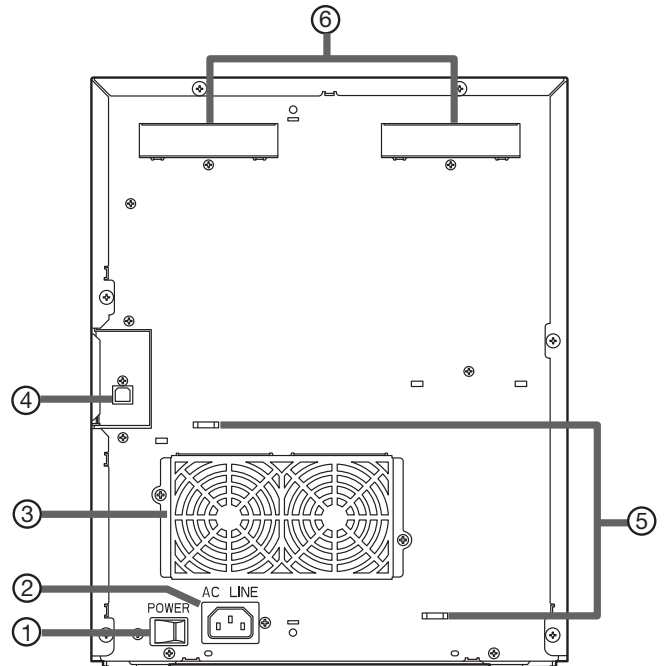

① POWER SWITCH

Use to switch the power ON and OFF.

② POWER SOCKET (AC LINE)

Use to connect the provided power cord. Insert the cord firmly.

③ FAN COVER / HANDLE FOR TRANSPORTING (CP-D70DW)

When transporting this unit, hold this handle and the upper front part of this unit.

④ USB TERMINAL

Use to connect the USB cable.

[See page 9.](#)

⑤ SECURING HOLES FOR THE BANDING BAND

Use to secure the power cord or USB cable by using the banding bands (supplied).

⑥ HANDLE FOR TRANSPORTING (CP-D707DW)

When transporting this unit, hold this handle and the upper front part of this unit.

SECURING THE POWER CORD AND USB CABLE

1. Wrap a banding band (supplied) around the power cord or the USB cable.
2. Draw the band through the securing hole on the rear panel and secure it.

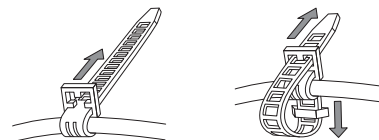
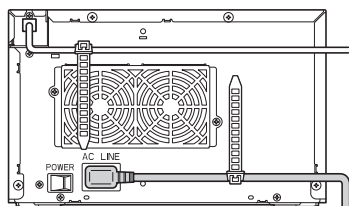

(Example)



BEFORE OPERATION

PREPARARION PROCEDUER

Before printing, make a preparation of the printer by the following procedure.

1. Position the adjustable paper guides. (See page 10.)

2. Install the print paper to this printer. (See pages 11 to 12.)

3. Install the ink ribbon to this printer. (See pages 13 to 14.)

4. Connect this printer with a personal computer. (See page 15.)

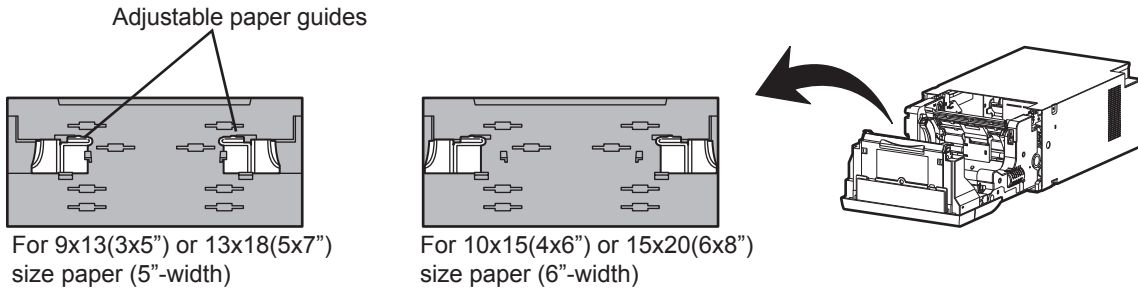
PRECAUTIONS
FEATURES
CONNECTIONS
PREPARATION
TROUBLE-SHOOTING
OTHERS
CONTENTS

POSITIONING OF ADJUSTABLE PAPER GUIDE

Adjust the paper guides according to the size of print paper to be used.



■ HOW TO SHIFT THE ADJUSTABLE PAPER GUIDES

- 1 Pinch the tab on the adjustable paper guide and slide it right or left.

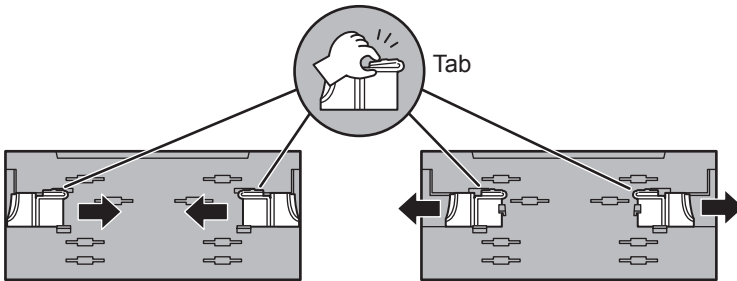

- 2 Slide the paper guide until it stops. The paper guide is fixed to the appropriate position.
- 3 Slide other paper guide in the similar way.

NOTE

- Make sure to adjust the adjustable paper guides according to the size of print paper to be used. When they are not positioned properly, a malfunction such as paper jam and misaligned printing position may occur.

PRECAUTIONS
FEATURES
CONNECTIONS
PREPARATION
TROUBLE-SHOOTING
OTHERS
CONTENTS

BEFORE OPERATION

INSTALLATION OF PRINT PAPER

Spacers

■ For the usage of the spacers, see the Quick Setup Guide.

How to attach the spacers

1. Attach the spacer with the paper flange's stoppers retracted.
2. Turn the spacer until the latches are locked.

When you remove the spacers from the paper flanges, follow the above procedure in reverse.

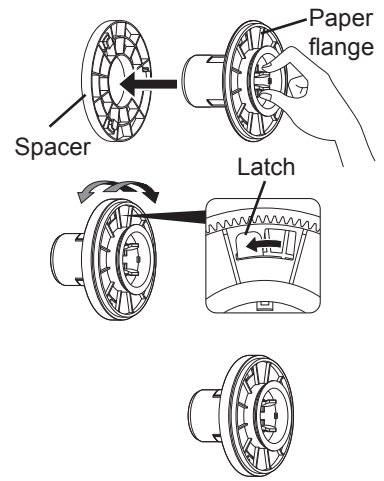

1 Attach the supplied paper flanges to both sides of the print paper.

When you pinch the latches on the paper flange, the stoppers retract into the shaft. Attach the flanges to the print paper with the stoppers retracted.

Make sure that the flanges are attached to the print paper securely, and release the latches.

NOTE

- Take care not to pinch your fingers.
- Do not remove the sticker on the print paper yet.
- Do not slacken the paper. Any slack in the print paper may degrade the print quality.

CAUTION

- When placing the print paper, keep the print paper upright.
- When you put the print paper sideways, it may roll and fall. This may cause injury.

NOTE

- Fingerprints or dust on the paper's surface may degrade print quality and cause paper jams.

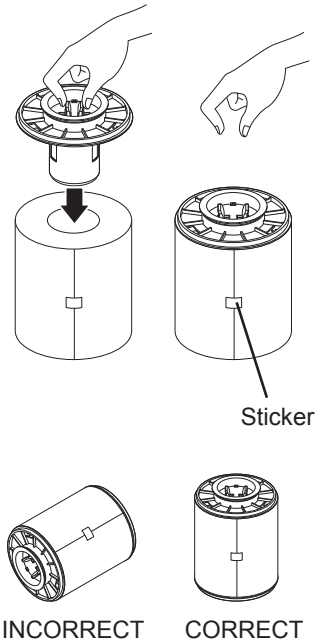

PRECAUTIONS

FEATURES

CONNECTIONS

PREPARATION

TROUBLE-SHOOTING

OTHERS

CONTENTS

BEFORE OPERATION

2 Press the POWER switch on the rear panel to turn on the power.

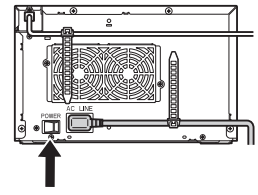

POWER switch

3 After the mechanical initialization is completed, press the OPEN button to pull out the printing unit.

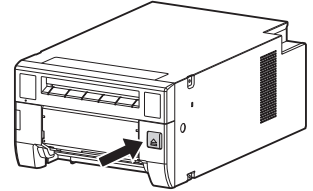

Knob

4 Pull the knob to open the door.

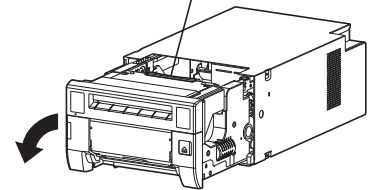

5 Install the print paper into the unit.

Make sure to install the print paper firmly.

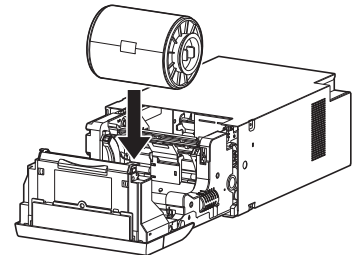

NOTE
Install the print paper into the unit slowly. If it is dropped along the ditches, the unit or accessories may be damaged.

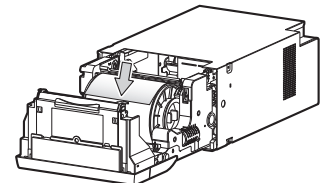
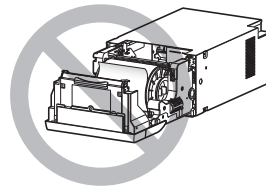

Direction of paper insertion

6 Remove the sticker, insert the print paper between the roller and guide as shown right, and feed the print paper until the buzzer sounds.

- Remove the sticker before inserting the print paper between roller and guide. Make sure to insert the paper straight.

- NOTE**
- Keep the roller clean. Dirt on the roller may degrade the print quality.

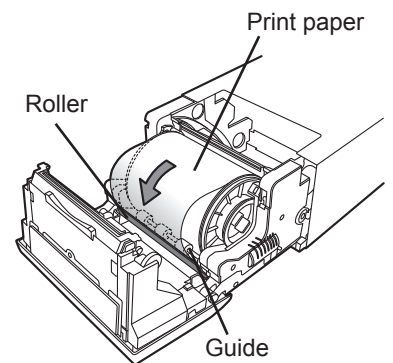

- NOTE**
- When taking the print paper out, pull it up toward you by holding the paper flanges.
 - Make sure to turn on the power before replacing the print paper.
 - Make sure to eliminate any slack from the print paper. If you carry out the following steps without eliminating the slack, the print paper may be damaged.

7 Close the door.

PRECAUTIONS

FEATURES

CONNECTIONS

PREPARATION

TROUBLE-SHOOTING

OTHERS

CONTENTS

BEFORE OPERATION

INSTALLATION OF INK RIBBON

After installing the print paper, install the ink cassette into this unit.
Before installing the ink cassette into this unit, load the ink ribbon in the ink cassette.

NOTE

- Place the ink cassette on a flat surface, when loading the ink ribbon.
- Select a place that is free of dust when loading the ink ribbon. Dust or dirt settling on the ink ribbon results in poor print quality.
- Make sure that the shafts of the ink ribbon fit into the ink cassette firmly.

1 Load the ink ribbon in the ink cassette as shown below.

- Make sure to load it in the correct position.

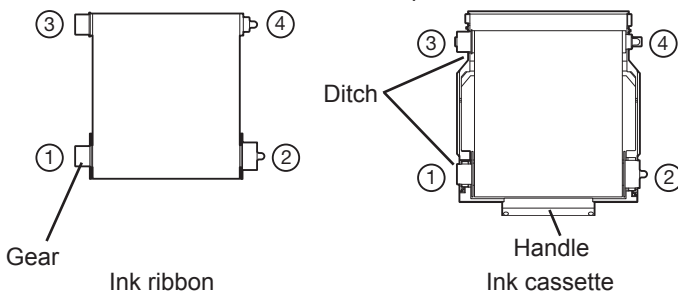

Make sure to set the ink ribbon roller to the ditches firmly.
Turn the gears to eliminate any slack.

2 Place the ink cassette containing the ink ribbon in the position as shown right.

Mount the ink cassette by holding the handle.
Make sure to set the ink cassette to the printer firmly.

CAUTION

- Do not touch the thermal head.
Fingerprints or dust on the thermal head will degrade the print quality.

3 Close the door.

CAUTION



- Do not touch the thermal head right after printing because it is extremely hot. Otherwise you may get burned or injured.

NOTE



- Note that the thermal head is quite sensitive to static electricity. When you touch the thermal head while carrying static electricity on your body, the thermal head may be damaged.

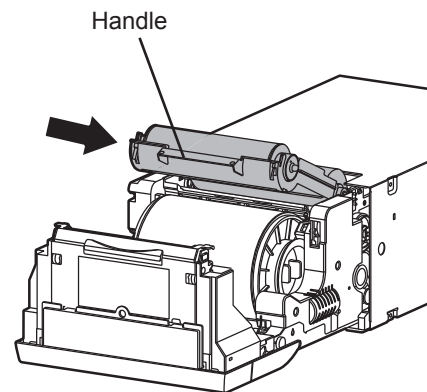

PRECAUTIONS

FEATURES

CONNECTIONS

PREPARATION

TROUBLE-SHOOTING

OTHERS

CONTENTS

BEFORE OPERATION

4 Push the printing unit to close.

When new print paper is mounted and the printing unit is closed with the power turned on, the paper is automatically fed and cut.

NOTE

- When closing the door, push it until a click is heard.
- If the PAPER RIBBON indicator illuminates when the printing unit is closed, the print paper may have not been installed correctly. In this case, open the printing unit to make sure that the print paper has been installed correctly. Then close the printing unit again.
- When the print paper is installed more than three times, the print paper may be used up earlier than the ink ribbon.

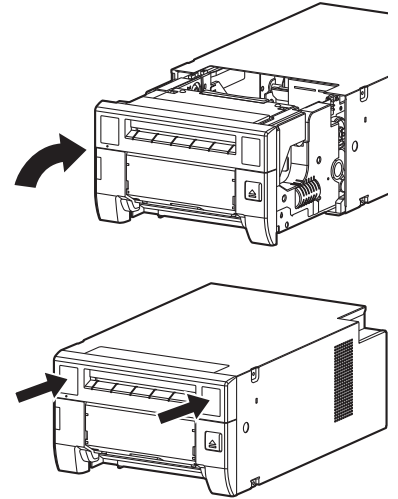

Installation of the print paper and the ink ribbon is completed.

NOTE

- Make sure to replace the print paper and the ink ribbon simultaneously.
- When replacing them, throw away the paper chips in the paper strip bin.
- Whenever you replace the print paper and the ink ribbon, clean the thermal head and the platen roller. For the cleaning procedures, see [“CLEANING”](#) (on pages 21 and 22).

PRECAUTIONS

FEATURES

CONNECTIONS

PREPARATION

TROUBLE-SHOOTING

OTHERS

CONTENTS

HANDLING OF PAPER / INK RIBBON SET

BEFORE PRINTING

- Fingerprints or dust on the paper's printing surface may degrade the print quality and cause paper jams.
- When the print paper or ink ribbon is abruptly transferred from a cool place to a hot place, vapor or dew is generated on the surface, which causes paper jams or degraded print quality. Leave the print paper in the room to stabilize its temperature before use.
- If you repeat the installation of print paper procedure more than the designated number of times, the indicated number of prints may not be made. In addition, if you replace the print paper before it is used up, the indicated number of prints may not be made.

AFTER PRINTING

- If the paper absorbs nonvolatile organic solvents (alcohol, ester, ketone, etc.) the print may be discolored.
- Discoloration of prints is accelerated if the print paper comes into contact with soft vinyl chloride such as transparent tape.
- Avoid storing prints in direct sunlight or places with high humidity.

STORAGE OF PAPER / INK RIBBON SET

- Do not store the print paper and ink ribbon in the container made of soft polyvinyl chloride. They may be discolored because of chemical reaction.
- Store the print paper and ink ribbon out of direct sunlight and away from heating appliances in a cool, dark place where the temperature is 5°C to 30°C and the humidity is 20% to 60% RH.

PRECAUTIONS

FEATURES

CONNECTIONS

PREPARATION

TROUBLE-SHOOTING

OTHERS

CONTENTS

BEFORE OPERATION

CONNECTION WITH USB DATA SIGNAL EQUIPMENT

CONNECTING TO PERSONAL COMPUTER (EXAMPLE)

- 1 Turn on the power of a personal computer.
- 2 Turn on the power of the printer.
- 3 Connect the printer and a personal computer with a USB cable.

Connect the printer to a personal computer as shown below.

NOTE

Do not connect the printer and the personal computer at this step when you use Windows 7 as the operation system.

Refer to the PRINTER DRIVER GUIDE in the CD-ROM for details.

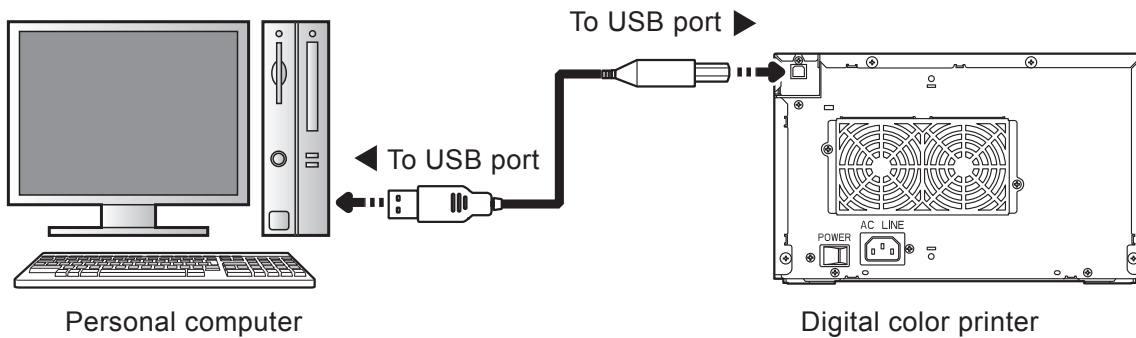

NOTE

A USB cable is not supplied with this unit. Use the USB 2.0 certified cable of 2 m or less in length.

INSTALLATION OF PRINTER DRIVER

- The printer driver is required to print the data from the personal computer connected with this unit. The printer driver for Windows® is supplied with this unit.

Product name	Required operating system
CPD70X	Applies for Microsoft Windows® XP operation system
CPD70V	Applies for Windows Vista® and Windows 7™ operation system

- Refer to the PRINTER DRIVER GUIDE in the CD-ROM for installing the printer driver.

Microsoft, Windows, Windows XP, Windows Vista and Windows 7 are the trademarks or the registered trademarks of Microsoft Corporation in the U.S.A. and other countries.

ERROR MESSAGES AND COUNTERMEASURES

INDICATIONS ON THE FRONT PANEL AND COUNTERMEASURES

■ If, for some reason, printing is not possible or an error occurs during printing, the indicators on the front panel will illuminate or blink. In this case, follow the procedure described below.
 In case of an error during printing, unless you turn off the unit, the unit resumes printing automatically when the error is corrected.

☾: Steady on ●: Off ☾●: Blinking

ALARM	PAPER RIBBON	POWER	Causes and Countermeasures	Page
●	●	☾ (Orange)	This printer is in standby mode. Connect a USB cable to the printer when not connected. It may take time that the printer is ready to print images after the image data is sent.	7
☾●	●	☾ (Green)	The printing unit is open. • Close the printing unit.	7
☾●	☾●	☾ (Green)	A paper jam occurs. • Refer to "Overcoming paper jams."	19
●	●	☾● (Green)	The temperature of the thermal head is too high or too low. • Wait until the indication goes off. When blinking stops, the printer resumes printing automatically.	7
●	☾●	☾ (Green)	The ink ribbon which is not available to this printer is installed. • Replace the ink ribbon with a new one. The actual combination of ink ribbon and print paper is inconsistent with the setting made by the personal computer. • Open the printing unit and confirm that the actual combination of ink ribbon and print paper is consistent with the setting made by the personal computer. After checking, close the printing unit.	14-15
●	☾	☾ (Green)	The print paper or ink ribbon is not installed. The print paper or ink ribbon is used up. • Install new print paper or ink ribbon.	11-12
☾	●	☾ (Green)	Other errors	20

When the ALARM or the PAPER RIBBON indicator illuminates or blinks, open the door and carry out the above countermeasures.

PRECAUTIONS

FEATURES

CONNECTIONS

PREPARATION

TROUBLE-SHOOTING

OTHERS

CONTENTS

OVERCOMING PAPER JAMS

- 1 Press the OPEN button to open the printing unit.**
Make sure that the power is turned on before opening the printing unit.

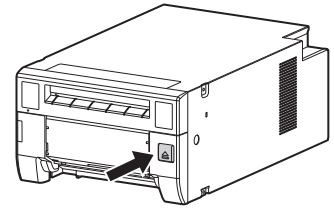

- 2 Remove the ink cassette.**

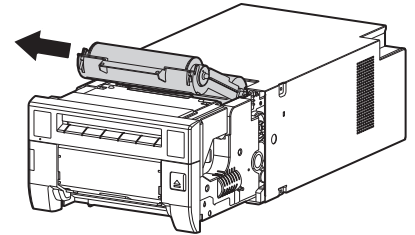

- 3 Open the door.**

- 4 Pull out the defective part of the print paper to the direction of an arrow.**

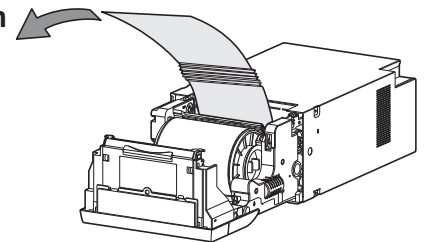

- 5 Cut off the defective part of the print paper with scissors.**

NOTE

- Make sure to cut off the printed part of the print paper. Failure to do this may result in the ink ribbon sticking to the print paper and being torn.
- Make sure to clean the thermal head and the platen roller. [Refer to "CLEANING" \(on pages 21 and 22\).](#)

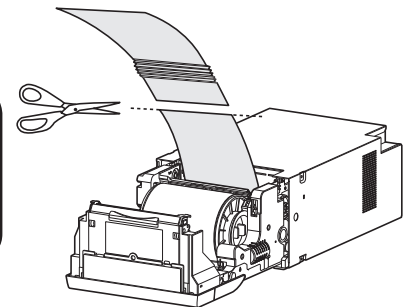

- 6 Install the print paper and the ink cassette with the ink ribbon.**
[\(Refer to pages 11-15.\)](#)

- 7 Close the door.**

- 8 Close the printing unit by pushing it.**

ERROR MESSAGES AND COUNTERMEASURES

PRECAUTIONS

FEATURES

CONNECTIONS

PREPARATION

TRUBLE-SHOOTING

OTHERS

CONTENTS

BEFORE CALLING FOR SERVICE

■ For the following symptoms, check the unit again before calling for service.

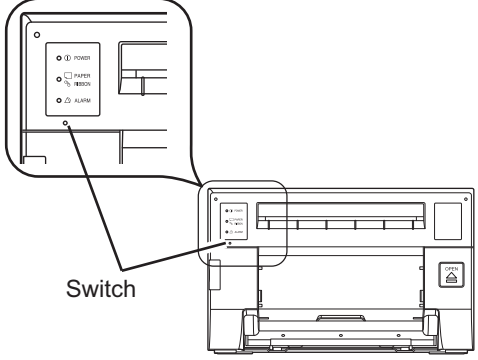
Symptom	Check & Remedy
The power is not turned on.	<p>Is the power cord plug disconnected from the outlet?</p> <p>→ Connect the power cord plug to the outlet firmly.</p> <p>→ The protective circuit may be working. Turn off the power and wait for about two minutes. Then turn on the power again.</p>
The printing unit doesn't open.	<p>Are you turning off the power during printing procedure?</p> <p>→ Turn on the power and then open the printing unit.</p>
The image is not printed.	<p>Is the PAPER RIBBON indicator or the ALARM indicator illuminating or blinking?</p> <p>→ Refer to "Overcoming paper jams."</p> <p>Is the appropriate size of data sent to this unit?</p> <p>→ Make sure that the appropriate size of image data is sent to this unit.</p> <p>Is the print paper or the ink ribbon used up?</p> <p>→ Check them.</p> <p>Is the printing unit set firmly?</p> <p>→ Set the printing unit firmly.</p>
An error can not be resolved.	<p>→ Turn off and on the power of the printer with the printing unit set firmly. This printer starts initialization. Press the switch inside of the hole of the front panel with a thin stick or the like for one second or more.</p>  <p>Switch</p>

INSTRUCTIONS FOR TRANSPORTATION

When transporting this unit for some reason such as repair, follow the instructions below.

1. Use the original packaging.

The genuine package unit may not endure more than one round trip. If the unit is transported with the package unit more than one round trip, it may not be guaranteed.

Purchase another package unit when transporting this unit again.

Pack the unit with the accessories (ink ribbon and print paper) removed.

2. Close the printing unit firmly.

When closing the printing unit, push it until a click is heard.

3. If the ink ribbon, print paper, or ink cassette can not be taken out, consult with your dealer.

CLEANING

Cleaning as indicated below will help maintain stable printer operation and extend the printer's life.

Make sure to turn off the power before cleaning.

FILTER CLEANING

Clean the filter part with a vacuum as shown right.

THERMAL HEAD CLEANING

1 Press the OPEN button to open the printing unit.

2 Take the ink cassette out of the printer.

Preparations

Alcohol (isopropyl alcohol)

Soft and clean cloth

Other : Cleaner pen (option)*, Cleaning ribbon (option)*

* Please ask the dealer about options.

When lines appear on the printed images, clean the thermal head.

Wipe the head cleaning part (as shown right) carefully with cloth dampened with a small amount of alcohol.

NOTE

- Do not damage the thermal head.
- When the poor print quality is not corrected even if the head has been cleaned, replacement of the thermal head may be required. Contact your dealer.

CAUTION



- Thermal head is hot right after printing. Wait until the head cools before cleaning the thermal head.

NOTE



- The thermal head may be damaged if you touch it while static electricity builds up on your body.

Filter (inside)

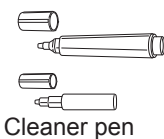
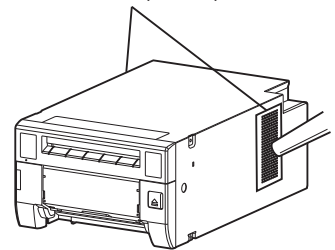

Cleaner pen

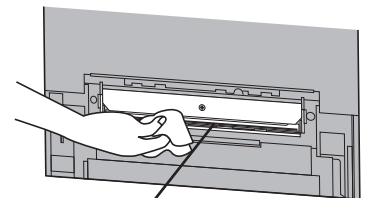

Cleaning part of thermal head

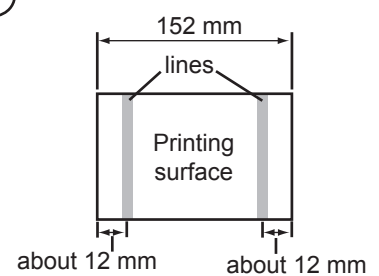
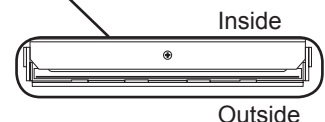

PRECAUTIONS

FEATURES

CONNECTIONS

PREPARATION

TROUBLE-
SHOOTING

OTHERS

CONTENTS

CLEANING

PLATEN ROLLER CLEANING

Preparations

- Alcohol (isopropyl alcohol)
- Soft and clean cloth

- Clean the black part of the roller.
- Wipe the black part carefully with cloth dampened with a small amount of alcohol.
- Wipe the whole roller by turning it.

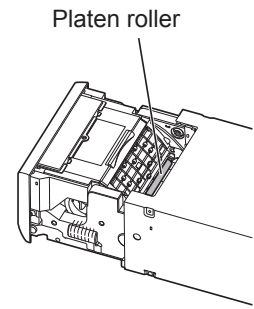

PAPER FLANGE CLEANING

- Clean the parts that contact the print paper sides as shown right.
- Wipe the parts carefully with cloth dampened with a small amount of alcohol.

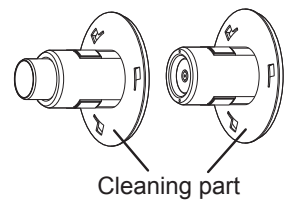

PRECAUTIONS
FEATURES
CONNECTIONS
PREPARATION
TROUBLE-SHOOTING
OTHERS
CONTENTS

SPECIFICATIONS

SPECIFICATIONS		
Class	Digital Color Printer	
Model	CP-D70DW	CP-D707DW
Printing method	Sublimation Dye Thermal Transfer line print 3-color faces progressive printing (yellow, magenta, and cyan) and surface lamination	
Print's resolution	300 x 300 dpi (dpi : dots per inch)	
Dot resolution	9x13 (3.5x5") 10x15 (4x6") 13x18 (5x7") 15x20 (6x8")	1076 x 1568 dots 1228 x 1864 dots 1568 x 2128 dots 1864 x 2422 dots
Print size	9x13 (3.5x5") 10x15 (4x6") 13x18 (5x7") 15x20 (6x8")	89 x 127mm (without frame) 102 x 152mm (without frame) 127 x 178mm (without frame) 152 x 203mm (without frame)
Gradations	256 (8 bits) for each color (About 16.7 million colors)	
Printing time	9x13 (3.5x5") 10x15 (4x6") 13x18 (5x7") 15x20 (6x8")	Approx. 8 sec./sheet Approx. 8 sec./sheet Approx. 16 sec./sheet Approx. 18 sec./sheet
Supply method	Automatic	
Interface	Hi-Speed USB (Ver.2.0)	
Power supply	220 - 240 V AC 50/60 Hz, 120 V AC 50/60 Hz	
Power consumption	2.5 A (220 - 240 V AC, 50/60 Hz), 4.7 A (120 V AC, 50/60 Hz) during printing 0.4 A (220 - 240 V AC, 50/60 Hz), 0.4 A (120 V AC, 50/60 Hz) when not printing	
Operating conditions	Temperature : 5°C - 40°C Humidity : 30% - 80% RH (no dewing)	
Installation conditions	Operating attitude : Horizontal ±5°	
Outside dimensions	275(W) x 446(D) x 170(H) mm	275(W) x 446(D) x 340(H) mm
Weight	Approx. 12 kg (excluding accessories)	Approx. 22 kg (excluding accessories)
Standard accessories	Power cords (for 120 V and 230 V), Ink cassette (1), CD-ROM (1), Paper flange (1 set), Spacers (2), Quick setup guide (1), Paper strip bin (1), Banding band (3), Securing band (1), Screw for securing band (2)	Power cords (for 120 V and 230 V), Ink cassette (2), CD-ROM (1), Paper flange (2 sets), Spacers (4), Quick setup guide (1), Paper strip bin (2), Banding band (3), Securing band (1), Screw for securing band (2)

Design and specifications are subject to change without notice.

■ Contents of CD-ROM

- Operation manual
- Printer driver
- PRINTER DRIVER GUIDE

PRECAUTIONS
FEATURES
CONNECTIONS
PREPARATION
TROUBLE-SHOOTING
OTHERS
CONTENTS



MITSUBISHI DIGITAL ELECTRONICS AMERICA, INC.

9351 Jeronimo Road, Irvine, CA 92618, U.S.A.

Phone 949-465-6000

MITSUBISHI ELECTRIC EUROPE B.V.

UK Branch

Travellers Lane, Hatfield, Herts. AL10 8XB, England, U.K.

Phone +44 (0) 1707 276100 FAX +44 (0) 1707 278755

German Branch

Gothaer Strasse 8, 40880 Ratingen ; Postfach 1548, 40835 Ratingen ; Germany

Phone +49 (2102) 486-9250 FAX +49 (2102) 486-7320

French Branch

25, Boulevard des Bouvets - 92741 NANTERRE cedex, France

Phone +33 (1) 55 68 55 00 FAX +33 (1) 55 68 57 31

Italian Branch

Centro Direzionale Colleoni, Palazzo Sirio, ingresso n.1

Viale Colleoni, 7, 20041 Agrate Brianza, (Milano) Italy

Phone +39 03960531 FAX +39 0396053214

Benelux Branch

Nijverheidsweg 23a,

3641 RP Mijdrecht, The Netherlands

Phone +31 (0) 297-282461 FAX +31 (0) 297-283936

Spanish Branch (Barcelona)

Ctra. de Rubí, 76-80 - Apdo. 420

08190-Sant Cugat del Vallés - (Barcelona) Spain

Phone +34 93 565 3154 FAX +34 93 589 4388

Please contact the nearest Mitsubishi sales branch to get DOC (Declaration of Conformity) of the EC Directive 1999/5/EC.

Manufactured by Mitsubishi Electric (Malaysia) Sdn. Bhd.
PLO 32, Kawasan Perindustrian Senai II, 81400 Senai, Johor Darul Takzim, Malaysia