

# VIDEO CASSETTE RECORDER OWNER'S GUIDE



## MODEL HS-U776



As an ENERGY STAR® Partner, Mitsubishi Digital Electronics America, Inc. has determined that this product or product model meets the ENERGY STAR® guidelines for energy efficiency.



VCR Plus+® and PlusCode® are registered trademarks of Gemstar Development Corporation. The VCR Plus+ system is manufactured under license from Gemstar Development Corporation.

With VCR Plus+C<sup>3</sup>® system, this video cassette recorder can automatically select the appropriate channel on your compatible cable box or satellite receiver. C<sup>3</sup> and VCR Plus+C<sup>3</sup>® are trademarks of Gemstar Development Corporation.



This Video Cassette Recorder is based on the S-VHS and VHS formats. Only video cassette tapes with the **S-VHS** mark or the **VHS** mark may be used with this model.

## Special Features HS-U776

### SMART:

- ◆ Program Conflict Warning
- ◆ S-VHS and S-VHS ET record/playback
- ◆ VHS Hi-Fi audio record/playback
- ◆ VCR Plus+® C3 with cable converter control
- ◆ Satellite Receiver Control

### FAST:

- ◆ Alfa 400 Precision High Speed Mechanism with 400x rewind/fast forward speed

### EASY:

- ◆ ViewPoint® Menu Operating System
- ◆ VCR Plus+® easy programming system
- ◆ OTR<sup>2</sup> Advanced One Touch Recording with delayed start time
- ◆ Auto Clock Set
- ◆ Active AV Network™

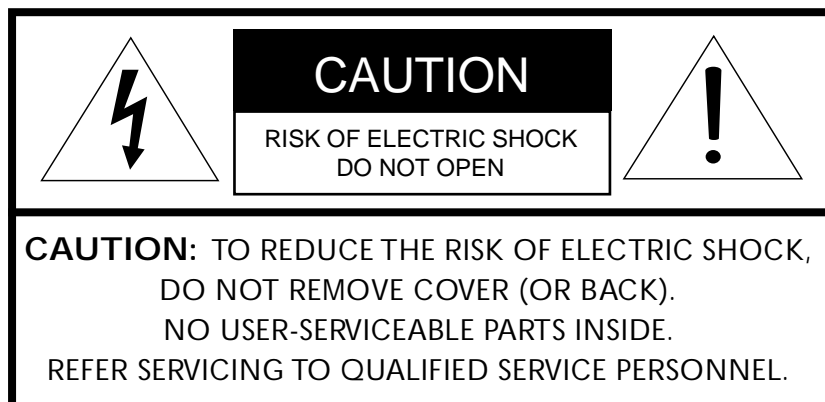

The lightning flash with arrowhead symbol, within an equilateral triangle, is intended to alert the user to the presence of uninsulated "dangerous voltage" within the product's enclosure that may be of sufficient magnitude to constitute a risk of electric shock to persons.



The exclamation point within an equilateral triangle is intended to alert the user to the presence of important operating and maintenance (servicing) instructions in the literature accompanying the product.

### IMPORTANT:

RECORDING OF COPYRIGHTED TELEVISION PROGRAMS MAY VIOLATE COPYRIGHT LAW.

### WARNING:

TO REDUCE THE RISK OF FIRE OR ELECTRIC SHOCK, DO NOT EXPOSE THIS PRODUCT TO RAIN OR MOISTURE.

### CAUTION:

TO PREVENT ELECTRIC SHOCK HAZARD, DO NOT USE THIS (POLARIZED) PLUG WITH AN EXTENSION CORD, RECEPTACLE OR OTHER OUTLET UNLESS THE BLADES CAN BE FULLY INSERTED TO PREVENT BLADE EXPOSURE.

### NOTE TO CATV SYSTEM INSTALLER:

THIS REMINDER IS PROVIDED TO CALL THE CATV SYSTEM INSTALLER'S ATTENTION TO SECTION 820-40 OF THE NEC WHICH PROVIDES GUIDELINES FOR PROPER GROUNDING AND, IN PARTICULAR, SPECIFIES THAT THE CABLE GROUND SHALL BE CONNECTED TO THE GROUNDING SYSTEM OF THE BUILDING, AS CLOSE TO THE POINT OF CABLE ENTRY AS PRACTICAL.

# SHORTCUTS

To **connect** your VCR, go to page 4.

To **play a tape**, go to page 10.

To **record a program**, go to page 21.

To learn about **Advanced Features**, go to page 38.



# TABLE OF CONTENTS

IMPORTANT SAFEGUARDS .....	2	Editing Features .....	36
Hooking Up Your VCR .....	4	Using Two VCRs to Copy .....	36
Playback .....	10	Advanced Features .....	38
Setting Up Your VCR .....	13	Advanced Playback Controls .....	38
Memorizing Channels Automatically ...	13	Searching Techniques .....	40
Satellite Receiver Control .....	15	Using PrograManager .....	42
Adding and Deleting Channels .....	16	Displaying Time Gauge, Remaining	
Setting the Clock .....	18	Time, Current Time .....	47
Recording .....	21	Customize Choices Menu .....	48
Recording a Current Broadcast .....	21	Advanced Options .....	53
OTR .....	22	Location of Controls .....	55
OTR <sup>2</sup> .....	23	Trouble Checks .....	59
Using S-VHS Set-Up Menu .....	24	Specifications .....	61
Audio and Video Functions .....	26	Index .....	61
Timer Recording .....	28	Warranty .....	65
Conventional VCR Timer			
Recording .....	28		
Quick Program .....	30		
VCR Plus+ <sup>®</sup> System			
Programming .....	31		
Timer Recording Hints .....	33		

# IMPORTANT SAFEGUARDS

Please read all these instructions carefully regarding your VCR before you begin operating it. Follow all warnings and instructions marked on the VCR. Thank you.

## 1 Read Instructions

All the safety and operating instructions should be read before the product is operated.

## 2 Retain Instructions

The safety and operating instructions should be retained for future reference.

## 3 Heed Warnings

All warnings on the product and in the operating instructions should be adhered to.

## 4 Follow Instructions

All operating and use instructions should be followed.

## 5 Cleaning

Unplug this product from the wall outlet before cleaning. Do not use liquid cleaners or aerosol cleaners. Use a damp cloth for cleaning.

## 6 Attachments

Do not use attachments not recommended by the product manufacturer as they may cause hazards.

## 7 Water and Moisture

Do not use this product near water — for example, near a bath tub, wash bowl, kitchen sink, laundry tub, in a wet basement, or near a swimming pool, and the like.

## 8 Accessories

Do not place this product on an unstable cart, stand, tripod, bracket, or table. The product may fall, causing serious injury to a child or adult, and serious damage to the product. Use only with a cart, stand, tripod, bracket, or table recommended by the manufacturer, or sold with the product. Any mounting of the product should follow the manufacturer's instructions, and should use a mounting accessory recommended by the manufacturer.

- 9 A product and cart combination should be moved with care. Quick stops, excessive force, and uneven surfaces may cause the product and cart combination to overturn.



## 10 Ventilation

Slots and openings in the cabinet are provided for ventilation and to ensure reliable operation of the product and to protect it from overheating, and these openings must not be blocked or covered. The openings should never be blocked by placing the product on a bed, sofa, rug, or other similar surface. This product should not be placed in a built-in installation such as a bookcase or rack unless proper ventilation is provided or the manufacturer's instructions have been adhered to.

## 11 Power Sources

This product should be operated only from the type of power source indicated on the marking label. If you are not sure of the type of power supply to your home, consult your product dealer or local power company. For products intended to operate from battery power, or other sources, refer to the operating instructions.

## 12 Grounding or Polarization

This product is equipped with a polarized alternating-current line plug (a plug having one blade wider than the other). This plug will fit into the power outlet only one way. This is a safety feature. If you are unable to insert the plug fully into the outlet, try reversing the plug. If the plug should still fail to fit, contact your electrician to replace your obsolete outlet. Do not defeat the safety purpose of the polarized plug.

## 13 Power-Cord Protection

Power-supply cords should be routed so that they are not likely to be walked on or pinched by items placed upon or against them, paying particular attention to cords at plugs, convenience receptacles, and the point where they exit from the product.

## 14 Outdoor Antenna Grounding

If an outside antenna or cable system is connected to the product, be sure the antenna or cable system is grounded so as to provide some protection against voltage surges and built-up static charges.

Article 810 of the National Electrical Code, ANSI/NFPA 70, provides information with regard to proper grounding of the mast and supporting structure, grounding of the lead-in wire to an antenna discharge unit, size of grounding conductors, location of antenna-discharge unit, connection to grounding electrodes, and requirements for the grounding electrode.

EXAMPLE OF ANTENNA GROUNDING

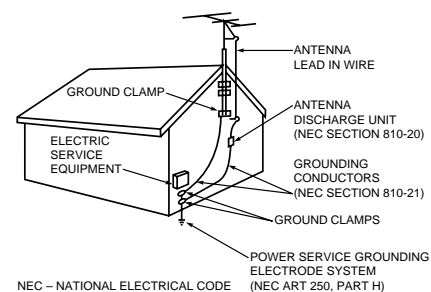

## 15 Lightning

For added protection for this product during a lightning storm, or when it is left unattended and unused for long periods of time, unplug it from the wall outlet and disconnect the antenna or cable system. This will prevent damage to the product due to lightning and power-line surges.

## 16 Power Lines

An outside antenna system should not be located in the vicinity of

overhead power lines or other electric light or power circuits, or where it can fall into such power lines or circuits. When installing an outside antenna system, extreme care should be taken to keep from touching such power lines or circuits as contact with them might be fatal.

### 17 Overloading

Do not overload wall outlets, extension cords, or integral convenience receptacles as this can result in fire risk or electric shock.

### 18 Object and Liquid Entry

Never push objects of any kind into this product through openings as they may touch dangerous voltage points or short-out parts that could result in a fire or electric shock. Never spill liquid of any kind on the product.

### 19 Servicing

Do not attempt to service this product yourself as opening or removing covers may expose you to dangerous voltage or other hazards. Refer all servicing to qualified service personnel.

### 20 Damage Requiring Service

Unplug this product from the wall outlet and refer servicing to qualified service personnel under the following conditions:

- (a) When the power-supply cord or plug is damaged.
- (b) If liquid has been spilled, or objects have fallen into the product.
- (c) If the product has been exposed to rain or water.

(d) If the product does not operate normally by following the operating instructions. Adjust only those controls that are covered by the operating instructions as an improper adjustment of other controls may result in damage and will often require extensive work by a qualified technician to restore the product to its normal operation.

(e) If the product has been dropped or damaged in any way.

(f) When the product exhibits a distinct change in performance – this indicates a need for service.

### 21 Replacement Parts

When replacement parts are required, be sure the service technician has used replacement parts specified by the manufacturer or have the same characteristics as the original part. Unauthorized substitutions may result in fire, electric shock or other hazards.

### 22 Safety Check

Upon completion of any service or repairs to this product, ask the service technician to perform safety checks to determine that the product is in proper operating condition.

### 23 Heat

The product should be situated away from heat sources such as radiators, heat registers, stoves, or other products (including amplifiers) that produce heat.

### CONDENSATION

Leave the VCR on, without a tape in it, for 2 hours if the VCR has been exposed to sudden changes in temperature. Sudden temperature changes cause moisture to form on the metal parts inside the VCR. This moisture can cause the tape to stick and damage the head. Leaving the VCR on for a 2 hour period will dry the inside of the VCR.

### PROTECT THE POWER CORD

Do not damage the power cord. Damage to the power cord may cause a fire or shock hazard. When unplugging the power cord, please hold it by the plug and remove it carefully.

### DO NOT PLACE HEAVY OBJECTS ON THE RECORDER

Heavy objects placed on the recorder will cause damage.

### WHEN NOT IN USE

When you finish operating the recorder, always unload the cassette and turn OFF the VCR POWER.

### CARE OF THE VIDEO CASSETTE TAPES

- Avoid violent vibration or shock.
- Do not place in a location where strong magnetic fields exist (near a motor, transformer or magnet).
- Never place or store in direct sunlight.
- Avoid dusty places.
- Place the cassette in the cassette case and store vertically.
- Never store tape in a high humidity location.

### INFORMATION

This equipment has been tested and found to comply with the limits for a Class B digital device, pursuant to Part 15 of the FCC Rules. These limits are designed to provide reasonable protection against harmful interference in a residential installation. This equipment generates, uses, and can radiate radio frequency energy and, if not installed and used in accordance with the instructions, may cause harmful interference to radio communications. However, there is no guarantee that interference will not occur in a particular installation. If this equipment does cause harmful interference to radio or television reception, which can be determined by turning the equipment off and on, try to correct the interference by one or more of these measures:

- Reorient or relocate the receiving antenna
- Increase the separation between the equipment and receiver
- Connect the equipment into an outlet on a different circuit than the receiver is connected
- Consult the dealer or an experienced radio/TV technician for help

Changes or modifications not expressly approved by the party responsible for compliance could void the user's authority to operate the equipment. If necessary, consult the dealer or an experienced radio/TV technician for additional suggestions. You may find this booklet prepared by the Federal Communications Commission helpful: How to Identify and Resolve Radio-TV Interference Problems. This booklet is available from the US Government Printing Office, Washington, D.C., 20402, Stock No. 004-000-00345-4.

# Hooking Up Your VCR

## Unpacking Your VCR

As you unpack your new VCR, please make sure the following items are included:

- Remote control



- 1 S-Video cable

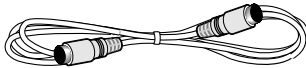

- 1 Audio/Video cable

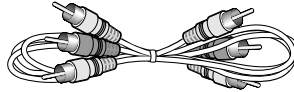

- 1 Coaxial cable

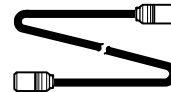

- 1 IR emitter

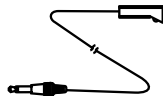

- 2 "AA" size batteries

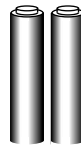

- Registration card



### IMPORTANT

Never place any heavy objects on top of the VCR. Do not place the VCR on top of the television because of its instability.

## Choosing a Hookup

The connections shown in this book are general. Individual televisions, stereo systems and satellite receivers can vary from those shown here. The first diagrams show connections for common equipment. Then, if you are connecting equipment such as a satellite receiver or a Home Theater receiver, you will also use those diagrams after you have connected the common equipment.

### IMPORTANT

To maximize your system for its best performance, your dealer can help you customize these hookups and sell you any additional connection accessories that may be necessary to match your particular equipment and antennas.

- 1 Make a list of each piece of equipment that you want to hook up.
- 2 If you are connecting several pieces of equipment, you may be using more than one of these diagrams. Using your list, find EACH of the diagrams you will need to connect all of your equipment. For example, to hook up this VCR, a TV, a cable box, and a Home Theater receiver, you will use Cable System with Cable Box, and Connecting a Home Theater receiver.
- 3 If your TV has audio and video inputs, use the diagrams on page 6 in addition to the connections on the next page.

## Hooking Up Your VCR

### IMPORTANT

You must use one of the connections shown on this page in order to record television or cable programs.

## Antenna or Cable System without Cable Box

### Connecting Antenna or Cable

- 1 Connect antenna or cable from wall outlet to ANTENNA IN of the VCR.
- 2 Connect VCR ANTENNA OUT to the TV's Antenna jacks (varies by TV).
- 3 If your TV has audio video inputs, continue with the connections on the next page. If not, plug in power cords of VCR and TV.

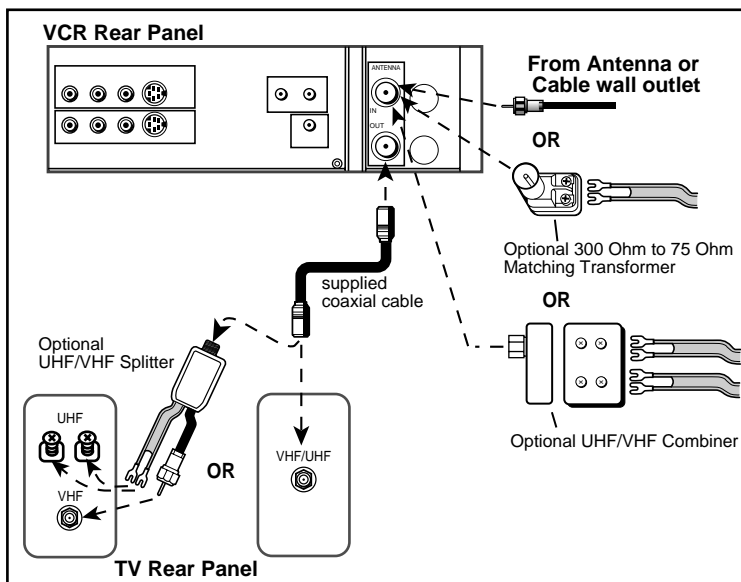

## Cable System with Cable Box

### Connecting Cable and Cable box

- 1 Connect cable from wall outlet to CABLE IN on the cable box.
- 2 Connect OUT (or OUT TO TV) on the cable box to ANTENNA IN on the VCR.
- 3 Connect ANTENNA OUT on the VCR to the TV's antenna jacks (varies by TV).
- 4 If your TV has audio video inputs, continue with the connections on the next page. If not, plug in power cords of VCR, TV, and cable box.
- 5 See page 9 for IR Emitter connection.

If your cable box has audio and video outputs, follow the additional directions below. You may need to purchase additional sets of audio/video cables for this hookup.

- 6 Connect the red and white cable to the AUDIO IN R (right) and AUDIO IN L (left) on the VCR. Connect the other end to the cable box's AUDIO OUT RIGHT and AUDIO OUT LEFT.
- 7 Connect the yellow video cable to VIDEO IN on VCR. Connect the other end to VIDEO OUT on the cable box.

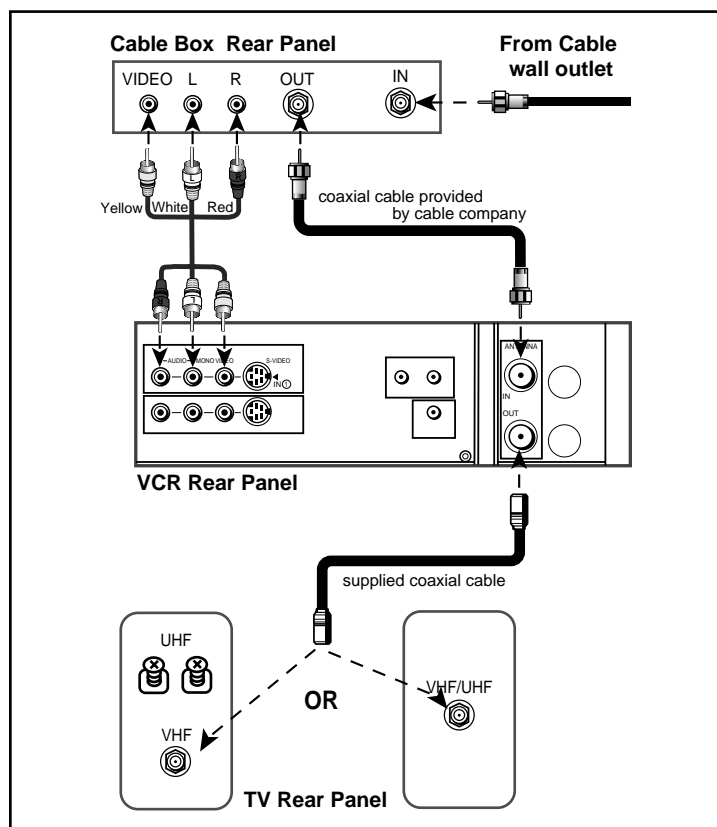

### IMPORTANT

Your TV Owner's Guide may have additional suggestions for antenna/cable hookups.

If your TV has more than one antenna jack, ask your Mitsubishi dealer for advice on additional accessories.

# Hooking Up Your VCR

## Connections to TV with Audio Video Inputs

Because you purchased a Hi-Fi VCR, you will want to take advantage of its superior sound capability and connect it to a stereo TV system with audio and video inputs. This connection also helps maintain the best picture quality.

- 1 Connect the red and white audio cable to AUDIO OUT R (right) and AUDIO OUT L (left) on the VCR. Connect the other end to the TV's AUDIO IN RIGHT and AUDIO IN LEFT. Match the colors of the connectors to the cables.
- 2 Connect the yellow video cable to VIDEO OUT on VCR. Connect the other end to VIDEO IN on the TV.
- 3 To use S-video cable, connect it as shown.
- 4 Set the RF converter to OFF. See page 49 for instructions on this setting, which can be done at a later time.

### IMPORTANT

Your TV Owner's Guide may have additional suggestions for audio video hookups.

To connect your VCR to a mono (non-stereo) TV, connect only the white AUDIO OUT L of the VCR and the white AUDIO INPUT of the TV. Since the TV is not stereo, you cannot take advantage of your VCR's Hi-Fi stereo sound.

If you have an older TV without audio video inputs, simply connect only the antenna or cable as shown on the previous page.

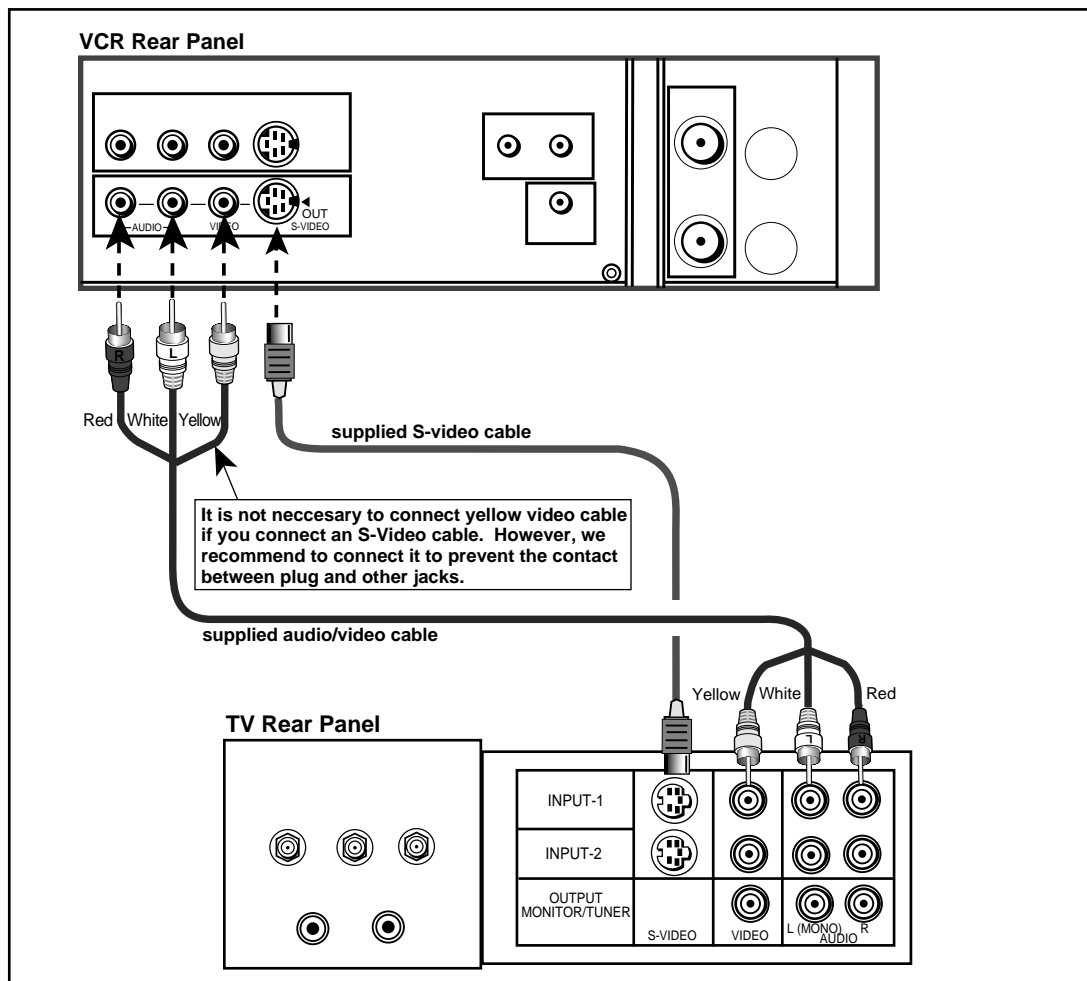



# Hooking Up Your VCR

## Connections to Satellite Receiver

If you have an RCA DSS®, Sony DSS®, Toshiba DSS®, Panasonic DSS®, Hughes DSS®, PRIMESTAR®, or DISH Network™ satellite system, you can connect the satellite receiver to your VCR and then set up the VCR to change the channels of the satellite receiver. This will allow you to program your VCR to make unattended recordings from several different satellite channels.

- 1 Connect the red and white audio cable to AUDIO OUT R and AUDIO OUT L on the satellite receiver. Connect the other end to the AUDIO IN R and AUDIO IN L on the back of the VCR. Match the colors of the connectors to the cables.
- 2 Connect the S-video cable to S-VIDEO OUTPUT on the satellite receiver. Connect the other end to the S-VIDEO IN on the back of the VCR. If your satellite receiver does not have S-VIDEO OUTPUT, connect the video cable to VIDEO OUTPUT on the satellite receiver. Connect the other end to the VIDEO IN on the back of the VCR.
- 3 See page 9 for IR Emitter connection.

### connecting both a satellite receiver and a cable box with audio video outputs

- 1 Connect the satellite receiver to the audio video inputs on the back of the VCR as shown.
- 2 Connect the cable box to the audio video inputs on the front of the VCR.

### IMPORTANT

You cannot connect both a satellite receiver and a digital cable box.

You may need to purchase an audio cable and an S-video cable for this hookup.

If possible, you should have connected your VCR to your TV with an S-Video cable. It will allow you to watch the satellite video signal on your TV even when the VCR is off if you set the Rear S-through in the S-VHS Set-Up menu to ON.

If you connect your VCR to your TV with a standard video cable, you will have to turn the VCR on to watch the video signal from the satellite receiver. You will be able to hear the audio signal from your satellite receiver both when the VCR is on and off.

When you connect a satellite receiver to the S-video input on the back of the VCR, you have to set the Rear S-input in the S-VHS Set-Up menu to ON.

Refer to your Satellite Receiver Owner's Guide for Satellite dish to Satellite receiver connections, as well as other possible video connections to your TV.

DSS® is a registered trademark of DirecTV, Inc.

PRIMESTAR® is a registered servicemark of PRIMESTAR Partners LP.

DISH Network™ is a registered trademark of EchoStar Communications Corp.

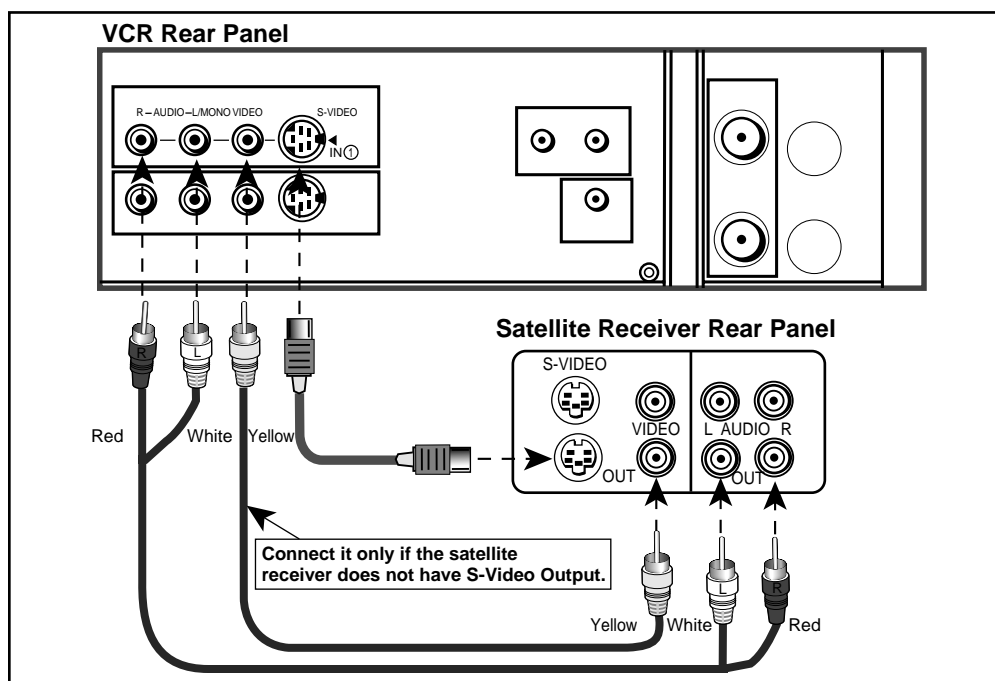

# Hooking Up Your VCR

## Connections to Home Theater Receiver

You may wish to connect your VCR to a Home Theater Receiver so that you can take advantage of the Surround Sound audio recordings that are common with many movies. Home Theater Receivers often will control both the sound that is heard from the speakers and the picture shown on your TV. Below is the basic connection between your VCR and Home Theater Receiver. If you use this connection, you will not use **Connections to TV with AudioVideo Inputs**.

- 1 Connect the red and white audio cables to AUDIO OUT R and AUDIO OUT L on the VCR. Connect the other end to the VCR 1 AUDIO INPUT R and AUDIO INPUT L on the Home Theater Receiver.
- 2 Connect an S-video cable to S-VIDEO OUT on the VCR. Connect the other end to the VCR 1 S-VIDEO INPUT on the Home Theater Receiver.

- 3 Connect an S-video cable to the MONITOR S-VIDEO OUTPUT of the Home Theater Receiver. Connect the other end to the S-VIDEO INPUT on the back of the TV.

### IMPORTANT

If either your Home Theater Receiver or TV does not have S-Video connections, use standard yellow video cables in step 2 and 3.

- 4 See your Home Theater Receiver Owner's Guide for information concerning audio connection between TV and Home Theater Receiver, or additional hookups and operations.

### IMPORTANT

You may need to purchase additional sets of audio video cables for this hookup.

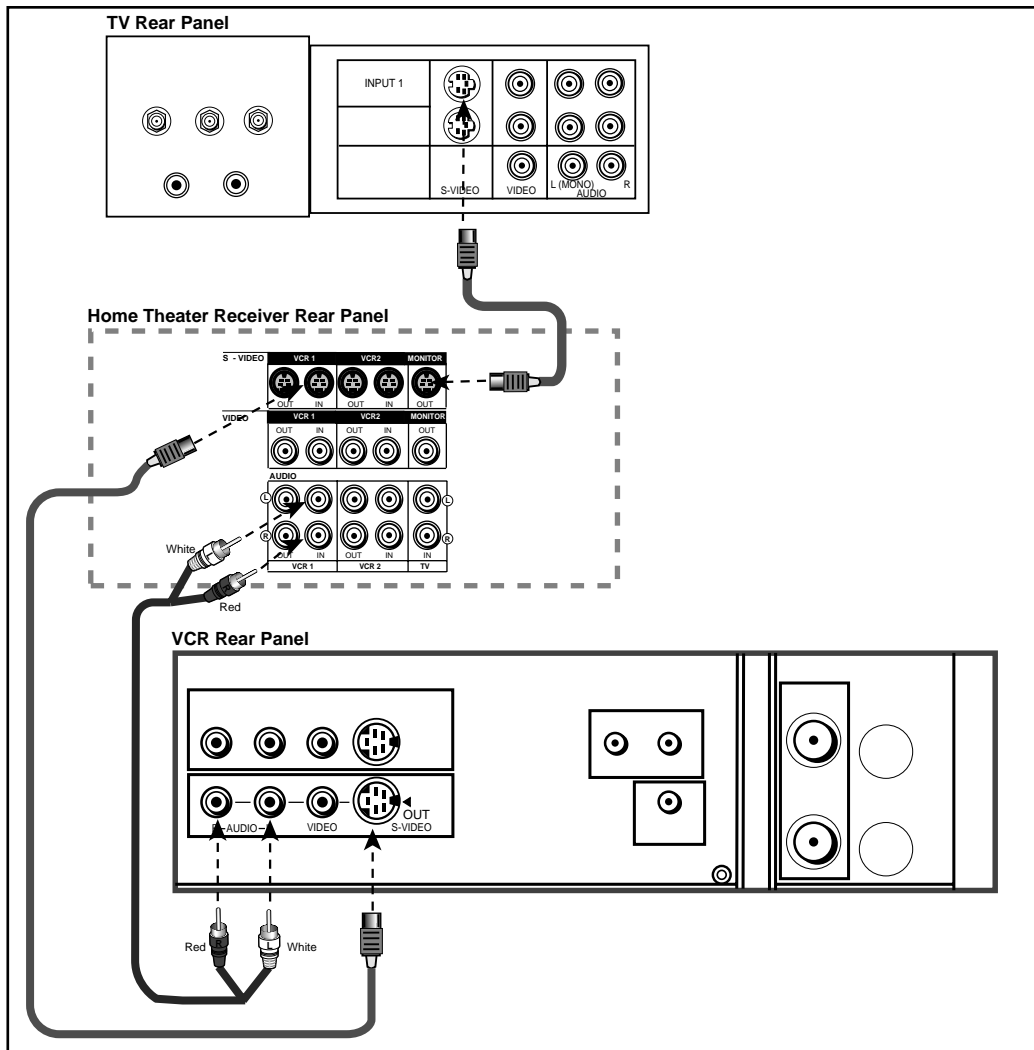

# Hooking Up Your VCR

## Connections to A/V Network

Some Mitsubishi TVs and VCRs have special input and output terminals called the A/V Network. This network "passes" remote control commands between Mitsubishi components. That is, when the A/V Network is connected, you can point your VCR remote control at the TV, and the TV will "pass" the commands onto the VCR.

- 1 You will need a cable with a "mini" jack at both ends. A mini jack is the kind you find on headphones for personal stereos. This cable may be included with your Mitsubishi TV. If not, you can purchase a cable with mini jacks at your Mitsubishi dealer or electronics store.
- 2 Connect ACTIVE A/V NETWORK OUT or A/V NETWORK OUT on the TV to ACTIVE A/V NETWORK IN on the VCR.
- 3 If you have another Mitsubishi component with A/V Network, connect another mini jack cable to ACTIVE A/V NETWORK OUT on the VCR, and connect the other end to (ACTIVE) A/V NETWORK IN on the other component.

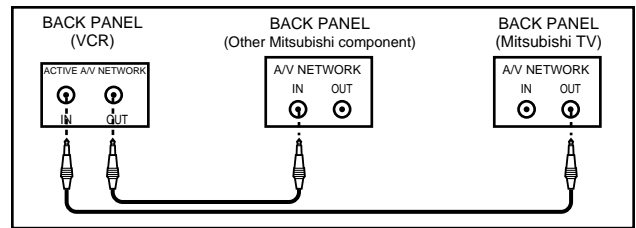

### IMPORTANT

For Active A/V Network to work properly, you must make these connections shown **and** your VCR must be connected to EXT-1 or INPUT-1 of your Mitsubishi TV.

Never connect your A/V Network in a loop, as shown below.

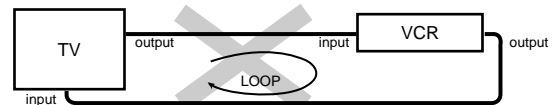

## Connections to IR Emitter

Your VCR will be able to send remote control channel changing commands to your compatible cable box or satellite receiver. The VCR uses the IR Emitter to send these commands in the same way as when you use the hand held remote that came with the cable box or receiver.

- 1 Connect the supplied IR Emitter to CONVERTER BOX CONTROL on back of the VCR.
- 2 Run the wire under or along side the cable box or satellite receiver and place the end in front of the cable box and/or satellite receiver.

- 3 Use the double stick tape to secure the end of the emitter in the proper place.

### IMPORTANT

If you connect both a cable box and satellite receiver, place the IR Emitter to face the remote control window (sensor) in the front of both. If you cannot place it this way, you can purchase a dual IR Emitter from your Mitsubishi dealer.

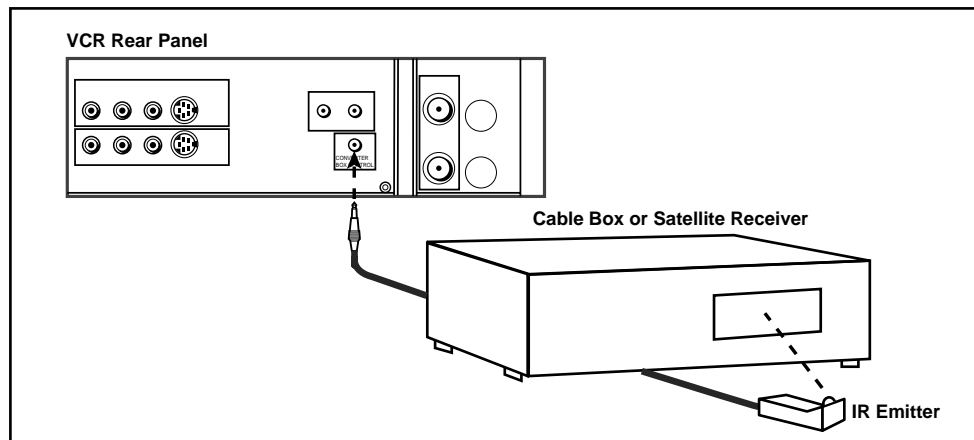

# Playback

## Setting Up Your VCR

The first thing you need to do is set up your VCR so that you can see the picture coming from the VCR. It's important to take a few minutes to set up your VCR correctly before you try to use it. Based on your type of TV, choose one of the following:

### TV with Audio/Video Inputs

- 1 Turn on your TV and switch it to the correct external input. For most Mitsubishi TVs, this means pressing the TV's INPUT button until you see the words **Ext-1** or **Input-1** on the screen. If you do not have a Mitsubishi TV, please refer to your TV Owner's Guide for this procedure.
- 2 Turn the VCR on by pressing POWER.
- 3 You are now watching the VCR's picture. To go back to viewing the picture from the TV, press the TV's INPUT button to go back to the previous ANTENNA input position.
- 4 Later, you should turn the RF converter OFF by following instructions on page 49.

If your system includes a home theater receiver or an A/V receiver, refer to your home theater receiver's owner's guide.

### TV without Audio/Video Inputs

If your TV does not have separate audio/video inputs, then your VCR will need to convert the VCR's picture to channel 3 or 4. This is called the video channel. The factory has already selected channel 3; however, if it is a broadcast channel in your area, then you will need to change this to channel 4. To make this change:

#### set up

- 1 To choose channel 4; with VCR power OFF, press CHANNEL  $\wedge$  and REC SPEED on the front panel at the same time. **Ant ch 4** will display on the front panel and the VCR will send signals on channel 4.

If needed, to return to channel 3; with the VCR turned OFF, press CHANNEL  $\vee$  and REC SPEED on the front panel at the same time. **Ant ch 3** will display.

- 2 Turn the VCR on by pressing POWER.

#### operating

- 3 Check to see if the VCR light on the front panel display is lit. If it is not, press VCR/TV on the remote control until the VCR light appears on the front panel. This light must be on when you watch a video tape or use the VCR menus. The VCR light will turn on automatically when you play a tape or use the VCR menus when the RF converter is set to ON. See page 49.
- 4 Turn on the TV and change the TV to the video channel (3 or 4). You are now watching the VCR's picture.

To watch a channel that is different than the channel your VCR is recording, the VCR light must be off. The VCR/TV button turns this light on and off.

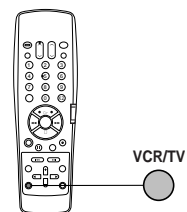
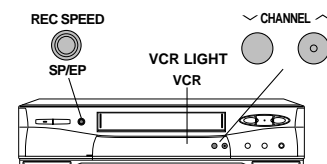
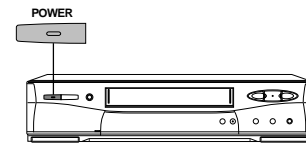

## Playback

### Operating Your Remote Control

#### Installing the Batteries

- 1 To remove the back cover, press the ridged area gently, then push the cover in the direction of the arrow and lift.
- 2 Load the batteries, making sure the polarities (+) and (-) are correct. This is marked inside the battery compartment.

Next, you need to tell the remote control to operate the VCR, not the TV.

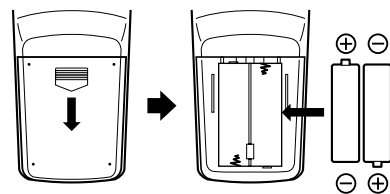

#### Operating the VCR with the Remote Control

The HS-U776 has two VCR remote control operational settings: VCR-A and VCR-B. The HS-U776 is pre-set to VCR-A setting. See page 54 for information about VCR operational setting.

- 1 Set the VCR/TV slide switch on the remote control to VCR position. This "tells" the remote that you want to control the VCR.
- 2 Press VCR/TV and the number button "1" on the remote control at the same time. Now your remote is ready to operate your HS-U776.

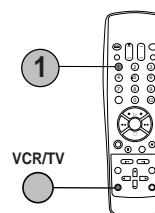

#### Loading a Tape

Tapes can be loaded into your VCR as long as the VCR is plugged in. Even when the VCR POWER is off, loading a tape will automatically turn the VCR on. Use only tapes that have a **SVHS** or **VHS** label.

- 1 Hold the tape so that the long narrow edge with the contents label faces you. The other edge is hinged and should face the VCR. The plastic window that shows the videotape should face up.
- 2 Gently insert the tape evenly into the cassette slot until the VCR automatically takes it in.

If the VCR will not automatically take the tape in, press EJECT and try again.

Your VCR will eject the tape if it is loaded improperly. If the VCR ejects the tape; remove the tape, check to see that the contents label is facing you, that the geared tape reels are facing down, wait a few seconds, and try again.

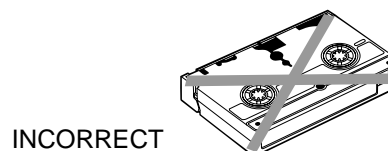
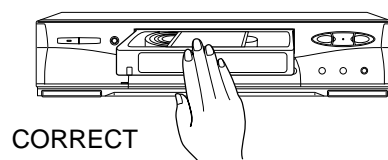

#### Playing a Tape

- 1 Press PLAY on the front panel or the remote control.

The VCR will automatically play the tape at the correct speed. When the VCR reaches the end of the tape, it will automatically rewind to the beginning of the tape and stop.

You can stop playing by pressing STOP.

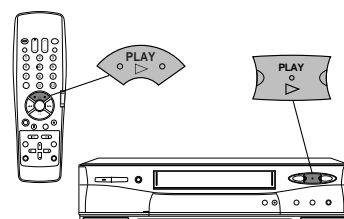

## Playback

### Using Basic Playback Controls

#### Rewinding a tape

While the tape is stopped, press REW on the remote control or on the front panel.

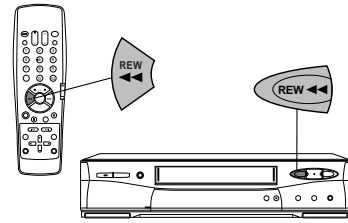

#### Fast forwarding a tape

While the tape is stopped, press FF on the remote control or on the front panel.

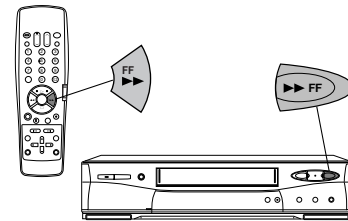

#### Speed Search with picture

While the tape is playing, press FF for forward speed search with picture or press REW for reverse speed search. See page 40 for additional information on searching techniques.

#### Pausing a tape

While the tape is playing, press PAUSE on the remote control or on the front panel to freeze the picture on the screen.

Press PAUSE a second time to return to normal play.

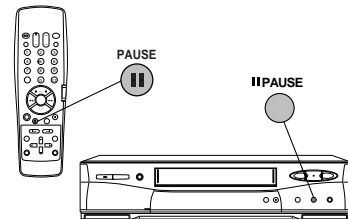

If you leave the VCR in pause for more than 5 minutes, the VCR will automatically stop to prevent damage to the tape.

#### Controlling Vibration During Still Frame

If the picture vibrates during still frame, press the CHANNEL buttons on the front panel until the picture is steady.

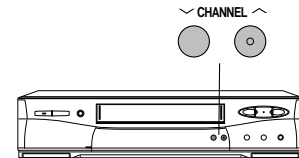

### Unloading a Tape

- 1 Press EJECT on the front panel or on the remote control. If the VCR POWER is off, the VCR will turn on, eject the tape, then turn off.
- 2 Remove the tape.

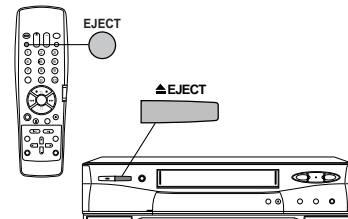

#### Using repaired tapes

*We recommend that you take any broken or torn tapes to a professional for repair. If you repair a torn tape with improper materials, you could damage your VCR when you play the tape.*

#### Head cleaning

Your VCR automatically cleans the head and the drum of the VCR whenever you load a tape. If you see "noise" or snow when playing a tape, eject the tape, re-load the tape, then wait 3 or 4 seconds. Repeat this process several times to improve the picture.

# Setting Up Your VCR

Your VCR comes with Mitsubishi's exclusive **ViewPoint®** on-screen operating system. This system has been developed to simplify the operation of your VCR with clear, understandable language and design.

Before your VCR can receive television channels or you can program your VCR to record, you need to memorize all of the channels you can receive into your VCR and set the clock. Additionally, if you are using a satellite receiver, you need to do a first time setup to memorizing satellite brand code. Fortunately, your VCR makes this an easy process with our menu system.

When using the on-screen menus, use the ADJUST buttons to move the highlight bar up or down and to change the setting of selected features. Press the ENTER button to enter a selection or adjustment. Press the CANCEL button to cancel or clear a setting.

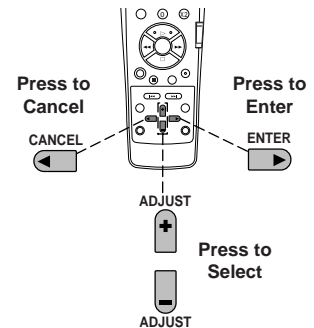

## Memorizing Channels Automatically

Using this process, your VCR will automatically memorize all of the television stations available to you. You can later get rid of unwanted or unused stations.

You need to manually set the brand code for the a satellite receiver.

*If your local cable company scrambles some or all stations, and/or requires you to use a cable box, then your ability to memorize channels would normally be limited. The cable box receives all of your channels, then sends only one to your TV and your VCR, usually on channel 3 or 4.*

*If you are required to use a cable box, you should choose Cable box only or Digital Cable box only option in step 4 on the next page and turn the cable box on. Your HS-U776 will use its Converter Box Control technology to change the channels on the cable box. Make sure you have properly placed the IR Emitter (see page 9).*

*If your cable box or cable system seems incompatible with your new VCR, call your cable company. They may be able to provide solutions to your problems.*

- 1 Set the VCR's input to tuner. To do this, press INPUT on the remote control until a channel number appears on the screen or on the front panel display.
- 2 Press MENU on the remote control. VCR Main Menu comes up. If First Time Set-Up is not highlighted, use the ADJUST buttons on the remote to highlight it.
- 3 Press ENTER. First Time Set-Up menu will appear. Press the ADJUST buttons to select Memorize channels. Press ENTER.

### IMPORTANT

If you are recording or playing back a tape, Not available will flash and an error message will appear. To correct this, stop the tape.

A special note to cable box subscribers

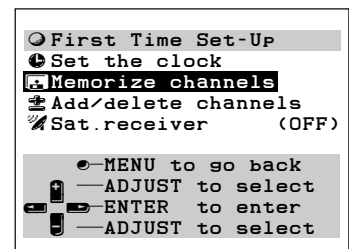
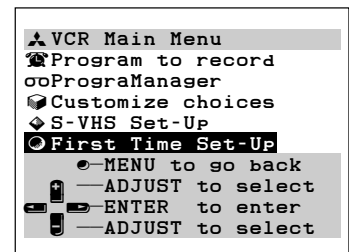

## Setting Up Your VCR

- 4 You will see the menu for sources connected to the VCR. Using the list below as a reference, press the ADJUST buttons to select the kind of antenna you connected.
- **Cable** if you have standard cable service without a cable box, use a cable box with an A/B switch, or your cable box is not remote controllable
  - **Cable box only** if you use a standard cable box
  - **Digital cable box only** if you use a digital cable box
  - **Indoor/outdoor ant.** if you use rabbit ears type or roof mounted type antennas
- After you have selected, press ENTER.

### If you choose Cable or Indoor/outdoor ant.

An on-screen message and the front panel display of your VCR will show you that the VCR is memorizing the stations you can receive. After the VCR has memorized all the channels, the screen will return the VCR's picture.

### If you choose Cable box only or Digital cable box only

You need to tell the VCR which manufacturer makes your cable box or digital cable box, and on which channel the cable box or digital cable box sends a signal.

- 5 Brand code will be highlighted. Press the ADJUST buttons or the number buttons to select the manufacturer's code number for your cable box or digital cable box. The codes are listed on the next page.
- 6 To determine if the Brand code is correct, press CHANNEL on the remote. The channel number on the front panel display should change. Then your cable box or digital cable box should change to the exact same number a moment after it appears on your VCR.

If your cable box or digital cable box does not change channels at all, or does not show the exact same number, try the next Brand code, if another is listed for your type of cable box or digital cable box. Also make sure the IR emitter bulb faces the IR window on the cable box .

If no code number is listed for your cable box, or if none of the listed numbers work, try each code from 1 to 94.

If your cable box or digital cable box cannot be operated by a remote control (if it has a mechanical dial or slide), then your VCR will not be able to change channels on the cable box.

If your cable box will not respond to any of the codes, your VCR cannot change channels on the cable box. You will need to change channels yourself, using the cable box's remote control. You should re-program your VCR, choosing Cable in step 4. When programming to record, you will need to leave your cable box ON and tuned to the channel you wish to record.

- 7 When the Brand code is correct, press ENTER. The screen will add a Channel selection.
- 8 Use the ADJUST buttons to select the channel on which your cable box or digital cable box sends a signal to the VCR (normally channel 3 or 4). If you connected your cable box or digital cable box with audio/video cables, use INPUT to select **L1** (if you used the rear panel jacks), or **L2** (if you used the front panel jacks). You cannot use both digital cable box and satellite receiver. Thus if you selected Digital cable box only in step 4, you cannot select **L2**.

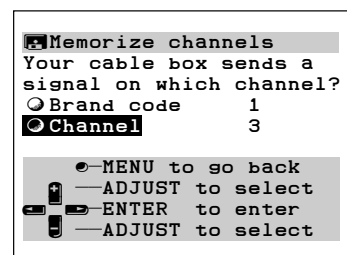
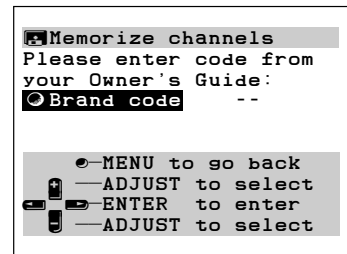
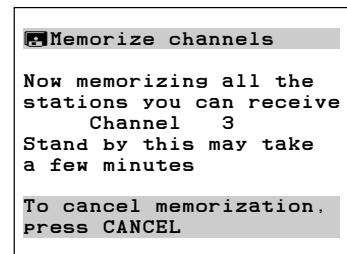
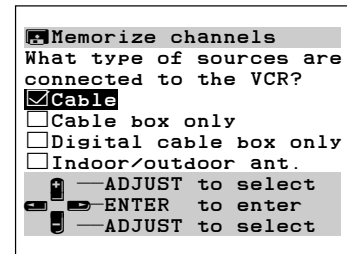



# Setting Up Your VCR

## Cable Box Brand Code

Manufacturer	Code Number	Manufacturer	Code Number	Manufacturer	Code Number
ABC	1, 2, 11	Magnavox	59, 61, 67	Sheritech	57
Archer	29, 58, 65	Movietime	30, 31, 51, 54	SL Marx	5, 14, 29
Century	29, 65	NSC	20, 51, 52	Sprucer	14, 21, 25
Citizen	29, 65	OAK	27, 39, 40, 49, 50, 61	Stargate	5, 14, 29, 65
Diamond	54, 58	Panasonic	14, 21, 25	Sylvania	66
Eagle	17, 18, 19, 61, 62, 63	Paragon	6, 7	Teknika	36
Eastern	68	Pioneer	14, 15, 16, 92, 93, 94	Texscan	53, 66
G C Electronic	29, 65	Philips	26, 61, 62, 63, 64	Tocom	1,2,3,4,5,41,42,43,44,69,91
Gemini	5, 60	RCA	14, 21, 25	Toshiba	32, 33, 34
General Electric	35	Realistic	37, 38	Unika	48
General Instrument	1,2,3,4,5,41,42,43,44,69,91	Regal	45, 48	United Cable	2
Hamlin	22, 23, 45, 46, 47	Regency	68	Universal	30, 31, 54, 65
Hitachi	24	Rembrandt	55, 56	Videoway	6, 7
Jerrold	1,2,3,4,5,41,42,43,44,69,91	Samsung	5, 14, 21, 25, 29	Viewstar	17, 18, 19, 61, 62, 63
Macom	28	Scientific Atlanta	10, 11, 12, 13	Zenith	6, 7, 8, 9

## Digital Cable Box Brand Code

Manufacturer	Code Number
GI	1, 2

- After entering the channel number, press ENTER. The VCR will begin memorizing the available channels. During this process your TV screen, the front panel display, and your cable box or digital cable box should all display each channel number one by one. You can cancel the memorization at any time by pressing CANCEL on the remote control.

After the VCR has memorized all the channels, the screen will return the VCR picture.

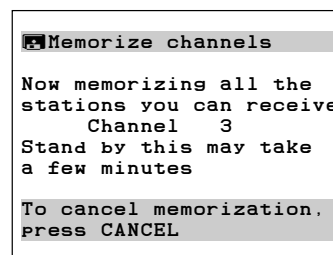

### IMPORTANT

Automatic channel memorizing may include vacant channels if there are stray signals or noise on those channels. If this occurs, you can manually delete the channels using the procedure in the section **Adding and Deleting Channels**.

You do not need to perform this set-up again unless your cable company changes their channel lineup, or you move the VCR to a new address.

## Satellite Receiver Control

If you are using a satellite receiver, you can set up your VCR to change channels on the satellite receiver.

- Make sure you are viewing the picture coming from your VCR. Press MENU on the remote control. VCR Main Menu appears.
- Press the ADJUST buttons on the remote control to select First Time Set-Up. Press ENTER.
- You will see the First Time Set-Up menu. Press the ADJUST buttons to select Sat. receiver.

### IMPORTANT

You cannot select Sat. receiver if you select Digital Cable box only in step 4 of Memorizing Channels Automatically (on page 14).

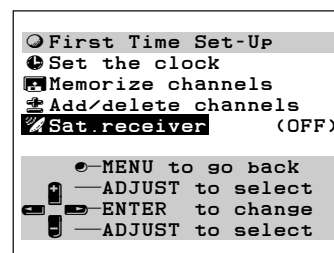

## Setting Up Your VCR

- 4 Press ENTER to select the correct code for your satellite receiver.

<u>Manufacturer</u>	<u>Code</u>
RCA or GE	1
PRIMESTAR®	2
Sony	3
DISH Network	4
Toshiba	5
Panasonic	6
Hughes	7
none	OFF

- 5 After you have selected, press MENU twice to exit the menus.

### IMPORTANT

After you have connected the satellite receiver and set the brand code, you need to see if your VCR can control your receiver. To do this, use CHANNEL or number buttons on the VCR remote to tune to a satellite channel. If the satellite channels appear on your TV, then your VCR can control your receiver.

## Adding and Deleting Channels

If necessary, you can manually add or delete channels after you have completed the automatic channel memorizing. You cannot do this for channels coming from a satellite receiver.

- 1 Make sure that video mute is ON. See page 48.
- 2 Set the VCR's input to tuner. To do this, press INPUT on the remote control until a channel number appears on the screen or the front panel display.
- 3 Press MENU on the remote control. VCR Main Menu appears.
- 4 Press the ADJUST buttons on the remote control to select First Time Set-Up. Press ENTER.
- 5 You will see the First Time Set-Up menu. Press the ADJUST buttons to select Add/delete channels. Press ENTER.

### IMPORTANT

If you are recording, playing back a tape, receiving a video signal from an external input, or watching a satellite receiver channel, then Not available will flash on-screen. To correct this, stop the tape or turn off the menus and switch the VCR's input to tuner.

- 6 You will see the screen for adding or deleting channels. Use the ADJUST buttons to select the channel that you want to add or delete. Press ENTER to add the channel; press CANCEL to delete it.
- 7 When you are finished adding or deleting channels, press MENU three times to exit the menus.

### IMPORTANT

If you use automatic memorizing again, you will lose all of the manual changes you made. All of the channels you deleted will be added; all of the channels you added will be deleted. If your cable box receives only one or two digit channels, you cannot add a three-digit channel.

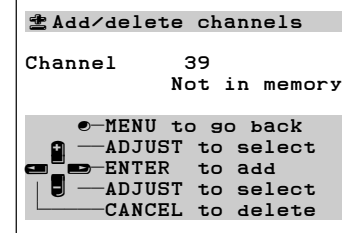
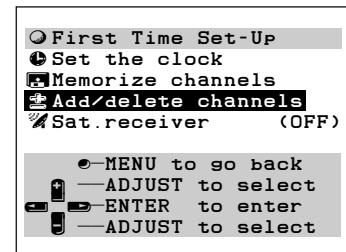

# Setting Up Your VCR

## Selecting a Channel

Now that you have memorized channels, and added or deleted some, you will want to be able to select channels. If you have not yet memorized channels, see page 13, **Memorizing Channels Automatically**. (If you selected digital cable box, you cannot select any satellite channels.)

### Antenna/Cable selections

**indoor/outdoor antenna**  
**cable antenna without box**  
**cable box only**  
**digital cable box**

### Your VCR can receive

VHF/UHF channels 2–69  
cable channels 1–125  
cable box channels 0–99  
digital cable box channels 0–999

### Satellite Receiver selections

Sony, RCA, GE, Toshiba,  
Panasonic, Hughes, DISH Network™

### Your VCR can receive

any channel from 100-999 provided  
by your satellite service  
(cable channels 100-125 cannot be  
selected)

### Satellite Receiver selections

PRIMESTAR®

### Your VCR can receive

any channel from 1-999 provided  
by your satellite service  
(cable channels 100-125 cannot be  
selected)

If you try to select a channel number that the VCR cannot receive, the VCR will not change channels.

### **selecting antenna, cable or digital cable channels sequentially**

Press CHANNEL on the remote control or on the VCR front panel. This will cycle through the channels in sequential numerical order.

When you select the digital cable channels from 100 to 999, holding down the CHANNEL on the remote will advance the channels in 10 channel increments.

### **selecting antenna, cable or digital cable channels directly**

Use the number buttons on the remote control. For example, to choose channel 23, press 2-3. If you select digital cable channels, you can select the three digit channels directly by using the number buttons. For example, to choose digital cable channel 157, press the 1-5-7.

To select a single digit channel, such as channel 5; press 0-5. You can also press 5, then press ENTER.

### **selecting satellite channels sequentially**

Press CHANNEL on the remote or on the VCR front panel. When pressing the up arrow, the lowest satellite channel will follow the highest antenna or cable channel. When pressing the down arrow, the highest satellite channel will follow the lowest antenna or cable channel. The other satellite channels will follow in numerical order. Continuously holding down CHANNEL on the remote will advance the channels in 10 channel increments.

### **selecting satellite channels directly**

For Sony, RCA, GE, Toshiba, Panasonic, Hughes and DISH Network; press the number buttons on the remote. For example, to go to channel 263, press 2-6-3.

For PRIMESTAR channels, press INPUT until the channel number with the PRIMESTAR light (◆) appears on the front panel display. Then press the number buttons on the remote.

For one or two digit channel numbers, press the number buttons, then press ENTER. For example, to go to channel 29, press 2-9-ENTER.

# Setting Up Your VCR

## Setting the Clock

You have to set the clock using either **Setting the Auto Clock** or **Setting the Clock Manually** before you can program your VCR to record.

### Setting the Auto Clock

Your VCR can set the clock automatically by picking up a time signal which some TV and cable channels transmit with their broadcasts. Most PBS stations send this signal; however, this function works only if a channel in your area is broadcasting a time signal. If you don't receive this signal, set the clock manually.

- 1 Press MENU on the remote control. VCR Main Menu will appear.
- 2 Press the ADJUST buttons to select First Time Set-Up. Press ENTER. The First Time Set-Up menu will appear. Use the ADJUST buttons to select Set the clock. Press ENTER.
- 3 You will see the Set the clock menu. Clock set will be highlighted. Press the ADJUST buttons to select AUTO.
- 4 Turn the VCR off to activate the auto clock setting function.

The VCR will search for a channel that carries a time signal, then set your time zone and daylight saving time. If there are only a few channels in your area that carry time signals, it may take about 30 minutes to complete. If you turn the VCR on before the correct time displays, the auto clock setting will be cancelled. See if the clock has been set on the front panel display on the VCR.

If the VCR displays the wrong time, the time zone setting may not be correct. To adjust this, follow the steps in **If the VCR displays the wrong time**. (See the next page.)

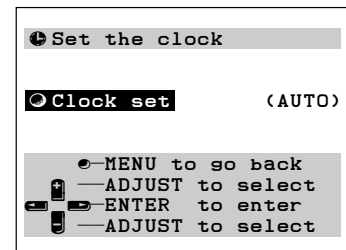
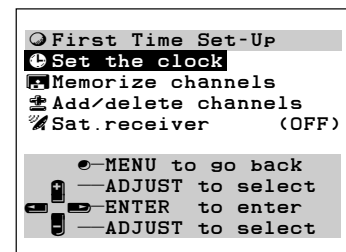

### IMPORTANT

When you memorized channels, if you chose **Cable box only** or **Digital cable box only**, make sure you leave the cable box or digital cable box **on**. At 3:00 am, when the VCR power is off, the VCR will begin to automatically change channels on the cable box, one by one, to set the clock. At this time you cannot use the cable box.

If you want to use the cable box at 3:00 am, turn on the VCR or set the Clock set of the Set the clock menu to **MANUAL**. In both cases, auto clock function will be canceled.

When you memorized channels, if you chose **Cable** or **Indoor/outdoor ant.**, the VCR will set the clock as soon as you turn off the VCR, and at 3:00 am.

After a power failure, the VCR will automatically set the clock again. (If you have set the Clock set setting of the Set the clock menu to **MANUAL**, the auto clock function will not work.)

# Setting Up Your VCR

## If the VCR displays the wrong time

- 1 Follow the procedure on the previous page to step 3. Then press ENTER.
- 2 You will see the Set the clock menu. Channel will be highlighted. If you know the channel that carries a time signal, press the ADJUST buttons to enter the channel. Most PBS stations broadcast a time signal. For fastest response, enter your local PBS station. If you don't know it, leave the channel setting at AUTO. Press ENTER.
- 3 Time zone will be highlighted. Press the ADJUST buttons to select the time zone of your area. Available time zones are: Atlantic, Eastern, Central, Mountain, Pacific, Alaska, and Hawaii. Press ENTER.
- 4 Daylight savings will be highlighted. Press the ADJUST buttons to select AUTO, ON or OFF. If you follow daylight saving time, select ON. If not, select OFF. If you select AUTO, the VCR automatically sets the daylight saving time.
- 5 To activate the auto clock function, turn off the VCR.

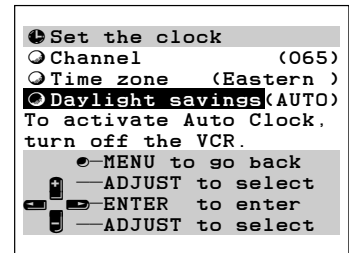
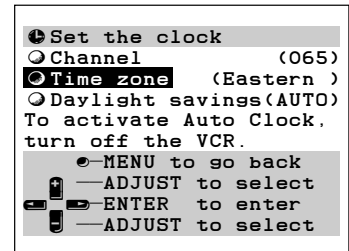
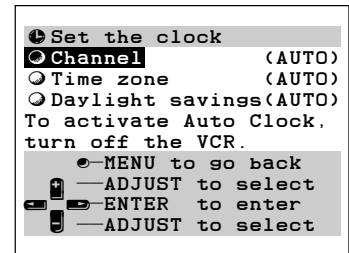

## Setting the Clock Manually

Skip this section if your VCR has set the clock correctly using the auto clock function.

- 1 Press MENU on the remote control. You will see the VCR Main Menu.
- 2 Press the ADJUST buttons to select First Time Set-Up. Press ENTER. First Time Set-Up menu will appear. Press the ADJUST buttons to select Set the clock. Press ENTER.
- 3 You will see the Set the clock menu. Clock set will be highlighted. Press the ADJUST buttons to select MANUAL. Press ENTER.
- 4 Daylight savings will be highlighted. Press the ADJUST buttons to select ON or OFF. If you are currently following daylight savings, select ON. Otherwise, select OFF. Press ENTER.

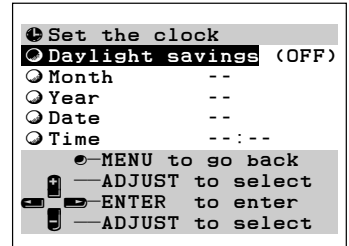
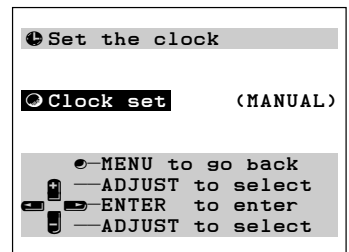

## Setting Up Your VCR

5 Press the ADJUST buttons until the correct month appears on screen. Press ENTER.

6 Press the ADJUST buttons to set the current year. Press ENTER.

7 Press the ADJUST buttons to set the date. Press ENTER.

8 The hour numbers and the am/pm indicator will be blinking. Press the ADJUST buttons to set the hour and am/pm at the same time. Pressing ADJUST + moves the clock *forward*; pressing ADJUST – moves the clock *backward*. Press ENTER.

9 Press the ADJUST buttons to set the minutes. When you have set the correct time, press ENTER. First Time Set-Up menu will appear, and the clock will start running.

10 Press MENU twice to turn off the menus.

You can adjust the daylight saving time manually. When Daylight savings is highlighted, press the ADJUST buttons to select ON or OFF.

If you select ON, the VCR will set the clock forward one hour.

If you select OFF, the VCR will set the clock back one hour.

### IMPORTANT

Any time you adjust this setting, check your programmed recordings to be sure they are set to the correct times.

If you have a Mitsubishi TV with StarSight® feature, the TV can set the time on your VCR. See your TV Owner's Guide for details.

To allow StarSight® to do this, you must set the VCR's Clock set to MANUAL, and the VCR's A/V Network setting to ACTIVE.

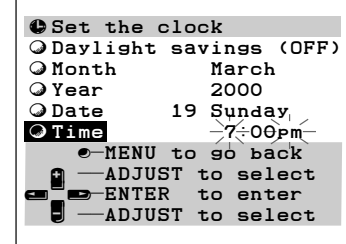
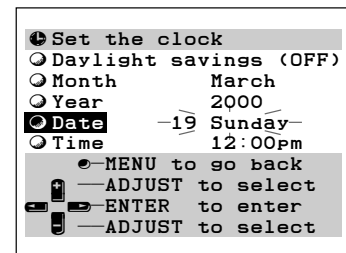
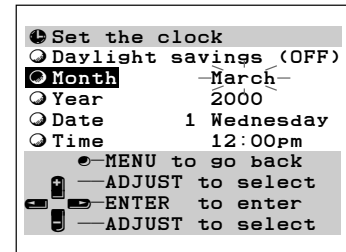

StarSight® is a registered trademark of StarSight Telecast, Inc.

# Recording

Your new VCR offers a wide variety of recording options that take full advantage of our advanced electronics. First, you can learn how to record a current broadcast. Then, in another section of this book called **Timer Recording**, you can learn how to program your VCR to record at a later time and day.

## Recording a Current Broadcast

To record a TV program that is currently playing:

- 1 Load a tape with its erasure prevention tab intact into the VCR.
- 2 Set the recording format. See **Selecting Recording Format** on page 24.
- 3 Set the speed at which you would like to record by pressing SP/EP on the remote control or REC SPEED on the front panel.
- 4 Set the VCR's input to tuner by pressing INPUT until a channel number shown on-screen or on the front panel display. If L1 or L2 appears instead of a channel number, continue to press INPUT until a channel number appears. To record channels from a PRIMESTAR® receiver, press INPUT until a channel number with the PRIMESTAR light (◆) appears on the front panel display.
- 5 Select the channel you wish to record by pressing CHANNEL on the remote control or on the front panel or the number buttons on the remote. If you are using a cable box that the VCR cannot control, select channel 3 or 4 on the VCR, and change the channel on the cable box, not on the VCR.
- 6 Press REC on the remote or REC/② REC LENGTH on the front panel.

Recording will start. When the VCR reaches the end of the tape, it will automatically rewind to the beginning of the tape and stop.

- You can stop recording at any time by pressing STOP or PAUSE on the remote or on the front panel.
- To resume recording from STOP, press REC.
- To resume recording from PAUSE, press PAUSE.  
You cannot use REC/② REC LENGTH on the front panel to resume recording from PAUSE.

### IMPORTANT

If you pause the VCR for more than five minutes, recording will stop automatically to protect the tape.

If you record in extended play (EP), you will only be able to play the tape on a VCR equipped for EP play, such as this one.

If you attempt to record on a tape that has had its erasure prevention tab removed, the VCR will eject it. To record over such a tape, simply place a piece of vinyl tape over the opening.

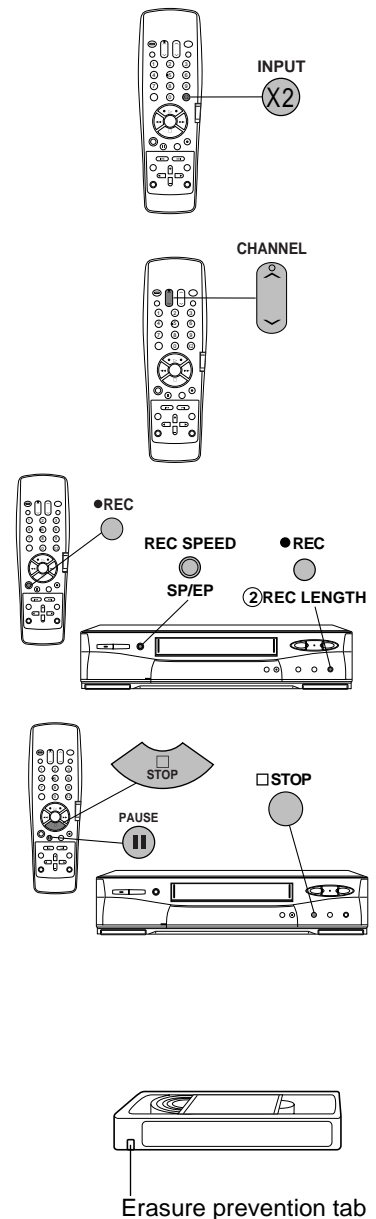

## Recording

### Using One-Touch Recording (OTR)

One-Touch Recording (OTR) is a way to begin recording immediately, and have your VCR stop recording and turn off automatically after your show is over.

- 1 Load a tape with its erasure prevention tab intact into the VCR.
- 2 Set the recording format. See **Selecting Recording Format** on page 24.
- 3 Set the speed at which you would like to record by pressing SP/EP on the remote control or REC SPEED on the front panel.
- 4 Set the VCR's input to tuner by pressing INPUT on the remote until a channel number shows on-screen or on the front panel display. If you would like to record channels from a PRIMESTAR® receiver, press INPUT until a channel number with the PRIMESTAR light (◆) appears on the front panel display.
- 5 Press CHANNEL on the remote control or on the front panel or the number buttons on the remote to select the channel to be recorded. If you are using a cable box that the VCR does not control, select channel 3 or 4 on the VCR, and change the channel on the cable box.
- 6 Press REC/②REC LENGTH on the front panel twice. The first time you press the button, recording will begin. The second press of the same button adds 30 minutes to the OTR timer, displayed on the front panel.
- 7 Press REC/②REC LENGTH for each additional 30 minutes you want to add to the OTR timer, up to 4 hours. If you press the button 10 times, you will see End on the front panel display. The VCR will record until the end of the tape. If you press the button an eleventh time, the VCR will resume normal manual recording.

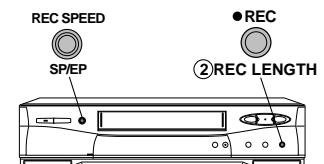
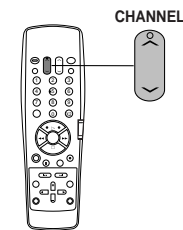
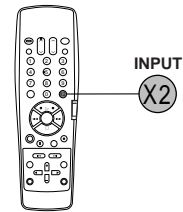

The OTR timer will begin to count down backwards. When it reaches zero, the VCR will stop recording and turn off. The OTR light on the front panel display will light up during the OTR recording.

#### If you program too much time into the OTR timer

Continue pressing REC/②REC LENGTH. After the End point you can start over from zero, adding time in 30 minute intervals.

#### How OTR affects other controls

If you press PAUSE during OTR, the VCR will pause recording, but the OTR timer continues to count down.

Press PAUSE again to resume recording from the record-pause mode. The REC/②REC LENGTH will not resume your recording.

If you press STOP during OTR, you erase the OTR programming.



## Recording

### Using Standby One-Touch Recording (OTR<sup>2</sup>)

Standby One-Touch Recording (also called OTR<sup>2</sup>) is a programming method to begin recording within 24 hours and record in 30 minutes intervals. Before you use OTR<sup>2</sup>, make sure the clock has been set correctly.

- 1 Load a tape with its erasure prevention tab intact into the VCR.
- 2 Set the recording format. See **Selecting Recording Format** on page 24.
- 3 Set the speed at which you would like to record by pressing SP/EP on the remote control or REC SPEED on the front panel.
- 4 Set the VCR's input to tuner. To record PRIMESTAR® channels, see step 4 on previous page.
- 5 Press CHANNEL on the remote control or the front panel to choose the channel to be recorded. If you are using a cable box that the VCR does not control, select channel 3 or 4 on the VCR, and change the channel on the cable box.
- 6 Press PAUSE/①START TIME on the front panel to set the time when you wish recording to start (within 24 hours). The start time is displayed on the front panel. The first time display is the next half-hour increment from the current time. For example, if it is currently 2:15, 2:30 (next half-hour increment) will be displayed. Similarly, if it is currently 2:40, 3:00 (again, the next half-hour increment) will be displayed. Each time you press the button, the start time is delayed by 30 minutes.
- 7 Press REC/②REC LENGTH for each additional 30 minutes you want to add to the OTR<sup>2</sup> timer, up to 4 hours. If you see End on the front panel display, the VCR will record until the end of the tape.

If you have a cable box, a digital cable box, a PRIMESTAR® or a DISH Network™ satellite receiver, leave the cable box or receiver turned ON. If the HS-U776 does not control your cable box, leave the box tuned the station you wish to record.

After 30 seconds, the power will turn off and the programmed recording light will be lit. The VCR will automatically turn on at the OTR<sup>2</sup> start time and recording will begin. When the OTR<sup>2</sup> timer reaches zero, the VCR will stop recording and turn off automatically. If the end of the tape is reached before OTR<sup>2</sup> is finished, the VCR will stop and the power will turn off.

#### IMPORTANT

Other programs you have set to record may be erased if:

- the start times are before the OTR<sup>2</sup> start time
- conflicts with the OTR<sup>2</sup>
- starts within one minute or less after the OTR<sup>2</sup> finishes

If you turn the power on while your VCR is in stand-by for the OTR<sup>2</sup>, the OTR<sup>2</sup> programming will be erased.

#### To cancel OTR<sup>2</sup>

- Turn the power OFF while you are programming the timer.
- Turn the power ON if you have finished programming the timer.

#### How OTR<sup>2</sup> affects other controls

If you press REC/②REC LENGTH on the front panel during OTR<sup>2</sup> recording, 30 minutes will be added to the OTR<sup>2</sup> timer. If you press STOP during OTR<sup>2</sup> recording, you erase the OTR<sup>2</sup> programming.

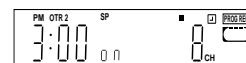
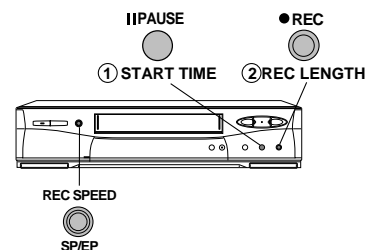
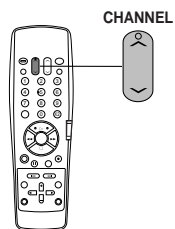
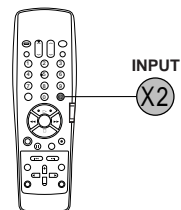

# Recording

## Using S-VHS Set-Up Menu

### Selecting Recording Format

The HS-U776 allows you to choose between recording in standard VHS or Super VHS (S-VHS) when you use an S-VHS tape. If you use a VHS tape, you can choose to record in S-VHS ET (Expansion Technology) mode or VHS. S-VHS ET mode allows you to record in S-VHS format on a VHS tape. Though the picture quality of S-VHS ET mode will not be as clear as that of the S-VHS format, you can record or playback with a higher picture quality than VHS format.

- 1 Press MENU on the remote control. VCR Main Menu appears.
- 2 Press the ADJUST buttons on the remote control to select S-VHS Set-Up. Press ENTER.

#### If you use S-VHS tape for recording:

- 3 Press the ADJUST buttons to select S-VHS record.
- 4 Press ENTER to select the recording format.
  - select **AUTO** if you want to record in **S-VHS**.
  - select **OFF** if you want to record in **VHS**.
- 5 Press MENU twice to exit the menus.

#### If you use VHS tape for recording:

- 3 Press the ADJUST buttons to select S-ET record.
- 4 Press ENTER to select the recording format.
  - select **OFF** if you want to record in **VHS**.
  - select **ON** if you want to record in **S-VHS ET**.
  - **AUTO** will make the VCR automatically select VHS or S-VHS-ET as a result of the PerfectTape® function. See page 49 for the PerfectTape®.
- 5 Press MENU twice to exit the menus.

During playback, the VCR automatically selects the recorded format/mode.

- The S-VHS light on the front panel display will light up during the playback with the tape recorded in S-VHS.
- The S-VHS ET light on the front panel display will light up during the playback with the tape recorded in S-VHS ET.

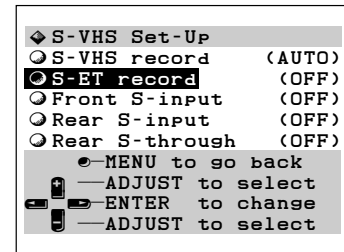
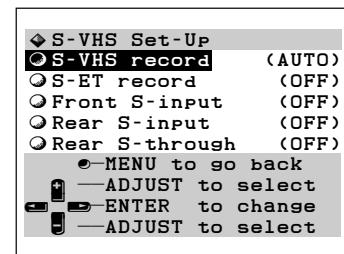
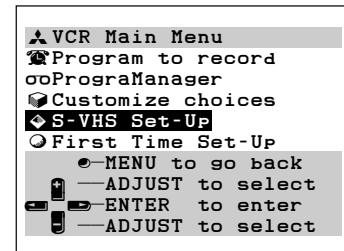

### IMPORTANT

For the best quality recording, use S-VHS tapes and record in the S-VHS format.

The quality of S-VHS ET recordings will vary by the quality of VHS tapes used. For the best quality S-VHS ET recordings, it is recommended that you use HG grade tapes.

S-VHS recordings can be played on:

- S-VHS VCRs.
- VHS VCRs with S-VHS Quasi playback capabilities.

S-VHS ET recording can be played on:

- S-VHS VCRs (not all S-VHS VCRs will be able to play S-VHS ET.)
- VHS VCRs with S-VHS Quasi playback capabilities

Please use this VCR or S-VHS VCR with S-VHS ET mode to playback the tape recorded in S-VHS ET for better picture quality.

# Recording

## Selecting S-input Setting

To watch the picture from other equipment through the VCR, you have to select the S-video input jack or video input jack that matches the equipment. If you connect the satellite receiver to the VCR with an S-video cable, you have to set Rear S-input to ON.

- 1 Press MENU on the remote control. VCR Main Menu appears.
- 2 Press the ADJUST buttons on the remote control to select S-VHS Set-Up. Press ENTER.
- 3 Press the ADJUST buttons to select Front S-input if you use the front panel jacks, or select Rear S-input if you use the rear panel jacks.
- 4 Press ENTER to select which input jack to input.
  - select **OFF** when you want to input signals from **video input jack**.
  - select **ON** when you want to input signals from **S-video input jack**.
- 5 Press MENU twice to exit the menus.

## Using S-through

This function allows you to view the video signal from the equipment connected to the back of the VCR even when the VCR is off. To use this function, you have to connect your VCR and TV, and also connect your VCR and the other equipment with an S-Video cable. For example, if you connect satellite receiver with an S-Video cable, you can watch the satellite video signal on your TV with the VCR power off when you set Rear S-through to ON.

- 1 Press MENU on the remote control. VCR Main Menu appears.
- 2 Press the ADJUST buttons on the remote control to select S-VHS Set-Up. Press ENTER.
- 3 Press the ADJUST buttons to select Rear S-through.
- 4 Press ENTER to set Rear S-through to ON or OFF.
- 5 Press MENU twice to exit the menus.

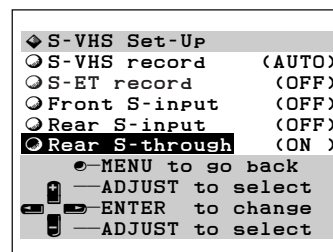
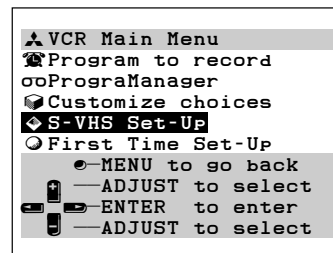
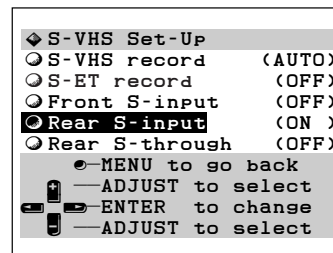
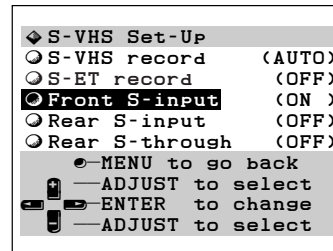
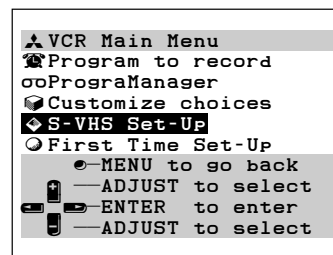

# Recording

## Using Audio and Video Functions

The audio and video function menus allow you to set things such as listening to the stereo track of your recording, or setting the tape length to have the remaining time display function work properly. The VCR will display the functions and settings on your TV screen. The first section describes the functions, the next section tells you how to adjust the functions.

<u>Audio functions</u>	<u>Video functions</u>	
audio monitor	tape (length)	repeat playback
normal record	PerfectTape Select	PerfectTape®
	counter zero stop	

### Descriptions of Audio Functions

#### Audio monitor (Listen to):

This allows you to listen to the various audio tracks that your VCR is capable of recording.

- Choose **Stereo** to listen to both stereo channels.
- Choose **L** to listen to the left channel of a stereo track.
- Choose **R** to listen to the right channel of a stereo track.
- **Mono** track is lower in quality than the others. The audio monitor is automatically set to **Mono** if you are watching a tape that was not recorded in VHS Hi-Fi. Set the audio monitor to **Mono** to hear SAP signal recorded on the mono track of a Hi-Fi tape.

#### IMPORTANT

**Surround Sound systems:** If you have your VCR connected to a surround sound system, set the audio monitor to **Stereo**. Surround sound requires both left and right channels to create the rear channel effects.

While the VCR is not playing a tape, you will see the following displays on the TV screen for 3 seconds when you change the channel or press DISPLAY.

If you change the channel to:	Display
stereo broadcast	Stereo
SAP broadcast	SAP
stereo and SAP	Stereo + SAP

While the VCR is playing a tape, you will see the following displays on the TV screen for 4 seconds when you press DISPLAY.

The audio monitor you listen to	Display
Stereo	Audio Stereo
L	Audio L
R	Audio R
Mono	Audio Mono

#### Normal recording (Record):

When your VCR is recording, it actually records the audio portion of a program twice: once on the stereo Hi-Fi tracks, and once on the mono track. Additionally, your VCR can receive Separate Audio Program (SAP) broadcasts. A SAP broadcast is an alternative soundtrack for a program; it is often a sound track in another language. The SAP broadcast is recorded only on the mono track.

Use the normal recording function to record the SAP broadcast on the mono track by choosing **STEREO+SAP**. Otherwise, choose **Stereo**. In either case, the main program is recorded on the stereo Hi-Fi track. Also, if there is no SAP broadcast, the VCR will record the main program on the mono track.

# Recording

## Descriptions of Video Functions

### Tape

Adjust this function to ensure the accuracy of the Remaining Time display. The remaining time function does not work properly with a tape that is less than 30 minutes long.

<u>Length of tape</u>	<u>Use Setting</u>
2 hours long or less (T-30 through T-120)	T-120
160 minutes (T-160)	T-160
180 minutes (T-180)	T-180
210 minutes (T-210)	T-210

### PerfectTape Select (Play PerfectTape)

This function turns on the PerfectTape Select circuitry, which automatically maximizes picture quality when playing a worn or poor quality tape. Set the switch to **Soft** to soften the picture, set it to **Sharp** to sharpen it. Set it to **Normal** when you do not want to use this feature. Use **Normal** on new or high quality tapes. If it is set to **Auto**, the VCR will automatically select the ideal setting of PerfectTape Select depending on the condition of the tape.

### Counter zero stop (Counter zero stop)

This function is used to automatically fast forward or rewind to "0H00M00S" and stop the tape. See page 41 for more information on this feature.

### Repeat playback (Repeat play)

Use this function to repeatedly play a section of tape between two index marks. See page 42 for more information on this feature.

### PerfectTape®

PerfectTape function allows you to test the quality of video tapes you will record on. After each test, the VCR adjusts its circuitry in order to make the best possible recording on your tape. See page 49 for more information on this feature.

## Selecting and adjusting the audio and video functions

- 1 Press AUDIO/VIDEO on the remote control to see the function menu.
- 2 Press AUDIO/VIDEO repeatedly until the function you want to adjust appears.
- 3 Press the ADJUST buttons on the remote to adjust the setting.

The functions will disappear if you do not press any buttons for 5 seconds.

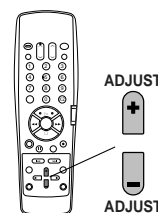
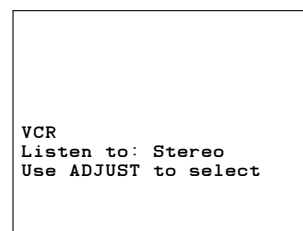
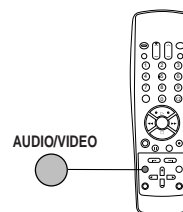

**IMPORTANT**

The audio and video function menus do not appear:

- when the VCR menu is displayed
- during special effects playback

**Tape** function does not appear during playback.

**Play PerfectTape** is displayed only during playback.

**PerfectTape®** displays only when a tape, with its erasure tab intact, is loaded and the VCR is stopped.

# Timer Recording

Mitsubishi offers 3 ways to set your VCR to record upcoming broadcasts. Choose from:

## Conventional VCR timer recording

**Quick Program (easy)** --VCR does not need to be on to begin programming  
**VCR Plus+® system programming (easy)**

You can schedule up to 8 recording events within a one month period. Clock must be set before **any** timer recordings can be performed.

## Conventional VCR Timer Recording

- 1 Load a tape with its erasure prevention tab intact into the VCR.
- 2 Press MENU. VCR Main Menu appears on your screen. Use the ADJUST buttons to select Program to record. Press ENTER.

If there is at least one programmed recording already entered, you will see the Recap screen. Wait 4 seconds, and the VCR Plus+ Program to record menu will appear.

### IMPORTANT

If you have already programmed 8 recording events, Program memory is full will appear on your screen for 3 seconds, and then the Recap screen will appear. Use CANCEL to erase an entry before you can add another one.

- 3 VCR Plus+ Program to record menu appears. See page 31 to learn how to program with VCR Plus+®. To pass this screen, press ENTER.

- 4 Program to record menu appears. Press the ADJUST buttons to choose the channel you would like to record; for example, channel 2. Press ENTER.
  - If you are using a **cable box** that the VCR cannot control, enter the channel number on which the cable box sends a signal to your VCR (usually channel 3 or 4).
  - If you are recording from a **DSS®**, **PRIMESTAR®** or **DISH Network™ satellite receiver**, simply choose the channel you would like to record; for example, channel 245. **SAT** will display next to the channel number.
  - To record from an **external source**, press INPUT or press the ADJUST buttons to:
    - Select External L1 for a source connected to the rear panel.
    - Select External L2 for a source connected to the front panel.

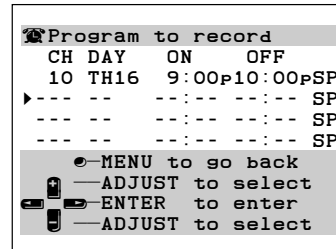
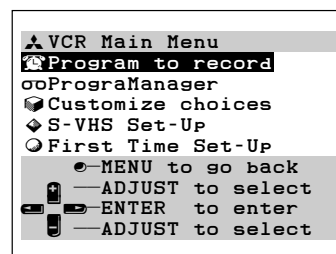

Recap screen

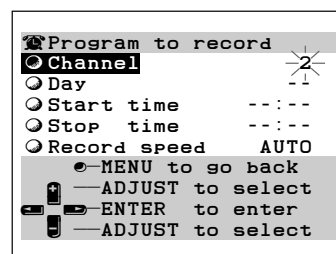
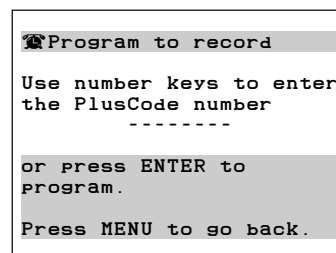

## Timer Recording

- 5 Day will flash. Press the ADJUST buttons to choose the day on which you want to record; for example, Monday the 13th.

Your choices are:

- a single day up to one month away
- every day from Monday through Friday; for example, to tape a soap opera. To program, press the ADJUST buttons until Monday-Friday appears.
- the same day every week; for example, to tape your favorite weekly sitcom. To program, press the ADJUST buttons until Every and the desired day of the week appears.

Press ENTER once you have made your choice.

- 6 The hour numbers of the start time will flash. Press the ADJUST buttons to set the hour when recording is to start. Press ENTER.
- 7 The minute numbers of the start time will flash. Press the ADJUST buttons to set the minutes when recording is to start. Press ENTER.
- 8 Set the stop time the same way as the start time, using steps 6 and 7.

- 9 Press the ADJUST buttons to set the recording speed: SP = standard play; EP = extended play; AUTO = auto. **Auto speed programming** is discussed on page 33. Press ENTER.

### IMPORTANT

If you press ENTER when you set the timer recording incompletely, Program is not completed will appear on your screen.

If two programmed recording times overlap, VCR is already programmed for that time will display on your screen for about 3 seconds, and then the Recap screen will appear. The program you have just set will flash for 3 seconds and the start time and the stop time will be shown in red letters. The start and stop time of the overlapped program will be highlighted in red color. You will need to erase one of them.

- 10 The programmed memory will appear on the Recap screen. "S" next to the channel number indicates satellite channels.
- 11 To program additional recording times, select an empty program line by pressing ADJUST buttons. Press ENTER. The VCR Plus+ Program to record menu will appear. Continue the programming procedure from step 3.
- 12 When you are finished with all programming, check the following:
- If you have a cable box, a digital cable box, a PRIMESTAR® or a DISH Network™ satellite receiver, leave the cable box or receiver turned ON.
  - If your VCR does not control your cable box, leave the box tuned to the station you wish to record.
  - Turn the VCR power OFF and make sure the programmed recording light is lit.

### IMPORTANT

When programmed recording of 4 and under are entered, only 4 of the 8 program lines appear on the Recap screen at any one time. To see additional program lines, press the ADJUST buttons to scroll the lines on the screen.

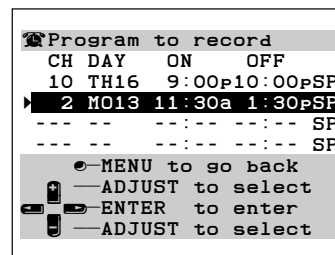
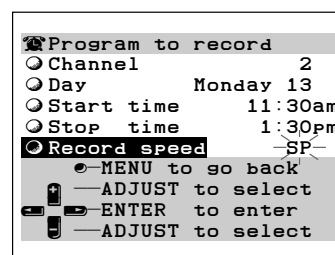
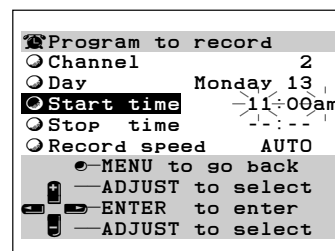
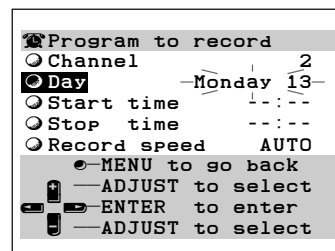

Recap screen

# Timer Recording

## Canceling a recording in progress

There are two ways to cancel a recording in progress:

Press STOP. The recording stops, but the program is not cancelled. Therefore, if you press REC, the recording will start again.

Press POWER on the front panel. The recording stops and the program is cancelled.

## Programming not cancelled

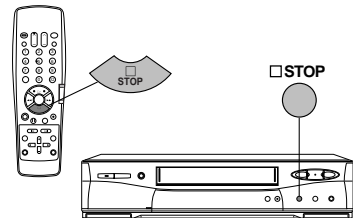

## Changing while programming

To change one of your settings (such as start time) while you are programming:

Press ENTER to move forward through the program list.

Press CANCEL to move backward.

Then use the ADJUST buttons to change the setting.

## Programming cancelled

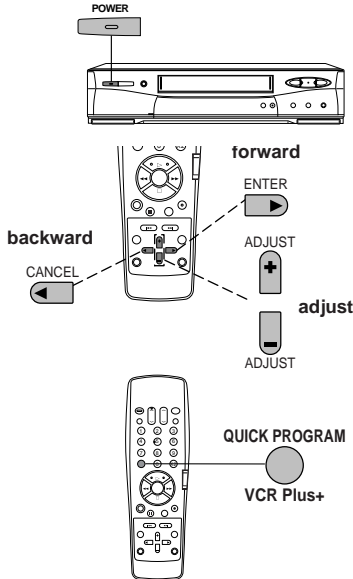

You will cancel the entire program if you press CANCEL while the channel number is flashing.

## Quick Program

Quick Program is an exclusive Mitsubishi feature that simplifies the process of programming your VCR to record. When you press QUICK PROGRAM/VCR Plus+ on the remote control, you will immediately see the VCR Plus+ Program to record menu and can begin programming right away.

You can use this feature even when the VCR is stopped, playing, recording, fast forwarding, rewinding, or off. (Quick program does not work while using OTR<sup>2</sup>.)

Quick Program is also an Active A/V Network feature. If you have a Mitsubishi TV with Active A/V Network, see page 45 for more information.

- 1 Press QUICK PROGRAM/VCR Plus+ on the remote control. If the VCR is off, it will turn on. After tuning your TV to the correct channel or input, VCR Plus+ Program to record menu will appear.

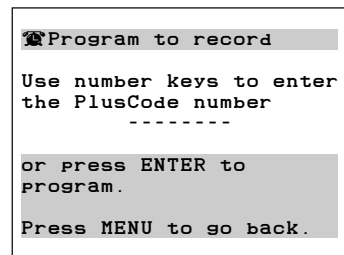

**IMPORTANT**

If the VCR memory is full, Program memory is full will appear for 3 seconds, and then the Recap screen will appear. Use CANCEL to erase an entry before you can add another one.

- 2 Complete steps 3 through 10 in **Conventional VCR timer recording**. (See page 27.)

When you have finished, press QUICK PROGRAM/VCR Plus + again.

If the VCR is stopped, it will turn off and be ready to record your program at a later time.

If the VCR is playing, recording, fast forwarding or rewinding, the menus will turn off, but the VCR power will remain on.

## Recap screen

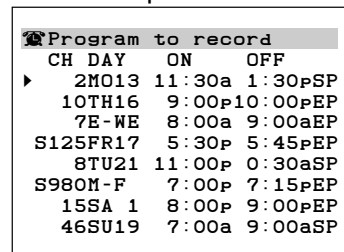

- 3 When you are finished with all programming, check the following:
  - If you have a cable box, a digital cable box, a PRIMESTAR<sup>®</sup> or a DISH Network<sup>™</sup> satellite receiver, leave the cable box or receiver turned ON.
  - If your VCR does not control your cable box, leave the box tuned to the station you wish to record.
  - Make sure the VCR is turned OFF and the programmed recording light is lit before the recording time.



## Timer Recording

### IMPORTANT

If you press QUICK PROGRAM/VCR Plus+, but the clock is not set, Set the clock menu will appear. Set the clock manually.

If you have set the A/V Network to ACTIVE, point your remote control at the TV when using Quick Program.

## VCR Plus+® System Programming

The VCR Plus+® system allows you to program your VCR to record by simply entering a PlusCode programming number. You can find this number in *TV Guide* or possibly your local TV listings.

- 1 Load a tape with its erasure prevention tab intact into the VCR.
- 2 Press MENU. VCR Main Menu appears on your screen. Use the ADJUST buttons to select Program to record. Press ENTER.

### IMPORTANT

If the VCR memory is full, Program memory is full will appear for 3 seconds, and then the Recap screen will appear. Use CANCEL to erase an entry before you can add another one.

If there is at least one programmed recording already entered, the Recap screen will appear. Wait 4 seconds, and the VCR Plus+ Program to record menu will appear.

- 3 VCR Plus+ Program to record menu will appear. Use the number buttons on the remote control to enter the PlusCode number for the television show you want to record. For example, if the PlusCode number for the program you want to record is 5678, simply enter 5-6-7-8. See your local newspaper or *TV Guide* for PlusCode numbers.
- 4 If you enter a number incorrectly, press CANCEL. When you have finished entering the PlusCode number, press ENTER.

### IMPORTANT

If the code number you entered is wrong, PlusCode Not a valid number will display on the screen for 3 seconds, and then the VCR Plus+ Program to record menu will reappear.

- 5 Use the ADJUST buttons to select whether you want to record your program once, daily, or weekly.
  - **Once** will record a program one time.
  - **Daily** will record the same channel at the same time, Monday through Friday.
  - **Weekly** will record the same channel at the same time, on the same day each week.

After you have made your choice, press ENTER.

### IMPORTANT

If two programmed recording times overlap, VCR is already programmed for that time will display on the screen. You will need to erase the previous program before you can enter the new one.

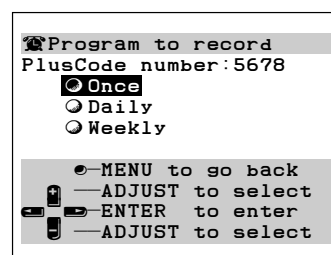
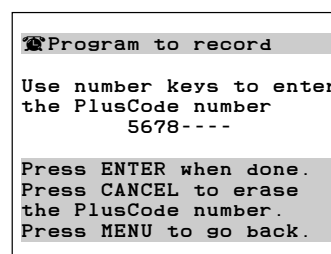
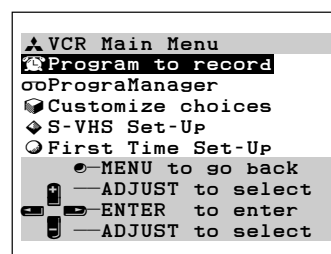

## Timer Recording

- 6 Recap screen will appear. The program you have chosen to record will be highlighted.

The channel number will appear in blue color. Make sure that the correct channel number is shown on the screen. If the displayed number is not correct, press INPUT to make the number flash, then press the ADJUST buttons to correct the channel number. Press the ENTER to complete. "S" will appear next to the channel number when you select a satellite channel.

- 7 If you wish to change the record speed, press ENTER repeatedly until the record speed is flashing. Change the recording speed by pressing the ADJUST buttons. Press ENTER.
- 8 To program additional recording times, select an empty program line by pressing the ADJUST buttons. Press ENTER. You will return to the VCR Plus+ Program to record menu. Continue the VCR Plus+® programming procedure from step 3.
- 9 When you are finished with all programming, check the following:
- If you have a cable box, a digital cable box, a PRIMESTAR® or a DISH Network™ satellite receiver, leave the cable box or receiver turned ON.
  - If your VCR does not control your cable box, leave the box tuned to the station you wish to record.
  - Turn the VCR power OFF and make sure the programmed recording light is lit.

If you want to stop the programmed recording after it starts, press POWER on the front panel.

Recap screen

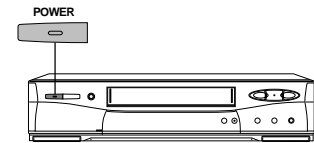
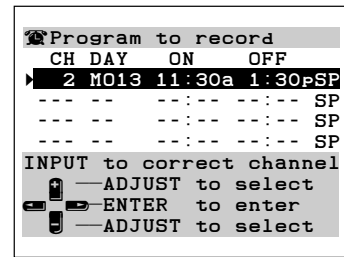

## Timer Recording

### Timer Recording Hints

To use the VCR before timer recording begins, press POWER on the remote once. This turns the programmed recording light off and the VCR on. If you use POWER on the front panel for this purpose, press it twice. Pressing it once turns off the programmed recording light; pressing it again turns the VCR on.

When you are finished using the VCR, turn the VCR power off again. Make sure the programmed recording light is back on.

After a program has been recorded, the VCR memory of that program is cleared (unless you have scheduled the VCR to record the program every day or every week).

If there is already a program in the VCR's memory, you will see the Recap screen when you bring up the menus for programming to record (unless you are programming with the QUICK PROGRAM/VCR Plus+). If the VCR's memory is full, Program memory is full will appear on the screen. If so, you must erase a program before you can enter a new one.

If a tape runs out during timer recording, the VCR ejects the tape and the programmed recording light and the tape status symbol will flash. Load a new tape and press REC. Recording will resume.

If you forget to load a tape, the programmed recording light and the tape status symbol will flash when you turn the VCR power off. (A tape without an erasure tab will be ejected. To correct this, load a tape with its erasure tab intact, and turn off the VCR.)

Do not overlap the recording times you enter into the VCR. If you set two programmed recording times overlap, VCR is already programmed for that time will appear on your screen.

Remember that the VCR will record over the next section of tape. If you want to save a tape, remove it and instead use a different tape for a new recording.

Your VCR will not record over a tape that has the erasure prevention tab removed. All rental movies have this tab removed, so they are safe from being accidentally erased.

### Auto speed programming

Use auto speed programming if you want to record as much of the program as possible in standard play (SP) speed, but you want the VCR to automatically switch to extended play (EP) if there is not enough tape left.

Auto speed programming is only available for one program. In the first slot, the recording speed default is AUTO.

Make sure that the Tape video function matches the length of tape you are using. See **Selecting and adjusting the audio and video functions** on page 27.

At the point where the recording mode changes from standard play (SP) to extended play (EP), some noise may be in the picture or sound when playing the tape.

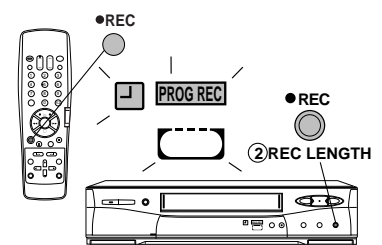
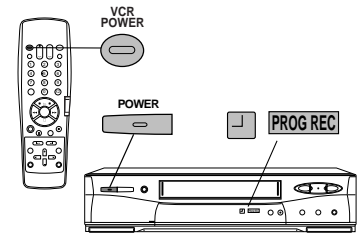

# Timer Recording

## Program caution

If your VCR is set to record, but the power is still ON within 3 minutes before timer recording starts, this screen will appear to remind you to turn off the VCR.

If the VCR is still turned on 12 seconds before the start time of the recording, that timer recording will be cancelled.

## TV programs that end on the day after

If you want to start the recording at 11:00 PM and end it at 2:00 AM the next day, simply set the start time to 11:00 PM on the recording start day and the end time to 2:00 AM. There is no need to change the day of the week.

## Program skip using menus

Sometimes you may want to skip one day of a timer recording but do not want to erase it. Program skip will prevent the recording, for that day only, of a program you have scheduled to record every day or every week.

- 1 Press MENU on the remote control. Your VCR will turn on and VCR Main Menu will appear. Press the ADJUST buttons to select Program to record. Press ENTER.
- 2 Recap screen will display for 4 seconds. While this screen is displayed, press the ADJUST buttons to place the cursor arrow next to the program you wish to skip.
- 3 Press STOP. The cursor arrow will change to a **X**.
- 4 Press MENU twice to turn off the menus.

To resume recording every day or every week, change the **X** to the cursor arrow by following steps 1 to 4 again.

## Program skip using the POWER button

If you have entered only one program into your VCR's memory, you can skip the program without going into the VCR's menus. Simply press POWER on the front panel once. The programmed recording light will turn off, and the program will be skipped. If you decide not to skip the program, press POWER on the front panel twice; the programmed recording light will light up again.

## Changing timer recording settings

- 1 Press MENU on the remote control. Your VCR will turn on and VCR Main Menu will appear. Press the ADJUST buttons to select Program to record. Press ENTER.
- 2 Recap screen will display for 4 seconds. While this screen is displayed, press the ADJUST buttons to place the cursor arrow next to the program you wish to change. Press ENTER. You will see the Program to record setting menu.
- 3 Press ENTER repeatedly to select the item you wish to change. Use the ADJUST buttons to change it. Then press ENTER repeatedly to return the altered program to the Recap screen.
- 4 Press MENU twice to turn off the menus. Then press POWER to turn off the VCR. Make sure the programmed recording light is on.

## program caution

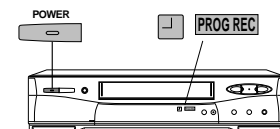
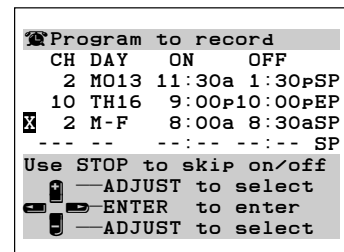
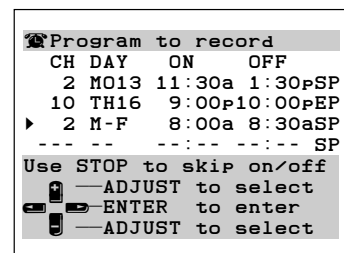
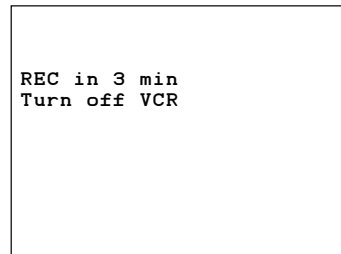

## Recap screen

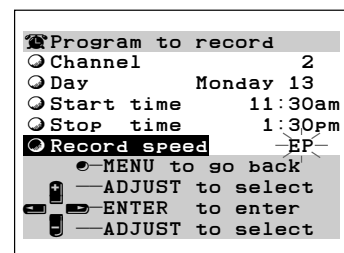
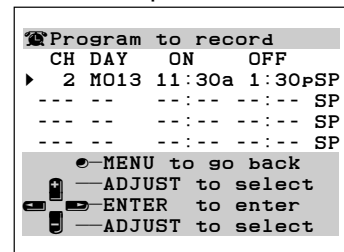

## Timer Recording

### Canceling a timer recording before the recording starts

- 1 Press MENU on the remote control. Your VCR will turn on and VCR Main Menu will appear on your screen. Use the ADJUST buttons on the remote control to select Program to record. Press ENTER.
- 2 Recap screen will display for 4 seconds. While this screen is displayed, press the ADJUST buttons to place the cursor next to the program you wish to cancel.
- 3 Press CANCEL. The program is erased.
- 4 Press MENU twice to turn off the menus.

Recap screen

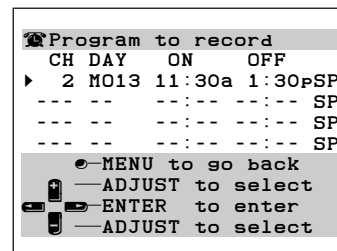

### Using a satellite receiver

If you are using a Panasonic, RCA, Sony, Toshiba, or Hughes satellite receiver, your VCR will turn the receiver on when a timer recording begins and off when the recording ends.

However, if you are using a PRIMESTAR® or DISH Network™ receiver, you will have to turn the receiver on before a timer recording begins.

Before turning off the VCR, to put your VCR in stand-by for recording, make sure that your satellite receiver's menu turns off.

You can watch satellite channels through your VCR even when the VCR is turned off but only if you connected your VCR and TV with an S-Video cable and the Rear S-through in the S-VHS Set-Up menu is set to ON. If you used a standard video cable, you can only view satellite channels through your VCR when the VCR is on.

### TIMER RESET

You can use TIMER RESET on the rear panel to erase both the clock and all timer recordings.

To use TIMER RESET, press it with a pencil or a ball point pen. The power will turn off and the clock will be cleared. All timer recordings are erased.

If you have set the Clock set setting of the Set the clock menu to AUTO, the auto clock function will automatically set the clock again.

### Memory backup

If the VCR is without power for 30 minutes or less, it will retain the clock and the programmed settings. The VCR must have been plugged in for at least an hour beforehand to charge this backup. If the power is lost for more than 30 minutes, the time and the programmed settings will be lost.

If you have set the Clock set setting of the Set the clock menu to AUTO, the auto clock function will automatically set the clock again when power is restored.

VCR Rear Panel

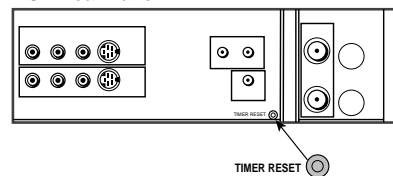

# Editing Features

## Using Two VCRs to Copy

There are two basic ways to make a copy of a tape.

One way is to use the HS-U776 to record and another VCR for playback.

The other way is to use another VCR to record and use the HS-U776 for playback.

Regardless of which method you may choose, you will need one RCA audio cable and one S-video cable to connect the two VCRs. If you do not have these cables, they are available at your local electronics dealer. You can use either a standard RCA video cable or an S-video cable. The highest quality is achieved through an S-video cable.

### Using the HS-U776 to record from another VCR

- 1 Connect the audio cable to AUDIO OUT L and R on the playback VCR and to AUDIO IN L and R on the HS-U776. If the playback VCR is mono, use only the AUDIO IN L on the HS-U776.
- 2 If the playback VCR is standard VHS, connect a video cable to VIDEO OUT on the playback VCR and to the VIDEO IN on the HS-U776. If the playback VCR is S-VHS, connect an S-video cable to S-VIDEO OUT on the playback VCR and to the S-VIDEO IN on the HS-U776.
- 3 If the playback VCR is Hi-Fi, set the audio monitor to **Stereo**.
- 4 Use INPUT to set the HS-U776 to **External 1** (L1) if you used the HS-U776 **rear** panel jacks, or **External 2** (L2) if you used the HS-U776 **front** panel jacks.
- 5 Put a blank tape into the HS-U776. If you are recording in S-VHS, be sure to use an S-VHS tape. Make sure that the S-VHS record or S-ET record in the S-VHS Set-Up menu is set correctly. See page 24, **Selecting Recording Format**. Make sure that the Front S-input or Rear S-input in the S-VHS Set-Up menu is set correctly. See page 25, **Selecting S-input Setting**.
- 6 Put the tape you want to copy into the playback VCR and find the cue point. Press STOP if the picture starts playing.
- 7 On the HS-U776, press REC, then PAUSE.
- 8 On the playback VCR, press PLAY, then PAUSE.
- 9 Press the PAUSE buttons on both VCRs at the same time to begin copying the tape.
- 10 When finished, press STOP on both VCRs.

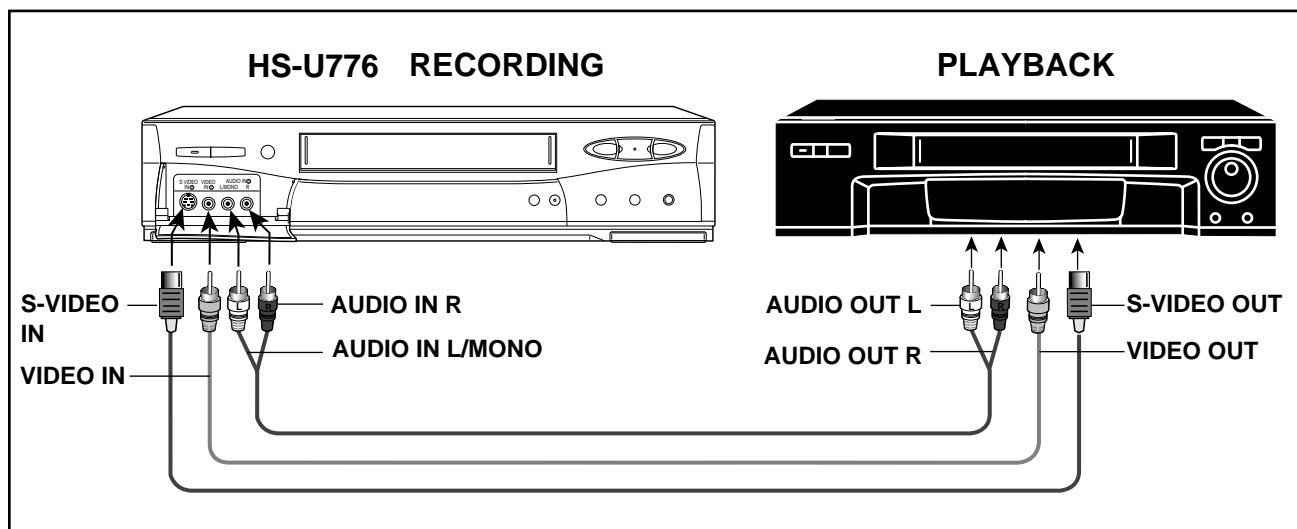

## Editing Features

### Using the HS-U776 to playback to another VCR

- 1 Connect one stereo audio cable to AUDIO IN L and R on the recording VCR, and to AUDIO OUT L and R on the HS-U776. If the other VCR is mono, you need a Y-adaptor to record both audio channels.
- 2 If the recording VCR is standard VHS, connect a yellow video cable to VIDEO IN on the recording VCR and to VIDEO OUT on the HS-U776. If the recording VCR is S-VHS, connect an S-video cable to S-Video IN on the recording VCR and to S-VIDEO OUT on the HS-U776.
- 3 Set the audio monitor on the HS-U776 to **Stereo**. You should set the sharpness in the audio and video function to **standard** to improve the quality of your copy. See **Selecting and adjusting the audio and video functions** on page 27.
- 4 Set the input of the recording VCR to **External**.
- 5 Put a blank tape into the recording VCR. If the recording VCR is an S-VHS VCR, be sure to use an S-VHS tape.
- 6 Put the tape you want to copy into the HS-U776 and find the cue point.
- 7 On the recording VCR, press REC, then PAUSE.
- 8 On the HS-U776, press PLAY, then PAUSE.
- 9 Press the PAUSE buttons on both VCRs at the same time to begin copying the tape.
- 10 Press STOP on both VCRs when you are finished.

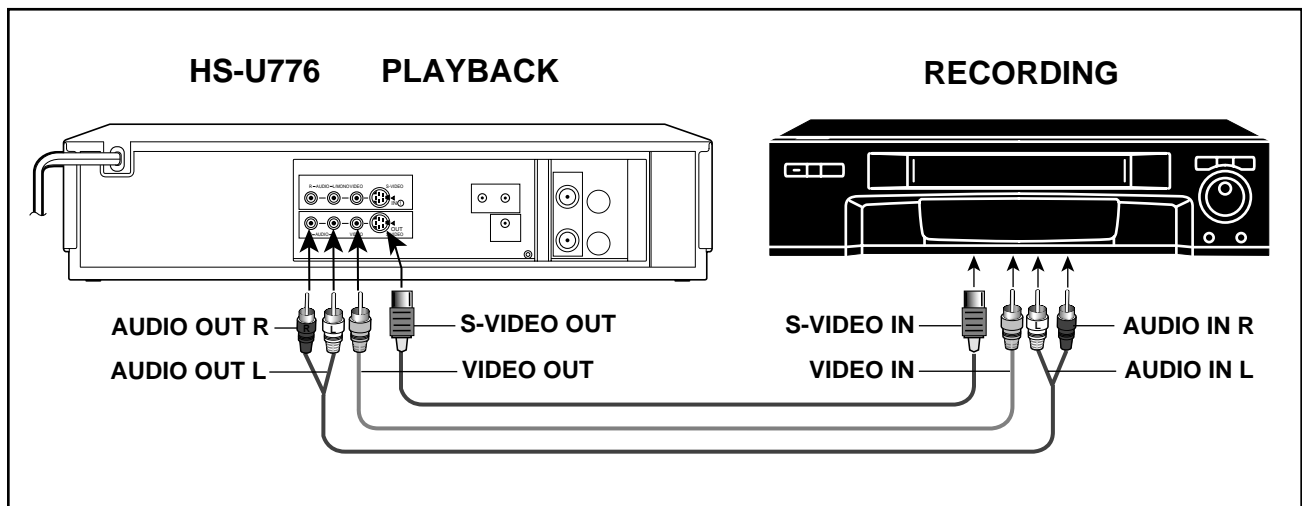

# Advanced Features

## Advanced Playback Controls

### Special effects

You can use FF and REW on the front panel, or the **◀◀** and **▶▶** on the remote to control the playback speed of the tape.

#### Using the FF and REW on the front panel to control the playback speed

- 1 While the VCR is playing a tape, press PAUSE to freeze the picture.
- 2 Press the FF or REW on the front panel. Each press of FF changes the playback speed by one step in the forward direction. Each press of REW changes the speed by one step in the reverse direction. (See the chart below.)
- 3 To resume normal playback, press PLAY.

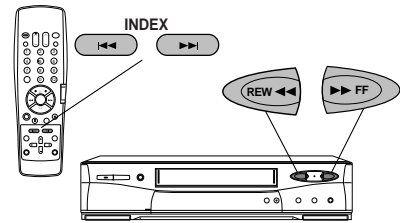

#### Using the **◀◀** and **▶▶** on the remote to control the playback speed

- 1 While the VCR is playing a tape, press **◀◀** or **▶▶** on the remote control. Each press of **▶▶** changes the playback speed by one step in the forward direction. Each press of **◀◀** changes the speed by one step in the reverse direction. (See the chart below.)
- 2 To resume normal playback, press PLAY.

After about 5 minutes in the still or slow-motion mode, the VCR will automatically stop to avoid damage to the tape. The picture may vibrate vertically when you pause the VCR's picture.

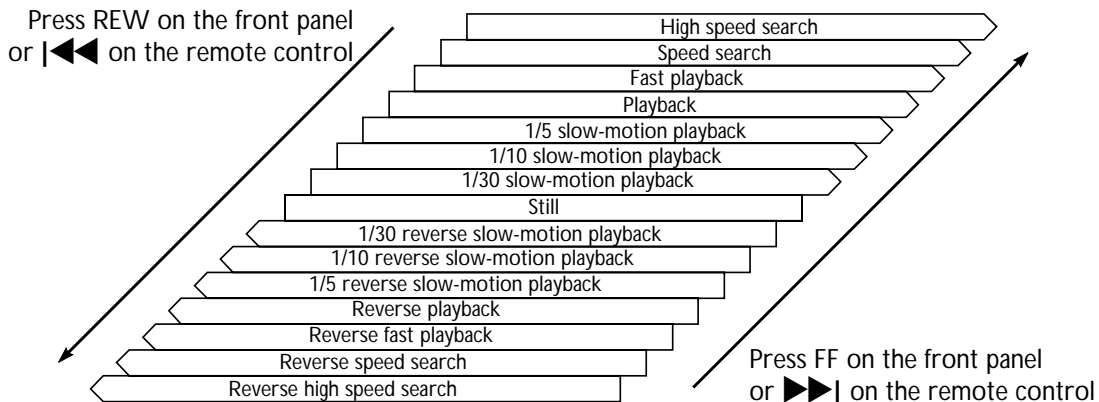

### Still adjustment

Sometimes during still frame, the picture may vibrate or shake. To correct this problem, press CHANNEL on the front panel until the vibration is reduced or stops. Side-to-side vibration cannot be corrected.

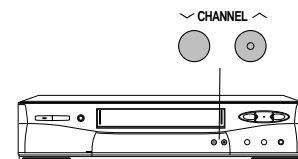

### Double speed playback

You can see the contents of the videotape in double speed playback.

- 1 While the VCR is playing a tape, press INPUT/X2. You'll see the picture in double speed playback. A certain amount of noise in the picture is normal.
- 2 To resume normal playback, press PLAY.

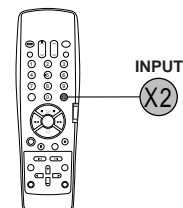



## Advanced Features

### Adjusting the Tracking

#### automatic tracking

Your VCR automatically adjusts the tape to give you the best quality picture. When you start playback of a newly inserted tape, the DIGITAL TRACKING light (D) will flash, showing that the VCR is adjusting the picture. When the VCR has finished adjusting the picture, the DIGITAL TRACKING light will shine steadily.

A certain amount of "noise" in the picture or sound is normal while the VCR is tracking a tape.

#### manual tracking

From time to time, you might play a tape that has excess noise in the picture, often looking like vibration or interference at the top or bottom of the screen. To correct the picture, you have to manually track the tape.

- 1 While the tape is playing, press CHANNEL on the front panel until the picture is clear of excess noise.
- 2 To continue automatic tracking, press both front panel CHANNEL buttons at the same time. Automatic tracking will also resume when you eject the tape.

#### slow tracking

Slow tracking is used to adjust the playback quality during slow motion playback and still frame. You can only use slow tracking if your tape was recorded in extended play (EP) speed. To adjust the slow tracking, put a tape into slow motion, then press CHANNEL on the front panel until the best picture is obtained.

### Time Counter

Your VCR has a time counter that shows the amount of time the tape has run in hours, minutes, and seconds. This counter is useful when you want to find specific points on a tape. The counter will not work when playing blank tapes or on blank sections of tape, or when the VCR's power is off.

#### setting the counter

To set the counter to "0H00M00S," press CANCEL on the remote control.

You cannot reset the counter if you are using the VCR's menus.

The counter will reset to "- H - - M - - S" when you eject a tape. When you load a tape again, the counter will display "0H00M00S".

D (digital tracking) light

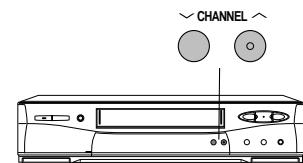
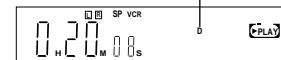

Time counter

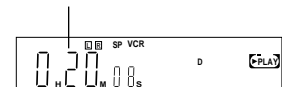

# Advanced Features

## Searching Techniques

Your VCR lets you search through a tape in a number of ways. These include:

- Quick search (CM skip)** -- 30 second intervals
- Speed search** -- visually search
- Counter zero stop** -- direct to start of recording
- Index search** -- find specific index points

### Quick search (CM skip)

Quick search lets you skip over the tape you are playing in about 30 second intervals. It is designed so that you can quickly speed through any commercials you may have recorded. To do this:

- 1 Make sure that you have set the VCR/TV slide switch on the remote control to the VCR position.
- 2 While playing a tape, choose the desired search time by pressing a number button.

Number button	1	2	3	4	5	6
Search time	30 sec.	1 min.	1 min. 30 sec.	2 min.	2 min. 30 sec.	3 min.

The VCR will speed through the selected length of tape, then resume playback. This screen will show the search time and the gauge. Each mark on the gauge represents 15 seconds. The marks will disappear, one by one, every 15 seconds of the search time. You can select a search time up to 3 minutes.

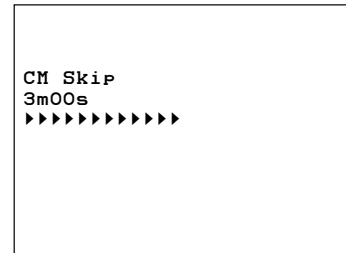

### Speed search

Use speed search to visually search through the contents of a videotape.

- 1 While playing a tape, press FF or REW on the front panel or on the remote control. You will see the picture as it fast forwards or rewinds. Noise bars may appear in the pictures.
- 2 If you press FF or REW and hold it down for about 1 second, the search speed will increase.
- 3 To resume normal playback, press FF or REW again quickly, or press PLAY.

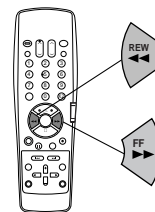

#### IMPORTANT

The fastest search speed that allows you to see the picture is about 30 times normal speed. It is normal for the number of noise bars on the screen to increase and roll from top to bottom as the visual search speed increases. Using speed search for long stretches of tape may cause the video heads to become dirty faster.

The fastest way to move through the tape is without a picture, which allows you to search up to 450 times normal speed. To do this, press STOP, then FF or REW. If you press and hold FF or REW for more than 2 seconds, the search speed will slow to 330 times normal speed.

In order to protect your tapes and the VCR heads, the Fast Forwarding/Rewinding Speed will be slower than 450x under the following conditions:

- 1 Use of tapes shorter in length than T-120 (for example, T-30, T-60, T-90).
- 2 Activating fast forwarding or rewinding from the middle of the tape.

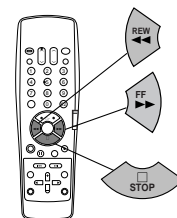

## Advanced Features

### Counter zero stop

Counter zero stop allows you to quickly access the beginning of a recorded or playback section of a tape. The counter zero stop will automatically fast forward or rewind the tape to "0H00M00S" and stop.

- 1 Press CANCEL on the remote control at the point you wish to locate later. The counter will reset to "0H00M00S".
- 2 When you wish to return to the point specified in step 1, press AUDIO/VIDEO on the remote control. The function menu appears on your screen. Press AUDIO/VIDEO until the Counter zero stop function appears.
- 3 Press ENTER to start the counter zero stop.

The VCR will automatically search to the counter "0H00M00S" and then stop. The VCR may stop slightly before or after the counter "0H00M00S".

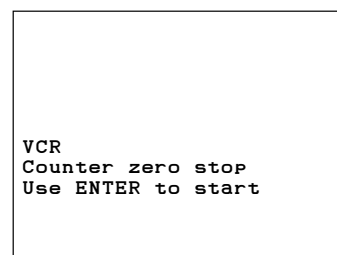

### Index search

Index search is a way to find specific points on a tape. Before using index search, index marks are placed at important places on a tape. Index search is used to find these marks. Index marks are added automatically whenever your VCR starts a new recording; you can also add index marks manually at any point during recording.

#### automatic index marks

Whenever recording is begun from the STOP mode, an index mark is automatically added to the tape. A message will indicate that the mark is being recorded.

Index marks are not added when you press PAUSE to begin recording from the record-pause mode.

#### manual index marks

To add an index mark yourself, press REC on the remote control while a tape is recording.

Index marks must be added at least one minute apart.

- 1 When the tape is stopped, press INDEX ►► to begin a forward search; press INDEX ◄◄ to search in reverse. The VCR will fast forward or rewind and index search display appears on the TV.

Once the VCR finds an index mark, it will begin playing back the tape from that point.

- 2 You can press INDEX ►► or INDEX ◄◄ buttons up to 19 times to search for that many index marks. For example, to find the third index mark ahead, press INDEX ►► three times. The on-screen display will count down the number of marks passed before playback begins.
- 3 To cancel index search, press PLAY or STOP.

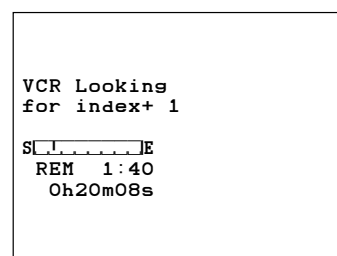
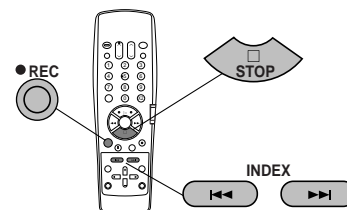

## Advanced Features

### repeat playback

You can playback a section of tape over and over using repeat playback. The tape will play until the next index mark, rewind to the previous index mark, and resume playing. If there is only one index mark on the tape, then the VCR will play or rewind to that mark and resume playback. If there is no index mark, the entire cassette will repeat.

- 1 Press AUDIO/VIDEO on the remote control to display the function menu. Press AUDIO/VIDEO until the Repeat play function appears.
- 2 To start the playback, press ENTER.  
When the VCR encounters the next mark or the end of the tape, it will automatically rewind to the previous mark and begin playback again. The VCR will also search for a blank section of tape. If the VCR encounters any blank sections longer than 4 seconds in length, the repeat playback will begin.
- 3 Press STOP to cancel the repeat.

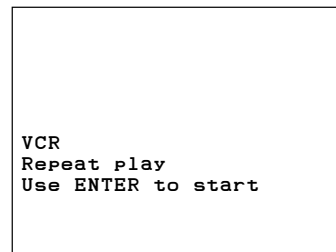

## Using PrograManager

PrograManager feature allows you to memorize the channel, month, date, hour and minutes of the programs you have recorded, and displays the list to confirm the contents of the tapes or to search the program you want to playback.

The recorded contents of any recording mode (normal / timer / OTR / OTR<sup>2</sup>) will be memorized in the VCR when the program is recorded for more than 5 minutes in SP mode, 15 minutes in EP mode. Before ejecting the tape, you have to set the tape number for that tape, and then the VCR memorizes the contents of it. This memorized data will be displayed and be used repeatedly when this tape is loaded again and its tape number is entered.

The VCR can memorize the contents up to 10 tapes (12 programs per tape at the maximum). You can enter or erase the contents of each tape.

If you set the PrograManager in the Customize Choices menu to **AUTO**, the screen to decide whether you set the tape number will appear when the tape is loaded. To avoid forgetting to set the tape number, this screen will reappear when the tape is ejected and its tape number is not set. See page 50 for more information on auto mode.

### Memorizing the contents of the tape of which data is memorized for the first time

If it is the first time you memorize the data for that tape, you have to set the tape number before ejecting the tape. Once the tape number has been set, the contents of that tape will be memorized automatically when ejecting the tape. You can set the tape number either before or after recording.

#### IMPORTANT

Make sure that the clock has been set correctly before memorizing the contents of the tape.

#### when recorded without setting the tape number

- 1 After the recording is finished, with the recorded tape loaded, press MENU on the remote control. VCR Main Menu appears. Press the ADJUST buttons to select PrograManager. Press ENTER.

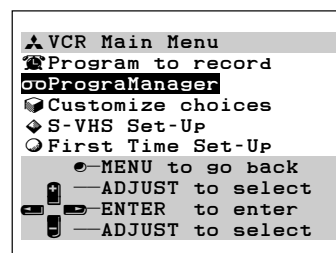

## Advanced Features

- The screen for selecting the data to display will appear. Press the ADJUST buttons to select Display current data and press ENTER.

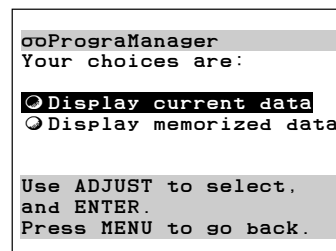

- The contents of the tape that is currently loaded will appear. Press INPUT.

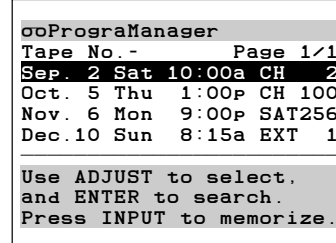

- The screen for selecting the tape number will appear. Press the number button that corresponds to the desired tape number (for example, no.0). Press ENTER.

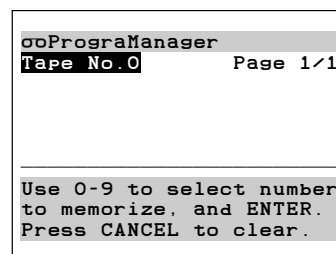

- The message to confirm the selected tape number will appear. Press ENTER to enter the displayed number. The contents of that tape will be memorized for the selected tape number and the screen will be turned off.

If the data of the recorded program already exists for the selected tape number, the data that is memorized previously will be erased.

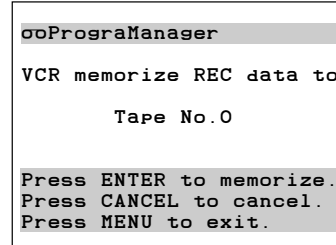

### setting the tape number before the recording begins

- Load the tape. Press MENU on the remote control. VCR Main Menu appears. Press the ADJUST buttons to select PrograManager. Press ENTER.

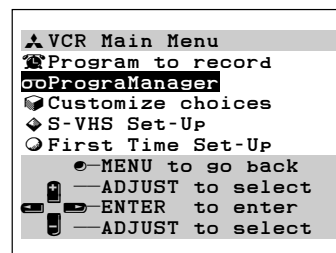

- The screen for selecting the data to display will appear. Press the ADJUST buttons to select Select Tape No. and press ENTER.

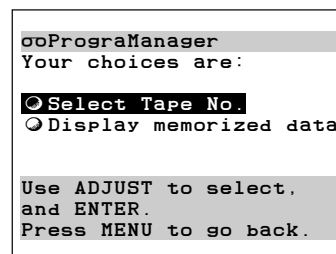

## Advanced Features

- The screen for selecting the tape number appears. Press the number button that corresponds to the desired tape number (for example, no.0). Press ENTER.

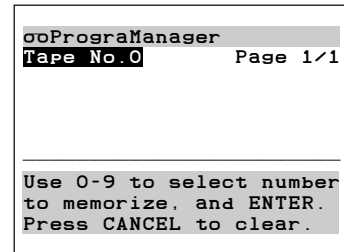

- The message to confirm the selected tape number will appear. Press ENTER to enter the displayed number. The contents of the tape that is currently loaded will be displayed. Press MENU to turn the menu off.

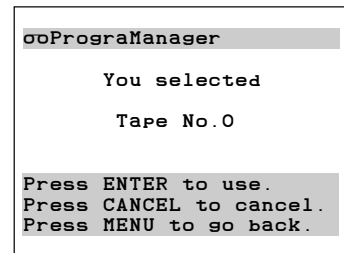

- Record the program. The contents of that tape will be memorized automatically when you eject the tape.

### Memorizing the contents of the recorded programs in addition to previously memorized programs

- Load the tape of which contents are memorized.
- Press MENU on the remote control. VCR Main Menu appears. Press the ADJUST buttons to select PrograManager. Press ENTER.

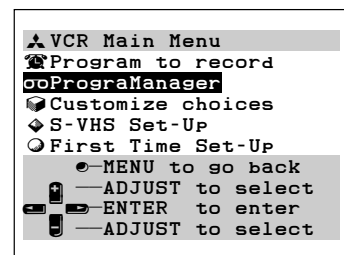

- The screen for selecting the data to display will appear. Press the ADJUST buttons to select Display memorized data and press ENTER.

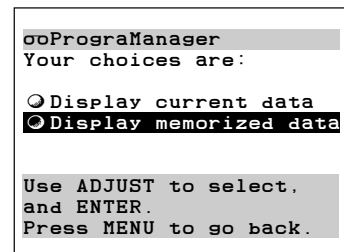

- The contents of the tape that is memorized as No.0 will be displayed. Press the number buttons to enter the tape number of the loaded tape; for example, tape no. 3.

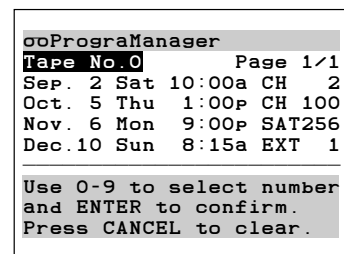

- Press ENTER while the contents of the selected tape number is displayed.

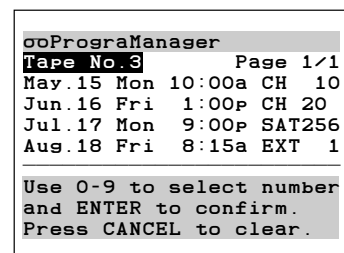

## Advanced Features

- The message to confirm the selected tape number will appear. Press ENTER to enter the displayed number.

```
ooPrograManager
You selected
Tape No.3
Press ENTER to use.
Press CANCEL to cancel.
Press MENU to go back.
```

- The contents of the selected tape number will be displayed as the data of the tape currently loaded. Press MENU to turn the menu off.
- Record the program. The newly recorded contents will be added automatically to the contents which is already memorized when you eject the tape.

```
ooPrograManager
Tape No.3 Page 1/1
May.15 Mon 10:00a CH 10
Jun.16 Fri 1:00p CH 20
Jul.17 Mon 9:00p SAT256
Aug.18 Fri 8:15a EXT 1
Use ADJUST to select,
and ENTER to search.
Press INPUT to memorize.
```

### Searching the memorized program

- Load the tape of which contents are memorized.
- Press MENU on the remote control. VCR Main Menu appears. Press the ADJUST buttons to select PrograManager. While the tape is stopped, press ENTER.

```
▲ VCR Main Menu
* Program to record
ooPrograManager
Customize choices
◆ S-VHS Set-Up
○ First Time Set-Up
  ○ MENU to go back
  + —ADJUST to select
  - —ENTER to enter
  | —ADJUST to select
```

- The screen for selecting the data to display will appear. Press the ADJUST buttons to select Display current data and press ENTER.

```
ooPrograManager
Your choices are:
○ Display current data
○ Display memorized data
Use ADJUST to select,
and ENTER.
Press MENU to go back.
```

- The contents of the tape that is currently loaded appears. Press ADJUST buttons to select the program you want to playback. Press ENTER.

```
ooPrograManager
Tape No.- Page 1/1
Sep. 2 Sat 10:00a CH 2
Oct. 5 Thu 1:00p CH 100
Nov. 6 Mon 9:00p SAT256
Dec.10 Sun 8:15a EXT 1
Use ADJUST to select,
and ENTER to search.
Press INPUT to memorize.
```

- The screen will be turned off and the VCR will begin to search. The display to the right will appear, showing that the VCR is searching the selected program. Once the VCR finds that program, it will begin playback.

```
VCR looking
for program
```

# Advanced Features

## Confirming/erasing the memorized data

- 1 Press MENU on the remote control. VCR Main Menu appear. Press the ADJUST buttons to select PrograManager. Press ENTER.
- 2 The screen for selecting the data to display will appears. Press the ADJUST buttons to select Display memorized data and press ENTER.
- 3 The contents of the tape that is memorized as No.0 will be displayed. Press the number buttons to enter the tape number you want to display; for example, tape no. 3.
- 4 When you want to erase the data, press CANCEL while the contents of the tape that you want to erase is displayed.
- 5 The message to confirm whether to erase the data on the selected tape number will appear. Press ENTER to erase. The data of that tape will be erased and the display will return to the screen for setting the tape number.

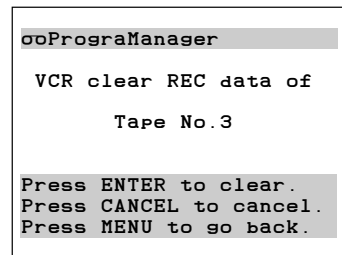
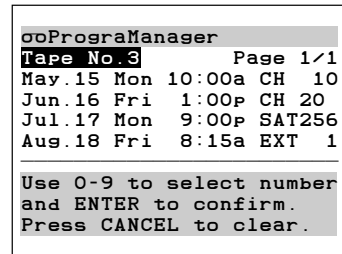
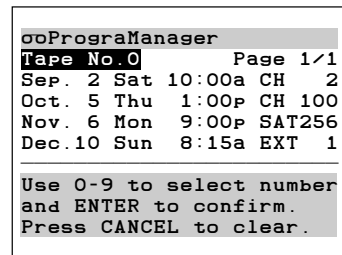
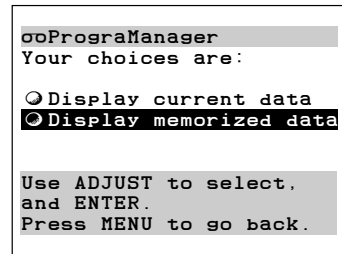
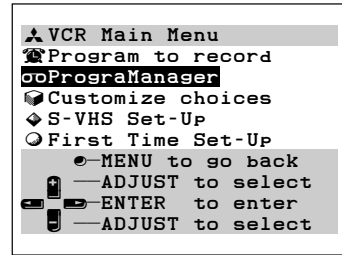

**IMPORTANT**

If the tape number of the tape to be erased is the same number for the tape currently loaded, the contents of the tape currently loaded will also be erased.



## Advanced Features

### Displaying the Time Gauge and the Remaining Time

The time gauge is a graphic representation of your position on a video tape. The left side of the gauge is the tape start (S), and the right side is the tape end (E). For a T-120 length tape played at standard (SP) speed, each mark on the gauge represents about 15 minutes. The remaining time display shows the time, in hours and minutes, left until the end of a tape.

**the time gauge and the remaining time automatically appear during:**

fast forward and rewind (from a stopped tape)  
counter zero stop  
index searches,  
rewinding for repeat playback  
Turn off the time gauge and the remaining time by pressing DISPLAY twice.

**to make the time gauge and the remaining time appear:**

Press DISPLAY once. The time gauge and remaining time appear on the TV screen, and the remaining time appears on the front panel display. They disappear after 4 seconds when playing a tape.

To turn off the display, press DISPLAY twice.

#### IMPORTANT

The time gauge and remaining time work by detecting control signals on recorded tapes. Therefore they do not function while playing blank tapes.

The remaining time display may not show the correct remaining time if the **Tape** function is incorrectly set, if you are using speed search, if you are using a special length cassette (such as T-10 length), or if you are using an S-VHS-C or a VHS-C tape with an adapter. The remaining time display may not work correctly depending on your tape.

### Displaying the Current Time

The current time is shown in the front panel display or the TV screen. If you have not set the clock, or if there has been a power failure of longer than 30 minutes, the display will show - : - . The current time will be displayed when the VCR is off. To see the current time when the VCR is on:

- 1 Press DISPLAY twice. The counter will be replaced by the current time.
- 2 To turn off the current time, press DISPLAY again.

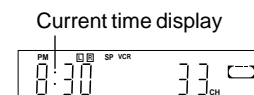
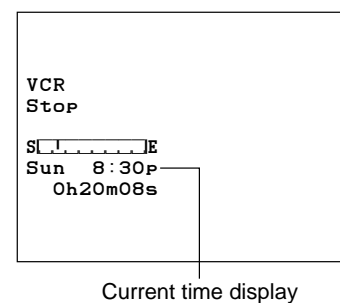
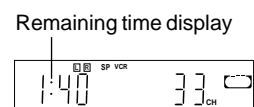
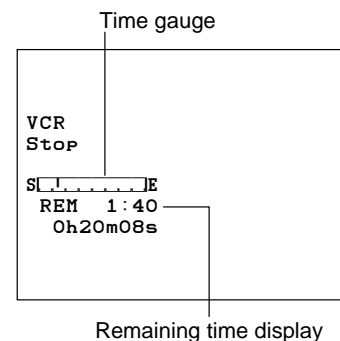

# Advanced Features

## Customize Choices Menu

In the Customize Choices menu are 7 options that you can set. For each of the 7 options, start with these 2 steps:

- 1 Press MENU on the remote control. VCR Main Menu appears on your TV.
- 2 Use the ADJUST buttons on the remote to select Customize choices. Press ENTER.

### IMPORTANT

Customize choices menu consists of two pages. To display the next page, use ADJUST buttons to select Go to next page and press ENTER. To go back to the previous page, use ADJUST buttons to select Back to previous page.

### Video mute

When you turn video mute ON, any blank section of tape or many stations with a weak signal will be replaced by a blue screen. The sound will also be turned off. When you would like to try to tune in on a weak station, turn video mute OFF.

- 3 Complete steps 1 and 2 above. Customize choices menu appears. Use the ADJUST buttons to select Video mute. Press ENTER to set video mute to ON or OFF.
- 4 Press MENU twice to turn off the menus.

### IMPORTANT

Video mute function may not work properly when you playback a section of a tape where only audio signals are recording.

### Auto power save (auto-off)

When the Auto Power Save feature is turned on, the VCR will automatically turn off after remaining idle for 30 minutes. If a control, such as a menu function or channel selection, is used or if there is a tape playing or being recorded, the VCR will remain on.

- 3 Complete steps 1 and 2 above. Customize choices menu appears. Use the ADJUST buttons to select Auto power save. Press ENTER to set to ON.
- 4 Press MENU twice to turn off the menus.

### IMPORTANT

When viewing broadcast stations through the VCR, 3minutes→Power off will appear on the TV screen three minutes before the VCR power turns off. The display will count down the number of minutes until the VCR turns off. If you want to continue using the VCR, press any of the buttons.

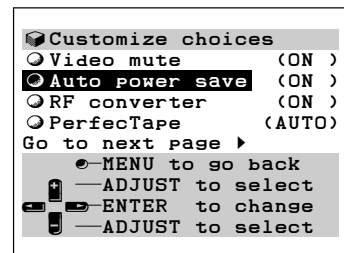
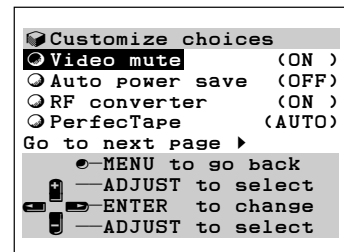
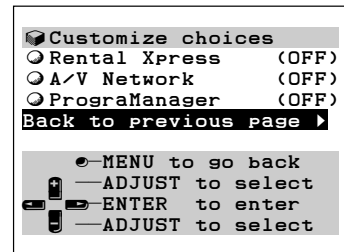
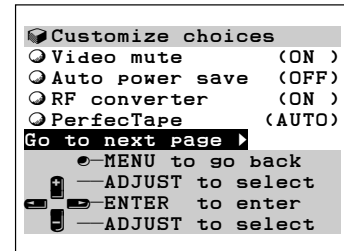
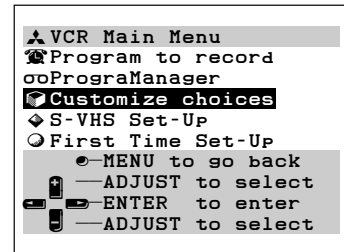

## Advanced Features

### RF converter

If your TV has audio and video inputs, turn the RF converter OFF. If your TV does not have audio and video inputs, keep the RF converter set to ON. It is preset by the factory to ON.

- Complete steps 1 and 2 on the previous page. Customize choices menu appears. Use the ADJUST buttons to select RF converter. Press ENTER to select ON or OFF.
- Press MENU twice to turn off the menus.

#### IMPORTANT

If the RF converter is set to ON, you aren't required to press VCR/TV to play a tape or to use VCR menus. The VCR light will automatically light up when you press PLAY or MENU. Be sure to set the TV to the video channel (See page 10).

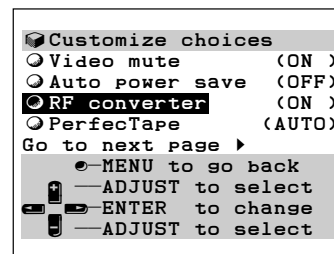

### PerfectTape®

PerfectTape® is an exclusive Mitsubishi feature that tests the quality of video tapes you will record on. After each test, the VCR will adjust its internal circuitry in order to make the best possible recording on your tape.

#### setting up PerfectTape®

You can set up PerfectTape® to function two ways.

If you want the VCR to automatically test any non-recorded tapes when the tape is loaded, select AUTO.

If you do not want the VCR to automatically test tapes, select MANUAL. PerfectTape® will now function only when you start a test. Any tape with the erasure prevention tab intact can be manually tested.

It will not automatically test recorded tapes – you must choose to test those yourself.

- Complete steps 1 and 2 on the previous page. Customize choices menu appears. Use the ADJUST buttons to select PerfectTape.
- Press ENTER to set PerfectTape to AUTO or MANUAL.
- Press MENU twice to turn off the menus.

#### using PerfectTape® automatically

- Load a tape that has not been recorded into the VCR.

The VCR will display the testing status screen. When testing, the VCR records for one second, then evaluates the recording it made. The entire test takes about 8 seconds. During this time, the PT light on the front panel will flash. If you wish to cancel the test, press STOP on the remote while the PT light is still flashing.

When the test is done, the VCR will display the rating of your tape for 8 seconds. On the front panel, the PT light will shine steadily, indicating that the VCR has set its internal circuitry to make the best possible recording on this tape.

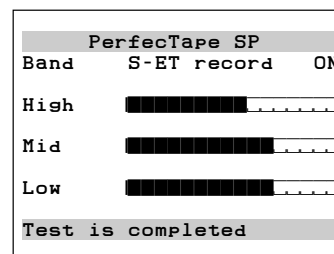
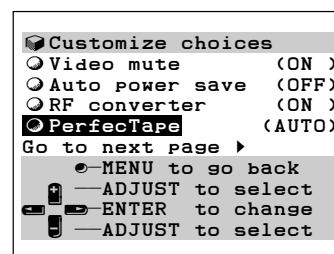

## Advanced Features

If you would like to know whether your VHS tape is suitable for S-ET recording, set the S-ET record in the S-VHS Set Up menu to **AUTO** then test the VHS tape. If the tape is suitable, S-ET record: ON is shown on the screen and the tape will record in S-ET mode. If it is not suitable for S-ET recording, S-ET record: OFF is shown on the screen and the tape will record in VHS format.

### using PerfectTape® manually

- 1 Load a tape that has its erasure prevention tab intact into the VCR.
- 2 Find a portion of the tape that is OK to record over; this feature will record over one second of your tape.
- 3 Press AUDIO/VIDEO on the remote control. Function menu appears. Press AUDIO/VIDEO until the PerfectTape function appears.
- 4 Press ENTER on the remote to begin the test. During this time, the PT light on the front panel will flash. To cancel the test, press STOP on the remote while the PT light is still flashing.

When the test is finished, the VCR will display the rating of your tape for 8 seconds. Turn off the display by pressing STOP on the remote control.

If you would like to know whether your VHS tape is suitable for S-ET recording, set the S-ET record in the S-VHS Set Up menu to **AUTO** then test the VHS tape. If the tape is suitable, S-ET record: ON is shown on the screen and the tape will record in S-ET mode. If it is not suitable for S-ET recording, S-ET record: OFF is shown on the screen and the tape will record in VHS format.

If you wish to erase the settings, eject the tape. The settings will also be erased if you press TIMER RESET or if the VCR loses power. After the test is finished, the PerfectTape function will not appear unless the tape is ejected.

### Rental Xpress

Rental Xpress is a feature, when activated, that will automatically rewind the tape to the beginning, eject and power off the VCR, after it has reached the blank section of 30 seconds or longer on any rental tape (or any tape with the erasure prevention tab removed). To activate this feature:

- 3 Complete steps 1 and 2 on page 42. Customize choices menu appears. Use the ADJUST buttons to select Go to next page. Press ENTER.
- 4 Press the ADJUST buttons to select Rental Xpress. Press ENTER to select ON or OFF.
- 5 Press MENU twice to turn off the menus.

#### IMPORTANT

While the VCR is rewinding to the beginning of the tape, you cannot use repeat playback, counter zero stop and index search.

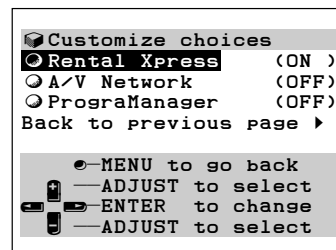
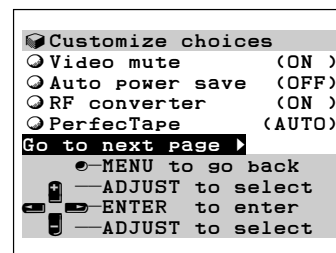
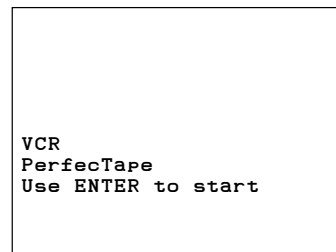

## Advanced Features

### Active A/V Network™

Active A/V Network allows you to directly operate many of the combined functions of certain Mitsubishi TVs and your VCR at the press of one button.

If you have a Mitsubishi TV with Active A/V Network, check the following:

- your VCR must be connected to External 1 (EXT-1) or Input-1 of a Mitsubishi TV with Active A/V Network
- video mute must be ON
- Active A/V Network setting on your TV must be set to ACTIVE (see your TV's owner's guide for information)
- VCR remote mode set to VCR-A (See page 54)
- The A/V Network must be connected as shown on page 9

To turn on the Active A/V Network on your VCR:

- 3 Complete steps 1 and 2 on page 48. Customize choices menu appears. Use the ADJUST buttons to select Go to next page. Press ENTER.
- 4 Use the ADJUST buttons to select A/V Network. Press ENTER to set A/V Network to ACTIVE.
- 5 Press MENU twice to turn off the menus.

### what the Active A/V Network does

The Active A/V Network makes it easier and faster to use the VCR's Quick Program, MENU, and Play commands.

#### When you press QUICK PROGRAM/VCR Plus+ to begin programming:

- Active A/V Network turns on your VCR and brings it to the VCR Plus+ Program to record Menu.
- Active A/V Network turns on your TV if it is off, and switches the TV to EXT-1 or INPUT-1.

#### When you press QUICK PROGRAM/VCR Plus+ to end programming:

- Active A/V Network turns off your VCR (unless a tape is currently playing or recording).
- Active A/V Network returns your TV to the channel it was on before, or turn it off (if it was off originally).

#### When you press MENU on the remote:

- Active A/V Network turns on your VCR and brings up the VCR Main Menu screen.
  - Active A/V Network turns on the TV, set to EXT-1 or INPUT-1.
- Some models of TVs may not turn on when you press MENU.

#### When you press PLAY on the remote:

- Active A/V Network turns on your VCR and begins playing the tape.
- Active A/V Network turns on the TV, set to EXT-1 or INPUT-1.

#### When you turn off your TV:

- Your VCR turns off, unless it is playing or recording.

Active A/V Network can also affect your VCR when some selected TV's PIP function is used. Active A/V Network can set your VCR's clock if your TV is equipped with StarSight®. See your TV Owner's Guide for more information.

#### IMPORTANT

When using Active A/V Network, always point your remote control at your television, not at your VCR.

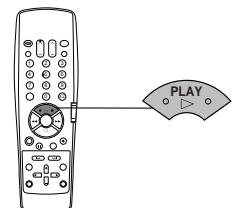
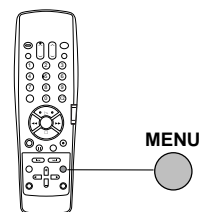
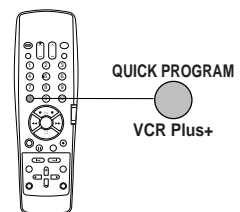
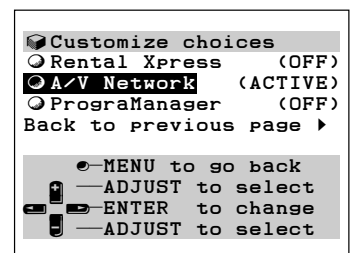
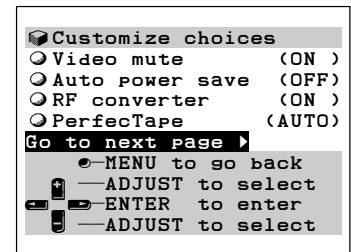

## Advanced Features

### PrograManager (auto mode)

To avoid failing to memorize the contents of the tape caused by not setting the tape number, the screen to decide whether you set the tape number will appear when the tape is loaded if you set the PrograManager in the Customize Choices menu to **AUTO**. This screen will reappear when the tape is ejected and the tape number for that tape is not set. If you do not want this screen to appear, set it to **OFF**.

- 3 Complete steps 1 and 2 on page 48. Customize choices menu appears. Use the ADJUST buttons to select Go to next page. Press ENTER.
- 4 Press the ADJUST buttons to select PrograManager. Press ENTER to select AUTO or OFF.
- 5 Press MENU twice to turn off the menus.

#### loading the tape when the PrograManager in the Customize Choices menu is set to **AUTO**

- 1 Load the tape. The screen to decide whether you set the tape number will appear. Select Yes when you want to set the tape number. Press ENTER.
- 2 The contents of the tape that is memorized as No.0 will be displayed. Press the number buttons to enter the tape number you want to set.
- 3 The message to confirm the selected tape number will appear. Press ENTER to enter the displayed number. The menu will be turned off.

#### unloading the tape when the PrograManager in the Customize Choices menu is set to **AUTO**

- 1 When unloading the tape of its tape number is not set and the program has been recorded, the screen will appear to decide whether you memorize the recorded data. Select Yes when you want to memorize the data. Press ENTER.
- 2 The screen for selecting the tape number appears. Press the number button that corresponds to the desired tape number. Press ENTER.
- 3 The message to confirm the selected tape number will appear. Press ENTER to enter the displayed number. The screen will be turned off.

If the data of the recorded program already exists for the selected tape number, the data that is memorized previously will be erased.

If the tape number of that tape has already set, the recorded data will be memorized on that tape number automatically while ejecting. Therefore, this screen will not appear.

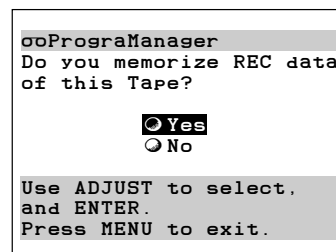
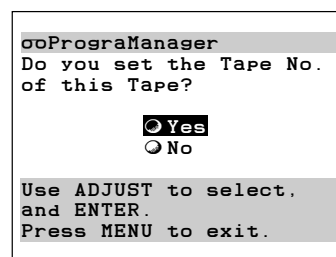
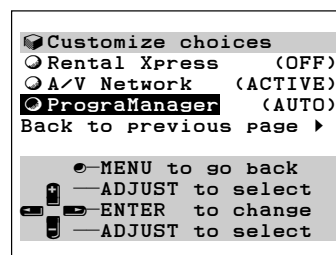
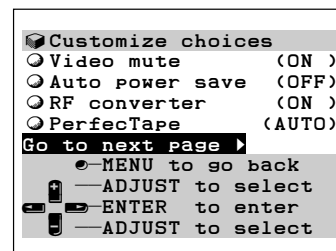

## Advanced Features

### Advanced Options

#### Using the remote control to operate your TV

The HS-U776 remote control can operate many of the frequently-used functions of your TV. You only need one remote to operate both your VCR and TV.

The HS-U776 remote control is pre-set to operate Mitsubishi televisions, but it can also operate TVs from other manufacturers. To set your remote control for your particular brand of television, follow these instructions.

#### setting up your remote control to operate your TV

- 1 Turn off your TV.
- 2 On the HS-U776 remote control, set the VCR/TV slide switch to TV position.
- 3 While holding in SP/EP, press the brand code button listed that corresponds to the brand of your TV.
- 4 Press TV POWER on the HS-U776 remote control. Once your TV has turned on, your remote is set up to operate your brand of TV.

If your TV does not turn on, repeat step 3 using the next code listed for the brand of your TV.

If none of the codes listed for the brand of your TV work, then repeat step 3 several times, using a different code button until one works. The possible code buttons are: 0, 1-9, MUTE, VOLUME  $\wedge$ ,  $\vee$ , CHANNEL  $\wedge$ ,  $\vee$  and INPUT.

You do not need to perform this set-up again until you change the batteries, set up your remote for another brand of television, or you get a new TV.

Once you have correctly set your remote control to operate your TV, you will be able to use the TV POWER, CHANNEL, VOLUME, and number buttons to operate your TV.

Brand of TV	Brand code buttons
Mitsubishi	1, 2, 3
Fisher	0
G.E.	VOLUME $\wedge$
Goldstar	2, 9
Hitachi	8
JVC	MUTE
Magnavox	4
NEC	2, 9
Panasonic	CHANNEL $\wedge$ , $\vee$
Pioneer	6
Philips	4
Proscan	VOLUME $\wedge$
Quasar	CHANNEL $\vee$
RCA	VOLUME $\wedge$
Sanyo	0
Sharp	3, 5
Sony	VOLUME $\vee$
Toshiba	7
Zenith	INPUT

#### IMPORTANT

Because of variations among models, some or all buttons may not work, or they may operate different functions than expected for your particular TV. If this occurs, you may need to use your TV remote control.

Sometimes manufacturers will change the remote control codes for their products, or they will use more than one code. If this is the case, your remote may not be able to control your TV.

When you replace the batteries in your remote, the remote may return to its initial setting (code button 1). Repeat the steps above to reset your remote control. If you enter a new code, the previous code will be erased.

#### operating your TV with the HS-U776 remote control

- 1 Set the VCR/TV slide switch to TV position on the HS-U776 remote control to tell the remote that you want to operate the TV.
- 2 Point the remote control towards the TV and press the desired buttons. To once again control the VCR, set the VCR/TV slide switch to VCR position.

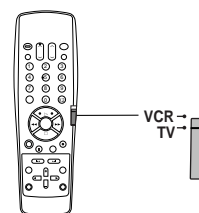

## Advanced Features

### To program the remote control operational setting

The HS-U776 has two remote control operational settings, VCR-A and VCR-B. These are available so you may separately control two Mitsubishi VCRs that are placed close together. The VCR-A setting can be used to operate any other Mitsubishi VCR introduced since 1986. Setting the HS-U776 to VCR-B will allow the HS-U776 be operated without the VCR responding at the same time.

### To program the HS-U776 and the remote to VCR-B

For VCR:

- 1 Make sure the HS-U776 is plugged in but turned off. On the VCR front panel, press REC SPEED and REW at the same time. To confirm that the VCR responds to VCR-B signals, **b** appears on the front panel display.

For remote:

- 2 On the remote, make sure the VCR/TV slide switch is in the VCR position, then press VCR/TV and number "2" at the same time. The remote will now send VCR-B signals.

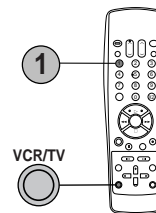
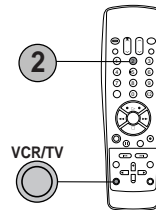
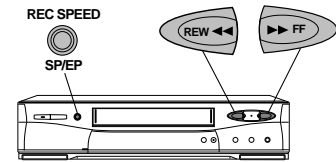

### When you wish to operate the other VCR

- 1 On the remote, with the VCR/TV slide switch in the VCR position, press VCR/TV and the number "1" at the same time. The remote will now send VCR-A signals.

### To reprogram the HS-U776 to respond to VCR-A signals again

- 1 Make sure the HS-U776 is plugged in but turned off. On the VCR front panel, press SP/EP and FF at the same time. To confirm that the VCR responds to VCR-A signals, **A** appears on the front panel display.

#### IMPORTANT

Some other models of Mitsubishi VCRs can respond to VCR-B signals. If your other VCR is one of these models, and you would like to program the other VCR to respond to VCR-B signals, refer to the owner's guide that came with the other VCR.

Some of the buttons may not function or they may operate different features than expected for the other VCR, particularly, those Mitsubishi VCR's that are more than 10 years old because Mitsubishi changes the codes from time to time.

## Child Lock

The child lock feature prevents others from using your VCR. To lock the VCR:

- 1 Press and hold down DISPLAY on the remote control for about 8 seconds. The LOCK light on the front panel display will light up.
- 2 To cancel the child lock, press and hold down DISPLAY for about 8 seconds, until the LOCK light on the front panel display goes out.



#### IMPORTANT

You can lock the VCR with the power off, even if the VCR is standing by for a programmed recording. If you lock the VCR with no cassette in it, the VCR will not accept a cassette.



# Location of Controls

## Remote Control

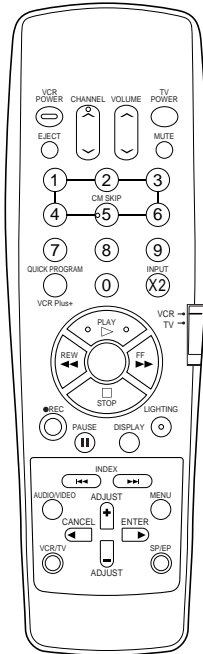

### VCR POWER

Turns the VCR on or off. If you have programmed the VCR to record, you need to turn the VCR off.

### EJECT

Ejects a tape.

### CHANNEL Up and Down

Selects next higher or lower channel in the VCR's or TV's channel memory.

### VOLUME Up and Down

Raises and lowers the sound of the TV.  
(Operates the TV only)

### TV POWER

Turns the TV on or off. You need to program your remote to operate your particular brand of television.

### MUTE

Turns off the TV sound. Press again to restore the TV sound to its previous volume. (Operates the TV only)

### Number buttons

Selects TV stations, enters PlusCode numbers.  
Sets quick search (CM skip) time.

### QUICK PROGRAM/VCR Plus+

Goes to VCR Plus+ Program to record menu.  
Exits the programming screen.

### INPUT/X2

Select between the antenna and any other video equipment that may be connected.  
Use double speed playback when playing a tape.

### PLAY ▷

Plays a tape.

### STOP ◻

Stops a tape.

### REW ◀◀

Rewinds a tape or reverse searches.

### FF ▶▶

Fast forwards a tape or fast forward searches.

### VCR/TV slide switch

Operates the VCR when set to the VCR position, the TV when set to the TV position. You need to program your remote to operate your particular brand of television.

### ● REC

Starts recording. While recording, adds manual index mark.

### PAUSE ||

Pauses a tape when recording.  
Freezes a frame when playing a tape.

### DISPLAY

Displays on the TV screen:

- Time elapsed on the tape
- Time left on the tape, current time
- Channel number and audio reception mode
- Audio channel(s) selected
- Source supplying the VCR with a signal
- If the VCR is stopped, playing, or recording

Turns the Child Lock on and off.

### LIGHTING

Lights up the PLAY, STOP, REW, FF buttons.

### INDEX ◀◀, ▶▶

Begins index search forward and backward.  
Controls the playback speed of a tape.

### AUDIO/VIDEO

Selects the audio and video settings to be adjusted.

### MENU

Displays the menus. Exits the menus.

### CANCEL

Cancels menu selections.  
Resets the counter display to "0H00M00S."

### ADJUST +, -

Selects and adjusts menu selections.

### ENTER

Enters menu selections.

### VCR/TV

Switches between the VCR's picture and the TV's tuner.

### SP/EP

Changes the recording speed. (SP is standard play; EP is extended play).

# Location of Controls

## Front Panel

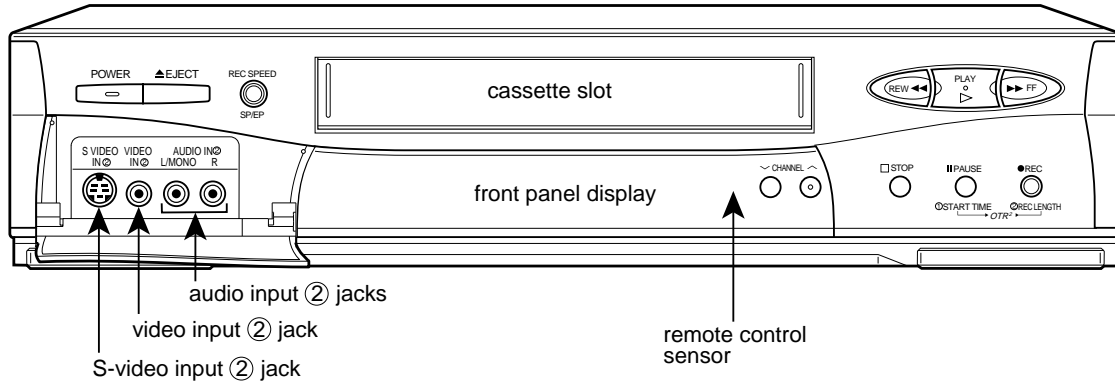

### POWER

Turns the VCR on or off.  
If you have programmed your VCR to record, turn off your VCR.

**EJECT**  
Ejects a tape.

**REC SPEED SP/EP**  
Changes the recording speed (SP is standard play; EP is extended play).

**S-video input (2) jack**  
Connect source here, such as a VCR or camcorder, to record or dub video.

**video input (2) jack**  
Connect source here, such as a VCR or camcorder, to record or dub video.

**audio input (2) jacks**  
Connect source here, such as a VCR or camcorder, to record or dub audio.

**cassette slot**  
Insert the video cassette tape here.

**front panel display**  
See the next page.

**remote control sensor**  
Receives signals from the remote control.  
Do not block it.

### CHANNEL

Changes channels.  
Adjusts tracking and picture vibration.

**REW** ◀◀  
Rewinds a tape or reverse searches.

**PLAY** ▶  
Plays a tape.  
Resumes normal playback from special effects.

**FF** ▶▶  
Fast forwards a tape or fast forward searches.

**STOP** ◻  
Stops a tape.

**|| PAUSE/① START TIME**  
Pauses a tape when recording.  
Freezes a frame when playing a tape.  
Sets the start time in OTR<sup>2</sup> recording.

**● REC/② REC LENGTH**  
Records to the end of the tape by pressing once.  
Sets the recording time for OTR recording by pressing repeatedly.

# Location of Controls

## Front Panel Display

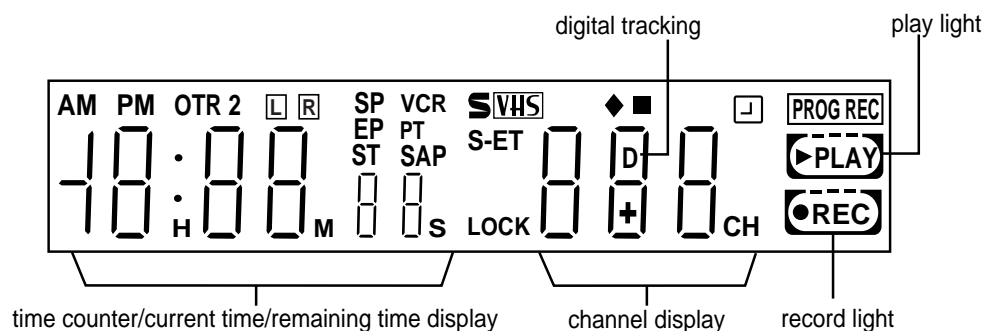

### OTR light : OTR

Lights up during recording the program with One-Touch Recording.

### OTR 2 light : OTR 2

Lights up during setting up, the delay time of Standby One-Touch Recording.

### LR indicator : L R

L indicates that you are listening to the left channel of a stereo track, R indicates that you are listening to the right channel of a stereo track.

### tape speed lights : SP, EP

Indicates tape speed.  
SP is standard play; EP is extended play.

### stereo indicator : ST

Indicates a stereo TV channel.

### VCR light : VCR

Indicates that the picture is controlled by the VCR.

### PerfectTape® light : PT

Flashes when PerfectTape test is in progress.  
Stays lit when test is complete.

### SAP indicator : SAP

Indicates that channel has a Separate Audio Program, or SAP.

### S-VHS indicator : S-VHS

Lights up when the S-VHS tape or no tape is loaded and the S-VHS record is set to AUTO, when you play or record in Super-VHS (S-VHS).

### S-ET indicator : S-ET

Lights up when the VHS tape is loaded and the S-ET record is set to ON, when you play or record in S-ET mode.

### lock light : LOCK

Lights up when Child Lock feature is in use.

### PRIMESTAR® light : ◆

Lights up when VCR has selected channels from a PRIMESTAR receiver.

### cable tuning light : ■

Lights up when VCR is set to receive cable broadcasts.

### programmed recording light : □ PROG REC

Lights up when VCR is off and it is programmed to record.

### play and record lights : ▶PLAY ●REC

These light up when the VCR is playing a tape or recording. The cassette status symbol (□) will light up when a tape is in the VCR. The dashes in the center of the symbol simulate the movement of the tape when playing and recording.

### time counter/current time/remaining time display

This area displays:

- current time
- time counter showing how long tape has run
- time remaining on the tape

### channel display

Displays cable channel, broadcast channel, satellite channel, or input.

### digital tracking light : D

Flashes when VCR is adjusting the tracking.  
Glow steadily when tracking is finished.  
If tracking is adjusted manually, it turns off.

# Location of Controls

## Rear Panel Jacks

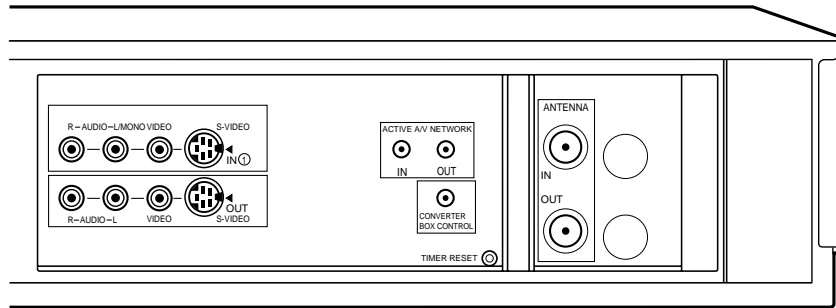

### VIDEO Input and Output jacks

Yellow jacks for receiving (IN) and sending (OUT) video signals to a monitor TV or from another VCR.

The black jacks marked with "S-Video" can be used to connect televisions with S-Video jacks. ("S-Video jack" refers to a Separated Luminance-Chrominance (Y/C) jacks that conforms to the NTSC signal.)

### AUDIO Input and Output jacks

Red and white jacks for receiving (IN) and sending (OUT) audio signals. Red signifies the right channel, and white signifies the left channel. Stereo audio cables are also color coded red and white. If you are receiving or sending a mono (non-stereo) signal, you should use only the left (white) terminal.

### ACTIVE A/V NETWORK jacks

Connects the VCR to other Mitsubishi products with Active A/V Network or A/V Network jacks.

### CONVERTER BOX CONTROL jack

Connects IR Emitter to a cable box and/or satellite receiver.

### TIMER RESET

Erases all programmed recording settings and resets the clock. Use this button with care.

### ANTENNA IN jack

Attach an external antenna or cable to bring in an outside signal.

### ANTENNA OUT jack

Attach a coaxial cable to your TV to send out antenna/cable signals from the VCR to your TV.

# Trouble Checks

If your VCR malfunctions, try the following steps prior to contacting your Mitsubishi Dealer:

- 1 Check the **Trouble Checks** below to see if there is a solution to the current problem that you are experiencing.
- 2 If the problem is not addressed on the **Trouble Checks**, the safety circuits in the VCR may be in operation, thus please try the following: (the clock setting and the timer recording will be deleted.)
  - 1 If possible, press EJECT on the front panel and remove the tape.
  - 2 Press TIMER RESET on the rear panel with a pencil or a ball point pen.
  - 3 If a tape is not loaded, press POWER to turn the power on. If a tape is loaded, wait about 1 minute until the tape protecting function is completed, then press POWER.
- 3 You may also try the following procedure if the above steps did not resolve the problem. (All settings will be reset to the default settings.)
  - 1 Press POWER on the front panel continuously for about 8 seconds until the current time display on the front panel shows "- : - -".
  - 2 If a tape is not loaded, press POWER to turn the power on. If a tape is loaded, the tape protecting function will work and "99" will appear on the front pane display to begin count down. Wait about 1 minute until it reaches "00" to show the tape protecting function is completed, then press POWER.

If the problem with your VCR persists, contact your Mitsubishi dealer for help.

Problem	Try This...
The VCR won't turn on.	<ul style="list-style-type: none"><li>• Check the power cord and the AC outlet.</li><li>• Is the LOCK light ON? If so, press and hold DISPLAY on the remote for more than 8 seconds until the LOCK light turns off.</li></ul>
The VCR power is on but no controls work.	<ul style="list-style-type: none"><li>• Is the LOCK light ON? If so, press and hold DISPLAY on the remote for more than 8 seconds until the LOCK light turns off.</li><li>• Set the VCR/TV slide switch to VCR position.</li><li>• Press TIMER RESET on the rear panel.</li></ul>
You can't see the VCR's picture on your TV.	<ul style="list-style-type: none"><li>• Check the TV's input setting.</li><li>• Check to see that your VCR is not set to L1 or L2.</li></ul>
Poor picture when watching the VCR's tuner on your TV.	<ul style="list-style-type: none"><li>• Check to see if your TV is set to the correct channel or input.</li><li>• Check your TV's fine tuning, if using an older TV.</li><li>• Check your connections to make sure they are secure.</li></ul>
VCR REC button doesn't function.	<ul style="list-style-type: none"><li>• Check the erasure prevention tab on the tape cassette.</li></ul>
No picture during recording.	<ul style="list-style-type: none"><li>• Check the hook-up.</li><li>• Check to see if your TV is set to the correct channel or input.</li></ul>
VCR does not record TV program.	<ul style="list-style-type: none"><li>• Check the VCR tuning.</li><li>• Check the input selection on the VCR. Does the front panel display show L1 or L2? If so, switch it to tuner by pressing INPUT.</li></ul>
The VCR timer recording does not operate.	<ul style="list-style-type: none"><li>• Check that the programmed recording light lights up in the front panel display.</li><li>• Check the clock time.</li><li>• Make sure you have turned the VCR off before the start time.</li></ul>

## Trouble Checks

Problem	Try This...
Noise in the picture and distorted sound.	<ul style="list-style-type: none"><li>• Check the tracking control. Adjust manually if necessary.</li></ul>
Poor or no Hi-Fi sound.	<ul style="list-style-type: none"><li>• Check the monitor settings.</li><li>• Check the quality of the video tape.</li></ul>
Playback is noisy or "snowy".	<ul style="list-style-type: none"><li>• Try automatic head cleaning.</li><li>• Clean the video heads using a dry-type video head cleaning cassette. Do not use a wet-type head cleaning cassette, as it may damage your VCR. Excessive use of a cleaning cassette could shorten head life. Follow the cleaning instructions carefully.</li><li>• Have the VCR video heads cleaned by a qualified service technician.</li></ul>
VCR remote does not function.	<ul style="list-style-type: none"><li>• Check that remote mode of the VCR and your remote are set correctly (VCR-A or VCR-B).</li><li>• Check to see that the VCR/TV slide switch is set to the correct position.</li><li>• Change the batteries.</li></ul>
Your converter box or satellite receiver does not respond to any signals from the VCR's IR Emitter.	<ul style="list-style-type: none"><li>• Try moving the IR Emitter so that there is a clear line of sight between the Emitter and the box's remote sensor.</li><li>• Check that the IR Emitter is connected properly.</li><li>• Sometimes a cable box needs to be set by the cable company to receive signals. Contact your cable company.</li></ul>
The fast forwarding/rewinding speed is slow.	<ul style="list-style-type: none"><li>• In order to protect your tapes and the VCR heads, the Fast Forwarding/Rewinding Speed will be slower than 450x under the following conditions:<ol style="list-style-type: none"><li>1 Use of tapes shorter in length than T-120 (for example, T-30, T-60, T-90).</li><li>2 Activating fast forwarding or rewinding from the middle of the tape.</li></ol></li></ul>

# Specifications

FORMAT	S-VHS/VHS NTSC standard with Hi-Fi audio
VIDEO SIGNAL SYSTEM	EIA standard; NTSC color
RECORD/PLAYBACK SYSTEM	Video -- 4 heads Audio -- 2 Hi-Fi channels and 1 monaural audio control
ANTENNA	75-ohm external VHF/UHF combined antenna terminal
TUNER	181 channels capability VHF -- Channels 2 - 13 UHF -- Channels 14 - 69 CATV -- Channels 1-125
HORIZONTAL RESOLUTION	S-VHS -- more than 400 lines (SP) more than 400 lines (EP) VHS -- more than 220 lines (SP) more than 210 lines (EP)
SIGNAL-TO-NOISE RATIO	S-VHS -- more than 43 dB (SP) more than 43 dB (EP) VHS -- more than 45 dB (SP) more than 46 dB (EP)
COMB FILTER	Digital dynamic
TIMER PROGRAM CAPACITY	1-month programmable / 8 programs
MEMORY BACKUP TIME	approx. 30 minutes
MAXIMUM RECORDING TIME	120 min. with T-120 video cassette (SP) 360 min. with T-120 video cassette (EP)
REWIND TIME	approx. 48 seconds for T-120 cassette (full recorded tape)
POWER REQUIREMENT	120V AC, 60 Hz
POWER CONSUMPTION	25 Watts -- 4.0 Watts standby
DIMENSIONS	3-5/8 in Height x 16-3/4 in Width x 11-13/16 in Depth (93mm x 425mm x 300mm)
WEIGHT	8.8 lbs approx. (4.0kg)
SUPPLIED ACCESSORIES	1 set coaxial cable 1 set stereo audio/video cables 1 S-video cable 1 remote control with batteries 1 IR emitter

# Index

<b>A</b>		
A/V Network		
active .....	51	
connections to .....	9	
jacks .....	9, 58	
adding channels .....	16	
adjust button .....	55	
adjusting tracking .....	39	
advanced options .....	53	
playback controls .....	38	
antenna, connecting .....	5	
jacks .....	5, 58	
audio		
connecting a TV with inputs ..	6	
input, output jacks .....	56, 58	
monitor .....	26	
audio video functions		
button .....	55	
selecting .....	27	
using .....	26	
auto clock function .....	18	
auto power save .....	48	
auto speed programming .....	33	
<b>B</b>		
backup, memory .....	35	
batteries, installing .....	11	
<b>C</b>		
cable, connections to .....	5	
cable box, connections to .....	5	
cable tuning light .....	57	
cancel button .....	55	
cancel		
button .....	55	
recording in progress .....	30	
timer recording .....	35	
cassette slot .....	56	
cassette status symbol .....	57	
changing recording settings .....	34	
changing settings while		
programming .....	30	
channel(s)		
adding and deleting .....	16	
button .....	55, 56	
display .....	57	
memorize .....	13	
selecting .....	17	
child lock .....	54	
choosing a hookup .....	4	
clock setting .....	18	
CM skip .....	40	
connections to		
antennas .....	5	
A/V Network .....	9	
cable with or without box ..	5	
home theater receiver .....	8	
satellite receiver .....	7	
IR emitter .....	9	
TV w/audio video inputs .....	6	
converter box control jack ..	9, 58	
copying a tape .....	36, 37	
counter display .....	57	
counter zero stop .....	27, 41	
customize choices menu .....	48	

# Index

## D

daylight savings time ..... 19  
digital tracking light ..... 57  
display button ..... 55  
displaying current time ..... 47  
displaying time gauge ..... 47

## E

editing features ..... 36, 37  
eject button ..... 55, 56  
enter button ..... 55  
erasure, preventing tape ..... 21

## F

fast forwarding a tape ..... 12, 40  
FF button ..... 55, 56  
front panel buttons ..... 56  
front panel display ..... 56, 57

## H

head cleaning ..... 12

## I

important safeguards ..... 2  
index buttons ..... 55  
    techniques ..... 41  
input/X2 button ..... 55

## L

lighting button ..... 55  
loading tapes ..... 11  
location of controls ..... 55  
lock light ..... 54, 57  
lock VCR ..... 54  
LR indicator ..... 57

## M

memory backup ..... 35  
menu button ..... 55  
menus, using ..... 13  
mute button ..... 55

## N

number buttons ..... 55  
normal recording ..... 26

## O

one touch recording (OTR) .... 22  
    light ..... 57  
one touch recording, standby . 23  
    light (OTR 2) ..... 57

## P

pause button ..... 55, 56  
pausing a tape ..... 12  
PerfectTape® light ..... 57  
    using ..... 27, 49  
play and record lights ..... 57  
play button ..... 55, 56  
play a tape ..... 11  
Play PerfectTape ..... 27  
playback controls, advanced .... 38

power button ..... 55, 56  
PRIMESTAR® light ..... 57  
PrograManager ..... 42  
    auto mode ..... 52  
program caution ..... 34  
programmed recording light .. 57  
programming  
    auto speed ..... 33  
    cancel ..... 30, 35  
    changing settings while ..... 30

## Q

quick program/VCR plus+ button  
    ..... 56  
quick program ..... 30  
quick search ..... 40

## R

rear panel jacks ..... 58  
rec button ..... 55, 56  
record cancel ..... 30  
record light ..... 57  
recording  
    canceling programmed ..... 35  
    canceling one in progress .... 30  
    conventional VCR timer ..... 28  
    current broadcast ..... 21  
    format ..... 24  
    one-touch ..... 22  
    Quick Program ..... 30  
    standby one-touch ..... 23  
    timer ..... 28  
    VCR Plus+® ..... 31  
rec speed button ..... 56  
remote control buttons ..... 55  
    sensor ..... 56  
rental xpress ..... 50  
repeat playback ..... 27, 42  
rew button ..... 55, 56  
rewinding a tape ..... 12, 40  
RF converter setting ..... 49

## S

SAP indicator ..... 57  
SAP broadcast ..... 26  
satellite receiver  
    connecting ..... 7  
    memorizing brand code ..... 15  
    notes about using ..... 35  
    programming to record ..... 28  
search techniques ..... 40  
S-ET mode ..... 24  
S-ET indicator ..... 57  
setting the clock ..... 18  
S-input setting ..... 25  
skipping programs ..... 34  
special effects ..... 38  
SP/EP button ..... 55  
stereo indicator ..... 57  
S-through ..... 25

still adjustment ..... 38  
stop button ..... 55, 56  
S-VHS Set-Up menu ..... 24  
S-VHS indicator ..... 57  
S-video input jack ..... 56, 58

## T

tape function ..... 27  
tape speed lights ..... 57  
tape  
    copying ..... 36, 37  
    loading ..... 11  
    playing ..... 11  
    repeating ..... 27, 42  
television, connecting ..... 5, 6  
    operating with remote ..... 53  
time  
    counter ..... 39  
    display current ..... 47  
    gauge ..... 47  
    remaining ..... 47  
timer recording ..... 28  
timer reset button ..... 35, 58  
tracking ..... 39  
trouble checks ..... 59  
TV POWER button ..... 55  
TV/VCR slide switch ..... 55

## V

VCR  
    light ..... 57  
    operating 2 w/ 1 remote .... 54  
    setting up ..... 13  
VCR POWER button ..... 55  
VCR/TV button ..... 55  
video  
    input, output jacks ..... 56, 58  
    mute ..... 48  
volume button ..... 55







# Warranty

## MITSUBISHI VIDEO CASSETTE RECORDER LIMITED WARRANTY

MITSUBISHI DIGITAL ELECTRONICS AMERICA, INC. (MDEA) warrants to the original purchaser of this video cassette recorder if purchased from an authorized MITSUBISHI Audio/Video Dealer that, should it prove defective by reason of improper workmanship and/or material:

- a. **Parts.** For one year from the date of original purchase at retail, we will repair or replace, at our option, any defective part including the video head without charge for the part. Parts used for replacement are warranted for the remainder of the original warranty period.
- b. **Labor.** For ninety days from the date of original purchase at retail, we will provide the labor for a warranty repair without charge at an authorized MITSUBISHI service center.
- c. **Notice.** To obtain warranty service, you must notify an authorized MITSUBISHI service center of any defect within the applicable warranty time period.

**1 TO OBTAIN WARRANTY SERVICE,** deliver your VCR to the nearest MITSUBISHI service center.

Shipping expenses are your responsibility. The name and address of the nearest service center can be obtained from your MITSUBISHI Dealer, or by writing or calling MDEA at the address and telephone number below. Proof of purchase date from an authorized MITSUBISHI Dealer is required when requesting warranty service. Present your sales receipt or other document which establishes proof and date of purchase. THE RETURN OF THE OWNER REGISTRATION CARD IS NOT A CONDITION OF WARRANTY COVERAGE. However, please detach and return the Owner Registration Card so that we can contact you should a question of safety arise which could affect you.

**2 THIS WARRANTY DOES NOT COVER** damage caused by: modification, alteration, repair or service of this product by anyone other than an authorized MITSUBISHI service center; physical abuse to, or misuse of, the VCR; operation in a manner contrary to the instructions which accompany the VCR; freight damage; or any damage caused by acts of God such as lightning or fluctuation in electrical power. This warranty also excludes all costs arising from installation, adjustment of user controls, external antenna systems, service of products purchased or serviced outside the U.S.A., initial technical adjustments (set-up) and user-required maintenance including head cleaning. Consult the operating instructions enclosed with the product for information regarding user controls.

**3 ANY EXPRESS WARRANTY NOT PROVIDED HEREIN, AND ANY REMEDY WHICH, BUT FOR THIS PROVISION, MIGHT ARISE BY IMPLICATION OR OPERATION OF LAW, IS HEREBY EXCLUDED AND DISCLAIMED. THE IMPLIED WARRANTIES OF MERCHANTABILITY AND OF FITNESS FOR ANY PARTICULAR PURPOSE ARE EXPRESSLY LIMITED TO A TERM OF ONE YEAR.**

**4 UNDER NO CIRCUMSTANCES SHALL MDEA BE LIABLE TO PURCHASER OR ANY OTHER PERSON FOR ANY INCIDENTAL, SPECIAL OR CONSEQUENTIAL DAMAGES, WHETHER ARISING OUT OF BREACH OF WARRANTY, BREACH OF CONTRACT, OR OTHERWISE.**

**5 Some states do not allow limitations on how long an implied warranty lasts, or the exclusion or limitation of incidental, special, or consequential damages, so the above limitations or exclusions may not apply to you.**

**6 This warranty gives you specific legal rights and you may also have other rights which vary from state to state.**

**7 BEFORE REQUESTING SERVICE,** please review the instruction booklet to insure proper installation and correct customer control adjustment. If the problem persists, contact your nearest MITSUBISHI Dealer for name(s) of authorized MITSUBISHI Service Center(s). If you are unable to obtain the information, please call 1-800-332-2119, or write us at the address below.

MITSUBISHI DIGITAL ELECTRONICS AMERICA, INC.  
9351 Jeronimo Road  
Irvine, CA 92618-1904



**RETAIN THIS PORTION FOR YOUR RECORDS**

SERIAL NO. \_\_\_\_\_

CUSTOMER NAME \_\_\_\_\_

STREET ADDRESS \_\_\_\_\_

CITY \_\_\_\_\_ STATE \_\_\_\_\_ ZIP \_\_\_\_\_

PHONE (\_\_\_\_) \_\_\_\_\_ PURCHASE DATE \_\_\_\_ / \_\_\_\_ / \_\_\_\_

MO DAY YR

PLACE OF PURCHASE \_\_\_\_\_

PHONE (\_\_\_\_) \_\_\_\_\_

For your nearest Mitsubishi Authorized Service Center  
call 1-800-332-2119



THE BIG SCREEN COMPANY™

MITSUBISHI DIGITAL ELECTRONICS AMERICA, INC.

9351 Jeronimo Road  
Irvine, CA 92618-1904  
[www.mitsubishi-tv.com](http://www.mitsubishi-tv.com)

© 2000 Mitsubishi Digital Electronics America, Inc.

Printed in Japan  
872C243A0