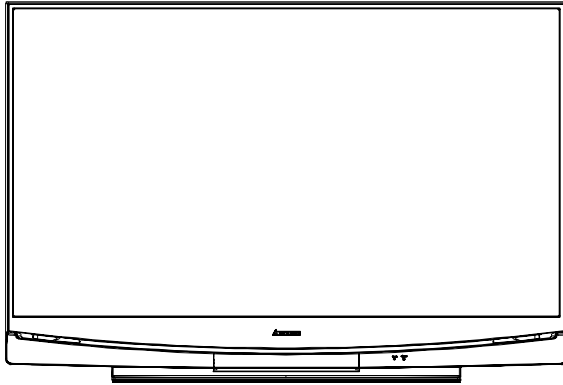

Service Manual

DLP PROJECTION HDTV
V41C, V41 & V41+ CHASSIS

V41C Chassis
WD-60C9
WD-65C9
WD-73C9
V41+ Chassis
WD-65837
WD-73837
WD-82837
V41 Chassis
WD-60737
WD-65737
WD-73737
WD-82737
CAUTION:

Before servicing this chassis, it is important that the service person read the "SAFETY PRECAUTIONS" and "PRODUCT SAFETY NOTICE" contained in this manual.

SPECIFICATIONS

- | | | | |
|-----------------------------|---|-----------------------|---|
| • Power Input | : AC 120V, 60Hz | • Speakers | : Two 5½"x2¼" Oval (8Ω 10W) |
| • Power Usage | : See table on page 5 | • Input Level | : VIDEO IN JACK (RCA Type)
1.0Vp-p 75Ω unbalanced |
| • Light Engine | : DLP™ (1080p)
5 Primary Color System | | : AUDIO IN JACK (RCA Type)
-4.7dBm 43kΩ unbalanced |
| • Light Source | : 180W | • Output Level | : AUDIO OUT JACK (RCA Type)
-4.7dBm 4.7kΩ unbalanced |
| • Channel Range | : Analog Cable - 1~125
Digital Cable - 1~135 | • Digital | : AC-3 Digital Audio Output
(RCA Type) |
| • Antenna Input | : 1 RF 75Ω unbalanced | | : HDMI™ |
| • Tuning | : 1 NTSC/ATSC/QAM | | : IR Blaster Output (V41+ only) |
| • Cabinet Dimensions | : See Table on page 5 | | : USB |
| • Weight | : See table on page 5 | | : PC - use HMDI™\ |
| | | | : Wired IR Input (V41+ only) |

• Design specifications are subject to change without notice.

MITSUBISHI DIGITAL ELECTRONICS AMERICA, INC.

9351 Jeronimo Road, Irvine, CA 92618-1904

Copyright © 2009 Mitsubishi Digital Electronics America, Inc.

All Rights Reserved

CONTENTS

INTRODUCTION	5
Dimensions, weight, power usage, etc.	5
PRODUCT SAFETY NOTICE	5
SAFETY PRECAUTIONS	6
DISASSEMBLY	7
Back Cover Removal	7
Chassis Removal	7
Rear Terminal Cover Removal	8
Power Supply Shield Removal	
PWB-POWER Removal	8
Top Chassis Brackets Removal	9
PWB-MAIN Removal	9
Optical Engine Assembly Components and Connector Locations	10
PWB-BALLAST Removal	10
Optical Engine Assembly Removal	11
Duct Assembly Removal	11
Optical Engine Replacement	13
Color Wheel Replacement	14
Projection Lens Replacement	15
SCREEN REPLACEMENT	16
Screen Replacement 60" 65" 73"	16
Screen Replacement 82"	19
MIRROR REPLACEMENT	22
SPEAKER & PWB-SBL Replacement	23
INITIALIZATION, INITIAL SETTINGS & TROUBLESHOOTING	22
Remote Control	24
Option Menu	25
Reset and Initialization	26
Initial Settings	27
A/V Reset	28
LED Indications & Self Diagnostics	29
Error Codes	30
Error Code Log	30
SERVICE ADJUSTMENTS	31
Equipment & Test Signals	31
Service Mode	31
Horizontal & Vertical Position Adjustment	32
Index Delay Adjustment	32
Manual Geometry Alignment	33
Phase 1 - 16 Point Alignment	33
Phase 2 - 4:3 and 16:9 Alignment	33
Phase 3 - Touch Up Alignment	35
Data Transfer	36
USING LEAD FREE SOLDER	37

- CHIP PARTS REPLACEMENT 38**

- REPLACEMENT PARTS 39**
 - Parts Ordering 39
 - Critical and Warranty Parts Designation 39
 - Parts Tolerance Codes 39

- PARTS QUICK REFERENCE LIST 40**

- SERVICE PARTS LIST 41**

- SCREEN ASSEMBLY PARTS LIST 47**

- MIRROR KITS AND PREPARATION 49**

- CIRCUITRY BLOCK DIAGRAMS 51**
 - Main Power Supply 51
 - DC to DC Supplies 52
 - Power Control 53
 - System Control 54
 - Lamp Control 55
 - Audio/Video Signal Path 56

- SCHEMATIC DIAGRAMS**

Digital Light Processing®, Digital Micro Mirror Device and DLP® are Trademarks of Texas Instruments.
HDMI, the HDMI logo and High-Definition Multimedia Interface are trademarks or registered trademarks of HDMI Licensing, LLC..

INTRODUCTION

This service manual provides service instructions for the V41C, V41 and V41+ chassis types. The specific models for each chassis type, dimensions and weight are listed below. Service personnel should read this manual thoroughly before servicing these chassis.

MODEL	CHASSIS	HEIGHT	WIDTH	DEPTH	WEIGHT	POWER USAGE
WD-60C9	V41C	36.7"	53.9"	14.4"	64.9 lbs	260W
WD-60737	V41	36.7"	53.9"	14.4"	64.9 lbs	260W
WD-65C9	V41C	39.5"	58.2"	15.3"	72.2 lbs	260W
WD-65737	V41	39.5"	58.2"	15.3"	72.2 lbs	260W
WD-65837	V41+	39.5"	58.2"	15.3"	72.2 lbs	260W
WD-73C9	V41C	43.6"	65.2"	17.5"	92.84 lbs	260W
WD-73737	V41	43.6"	65.2"	17.5"	92.84 lbs	260W
WD-73837	V41+	43.6"	65.2"	17.5"	92.84 lbs	270W
WD-82737	V41	48.5"	73.2"	22.7"	139.7 lbs	270W
WD-82837	V41+	48.5"	73.2"	22.7"	139.7 lbs	270W

This service manual includes:

1. Assembly and disassembly instructions for cabinet and chassis components.
2. Servicing of the Lenticular Screen and Fresnel Lens.
3. Servicing printed circuit boards (PCBs).
4. Electrical and Mechanical adjustments.
6. Chip parts replacement procedures.
7. Circuit block diagrams.

The parts list section of this service manual includes:

1. Cabinet and screen parts.
2. Electrical parts.

Schematic and block diagrams of the above listed models are included in this service manual for better understanding of the circuitry.

PRODUCT SAFETY NOTICE

Many electrical and mechanical parts in television receivers have special safety related characteristics. These characteristics are often not evident from visual inspection nor can the protection afforded by them necessarily be obtained by using replacement components rated for higher voltage, wattage, etc.

Replacement parts which have special safety characteristics are identified in this service manual.

Electrical components having such features are identified by shading on the schematic diagram and parts list of this service manual. **The replacement for any safety part should be identical in value and characteristics.**



Solder

The PWBs used in this chassis are constructed using Lead-Free Solder. **When servicing use only recommended Lead-Free Solder. Refer to the section "Using Lead Free Solder."**

SAFETY PRECAUTIONS

NOTICE: Observe all cautions and safety related notes located inside the receiver cabinet and on the receiver chassis.

WARNING:

1. Operation of this receiver outside the cabinet or with the cover removed presents a shock hazard from the receiver's power supplies. Work on the receiver should not be attempted by anyone who is not thoroughly familiar with the precautions necessary when working on high voltage equipment.
2. When service is required, observe the original lead dress. Where a short-circuit has occurred, replace those components that indicate evidence of overheating.

SAFETY PRECAUTION

To protect your eyes, do not look directly into the lamp, or light coming directly from the lamp, lens or mirror.

Leakage current check

Before returning the receiver to the customer, it is recommended that leakage current be measured according to the following methods.

1. Cold Check

With the alternating current (AC) plug removed from the AC source, place a jumper across the two AC plug prongs. Connect one lead of an ohm meter to the AC plug and touch the other lead to each exposed metal part (i.e. antennas, handle bracket, metal cabinet, screw heads, metal overlay, control shafts, etc.), particularly any exposed metal part that has a return path to the chassis. The resistance of the exposed metal parts having a return path to the chassis **should be a minimum of 1Meg Ohm**. Any resistance below this value indicates an abnormal condition and requires corrective action.

2. Hot Check ...Use the circuit shown below to perform the hot check test.

1. Keep switch S1 open and connect the receiver to the measuring circuit. Immediately after connection, and with the switching devices of the receiver in their operating positions, measure the leakage current for both positions of switch S2.
2. Close switch S1, energizing the receiver. Immediately after closing switch S1, and with the switching devices of the receiver in their operating positions, measure the leakage current for both positions of switch S2. Repeat the current measurements of items 1 and 2 after the receiver has reached thermal stabilization. **The leakage current must not exceed 0.5 milliampere (mA).**

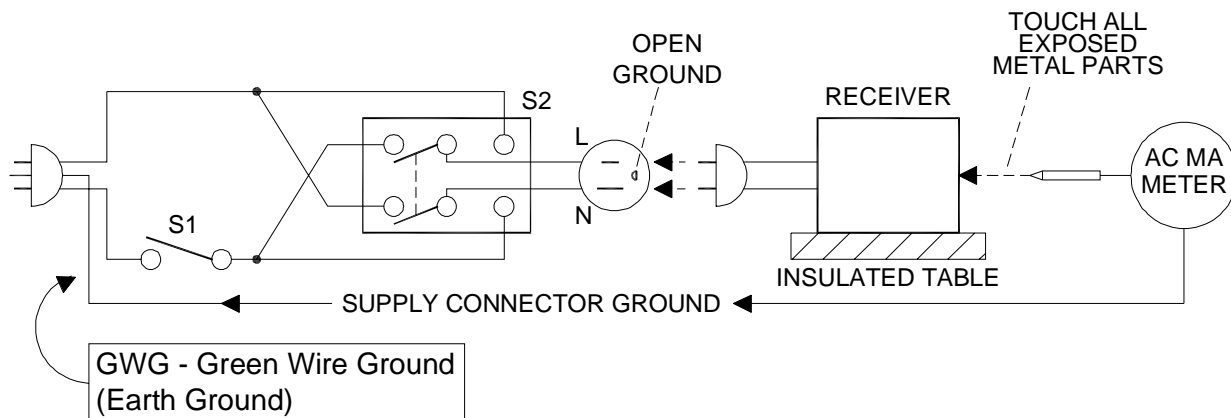

DISASSEMBLY

BACK COVER REMOVAL

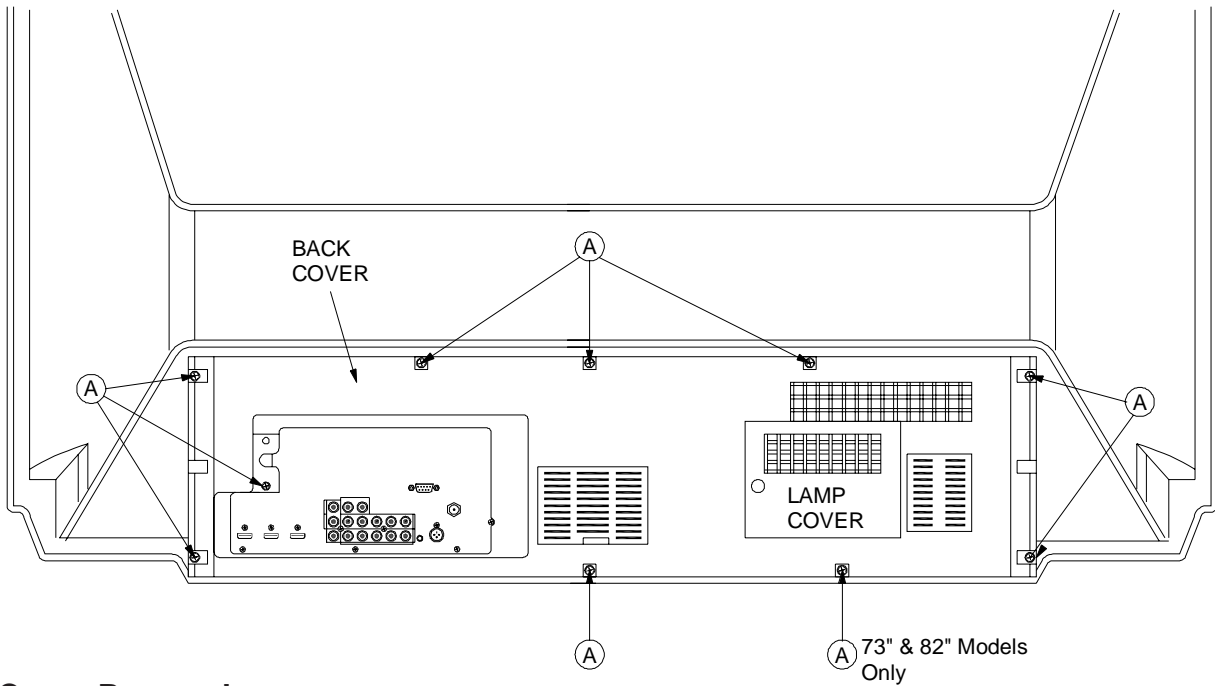

Back Cover Removal

- 1) Remove screws (A) from the back cover.
- 2) Remove the back cover from the TV.

CHASSIS REMOVAL & DISASSEMBLY

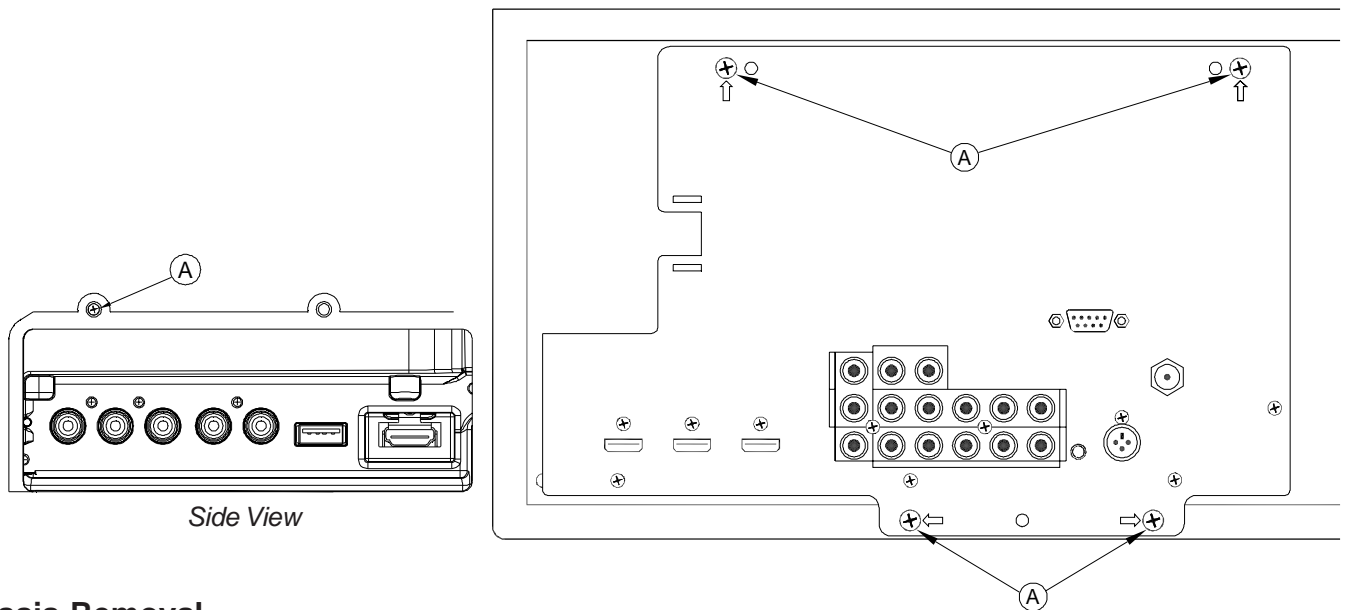

Chassis Removal

- 1) Remove five screws (A), one side, four rear.
- 2) Disconnect all cables connecting to the chassis.
- 3) Slide the chassis out of the cabinet.

CHASSIS REMOVAL & DISASSEMBLY (Continued)

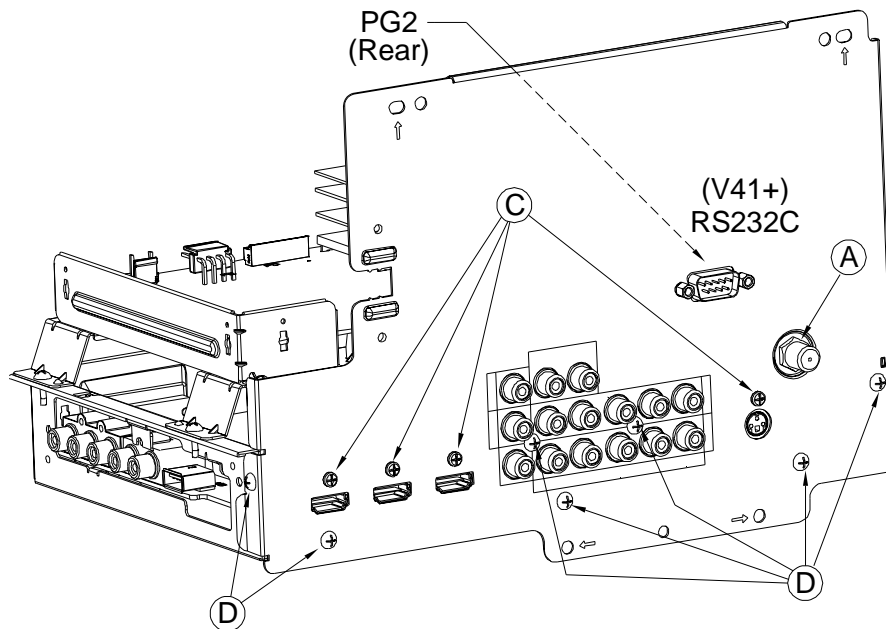

Rear Terminal Cover Removal

- 1) Remove nut (A) from the ANT input.
- 2) Disconnect connector PG2 from the rear of the RS232C assembly (V41+ only).
- 3) Remove screws (C) and (D).
- 4) Remove the Terminal Cover from the chassis.

Power Supply Shield Removal

- 1) Remove screw (A).
- 2) Remove the Power Supply Shield from the chassis.

PWB-POWER Removal

- 1) Remove screws (B).
- 2) Disconnect all cables from the PWB-POWER.
- 3) Lift the PWB-POWER from the chassis.

PWB-POWER Installation

NOTE: The PWB-POWER should be re-installed so the Heat Sink is opposite the Power Supply Shield.

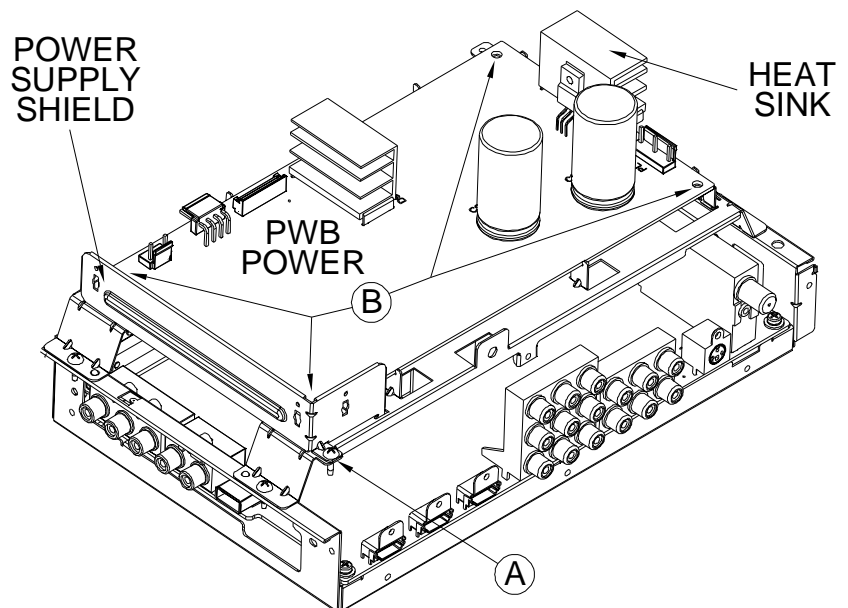

CHASSIS REMOVAL & DISASSEMBLY (Continued)

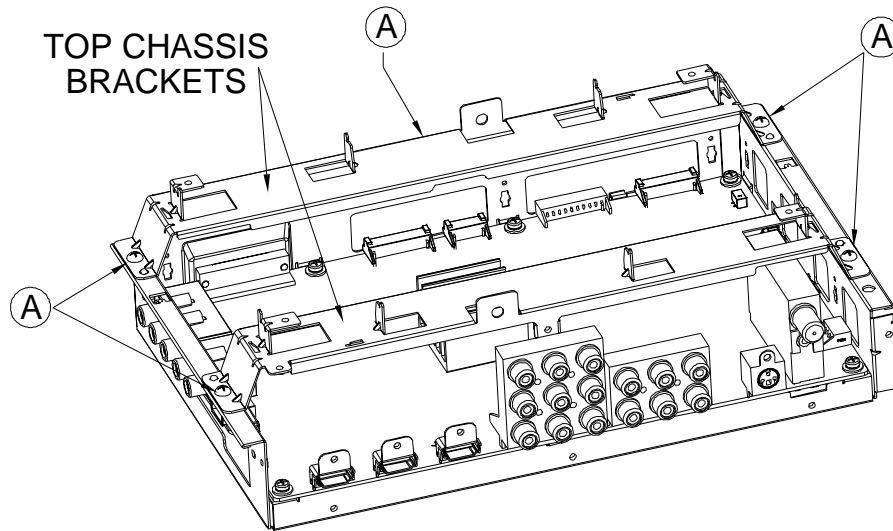

Top Chassis Brackets Removal

NOTE: Removal of the Power Supply Shield and PWB-POWER is not required to remove the Top Chassis Brackets.

- 1) Remove screws (A).
- 2) Disconnect all cables from the PWB-POWER.
- 3) Lift the Top Chassis Brackets from the chassis.

PWB-MAIN Removal

- 1) Disconnect all cables to PWB-MAIN.
- 2) Remove screws (A) from the DVI connector.
- 3) Remove screws (B) from the Side Terminals.
- 4) Remove screw (C) from the Side HDMI connector (V41+ only).
- 5) Remove screws (D).
- 6) Lift the PWB-MAIN out of the chassis.

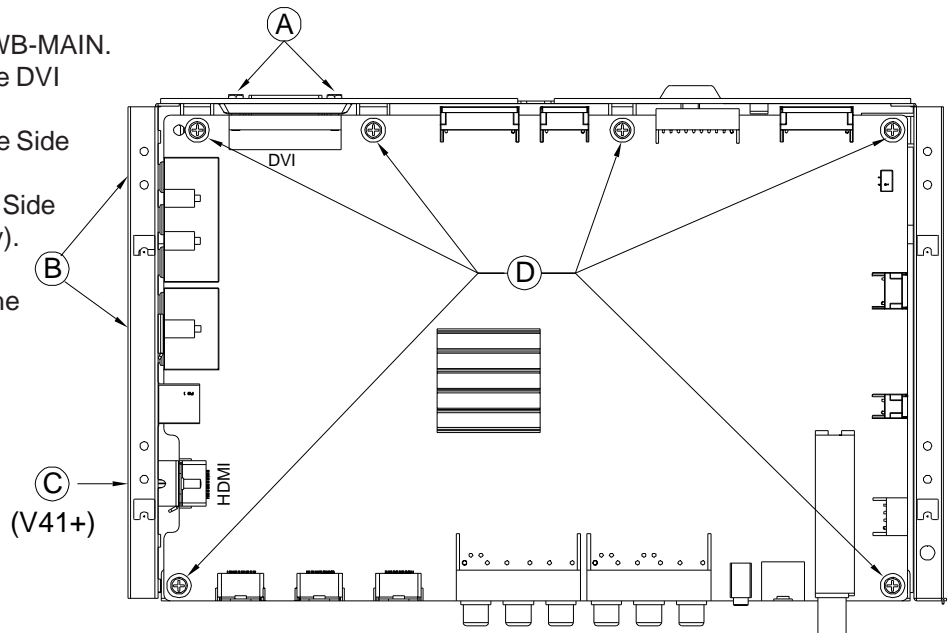

PWB-MAIN Installation

- 1) Install screws (A) (B) and (C) first.
- 2) Then install screws (D).
- 3) Perform "Restore Engine Data From Backup" (See Data Transfer in Service Adjustments section).
- 4) Perform "Restore Geometry Data From Backup" (See Data Transfer in Service Adjustments section).

OPTICAL ENGINE ASSEMBLY

OPTICAL ENGINE ASSEMBLY - COMPONENT AND CONNECTOR LOCATIONS (Rear View)

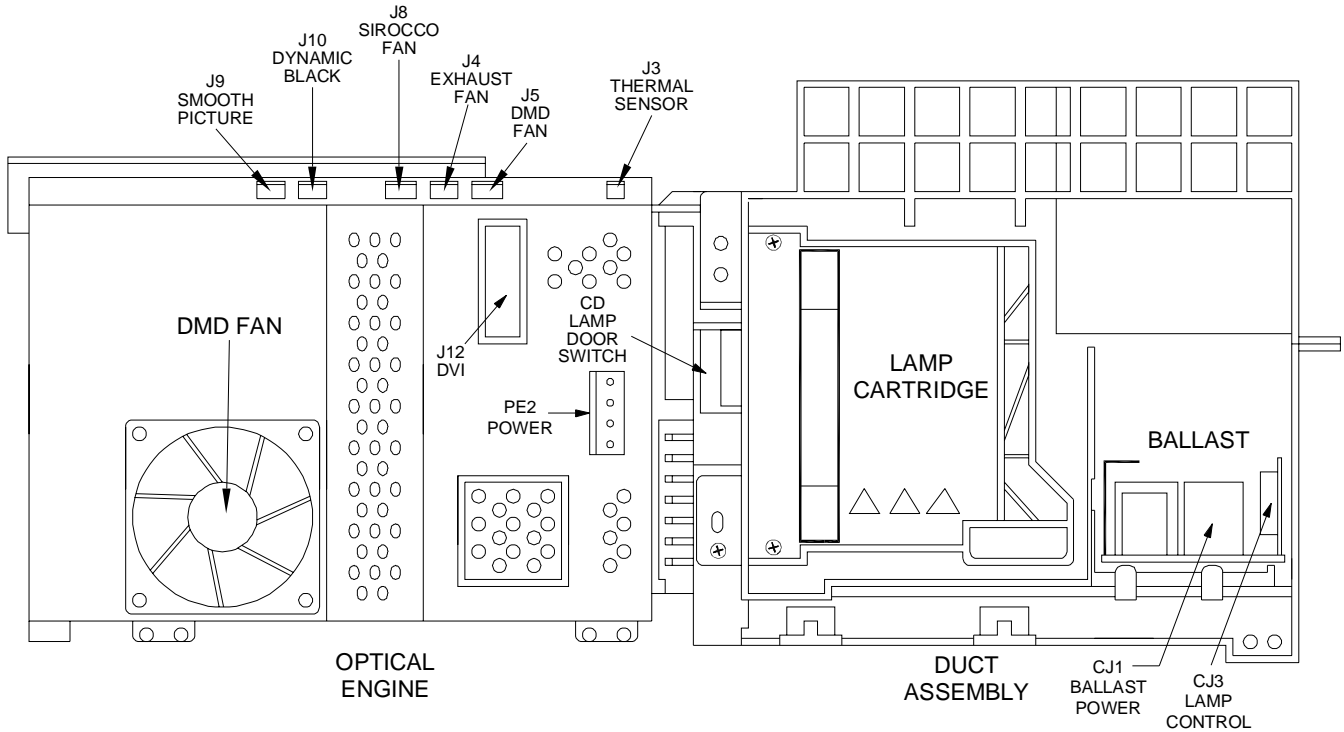

PWB-BALLAST REPLACEMENT

Note: To remove the PWB-Ballast, it is not necessary to remove the Engine or Lamp Cartridge.

- 1) Release the Latch to lift the PWB-BALLAST from the mounting bracket.
- 2) Slide the PWB-Ballast out of the Engine Assembly.
- 3) Disconnect connectors CJ1, CJ3 and CJ4, the HV Lamp connector.
- 4) To reinstall, first connect the connectors. Then slide the PWB under the Retaining Hooks. Then press the rear edge of the PWB down onto the guide pins to engage the latch.

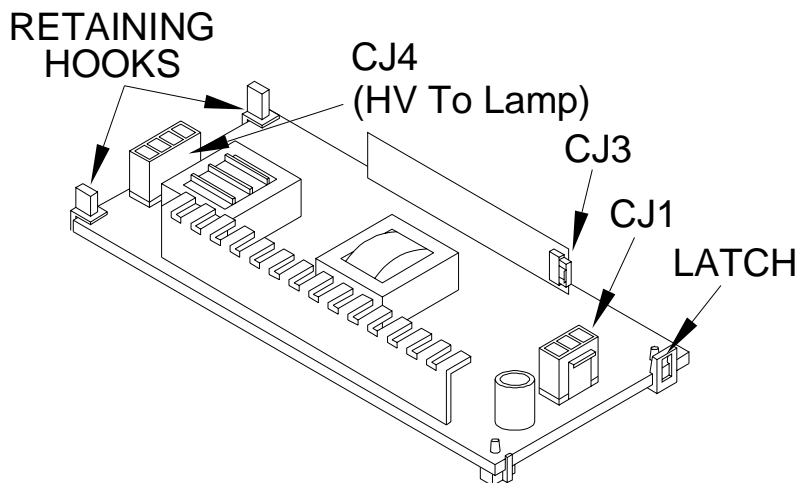

OPTICAL ENGINE REPLACEMENT

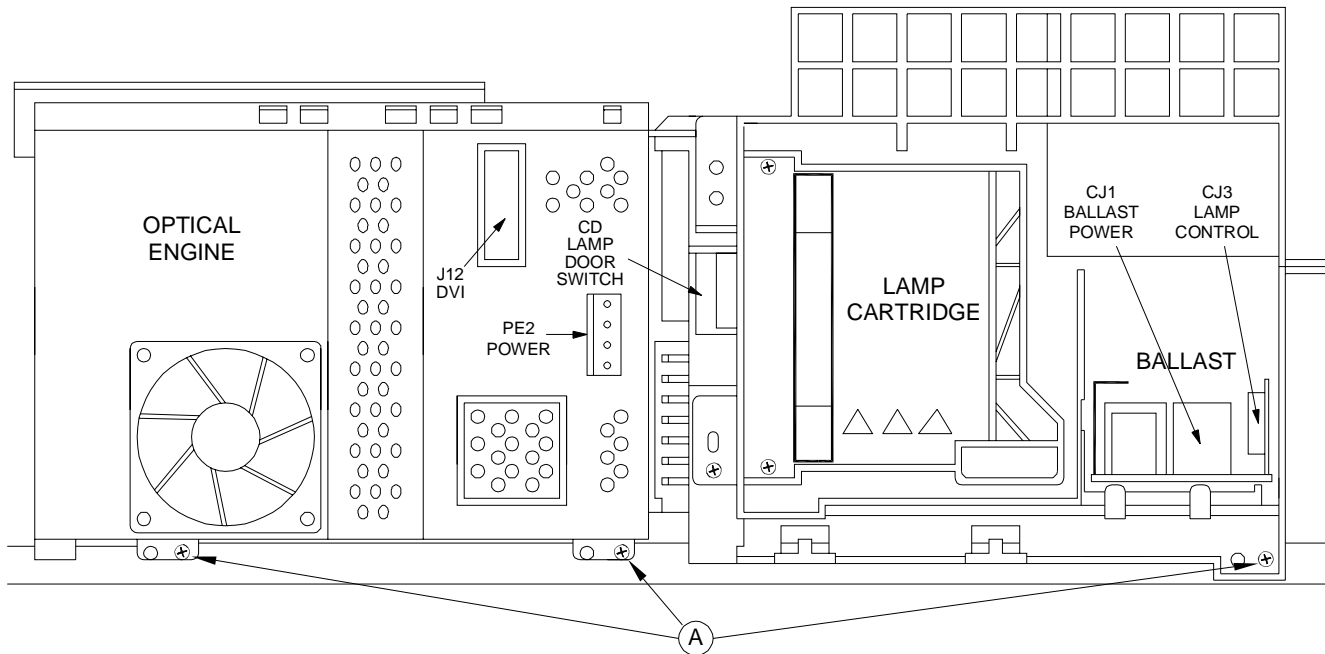

OPTICAL ENGINE ASSEMBLY REMOVAL

- 1) Remove 3 screws (A) from the Optical Engine.
- 2) Disconnect all cables to the Optical Engine Assembly.
- 3) Slide the Optical Engine assembly out of the cabinet.

DUCT ASSEMBLY REMOVAL

Upper Duct Assembly Removal Procedure

- 1) Loosen two screws (A) and remove the Lamp Cartridge.
- 2) Disconnect the Exhaust and Sirocco Fan Connectors (J4 and J8) from the back of the Engine and loosen the wiring harnesses from the looms, refer to previous page for connector locations.
- 3) Remove screw (B) from the top of the upper duct and release the latches shown in *Figure 2*.
- 4) Remove the Upper Duct assembly from the Optical Engine.

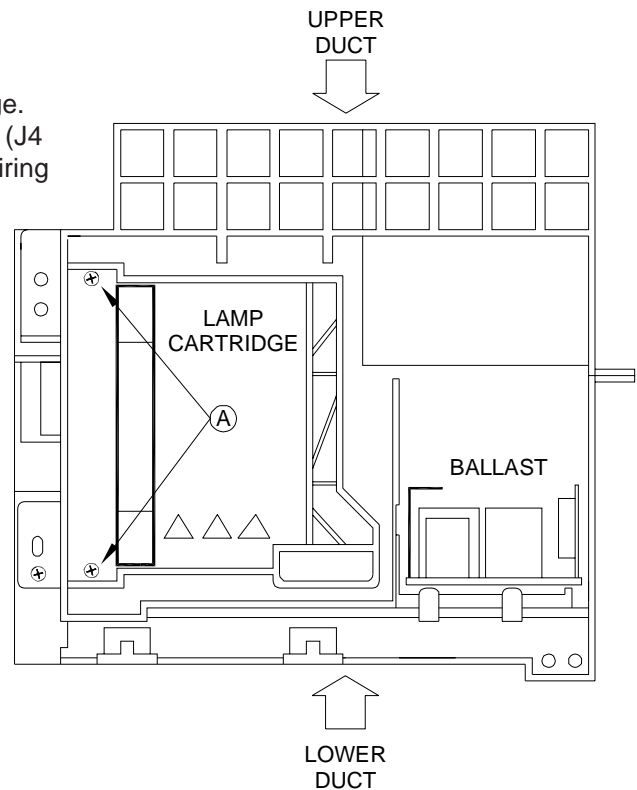

Figure 1: Duct Assembly (Rear View)

OPTICAL ENGINE REPLACEMENT (Continued)

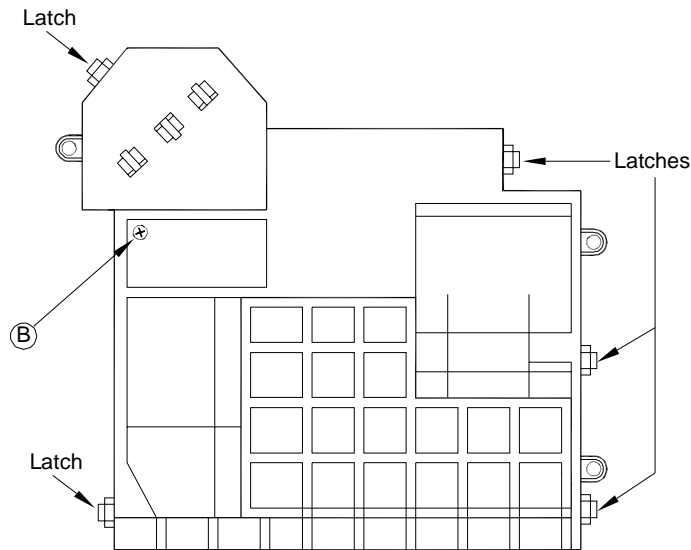

Figure 2: Duct Assembly (Top View)

DUCT INTERIOR COMPONENTS

- 1) Figure 3 shows the Duct Interior Components.
- 2) The Upper Duct must be removed to replace the Lamp Door Switch PWB, Sirocco Fan, Exhaust Fan and Thermal Sensor (1 screw).
- 3) When replacing the Engine, transfer the Duct Interior Components from old Engine to the new Engine.

Note: There are three Exhaust Fan Holders, one on the top and two on the bottom of the Exhaust Fan.

Note: The Exhaust Fan must be installed so the Label is facing inside the Duct.

Note: The Sirocco Fan must be installed so the Label is facing upwith the Flanges aligned onto the Guide Pins.

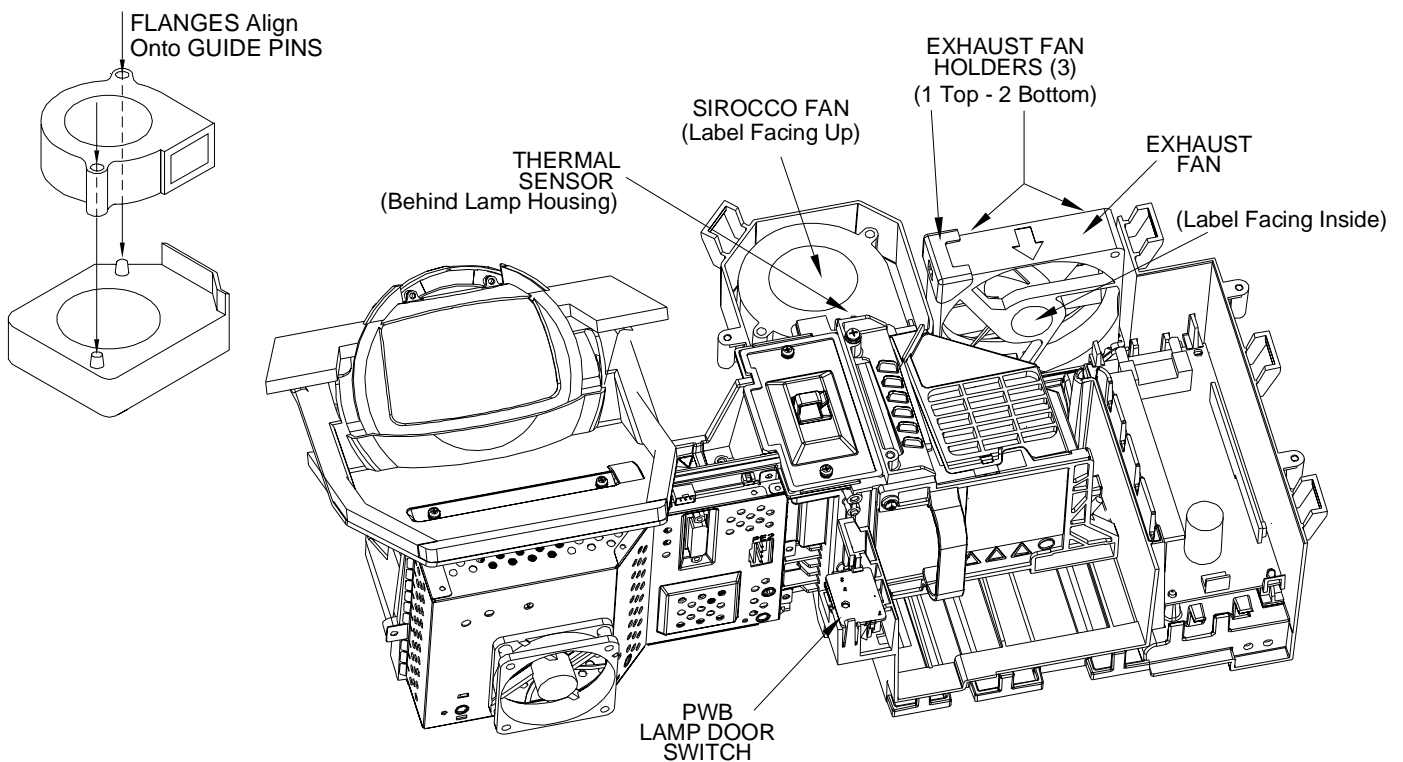

Figure 3: Lower Duct (Top View)

OPTICAL ENGINE REPLACEMENT (Continued)

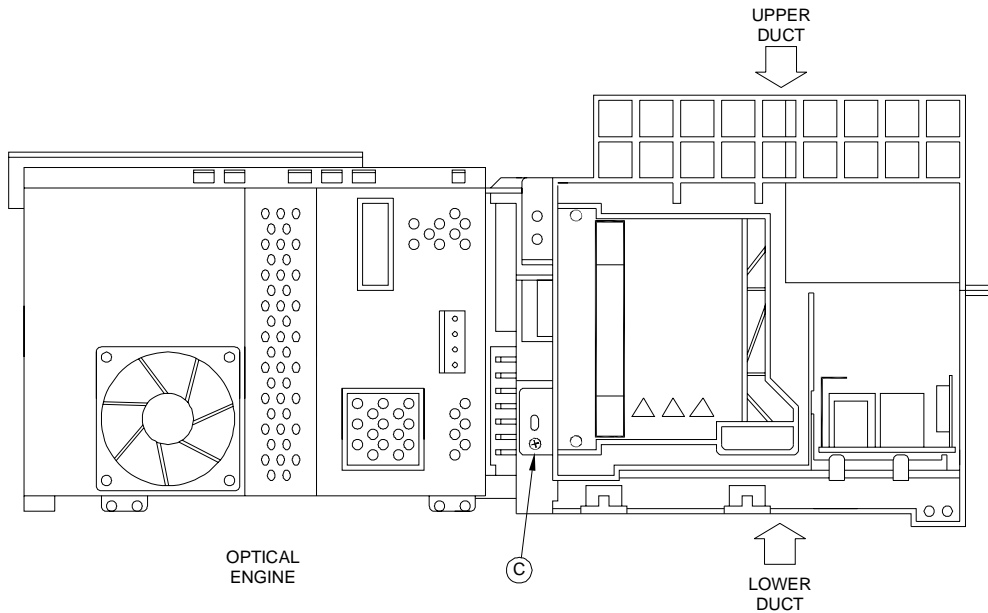

Figure 4: Lower Duct Rear Mounting Screw

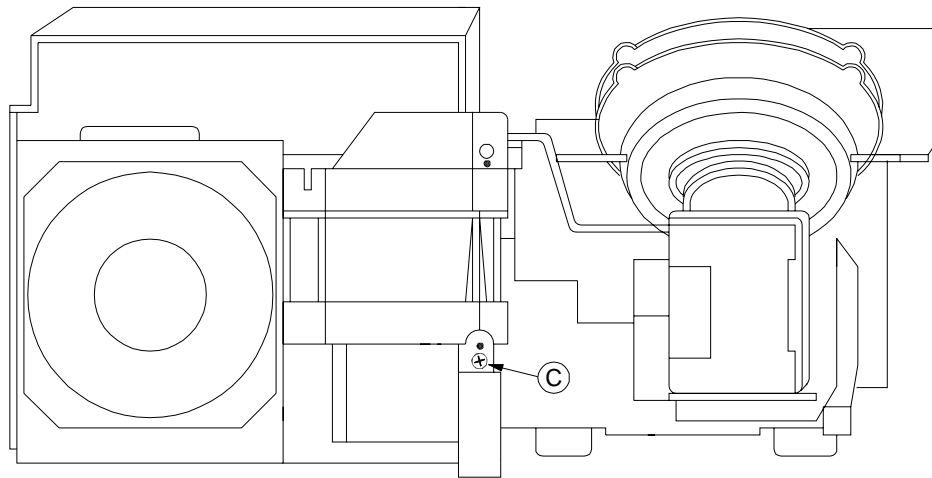

Figure 5: Lower Duct Front Mounting Screw

LOWER DUCT REMOVAL

- 1) Remove Upper Duct, Fans, Fan Holders, Thermal Sensor and Lamp Cartridge. See previous page.
- 2) Remove the 2 screws (C) one in front and one in the rear of the lower duct, refer to *Figures 4 and 5*.
- 3) Carefully remove the lower duct from the Engine.

ENGINE Replacement (Reverse the Removal Procedure)

- 1) Install Duct Assembly on the new Engine.
- 2) Remove the Protective Lens Cover from the face of the Lens and place it on the old Engine.
- 3) Install the Engine Assembly in the cabinet.
- 4) After a new Engine is installed, perform the "Restore Index Delay" and "Save Engine and Geometry Setting to Backup" procedures as described in the Data Transfer section of the Service Adjustments.
- 5) If needed, perform the Horizontal and Vertical Centering Adjustment and Manual Geometry Alignment described in Service Adjustments.

COLOR WHEEL REPLACEMENT

SYMPTOMS

- Noise (Bad Motor Bearing)
- Solarized Picture NOTE: Before replacing the Color Wheel, check the Index Delay Adjustment.

COLOR WHEEL REPLACEMENT PROCEDURE

CAUTION: This procedure should be performed in a dust free environment.

Any dust entering into the color wheel chamber can cause abnormalities in the picture.

- 1) Remove Engine Assembly and cover the projection lens to protect it from scratches.
- 2) Remove the TOP DUCT.
- 3) Remove the 2 screws (A) shown in *Figure 1*.
- 4) Disconnect the 2 connectors J6 & J7 shown in *Figure 1*.
- 5) Lift the top cover off of the color wheel chamber.

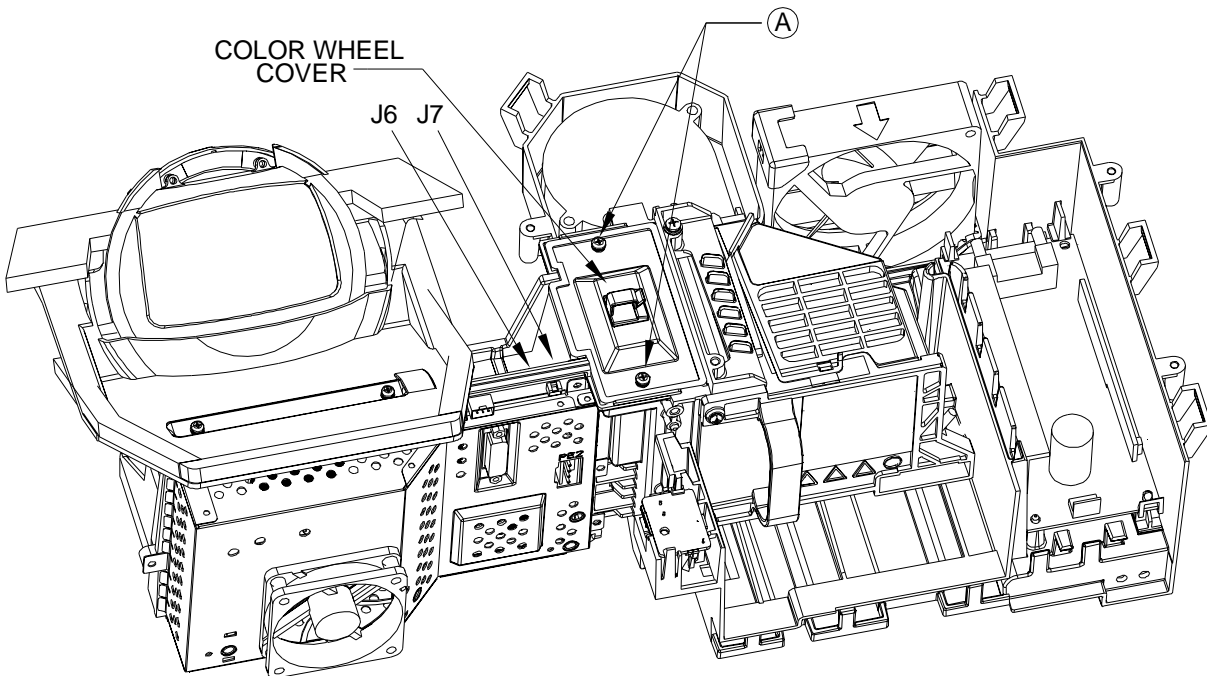

Figure 1: Color Wheel Cover and Connectors

- 6) Remove 3 screws (B) shown in *Figure 2*.
 - 7) Use the Handle to lift the Color Wheel from the chamber.
 - 8) For installation, reverse the procedure above.
- CAUTION: Use care to prevent scratching the Color Wheel.
NOTE: Do not twist the ribbon cable to J6 (the shiny silver contacts must be facing up).
- 9) After re-assembly, perform the Index Delay Adjustment described in the Service Adjustments section.

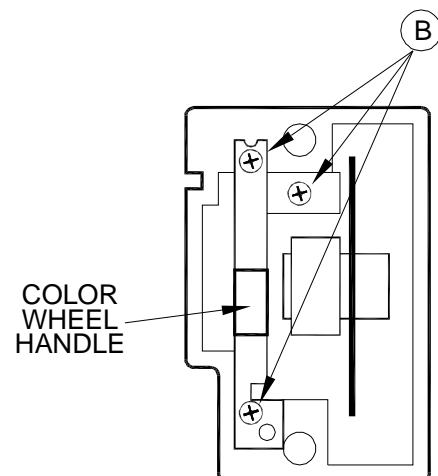

Figure 2: Color Wheel

PROJECTION LENS REPLACEMENT

PROJECTION LENS REPLACEMENT PROCEDURE

CAUTION: Any dust or fingerprints in the optics can cause abnormalities in the picture.
This procedure should be performed in a dust free environment.
Wear lint free cotton or rubber gloves while performing this procedure.

- 1) Remove Engine Assembly.
- 2) Remove screws (A) and rotate the Lens Collar off the Lens in the direction indicated while carefully releasing the foam adhesive from the Lens

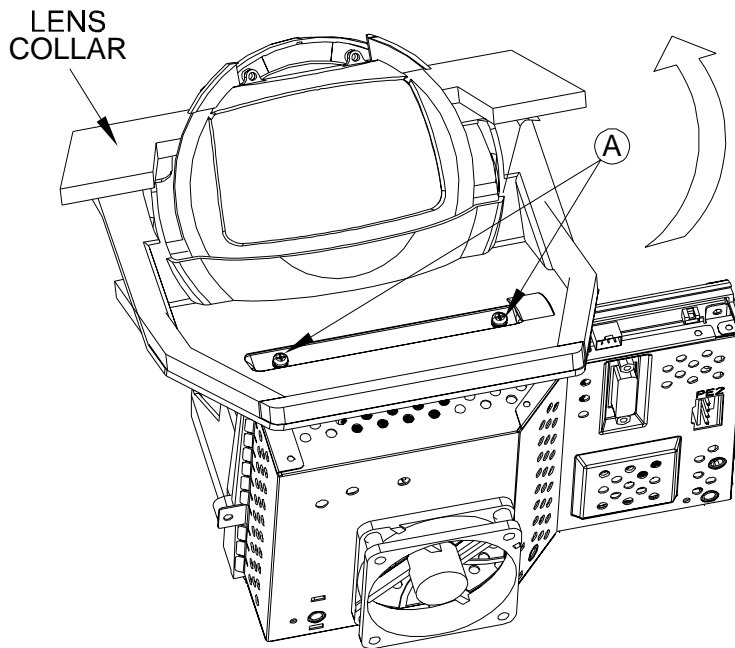

- 3) Remove screws (B) from the Lens Mask and slide the mask off in the direction indicated.
- 4) Lift out the Projection Lens.
- 5) Install the replacement lens so the key is oriented towards the top as shown. For reassembly, reverse the disassembly procedure. Use thread locker to secure screws (B).

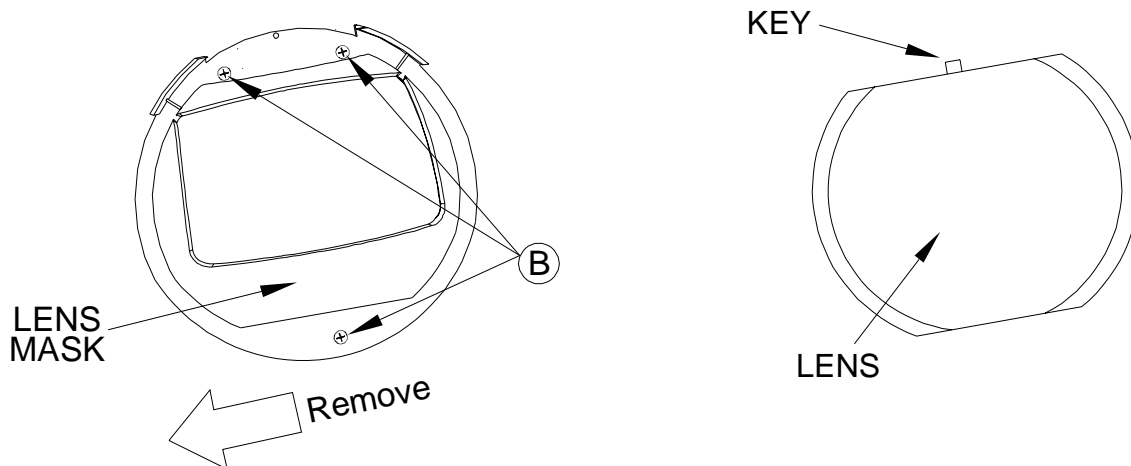

SCREEN REPLACEMENT 60", 65" & 73" Models

Screen Assembly Removal and Replacement

- 1) Open the front control panel door. (V41+ Only) Pull away Speaker Covers followed by Center Escutcheon.
- 2) Remove three screws (A) (two screws WD-73837).
- 3) Remove screws (B) around the rear edge of the screen bezel.
NOTE: Leave one screw secure at the top. Then support the assembly to prevent it from falling while removing the remaining screw.
- 4) During re-assembly replace screws in their original locations.

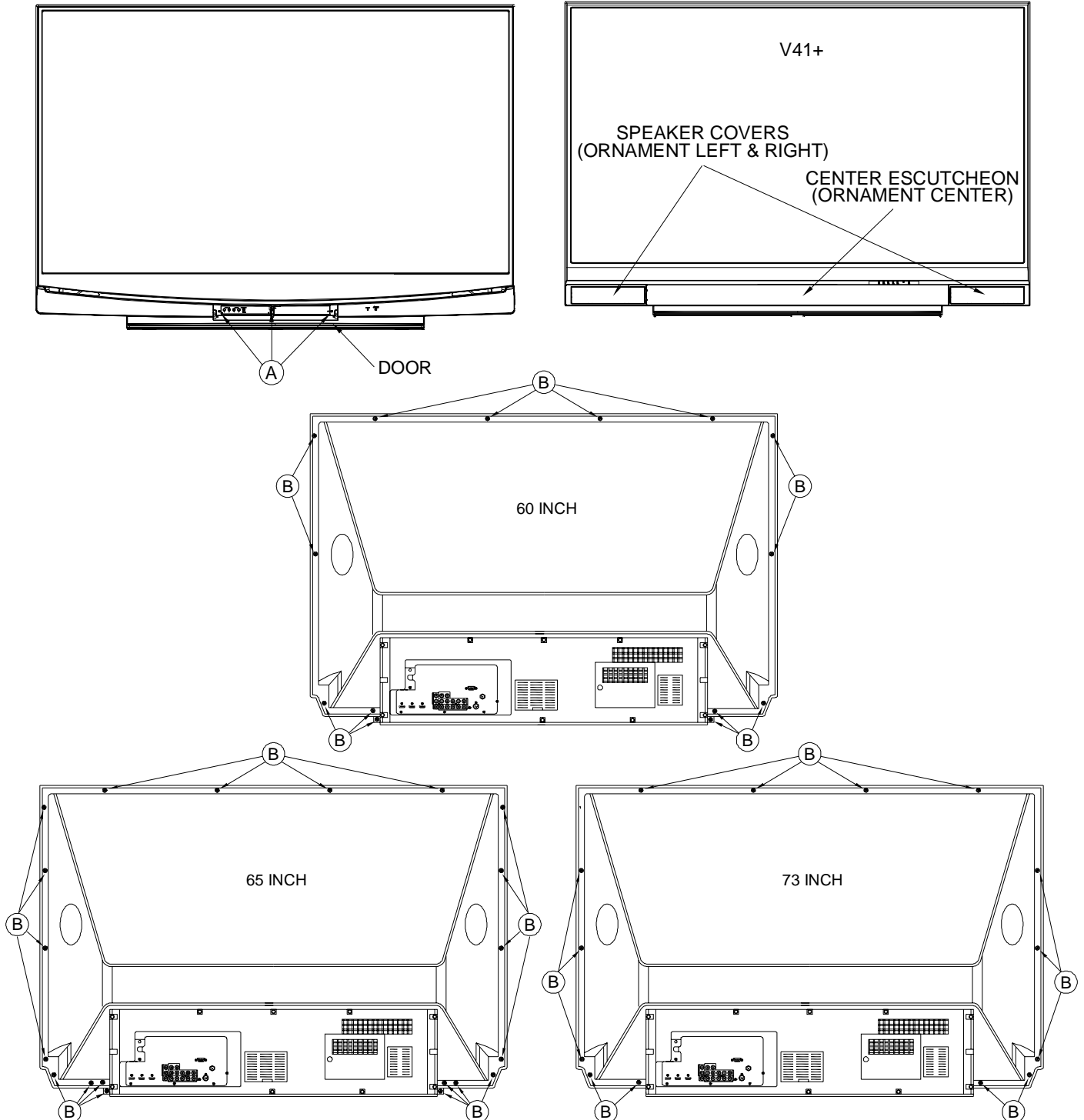

Screen Removal From the Bezel-Front

- 1) Remove screws (A) and remove the top, bottom and side rails.
- 2) Lift the Fresnel Lens and Lenticular screen from the Bezel-Front.
- 3) During re-assembly replace screws in their original locations.

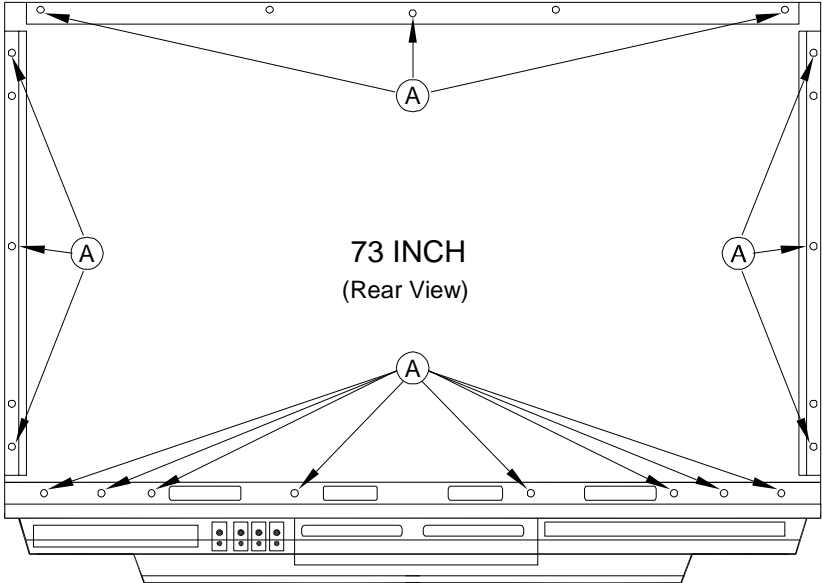
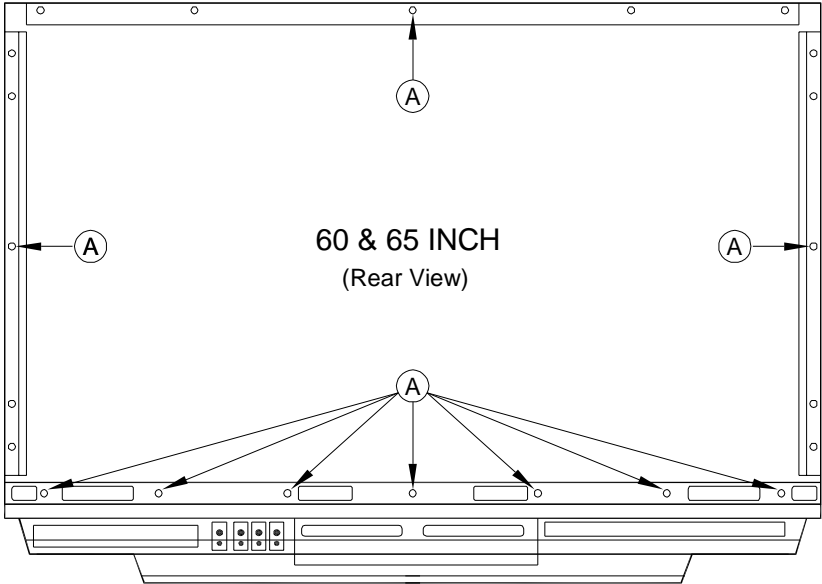

SCREEN REPLACEMENT 60", 65" & 73" Models (continued)

CAUTION: Wear gloves when handling the Lenticular Screen and Fresnel Lens.
This prevents cuts and finger prints. **Do not place Fresnel Lens in the sun.**
This may cause fire and heat related injuries.

Lenticular Screen and Fresnel Lens Removal

- 1) After removing the top, bottom and side HOLDER-SCREEN rails and their cushions from the Bezel, lift the screens as a single unit from the frame.
- 2) Separate the Lenticular Screen and Fresnel Lens.
Note: When separating the Lenticular Screen from the Fresnel Lens, use caution while prying the Screen and Lens apart. Use a slot type screw driver, and remove the pressure sensitive double sided tape.

Lenticular Screen and Fresnel Lens Replacement

- 1) Apply LENS-TAPE along the rear top edge of the Lenticular Screen.
- 2) Place the Fresnel Lens on top of the Lenticular Screen, and apply pressure along the top edge.
- 3) Place the screens in the screen frame and reinstall the cushions, top, bottom and side rails.
NOTE: The Lenticular Screen label must face the front and the Fresnel Lens label face the rear.
- 4) Reverse the Screen Removal Procedure and insert the screens in the Bezel.

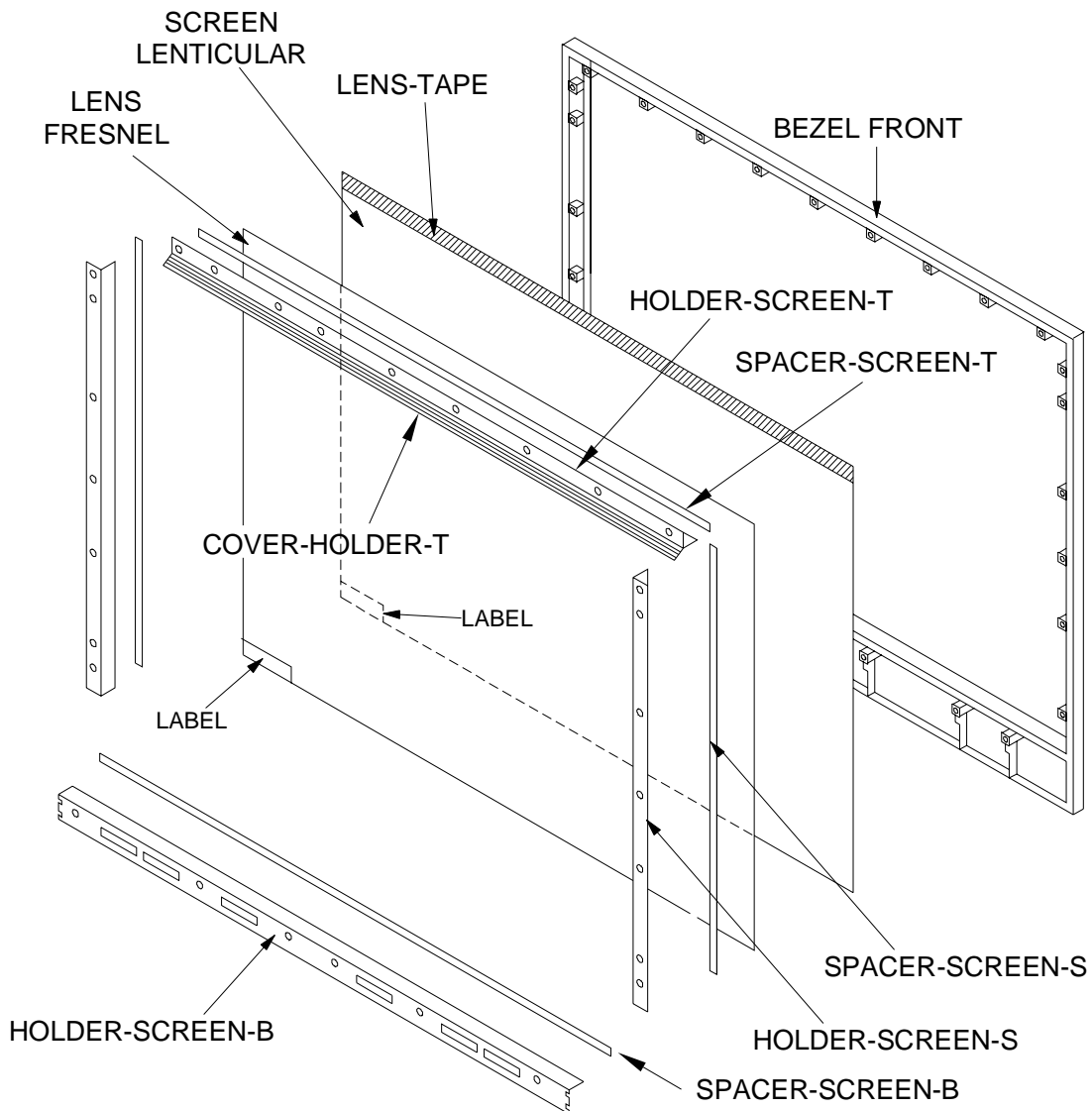

SCREEN REPLACEMENT 82" Models

Front Cover and Pedestal Removal

- 1) Remove screws (A) around the bottom rear edge.
- 2) Open the front control panel door and remove screws (B).
- 3) Lift the Pedestal and Front Cover away from the front.

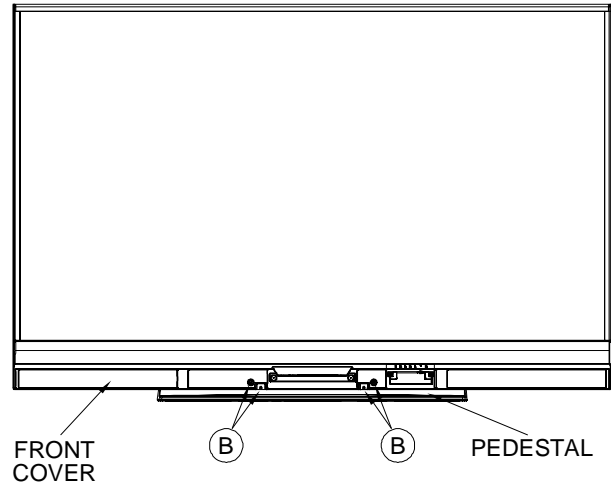
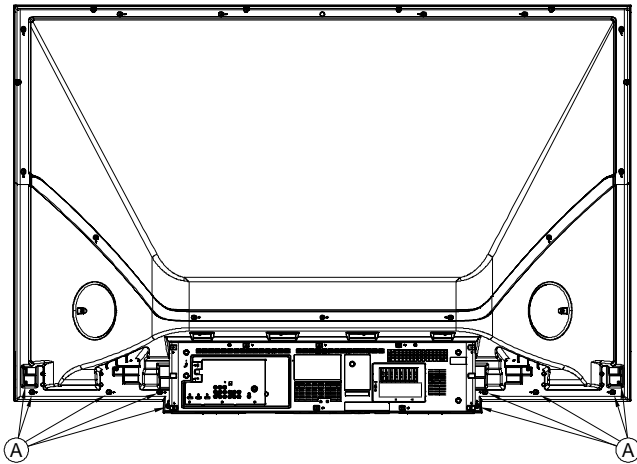

Screen Assembly Removal

- 1) Remove screws (C) from the bottom front of the screen assembly..
 - 2) Remove screws (D) from the top rear edge of the screen bezel.
- NOTE: Leave one screw secure at the top. Then support the assembly to prevent it from falling while removing the remaining screw.

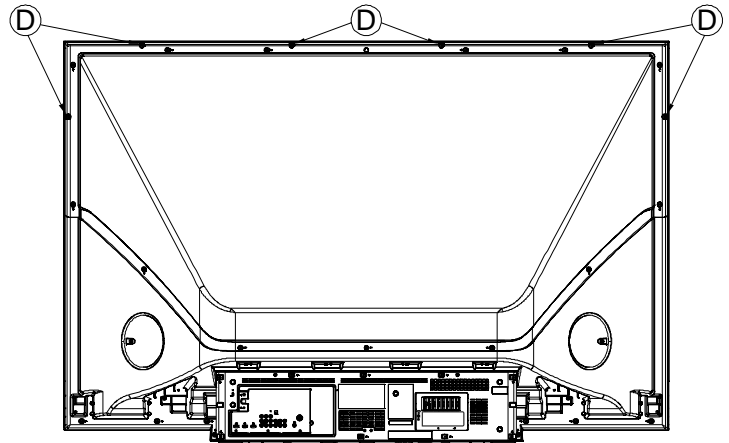
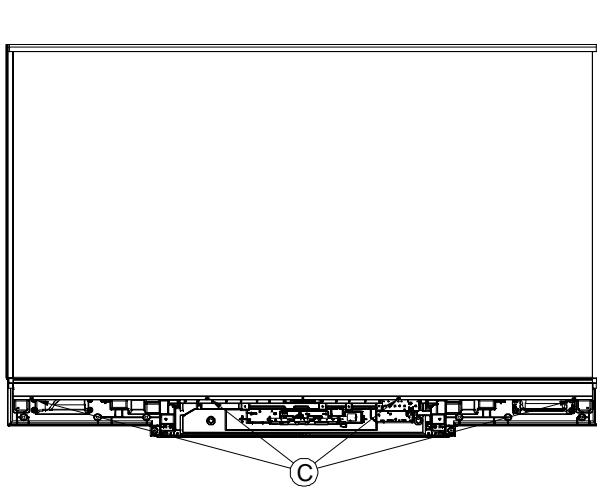

SCREEN REPLACEMENT 82" Models (continued)

CAUTION: Wear gloves when handling the Lenticular Screen and Fresnel Lens.
This prevents cuts and finger prints. **Do not place Fresnel Lens in the sun.**
This may cause fire and heat related injuries.

Lenticular Screen and Fresnel Lens Removal

- 1) Remove four screws (A) in all four corners of the Screen Bezel.
- 2) Remove the Screen Bezel components from the Screen/Lens Assembly.

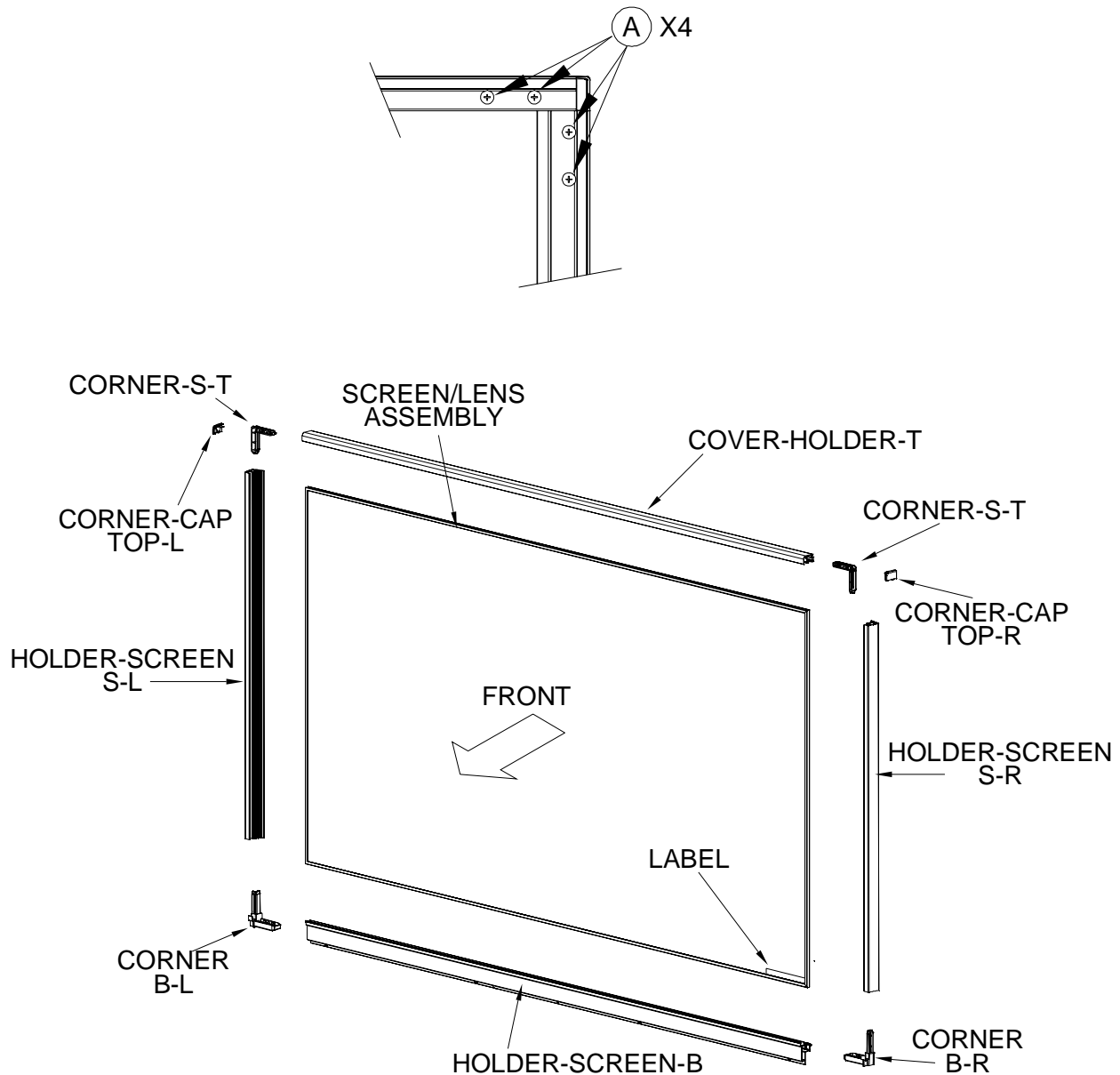

SCREEN REPLACEMENT 82" Models (continued)

Lenticular Screen and Fresnel Lens Disassembly

- 1) Remove the HOLDER-SCREEN from the top, bottom and sides.
- 2) Separate the Lenticular Screen and Fresnel Lens.

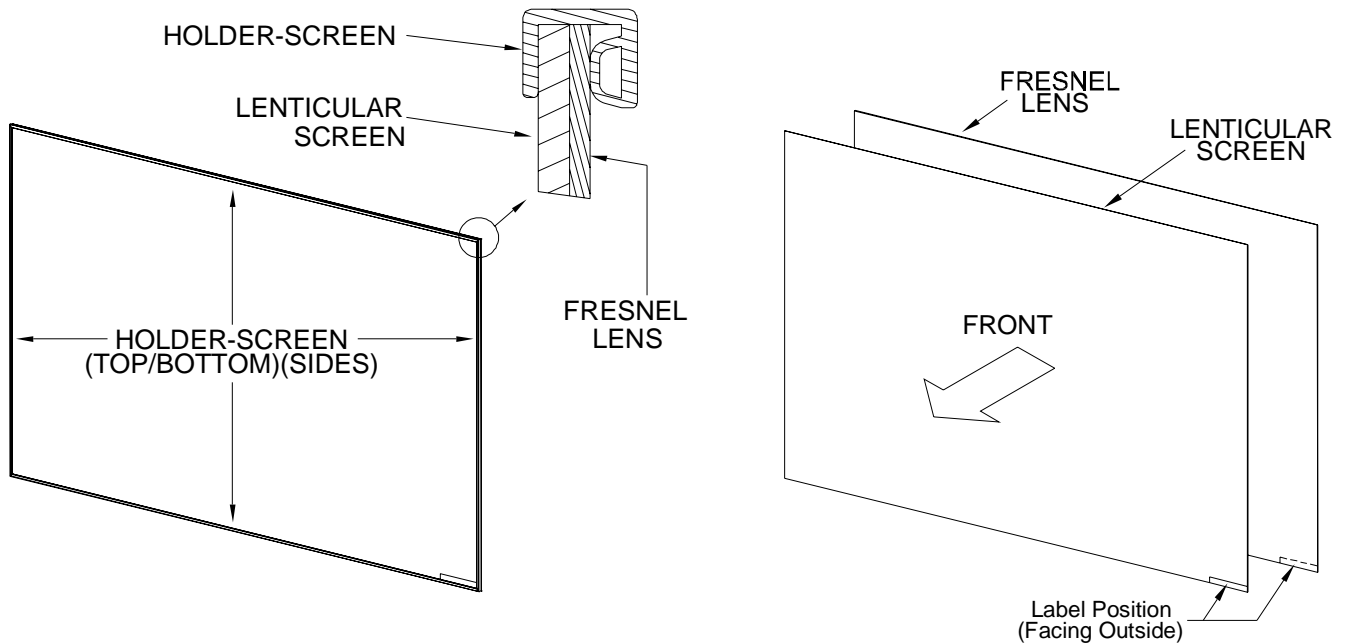

Lenticular Screen and Fresnel Lens Replacement

- 1) Place the Fresnel Lens on top of the Lenticular Screen with the labels facing outside as shown.
- 2) Install the HOLDER-SCREEN, top, bottom and sides as shown above.
- 3) Reverse the disassembly procedure to reassemble and install the screen frame assembly.

NOTE: The Lenticular Screen must face the front and the Fresnel Lens must face the rear.

MIRROR REPLACEMENT

MIRROR REPLACEMENT - 60", 65" & 73" Models

- 1) To access the Mirror for replacement, remove the Screen Assembly (See Screen Assembly Removal).
- 2) The Mirror slides down into the Left, Right and Bottom Brackets inside the cabinet.
- 3) For 73" models, a Top Bracket is installed.
- 3) See the Mirror Parts section for instructions on preparing a replacement mirror.

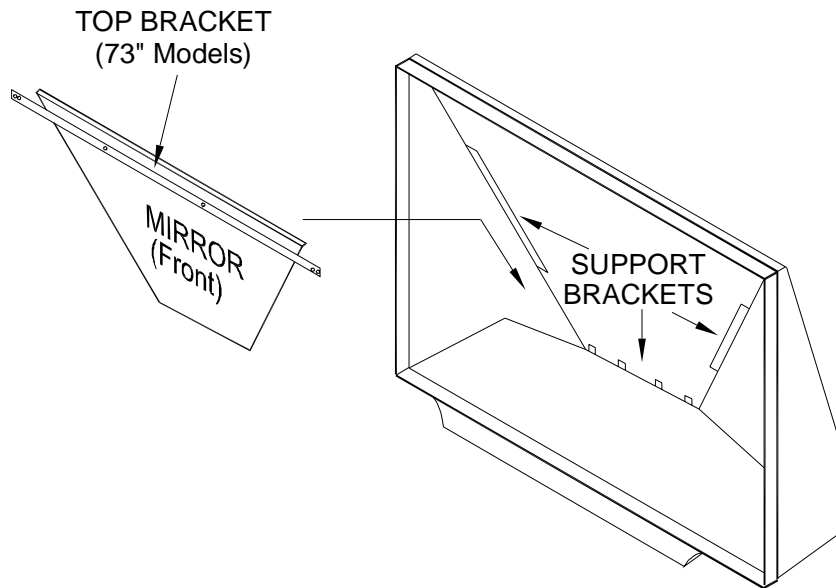

MIRROR REPLACEMENT - 82" Models

- 1) To access the Mirror for replacement, remove screws (A) and lift away the Mirror Cover.
- 2) The Mirror rests in place below the Mirror Cover.
- 3) See the Mirror Parts section for instructions on preparing a replacement mirror.

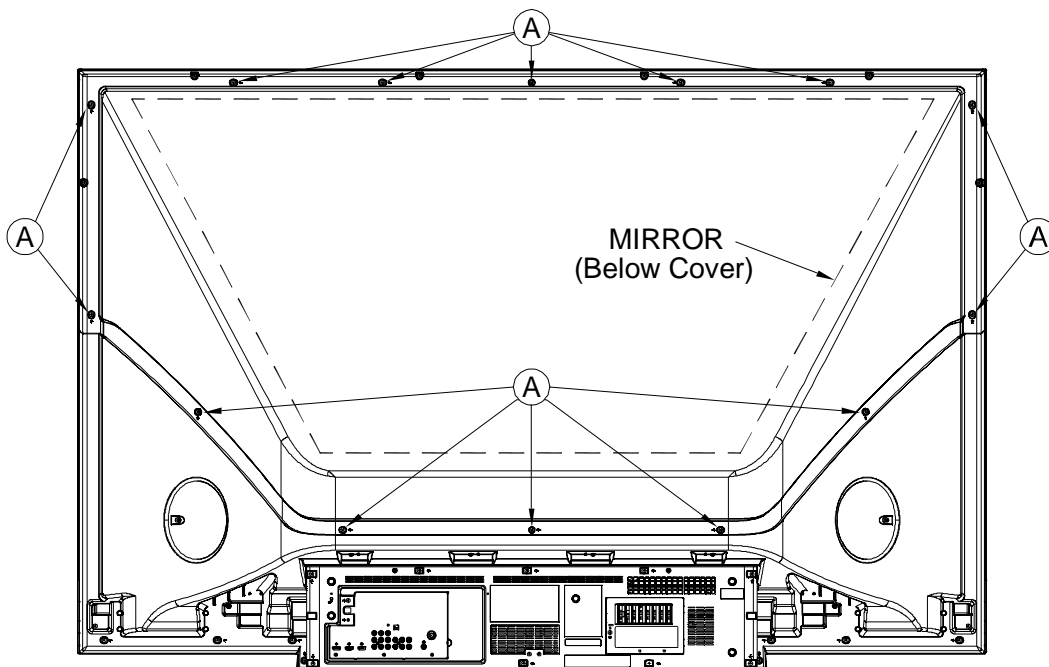

SPEAKER REPLACEMENT

- 1) Remove the Screen Assembly to access the speakers.
- 2) Remove screws (A) and remove the Speaker Assembly from the cabinet.
- 3) Disconnect the leads to the speaker.
- 4) Remove screws (B) to remove the speaker from the speaker cover.
- 5) Reverse the procedure to install a replacement speaker.

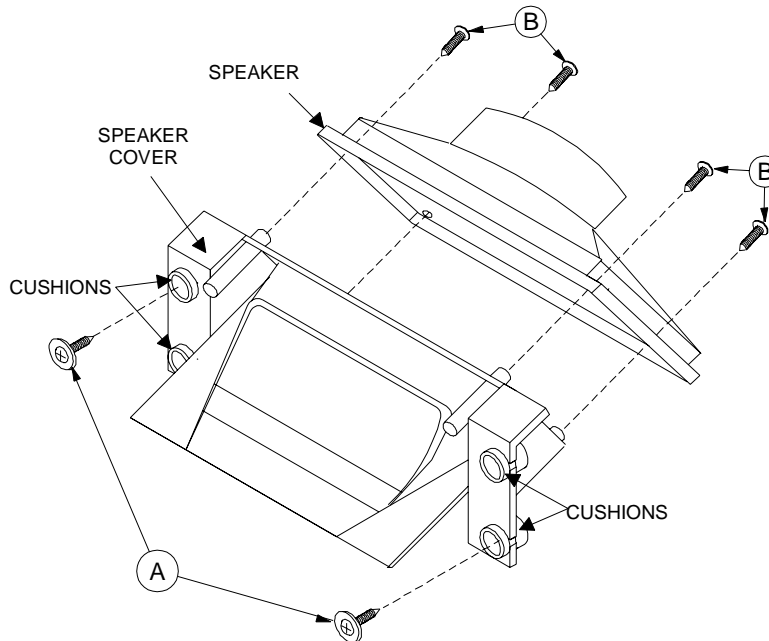

PWB-SBL REPLACEMENT

V41+ Models Only

- 1) Remove the Screen Assembly.
- 2) Remove screws (A) to remove the PWB-SBL assembly.
- 3) Disconnect the electrical connector.
- 3) Release the latches to remove the PWB-SBL from the Holder.
- 4) Reverse the procedure to install a replacement PWB-SBL.

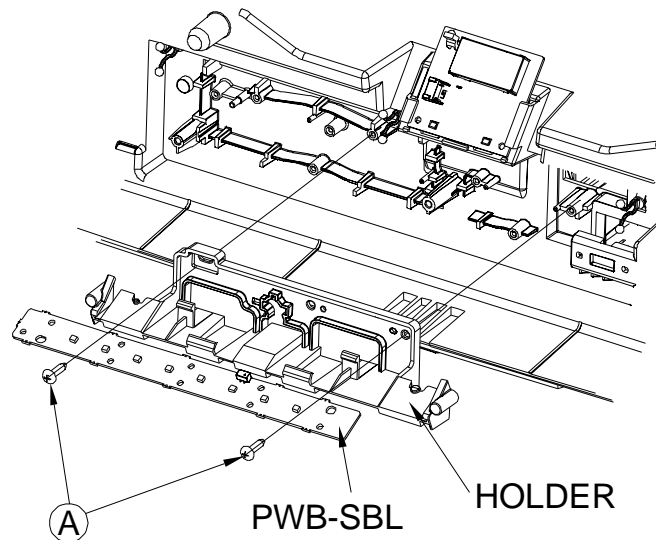

REMOTE CONTROL

REMOTE CONTROL USE FOR SERVICE

Many service functions and adjustments are accessed using the Remote Control.

The V41 uses a new version remote. Service functions and adjustments can be performed with either the old or new versions. However, several buttons have different names or labels.

The remote buttons associated with service that have been changed are shown below with the old buttons' name in parenthesis. For full remote instructions, refer to the Owner's Guide.

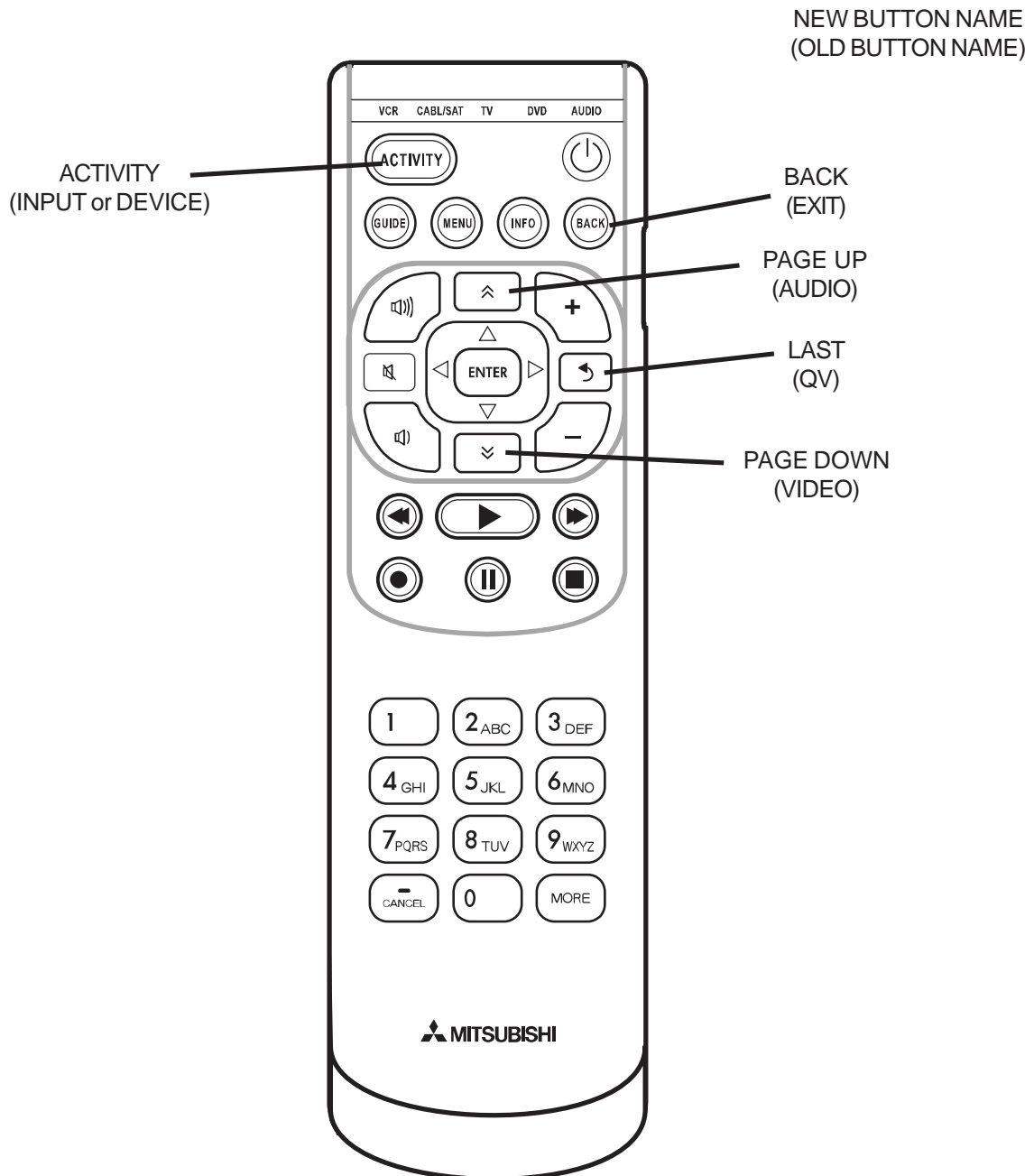

OPTION MENU

OPTION MENU

1. Press the <MENU> button on the remote control.
2. Press the buttons <2-4-7-0>. The screen will display the Option Menu.

Option Menu
<MENU><2-4-7-0>

Initialize	
Power Restore	OFF
Production Mode	OFF
Digital Signal Strength	<1~9>
NetCommand Software	Vxx xxx.xx
Total hours of use	0

DIGITAL SIGNAL STRENGTH

1. Tune to a Digital Channel.
2. From the Option Menu, scroll down and highlight "Digital Signal Strength."
3. Press <ENTER>. The screen will display the Digital Signal Strength Menu.

Digital Signal Strength Menu
"Digital Signal Strength" <ENTER>

	Tuner
Frequency(MHz)	749
Signal Level	<1~9>
Modulation	8VSB Air
Carrier Lock	Locked
SNR	29.09
Correctable errors	0
Un Correctable errors	0

SNR Recommended Levels:

- 8VSB = 16 to 33
- 64 QAM = 22 to 35
- 256 QAM = 27 to 38

RESET / INITIALIZATION

SERVICE TIP:

Many customer generated symptoms, intermittent symptoms or no symptom found can be resolved by using the various Reset and Initialization options. Before visiting the customer's home ask the customer 1st perform a **System Reset** by pressing the **<POWER> button on the front panel and holding it for 8 seconds**. If this does not resolve the issue, they can perform an **AV Reset** by pressing the **<ACTIVITY> + <VOL ◀>** buttons on the front panel at the same time and holding for 10 seconds. Then, if necessary, perform a user level **Initialization** by pressing **<MENU><1-2-3><ENTER>** with the **remote**. The customer should be made aware when settings and/or options will be reset. For more information, see the chart below.

Reset / Initialization Guide

Reset Name	When to use	How to use	Resulting Action
Remote Control TV Layer Reset	Returns the remote control TV layer to normal operation.	<ol style="list-style-type: none"> 1) Set the slide switch to TV position. 2) Press and hold the <POWER> button until it flashes twice then release the button. 3) Enter the code <0-0-9-3-5>. 	Once the valid code has been entered and confirmed, the remote control has been reset.
Remote Control TV Volume/Mute functions	Returns the volume and mute functions of the remote control to TV volume and mute for TV, Cable/Sat, VCR and DVD layers after the Audio Lock for AV Receiver feature has been used.	<ol style="list-style-type: none"> 1) (1) Set the slide switch to TV position. 2) (2) Press and hold the <POWER> button until it flashes twice then release the button. 3) (3) Enter the code <9-9-3>< + >. 	The remote will now operate the TV's volume and mute when the slide switch is in the TV, CABLE/SAT, VCR or DVD positions.
AV Memory Reset, by individual input	When the audio and or video settings for a single input seems to be incorrect.	MENU --> Audio/Video--> AV Reset	All Audio and Video settings for the individual input are reset except for the <i>Listen To, Language, Balance and Closed Caption</i> settings.
AV Reset, all inputs	To reset audio and video adjustments for all inputs to the original factory settings.	While viewing the TV, press the front panel buttons <ACTIVITY> + <VOL ◀> at the same time and hold for 10 seconds.	All Audio and Video settings are reset to the factory default settings. No other menu options are changed.
System Reset	To reset the TV when it does not turn on or off, does not respond to the remote control, front panel buttons or has other unusual symptoms.	Press the <POWER> button on the front panel and hold it for 8 seconds.	TV Micro Re-boots. Note: The changes made during the current TV-On period may be lost. All other previous user settings are not lost.
Initialize User Level	To reset all customer settings except V-Chip	Press <MENU><1-2-3><ENTER>	All customer menu options and AV settings except V-Chip are reset to factory default.
Initialize - Service Level	To reset all customer settings	<MENU><2-4-7-0> . Highlight INITIALIZE and press <ENTER>	All customer menu options and AV settings are reset to factory default.
V-Chip Password Bypass	If V-Chip password is not known	Press < ⏪ > + <9> at the same time.	Password will be bypassed. If in the V-Chip menu, enter a new password.
Unlock Front Panel	To unlock the front panel if it has been locked in the V-Chip Menu.	Press and hold the front panel <ACTIVITY> button for 8 seconds.	Front Panel becomes operational. Other V-Chip settings not changed. Note: Cannot be performed while in the Low Power mode and the set is Off.

RESET / INITIALIZATION (Continued)

INITIAL SETTINGS

Audio/Video		Setup Menu	
<u>Settings</u>		Language (idioma)	English
Video		Scan	
Picture Mode	Brilliant	Ant1 Air	--
Brilliant Contrast	100%	Ant1 Cable	--
Brilliant Brightness	50%	Start	
Color	50%	Edit	
Tint	50%	Channel in Memory	All Added
Sharpness	50%	Name	--
Brilliant Color Temp.	High	FAV1 ~ FAV6	unchecked
Deep Field Imager (V41+)	On	Lock	Unlock
Video Noise (Off-Low-Mid-High)	Medium	Clock	
Audio	(A/V Receiver)	Settings	Manual
Speakers	50%	Time	12:00PM
Bass	50%	Date	1/01/08
Treble	50%	Time Zone	Eastern
Balance	Off	Daylight Savings	Applies
Sound Mode	---	Timer	
Listen To (Analog only)	Normal	Timer	Off
Language (Digital only)	English	Day	Daily
Level Sound	On	Time	12:00PM
Global	Medium	Input	ANT-1
Video Noise(High-Med-Low-Off)	Medium	Channel	2
Video Mute	Auto	Energy	
Audio only screen saver	On	Lamp Mode	Standard
Film Mode	Auto	3D Mode	Gray out
Test Picture	---	Inputs Menu	Standard
Blue Glow (V41+ only)	On if TV On	Name	
3D Mode	Gray out	Ant-1	On
Captions Menu		Input-1	Gray out
<u>Closed Captions</u>		Input-2	Gray out
Analog Captions	On if Mute	Input-3 (Front)	Gray out
Background	Gray	Comp-1	Gray out
Digital Captions	On if Mute	Comp-2	Gray out
Digital Settings		Comp-3 (Front)	Gray out
Font	Default	HDMI-1	Gray out
Font Size	Large	HDMI-2	Gray out
Font Color	White	HDMI-3	Gray out
Font Opacity	Translucent	HDMI-4 (Side) (V41+)	Gray out
Background Color	Black	Order	Gray out
Background Opacity	Translucent	Learn (V41+)	Gray out
Parental Lock Menu		A/V Receiver (V41+)	Gray out
Lock	Off	Learn	Gray out
TV Rating	Gray until On	Learn/Name	Ant-1
Movie Rating	Gray until On	Assign Input 1	--(Gray out for Ant)
Time		Assign Input 2	Gray out until auto
Lock by Time	Off	Assign Input 3	sensing
Lock Time	12:00PM	Assign Input 4	--
Unlock Time	12:00PM	Format	
Front Panel		Ant-1 (HD Digital)	Standard
Front Button Lock	Off	Input-1, 2, 3	Stretch
TV Volume	30	HDMI-1, 2, 3, 4 (Video or PC)	Standard
		USB Photo	--

RESET / INITIALIZATION (Continued)

A. A/V Memory

Each of the external inputs has it's own Audio/Video Memory. A change in an A/V setting at a specific input is stored in memory for that specific input.

B. A/V Reset

1. Press the front panel <ACTIVITY> and <VOL ◀ > buttons at the same time to initialize the A/V Settings for all Inputs.
2. The AV Reset in the user's menu initializes only the A/V Memory for the currently selected input.

A/V Initial Settings

A/V Memory	Ant	Input	Comp	HDMI (Video)	HDMI (PC)	HDMI (PC 3D)	USB (JPEG)
Picture Mode	Brilliant	Brilliant	Brilliant	Brilliant	Bright	Bright	Brilliant
Contrast	MAX	MAX	MAX	MAX	MAX	MAX	MAX
Brightness	Center	Center	Center	Center	Center	Center	Center
Color	Center	Center	Center	Center	Center	Center	Center
Tint	Center	Center	Center	Center	Center	Center	Center
Sharpness	Center	Center	Center	Center	Center	Center	Center
Color Temp.	High	High	High	High	High	High	High
Perfect Color	Center	Center	Center	Center	Center	Center	Center
Perfect Tint (V41+)	Center	Center	Center	Center	Center	Center	Center
Deep Field Imager (V41+)	On	On	On	On	n/a	n/a	On
Video Noise	Medium	Medium	Medium	Medium	Medium	Medium	Medium
Film Mode	Auto	Auto	Auto	Auto	n/a	n/a	n/a
SharpEdge (V41+)	On	On	On	On	On	Off	On
Bass	Center	Center	Center	Center	Center	Center	Center
Treble	Center	Center	Center	Center	Center	Center	Center
Balance	Center	Center	Center	Center	Center	Center	Center
Sound mode	Normal	Normal	Normal	Normal	Normal	Normal	n/a
Listed To	Stereo	n/a	n/a	n/a	n/a	n/a	n/a
Level Sound	On	On	On	n/a	n/a	n/a	n/a
Language (Digital only)	English	n/a	n/a	n/a	n/a	n/a	n/a
Vertical Position	n/a	n/a	n/a	n/a	Center	Center	n/a
Horizontal Position	n/a	n/a	n/a	n/a	Center	Center	n/a

LED INDICATIONS AND SELF DIAGNOSTICS

The front panel Status LED provides an indication of the set's operation and the possible cause of a malfunction.

NORMAL INDICATIONS

STATUS LED Indication	Condition
Off	Off (standby)
Green	Power On
Slow Blink Green	Power Off with Timer Set
Fast Blink Green (80 seconds) > Off	Power Off (Cooling fan still working, 80 sec)

ABNORMAL INDICATIONS (For details perform Self Diagnostics procedure.)

STATUS LED Indication	Condition
Red	Lamp Failure
Yellow	TV Too Hot
Slow Blink Red	TV May Require Service
Slow Blink Yellow	Lamp Door Open or No Lamp Installed

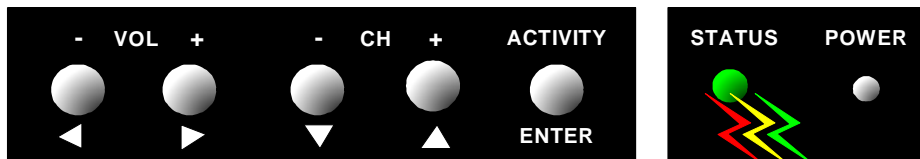

Front Panel (Location and Appearance Differs by Model)

SELF DIAGNOSTICS

To activate, press the front panel <ACTIVITY> + <CH ▼> buttons at the same time and hold for 5 seconds. The STATUS LED will then flash denoting a two digit code.

- The number of flashes indicates the value of the MSD (tens digit) of the Error Code.
 - The flashing then pauses for approximately 1/2 second.
 - The LED then flashes indicating the value of the LSD (ones digit) of the Error Code.
 - The Error Code is repeated a total of 5 times.
- Example: If the Error Code is "23", the LED will flash two times, pause, and then flash three times.

Note: The TV must be in "Shut Down" and the LED will probably be indicating an abnormal condition. If the TV is switched Off, AC is removed, or a System Reset is performed, the code automatically resets to "12" No Error. See the Error Code Log to retrieve a history of errors.

Note: Use the front panel buttons, not the remote control.

Note: If there is no response, the front panel may be locked by a V-Chip setting. To unlock, press and hold <ACTIVITY> on the front panel for 5 seconds.

ERROR CODES

Error Codes, descriptions and the most likely cause of the error are listed below:

ERROR CODES

Code	Description	Most Likely Cause
12	No Error found	
17	Communication loss, TV Micro - Engine (3.3V-ENG-SDA & SCL)	Loss of 12V from PWB-POWER to Engine (Loose PE or PE2 connector). Engine Failure
18	Engine will not accept data (ASIC-READY signal from Engine is not detected).	Engine Failure
32	Lamp cover is open.	Lamp Cover Switch (Loose CD connector)
34	Lamp turns Off while the TV is playing. Lamp failure (Lamp Enable signal from engine is lost)	Lamp Cartridge Failure
36	Exhaust Fan failed.	(Loose J4 connector)
37	Engine (DMD) fan failed.	(Loose J5 connector)
38	Lamp temperature abnormally high.	Poor Air Circulation (Loose J3 connector)
39	DMD temperature abnormally high.	Poor Air Circulation
42	Sirocco fan failed (Lamp fan).	(Loose J8 connector)
44	Check for disconnected DVI cable between PWB-MAIN and Engine. (Engine pulls DVI pin 14 Low)	DVI Cable unplugged
48	PON-SHORT 3.3V or 5V switched supply short	PWB-MAIN Failure
57	Ballast communication problem (ballast to chassis)	Loss of 340V from PWB-POWER to Ballast (Loose PL or CJ1 connector); Loss of communications between PWB-MAIN and Ballast (Loose FB or CJ3 connector). Ballast Failure
61	No LAMP-EN output from the engine to the ballast	Bad Color Wheel (Loose J6 or J7 connector)
66	Lamp did not turn on at P-ON sequence (No Lamp inserted) (Disconnected cable between ballast and lamp) (Lamp-Enable goes to PWB-MAIN but not to Ballast)	(Loose CJ4 connector) No Lamp Inserted. HV connection or lead wire to lamp. Lamp Cartridge Failure

Code 34 - Lamp Enable is generated to activate the Lamp

Code 57 - Lamp Enable is generated during P-ON sequence, but no Lamplit signal is received from the Ballast.

Code 61 - No Lamp Enable is received at the PWB-MAIN and Ballast.

Code 66 - Lamp enable is received at the PWB-MAIN but not at the Ballast.

ERROR CODE LOG

The Error Code Log may be helpful to retrieve the code for an error that occurred in the past.

To access the Error Code Log: Press <MENU> <3-5-6-4>

Error Code Definitions

- PAGE - Current page number
- CURRENT TIME - total hours of operational use.
- LAMP TIME - usage hours when the error occurred.
- CODE - the specific Error Code that occurred.
- STATUS: HAPPENED - Indicates an error was recorded.

Press <CANCEL> to erase the Log.

Note: Lamp Cover errors (32) are not recorded.

***** PAGE (001/001) *****

CURRENT TIME: 01455 HOURS

LAMP TIME CODE STATUS

00413 HRS 57 HAPPENED

00716 HRS 17 HAPPENED

00905 HRS 66 HAPPENED

Press Up to Previous Page

Press Down to Next Page

Press Right to Top Page

Press Left to Last Page

Press CANCEL to Initialize

Press MENU to Exit

NOTE: The Error Code Log is intended as a reference tool and is not meant to be used as a final determination of a defective part.

SERVICE ADJUSTMENTS

There are 4 Service Adjustments:

Electrical Adjustments (there are no mechanical adjustments)

- Horizontal and Vertical Centering Adjustment
- Index Delay Adjustment
- Geometry Alignment
- Data Transfer Functions

Test Equipment and Test Patterns

- Remote Control
- Internally generated Test Patterns
- No external test equipment or pattern generators are required.

SERVICE MODE

The Service Mode is used for all service adjustments.
Service adjustments may only be performed using the remote control.

1. Activating the Service Mode

1. Press the <MENU> button on a remote control. (The “MENU” display will appear.)
 2. Press the buttons <2-4-5-7>. (The Service Mode On Screen Display will appear.)
- If no display appears, press <BACK> and repeat steps 1 and 2.

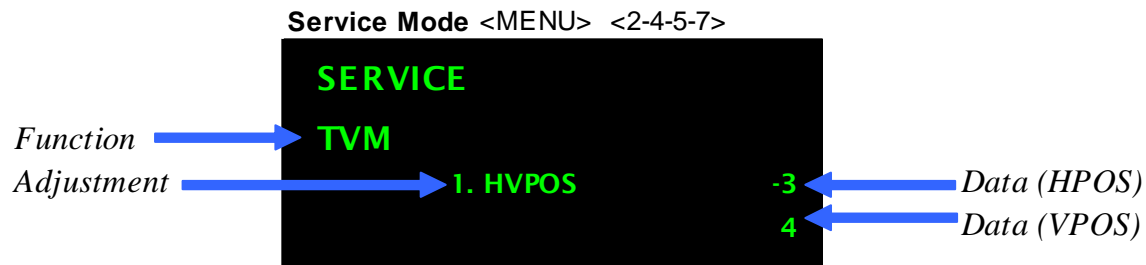

2. Test Pattern Activation

When in the Service Mode, press Play <▶> to activate the internal test patterns (no indication will be displayed initially). Use Fast Forward <▶▶> and Rewind <◀◀> to select a specific pattern.

3. Adjustment Function

Service adjustments are performed in the TVM mode. No other Adjustment Functions are available.

4. Adjustment Selection

Use the Page Down <⌵> button to select a specific electrical adjustment, i.e. “1.HVPOS.”

5. Adjusting Data

After selecting an adjustment item, use the Navigation <▼▲◀▶> buttons to perform the adjustment.

6. Saving Data

Press <ENTER> to save the adjustment data. The menu display will turn red for approximately one second.
Note: If the circuit adjustment mode is terminated without pressing <ENTER>, changes in adjustment data are not saved.

7. Data Transfer & Geometry Menu

While in the Service Mode, press the <0> button to activate the Data Transfer & Geometry Menu.

Horizontal and Vertical Position Adjustment

1. Enter the Service Mode <MENU><2-4-5-7> .
2. Select the Geometry Test Pattern shown below <▷><◀◀> x2.
3. If necessary, select the adjustment, "1.HVPOS" <▽>.

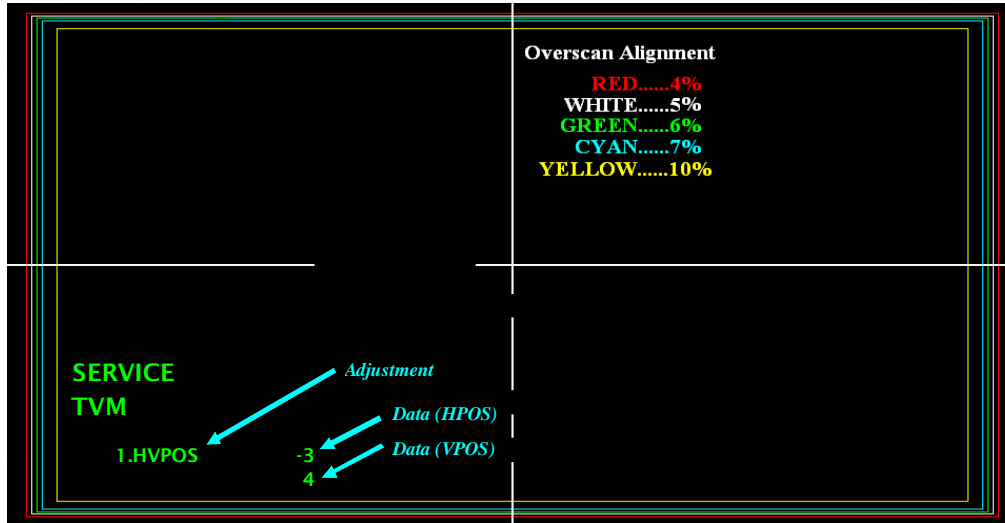

4. After selecting the HVPOS adjustment item, use the Navigation <▼▲◀▶> buttons to center the display.
 - If a Up/Down <▼▲> button is pressed, the vertical position and VPOS adjustment data changes.
 - If a Right/Left <◀▶> button is pressed, the horizontal position and HPOS adjustment data changes.
5. Press <ENTER> to save the adjustment data.

Index Delay Adjustment

1. Enter the Service Mode <MENU><2-4-5-7> .
2. Select the Ramp Pattern shown below <▷><◀◀> x3.
3. Select the adjustment, "60.IDL" <▽>.

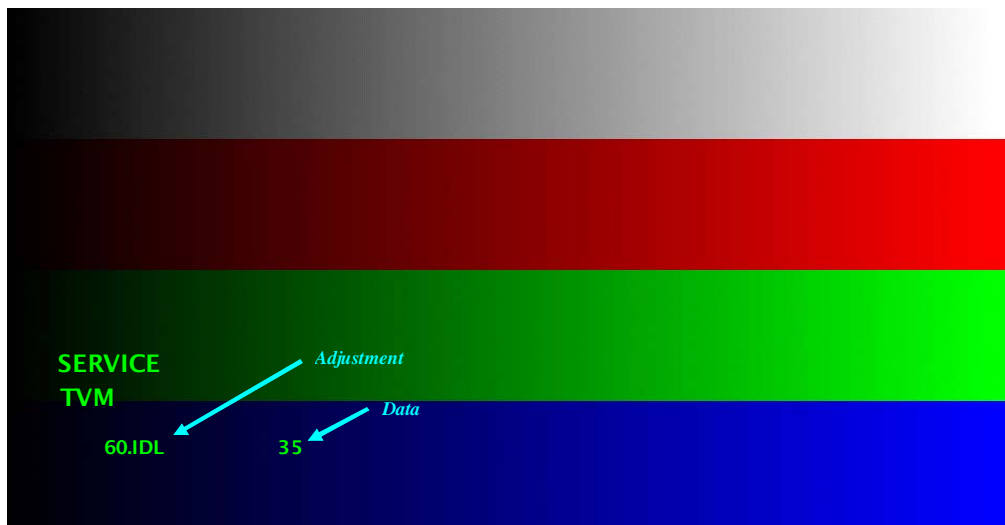

4. After selecting the IDL adjustment item, use the Navigation <▼▲> buttons to adjust the Ramp Pattern color bars so they are smooth and solid. HINT: The data value is typically in the mid 30's.
5. Press <ENTER> to save the adjustment data.

Manual Geometry Alignment

1. Activate the Service Mode <MENU><2-4-5-7>. From the Service Menu, press the <0> button. The Data Transfer & Geometry Menu will appear.
2. Use the <▼▲> buttons to select "MANUAL GEOMETRY ALIGNMENT" and press <ENTER>. The Manual Keystone Geometry Alignment Pattern will appear. See below.

Note: To remove all geometry correction, while the Geometry Alignment Pattern is displayed, press <1> then <ENTER>. This will null all correction data. Then re-enter the Manual Geometry Alignment mode by repeating step 2.

Note: To restore the original factory correction data, select "RESTORE GEOMETRY DATA FROM BACKUP" and press <ENTER>.

Data Transfer & Geometry Menu <MENU><2-4-5-7><0>

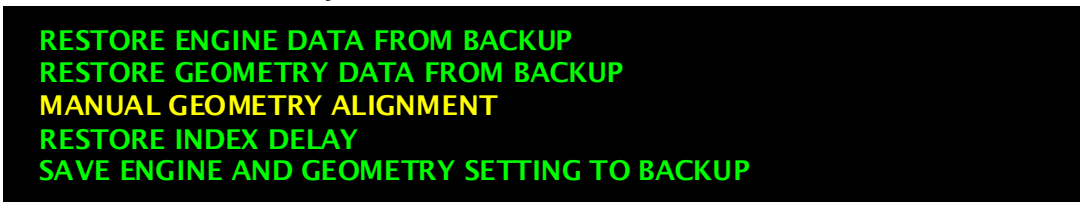

Warning - Only use "SAVE ENGINE AND GEOMETRY SETTING TO BACKUP" after Optical Engine replacement.

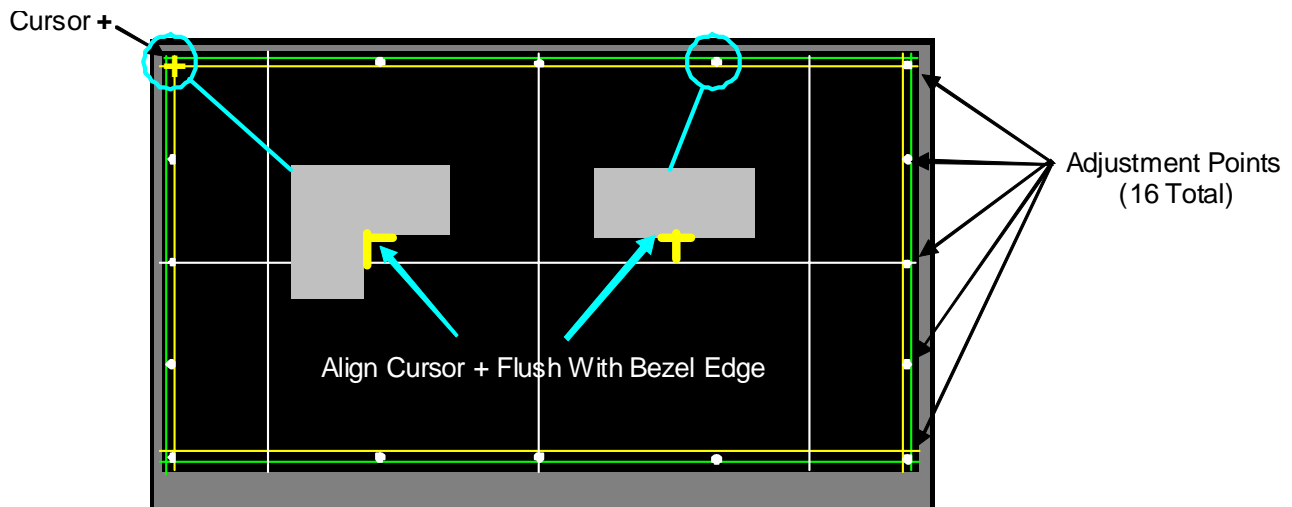

Phase 1 - 16 Point Geometry Alignment

1. 16 Adjustment Points are indicated by white dots around the edge of the raster. The adjustment position is indicated by a + cursor.
2. Starting from the upper left corner, use the <◀▼▲▶> buttons to align the + at each point in a straight line, flush with the bezel as a reference. See example above.
Note: Only the cursor will move. The Geometry Pattern will not change.
3. After adjusting each point, use the <▶▶> button to shift the cursor to the next point clockwise and repeat until all 16 points have been adjusted.
4. After all 16 points are adjusted and the cursor is returned to the original starting point, press <ENTER>. Correction will be automatically calculated and saved and the Manual Geometry Alignment will be terminated.
5. Press <ENTER> to re-activate the Manual Geometry Alignment. The geometry pattern will appear with the corrections applied.

Phase 2 - 4:3 and 16:9 Alignment

1. With the Manual Geometry Alignment activated, press <V> to enter the 4:3 Alignment Mode. The pattern below will be displayed.

Note: Pressing <V> will toggle between the 4:3, 16:9 (top & bottom) and 16 Point Geometry Alignment modes.

2. In the 4:3 Alignment Mode, continuing to press <▶▶> will cause the geometry pattern to be displayed with 11 different preset amounts of correction. Continue pressing <◀◀> or <▶▶> to cycle through the 11 patterns until you find the one with the straightest Blue 4:3 Lines. It may help to count the patterns as you cycle through them. When you find the pattern with the straightest Blue 4:3 Lines, press <V>. The Top 16:9 Alignment Mode will then be activated as indicated by the Top Red 16:9 Line displayed in the pattern.

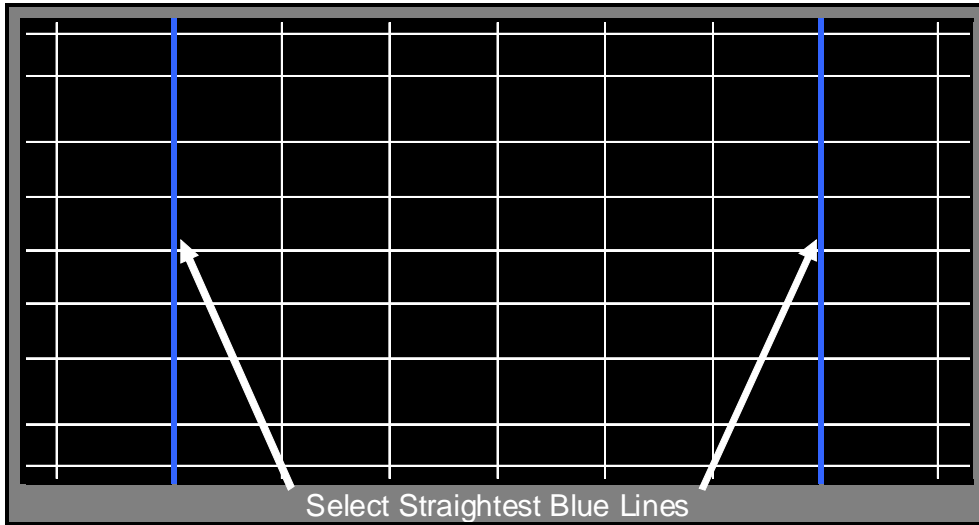

3. In the Top 16:9 Alignment Mode, continuing to press <▶▶> will cause the geometry pattern to be displayed with 15 different preset amounts of correction to the Top Red 16:9 Line. Continue pressing <◀◀> or <▶▶> to cycle through the 15 patterns until you find the one with the straightest Top Red 16:9 Line. Again, count the patterns as you cycle through them. When you find the pattern with the straightest line, press <V>. The Bottom 16:9 Alignment Mode will then be activated as indicated by the Bottom Red 16:9 Line displayed in the pattern.

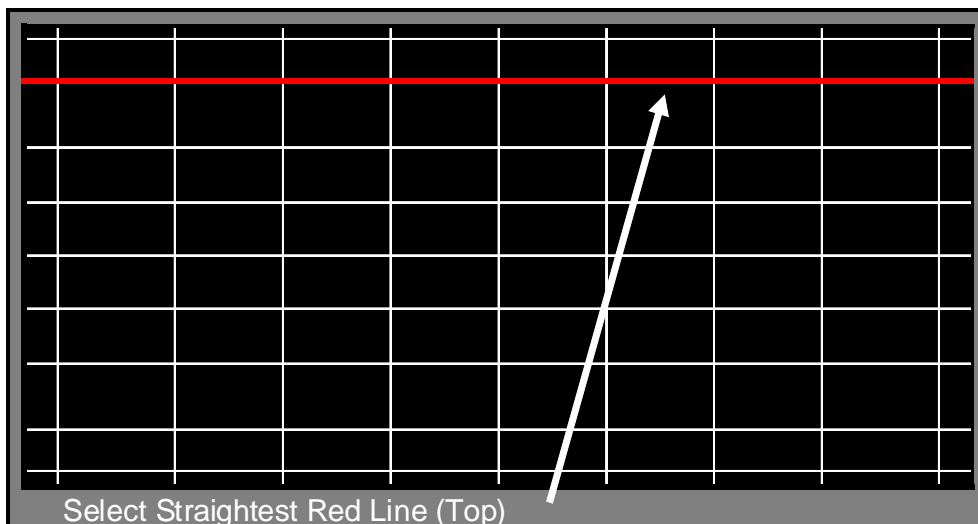

4. In the Bottom 16:9 Alignment Mode, continuing to press <▶▶> will cause the geometry pattern to be displayed with 10 different preset amounts of correction to the Bottom Red 16:9 Line. Continue pressing <◀◀> or <▶▶> to cycle through the 10 patterns until you find the one with the straightest Bottom Red 16:9 Line. Again, count the patterns as you cycle through them. When you find the pattern with the straightest line, press <ENTER> to exit and save the 4:3 and 16:9 data.
5. Select the Geometry Test Pattern (See HVPOS). If Geometry is acceptable, press <BACK> to quit. To touch-up the raster geometry, proceed.

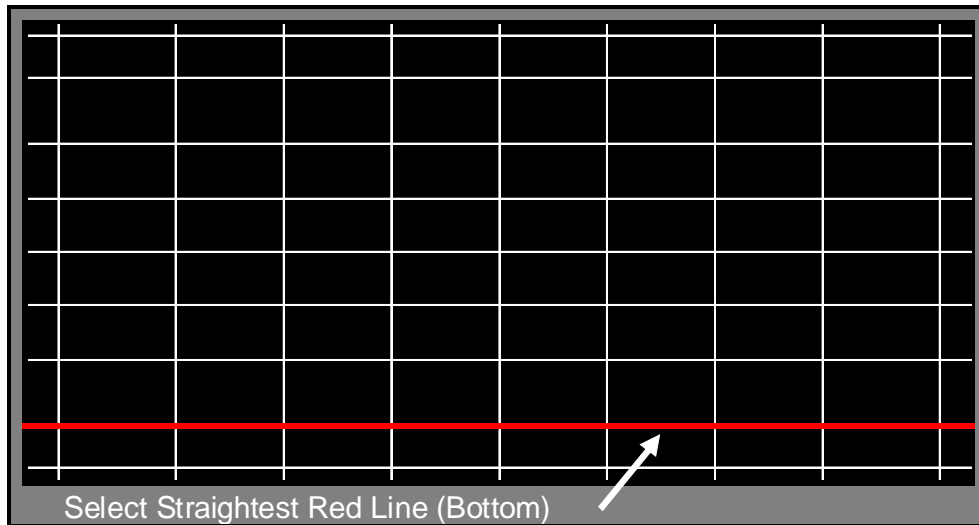

Phase 3 - Geometry Touch-up Alignment

1. Enter the Manual Geometry Alignment mode.
2. Use the <◀◀> or <▶▶> button to shift the cursor to the point needing correction.
3. Use the <◀▼▲▶> buttons to indicate the direction and amount of correction necessary at the particular point. Note: Only the cursor will move. The Geometry Pattern will not change.
4. Press the <INFO> button to apply the correction. The Geometry Pattern will now show the correction.
5. Repeat steps 2, 3 and 4 as needed.
6. Press <ENTER> to save your changes. The Manual Geometry Alignment will be terminated.
7. Press <BACK> to exit the alignment mode.

Data Transfer

Service Data is duplicated and stored in separate EEPROMs in two locations.

- PWB-MAIN - Working data for TV operation
- OPTICAL ENGINE - Backup data

The Optical Engine also includes data for the Color Wheel Index Delay setting determined at the factory.

Procedure:

1. Enter the Service Mode <MENU><2-4-5-7> Select the Data Transfer & Geometry Menu <0>

Data Transfer & Geometry Menu <MENU><2-4-5-7><0>

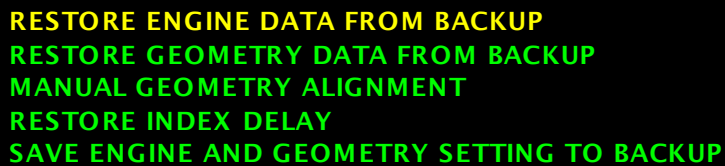

RESTORE ENGINE DATA FROM BACKUP
RESTORE GEOMETRY DATA FROM BACKUP
MANUAL GEOMETRY ALIGNMENT
RESTORE INDEX DELAY
SAVE ENGINE AND GEOMETRY SETTING TO BACKUP

Warning - Only use "SAVE ENGINE AND GEOMETRY SETTING TO BACKUP" after Optical Engine replacement.

Note: Besides *MANUAL GEOMETRY ALIGNMENT*, four data transfer choices are listed on screen.

- *RESTORE ENGINE DATA FROM BACKUP* - copies backup factory adjustments HVPOS, White Balance and Index Delay from the Optical Engine to the PWB-MAIN.
 - *RESTORE GEOMETRY DATA FROM BACKUP* - copies backup factory Geometry Alignment data from the Optical Engine to the PWB-MAIN.
 - *RESTORE INDEX DELAY* - copies factory Index Delay Adjustment data from the Optical Engine to the PWB-MAIN.
 - *SAVE ENGINE AND GEOMETRY SETTING TO BACKUP* - copies all working data from the PWB-MAIN into backup memory on the Optical Engine.
2. Use the <▼▲> buttons to select the data transfer item and press <ENTER>.
 3. Press <BACK> to quit.

After Engine Replacement:

1. *Restore Index Delay.*
2. *Save Engine and Geometry Setting to Backup*

After PWB-MAIN Replacement:

1. *Restore Engine Data From Backup*
2. *Restore Geometry Data From Backup.*

Using Lead Free Solder

The symbol shown below indicates Lead (Pb) Free solder was used during the construction of PWBs. **Only Lead Free solder** should be used when servicing these PWBs.

Solder must be compatible with that used by the manufacturer. Leaded solder can not be used on PWBs manufactured with Pb-free solder. The Mitsubishi standard for service requires the use of Tin-Silver-Copper (Sn-96.5, Ag-3.0, Cu-0.5). It can be obtained through the Parts Department.
Order part number: **PB FREE SOLDER**

Lead Free solder has a higher melting point, and does not “wet” as well as leaded solder. This means it does not adhere as readily to the solder iron tip, and the surface to be soldered. To counteract this, the flux used is more corrosive.

The following cautions must be taken when using Pb Free solder.

- Higher temperatures can cause the PWB to warp, detaching surface mount components.
- Higher temperatures may cause thermal damage to components.
- Higher temperatures can cause plastics, such as connectors, relays, LEDs electrolytic capacitors, etc. to melt or warp.
- Higher temperatures can cause surface oxidation resulting in poor solder spread-ability and wet-ability.
- The flux is more corrosive.
- The time required for a good solder connection may take longer.

- Poor wet-ability can cause solder balls.
- Higher temperatures can cause flux spattering.
- Soldering iron tip life is shortened.
- Dull finish solder joints (not shiny) can appear to be a “cold” solder joint.

In general a tip temperature of 700° F will usually provide good results.

Displays used to indicate Pb-free

PCBs will be marked, indicating the level of Pb-free construction. *Table 1* defines the levels by phase and shows the different symbols that will be displayed on the PCB. Additionally, a PCB constructed using Pb-free solder may be simply marked **LFS**.

When possible, the indication will be placed close to the part number that is screened onto the PCB (not the part label). *Figure 1* is an example of a PCB showing the display and its location.







Pb-Free Phase	Definition	Display	Short Display (When the area is too small)
Phase-1	PCB's constructed using Pb-free solder.		
Phase-2	Solder, PCB surface finishing and component lead plating is Pb-free. Components may have internal Pb.		
Phase-3	Solder, PCB surface finishing and components are Pb-free. (100% Pb-free)		

Table 1: Pb-Free Phases and Symbols



Pb-Free Display

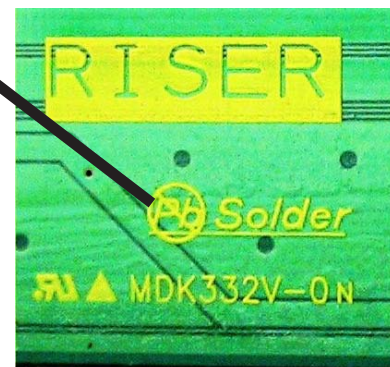

Figure 1: Pb-Free display on PWB

CHIP PARTS REPLACEMENT

Some resistors, shorting jumpers (0 Ohm resistors), ceramic capacitors, transistors and diodes are chip parts. The following precautions should be taken when replacing these parts.

Cautions:

1. Use a fine tipped, well insulated soldering iron and tweezers.
2. Melt the solder and remove the chip parts carefully so as not to tear the copper foil from the printed circuit board.
3. Discard removed chips; do not reuse them.
4. Do not apply heat for more than 3 (three) seconds to new chip parts.
5. Avoid using a rubbing stroke when soldering.
6. Take care not to scratch, or damage the chip parts when soldering.
7. Supplementary cementing is not required.

Chip Parts Removal (Resistors, Capacitors, etc.)

1. Grasp the part with tweezers. Melt the solder at both sides alternately, and remove one side of the part with a twisting motion.
2. Melt the solder at the other side and remove the part.

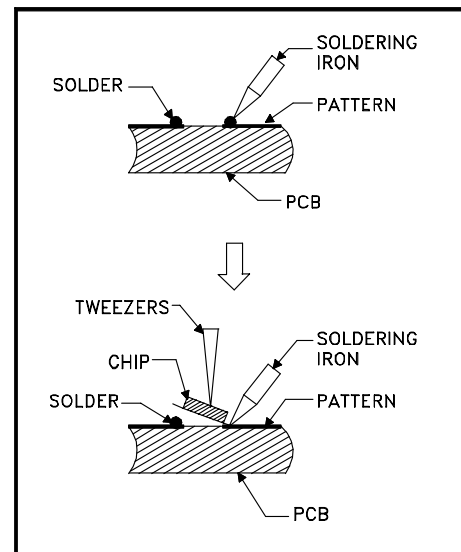
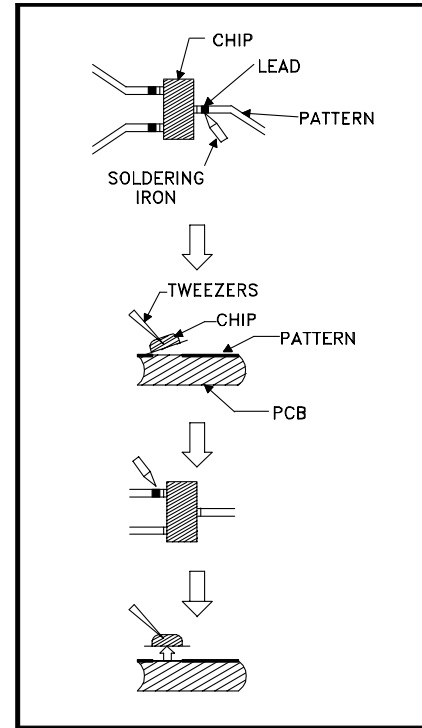
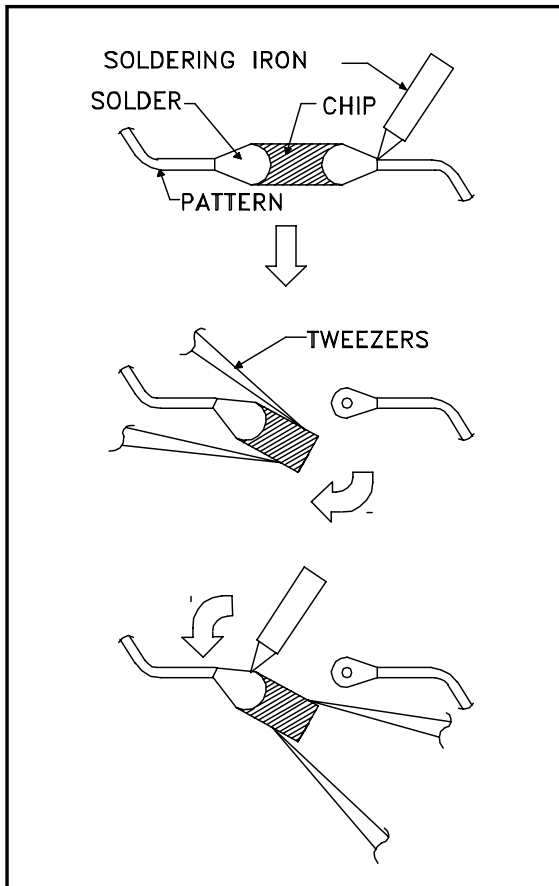

REPLACEMENT PARTS

Parts Ordering

To expedite delivery of replacement parts orders, specify the following:

1. Model Number/Serial Number
2. Part Number and description
3. Quantity

Note: Unless complete information is supplied, delay in processing of orders will result.

Safety Critical Parts Designation

Safety Critical Components are indicated in the Parts List by **Bold Type** and a Δ icon, and in the schematic diagrams by a red hatch  and a Δ .

Parts Tolerance Codes

MARK	B	C	D	F	G	J	K
Tolerance %	± 0.1	± 0.25	± 0.5	± 1	± 2	± 5	± 10

MARK	M	N	V	X	Z	P	Q
Tolerance %	± 20	± 30	± 10	+ 40 -20	+ 80 -20	+ 100 - 0	+ 30 -10

MARK	M	N	V	X	Z
Tolerance (pF)	± 0.1	± 0.25	± 0.5	± 1	± 2

QUICK REFERENCE

ALL MODELS

PART	PART NUMBER
Lamp-Cartridge	915B403001 Δ
Lamp Ballast	938P127010 Δ
Speaker	480P084020
Fan-Exhaust	299P335010
Fan-Scirocco (Lamp)	299P321010
Fan-Engine (DMD)	299P339010
Sensor-Temperature	299P337010
Module-Color-Wheel	938P137010

PRINTED CIRCUIT BOARDS

MODEL	PWB-MAIN	PWB-POWER	PWB-LAMP-SW	PWB-CONT	PWB-LED	PWB-RS232	PWB-PREAMP
WD-60737	934C328001	934C329001	934D059001	934D060001	934D057001	X	934D058001
WD-60C9	"	"	"	"	"	X	"
WD-65737	"	"	"	"	"	X	"
WD-65C9	"	"	"	"	"	X	"
WD-73737	"	"	"	"	"	X	"
WD-73C9	"	"	"	"	"	X	"
WD-82737	"	"	"	934D060002	X	X	"
WD-65837	934C328002	"	"	"	X	934D062001	934D058002
WD-73837	"	"	"	"	X	"	"
WD-82837	"	"	"	"	X	"	"

OPTICAL ENGINE & MISC. PARTS

MODEL	OPTICAL ENGINE	FRESNEL LENS	LENTICULAR SCREEN	MIRROR KIT	PROJECTION LENS	REMOTE
WD-60737	938P158010	491P218010	491P217040	KIT-MIR V41 60"	491P240010	290P175010
WD-60C9	"	"	"	"	"	"
WD-65737	938P158020	491P218020	491P217050	KIT-MIR V41 65"	"	"
WD-65837	955B378003	"	"	"	"	"
WD-65C9	938P158020	"	"	"	"	"
WD-73737	938P158030	491P218030	491P217060	KIT-MIR V41 73"	"	"
WD-73C9	"	"	"	"	"	"
WD-73837	955B378004	"	"	"	"	"
WD-82737	938P158040	491P231010	491P231010	KIT-MIR V41 82"	"	"
WD-82837	955B378005	"	"	"	"	"

**MODELS: WD-60C9 / WD-73C9 / WD-60737 / WD-65737 / WD-73737 / WD-82737
WD-65837 / WD-73837 / WD-82837**

[#] Model Legend: (a) WD-60737, (b) WD-60C9, (c) WD-65737, (d) WD-65837, (e) WD-65C9,
(f) WD-73737, (g) WD-73837, (h) WD-73C9, (i) WD-82737, (j) WD-82837

Ref #	Part #	Part Name & Description	△	[#]
INTEGRATED CIRCUITS				
IC1B01	271P171010	IC - MIC2040-1YMM		
IC1B02	265P151010	VARISTOR - AVF16C225A000F405		
IC2A01	276P726010	IC-C-MOS - SiI9287CNU		
IC2A51	276P742020	IC-C-MOS - PST8428NR		
IC3A00	276P733010	IC-C-MOS - YDA156-VZ		
IC3C00	276P741010	IC-C-MOS - AK4420ETP		
IC4A01	276P742020	IC-C-MOS - PST8428NR		
IC4A02	276P687010	IC-C-MOS - BCM3549LKFSB5G		
IC4F01	276P744010	IC-C-MOS - NT5TU64M16DG-AC		
IC4F02	271P033020	IC - LP2996LQNOPB		
IC4F03	276P744010	IC-C-MOS - NT5TU64M16DG-AC		
IC4G01	271P251040	IC - MM1662FHBE		
IC4L01	276P485010	IC-C-MOS - SC16C652BIB48		
IC4L02	276P740010	IC-C-MOS - LC4064ZE-7TN48C		
IC4L03	276P545090	IC-C-MOS - NAND01GW3B2CN6E-P		
IC4L05	276P628010	IC-C-MOS - PL671-33-120SC-R		
IC5A01	276P722010	IC-C-MOS - UPD808526F1-S11-MNJ-A		
IC5A02	271P319010	IC - MM1701AHBE		
IC5A03	271P319010	IC - MM1701AHBE		
IC6C00	276P336010	IC-C-MOS - SiI7170CMHU		
IC6C02	271P251020	IC - MM1663DHBE		
IC7A01	276P576010	IC-C-MOS - UPD78F1178GF(S)-GAT-AX		
IC7A03	276P578020	IC-C-MOS - MM3376A33NRE		
IC7E01	276P519010	IC-C-MOS - 74HC132DB		dgi
IC8300	276P525010	IC-C-MOS - MAX4489ASA+T		dgi
IC9010267P324010	HIC - STR-W6754		△	
IC9020271P142010	IC - RT9H301C		△	
IC9030271P315010	HIC - STR-A6159		△	
IC9031271P142010	IC - RT9H301C		△	
IC9A01	271P254010	IC - ISL6545ACBZ-TS2698		
IC9A02	271P254010	IC - ISL6545ACBZ-TS2698		
IC9A03	271P254010	IC - ISL6545ACBZ-TS2698		
IC9A04	276P578020	IC-C-MOS - MM3376A33NRE		
IC9A06	271P321010	IC - PST8242NR		
IC9A07	271P321010	IC - PST8242NR		
IC9E01	275P989010	IC-C-MOS - MAX3223ECAP		dgi
IC9G80	271P171010	IC - MIC2040-1YMM		
TRANSISTORS				
CHIP Type Transistors (Listed by Part No.)				
	Part No.	Description		
	261P842080	2SC3052-T112-1E;F		
	261P844010	RT1N436C-T112-1		
	261P845010	RT1P241C-T1112-1		
	261P875010	FDS8984		
	261P877010	FDC655BN		
	261P878010	RT3Y97M-T111-1		
	261P881010	2SB1424T100R		
	261P889010	ISA1235AC1-T112A-1E,1F		

Ref #	Part #	Part Name & Description	△	[#]
DIODES				
D2A11	262P880080	DIODE-CHIP - MAZ8051GHL		
D2A12	262P830010	D-CHIP - MC2850-T111-1		
D2A13	262P830010	D-CHIP - MC2850-T111-1		
D2A21	262P880080	DIODE-CHIP - MAZ8051GHL		
D2A22	262P830010	D-CHIP - MC2850-T111-1		
D2A23	262P830010	D-CHIP - MC2850-T111-1		
D2A31	262P880080	DIODE-CHIP - MAZ8051GHL		
D2A32	262P830010	D-CHIP - MC2850-T111-1		
D2A33	262P830010	D-CHIP - MC2850-T111-1		
D2A41	262P880080	DIODE-CHIP - MAZ8051GHL		dgi
D2A42	262P830010	D-CHIP - MC2850-T111-1		dgi
D2A43	262P830010	D-CHIP - MC2850-T111-1		dgi
D2A52	262P830010	D-CHIP - MC2850-T111-1		
D4A03	262P163010	D-CHIP - MALS068X0L		
D4A04	262P163010	D-CHIP - MALS068X0L		
D4A05	262P830010	D-CHIP - MC2850-T111-1		
D4A06	262P830010	D-CHIP - MC2850-T111-1		
D4A07	262P163010	D-CHIP - MALS068X0L		
D4A08	262P163010	D-CHIP - MALS068X0L		
D7A03	262P830010	D-CHIP - MC2850-T111-1		
D7A04	262P828020	D-CHIP - MC2836-T112-1		
D8000	264P584020	DIODE-LE - SML1216W-C,D		dgi
D8200	264P584020	DIODE-LE - SML1216W-C,D		abcefh
D8300	262P828010	D-CHIP - MC2838-T112-1		dgi
D8301	268P100010	DIODE-PHOTO - SFH235FA		dgi
D8701	262P855010	D-LE-CHIP - LB E6SG-S2U1-35-1		dgi
D8702	262P855010	D-LE-CHIP - LB E6SG-S2U1-35-1		dgi
D8703	262P855010	D-LE-CHIP - LB E6SG-S2U1-35-1		dgi
D8704	262P855010	D-LE-CHIP - LB E6SG-S2U1-35-1		dgi
D8705	262P855010	D-LE-CHIP - LB E6SG-S2U1-35-1		dgi
D8706	262P855010	D-LE-CHIP - LB E6SG-S2U1-35-1		dgi
D8707	262P855010	D-LE-CHIP - LB E6SG-S2U1-35-1		dgi
D8708	262P855010	D-LE-CHIP - LB E6SG-S2U1-35-1		dgi
D9001	262P200010	DIODE - D6SB80-7001		△
D9005	262P170010	DIODE - SARS01		
D9006	262P203070	DIODE - UF4007		
D9008	262P201060	DIODE - 1N4006		△
D9009	262P201060	DIODE - 1N4006		△
D9010	262P201060	DIODE - 1N4006		△
D9011	262P201060	DIODE - 1N4006		△
D9012	264P045080	DIODE - 1S2076A/1S24710M		
D9013	262P084010	DIODE - 31DQ06		
D9014	264P774020	DIODE - MTZJ4.7A,B,CQLF		
D9018	264P045080	DIODE - 1S2076A/1S24710M		
D9019	264P045080	DIODE - 1S2076A/1S24710M		
D9020	264P045080	DIODE - 1S2076A/1S24710M		
D9022	264P775080	DIODE - MTZJ6.2CQLF		
D9023	262P085010	DIODE - 11EFS2N-TA2B5		
D9024	262P085010	DIODE - 11EFS2N-TA2B5		
D9026	262P208010	DIODE - FCHS10A12-15A		△
D9031	262P210010	DIODE - 30PHA20-FC5		△
D9A01	262P852010	D-CHIP - BAT54S		
D9A02	262P852010	D-CHIP - BAT54S		
D9A03	262P882020	DIODE-CHIP - MAZ8160GHL		
D9A04	262P882010	DIODE-CHIP - MAZ8150GHL		
D9A06	262P828010	D-CHIP - MC2838-T112-1		
D9A08	262P828010	D-CHIP - MC2838-T112-1		
D9A09	262P900010	DIODE - FLZ3V9A T&R 2500/reel		

**MODELS: WD-60C9 / WD-65C9 / WD-73C9 / WD-60737 / WD-65737 / WD-73737 / WD-82737
WD-65837 / WD-73837 / WD-82837**

[#] Model Legend: (a) WD-60737, (b) WD-60C9, (c) WD-65737, (d) WD-65837, (e) WD-65C9,
(f) WD-73737, (g) WD-73837, (h) WD-73C9, (i) WD-82737, (j) WD-82837

Ref #	Part #	Part Name & Description	△	[#]
COILS				
L1A02	409P975010	CHIP BEADS - MPZ2012S221A		
L1A04	325C420070	COIL-CHIP - 10MH-K LOW-R		
L1B01	409P975010	CHIP BEADS - MPZ2012S221A		
L1B02	409P975010	CHIP BEADS - MPZ2012S221A		
L1B03	409P979010	EMI-FILTER-CHIP - DLW21SN900SQ2L		
L2A01	409P974010	CHIP BEADS - MMZ1608S601A		
L2A92	409P975010	CHIP BEADS - MPZ2012S221A		
L3A11	409P974010	CHIP BEADS - MMZ1608S601A		
L3A13	409P974010	CHIP BEADS - MMZ1608S601A		
L3A25	351P317010	COIL-CHOKE-CHIP - PLC-1055-220S		
L3A28	351P317010	COIL-CHOKE-CHIP - PLC-1055-220S		
L3A33	351P317010	COIL-CHOKE-CHIP - PLC-1055-220S		
L3A36	351P317010	COIL-CHOKE-CHIP - PLC-1055-220S		
L3C12	409P974010	CHIP BEADS - MMZ1608S601A		
L4A01	325C505060	COIL-CHIP - MLF2012A2R7J		
L4A06	409P974010	CHIP BEADS - MMZ1608S601A		
L4F01	409P974010	CHIP BEADS - MMZ1608S601A		
L4F02	409P974010	CHIP BEADS - MMZ1608S601A		
L4G01	409P975010	CHIP BEADS - MPZ2012S221A		
L4G02	409P975010	CHIP BEADS - MPZ2012S221A		
L4G03	409P975010	CHIP BEADS - MPZ2012S221A		
L4G04	409P975010	CHIP BEADS - MPZ2012S221A		
L4G05	409P975010	CHIP BEADS - MPZ2012S221A		
L4G06	409P975010	CHIP BEADS - MPZ2012S221A		
L4G07	409P975010	CHIP BEADS - MPZ2012S221A		
L4G08	409P975010	CHIP BEADS - MPZ2012S221A		
L4G09	409P974010	CHIP BEADS - MMZ1608S601A		
L4G10	409P974010	CHIP BEADS - MMZ1608S601A		
L4G11	409P974010	CHIP BEADS - MMZ1608S601A		
L4G12	409P974010	CHIP BEADS - MMZ1608S601A		
L4G15	409P974010	CHIP BEADS - MMZ1608S601A		
L4G16	409P974010	CHIP BEADS - MMZ1608S601A		
L4G17	409P974010	CHIP BEADS - MMZ1608S601A		
L4G18	409P974010	CHIP BEADS - MMZ1608S601A		
L4G19	409P974010	CHIP BEADS - MMZ1608S601A		
L4G20	409P974010	CHIP BEADS - MMZ1608S601A		
L4G21	409P974010	CHIP BEADS - MMZ1608S601A		
L4G24	409P974010	CHIP BEADS - MMZ1608S601A		
L4G25	325C421020	COIL-CHIP - 68MH-K LOW-R		
L4L01	409P975010	CHIP BEADS - MPZ2012S221A		
L4L02	409P974010	CHIP BEADS - MMZ1608S601A		
L4L03	409P974010	CHIP BEADS - MMZ1608S601A		
L4L04	409P974010	CHIP BEADS - MMZ1608S601A		
L4L05	409P974010	CHIP BEADS - MMZ1608S601A		
L5A01	409P975010	CHIP BEADS - MPZ2012S221A		
L5A02	409P975010	CHIP BEADS - MPZ2012S221A		
L5F06	409P974010	CHIP BEADS - MMZ1608S601A		

Ref #	Part #	Part Name & Description	△	[#]
L5F07	409P974010	CHIP BEADS - MMZ1608S601A		
L6C00	409P974010	CHIP BEADS - MMZ1608S601A		
L6C01	409P974010	CHIP BEADS - MMZ1608S601A		
L6C02	409P974010	CHIP BEADS - MMZ1608S601A		
L6C03	409P974010	CHIP BEADS - MMZ1608S601A		
L6C04	409P974010	CHIP BEADS - MMZ1608S601A		
L6C05	409P974010	CHIP BEADS - MMZ1608S601A		
L6C06	409P974010	CHIP BEADS - MMZ1608S601A		
L6C08	409P974010	CHIP BEADS - MMZ1608S601A		
L6C14	409P975010	CHIP BEADS - MPZ2012S221A		
L6C24	409P974010	CHIP BEADS - MMZ1608S601A		
L6C46	409P974010	CHIP BEADS - MMZ1608S601A		
L6C94	409P974010	CHIP BEADS - MMZ1608S601A		
L7A01	409P974010	CHIP BEADS - MMZ1608S601A		
L7A02	409P974010	CHIP BEADS - MMZ1608S601A		
L7C02	409P974010	CHIP BEADS - MMZ1608S601A		dgj
L7C03	409P974010	CHIP BEADS - MMZ1608S601A		dgj
L8300	409P975010	CHIP BEADS - MPZ2012S221A		
L9001	351P351010	LINE-FILTER - SC22-05-70J	△	
L9002	351P351010	LINE-FILTER - SC22-05-70J	△	
L9005	321C141010	COIL-RF - 6.8MH-M		
L9A01	409P975010	CHIP BEADS - MPZ2012S221A		
L9A02	409P975010	CHIP BEADS - MPZ2012S221A		
L9A03	409P975010	CHIP BEADS - MPZ2012S221A		
L9A05	351P349010	COIL-CHOKE-CHIP - CDRH8D43NP-2R0NC		
L9A06	409P975010	CHIP BEADS - MPZ2012S221A		
L9A07	351P349010	COIL-CHOKE-CHIP - CDRH8D43NP-2R0NC		
L9A11	409P974010	CHIP BEADS - MMZ1608S601A		
L9A12	409P974010	CHIP BEADS - MMZ1608S601A		
L9A13	409P974010	CHIP BEADS - MMZ1608S601A		
L9A14	409P974010	CHIP BEADS - MMZ1608S601A		
L9A15	409P974010	CHIP BEADS - MMZ1608S601A		
L9A16	409P975010	CHIP BEADS - MPZ2012S221A		
L9A17	351P349010	COIL-CHOKE-CHIP - CDRH8D43NP-2R0NC		
L9A18	409P974010	CHIP BEADS - MMZ1608S601A		
L9E03	325C411090	COIL-CHIP - 33MH-J		dgj
L9G80	409P975010	CHIP BEADS - MPZ2012S221A		
L9G81	409P974010	CHIP BEADS - MMZ1608S601A		
T4G01	409P978010	EMI-FILTER-CHIP - DLP2ADN900HL4L		
T4G02	409P978010	EMI-FILTER-CHIP - DLP2ADN900HL4L		
T4G03	409P978010	EMI-FILTER-CHIP - DLP2ADN900HL4L		
T4G04	409P978010	EMI-FILTER-CHIP - DLP2ADN900HL4L		
T4G05	409P978010	EMI-FILTER-CHIP - DLP2ADN900HL4L		
T4G06	409P978010	EMI-FILTER-CHIP - DLP2ADN900HL4L		
T6C01	409P978010	EMI-FILTER-CHIP - DLP2ADN900HL4L		
T6C02	409P978010	EMI-FILTER-CHIP - DLP2ADN900HL4L		
TRANSFORMERS				
T9010	350P865010	TRANS-PWR - SRW2630EG-U04H016	△	
T9030	350P867010	TRANS-PWR - SRW16ES-U37V014	△	

**MODELS: WD-60C9 / WD-65C9 / WD-73C9 / WD-60737 / WD-65737 / WD-73737 / WD-82737
WD-65837 / WD-73837 / WD-82837**

[#] Model Legend: (a) WD-60737, (b) WD-60C9, (c) WD-65737, (d) WD-65837, (e) WD-65C9,
(f) WD-73737, (g) WD-73837, (h) WD-73C9, (i) WD-82737, (j) WD-82837

Ref #	Part #	Part Name & Description	△	[#]
VARISTORS				
RV9000	265P100040	VARISTOR - ERZV10D471CS	△	
RV9001	265P100040	VARISTOR - ERZV10D471CS	△	
VR2A11	265P151010	VARISTOR - AVF16C225A000F405		
VR2A12	265P151010	VARISTOR - AVF16C225A000F405		
VR2A13	265P151010	VARISTOR - AVF16C225A000F405		
VR2A14	265P151010	VARISTOR - AVF16C225A000F405		
VR2A21	265P151010	VARISTOR - AVF16C225A000F405	abcephi	
VR2A21	265P151010	VARISTOR - AVF16C225A000F405	dgi	
VR2A22	265P151010	VARISTOR - AVF16C225A000F405	abcephi	
VR2A22	265P151010	VARISTOR - AVF16C225A000F405	dgi	
VR2A23	265P151010	VARISTOR - AVF16C225A000F405	abcephi	
VR2A23	265P151010	VARISTOR - AVF16C225A000F405	dgi	
VR2A24	265P151010	VARISTOR - AVF16C225A000F405	abcephi	
VR2A24	265P151010	VARISTOR - AVF16C225A000F405	dgi	
VR2A31	265P151010	VARISTOR - AVF16C225A000F405	abcephi	
VR2A31	265P151010	VARISTOR - AVF16C225A000F405	dgi	
VR2A32	265P151010	VARISTOR - AVF16C225A000F405	abcephi	
VR2A32	265P151010	VARISTOR - AVF16C225A000F405	dgi	
VR2A33	265P151010	VARISTOR - AVF16C225A000F405	abcephi	
VR2A33	265P151010	VARISTOR - AVF16C225A000F405	dgi	
VR2A34	265P151010	VARISTOR - AVF16C225A000F405	abcephi	
VR2A34	265P151010	VARISTOR - AVF16C225A000F405	dgi	
VR2A41	265P151010	VARISTOR - AVF16C225A000F405	dgi	
VR2A42	265P151010	VARISTOR - AVF16C225A000F405	dgi	
VR2A43	265P151010	VARISTOR - AVF16C225A000F405	dgi	
VR2A44	265P151010	VARISTOR - AVF16C225A000F405	dgi	
RESISTORS				
Conventional Resistors (By Ref #)				
Ref #	Part #	Part Name & Description	△	[#]
R9001	109P179020	R-CEMT-PLT - 1.8 OHM-J	△	
R9003	109P291010	R-CEMENT-WIRE - RGB5PS-47-OHM J	△	
R9004	109P212090	R-SURGE - 1/2W 4.7M-J	△	
R9005	103P145030	R-CARBON - 1/2W 220K-J		
R9007	103C188020	R-METAL - 2W 2.2-J		
R9019	103P145000	R-CARBON - 1/2W 120K-J		
R9020	103P145000	R-CARBON - 1/2W 120K-J		
R9021	103C187070	R-METAL - 2W 0.56-J		
R9022	103C187070	R-METAL - 2W 0.56-J		
R9025	103P142060	R-CARBON - 1/2W 1.2K-J		
R9028	109D151060	R-CARBON - 1/4W 68-J		
R9030	109D154010	R-CARBON - 1/4W 270-J		
R9036	103C184000	R-METAL - 2W 18K-J		
R9042	103C184000	R-METAL - 2W 18K-J		
R9060	103P145030	R-CARBON - 1/2W 220K-J		
R9075	103P143010	R-CARBON - 1/2W 3.3K-J		
R9082	103C390030	R-METAL-P - 3W 15-J		
R9083	103P145060	R-CARBON - 1/2W 390K-J		
R9085	103P145030	R-CARBON - 1/2W 220K-J		

Ref #	Part #	Part Name & Description	△	[#]
RESISTORS				
CHIP Type Resistors (Listed by Value)				
Part No.	Value	Part No.	Value	
103P408040	1/10W 2.2-J	103P502040	1/16W 820-J	
103P508040	1/16W 2.2-J	103P492050	1/16W 1K-F	
103P408060	1/10W 3.3-J	103P502050	1/16W 1K-J	
103P500010	1/16W 10-J	103P492070	1/16W 1.2K-F	
103P400010	1/10W 10-J	103P502060	1/16W 1.2K-J	
103P400050	1/10W 22-J	103P502070	1/16W 1.5K-J	
103P500050	1/16W 22-J	103P493030	1/16W 2.2K-F	
103P500070	1/16W 33-J	103P502090	1/16W 2.2K-J	
103P500090	1/16W 47-J	103P493050	1/16W 2.7K-F	
103P501000	1/16W 56-J	103P503000	1/16W 2.7K-J	
103P794050	1/16W 68-F	103P493070	1/16W 3.3K-F	
103P501010	1/16W 68-J	103P503010	1/16W 3.3K-J	
103P991020	1/16W 68-JX4	103P493090	1/16W 3.9K-F	
103P509090	1/16W 75-J	103P494010	1/16W 4.7K-F	
103P401030	1/10W 100-J	103P503030	1/16W 4.7K-J	
103P501030	1/16W 100-J	103P503040	1/16W 5.6K-J	
103P490030	1/16W 120-F	103P494080	1/16W 9.1K-F	
103P501040	1/16W 120-J	103P494090	1/16W 10K-F	
103P501050	1/16W 150-J	103P503070	1/16W 10K-J	
103P490070	1/16W 180-F	103P503080	1/16W 12K-J	
103P501060	1/16W 180-J	103P495020	1/16W 13K-F	
103P401070	1/10W 220-J	103P495050	1/16W 18K-F	
103P490090	1/16W 220-F	103P404000	1/8W 18K-J	
103P501070	1/16W 220-J	103P990050	1/16W 22-JX4	
103P491000	1/16W 240-F	103P504010	1/16W 22K-J	
103P491010	1/16W 270-F	103P495080	1/16W 24K-F	
103P501080	1/16W 270-J	103P504030	1/16W 33K-J	
103P491020	1/16W 300-F	103P504040	1/16W 39K-J	
103P501090	1/16W 330-J	103P496050	1/16W 47K-F	
103P491050	1/16W 390-F	103P504050	1/16W 47K-J	
103P502000	1/16W 390-J	103P504060	1/16W 56K-J	
103P491060	1/16W 430-F	103P504090	1/16W 100K-J	
103P491070	1/16W 470-F	103P505000	1/16W 120K-J	
103P502010	1/16W 470-J	103P505030	1/16W 220K-J	
103P491090	1/16W 560-F	103P505040	1/16W 270K-J	
103P502020	1/16W 560-J	103P506010	1/16W 1M-J	
103P400050	1/10W 22-J			

**MODELS: WD-60C9 / WD-65C9 / WD-73C9 / WD-60737 / WD-65737 / WD-73737 / WD-82737
WD-65837 / WD-73837 / WD-82837**

[#] Model Legend: (a) WD-60737, (b) WD-60C9, (c) WD-65737, (d) WD-65837, (e) WD-65C9,
(f) WD-73737, (g) WD-73837, (h) WD-73C9, (i) WD-82737, (j) WD-82837

Ref #	Part #	Part Name & Description	△	[#]
CAPACITORS AND TRIMMERS				
Conventional Capacitors (By Ref #)				
Ref #	Part #	Part Name & Description		
C3A23	181P354090	C-ELEC - 35V 470M-M		
C3A24	181P354090	C-ELEC - 35V 470M-M		
C7AA9	189P252020	C-ELE-DBL-LAYER - EECS0HD224V		
C9000	189P213020	C-M-POLY - AC250/275V 0.47M-M	△	
C9001	189P213020	C-M-POLY - AC250/275V 0.47M-M	△	
C9002	189P213020	C-M-POLY - AC250/275V 0.47M-M	△	
C9004	189P217070	C-CER - AC250V E1000P-M	△	
C9005	189P217070	C-CER - AC250V E1000P-M	△	
C9006	189P217090	C-CER - AC250V E2200P-M	△	
C9007	189P217090	C-CER - AC250V E2200P-M	△	
C9008	189P217070	C-CER - AC250V E1000P-M	△	
C9013	181P189090	C-ELEC - 200V 100M-M 105C		
C9014	142P010090	C-CER - B500V 470P-K		
C9015	181P732040	C-ELEC - 10V 3300M-M 105C		
C9016	181P731090	C-ELEC - 10V 470M-M 105C LOWR		
C9017	185D122040	C-ELEC - H200V 820M-M	△	
C9018	185D122040	C-ELEC - H200V 820M-M	△	
C9019	154P400030	C-CER - B1KV 470P-K		
C9021	181P555080	C-ELEC - 50V 10M-M		
C9030	154P400050	C-CER - B1KV 1000P-K		
C9031	142P010090	C-CER - B500V 470P-K		
C9035	181P734000	C-ELEC - 16V 2200M-M 105C		
C9036	181P734000	C-ELEC - 16V 2200M-M 105C		
C9039	181P555000	C-ELEC - 35V 2200M-M		
C9046	142P010090	C-CER - B500V 470P-K		
C9047	181P555030	C-ELEC - 50V 0.47M		
C9070	189P258010	C-PLSTIC-PP - 630V-3300P-J		
C9072	181P555090	C-ELEC - 50V 22M-M		
C9073	189P280010	C-M-PP - 7T2J333J-SM		
C9086	181P732040	C-ELEC - 10V 3300M-M 105C		
C9A06	181P731090	C-ELEC - 10V 470M-M 105C LOWR		
C9A26	189P256030	C-ALUM - 16V 100M-M UUD1C101MCL1GS		
C9A34	189P256030	C-ALUM - 16V 100M-M UUD1C101MCL1GS		
C9A52	189P256030	C-ALUM - 16V 100M-M UUD1C101MCL1GS		
SWITCHES				
S8000	432P109010	SW-KEY BOARD - KSHS611BT		dgjj
S8002	432P109010	SW-KEY BOARD - KSHS611BT		
S8003	432P109010	SW-KEY BOARD - KSHS611BT		
S8004	432P109010	SW-KEY BOARD - KSHS611BT		
S8005	432P109010	SW-KEY BOARD - KSHS611BT		
S8006	432P109010	SW-KEY BOARD - KSHS611BT		
S8200	432P109010	SW-KEY BOARD - KSHS611BT		abcefh

Ref #	Part #	Part Name & Description	△	[#]
CAPACITORS				
CHIP Type Capacitors (Listed by Value)				
Part No.	Value	Part No.	Value	
154P340060	CK50V 5P-C	141P142010	B50V 0.01M-K	
154P341010	CH50V 10P-C	141P142090	B25V 0.047M-K	
154P341030	CH50V 12P-J	141P144020	F25V 0.1M-Z	
154P341050	CH50V 15P-J	141P143030	B16V 0.1M-K	
154P341090	CH50V 22P-J	141P144030	F25V0.22M-ZCK1608	
154P342030	CH50V 33P-J	141P146050	B16V 0.33M-K	
154P353060	SL50V 100P-J	141P146080	B10V 0.47M-K	
154P343050	CH50V 100P-J	141P148000	B25V 1M-K	
154P354040	SL50V 220P-J	141P144060	B16V 1M-Z	
154P344030	CH50V 220P-J	141P147020	B10/6.3V 1M-K	
141P140030	B50V 330P-K	141P147040	B6.3V 2.2M-K	
141P140050	B50V 470P-K	141P147060	B6.3V 4.7M-K	
154P345010	CH50V 470P-J	189P253010	B6.3V 10M-M	
141P140090	B50V 1000P-K	189P253020	B16V 10M-M	
141P141030	B50V 2200P-K	181P826050	50V 10M-M 105C	
141P141040	B50V 2700P-K	181P820010	6.3V 22M-M 105C	
141P141050	B50V 3300P-K	181P820030	6.3V 47M-M 105C	
141P141060	B50V 3900P-K	181P822070	16V 100M-M 105C	
141P141070	B50V 4700P-K	181P828010	4V 220M-M 105C	
141P142000	B50V 8200P-K	141P242010	B50V 0.1M-K	
141P140060	B50V 560P-K	154P342010	CH50V 27P-J	
141P141090	B50V 6800P-K	154P344010	CH50V 180P-J	
MISCELLANEOUS				
246C578040	CABLE-DVI			
246C627010	AC POWER CORD			
299P321010	FAN-SCIROCCO - BG0703-B042-00L-T3			
299P335010	COOLING-FAN - LAMP/BALLAST			
299P339010	FAN-DMD			
299P337010	THERMAL SENSOR			
411D044020	CORE-FERRITE - ZCAT2032-0930			
411D062010	CORE-FERRITE - ZCAT1518-0730			
434P004010	SWITCH-INTERLOCK			
480P084020	SPEAKER - 8 Ohms 10 watts			
491P240010	PROJECTION LENS			
572C013010	SPRING-DOOR			abcefh
622C489070	SPACER-SPEAKER			abcefh
622D484010	HOLDER-LED			
623D418010	HOLDER-FAN			
642B179010	DUCT-TOP			
642B180010	DUCT-BOTTOM			
642C431010	CATCH			dgjj
642C432010	STRIKER			dgjj
642C438010	DAMPER-SPEAKER			
716C044010	BADGE-BRAND			abcefh
740B239020	BUTTON POWER			abcefh
740B240010	BUTTON-POWER			dgjj
752C353010	TERMINAL-SIDE-JACK			abcefh
752C353020	TERMINAL-SIDE-JACK			dgj
761A355040	COVER BACK			abcde
761A359040	COVER-BACK			fg hij
761B471010	COVER-PORHOLE			
761B478020	COVER-LAMP			
761B505020	DOOR-FRONT			ac

**MODELS: WD-60C9 / WD-65C9 / WD-73C9 / WD-60737 / WD-65737 / WD-73737 / WD-82737
WD-65837 / WD-73837 / WD-82837**

[#] Model Legend: (a) WD-60737, (b) WD-60C9, (c) WD-65737, (d) WD-65837, (e) WD-65C9,
(f) WD-73737, (g) WD-73837, (h) WD-73C9, (i) WD-82737, (j) WD-82837

Ref #	Part #	Part Name & Description	△	[#]
	761B505030	DOOR-FRONT		be
	761B506020	DOOR-FRONT		f
	761B506030	DOOR-FRONT		h
	761B511010	DOME-SPEAKER-R	abcefh	
	761B511020	DOME-SPEAKER-L	abcefh	
	761B541010	SPEAKER-DOME	dgij	
	761B550010	SBL-HOLDER	dg	
	761C837010	LED CHIP	dgij	
	761C842010	SBL-LENS	dgij	
	761D999020	LED-CHIP	abcefh	
	771D127010	PAD-BOTTOM		ij
	771D127030	PAD-BOTTOM	abce	
	771D139010	PAD-BOTTOM	dfgh	
	771D139020	PAD-MIRROR-HOLDER	fgh	
	915B403001	LAMP-CARTRIDGE (V41)	△	
	938P137010	COLOR-WHEEL		
	938P088010	DB-MODULE	dgj	
	938P158010	OPTICAL-ENGINE	ab	
	938P158020	OPTICAL-ENGINE	ce	
	938P158030	OPTICAL-ENGINE	fh	
	938P158040	OPTICAL-ENGINE	i	
	955B378003	OPTICAL-ENGINE	d	
	955B378004	OPTICAL-ENGINE	g	
	955B378005	OPTICAL-ENGINE	j	
3D	440C474010	PIN-JACK-MINI-DIN-3P		
AG9000	299P340010	SURGE-SUPPRESSOR DE37-452M-A21F	△	
F9000	283D161010	FUSE - 125V 10A	△	
F9001	283P144080	FUSE - 125V 5A Type 20N Skygate Co. Ltd.	△	
F9002	283P144080	FUSE - 125V 5A Type 20N Skygate Co. Ltd.	△	
F9003	283P144080	FUSE - 125V 5A Type 20N Skygate Co. Ltd.	△	
F9A01	283P171090	FUSE-CHIP - KAB2402632NA29010	△	
		24V 6.3A Type KAB Matsuo Electric Co. Ltd.		
J6C00	452C564010	DVI CONNECTOR		
K9010	287P111060	RELAY-POWER - LKT1AF-5V	△	
K9011	287P111060	RELAY-POWER - LKT1AF-5V	△	
P7E01	451C268010	JACK-IR BLASTER 1P	dgj	
P9B01	440C457040	PIN-JACK-BOARD-9P		
P9B02	440C458020	PIN-JACK-BOARD-6P		
P9B03	440C475010	PIN-JACK-BOARD-3P		
P9B04	440C476010	PIN-JACK-BOARD-2P		
PC9010	268P125010	PHOTO-COUPLER - FOD617C	△	
PC9020	268P125010	PHOTO-COUPLER - FOD617C	△	
TU1A01	295P571010	NTSC/ATSC TUNER - 115U4020AM	△	
X3A01	285P485030	QTZ-CRYST - SMD-49 24.576MHZ		
X4A01	285P494010	QTZ-CRYST - HC-49/U 54MHZ		
X4L01	285P481070	QTZ-CRYST - SMD-49 7.3728MHZ		
X4L02	285P485030	QTZ-CRYST - SMD-49 24.576MHZ		
X7A01	285P403020	QTZ-CRYST - DMX-S26S 32.768KHz		
X7A02	285P481090	QTZ-CRYST - SMD-49 20MHZ		
Z8300	938P078010	UNIT-PREAMP - ROM-V3132SY		

Ref #	Part #	Part Name & Description	△	[#]
PRINTED CIRCUIT BOARDS				
	934D057001	ASSY-PWB-LED		abcefh
	934C328001	ASSY-PWB-MAIN		abcephi
	934C328002	ASSY-PWB-MAIN		dgj
	934C329001	ASSY-PWB-POWER		
	934C331001	ASSY-PWB-SBL		dgj
	934D058001	ASSY-PWB-PREAMP		abcephi
	934D058002	ASSY-PWB-PREAMP		dgj
	934D059001	ASSY-PWB-SW-LAMP		
	934D060001	ASSY-PWB-CONTROL		abcefh
	934D060002	ASSY-PWB-CONTROL		dgij
	934D062001	ASSY-PWB-RS232		dgj
	938P127010	ASSY-BALLAST-PWB	△	
COSMETIC PARTS				
	760C825010	INLAY-CONTROL		abce
	760C831010	INLAY CONTROL		fh
	761A423010	COVER-FRONT		i
	761A423020	COVER-FRONT		j
	761A425010	PEDESTAL		ij
	761B544010	65-ORNAMENT L&R		d
	761B546010	ORNAMENT-C		dgij
	761B550020	SBL-HOLDER		j
	761B551010	73-ORNAMENT L&R		g
	761B552010	82-ORNAMENT L&R		ij
	761B555010	ORNAMENT L/R		a
	761B555020	ORNAMENT RIGHT		a
	761B555030	ORNAMENT LEFT		b
	761B555040	ORNAMENT RIGHT		b
	761B556010	ORNAMENT LEFT		c
	761B556020	ORNAMENT RIGHT		c
	761B556030	ORNAMENT LEFT		e
	761B556040	ORNAMENT RIGHT		e
	761B557010	ORNAMENT LEFT		f
	761B557020	ORNAMENT RIGHT		f
	761B557030	ORNAMENT LEFT		h
	761B557040	ORNAMENT RIGHT		h
	775B170010	NAME-PLATE		a
	775B170020	NAME-PLATE		c
	775B170030	NAME-PLATE		f
	775B170040	NAME-PLATE		i
	775B170050	NAME-PLATE		d
	775B170060	NAME-PLATE		g
	775B170070	NAME-PLATE		j
	775B170080	NAME-PLATE		b
	775B170090	NAME-PLATE		e
	775B171010	NAME-PLATE		h

**MODELS: WD-60C9 / WD-65C9 / WD-73C9 / WD-60737 / WD-65737 / WD-73737 / WD-82737
WD-65837 / WD-73837 / WD-82837**

[#] Model Legend: (a) WD-60737, (b) WD-60C9, (c) WD-65737, (d) WD-65837, (e) WD-65C9,
(f) WD-73737, (g) WD-73837, (h) WD-73C9, (i) WD-82737, (j) WD-82837

Ref #	Part #	Part Name & Description	△	[#]
MIRROR KITS				
	KIT-MIR V41 60"	60" MIRROR KIT		ab
	KIT-MIR V41 65"	65" MIRROR KIT		cde
	KIT-MIR V41 73"	73" MIRROR KIT		fhg
	KIT-MIR V41 82"	82" MIRROR KIT		ij
ACCESSORIES				
	290P175010	REMOTE-CONTROL - V41		
	774P001010	CLOTH-SOFT		j
	I/B WD60737	BASIC INSTRUCTION GUIDE		
	I/Q V41	QUICK-CONNECT-GUIDE		

Ref #	Part #	Part Name & Description	△	[#]
-------	--------	-------------------------	---	-----

**MODELS: WD-60C9 / WD-65C9 / WD-73C9 / WD-60737 / WD-65737 / WD-73737 / WD-82737
WD-65837 / WD-73837 / WD-82837**

[#] Model Legend: (a) WD-60737, (b) WD-60C9, (c) WD-65737, (d) WD-65837, (e) WD-65C9,
(f) WD-73737, (g) WD-73837, (h) WD-73C9, (i) WD-82737, (j) WD-82837

SCREEN PARTS - 60", 65" & 73" MODELS

Ref#	Part#	Description	Model
(0)	LENS-TAPE	TAPE-LENS	
(1)	491P217040	SCREEN-LENTICULAR	ab
(1)	491P217050	SCREEN-LENTICULAR	cde
(1)	491P217060	SCREEN-LENTICULAR	fgh
(2)	491P218010	LENS-FRESNEL	ab
(2)	491P218020	LENS-FRESNEL	cde
(2)	491P218030	LENS-FRESNEL	fgh
(3)	593B341010	HOLDER-SCREEN T	cde
(3)	593B350010	HOLDER-SCREEN-T	ab
(3)	593B371010	HOLDER-SCREEN-T	fgh
(4)	593B342010	HOLDER-SCREEN B	cde
(4)	593B359010	HOLDER-SCREEN-B	ab
(4)	593B372010	HOLDER-SCREEN-B	fgh
(5)	621B196010	HOLDER-SCREEN S	ab
(5)	621B196020	HOLDER-SCREEN S	cde
(5)	621B207010	HOLDER-SCREEN-S	fgh

Ref#	Part#	Description	Model
(6)	622C487080	SPACER-SCREEN CORNERS	fgh
(7)	622C489060	SPACER-SCREEN-TOP	ab
(7)	622C489080	SPACER-SCREEN-TOP	cdefgh
(8)	622C550080	SPACER-SCREEN-B	cde
(8)	622C550090	SPACER-SCREEN-B	ab
(8)	622C601030	SPACER-SCREEN-B	fgh
(9)	622C608010	SPACER-SCREEN-S	fgh
(10)	621B211010	COVER-HOLDER-T	cde
(10)	621B212010	COVER-HOLDER-T	ab
(10)	621B213010	COVER-HOLDER-T	fgh
(11)	761A382020	BEZEL-FRONT	ce
(11)	761A383020	BEZEL-FRONT	ab
(11)	761A384020	BEZEL-FRONT	fh
(11)	761A422010	BEZEL-FRONT	d
(11)	761A424010	BEZEL-FRONT	g

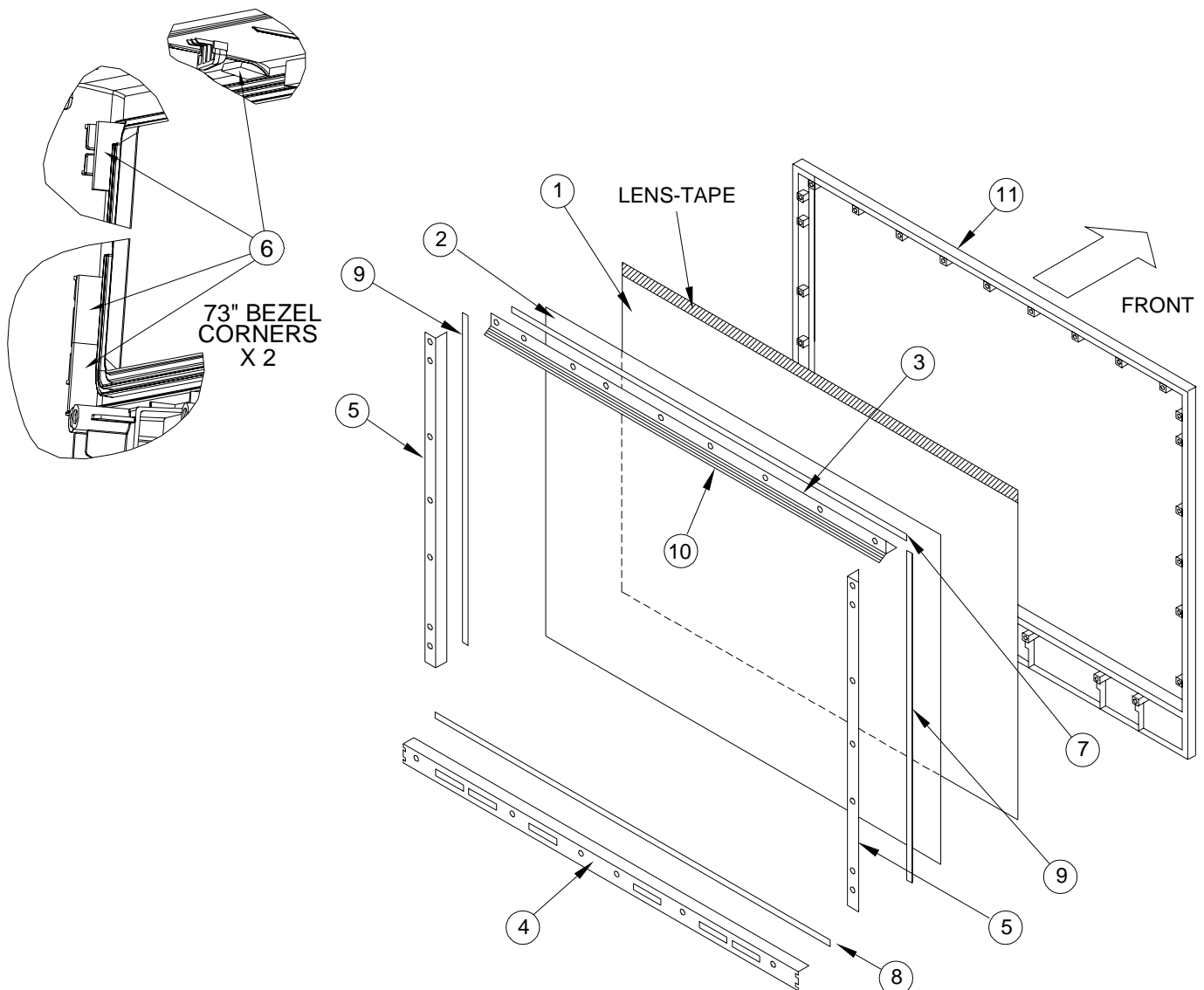

**MODELS: WD-60C9 / WD-65C9 / WD-73C9 / WD-60737 / WD-65737 / WD-73737 / WD-82737
WD-65837 / WD-73837 / WD-82837**

[#] Model Legend: (a) WD-60737, (b) WD-60C9, (c) WD-65737, (d) WD-65837, (e) WD-65C9,
(f) WD-73737, (g) WD-73837, (h) WD-73C9, (i) WD-82737, (j) WD-82837

SCREEN PARTS 82" MODELS

Ref#	Part#	Description	Model
(1)	491P231010	SCREEN-LENTICULAR	ij
(2)	491P232010	LENS-FRESNEL	ij
(3)	711B073010	COVER-HOLDER-T	i
(3)	711B073020	COVER-HOLDER-T	j
(4)	635B135010	CORNER-S-T	ij
(5)	761B538020	CORNER-CAP-TOP-R	i
(5)	761B538040	CORNER-CAP-TOP-R	j
(6)	711B074020	HOLDER-SCREEN-S-R	i
(6)	711B074040	HOLDER-SCREEN-S-R	j
(7)	635B136020	CORNER-B-R	ij
(8)	711B075010	HOLDER-SCREEN-B	ij
(9)	635B136010	CORNER-B-L	ij
(10)	711B074010	HOLDER-SCREEN-S-L	i
(10)	711B074030	HOLDER-SCREEN-S-L	j
(11)	761B538010	CORNER-CAP-TOP-L	i
(11)	761B538030	CORNER-CAP-TOP-L	j
(12)	623D513010	HOLDER-SCREEN-TOP/BOTTOM	ij
(13)	623D513020	HOLDER-SCREEN-SIDES	ij

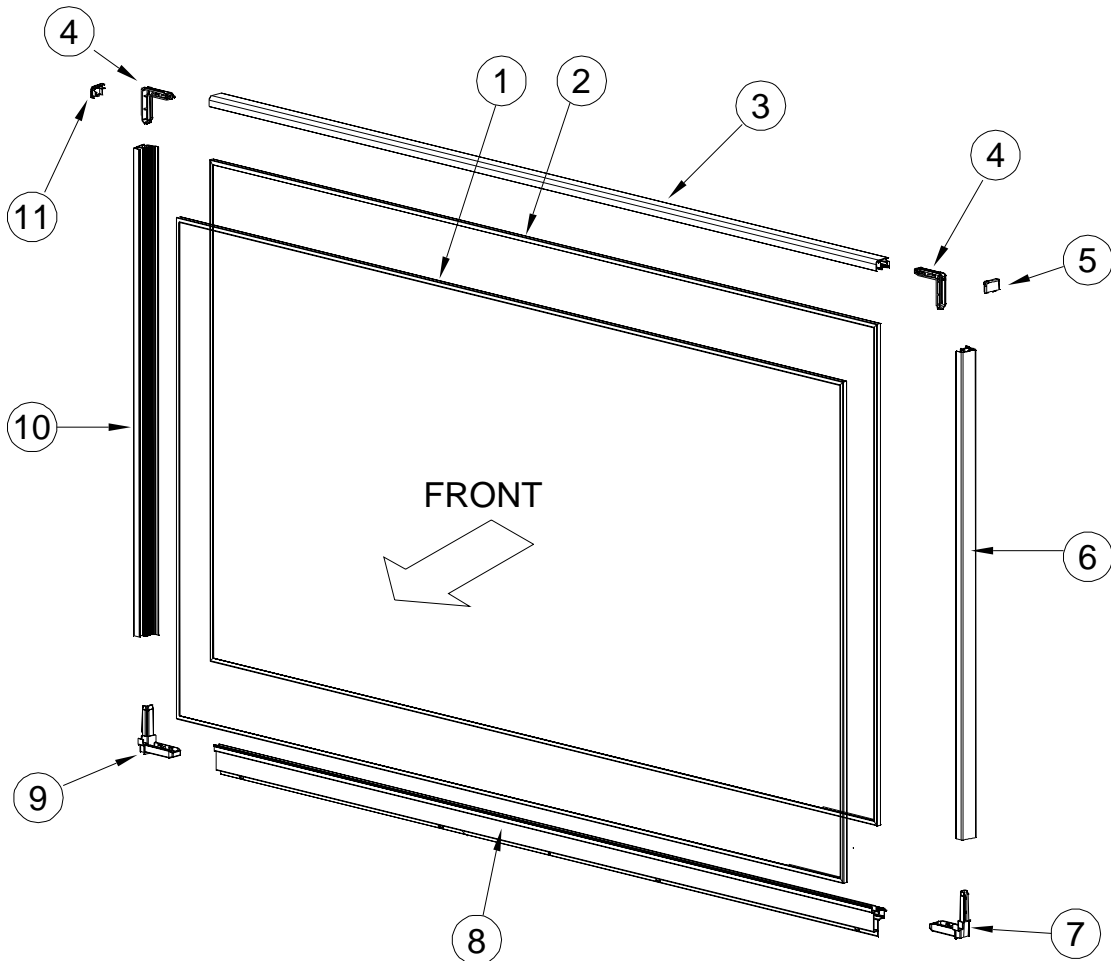
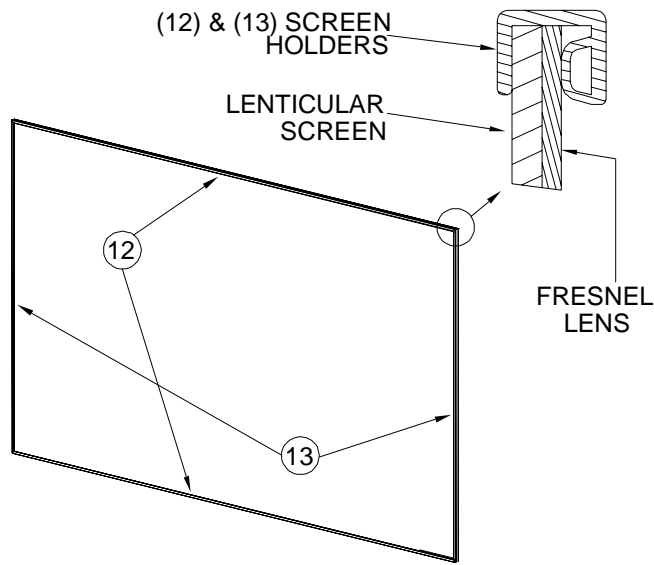

MIRROR KIT PARTS LIST

MODEL	KIT	PART DESCRIPTION	PART #	QTY
WD-60C9 WD-60737	KIT-MIR V41 60"	MIRROR 60 Inch	767D088050	1
		HOLDER-MIRROR-EDGE	623D439050	3
WD-65C9 WD-65737 WD-65837	KIT-MIR V41 65"	MIRROR 65 Inch	767D088070	1
		HOLDER-MIRROR-EDGE	623D439020	3
		STIFFENER, 703mm	601D001030	2
WD-73C9 WD-73737 WD-73837	KIT-MIR V41 73"	MIRROR 73 Inch	767D088080	1
		HOLDER-MIRROR-EDGE	623D439040	3
		HOLDER-MIRROR-EDGE-T	623D439030	1
		STIFFENER, 850mm	601D001050	2
		STIFFENER, 1100mm	601D001040	1
WD-82737 WD-82837	KIT-MIR V41 82"	MIRROR 82 Inch	767D089010	1
		HOLDER-MIRROR-EDGE-T	623D512010	1
		HOLDER-MIRROR-EDGE-B	623D512020	1
		HOLDER-MIRROR-SIDE	623D515010	2

MIRROR PREPARATION

Prepare the mirror for installation by adding HOLDER-MIRROR-EDGE and STIFFENERS to the back of the mirror. The back of the mirror is identified by the date code printed in the lower right corner.

NOTE: No stiffeners are used in the 60 inch or 82 inch models.

STIFFENER INSTALLATION

	Side Stiffener	Top Stiffener
65" Models	40mm from SIDE Edge and 84mm from BOTTOM EDGE	N/A
73" Models	40mm from BOTTOM Edge and 40mm from SIDE EDGE	130mm from TOP Edge

60 Inch Mirror Assembly

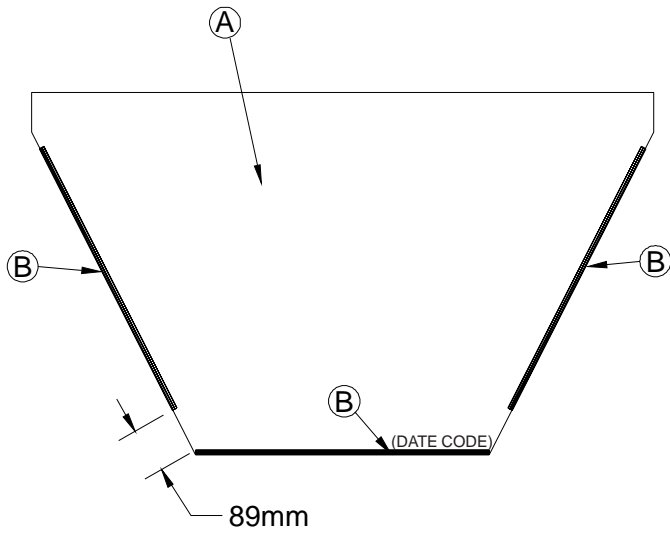

LEGEND

- A) Backside of Mirror (Date Code printed on bottom right side)
- B) HOLDER-MIRROR-EDGE SIDES
- C) STIFFENER-SIDES
- D) HOLDER-MIRROR-EDGE TOP
- E) STIFFENER-TOP
- F) HOLDER-MIRROR-EDGE BOTTOM

65 Inch Mirror Assembly

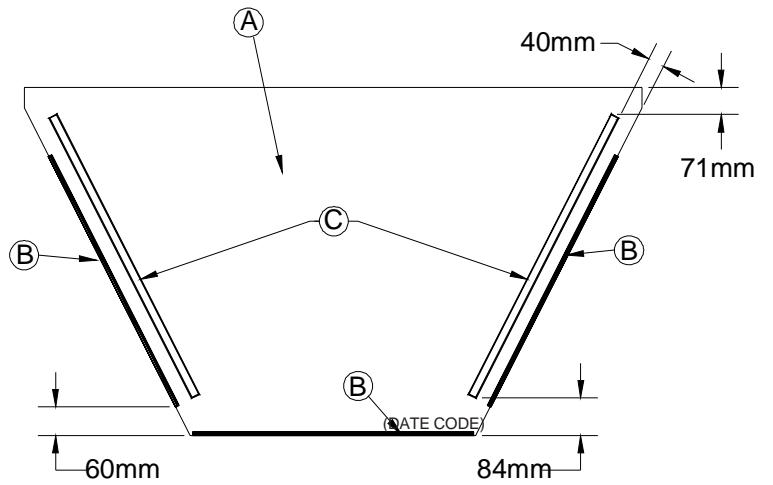

73 Inch Mirror Assembly

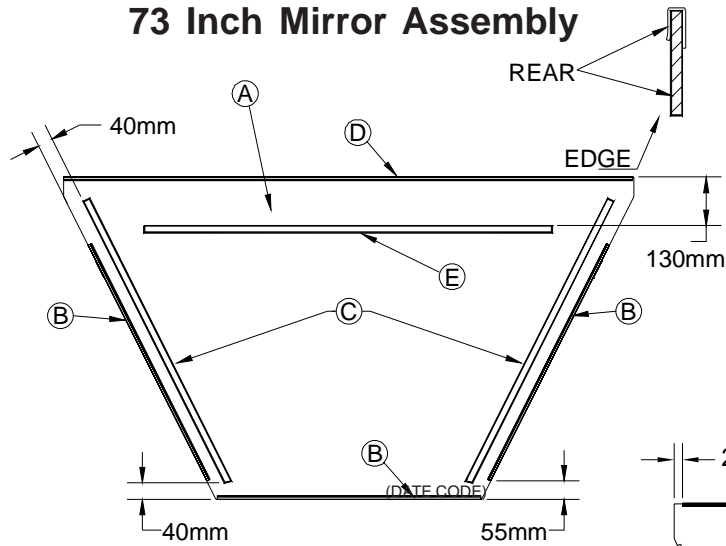

82 Inch Mirror Assembly

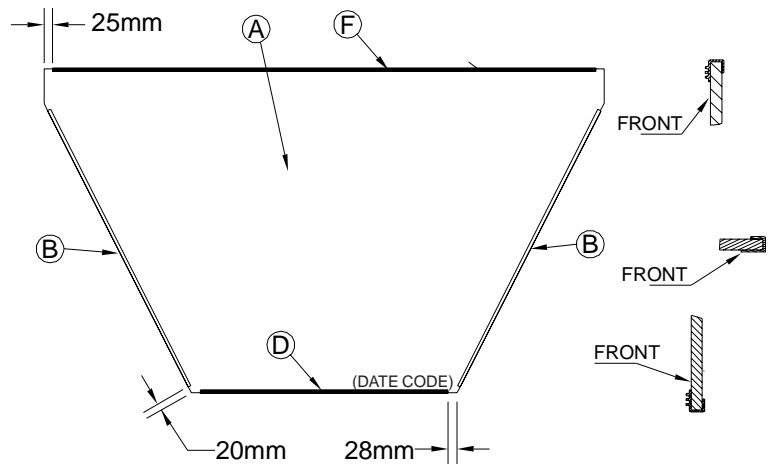

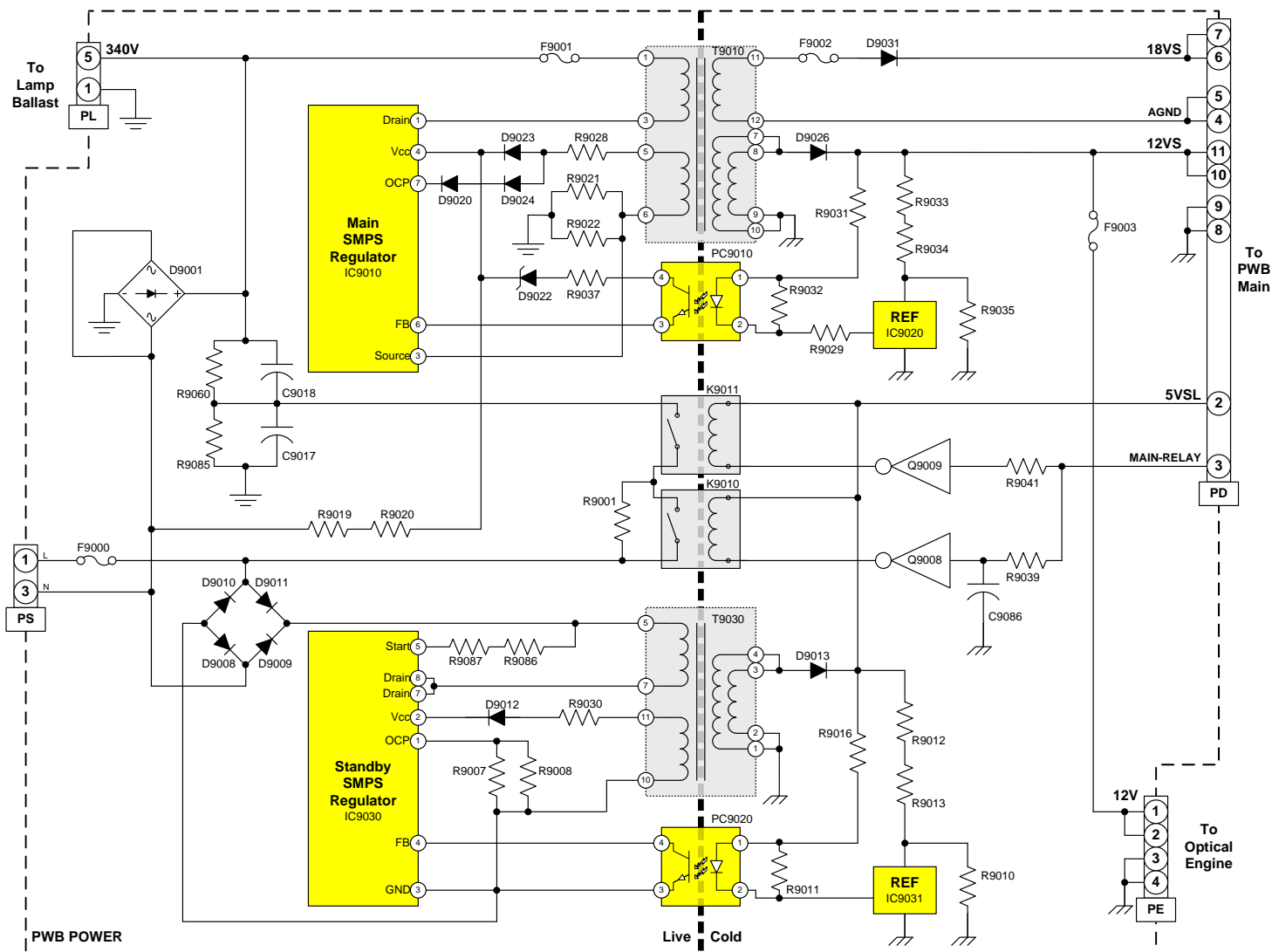

Main Power Supply

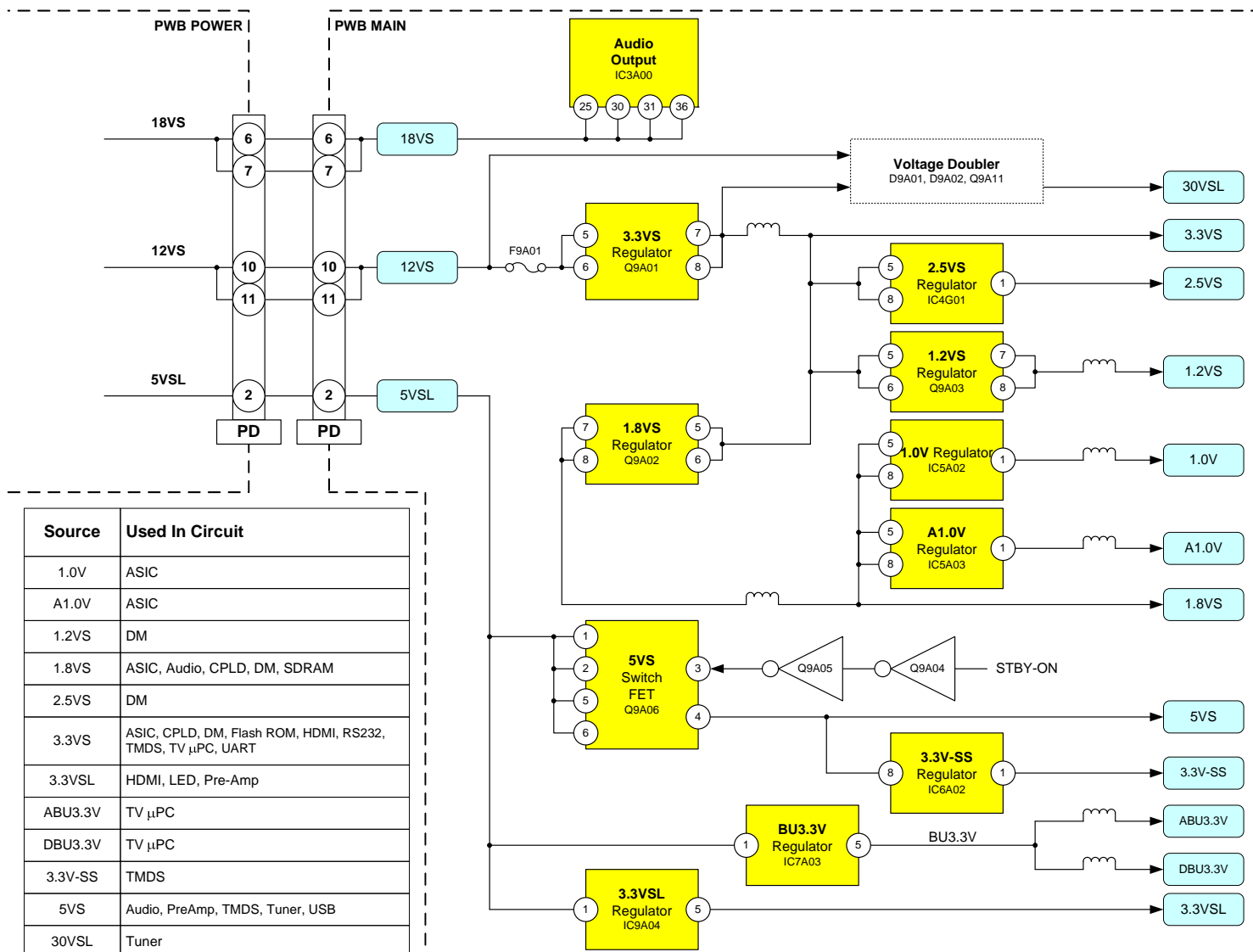

DC-DC Supplies

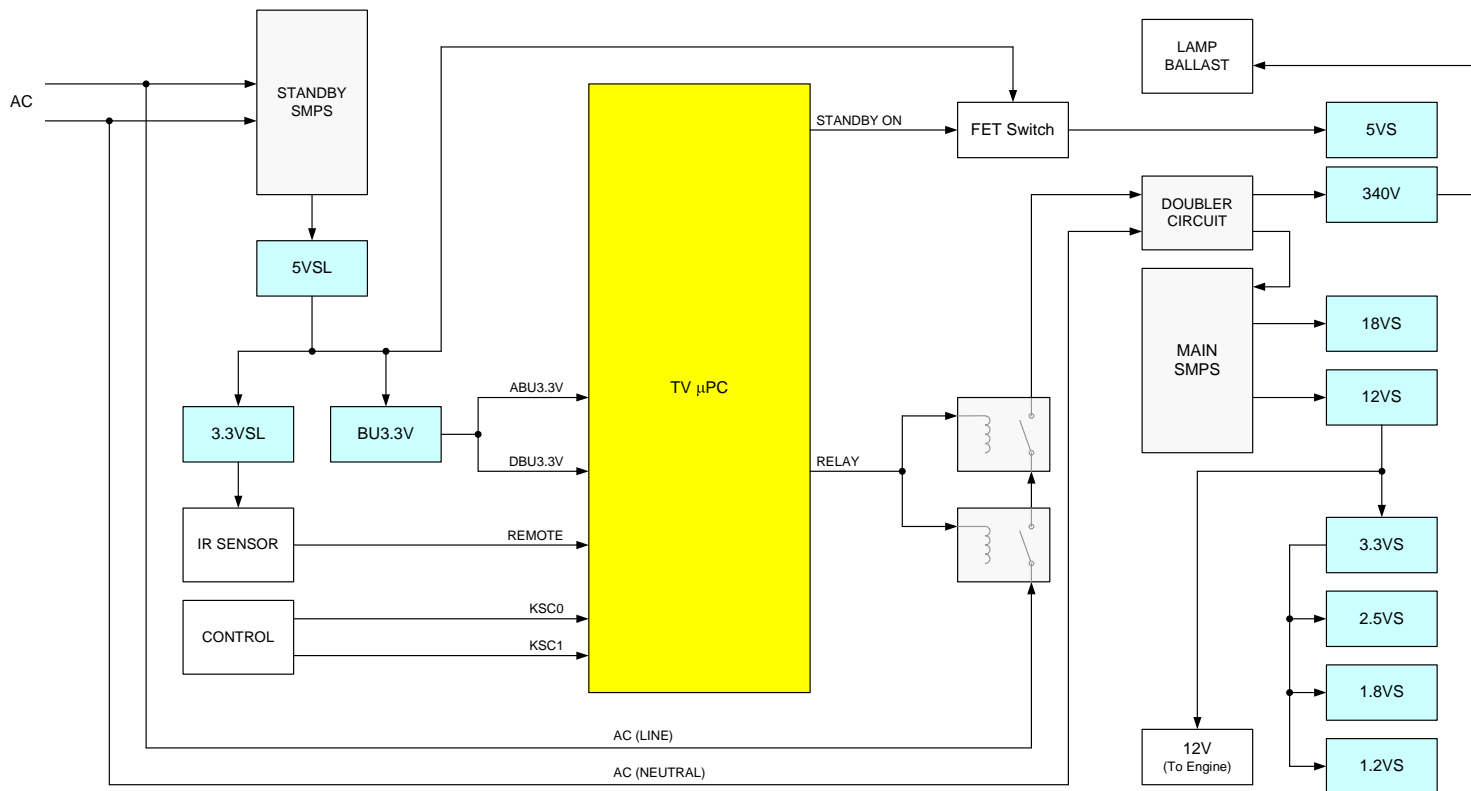

Power Control

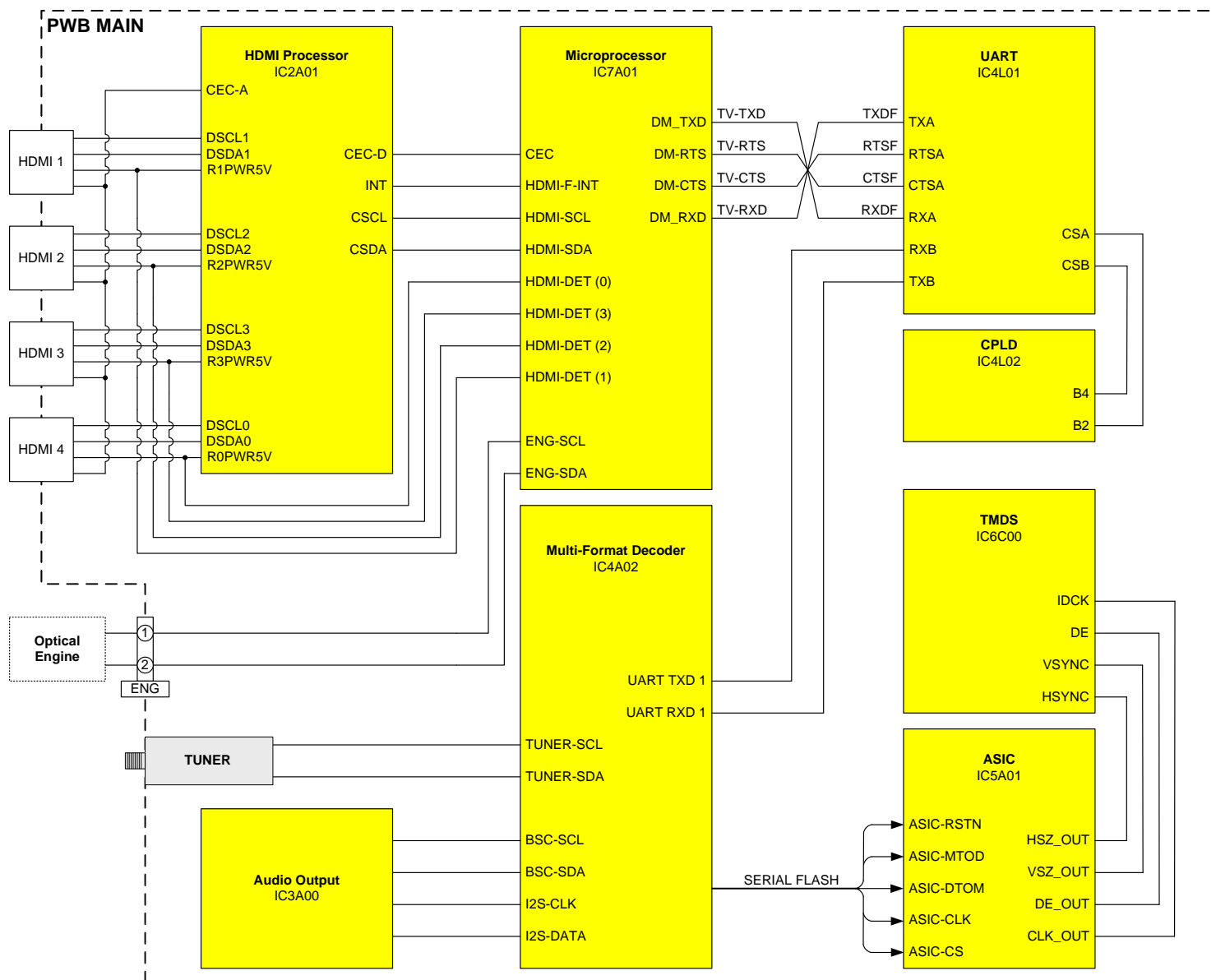

System Control

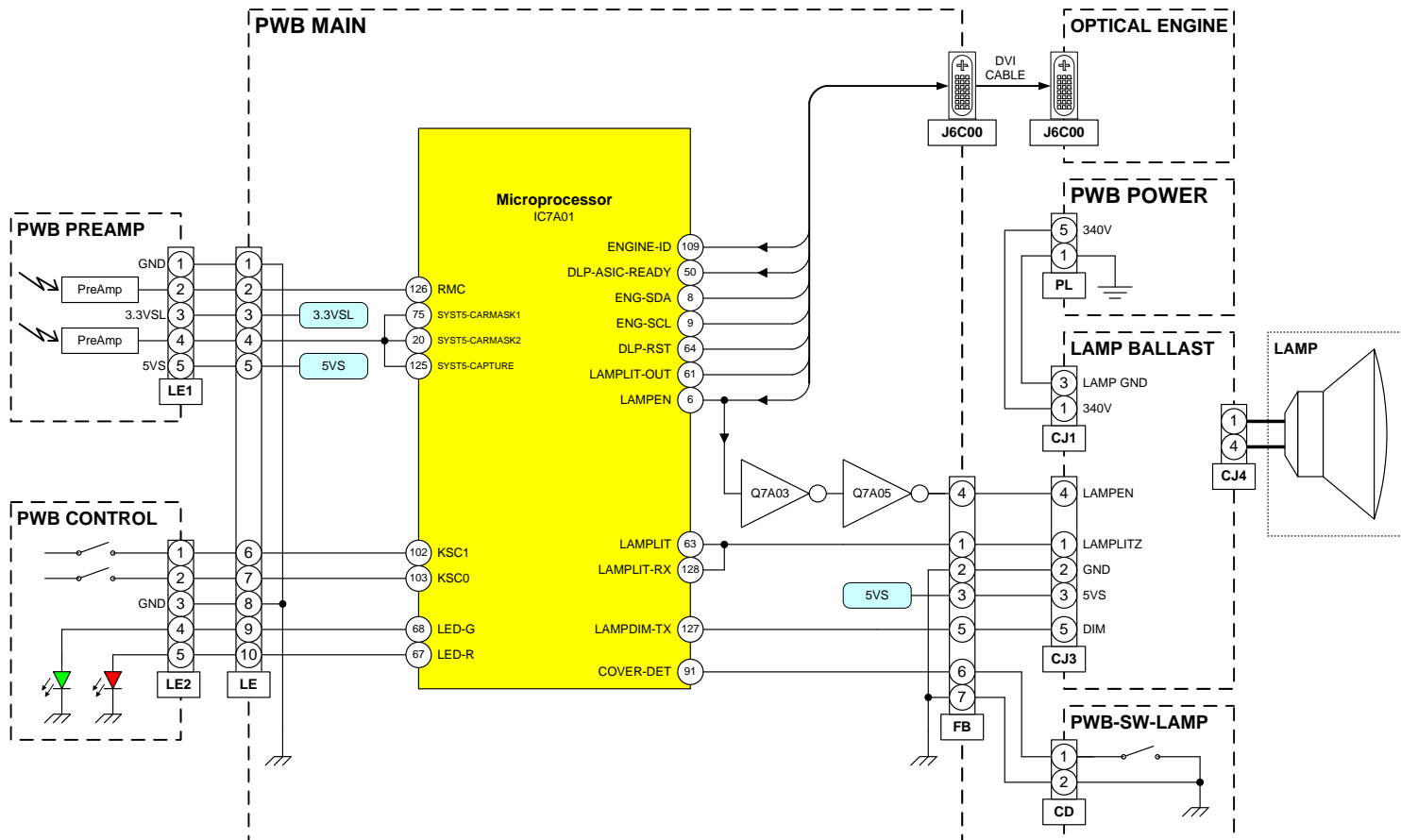

Lamp Control

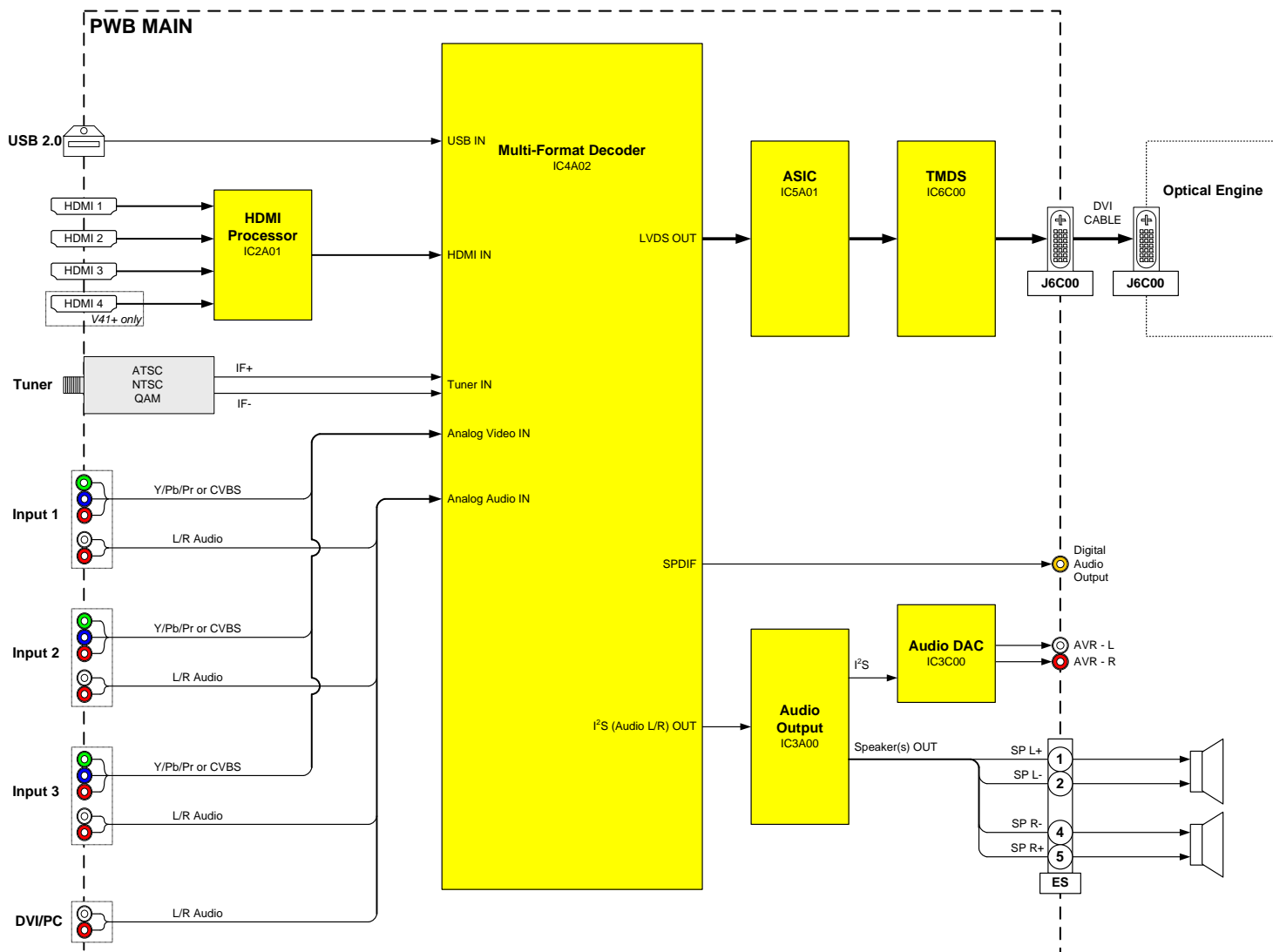

Video/Audio Signal Path

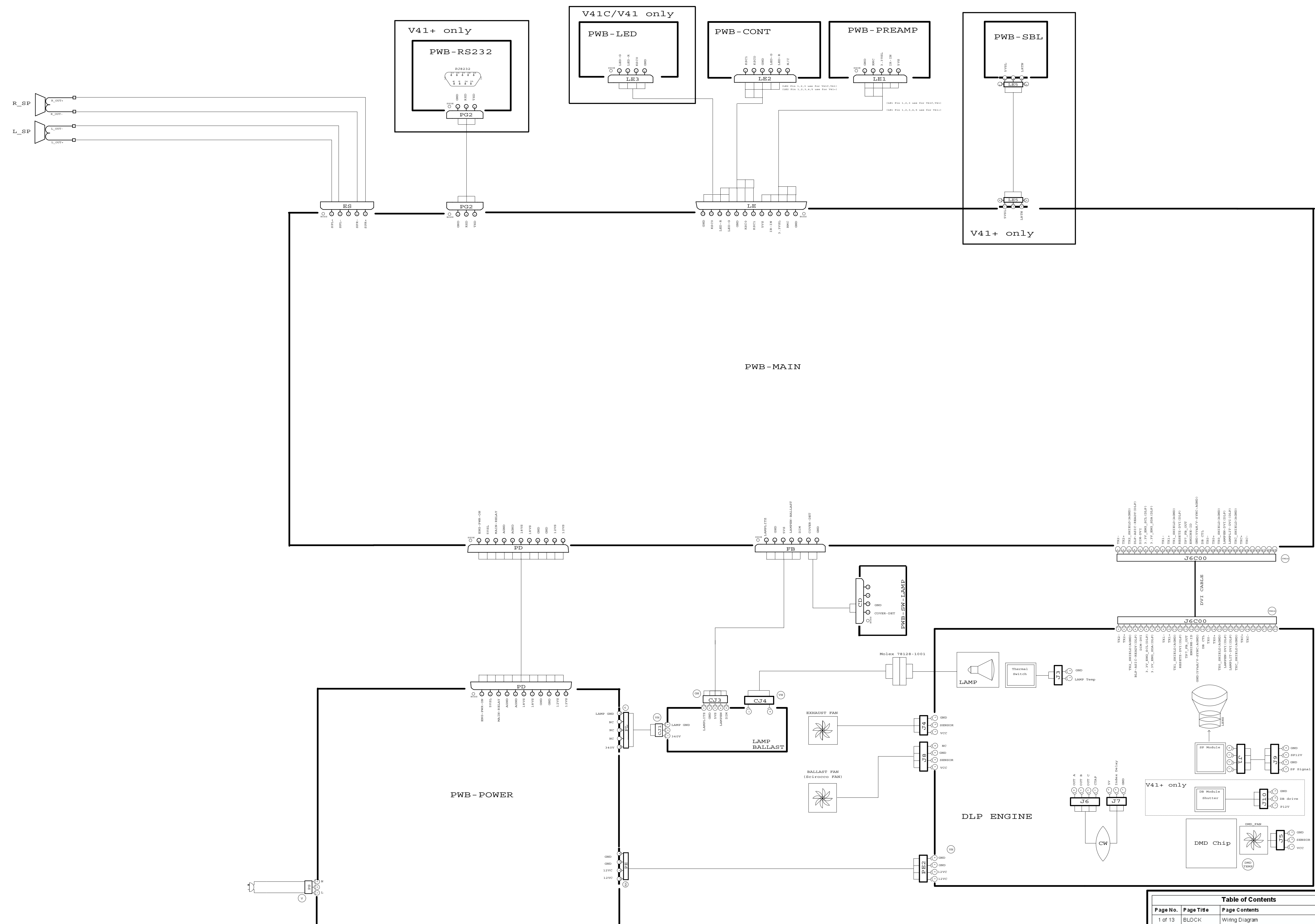

1 of 13 BLOCK

SHADED COMPONENTS HAVE SPECIAL CHARACTERISTICS IMPORTANT TO SAFETY. BEFORE REPLACING ANY OF THESE COMPONENTS, READ CAREFULLY THE PRODUCT SAFETY NOTICE IN THE SERVICE MANUAL. DON'T DEGRADE THE SAFETY OF THE RECEIVER THROUGH IMPROPER SERVICING.

Table of Contents		
Page No.	Page Title	Page Contents
1 of 13	BLOCK	Wiring Diagram
2 of 13	PWB-POWER	Power Supply
3 of 13	MAIN-01	DC-DC / JACK
4 of 13	MAIN-02	TUNER / I/O
5 of 13	MAIN-03	HDMI
6 of 13	MAIN-04	DM-CORE
7 of 13	MAIN-05	DM-MEMORY
8 of 13	MAIN-06	ROM / EBI
9 of 13	MAIN-07	ASIC
10 of 13	MAIN-08	TMDS
11 of 13	MAIN-09	AUDIO
12 of 13	MAIN-10	MICRO
13 of 13	MISC PWBs	Control_LED, Preamp, SW-Lamp, RS232, SBL

Model	Chassis
WD-60C9	V41C
WD-65C9	V41C
WD-73C9	V41C
WD-60737	V41
WD-65737	V41
WD-73737	V41
WD-82737	V41
WD-65837	V41+
WD-73837	V41+
WD-82837	V41+

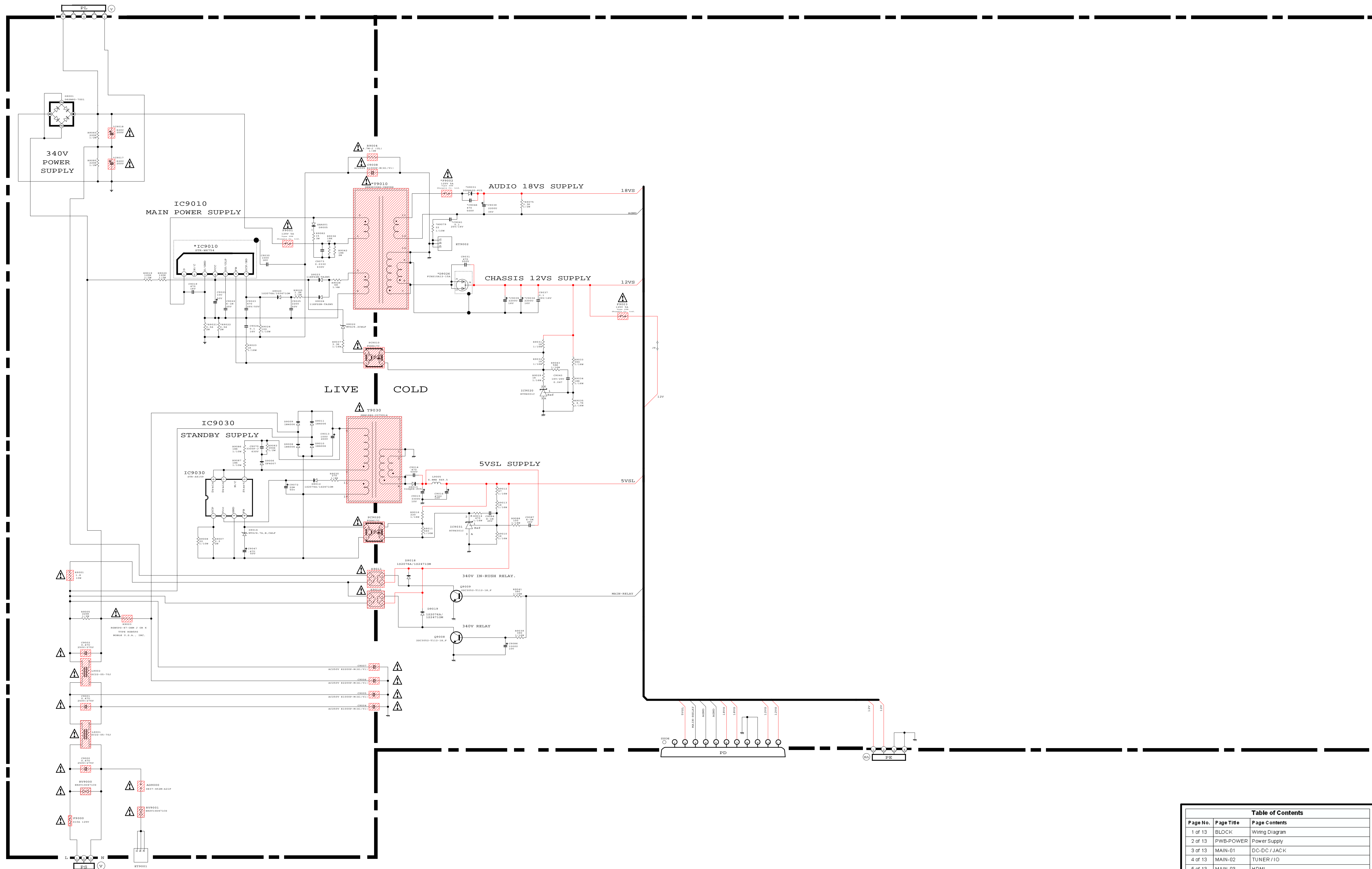
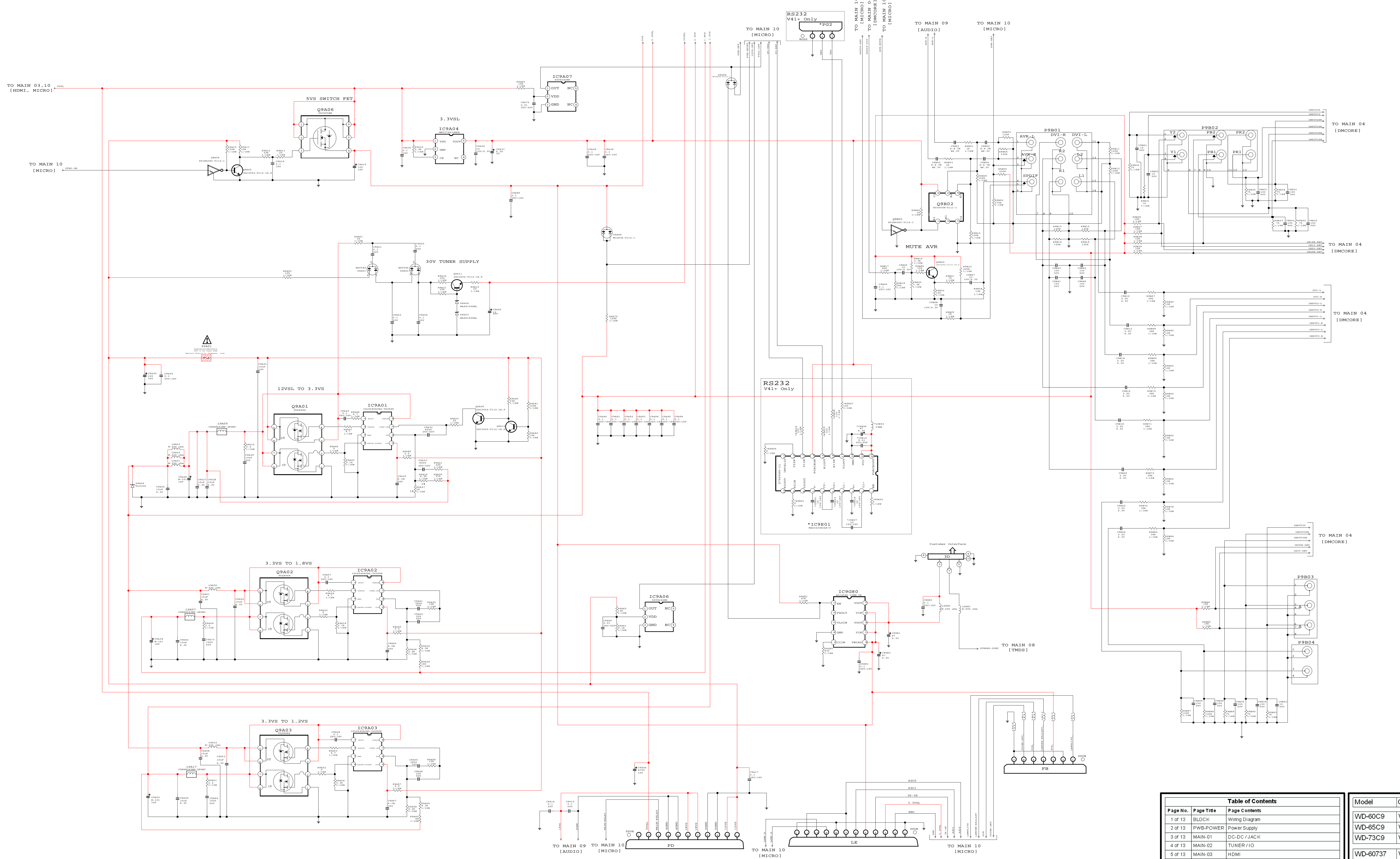

Table of Contents		
Page No.	Page Title	Page Contents
1 of 13	BLOCK	Writing Diagram
2 of 13	PWB-POWER	Power Supply
3 of 13	MAIN-01	DC-DC / JACK
4 of 13	MAIN-02	TUNER / I/O
5 of 13	MAIN-03	HDMI
6 of 13	MAIN-04	DM-CORE
7 of 13	MAIN-05	DM-MEMORY
8 of 13	MAIN-06	ROM / EBI
9 of 13	MAIN-07	ASIC
10 of 13	MAIN-08	TMDS
11 of 13	MAIN-09	AUDIO
12 of 13	MAIN-10	MICRO
13 of 13	MISC PWBs	Control_LED, Preamp, SW-Lamp, RS232, SBL

Model	Chassis
WD-60C9	V41C
WD-65C9	V41C
WD-73C9	V41C
WD-60737	V41
WD-65737	V41
WD-73737	V41
WD-82737	V41
WD-65837	V41+
WD-73837	V41+
WD-82837	V41+



3 of 13 MAIN-01 DC-DC / JACK

SHADED COMPONENTS HAVE SPECIAL CHARACTERISTICS IMPORTANT TO SAFETY. BEFORE REPLACING ANY OF THESE COMPONENTS, READ CAREFULLY THE PRODUCT SAFETY NOTICE IN THE SERVICE MANUAL. DON'T DEGRADE THE SAFETY OF THE RECEIVER THROUGH IMPROPER SERVICING.

Table of Contents		
Page No.	Page Title	Page Contents
1 of 13	BLOCK	Wiring Diagram
2 of 13	PWB-POWER	Power Supply
3 of 13	MAIN-01	DC-DC / JACK
4 of 13	MAIN-02	TUNER / I/O
5 of 13	MAIN-03	HDMI
6 of 13	MAIN-04	DM-CORE
7 of 13	MAIN-05	DM-MEMORY
8 of 13	MAIN-06	ROM / EBI
9 of 13	MAIN-07	ASIC
10 of 13	MAIN-08	TMDS
11 of 13	MAIN-09	AUDIO
12 of 13	MAIN-10	MICRO
13 of 13	MISC PWBS	Control_LED, Preamp, SW-Lamp, RS232, SBL

Model	Chassis
WD-60C9	V41C
WD-65C9	V41C
WD-73C9	V41C
WD-60737	V41
WD-65737	V41
WD-73737	V41
WD-82737	V41
WD-65837	V41+
WD-73837	V41+
WD-82837	V41+

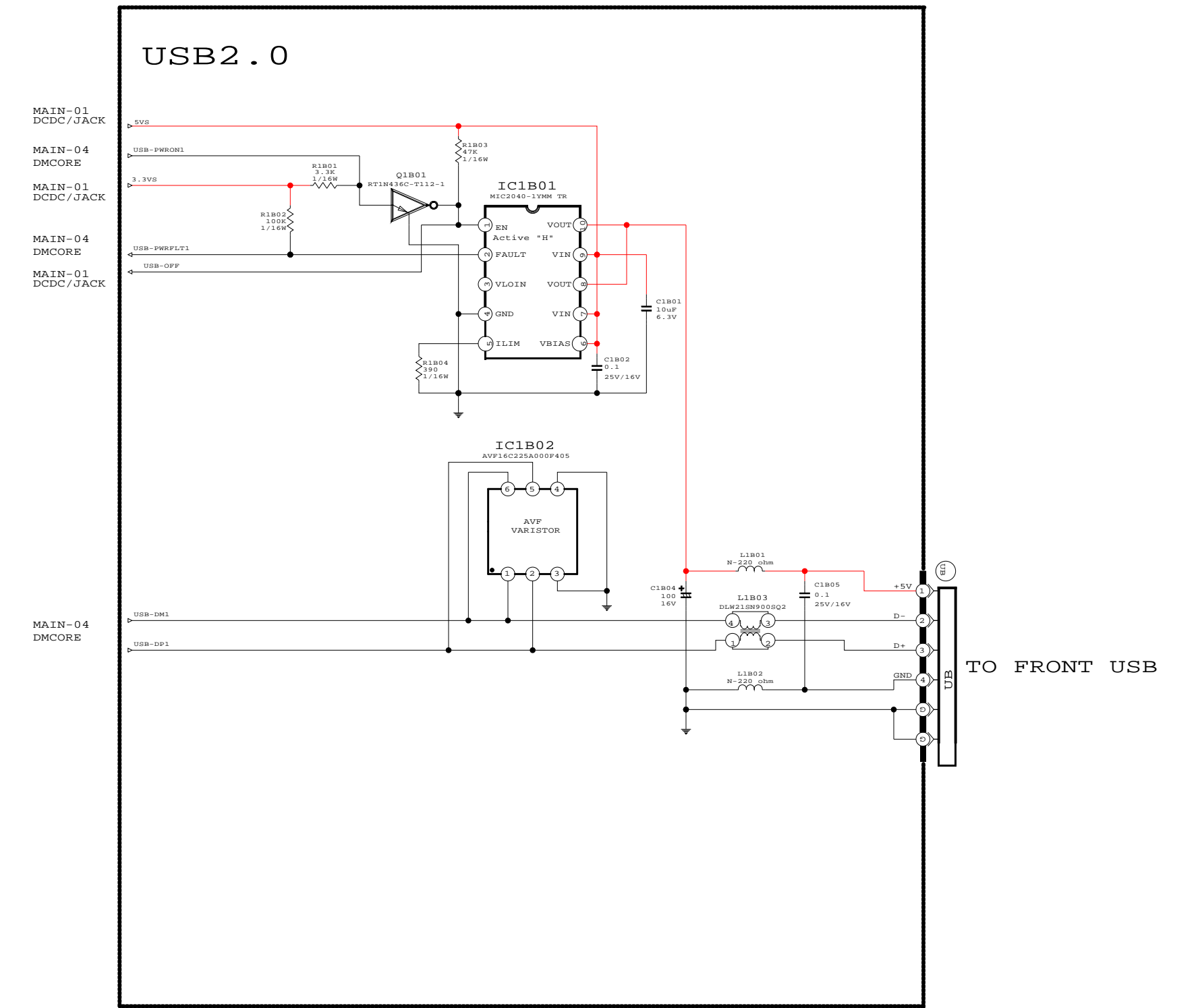
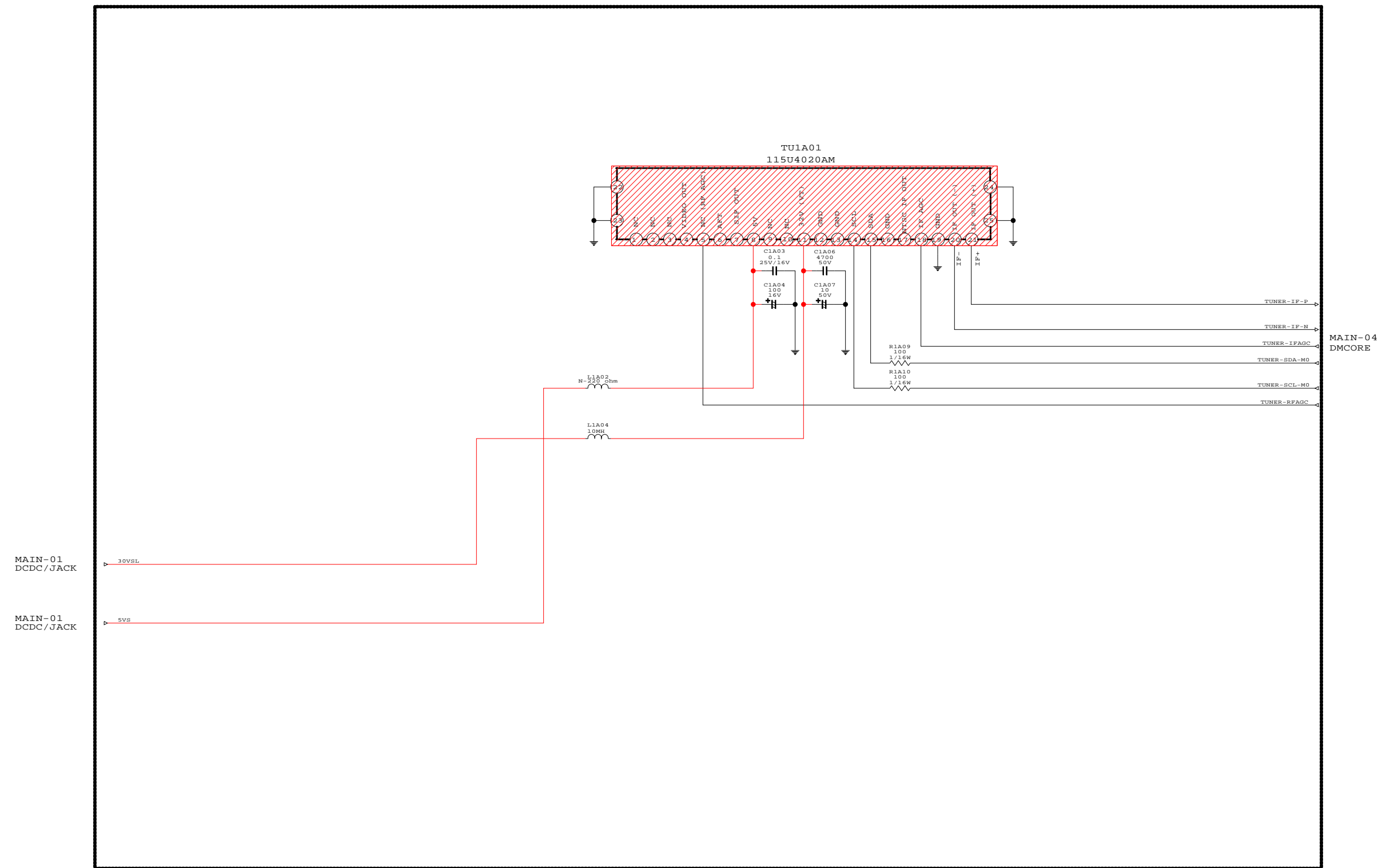

4 of 13 MAIN-02 TUNER / IO
 SHADED COMPONENTS HAVE SPECIAL CHARACTERISTICS IMPORTANT TO SAFETY. BEFORE REPLACING ANY OF THESE COMPONENTS, READ CAREFULLY THE PRODUCT SAFETY NOTICE IN THE SERVICE MANUAL. DON'T DEGRADE THE SAFETY OF THE RECEIVER THROUGH IMPROPER SERVICING.

Table of Contents		
Page No.	Page Title	Page Contents
1 of 13	BLOCK	Writing Diagram
2 of 13	PWB-POWER	Power Supply
3 of 13	MAIN-01	DC-DC / JACK
4 of 13	MAIN-02	TUNER / IO
5 of 13	MAIN-03	HDMI
6 of 13	MAIN-04	DM-CORE
7 of 13	MAIN-05	DM-MEMORY
8 of 13	MAIN-06	ROM / EBI
9 of 13	MAIN-07	ASIC
10 of 13	MAIN-08	TMDS
11 of 13	MAIN-09	AUDIO
12 of 13	MAIN-10	MICRO
13 of 13	MISC PWBs	Control_LED, Preamp, SW-Lamp, RS232, SBL

Model	Chassis
WD-60C9	V41C
WD-65C9	V41C
WD-73C9	V41C
WD-60737	V41
WD-65737	V41
WD-73737	V41
WD-82737	V41
WD-65837	V41+
WD-73837	V41+
WD-82837	V41+

PIN	Signal Assignment
1	T.M.D.S. Data 2+
2	T.M.D.S. Data 2 Shield
3	T.M.D.S. Data 2-
4	T.M.D.S. Data 1+
5	T.M.D.S. Data 1 Shield
6	T.M.D.S. Data 1-
7	T.M.D.S. Data 0+
8	T.M.D.S. Data 0 Shield
9	T.M.D.S. Data 0-
10	T.M.D.S. Clock+
11	T.M.D.S. Clock Shield
12	T.M.D.S. Clock-
13	CEC
14	Reserve
15	BDC Clock
16	BDC Data
17	Ground (return for +5V)
18	+5V Power
19	Hot Plug Detect
Shell	FD
(20)	Location Post (SMD)
(21)	Location Post (SMD)
(22)	Location Post (SMD)
(23)	Location Post (SMD)

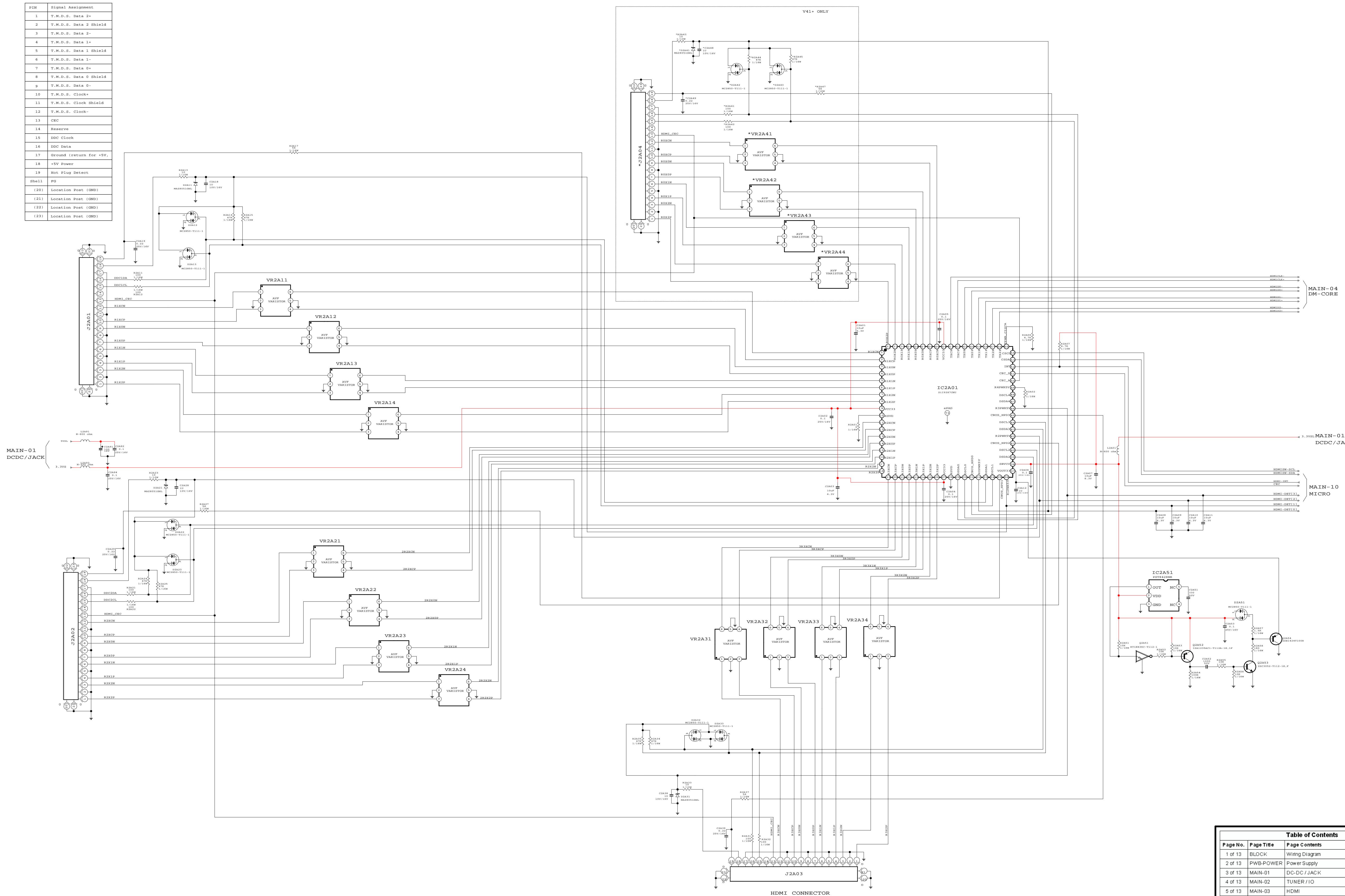

5 of 13 MAIN-03 HDMI

SHADED COMPONENTS HAVE SPECIAL CHARACTERISTICS IMPORTANT TO SAFETY. BEFORE REPLACING ANY OF THESE COMPONENTS, READ CAREFULLY THE PRODUCT SAFETY NOTICE IN THE SERVICE MANUAL. DON'T DEGRADE THE SAFETY OF THE RECEIVER THROUGH IMPROPER SERVICING.

Table of Contents		
Page No.	Page Title	Page Contents
1 of 13	BLOCK	Wiring Diagram
2 of 13	PWB-POWER	Power Supply
3 of 13	MAIN-01	DC-DC / JACK
4 of 13	MAIN-02	TUNER / I/O
5 of 13	MAIN-03	HDMI
6 of 13	MAIN-04	DM-CORE
7 of 13	MAIN-05	DM-MEMORY
8 of 13	MAIN-06	ROM / EBI
9 of 13	MAIN-07	ASIC
10 of 13	MAIN-08	TMDS
11 of 13	MAIN-09	AUDIO
12 of 13	MAIN-10	MICRO
13 of 13	MISC PWBs	Control_LED, Preamp, SW-Lamp, RS232, SBL

Model	Chassis
WD-60C9	V41C
WD-65C9	V41C
WD-73C9	V41C
WD-60737	V41
WD-65737	V41
WD-73737	V41
WD-82737	V41
WD-65837	V41+
WD-73837	V41+
WD-82837	V41+

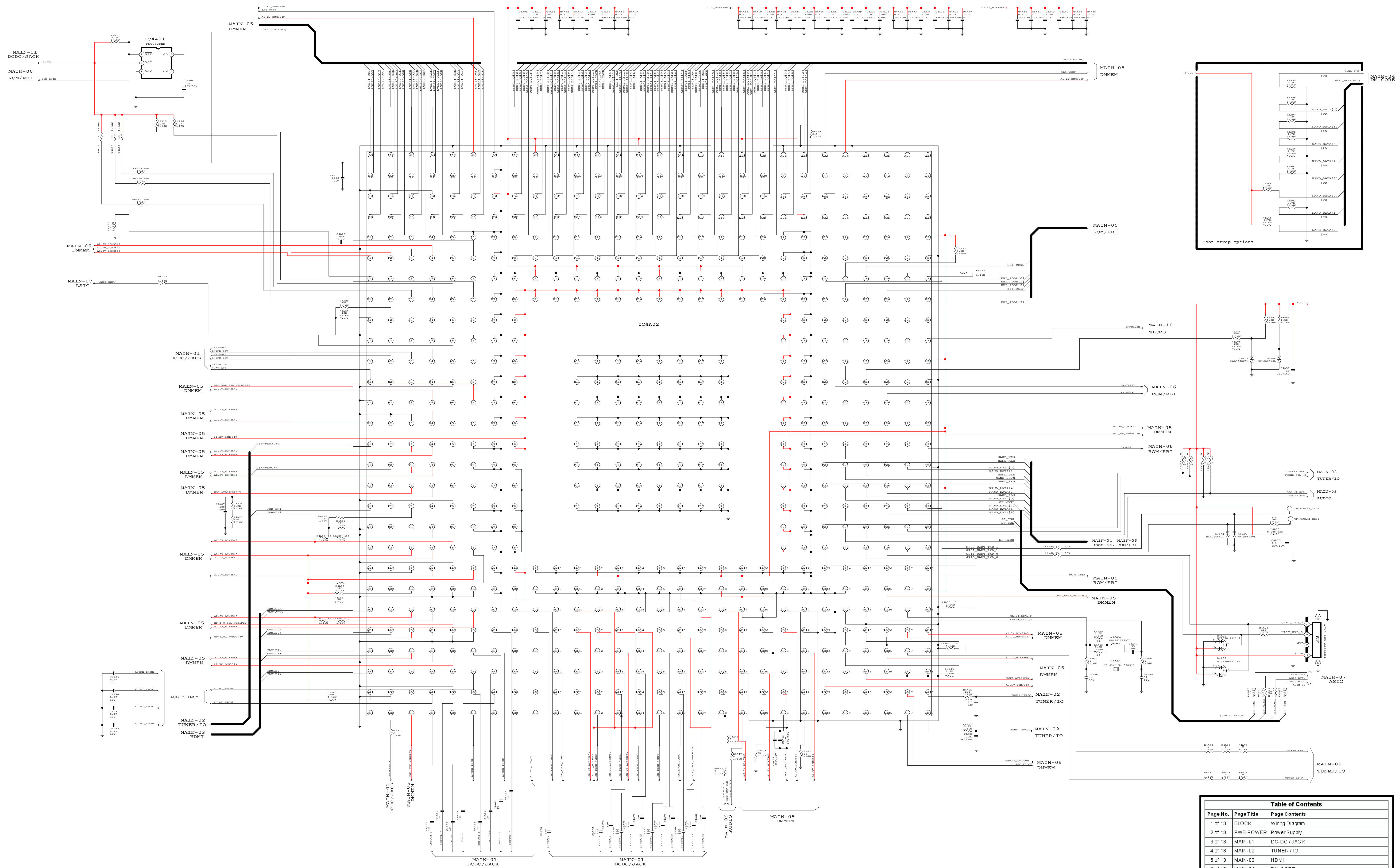

6 of 13 MAIN-04 DM-CORE

SHADED COMPONENTS HAVE SPECIAL CHARACTERISTICS IMPORTANT TO SAFETY. BEFORE REPLACING ANY OF THESE COMPONENTS, READ CAREFULLY THE PRODUCT SAFETY NOTICE IN THE SERVICE MANUAL. DON'T DEGRADE THE SAFETY OF THE RECEIVER THROUGH IMPROPER SERVICING.

Table of Contents		
Page No.	Page Title	Page Contents
1 of 13	BLOCK	Wiring Diagram
2 of 13	PWB-POWER	Power Supply
3 of 13	MAIN-01	DC-DC / JACK
4 of 13	MAIN-02	TUNER / IO
5 of 13	MAIN-03	HDMI
6 of 13	MAIN-04	DM-CORE
7 of 13	MAIN-05	DM-MEMORY
8 of 13	MAIN-06	ROM / EBI
9 of 13	MAIN-07	ASIC
10 of 13	MAIN-08	TMDS
11 of 13	MAIN-09	AUDIO
12 of 13	MAIN-10	MICRO
13 of 13	MISC PWBs	Control_LED, Preamp, SW-Lamp, RS232, SBL

Model	Chassis
WD-60C9	V41C
WD-65C9	V41C
WD-73C9	V41C
WD-60737	V41
WD-65737	V41
WD-73737	V41
WD-82737	V41
WD-65837	V41+
WD-73837	V41+
WD-82837	V41+

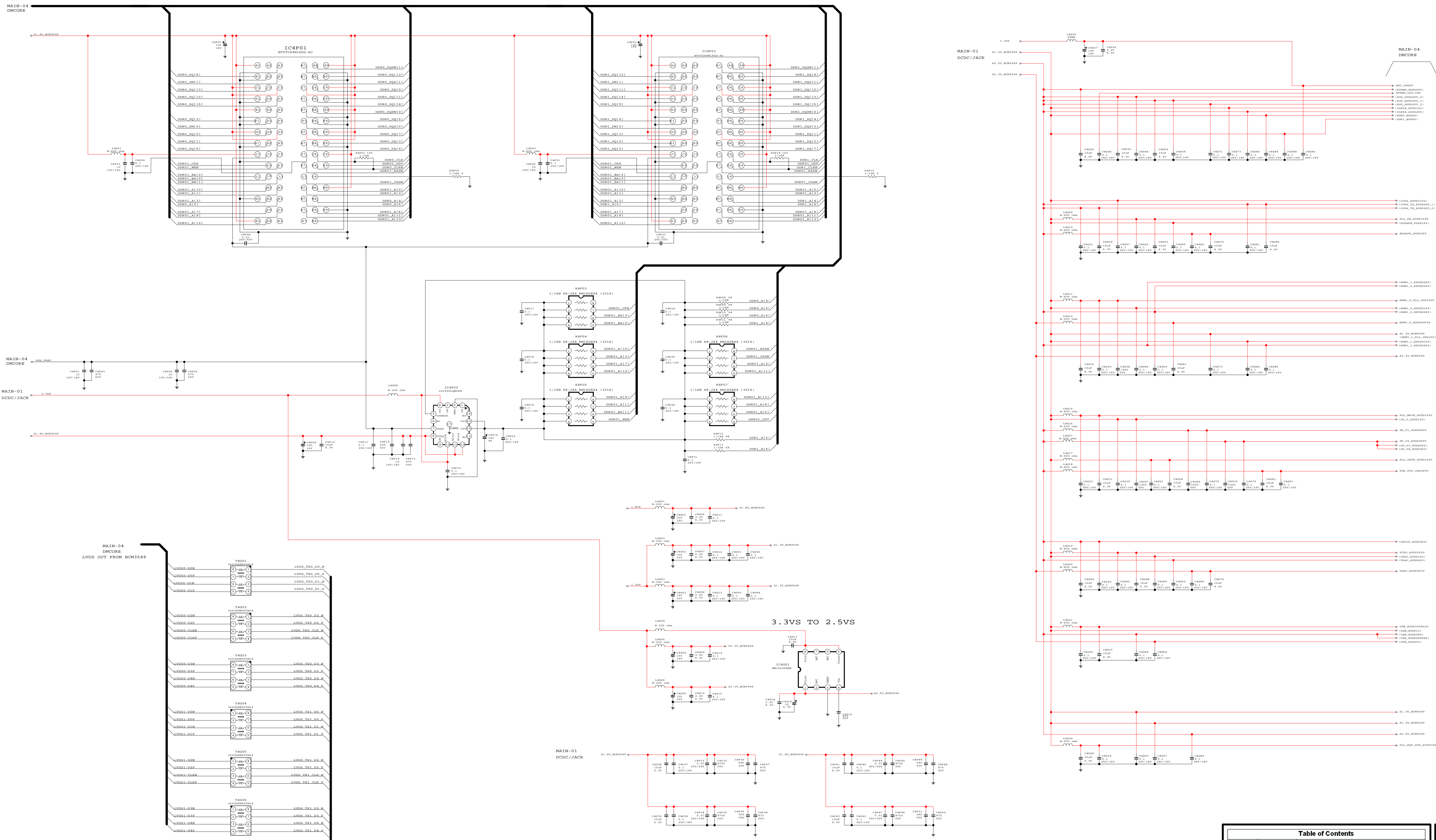

Page No.	Page Title	Page Contents
1 of 13	BLOCK	Wiring Diagram
2 of 13	PWB-POWER	Power Supply
3 of 13	MAIN-01	DC-DC / JACK
4 of 13	MAIN-02	TUNER / I/O
5 of 13	MAIN-03	HDMI
6 of 13	MAIN-04	DM-CORE
7 of 13	MAIN-05	DM-MEMORY
8 of 13	MAIN-06	ROM / EBI
9 of 13	MAIN-07	ASIC
10 of 13	MAIN-08	TMDS
11 of 13	MAIN-09	AUDIO
12 of 13	MAIN-10	MICRO
13 of 13	MISC PWBs	Control_LED, Preamp, SW-Lamp, RS232, SBL

Model	Chassis
WD-60C9	V41C
WD-65C9	V41C
WD-73C9	V41C
WD-60737	V41
WD-65737	V41
WD-73737	V41
WD-82737	V41
WD-65837	V41+
WD-73837	V41+
WD-82837	V41+

7 of 13 MAIN-05 DM-MEMORY

SHADED COMPONENTS HAVE SPECIAL CHARACTERISTICS IMPORTANT TO SAFETY. BEFORE REPLACING ANY OF THESE COMPONENTS, READ CAREFULLY THE PRODUCT SAFETY NOTICE IN THE SERVICE MANUAL. DON'T DEGRADE THE SAFETY OF THE RECEIVER THROUGH IMPROPER SERVICING.

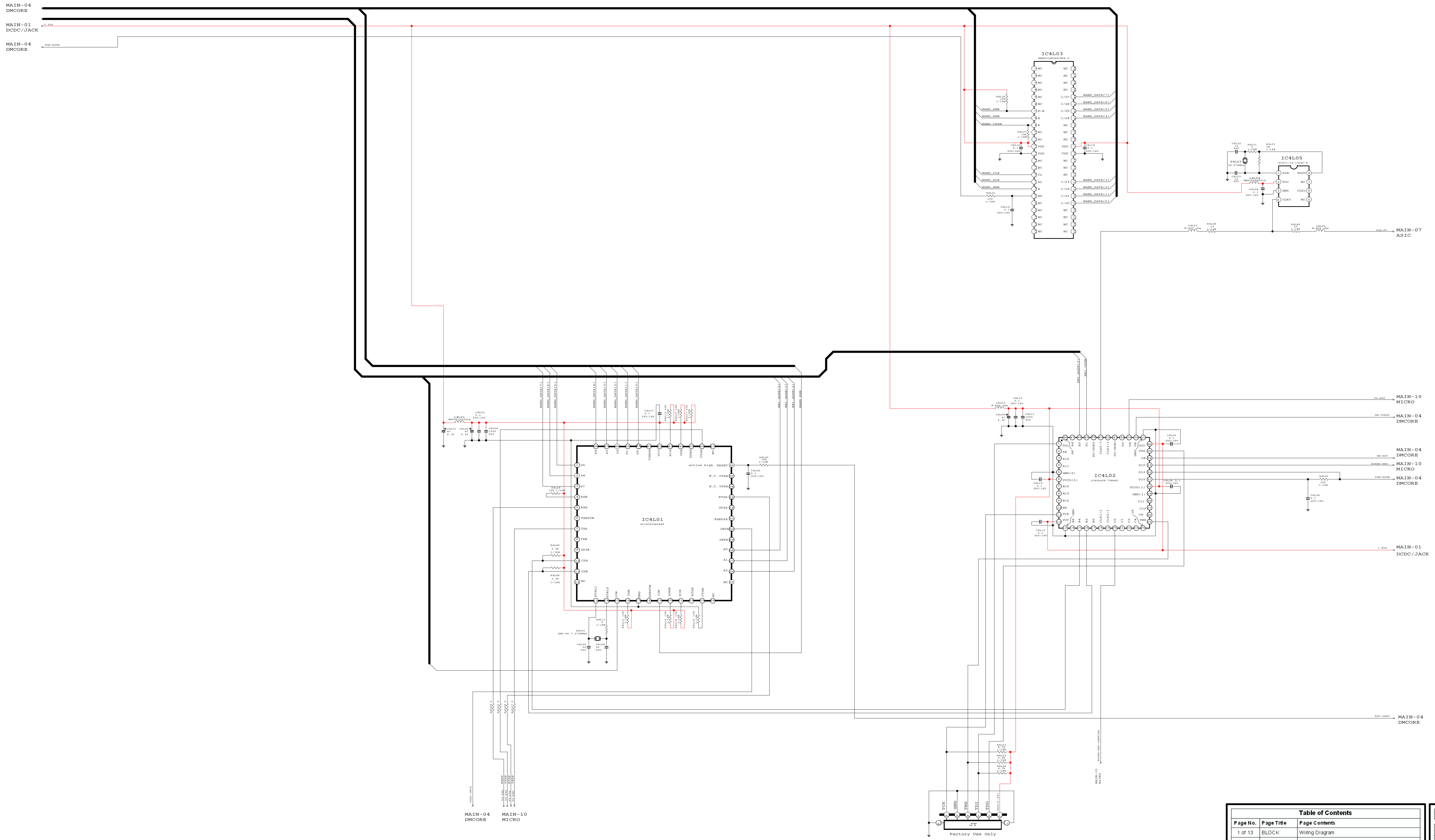

8 of 13 MAIN-06 ROM / EBI

SHADED COMPONENTS HAVE SPECIAL CHARACTERISTICS IMPORTANT TO SAFETY. BEFORE REPLACING ANY OF THESE COMPONENTS, READ CAREFULLY THE PRODUCT SAFETY NOTICE IN THE SERVICE MANUAL. DON'T DEGRADE THE SAFETY OF THE RECEIVER THROUGH IMPROPER SERVICING.

Table of Contents		
Page No.	Page Title	Page Contents
1 of 13	BLOCK	Writing Diagram
2 of 13	PWB-POWER	Power Supply
3 of 13	MAIN-01	DC-DC / JACK
4 of 13	MAIN-02	TUNER / I/O
5 of 13	MAIN-03	HDMI
6 of 13	MAIN-04	DM-CORE
7 of 13	MAIN-05	DM-MEMORY
8 of 13	MAIN-06	ROM / EBI
9 of 13	MAIN-07	ASIC
10 of 13	MAIN-08	TMDS
11 of 13	MAIN-09	AUDIO
12 of 13	MAIN-10	MICRO
13 of 13	MISC PWBs	Control_LED, Preamp, SW-Lamp, RS232, SBL

Model	Chassis
WD-60C9	V41C
WD-65C9	V41C
WD-73C9	V41C
WD-60737	V41
WD-65737	V41
WD-73737	V41
WD-82737	V41
WD-65837	V41+
WD-73837	V41+
WD-82837	V41+

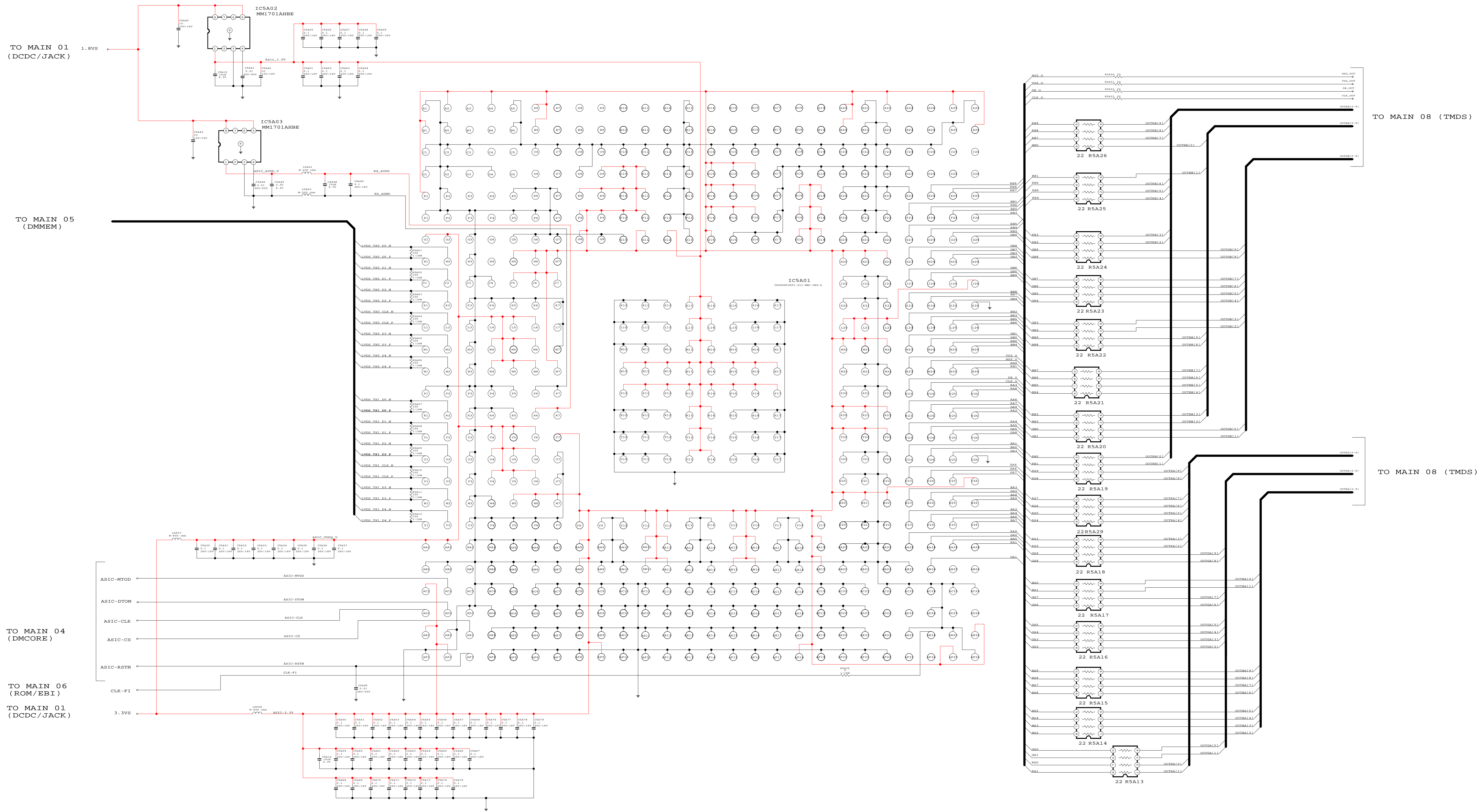

Table of Contents		
Page No.	Page Title	Page Contents
1 of 13	BLOCK	Writing Diagram
2 of 13	PWB-POWER	Power Supply
3 of 13	MAIN-01	DC-DC / JACK
4 of 13	MAIN-02	TUNER / I/O
5 of 13	MAIN-03	HDMI
6 of 13	MAIN-04	DM-CORE
7 of 13	MAIN-05	DM-MEMORY
8 of 13	MAIN-06	ROM / EBI
9 of 13	MAIN-07	ASIC
10 of 13	MAIN-08	TMDS
11 of 13	MAIN-09	AUDIO
12 of 13	MAIN-10	MICRO
13 of 13	MISC PWBs	Control_LED, Preamp, SW-Lamp, RS232, SBL

Model	Chassis
WD-60C9	V41C
WD-65C9	V41C
WD-73C9	V41C
WD-60737	V41
WD-65737	V41
WD-73737	V41
WD-82737	V41
WD-65837	V41+
WD-73837	V41+
WD-82837	V41+

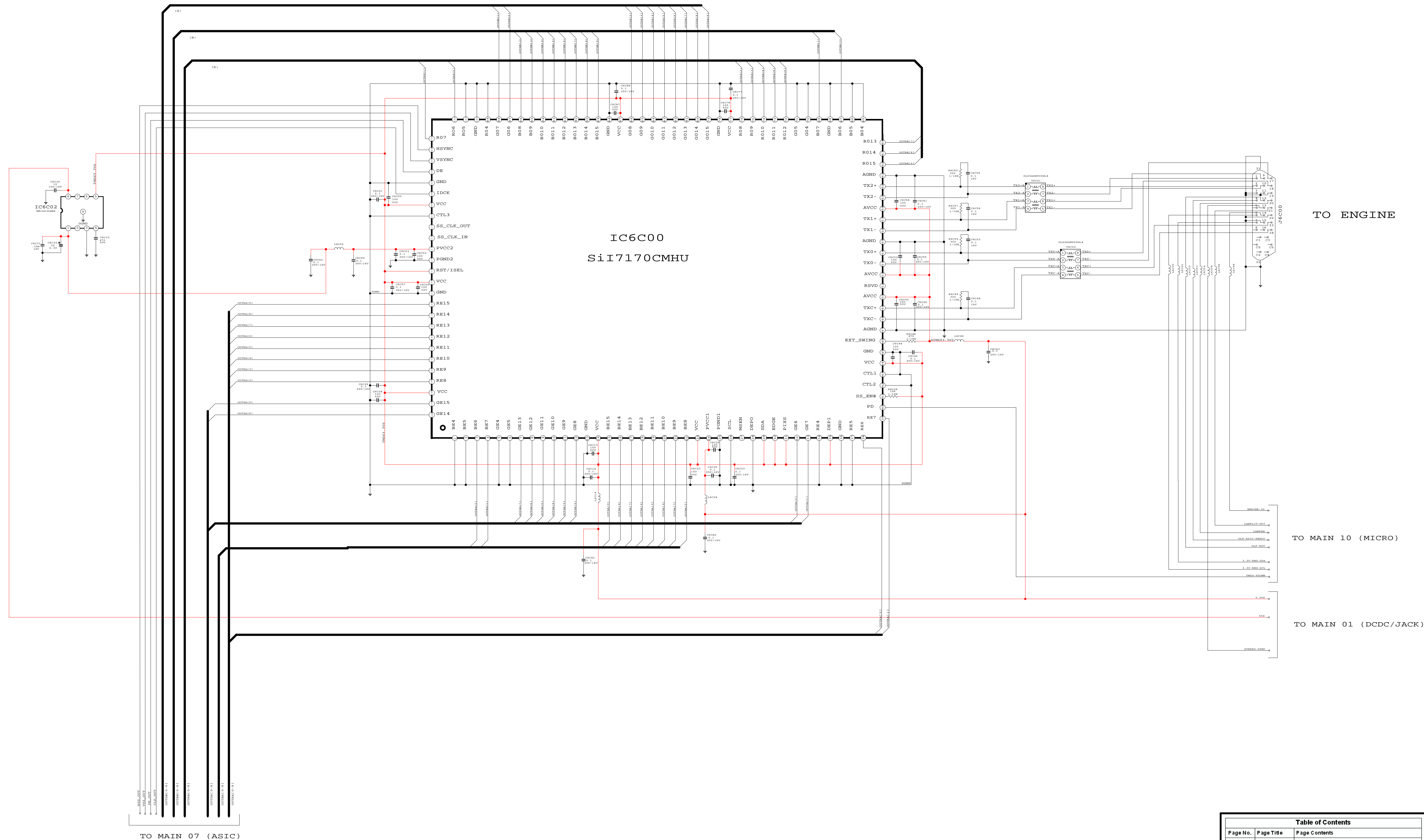

Table of Contents			Model	Chassis
Page No.	Page Title	Page Contents		
1 of 13	BLOCK	Writing Diagram	WD-60C9	V41C
2 of 13	PWB-POWER	Power Supply	WD-65C9	V41C
3 of 13	MAIN-01	DC-DC / JACK	WD-73C9	V41C
4 of 13	MAIN-02	TUNER / IO		
5 of 13	MAIN-03	HDMI	WD-60737	V41
6 of 13	MAIN-04	DM-CORE	WD-65737	V41
7 of 13	MAIN-05	DM-MEMORY	WD-73737	V41
8 of 13	MAIN-06	ROM / EBI		
9 of 13	MAIN-07	ASIC	WD-82737	V41
10 of 13	MAIN-08	TMDS	WD-65837	V41+
11 of 13	MAIN-09	AUDIO	WD-73837	V41+
12 of 13	MAIN-10	MICRO	WD-82837	V41+
13 of 13	MISC PWBs	Control_LED, Preamp, SW-Lamp, RS232, SBL		

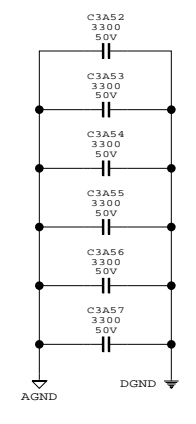
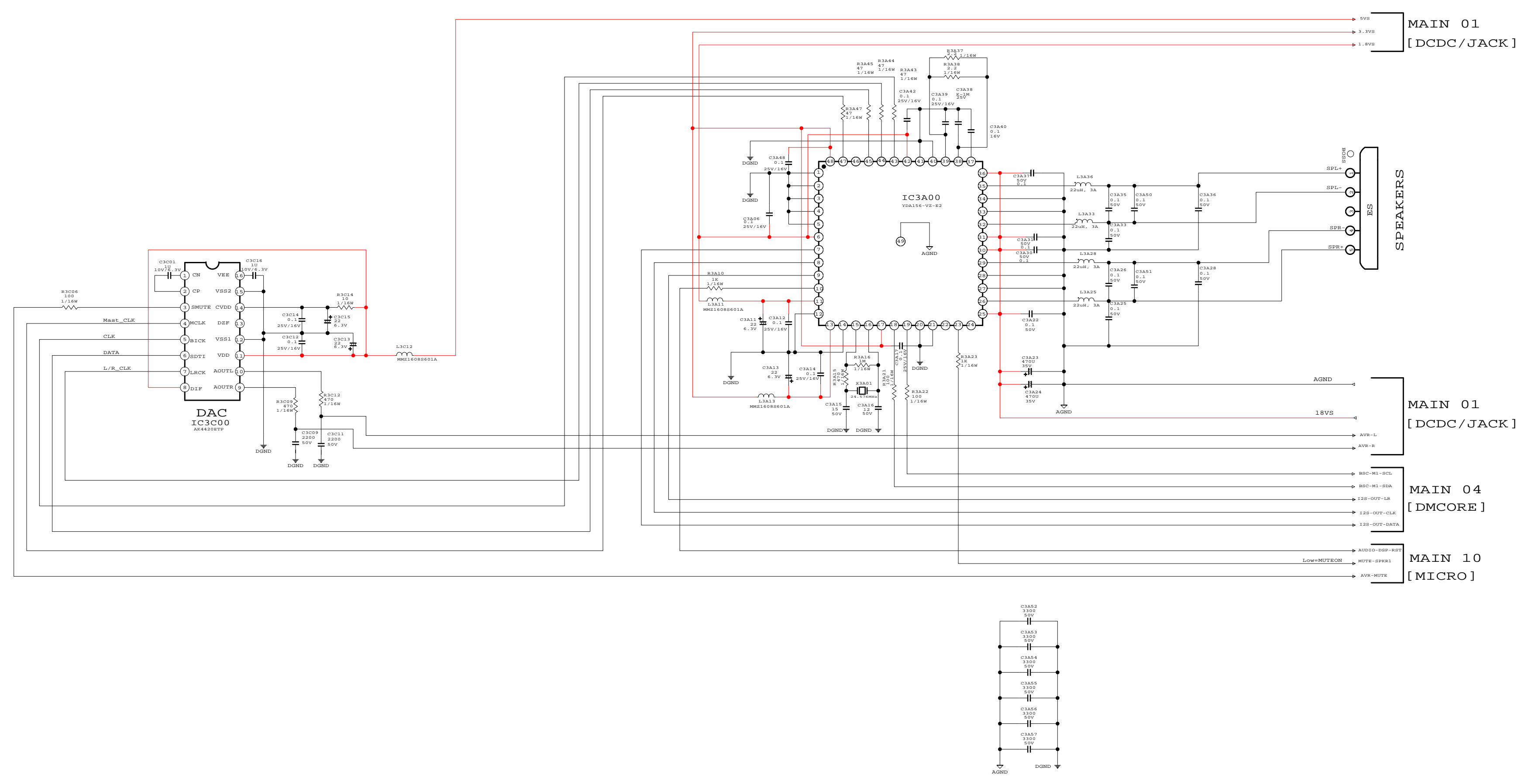
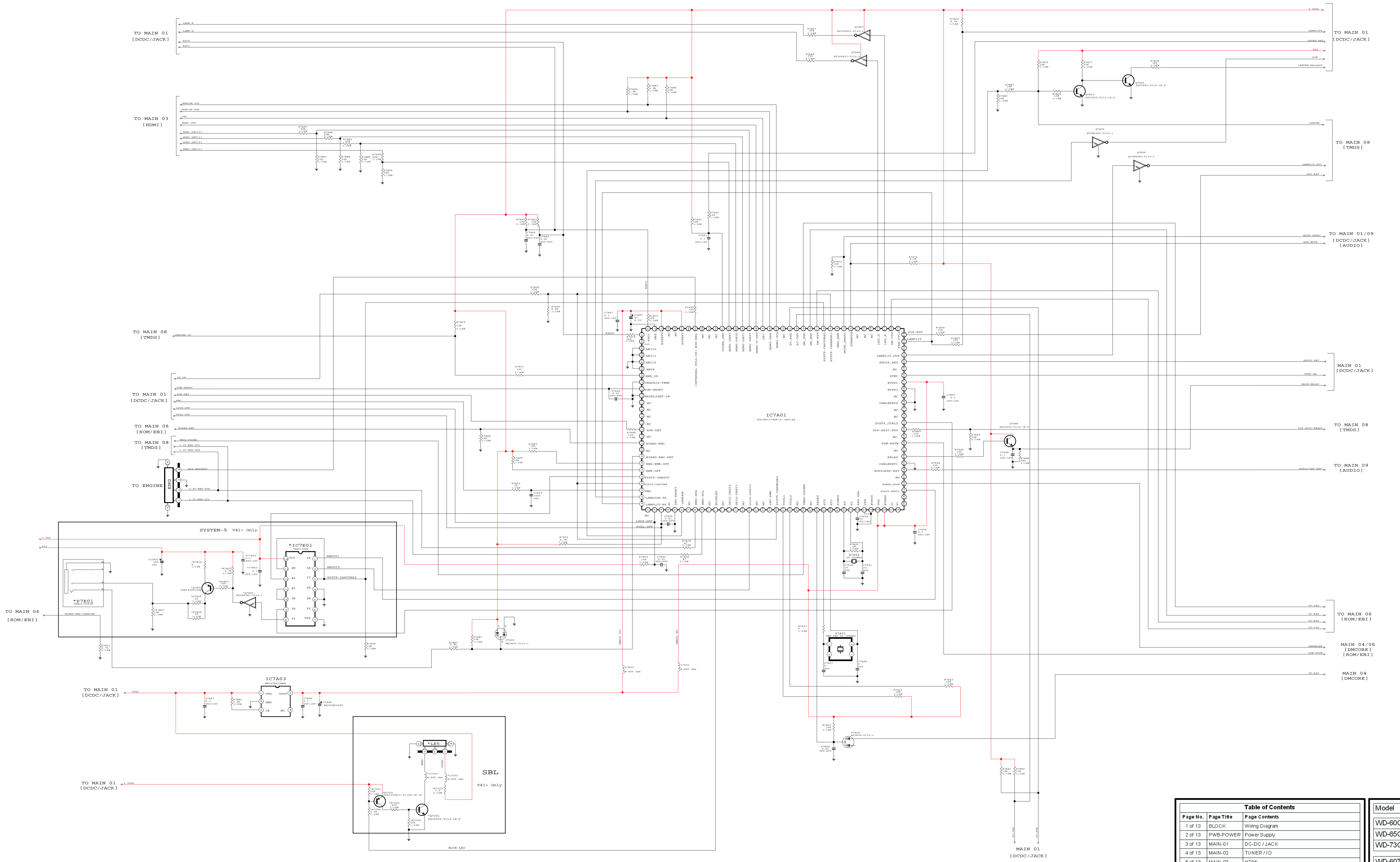

Table of Contents		
Page No.	Page Title	Page Contents
1 of 13	BLOCK	Wiring Diagram
2 of 13	PWB-POWER	Power Supply
3 of 13	MAIN-01	DC-DC / JACK
4 of 13	MAIN-02	TUNER / I/O
5 of 13	MAIN-03	HDMI
6 of 13	MAIN-04	DM-CORE
7 of 13	MAIN-05	DM-MEMORY
8 of 13	MAIN-06	ROM / EBI
9 of 13	MAIN-07	ASIC
10 of 13	MAIN-08	TMDS
11 of 13	MAIN-09	AUDIO
12 of 13	MAIN-10	MICRO
13 of 13	MISC PWBs	Control_LED, Preamp, SW-Lamp, RS232, SBL

Model	Chassis
WD-60C9	V41C
WD-65C9	V41C
WD-73C9	V41C
WD-60737	V41
WD-65737	V41
WD-73737	V41
WD-82737	V41
WD-65837	V41+
WD-73837	V41+
WD-82837	V41+

11 of 13 MAIN-09 AUDIO

SHADED COMPONENTS HAVE SPECIAL CHARACTERISTICS IMPORTANT TO SAFETY. BEFORE REPLACING ANY OF THESE COMPONENTS, READ CAREFULLY THE PRODUCT SAFETY NOTICE IN THE SERVICE MANUAL. DON'T DEGRADE THE SAFETY OF THE RECEIVER THROUGH IMPROPER SERVICING.



12 of 13 MAIN-10 MICRO
 SHADED COMPONENTS HAVE SPECIAL CHARACTERISTICS IMPORTANT TO SAFETY. BEFORE REPLACING ANY OF THESE COMPONENTS, READ CAREFULLY THE PRODUCT SAFETY NOTICE IN THE SERVICE MANUAL. DON'T DEGRADE THE SAFETY OF THE RECEIVER THROUGH IMPROPER SERVICING.

Table of Contents		
Page No.	Page Title	Page Contents
1 of 13	BLOCK	Wiring Diagram
2 of 13	PWB-POWER	Power Supply
3 of 13	MAIN-01	DC-DC / JACK
4 of 13	MAIN-02	TUNER / I/O
5 of 13	MAIN-03	HDMI
6 of 13	MAIN-04	DM-CORE
7 of 13	MAIN-05	DM-MEMORY
8 of 13	MAIN-06	ROM / EBI
9 of 13	MAIN-07	ASIC
10 of 13	MAIN-08	TMDS
11 of 13	MAIN-09	AUDIO
12 of 13	MAIN-10	MICRO
13 of 13	MISC PWBs	Control_LED, Preamp, SW-Lamp, RS232, SBL

Model	Chassis
WD-60C9	V41C
WD-65C9	V41C
WD-73C9	V41C
WD-60737	V41
WD-65737	V41
WD-73737	V41
WD-82737	V41
WD-65837	V41+
WD-73837	V41+
WD-82837	V41+

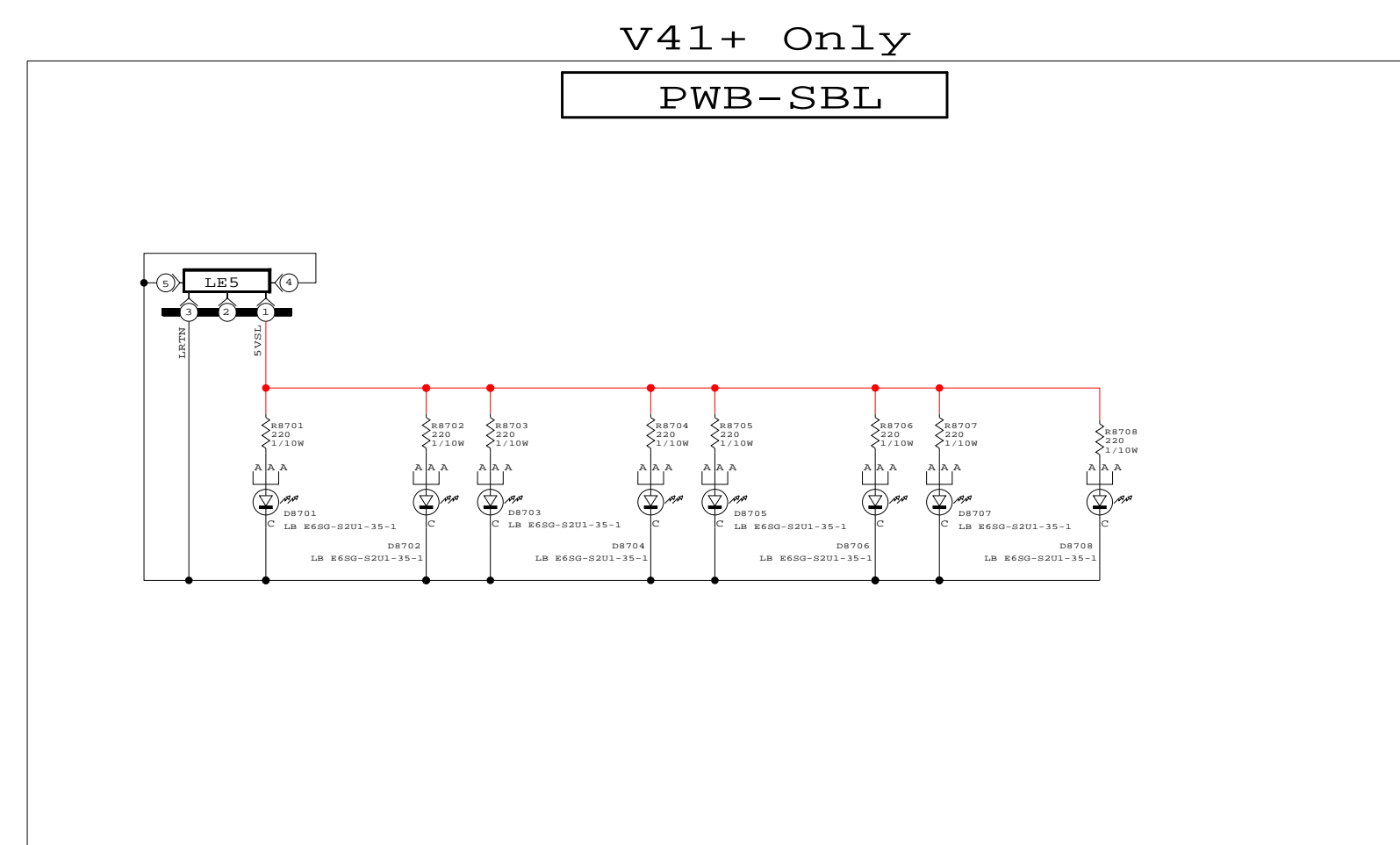
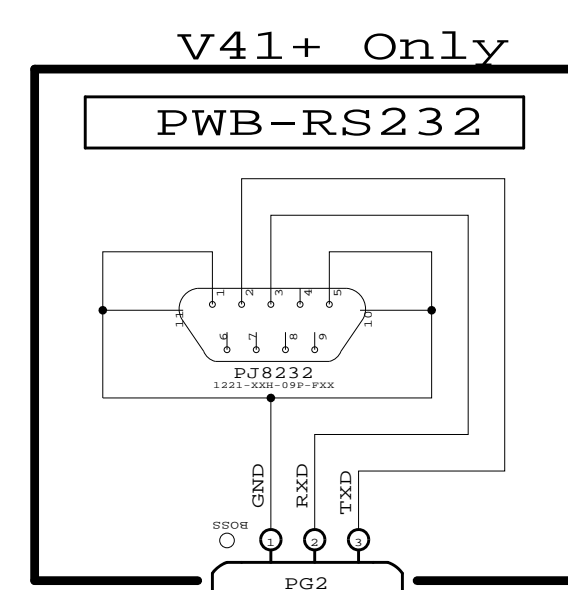
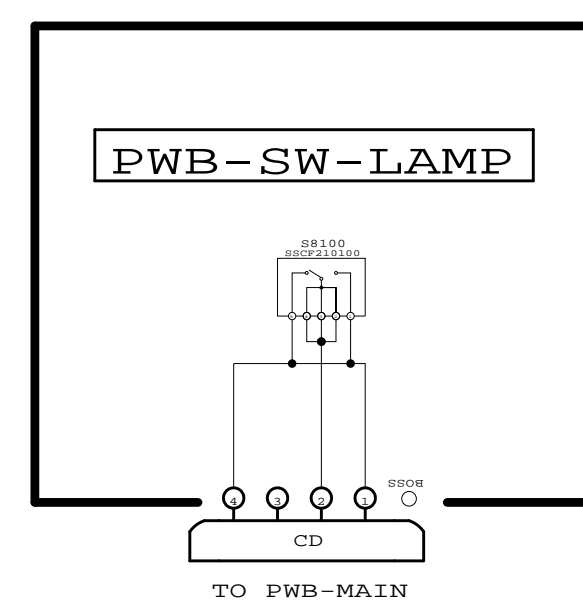
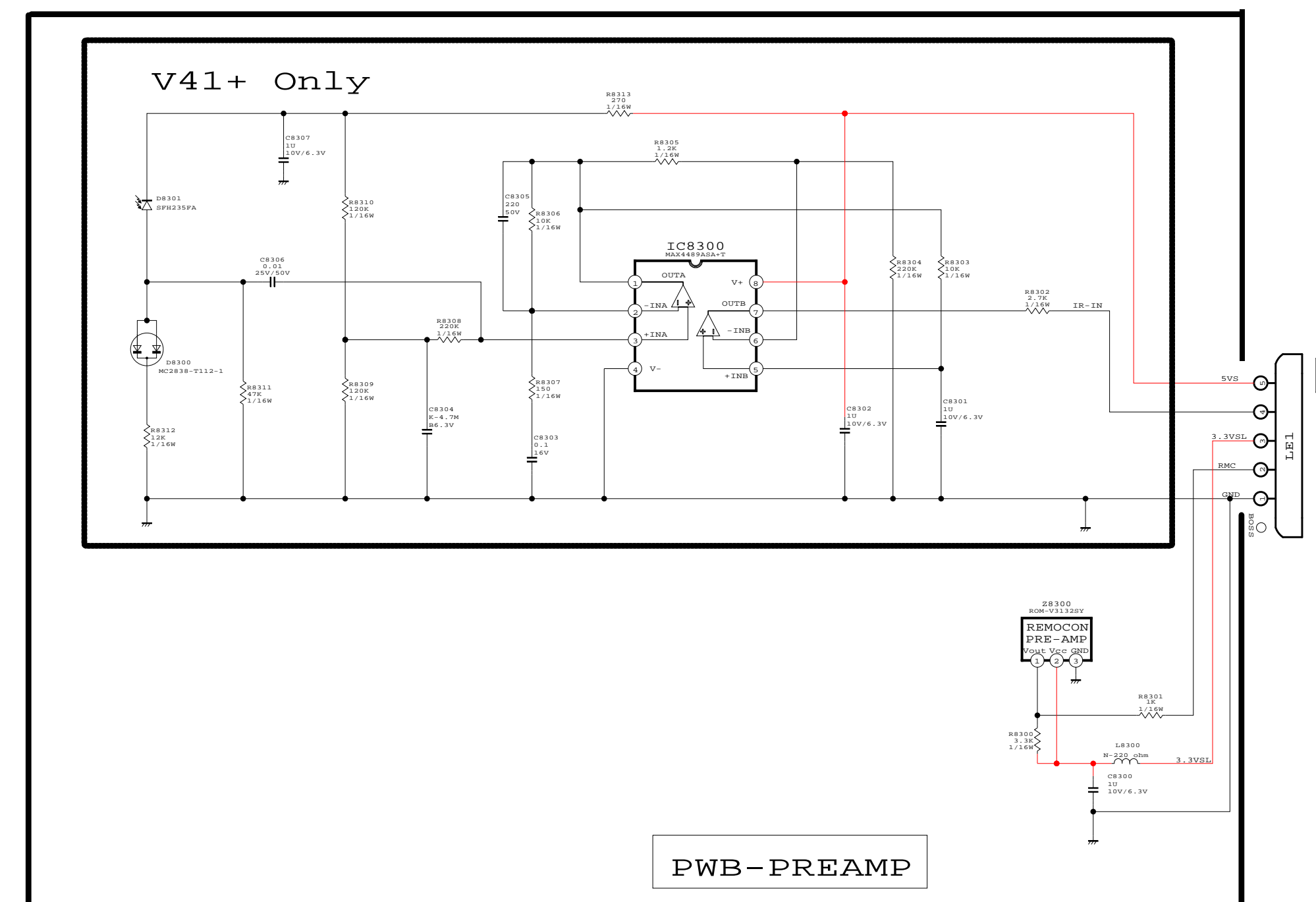
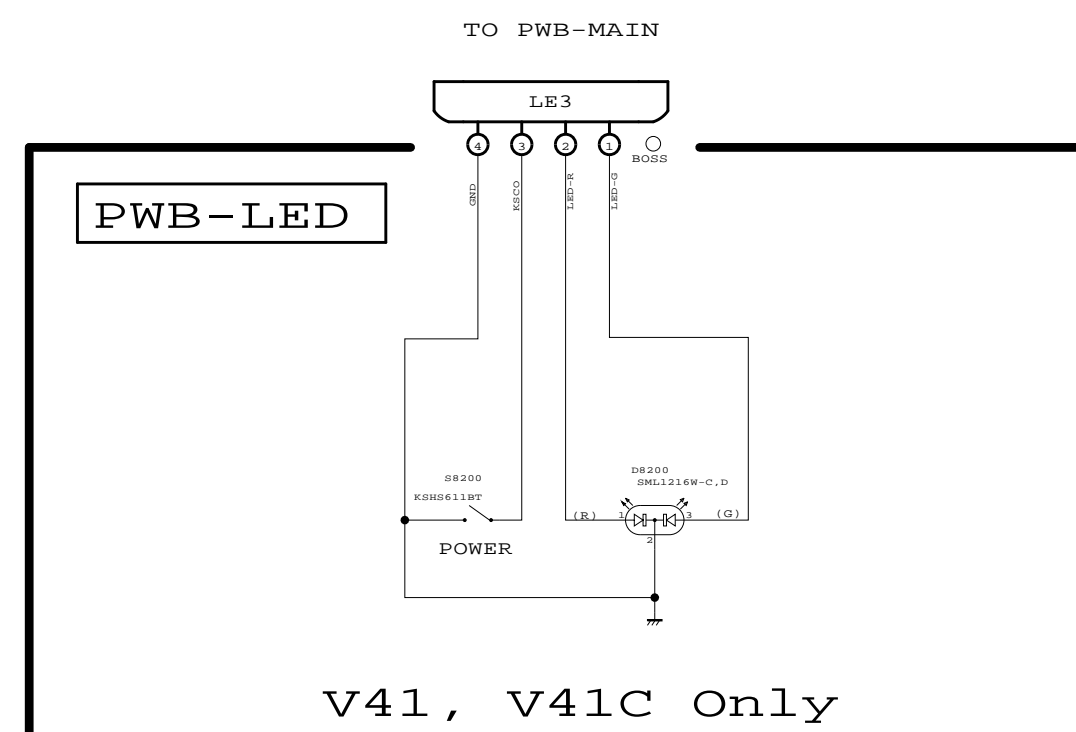
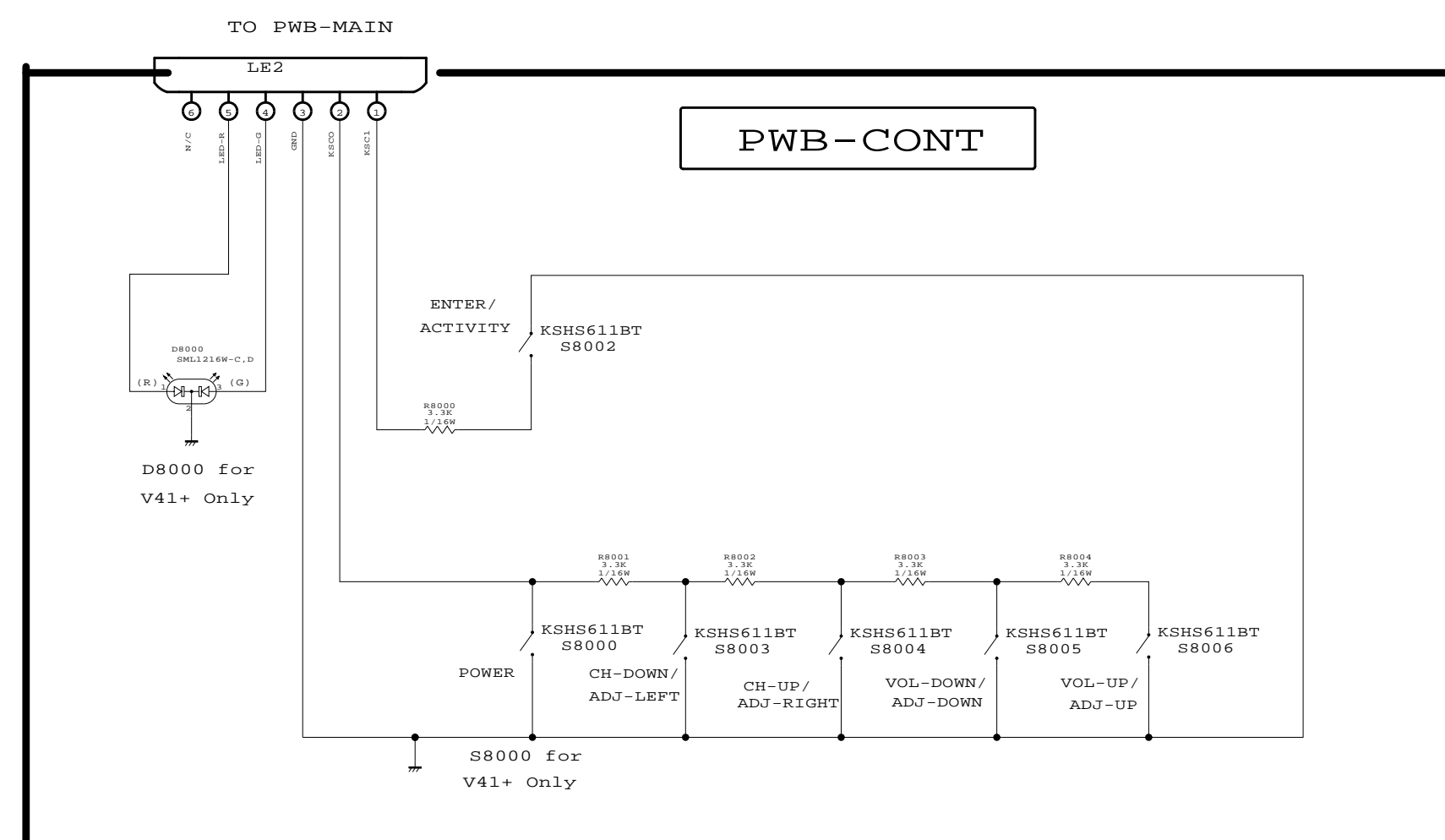

13 of 13 MISC PWBs Control, LED, Preamp, SW-Lamp, RS232, SBL

SHADED COMPONENTS HAVE SPECIAL CHARACTERISTICS IMPORTANT TO SAFETY. BEFORE REPLACING ANY OF THESE COMPONENTS, READ CAREFULLY THE PRODUCT SAFETY NOTICE IN THE SERVICE MANUAL. DON'T DEGRADE THE SAFETY OF THE RECEIVER THROUGH IMPROPER SERVICING.

Table of Contents		
Page No.	Page Title	Page Contents
1 of 13	BLOCK	Writing Diagram
2 of 13	PWB-POWER	Power Supply
3 of 13	MAIN-01	DC-DC / JACK
4 of 13	MAIN-02	TUNER / IO
5 of 13	MAIN-03	HDMI
6 of 13	MAIN-04	DM-CORE
7 of 13	MAIN-05	DM-MEMORY
8 of 13	MAIN-06	ROM / EBI
9 of 13	MAIN-07	ASIC
10 of 13	MAIN-08	TMDS
11 of 13	MAIN-09	AUDIO
12 of 13	MAIN-10	MICRO
13 of 13	MISC PWBs	Control, LED, Preamp, SW-Lamp, RS232, SBL

Model	Chassis
WD-60C9	V41C
WD-65C9	V41C
WD-73C9	V41C
WD-60737	V41
WD-65737	V41
WD-73737	V41
WD-82737	V41
WD-65837	V41+
WD-73837	V41+
WD-82837	V41+