

General-Purpose AC Servo

MELSERVO

MODEL

Servo Motor

INSTRUCTION MANUAL



● Safety Instructions ●

(Always read these instructions before using the equipment.)

Do not attempt to install, operate, maintain or inspect the servo amplifier and servo motor until you have read through this Instruction Manual, MELSERVO Servo Amplifier Installation Guide/Instruction Manual and appended documents carefully and can use the equipment correctly. Do not use the servo amplifier and servo motor until you have a full knowledge of the equipment, safety information and instructions.

In this Instruction Manual, the safety instruction levels are classified into "WARNING" and "CAUTION".



Indicates that incorrect handling may cause hazardous conditions, resulting in death or severe injury.





Indicates that incorrect handling may cause hazardous conditions, resulting in medium or slight injury to personnel or may cause physical damage.

Note that the CAUTION level may lead to a serious consequence according to conditions. Please follow the instructions of both levels because they are important to personnel safety.

What must not be done and what must be done are indicated by the following diagrammatic symbols.

 : Indicates what must not be done. For example, "No Fire" is indicated by .

 : Indicates what must be done. For example, grounding is indicated by .

In this Instruction Manual, instructions at a lower level than the above, instructions for other functions, and so on are classified into "POINT".

After reading this installation guide, always keep it accessible to the operator.

1. To prevent electric shock, note the following

 **WARNING**

- Before wiring or inspection, turn off the power and wait for 15 minutes or more until the charge lamp turns off. Then, confirm that the voltage between P and N is safe with a voltage tester and others. Otherwise, an electric shock may occur. In addition, always confirm from the front of the servo amplifier, whether the charge lamp is off or not.
- Connect the servo amplifier and servo motor to ground.
- Any person who is involved in wiring and inspection should be fully competent to do the work.
- Do not attempt to wire the servo amplifier and servo motor until they have been installed. Otherwise, you may get an electric shock.
- Operate the switches with dry hand to prevent an electric shock.
- The cables should not be damaged, stressed loaded, or pinched. Otherwise, you may get an electric shock.
- During power-on or operation, do not open the front cover of the servo amplifier. You may get an electric shock.
- Do not operate the servo amplifier with the front cover removed. High-voltage terminals and charging area are exposed and you may get an electric shock.
- Except for wiring or periodic inspection, do not remove the front cover of the servo amplifier even if the power is off. The servo amplifier is charged and you may get an electric shock.

2. To prevent fire, note the following.

 **CAUTION**

- Install the servo amplifier, servo motor and regenerative resistor on incombustible material. Installing them directly or close to combustibles will lead to a fire.
- Always connect a magnetic contactor (MC) between the main circuit power supply and L1, L2, and L3 of the servo amplifier, and configure the wiring to be able to shut down the power supply on the side of the servo amplifier's power supply. If a magnetic contactor (MC) is not connected, continuous flow of a large current may cause a fire when the servo amplifier malfunctions.
- When a regenerative resistor is used, use an alarm signal to switch main power off. Otherwise, a regenerative transistor fault or the like may overheat the regenerative resistor, causing a fire.

3. To prevent injury, note the follow

 **CAUTION**

- Only the voltage specified in the Instruction Manual should be applied to each terminal, Otherwise, a burst, damage, etc. may occur.
- Connect the terminals correctly to prevent a burst, damage, etc.
- Ensure that polarity (+, -) is correct. Otherwise, a burst, damage, etc. may occur.
- Take safety measures, e.g. provide covers, to prevent accidental contact of hands and parts (cables, etc.) with the servo amplifier heat sink, regenerative resistor, servo motor, etc. since they may be hot while power is on or for some time after power-off. Their temperatures may be high and you may get burnt or a parts may damaged.
- During operation, never touch the rotating parts of the servo motor. Doing so can cause injury.

4. Additional instructions

The following instructions should also be fully noted. Incorrect handling may cause a fault, injury, electric shock, etc.

(1) Transportation and installation

⚠ CAUTION

- Transport the products correctly according to their weights.
- Use the eye-bolt of the servo motor to only transport the servo motor and do not use it to transport in the condition to have installed a servo motor on the machine.
- Stacking in excess of the specified number of products is not allowed.
- Do not carry the servo motor by the cables, shaft or encoder.
- Do not hold the front cover to transport the servo amplifier. The servo amplifier may drop.
- Install the servo amplifier in a load-bearing place in accordance with the Instruction Manual.
- Do not climb or stand on servo equipment. Do not put heavy objects on equipment.
- The servo motor must be installed in the specified direction.
- Leave specified clearances between the servo amplifier and control enclosure walls or other equipment.
- Do not install or operate the servo motor which has been damaged or has any parts missing.
- Do not block the intake/exhaust port of the servo motor which has a cooling fan.
- Provide adequate protection to prevent screws and other conductive matter, oil and other combustible matter from entering the servo amplifier and servo motor.
- Do not drop or strike servo motor. Isolate from all impact loads.
- When you keep or use it, please fulfill the following environmental conditions.

Environment		Conditions		
Ambient temperature	In Operation	[°C]	0 to +40 (non-freezing)	
		[°F]	32 to 104 (non-freezing)	
	In Storage	[°C]	-15 to 70 (non-freezing)	
		[°F]	5 to 158 (non-freezing)	
Ambient humidity	In Operation	80%RH or less (non-condensing)		
	In Storage	90%RH or less (non-condensing)		
Ambience		Indoors (no direct sunlight) Free from corrosive gas, flammable gas, oil mist, dust and dirt		
Altitude		Max. 1000m (3280 ft) above sea level		
(Note) Vibration	[m/s ²]	HC-KFS series HC-MFS series	HC-UFS13 to 73	X,Y:49
		HC-SFS81 HC-SFS52 to 152 HC-SFS53 to 153	HC-SFS524 to 1524 HC-RFS series HC-UFS72 • 152	X,Y:24.5
		HC-SFS121 • 201 HC-SFS202 • 352 HC-SFS203 • 353	HC-SFS2024 • 3524 HC-UFS202 to 502	X:24.5 Y:49
		HC-SFS301 HC-SFS502 • 702	HC-SFS5024 • 7024	X:24.5 Y:29.4
		HC-AQ series HC-KF series HC-MF series	HA-FF series HC-UF13 to 73	X,Y:19.6
		HC-SF81 HC-SF52 to 152 HC-SF53 to 153	HC-RF series HC-UF72 • 152 HC-LFS52 to 152	X:9.8 Y:24.5
		HC-SF121 • 201 HC-SF202 • 352 HC-SF203 • 353	HC-UF202 to 502 HC-LFS202 • 302	X:19.6 Y:49
		HA-LFS601 to 12K1 HA-LFS701M to 15K1M HA-LFS502 to 22K2 HA-LFS6014 to 12K14 HA-LFS701M4 to 15K1M4 HA-LFS11K24 to 22K24	HA-LH11K2 to 22K2 HC-SF301 HC-SF502 • 702	X:11.7 Y:29.4
		HA-LFS15K1 to 37K1 HA-LFS22K1M to 37K1M HA-LFS30K2 • 37K2 HA-LFS15K14 to 37K14 HA-LFS22K1M4 to 50K1M4 HA-LFS30K24 to 55K24	HA-LF series	X,Y:9.8
		HC-KFS series HC-MFS series	HC-UFS13 to 73	X,Y:161
		HC-SFS81 HC-SFS52 to 152 HC-SFS53 to 153	HC-SFS524 to 1524 HC-RFS series HC-UFS72 • 152	X,Y:80
		HC-SFS121 • 201 HC-SFS202 • 352 HC-SFS203 • 353	HC-SFS2024 • 3524 HC-UFS202 to 502	X:80 Y:161

⚠ CAUTION

Environment		Conditions	
(Note) Vibration	[ft/s ²]	HC-SFS301 HC-SFS502 • 702	HC-SFS5024 • 7024 X:80 Y:96
		HC-AQ series HC-KF series HC-MF series	HA-FF series HC-UF13 to 73 X,Y:64
		HC-SF81 HC-SF52 to 152 HC-SF53 to 153	HC-RF series HC-UF72 • 152 HC-LFS52 to 152 X:32 Y:80
		HC-SF121 • 201 HC-SF202 • 352 HC-SF203 • 353	HC-UF202 to 502 HC-LFS202 • 302 X:64 Y:161
		HA-LFS601 to 12K1 HA-LFS701M to 15K1M HA-LFS502 to 22K2 HA-LFS6014 to 12K14 HA-LFS701M4 to 15K1M4 HA-LFS11K24 to 22K24	HA-LH11K2 to 22K2 HC-SF301 HC-SF502 • 702 X:38.4 Y:96.5
		HA-LFS15K1 to 37K1 HA-LFS22K1M to 37K1M HA-LFS30K2 • 37K2 HA-LFS15K14 to 37K14 HA-LFS22K1M4 to 50K1M4 HA-LFS30K24 to 55K24	HA-LF series X,Y:32

Note. Except the servo motor with reduction gear.

- Securely attach the servo motor to the machine. If attach insecurely, the servo motor may come off during operation.
- The servo motor with reduction gear must be installed in the specified direction to prevent oil leakage.
- Take safety measures, e.g. provide covers, to prevent accidental access to the rotating parts of the servo motor during operation.
- Never hit the servo motor or shaft, especially when coupling the servo motor to the machine. The encoder may become faulty.
- Do not subject the servo motor shaft to more than the permissible load. Otherwise, the shaft may break.

(2) Wiring

⚠ CAUTION

- Wire the equipment correctly and securely. Otherwise, the servo motor may operate unexpectedly.
- Do not install a power capacitor, surge absorber or radio noise filter (FR-BIF option) between the servo motor and servo amplifier.
- Connect the output terminals (U, V, W) correctly. Otherwise, the servo motor will operate improperly.
- Connect the servo motor power terminal (U, V, W) to the servo motor power input terminal (U, V, W) directly. Do not let a magnetic contactor, etc. intervene.

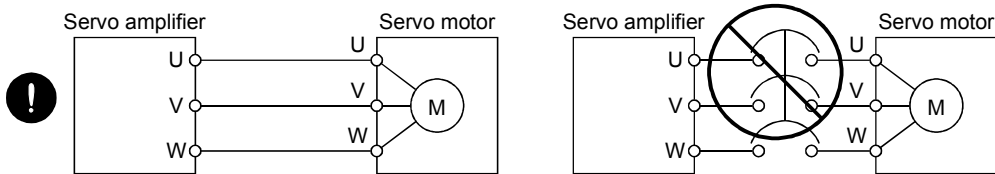

- Do not connect AC power directly to the servo motor. Otherwise, a fault may occur.
- The surge absorbing diode installed on the DC output signal of the servo amplifier relay must be wired in the specified direction. Otherwise, the forced stop and other protective circuits may not operate.

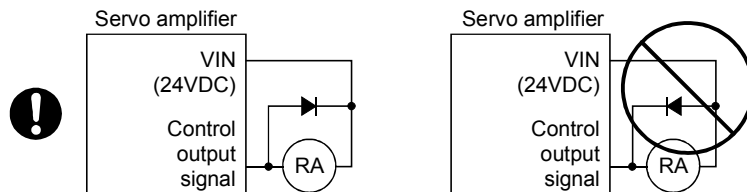

- When the cable is not tightened enough to the terminal block (connector), the cable or terminal block (connector) may generate heat because of the poor contact. Be sure to tighten the cable with specified torque.

(3) Test run adjustment

⚠ CAUTION

- Before operation, check the parameter settings. Improper settings may cause some machines to perform unexpected operation.
- The parameter settings must not be changed excessively. Operation will be insatiable.

(4) Usage

⚠ CAUTION

- Provide an external emergency stop circuit to ensure that operation can be stopped and power switched off immediately.
- Any person who is involved in disassembly and repair should be fully competent to do the work.
- The STOP key of the parameter unit is only valid for test run. Provide an emergency stop key independently of the STOP key. (MELSERVO-H series only)
- Before resetting an alarm, make sure that the run signal into the servo amplifier is off to prevent an accident. A sudden restart is made if an alarm is reset with the run signal on.
- Do not modify the equipment.
- Use a noise filter, etc. to minimize the influence of electromagnetic interference, which may be caused by electronic equipment used near the servo amplifier.
- Burning or breaking a servo amplifier may cause a toxic gas. Do not burn or break a servo amplifier.
- Use the servo amplifier with the specified servo motor.
- The electromagnetic brake on the servo motor is designed to hold the servo motor shaft and should not be used for ordinary braking.
- For such reasons as service life and mechanical structure (e.g. where a ball screw and the servo motor are coupled via a timing belt), the electromagnetic brake may not hold the servo motor shaft. To ensure safety, install a stopper on the machine side.

(5) Corrective actions

⚠ CAUTION

- When it is assumed that a hazardous condition may take place at the occur due to a power failure or a product fault, use a servo motor with electromagnetic brake or an external brake mechanism for the purpose of prevention.
- Configure the electromagnetic brake circuit so that it is activated not only by the servo amplifier signals but also by an external emergency (forced) stop signal.

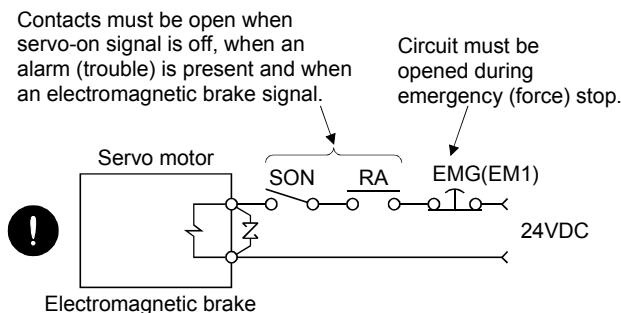

- When any alarm has occurred, eliminate its cause, ensure safety, and deactivate the alarm before restarting operation.
- When power is restored after an instantaneous power failure, keep away from the machine because the machine may be restarted suddenly (design the machine so that it is secured against hazard if restarted).

(6) Maintenance, inspection and parts replacement

 CAUTION

- With age, the electrolytic capacitor of the servo amplifier will deteriorate. To prevent a secondary accident due to a fault, it is recommended to replace the electrolytic capacitor every 10 years when used in general environment.
Please consult our sales representative.

(7) Storage

 CAUTION

Note the following points when storing the servo motor for an extended period of time (guideline: three or more months).

- Always store the servo motor indoors in a clean and dry place.
- If it is stored in a dusty or damp place, make adequate provision, e.g. cover the whole product.
- If the insulation resistance of the winding decreases, reexamine the storage method.
- Though the servo motor is rust-proofed before shipment using paint or rust prevention oil, rust may be produced depending on the storage conditions or storage period.
If the servo motor is to be stored for longer than six months, apply rust prevention oil again especially to the machined surfaces of the shaft, etc.
- Before using the product after storage for an extended period of time, hand-turn the motor output shaft to confirm that nothing is wrong with the servo motor. (When the servo motor is equipped with a brake, make the above check after releasing the brake with the brake power supply.)
- When the equipment has been stored for an extended period of time, consult Mitsubishi.

(8) General instruction

 CAUTION

- To illustrate details, the equipment in the diagrams of this Instruction Manual may have been drawn without covers and safety guards. When the equipment is operated, the covers and safety guards must be installed as specified. Operation must be performed in accordance with this Instruction Manual.

● About processing of waste ●

When you discard servo amplifier, a battery (primary battery), and other option articles, please follow the law of each country (area).

FOR MAXIMUM SAFETY

- These products have been manufactured as a general-purpose part for general industries, and have not been designed or manufactured to be incorporated in a device or system used in purposes related to human life.
- Before using the products for special purposes such as nuclear power, electric power, aerospace, medicine, passenger movement vehicles or under water relays, contact Mitsubishi.
- These products have been manufactured under strict quality control. However, when installing the product where major accidents or losses could occur if the product fails, install appropriate backup or failsafe functions in the system.

EEPROM life

The number of write times to the EEPROM, which stores parameter settings, etc., is limited to 100,000. If the total number of the following operations exceeds 100,000, the servo amplifier and/or converter unit may fail when the EEPROM reaches the end of its useful life.

- Write to the EEPROM due to parameter setting changes
- Write to the EEPROM due to device changes

Precautions for Choosing the Products

Mitsubishi will not be held liable for damage caused by factors found not to be the cause of Mitsubishi; machine damage or lost profits caused by faults in the Mitsubishi products; damage, secondary damage, accident compensation caused by special factors unpredictable by Mitsubishi; damages to products other than Mitsubishi products; and to other duties.

COMPLIANCE WITH EC DIRECTIVES

1. WHAT ARE EC DIRECTIVES?

The EC Directives were issued to standardize the regulations of the EU countries and ensure smooth distribution of safety-guaranteed products. In the EU countries, the Machinery Directive (effective in January, 1995), EMC Directive (effective in January, 1996) and Low Voltage Directive (effective in January, 1997) of the EC Directives require that products to be sold should meet their fundamental safety requirements and carry the CE marks (CE marking). CE marking applies to machines and equipment into which servo amplifiers have been installed.

The servo amplifiers do not function independently but are designed for use with machines and equipment.

Therefore, the CE marking does not apply to the servo amplifiers but applies to the machines and equipment into which the servo amplifiers are installed.

This servo amplifier conforms to the standards related to the Low Voltage Directive to facilitate CE marking on machines and equipment into which the servo amplifiers will be installed. To ensure ease of compliance with the EMC Directive, Mitsubishi Electric prepared the "EMC INSTALLATION GUIDELINES" (IB(NA)67310) which provides servo amplifier installation, control box making and other procedures. Please contact your sales representative.

2. PRECAUTIONS FOR COMPLIANCE

Use the servo motor compatible with the EN Standard.

Unless otherwise specified, the handling, performance, specifications and others of the EN Standard-compatible models are the same as those of the standard models.

To comply with the EN Standard, also observe the following items strictly.

(1) Wiring

- (a) Use a fixed terminal block to connect the power supply lead of the servo motor to the servo amplifier. Do not connect cables directly.

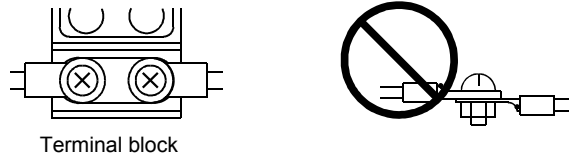

Terminal block

- (b) Use the servo motor side power connector which complies with the EN Standard. The EN Standard-compliant power connector sets are available from us as options.

Power Connector Set Model	Servo Motor Model
MR-PWCNF	HC-FF□C(B)-UE
MR-PWCNS1	HC-SF81(B) HC-SF52(B) to 152(B) HC-SF53(B) to 153(B) HC-RF103(B) to 203(B) HC-UF72(B) · 152(B) HC-SFS81(B) HC-SFS52(B) to 152(B) HC-SFS53(B) to 153(B) HC-SFS524(B) to 1524(B) HC-RFS103(B) to 203(B) HC-UFS72(B) · 152(B) HC-LFS52(B) to 152(B)
MR-PWCNS2	HC-SF121(B) to 301(B) HC-SF202(B) to 502(B) HC-SF203(B) · 353(B) HC-RF353(B) · 503(B) HC-UF202(B) to 502(B) HC-SFS121(B) to 301(B) HC-SFS202(B) to 502(B) HC-SFS203(B) · 353(B) HC-SFS2024(B) to 5024(B) HC-RFS353(B) · 503(B) HC-UFS202(B) to 502(B) HA-LFS502 HC-LFS202(B) · 302(B)
MR-PWCNS3	HC-SF702(B) · HC-SFS702(B) HC-SFS7024(B) HA-LFS702

(2) Installation

The flange of the machine mounted with the HC-MF(HC-MF-UE)/HC-KF(HC-KF-UE)/HC-AQ/HC-MFS/HC-KFS must be connected to the earth (⊕).

(3) Performing EMC tests

When EMC tests are run on a machine/device into which the servo motor has been installed, it must conform to the electromagnetic compatibility (immunity/emission) standards after it has satisfied the operating environment/electrical equipment specifications.

For the other EMC directive guidelines on the servo motor, refer to the EMC Installation Guidelines (IB(NA)67310).

CONFORMANCE WITH UL/C-UL STANDARD

Use the UL/C-UL Standard-compliant model of servo motor.

Unless otherwise specified, the handling, performance, specifications, etc. of the UL/C-UL Standard-compliant models are the same as those of the standard models.

The servo motor is compliant with the UL/C-UL standard when it is mounted on the flanges made of aluminum whose sizes are indicated in the following table.

The rated torque of the servo motor under the UL/C-UL standard indicates the continuous permissible torque value that can be generated when it is mounted on the flange specified in this table and used in the environment of 0°C to 40°C ambient temperature. Therefore, to conform to the UL/C-UL standard, mount the servo motor on a flange with a heat radiating effect equivalent to that of this flange.

Flange Size [mm]	Servo Motor								
	HC-KF(-UE) HC-KFS	HC-MF(-UE) HC-MFS	HA-FF□C -UE	(Note 2) HC-SF HC-SFS	HC-RF HC-RFS	HC-UF HC-UFS	HA-LF HA-LFS	HC-LFS	HC-AQ
150 × 150 × 3									0135 to 0335
150 × 150 × 6	053 · 13	053 · 13	053 · 13			13			
250 × 250 × 6	23	23	23 · 33			23			
250 × 250 × 12	43	43	43 · 63	81 52 to 152 53 to 153 524 to 1524	103 to 203	43		52 to 152	
300 × 300 × 12	(Note 1) 73	73				73			
300 × 300 × 20				121 · 201 202 · 352 203 · 353 2024 · 3524				202 · 302	
550 × 550 × 30					353 · 503	72 · 152			
650 × 650 × 35				301 502 · 702 5024 · 7024		202 to 502	601 to 12K1 701M to 15K1M 502 to 22K2 6014 to 12K14 701M4 to 15K1M4 11K24 to 22K24		
950 × 950 × 35							15K1 to 37K1 22K1M to 37K1M 30K2 · 37K2 15K14 to 37K14 22K1M4 to 50K1M4 30K24 to 55K24		

Note 1. 73 is not available for the HC-KF(-UE) series.

2. 524 to 7024 are not available for the HC-SF series.

CONTENTS

1. INTRODUCTION	1 - 1 to 1-16
1.1 Servo motor features	1 - 1
1.2 Model name make-up	1 - 2
1.3 Parts identification	1 -15
2. INSTALLATION	2 - 1 to 2-14
2.1 Environmental conditions.....	2 - 2
2.2 Installation orientation	2 - 4
2.3 Load remove precautions	2 - 4
2.4 Permissible load for the shaft.....	2 - 5
2.4.1 Without reduction gear	2 - 5
2.4.2 With reduction gear	2 - 7
2.5 Protection from oil and water.....	2 -11
2.6 Cooling fan.....	2 -13
2.7 Cable	2 -13
3. CONNECTORS USED FOR SERVO MOTOR WIRING	3 - 1 to 3-20
3.1 Makeups	3 - 1
3.1.1 HC-KF(-UE) • HC-MF(-UE) • HA-FF • HC-UF3000r/min series	3 - 1
3.1.2 HA-FF□C-UE series	3 - 1
3.1.3 HC-SF(S) • HC-RF(S) • HC-UF(S)2000r/min, HA-LH • HA-LF • HA-LFS • HC-LFS series.....	3 - 7
3.1.4 HC-AQ series.....	3 -15
3.1.5 HC-KFS • HC-MFS • HC-UFS3000r/min series	3 -15
3.1.6 HC-UF3000r/min series (Compliance with IP65)	3 -16
3.2 IP65, EN Standard-compliant options	3 -17
3.3 Signal arrangement of encoder connectors	3 -19
4. INSPECTION	4 - 1 to 4 - 2
5. SPECIFICATIONS	5 - 1 to 5-50
5.1 Standard specifications	5 - 1
5.2 Torque characteristics.....	5 -23
5.3 Servo motors with reduction gears	5 -41
5.4 Servo motors with special shafts.....	5 -47
5.4.1 Keyway.....	5 -47
5.4.2 D cut	5 -49
5.4.3 Straight (HC-AQ).....	5 -49
6. CHARACTERISTICS	6 - 1 to 6 - 6
6.1 Electromagnetic brake characteristics	6 - 1
6.2 Vibration rank.....	6 - 5
6.3 Machine accuracies.....	6 - 6

7. OUTLINE DIMENSION DRAWINGS	7 - 1 to 7 -306
--------------------------------------	------------------------

7.1 Servo motors.....	7 - 1
7.1.1 HC-MF • HC-KF series.....	7 - 1
7.1.2 HA-FF series	7 -23
7.1.3 HC-SF • HC-SFS series	7 -50
7.1.4 HC-RF • HC-RFS series	7 -90
7.1.5 HC-UF 2000r/min • HC-UFS 2000r/min series	7 -97
7.1.6 HC-UF 3000r/min series	7 -100
7.1.7 HC-UF3000r/min, HC-UFS3000r/min series with IP65-compliant connectors	7 -103
7.1.8 HA-LH series.....	7 -106
7.1.9 HC-AQ series.....	7 -108
7.1.10 HA-LF series	7 -109
7.1.11 HC-MFS • HC-KFS series	7 -113
7.1.12 HC-UFS 3000r/min series.....	7 -132
7.1.13 HA-LFS series.....	7 -135
7.1.14 HC-LFS series.....	7 -144
7.2 Servo motors (in inches).....	7 -149
7.2.1 HC-MF • HC-KF series.....	7 -149
7.2.2 HA-FF series	7 -171
7.2.3 HC-SF • HC-SFS series	7 -198
7.2.4 HC-RF • HC-RFS series	7 -238
7.2.5 HC-UF 2000r/min • HC-UFS 2000r/min series	7 -245
7.2.6 HC-UF 3000r/min series	7 -248
7.2.7 HC-UF3000r/min, HC-UFS3000r/min series with IP65-compliant connectors	7 -251
7.2.8 HA-LH series.....	7 -254
7.2.9 HC-AQ series.....	7 -256
7.2.10 HA-LF series	7 -257
7.2.11 HC-MFS • HC-KFS series	7 -261
7.2.12 HC-UFS 3000r/min series.....	7 -280
7.2.13 HA-LFS series.....	7 -283
7.2.14 HC-LFS series.....	7 -292
7.3 Connector.....	7 -297

8. CALCULATION METHODS FOR DESIGNING	8 - 1 to 8 -14
---	-----------------------

8.1 Specification symbol list.....	8 - 1
8.2 Position resolution and electronic gear setting	8 - 2
8.3 Speed and command pulse frequency.....	8 - 3
8.4 Stopping characteristics.....	8 - 4
8.5 Capacity selection.....	8 - 5
8.6 Load torque equations.....	8 - 8
8.7 Expression for calculating the electromagnetic brake workload.....	8 - 8
8.8 Load inertia moment equations	8 - 9
8.9 Precautions for zeroing	8 -10
8.10 Selection example	8 -11

App. 1 Servo motor ID codes..... App.- 1
App. 2 Change of connector sets to the RoHS compatible products App.- 3

1. INTRODUCTION

1. INTRODUCTION

1.1 Servo motor features

Servo Motor Series	Features (Points Different from Conventional Products)	Rated Speed [r/min]	Positioning Resolution [pulses/rev]	Capacity [kW]	Interchangeable Servo Motor Series	Compliance with Overseas Standards	Environmental Resistance
HC-KF	Low inertia, small capacity 4 to 5 times greater in inertia moment than HC-MF(S). Equipped with absolute position detector as standard	3000	8192	0.05 to 0.4	HC-MF HC-ME HC-MH	EN Standard UL/C-UL Standard (Standard model is compliant)	(Note1・2) IP44
HC-KFS			131072				(Note1・2) IP55
HC-MF	Ultra low inertia, small capacity 1.2 times higher in power rate than HA-ME Equipped with absolute position detector as standard	3000	8192	0.05 to 0.75	HA-ME HA-MH	EN Standard UL/C-UL Standard (Standard model is compliant)	(Note1・2) IP44
HC-MFS			131072				(Note1・2) IP55
HA-FF	Low inertia, small capacity Equipped with absolute position detector as standard	8192	3000	0.05 to 0.6	HA-FE HA-FH	EN Standard UL/C-UL Standard (HA-FF-UE is compliant)	(Note1・2) IP44
HC-SF	Middle inertia, middle capacity 1.5 times higher in power rate than HA-SE Equipped with absolute position detector as standard	1000 2000 3000	16384	0.5 to 7	HA-SE HA-SH	EN Standard UL/C-UL (Standard model is compliant)	IP65
HC-SFS	Three-phase, 200VAC-compatible Middle inertia, middle capacity 1.5 times higher in power rate than HA-SE Equipped with absolute position detector as standard	1000 2000 3000	131072	0.5 to 7	HA-SE HA-SH	EN Standard UL/C-UL (Standard model is compliant)	IP65
	Three-phase, 400VAC-compatible Middle inertia, middle capacity Equipped with absolute position detector as standard	2000					
HC-RF	Ultra low inertia, middle capacity About 3 times higher in power rate than HA-LH Equipped with absolute position detector as standard	3000	16384	1 to 5	/	EN Standard UL/C-UL Standard (Standard model is compliant)	IP65
HC-RFS			131072				
HC-UF	Flat type, small capacity Equipped with absolute position detector as standard	3000	8192	0.1 to 0.75	/	EN Standard UL/C-UL Standard (Standard model is compliant)	(Note1) IP65
	Flat type, middle capacity Equipped with absolute position detector as standard	2000	16384	0.75 to 5			IP65
HC-UFS	Flat type small capacity Equipped with absolute position detector as standard	3000	131072	0.1 to 0.75	/	EN Standard UL/C-UL Standard (Standard model is compliant)	(Note1) IP65
	Flat type middle capacity Equipped with absolute position detector as standard	2000		0.75 to 5			IP65
HA-LH	Low inertia, large capacity	2000	16384	11 to 22	/	EN Standard (HA-LH-EC is compliant)	JP44
HC-AQ	24VDC-compatible, compact size, small capacity	3000	8192	0.01 to 0.03	/	EN Standard, UL/C-UL Standard (Standard model is compliant)	(Note1・2) IP55
HA-LF	Three-phase, 200VAC-compatible, low inertia, large capacity Equipped with absolute position detector as standard	2000	16384	30・37	/	/	IP44
	Three-phase, 400VAC-compatible, low inertia, large capacity Equipped with absolute position detector as standard			30 to 55			
HA-LFS	Three-phase, 200VAC-compatible, low inertia, middle large capacity Equipped with absolute position detector as standard	1000	131072	6 to 37	/	EN Standard, UL/C-UL Standard (Standard model is compliant)	IP44
		1500		7 to 37			
		2000		5 to 37			
	Three-phase, 400VAC-compatible, low inertia, large capacity Equipped with absolute position detector as standard	1000		6 to 37			
		1500		7 to 50			
		2000		11 to 55			
HA-LH	Low inertia, middle capacity Equipped with absolute position detector as standard	2000	131072	0.5 to 3	HA-LH	EN Standard, UL/C-UL Standard (Standard model is compliant)	IP65

Note 1. Except connector section.
2. Except for the shaft-through portion.

1. INTRODUCTION

1.2 Model name make-up

(1) Rating plate

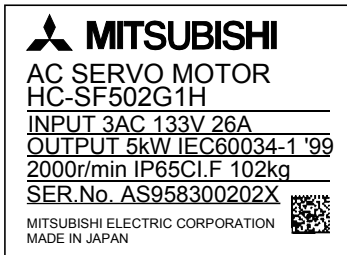

- Model
- Input power
- Rated output
- Rated speed, Protection structure, Insulation class, Mass
- Serial number

(2) Model

(a) HC-MF series (ultra low inertia, small capacity)

HC-MF □ 3 □ □ □ □
Series name

Compliance with Standard

Symbol	Specifications
None	(Note) Standard model (EN•UL/C-UL Standard)
-UE	EN • UL/C-UL Standard

Note. The standard models produced in and after February, 2001 are compatible with the EN•UL/C-UL Standard.

Appearance

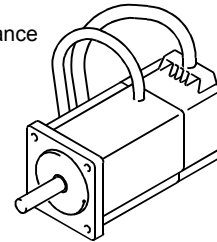

Shaft type

Symbol	Shaft Shape	HC-MF□
None	Standard (Straight shaft)	053 to 73
(Note) K	With keyway (With key)	23 to 73
(Note) D	D-cut shaft	53•13

Note. The special shaft applies to the standard servo motor and servo motor with electromagnetic brake.

Reduction gear

Symbol	Reduction Gear
None	Without
G1	For general industrial machine
G2	For precision application

Electromagnetic brake

Symbol	Electromagnetic Brake
None	Without
B	With

Rated speed
3000 [r/min]

Rated output

Symbol	Rated Output [kW]
05	0.05
1	0.1
2	0.2
4	0.4
7	0.75

1. INTRODUCTION

(b) HA-FF series (low inertia, small capacity)

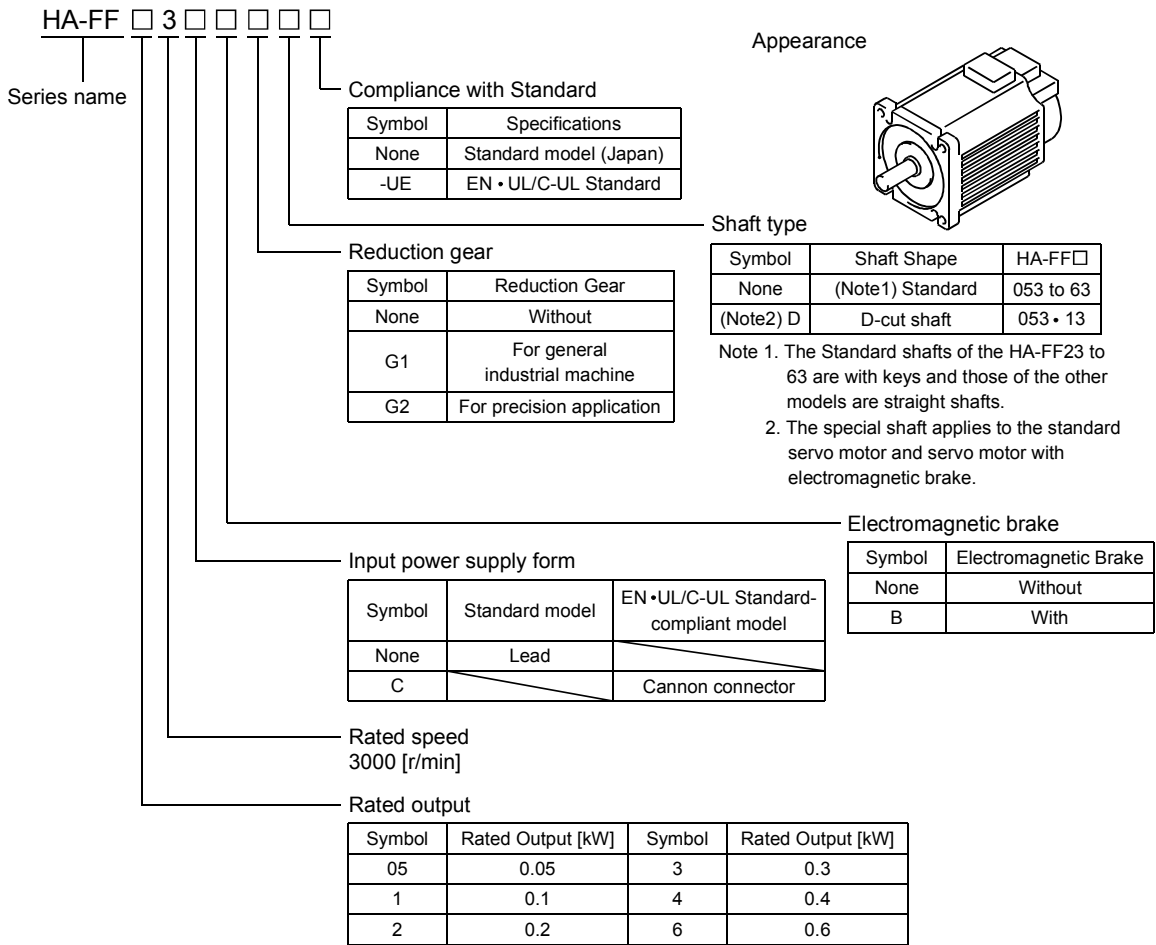

1. INTRODUCTION

(c) HC-SF series (middle inertia, middle capacity)

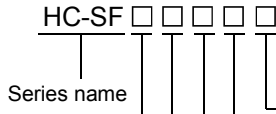

Shaft type

Symbol	Shaft Shape
None	Standard (Straight shaft)
(Note) K	With keyway (With key)

Note. The special shaft applies to the standard servo motor and servo motor with electromagnetic brake.

Reduction gear

Symbol	(Note) Reduction Gear
None	Without
G1	For general industrial machine (flange type)
G1H	For general industrial machine (leg type)
G2	For precision application

Note. Not provided for 1000r/min and 3000r/min series.

Rated speed

Symbol	Speed [r/min]
1	1000
2	2000
3	3000

Electromagnetic brake

Symbol	Electromagnetic Brake
None	Without
B	With

Rated output

Symbol	Rated Output [kW]	1000 [r/min]	2000 [r/min]	3000 [r/min]
5	0.5	○	○	○
8	0.85	○	○	○
10	1	○	○	○
12	1.2	○	○	○
15	1.5	○	○	○
20	2	○	○	○
30	3	○	○	○
35	3.5	○	○	○
50	5	○	○	○
70	7	○	○	○

Appearance

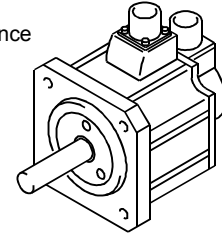

1. INTRODUCTION

(d) HC-RF series (ultra low inertia, middle capacity)

HC-RF □ 3 □ □ □

Series name

Shaft type

Symbol	Shaft Shape
None	Standard (Straight shaft)
(Note) K	With keyway (With key)

Note. The special shaft applies to the standard servo motor and servo motor with electromagnetic brake.

Reduction gear

Symbol	Reduction Gear
None	Without
G2	For precision application

Rated speed 3000 [r/min]

Rated output

Symbol	Rated Output [kW]
10	1
15	1.5
20	2
35	3.5
50	5

Electromagnetic brake

Symbol	Electromagnetic Brake
None	Without
B	With

Appearance

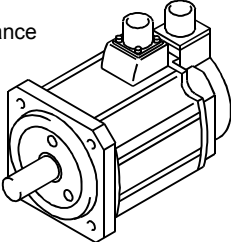

(e) HC-UF series (flat type, small and middle capacity)

HC-UF □ □ □ □

Series name

Shaft type

Symbol	Shaft Shape	HC-UF□
None	Standard (Straight shaft)	13 to 43 72 to 202
(Note) K	With keyway (HC-UF23 to 73: With key)	
(Note) D	D-cut shaft	13

Note. The special shaft applies to the standard servo motor and servo motor with electromagnetic brake.

Rated speed

Symbol	Speed [r/min]
2	2000
3	3000

Rated output

Symbol	Rated Output [kW]
1	0.1
2	0.2
4	0.4
7	0.75
15	1.5
20	2
35	3.5
50	5

Electromagnetic brake

Symbol	Electromagnetic Brake
None	Without
B	With

Appearance

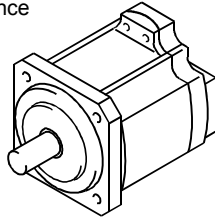

1. INTRODUCTION

(f) HA-LH series (low inertia, large capacity)

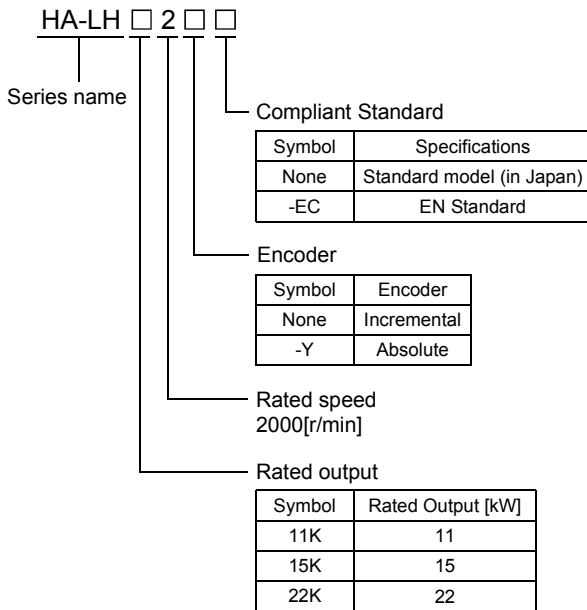

Appearance

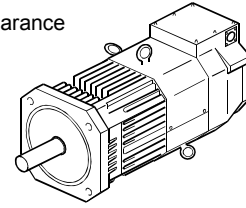

(g) HC-KF series (low inertia, small capacity)

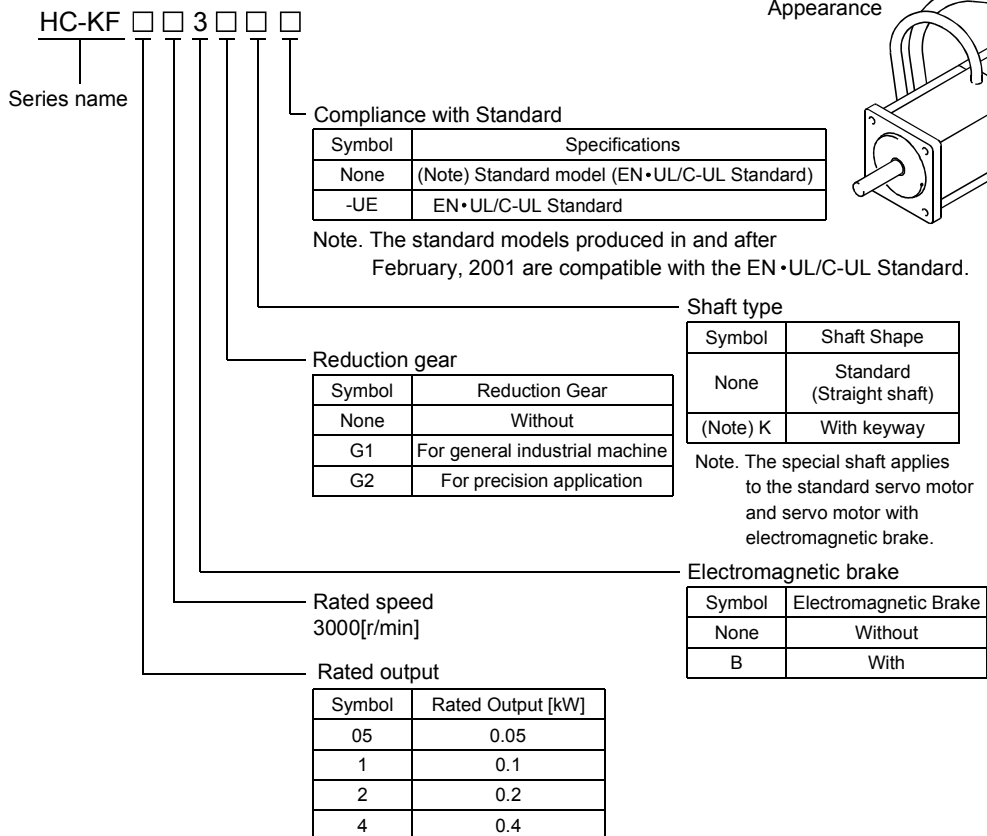

Appearance

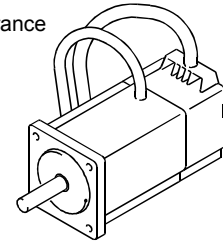

1. INTRODUCTION

(h) HC-AQ series (24VDC-compatible, compact size, small capacity)

HC-AQ □ 3 5 □ □

Series name

Shaft type

Symbol	Shaft Shape
(Note) D	D-cut shaft
(Note) S	Straight shaft

Note. The special shaft applies to the standard servo motor and servo motor with electromagnetic brake.

Electromagnetic brake

Symbol	Electromagnetic Brake
None	Without
B	With

Power supply voltage
24VDC

Rated speed
3000 [r/min]

Rated output

Symbol	Rated Output [kW]
01	0.01
02	0.02
03	0.03

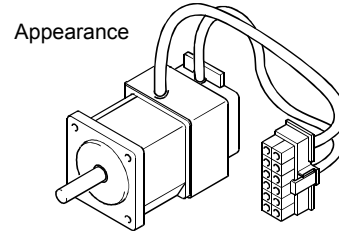

(i) HA-LF series (Three-phase, 200 • 400VAC-compatible, low inertia, large capacity)

HA-LF □ 2 □

Series name

Power supply specification

Symbol	Power Supply Voltage
None	Three-phase 200 to 230VAC
4	Three-phase 380 to 480VAC

Rated speed
2000 [r/min]

Rated output

Symbol	Rated Output [kW]	Power supply specifications	
		Three-phase 200 to 230VAC	Three-phase 380 to 480VAC
30K	30	○	○
37K	37	○	○
45K	45	○	○
55K	55	○	○

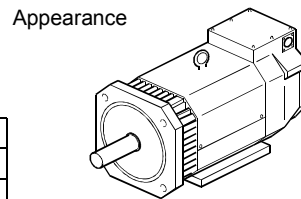

1. INTRODUCTION

(j) HC-KFS series (low inertia, small capacity, high resolution)

HC-KFS □ 3 □ □ □

Series name

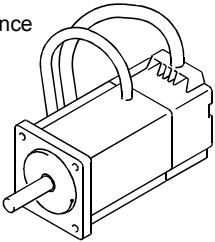
Appearance 

Shaft type

Symbol	Shaft Shape	HC-KFS□
None	Standard (Straight shaft)	053 to 73
(Note) K	With keyway (With key)	23 to 73
(Note) D	D-cut shaft	053•13

Note. The special shaft applies to the standard servo motor and servo motor with electromagnetic brake.

Reduction gear

Symbol	Reduction Gear
None	Without
G1	For general industrial machine
G2	For precision application

Rated speed 3000[r/min]

Rated output

Symbol	Rated Output [kW]
05	0.05
1	0.1
2	0.2
4	0.4

Electromagnetic brake

Symbol	Electromagnetic Brake
None	Without
B	With

(k) HC-MFS series (ultra low inertia, small capacity, high resolution)

HC-MFS □ 3 □ □ □

Series name

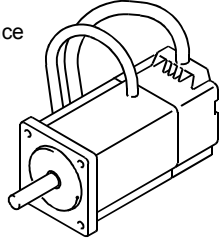
Appearance 

Shaft type

Symbol	Shaft Shape	HC-MFS□
None	Standard (Straight shaft)	053 to 73
(Note) K	With keyway (With key)	23 to 73
(Note) D	D-cut shaft	53•13

Note. The special shaft applies to the standard servo motor and servo motor with electromagnetic brake.

Reduction gear

Symbol	Reduction Gear
None	Without
G1	For general industrial machine
G2	For precision application

Rated speed 3000 [r/min]

Rated output

Symbol	Rated Output [kW]
05	0.05
1	0.1
2	0.2
4	0.4
7	0.75

Electromagnetic brake

Symbol	Electromagnetic Brake
None	Without
B	With

1. INTRODUCTION

- (l) HC-SFS series (middle inertia, middle capacity, high resolution)
 1) 200VAC-compatible

HC-SFS □ □ □ □
 |
 Series name

Shaft type

Symbol	Shaft Shape
None	Standard (Straight shaft)
(Note) K	With keyway (Without key)

Note. The special shaft applies to the standard servo motor and servo motor with electromagnetic brake.

Reduction gear

Symbol	Reduction Gear
None	Without
G1	(Note) For general industrial machine (flange type)
G1H	(Note) For general industrial machine (leg type)
G2	(Note) For precision application

Note. Not provided for 1000r/min and 3000r/min series.

Rated speed

Symbol	Speed [r/min]
1	1000
2	2000
3	3000

Electromagnetic brake

Symbol	Electromagnetic Brake
None	Without
B	With

Rated output

Symbol	Rated Output [kW]	1000 [r/min]	2000 [r/min]	3000 [r/min]
5	0.5	○	○	○
8	0.85	○	○	○
10	1	○	○	○
12	1.2	○	○	○
15	1.5	○	○	○
20	2	○	○	○
30	3	○	○	○
35	3.5	○	○	○
50	5	○	○	○
70	7	○	○	○

Appearance

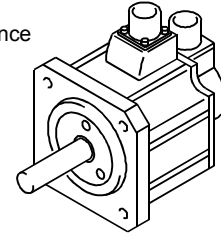

1. INTRODUCTION

2) 400VAC-compatible

HC-SFS □ 2 4 □ □ □

Series name

Shaft type

Symbol	Shaft Shape
None	Standard (Straight shaft)
(Note) K	With keyway (Without key)

Note. The special shaft applies to the standard servo motor and servo motor with electromagnetic brake.

Electromagnetic brake

Symbol	Electromagnetic brake
None	Without
B	With

Power supply voltage
Three-phase 380 to 480 VAC

Rated speed
2000 [r/min]

Rated output

Symbol	Rated output [kW]
5	0.5
10	1
15	1.5
20	2
35	3.5
50	5
70	7

Appearance

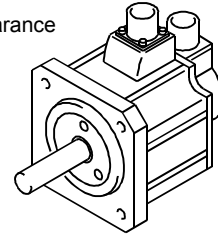

Reductiongear

Symbol	Reductiongear
None	Without
G1	For general industrial machine (flange type)
G1H	For general industrial machine (leg type)
G2	For precision application

1. INTRODUCTION

(m) HC-RFS series (ultra low inertia, middle capacity, high resolution)

HC-RFS □ 3 □ □ □

Series name

Shaft type

Symbol	Shaft Shape
None	Standard (Straight shaft)
(Note) K	With keyway (Without key)

Note. The special shaft applies to the standard servo motor and servo motor with electromagnetic brake.

Reduction gear

Symbol	Reduction Gear
None	Without
G2	For precision application

Rated speed
3000 [r/min]

Rated output

Symbol	Rated Output [kW]
10	1
15	1.5
20	2
35	3.5
50	5

Electromagnetic brake

Symbol	Electromagnetic Brake
None	Without
B	With

Appearance

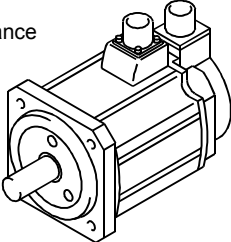

(n) HC-UFS series (flat type small and middle capacity, high resolution)

HC-UFS □ □ □ □

Series name

Shaft type

Symbol	Shaft Shape	HC-UFS□
None	Standard (Straight shaft)	13 to 43
(Note) K	With keyway HC-UFS 23 to 73 are provided with keys.	72 to 202
(Note) D	D-cut shaft	13

Note. The special shaft applies to the standard servo motor and servo motor with electromagnetic brake.

Rated speed

Symbol	Speed [r/min]
2	2000
3	3000

Rated output

Symbol	Rated Output [kW]
1	0.1
2	0.2
4	0.4
7	0.75
15	1.5
20	2
35	3.5
50	5

Electromagnetic brake

Symbol	Electromagnetic Brake
None	Without
B	With

Appearance

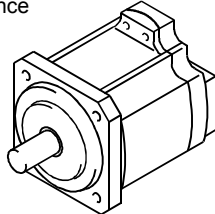

1. INTRODUCTION

- (o) HA-LFS series (low inertia, middle large capacity, high resolution)
 1) 200VAC-compatible

HA-LFS □ □ □ □

Series name

Shaft type

Symbol	Shaft Shape
None	Standard (Straight shaft)
(Note) K	With keyway (Without key)

Note. The special shaft applies to the standard servo motor and servo motor with electromagnetic brake.

Electromagnetic brake

Symbol	Electromagnetic brake
Note	Without
(Note)B	For precision application

Note. Refer to Table 6.1 for the servo motor compatible with the electromagnetic brake.

Rated speed

Symbol	Speed [r/min]
1	1000
1M	1500
2	2000

Rated output

Symbol	Rated Output [kW]	1000 [r/min]	1500 [r/min]	2000 [r/min]
50	5			○
60	6	○		
70	7		○	○
80	8	○		
11K	11		○	○
12K	12	○		
15K	15	○	○	○
20K	20	○		
22K	22		○	○
25K	25	○		
30K	30	○	○	○
37K	37	○	○	○

Appearance

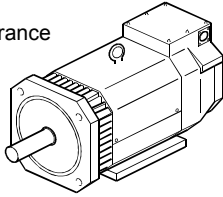

1. INTRODUCTION

2) 400VAC-compatible

HA-LFS □ □ 4 □ □
Series name

Shaft type

Symbol	Shaft Shape
None	Standard (Straight shaft)
(Note) K	With keyway (Without key)

Note. The special shaft applies to the standard servo motor and servo motor with electromagnetic brake.

Electromagnetic brake

Symbol	Electromagnetic brake
Note	Without
(Note)B	For precision application

Note. Refer to Table 6.1 for the servo motor compatible with the electromagnetic brake.

Power supply voltage
Three-phase 380 to 480 VAC

Rated speed

Symbol	Speed [r/min]
1	1000
1M	1500
2	2000

Rated output

Symbol	Rated Output [kW]	1000 [r/min]	1500 [r/min]	2000 [r/min]
60	6	○	△	△
70	7	△	○	△
80	8	○	△	△
11K	11	△	○	○
12K	12	○	△	△
15K	15	○	○	○
20K	20	○	△	△
22K	22	△	○	○
25K	25	○	△	△
30K	30	○	○	○
37K	37	○	○	○
45K	45	△	○	○
50K	50	△	○	△
55K	55	△	△	○

Appearance

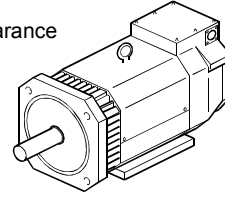

1. INTRODUCTION

(p) HC-LFS series (low inertia, middle capacity, high resolution)

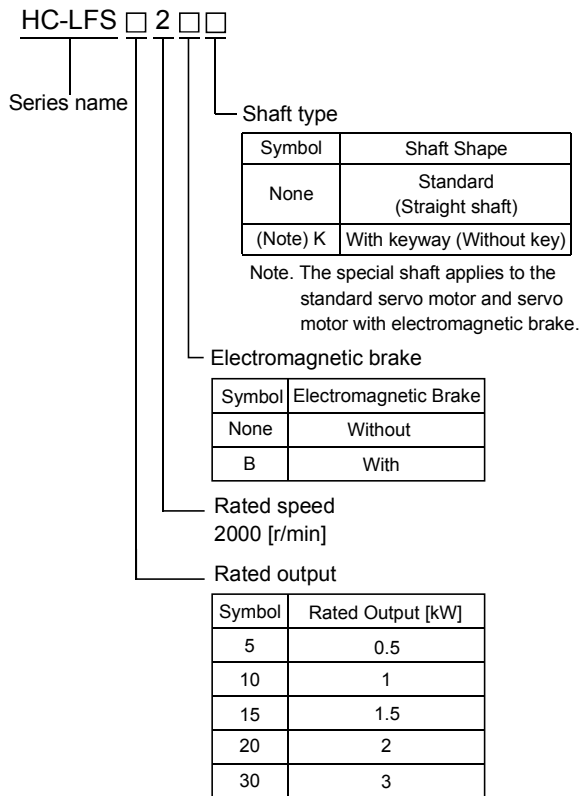

Appearance

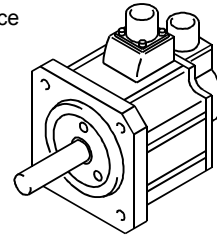

1. INTRODUCTION

1.3 Parts identification

Lead type

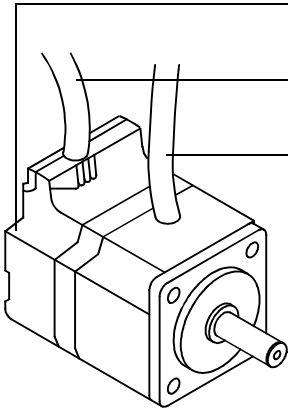

Name/Application	Reference
Encoder	Section 5.1
Encoder cable with encoder connector	Section 3.2
Power cable <ul style="list-style-type: none"> • Power lead (U·V·W) • Earth lead • Brake lead (for motor with electromagnetic brake) 	Chapter 7
Servo motor shaft	Chapter 2 Section 5.4

Connector type

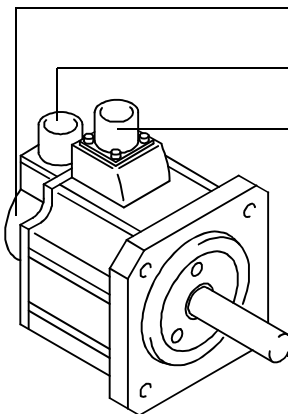

Name/Application	Reference
Encoder	Section 5.1
Encoder connector	Section 3.2
Power connector <ul style="list-style-type: none"> • Power supply (U·V·W) • Earth (⊕) • Brake (for motor with electromagnetic brake) Some motors with electromagnetic brakes have brake connectors separately.	Chapter 7
Servo motor shaft	Chapter 2 Section 5.4

Terminal box type

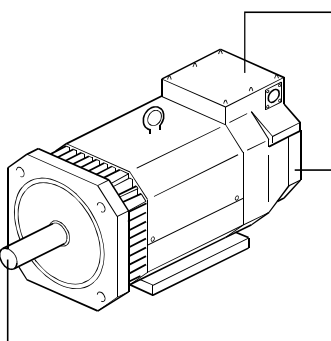

Name/Application	Reference
Terminal box <ul style="list-style-type: none"> • Power leads (U·V·W) • Cooling fan leads • Ground terminal • Brake lead (for motor with electromagnetic brake) 	Chapter 7
Encoder connector	Section 3.2
Encoder	Section 5.1
Servo motor shaft	Chapter 2

MEMO

2. INSTALLATION

2. INSTALLATION



- Stacking in excess of the limited number of products is not allowed.
- Install the equipment on incombustible material. Installing them directly or close to combustibles will lead to a fire.
- Install the equipment in a load-bearing place in accordance with this Instruction Manual.
- Do not get on or put heavy load on the equipment to prevent injury.
- Use the equipment within the specified environmental condition range.
- Do not subject the servo motor to drop impact or shock loads as they are precision equipment.
- Do not install or operate a faulty servo amplifier.
- Do not hold the cable, shaft or encoder to carry the servo motor. Otherwise, a fault or injury may occur.
- The lifting eyebolts of the servo motor may only be used to transport the servo motor. They must not be used to transport the servo motor when it is mounted on a machine.
- The servo motor with reduction gear must be installed in the specified direction. Otherwise, it can leak oil, leading to a fire or fault.
- Securely fix the servo motor to the machine. If fixed insecurely, the servo motor will come off during operation, leading to injury.
- When coupling the shaft end of the servo motor, do not subject the shaft end to impact, such as hammering. The encoder may become faulty.
- When coupling a load to the servo motor, do not use a rigid coupling. Doing so can cause the shaft to break.
- Take safety measures, e.g. provide covers, to prevent accidental access to the rotating parts of the servo motor during operation.
- Do not subject the servo motor shaft to more than the permissible load. Otherwise, the shaft may break, leading to injury.
- When the product has been stored for an extended period of time, consult Mitsubishi.
- When treating the servo motor, be careful about the edged parts such as the corners of the servo motor.

2. INSTALLATION

2.1 Environmental conditions

Environment			Conditions	
Ambient temperature	In Operation	[°C]	0 to +40 (non-freezing)	
		[°F]	32 to 104 (non-freezing)	
	In Storage	[°C]	-15 to 70 (non-freezing)	
		[°F]	5 to 158 (non-freezing)	
Ambient humidity	In Operation	80%RH or less (non-condensing)		
	In Storage	90%RH or less (non-condensing)		
Ambience			Indoors (no direct sunlight) Free from corrosive gas, flammable gas, oil mist, dust and dirt	
Altitude			Max. 1000m (3280 ft) above sea level	
(Note) Vibration	[m/s ²]	HC-KFS series HC-MFS series	HC-UFS13 to 73	X,Y:49
		HC-SFS81 HC-SFS52 to 152 HC-SFS53 to 153	HC-SFS524 to 1524 HC-RFS series HC-UFS72 • 152	X,Y:24.5
		HC-SFS121 • 201 HC-SFS202 • 352 HC-SFS203 • 353	HC-SFS2024 • 3524 HC-UFS202 to 502	X:24.5 Y:49
		HC-SFS301 HC-SFS502 • 702	HC-SFS5024 • 7024	X:24.5 Y:29.4
		HC-AQ series HC-KF series HC-MF series	HA-FF series HC-UF13 to 73	X,Y:19.6
		HC-SF81 HC-SF52 to 152 HC-SF53 to 153	HC-RF series HC-UF72 • 152 HC-LFS52 to152	X:9.8 Y:24.5
		HC-SF121 • 201 HC-SF202 • 352 HC-SF203 • 353	HC-UF202 to 502 HC-LFS202 • 302	X:19.6 Y:49
		HA-LFS601 to12K1 HA-LFS701M to 15K1M HA-LFS502 to 22K2 HA-LFS6014 to 12K14 HA-LFS701M4 to 15K1M4 HA-LFS11K24 to 22K24	HA-LH11K2 to 22K2 HC-SF301 HC-SF502 • 702	X:11.7 Y:29.4
	HA-LFS15K1 to 37K1 HA-LFS22K1M to 37K1M HA-LFS30K2 • 37K2 HA-LFS15K14 to 37K14 HA-LFS22K1M4 to 50K1M4 HA-LFS30K24 to 55K24	HA-LF series	X,Y:9.8	
	[ft/s ²]	HC-KFS series HC-MFS series	HC-UFS13 to 73	X,Y:161
		HC-SFS81 HC-SFS52 to 152 HC-SFS53 to 153	HC-SFS524 to 1524 HC-RFS series HC-UFS72 • 152	X,Y:80
		HC-SFS121 • 201 HC-SFS202 • 352 HC-SFS203 • 353	HC-SFS2024 • 3524 HC-UFS202 to 502	X:80 Y:161
		HC-SFS301 HC-SFS502 • 702	HC-SFS5024 • 7024	X:80 Y:96
		HC-AQ series HC-KF series HC-MF series	HA-FF series HC-UF13 to 73	X,Y:64
		HC-SF81 HC-SF52 to 152 HC-SF53 to 153	HC-RF series HC-UF72 • 152 HC-LFS52 to152	X:32 Y:80
		HC-SF121 • 201 HC-SF202 • 352 HC-SF203 • 353	HC-UF202 to 502 HC-LFS202 • 302	X:64 Y:161
HA-LFS601 to12K1 HA-LFS701M to 15K1M HA-LFS502 to 22K2 HA-LFS6014 to 12K14 HA-LFS701M4 to 15K1M4 HA-LFS11K24 to 22K24		HA-LH11K2 to 22K2 HC-SF301 HC-SF502 • 702	X:38.4 Y:96.5	
HA-LFS15K1 to 37K1 HA-LFS22K1M to 37K1M HA-LFS30K2 • 37K2 HA-LFS15K14 to 37K14 HA-LFS22K1M4 to 50K1M4 HA-LFS30K24 to 55K24	HA-LF series	X,Y:32		

Note. Except the servo motor with reduction gear.

2. INSTALLATION

Vibration occurs in the directions shown below. The values were measured at the portion which indicates the maximum value (normally the bracket opposite to load side). When the servo motor is at a stop, the bearings are likely to fret and vibration should therefore be suppressed to about half of the permissible value.

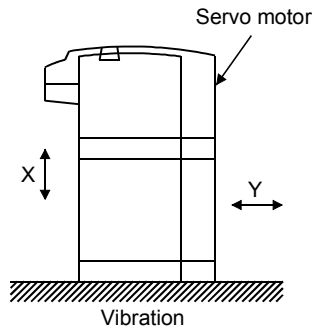

Graph of vibration servo amplitude vs. speed

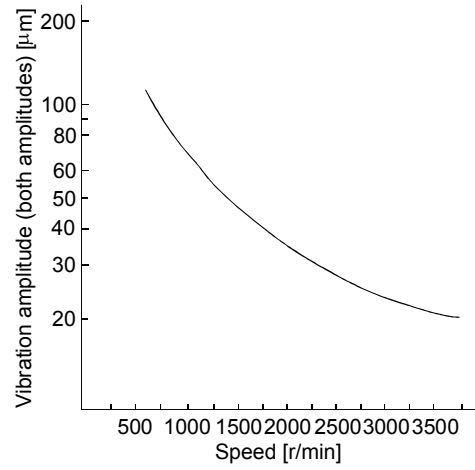

2. INSTALLATION

2.2 Installation orientation

The following table lists directions of installation.

Servo Motor Series	Direction of Installation	Remarks
HC-KF HC-MF HA-FF HC-SF HC-RF HC-UF HC-KFS HC-MFS HC-SFS HC-RFS HC-UFS HC-LFS	May be installed in any direction.	For installation in the horizontal direction, it is recommended to set the connector section downward.
HC-AQ HA-LH HA-LFS (Flange type)		
HA-LF HA-LFS (Flange - leg type)	Horizontal direction with the legs downward.	Use either the legs or flange for installation.

When the servo motor with electromagnetic brake is installed with the shaft end at top, the brake plate may generate sliding sound but it is not a fault. Refer to section 5.3 for the installation orientation of the servo motor with reduction gear.

2.3 Load remove precautions

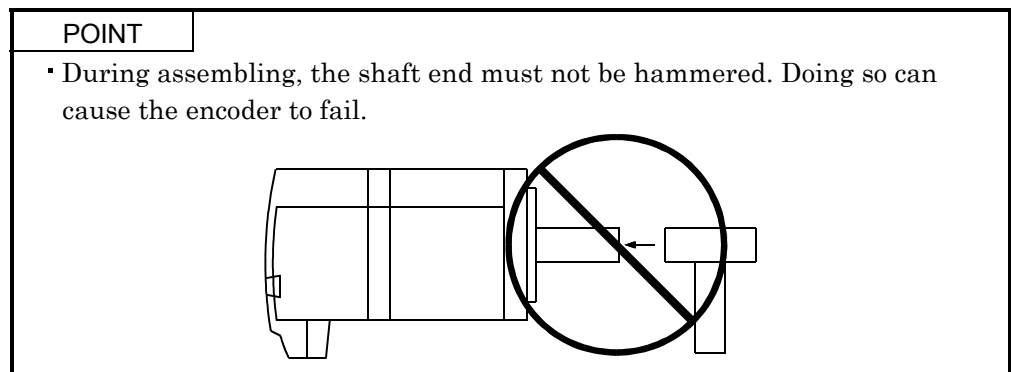

- When mounting a pulley to the servo motor shaft provided with a keyway, use the screw hole in the shaft end. To fit the pulley, first insert a double-end stud into the screw hole of the shaft, put a washer against the end face of the coupling, and insert and tighten a nut to force the pulley in.

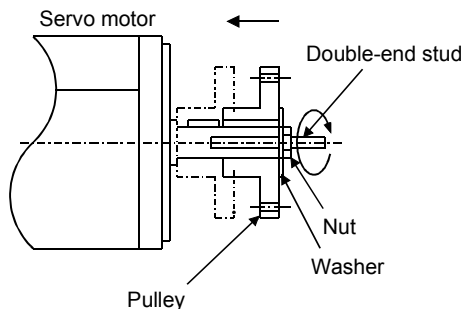

- For the servo motor shaft with a keyway, use the screw hole in the shaft end. For the shaft without a keyway, use a friction coupling or the like.
- When removing the pulley, use a pulley remover to protect the shaft from impact.
- To ensure safety, fit a protective cover or the like on the rotary area, such as the pulley, mounted to the shaft.
- When a threaded shaft end part is needed to mount a pulley on the shaft, please contact us.
- The orientation of the encoder on the servo motor cannot be changed.
- For installation of the servo motor, use spring washers, etc. and fully tighten the bolts so that they do not become loose due to vibration.
- For the HC-AQ series, use spring washers and apply Screw Lock to mount the servo motor. In addition, use Helisert screws when the flange for mounting the servo motor is made of aluminum.

2. INSTALLATION

2.4 Permissible load for the shaft

POINT
<ul style="list-style-type: none"> Do not use a rigid coupling as it may apply excessive bending load to the shaft, leading to shaft breakage.

- Use a flexible coupling and make sure that the misalignment of the shaft is less than the permissible radial load.
- When using a pulley, sprocket or timing belt, select a diameter that will fit into the permissible radial load.
- Excess of the permissible load can cause the bearing life to reduce and the shaft to break.
- The load indicated in this section is static load in a single direction and does not include eccentric load. Make eccentric load as small as possible. Not doing so can cause the servo motor to be damaged.

2.4.1 Without reduction gear

Servo Motor		L (Note 1)		Permissible Radial Load (Note 2)		Permissible Thrust Load (Note 2)	
		[mm]	[in]	[N]	[lb]	[N]	[lb]
HC-KF HC-KFS	053 / 13	25	0.98	88	20	59	13
	23 / 43	30	1.18	245	55	98	22
	73 (Note 3)	40	1.57	392	88	147	33
HC-MF HC-MFS	053 / 13	25	0.98	88	20	59	13
	23 / 43	30	1.18	245	55	98	22
	73	40	1.57	392	88	147	33
HA-FF	053	30	1.18	108	24	98	22
	13	30	1.18	118	27	98	22
	23 / 33	30	1.18	176	40	147	33
	43 / 63	40	1.57	323	73	284	64
HC-SF HC-SFS	81	55	2.17	980	220	490	110
	121 to 301	79	3.11	2058	463	980	220
	52 (4) to 152 (4) (Note4)	55	2.17	980	220	490	110
	202 (4) / 702 (4) (Note4)	79	3.11	2058	463	980	220
	53 to 153	55	2.17	980	220	490	110
	203 / 353	79	3.11	2058	463	980	220
HC-LFS	52 to 152	55	2.17	980	220	490	110
	202/302	79	3.11	2058	463	980	220
HC-RF HC-RFS	103 to 203	45	1.77	686	154	196	44
	353 / 503	63	2.48	980	220	392	88
HC-UF HC-UFS	72 / 152	55	2.17	637	143	490	110
	202	65	2.56	882	198	784	176
	352 / 502	65	2.56	1176	264	784	176
	13	25	0.98	88	20	59	13
	23 / 43	30	1.18	245	55	98	22
	73	40	1.57	392	88	147	33
HA-LH	11K2	85	3.35	2450	551	980	220
	15K2/22K2	110	4.33	2940	661	980	220
HC-AQ	0135	16	0.63	34	8	14	3
	0235	16	0.63	44	10	14	3
	0335	16	0.63	49	11	14	3
HA-LF	30K2(4) • 37K2(4)	140	5.51	3234	727	1470	330
	45K24 /55K24	140	5.51	4900	1102	1960	441
HA-LFS	502/702/601(4)/701M(4)/11K2(4)	85	3.35	2450	551	980	153
	801(4) • 12K1(4) • 11K1M(4) • 15K1M(4) • 15K2(4) • 22K2(4)	110	4.33	2940	661	980	153
	15K1(4) • 20K1(4) • 22K1M(4) • 30K1M(4) • 30K2(4) • 37K2(4)	140	5.51	3234	727	1470	330
	25K1(4) • 30K1(4) • 37K1M(4) • 45K1M4 • 45K24 • 55K24	140	5.51	4900	1102	1960	441
	37K1(4) • 50K1M4	170	6.69	6370	1432	1960	441

2. INSTALLATION

Note 1. For the symbols in the table, refer to the following diagram.

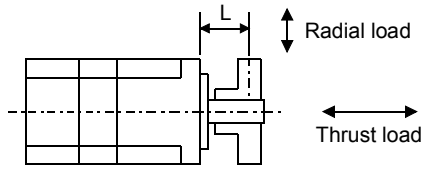

L: Distance from flange mounting surface to load center

2. Do not subject the shaft to load greater than this value. The values in the table assume that the loads work singly.
3. 73 is not available for the HC-KF series.
4. 524 to 7024 are not available for the HC-SF series.

2. INSTALLATION

2.4.2 With reduction gear

The permissible radial loads in the table are the values at the center of the reduction gear output shaft.

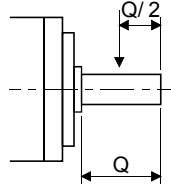

(1) HC-MF • HC-MFS • HC-KF • HC-KFS series

(a) General industrial machine-compliant

Item	Gear ratio	HC-MF053(B)G1	HC-MF13(B)G1	HC-MF23(B)G1	HC-MF43(B)G1	HC-MF73(B)G1	
		HC-MFS053(B)G1	HC-MFS13(B)G1	HC-MFS23(B)G1	HC-MFS43(B)G1	HC-MFS73(B)G1	
		HC-KF053(B)G1	HC-KF13(B)G1	HC-KF23(B)G1	HC-KF43(B)G1	HC-KFS73(B)G1	
		HC-KFS053(B)G1	HC-KFS13(B)G1	HC-KFS23(B)G1	HC-KFS43(B)G1		
Permissible Radial Load	[N]	1/5	150		330		430
		1/12	240		710		620
		1/20	370		780	760	970
	[lb]	1/5	34		74		97
		1/12	54		160		139
		1/20	83		175	171	218
Permissible Thrust Load	[N]	1/5	200		350		430
		1/12	320		720		620
		1/20	450		780	760	960
	[lb]	1/5	45		79		97
		1/12	72		162		139
		1/20	101		175	171	216

(b) Precision application-compliant

Item	Gear ratio	HC-MF053(B)G2	HC-MF13(B)G2	HC-MF23(B)G2	HC-MF43(B)G2	HC-MF73(B)G2	
		HC-MFS053(B)G2	HC-MFS13(B)G2	HC-MFS23(B)G2	HC-MFS43(B)G2	HC-MFS73(B)G2	
		HC-KF053(B)G2	HC-KF13(B)G2	HC-KF23(B)G2	HC-KF43(B)G2	HC-KFS73(B)G2	
		HC-KFS053(B)G2	HC-KFS13(B)G2	HC-KFS23(B)G2	HC-KFS43(B)G2		
Permissible Radial Load	[N]	1/5	160	160	160	340	390
		1/9	200	200	420	480	600
		1/20	260	540	610	790	1040
		1/29	290	610	700	900	1190
	[lb]	1/5	36	36	36	76	88
		1/9	45	45	94	108	135
		1/20	58	121	137	178	234
		1/29	65	137	157	202	268
Permissible Thrust Load	[N]	1/5	220	220	220	370	390
		1/9	270	270	450	490	600
		1/20	400	660	640	790	1140
		1/29	450	750	830	1010	1290
	[lb]	1/5	49	49	49	83	87
		1/9	61	61	101	110	135
		1/20	90	148	144	178	256
		1/29	101	167	187	227	290

2. INSTALLATION

(2) HA-FF series

(a) General industrial machine-compliant

Item		Gear ratio	HA-FF053(B)G1	HA-FF13(B)G1	HA-FF23(B)G1	HA-FF33(B)G1	HA-FF43(B)G1	HA-FF63(B)G1
Permissible Radial Load	[N]	1/5	588		686		686	980
		1/10	588		686		686	1470
		1/20	588		1176		1568	1764
		1/30	686		1225		1764	2156
	[lb]	1/5	132		154		154	220
		1/10	132		154		154	330
		1/20	132		264		353	397
		1/30	154		275		397	485

(b) Precision application-compliant

Item		Gear ratio	HA-FF053(B)G2	HA-FF13(B)G2	HA-FF23(B)G2	HA-FF33(B)G2	HA-FF43(B)G2	HA-FF63(B)G2
Permissible Radial Load	[N]	1/5	69	69	98	216	216	588
		1/9					735	735
		1/10	88	127	265	265		
		1/15	137	216	392			
		1/20			980	980	1274	1274
		1/25	392	784				
		1/29			1078	1470	1470	1470
	1/45		1274	1666	1666	1666	3430	
	[lb]	1/5	15	15	22	49	49	132
		1/9					165	165
		1/10	20	29	60	60		
		1/15	31	49	88			
		1/20			220	220	286	286
		1/25	88	176				
1/29				242	330	330	330	
1/45		286	375	375	375	771		
Permissible Thrust Load	[N]	1/5	59	59	147	265	265	784
		1/9					980	980
		1/10	78	167	343	343		
		1/15	88	216	363			
		1/20			1372	1372	2254	2254
		1/25	314	412				
		1/29			1764	2548	2548	2548
	1/45		1960	3234	3234	3234	5390	
	[lb]	1/5	13	13	33	60	60	176
		1/9					220	220
		1/10	16	38	77	77		
		1/15	20	49	82			
		1/20			308	308	507	507
		1/25	71	93				
1/29				397	573	573	573	
1/45		441	727	727	727	1212		

2. INSTALLATION

(3) HC-SF • HC-SFS (2000r/min) series

(a) General industrial machine-compliant

Item	Gear ratio	HC-SF52(B)G1	HC-SF102(B)G1	HC-SF152(B)G1	HC-SF202(B)G1	HC-SF352(B)G1	HC-SF502(B)G1	HC-SF702(B)G1
		HC-SFS52(B)G1	HC-SFS102(B)G1	HC-SFS152(B)G1	HC-SFS202(B)G1	HC-SFS352(B)G1	HC-SFS502(B)G1	HC-SFS702(B)G1
		HC-SFS524(B)G1	HC-SFS1024(B)G1	HC-SFS1524(B)G1	HC-SFS2024(B)G1	HC-SFS3524(B)G1	HC-SFS5024(B)G1	HC-SFS7024(B)G1
Permissible Radial Load	[N]	1/6	2058	2842	2842	2842	3332	
		1/11	2391	3273	3273	3273	3871	5488
		1/17	2832	3646	3646	3646	4420	6468
		1/29	3273	4410	5135	7291	7291	13426
		1/35	5253	5253	6047	8555	8555	16072
		1/43	5253	6047	8555	8555	11662	16072
	[lb]	1/59	5880	9741	9741	9741	13132	
		1/6	463	639	639	639	749	
		1/11	538	728	728	728	870	1234
		1/17	637	820	820	820	994	1454
		1/29	728	991	1154	1639	1639	3018
		1/35	1181	1181	1359	1923	1923	3613
		1/43	1181	1359	1923	1923	2622	3613
		1/59	1322	2190	2190	2190	2952	
Permissible Thrust Load	[N]	1/6	1470	2352	2352	2352	3920	
		1/11	1470	2764	2764	2764	3920	6292
		1/17	1470	2940	2940	2940	3920	6860
		1/29	1470	2940	3920	6860	6860	13720
		1/35	2940	2940	3920	6860	6860	13720
		1/43	2940	3920	6860	6860	9800	13720
	[lb]	1/59	2940	6860	6860	6860	9800	
		1/6	330	529	529	529	881	
		1/11	330	621	621	621	881	1415
		1/17	330	661	661	661	881	1542
		1/29	330	661	881	1542	1542	3084
		1/35	661	661	881	1542	1542	3084
		1/43	661	881	1542	1542	2203	3084
		1/59	661	1542	1542	1542	2203	

2. INSTALLATION

(b) Precision application-compliant

Item	Gear ratio	HC-SF52(B)G2	HC-SF102(B)G2	HC-SF152(B)G2	HC-SF202(B)G2	HC-SF352(B)G2	HC-SF502(B)G2	HC-SF702(B)G2	
		HC-SFS52(B)G2 HC-SFS524(B)G2	HC-SFS102(B)G2 HC-SFS1024(B)G2	HC-SFS152(B)G2 HC-SFS1524(B)G2	HC-SFS202(B)G2 HC-SFS2024(B)G2	HC-SFS352(B)G2 HC-SFS3524(B)G2	HC-SFS502(B)G2 HC-SFS5024(B)G2	HC-SFS702(B)G2 HC-SFS7024(B)G2	
Permissible Radial Load	[N]	1/5	833	833	833	1666	3822	3822	3822
		1/9	980	980	1960	1960	4704	4704	
		1/20	1274	2646	2646	6076	6076		
		1/29	2940	2940	6860	6860			
		1/45	3430	8036	8036	8036			
	[lb]	1/5	187	187	187	375	859	859	859
		1/9	220	220	441	441	1058	1058	
		1/20	286	595	595	1366	1366		
		1/29	661	661	1542	1542			
		1/45	771	1807	1807	1807			
Permissible Thrust Load	[N]	1/5	1176	1176	1176	2156	5488	5488	5488
		1/9	1568	1568	2646	2646	7252	7252	
		1/20	2254	3724	3724	9506	9506		
		1/29	4704	4704	11760	11760			
		1/45	5390	14700	14700	14700			
	[lb]	1/5	264	264	264	485	1234	1234	1234
		1/9	353	353	595	595	1630	1630	
		1/20	507	837	837	2137	2137		
		1/29	1058	1058	2644	2644			
		1/45	1212	3305	3305	3305			

(4) HC-RF • HC-RFS series

Item	Gear ratio	HC-RF103(B)G2	HC-RF153(B)G2	HC-RF203(B)G2	HC-RF353(B)G2	HC-RF503(B)G2	
		HC-RFS103(B)G2	HC-RFS153(B)G2	HC-RFS203(B)G2	HC-RFS353(B)G2	HC-RFS503(B)G2	
Permissible Radial Load	[N]	1/5	833	833	833	1666	3822
		1/9	980	1960	1960	4704	4704
		1/20	2646	2646	2646	6076	6076
		1/29	2940	2940	6860	6860	
		1/45	3430	8036	8036		
	[lb]	1/5	187	187	187	375	859
		1/9	220	441	441	1058	1058
		1/20	595	595	595	1366	1366
		1/29	661	661	1542	1542	
		1/45	771	1806	1806		
Permissible Thrust Load	[N]	1/5	1176	1176	1176	2156	5488
		1/9	1568	2646	2646	7252	7252
		1/20	3724	3724	3724	9506	9506
		1/29	4704	4704	11760	11760	
		1/45	5390	14700	14700		
	[lb]	1/5	264	264	264	485	1234
		1/9	353	595	595	1630	1630
		1/20	837	837	837	2137	2137
		1/29	1058	1058	2644	2644	
		1/45	1212	3305	3305		

2. INSTALLATION

2.5 Protection from oil and water

- (1) Next, the servo motor is not waterproof (IP44). Do not subject the servo motor to oil and water. Especially for the HC-MF · HC-KF · HC-AQ · HC-KFS · HC-MFS and HA-FF series, do not subject the shaft-through portion to oil.

Servo Motor Series	Protection
HC-KF/HC-MF HA-LF/HA-FF/HA-LFS	IP44
HC-AQ/HC-KFS/HC-MFS	IP55
HA-LH	JP44

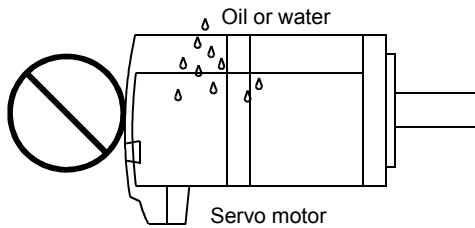

- (2) When the gear box is mounted horizontally, the oil level in the gear box should always be lower than the oil seal lip on the servo motor shaft. If it is higher than the oil seal lip, oil will enter the servo motor, leading to a fault.

The HC-MF · HC-KF · HC-AQ · HC-MFS and HC-KFS series servo motor is not equipped with an oil seal and cannot be used with the gear box as described above. Oil should be shut off on the gear box side.

In a special specification article with an oil seal is available. Please contact Mitsubishi.

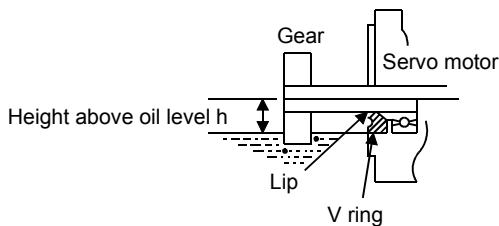

Servo Motor		Height above Oil Level h	
		[mm]	[in]
HC-SF	81	20	0.79
	121 to 301	25	0.98
	52(4) to 152(4) (Note)	20	0.79
	202(4) to 702(4) (Note)	25	0.98
	53 to 153	20	0.79
HC-SFS	203/353	25	0.98
	52 to 152	20	0.79
HC-LFS	202/302	25	0.98
HC-RF	103 to 503	20	0.79
		20	0.79
HC-RFS	103 to 503	20	0.79
		20	0.79
HC-UF	72/152	20	0.79
	202 to 502	25	0.98
	13	12	0.47
	23/43	14	0.55
	73	20	0.79

Servo Motor		Height above Oil Level h	
		[mm]	[in]
HA-FF	053/13	8	0.32
	23/33	12	0.47
	43/63	14	0.55
HA-LH	11K2	30	0.18
	15K2/22K2	40	1.58
HA-LF	30K2(4) · 37K2(4)	45	1.77
	45K24/55K24	48	1.89
HA-LFS	502 · 702 · 601(4) · 701M(4) · 11K2(4)	34	1.34
	15K1(4) · 20K1(4) · 22K1M(4) · 30K1M(4) · 30K2(4) · 37K2(4)	45	1.77
	801(4) · 12K1(4) · 25K1(4) · 30K1(4) · 11K1M(4) · 15K1M(4) · 37K1M(4) · 45K1M4 · 15K2(4) · 22K2(4) · 45K24 · 55K24	48	1.89
	37K1(4) · 50K1M4	55	2.17
	37K1(4) · 50K1M4	55	2.17

Note. 524 to 7024 are not available for the HC-SF series.

2. INSTALLATION

- (3) When installing the servo motor horizontally, face the power cable and encoder cable downward. When installing the servo motor vertically or obliquely, provide a trap for the cable.

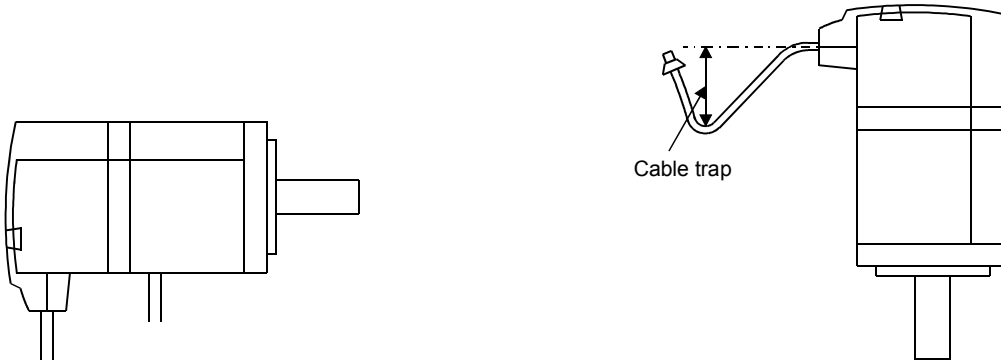

- (4) Do not use the servo motor with its cable soaked in oil or water. (Figure on the right)

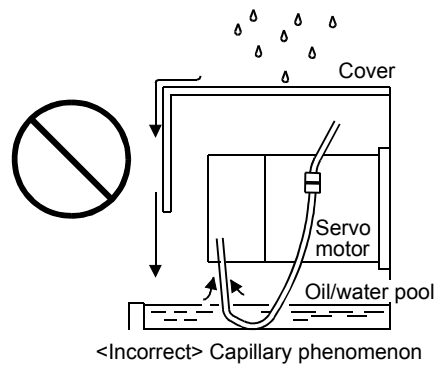

- (5) When the servo motor is to be installed with the shaft end at top, provide measures so that it is not exposed to oil and water entering from the machine side, gear box, etc.

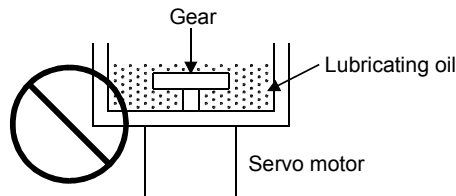

- (6) If the servo motor is exposed to oil such as coolant, the sealant, packing, cable and others may be affected depending on the oil type.
- (7) In the environment where the servo motor is exposed to oil mist, oil, water, grease and/or like, the servo motor of the standard specifications may not be usable. Contact us.
- (8) In the case of the servo motor with oil seal, the oil seal may sound during operation. It poses no problems in function.

2. INSTALLATION

2.6 Cooling fan

The HA-LH • HA-LF and HA-LFS servo motors have a cooling fan. Leave the following distance between the servo motor's suction face and the wall.

Servo Motor Series	Distance L	
	[mm]	[in]
HA-LH series	50	1.97
HA-LFS601 to 12K1 HA-LFS701M to 15K1M HA-LFS11K2 to 22K2 HA-LFS6014 to 12K14 HA-LFS701M4 to 15K1M4 HA-LFS11K24 to 22K24	100	3.94
HA-LF30K2/37K2 HA-LF30K24 to 55K24 HA-LFS15K1 to 37K1 HA-LFS22K1M to 37K1M HA-LFS30K2/37K2 HA-LFS15K14 to 37K14 HA-LFS22K1M4 to 50K1M4 HA-LFS30K24 to 55K24	150	5.91

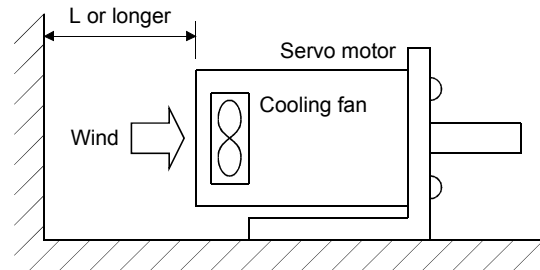

2.7 Cable

The power supply and encoder cables routed from the servo motor should be fixed to the servo motor to keep them unmovable. Otherwise, cable breaks may occur. In addition, do not modify the connectors, terminals and others at the ends of the cables.

3. CONNECTORS USED FOR SERVO MOTOR WIRING

3. CONNECTORS USED FOR SERVO MOTOR WIRING

POINT
<ul style="list-style-type: none"> Protective structure indicated for cables and connectors is for a cable or connector alone. When the cables and connectors are used to connect the servo amplifier and servo motor, and if protective structures of the servo amplifier and servo motor are lower than that of the cable and connector, specifications of the servo amplifier and servo motor apply.

3.1 Makeups

This section gives connector makeups on an operating environment basis. Use the models of the manufacturers given or equivalent.

3.1.1 HC-KF(-UE) · HC-MF(-UE) · HA-FF · HC-UF3000r/min series

Use round crimping terminals (1.25-4) for connection of the power supply and electromagnetic brake. For connection of the encoder, use the connector indicated in this section or equivalent. This connector may be used with the EN Standard and UL/C-UL Standard but is not waterproof.

Servo Motor	Connector Supplied for Servo Motor (Tyco Electronics)	Cable Side Connector		
		Housing (Tyco Electronics)	Connector Pin (Tyco Electronics)	Cable Clamp (Toa Electric Industry)
HC-KF□ (B) HC-KF□ (B)-UE HC-MF□ (B) HC-MF□ (B) -UE HA-FF□ (B) HC-UF13 to 73(B)	1-172169-9	1-172161-9	170359-1 170363-1 (loose piece)	MTI-0002

3.1.2 HA-FF□C-UE series

If used with a waterproof connector, the HA-FF□C(B)-UE does not improve in ingress protection (IP54).

(1) Non-waterproof, UL/C-UL Standard-compliant

(a) When using cabtyre cables

1) For connection of power supply

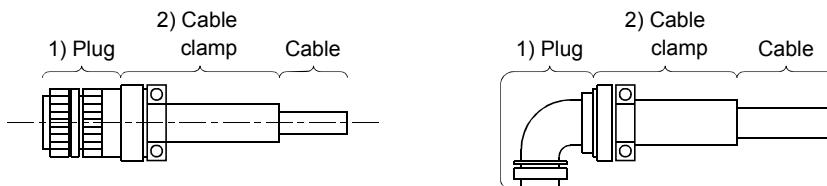

Servo Motor	Connector Supplied for Servo Motor	Cable Side Connector		
		1) Plug (DDK)		2) Cable clamp (DDK)
		Type	Model	
HA-FF□C(B) -UE	CE05-2A14S-2PD-B	Straight Angle	D/MS3106B14S-2S D/MS3108B14S-2S	D/MS3057-6A

3. CONNECTORS USED FOR SERVO MOTOR WIRING

2) For connection of encoder

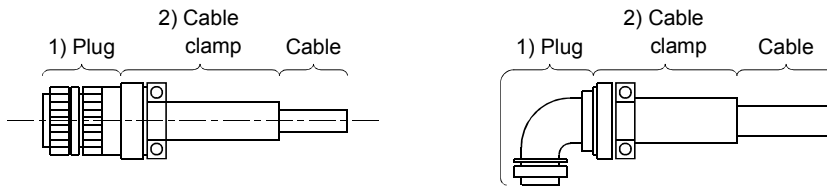

Servo Motor	Connector Supplied for Servo Motor	Cable Side Connector		
		1) Plug (DDK)		2) Cable clamp (DDK)
		Type	Model	
HA-FF□C(B) -UE	MS3102A20-29P	Straight	D/MS3106B20-29S	D/MS3057-12A
		Angle	D/MS3108B20-29S	

3) For connection of brake

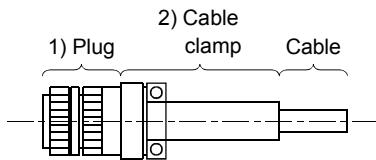

Servo Motor	Connector Supplied for Servo Motor	Cable Side Connector		
		Plug (DDK)		2) Cable clamp (DDK)
		Type	Model	
HA-FF□CB-UE	MS3102A10SL-4P	Straight	D/MS3106A10SL-4S	D/MS3057-4A

(b) When using flexible conduits

1) For connection of power supply

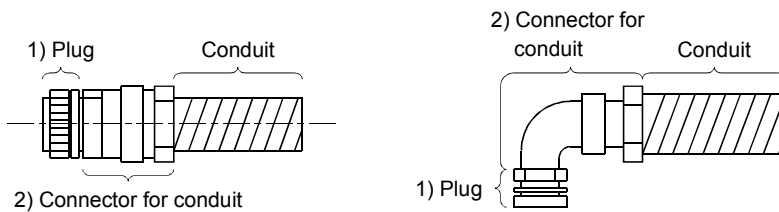

Servo Motor	Connector Supplied for Servo Motor	Cable Side Connector						
		1) Plug (DDK)	2) Cable Connector				Conduit	
			Type	Manufacturer	Size	Model	Model	ID
HA-FF□C(B) -UE	CE05-2A14S-2PD-B	D/MS3106A14S-2S(D190)	Straight	Nippon flex	1/4	RCC-102RL-MS14F	VF-02	8.3
					3/8	RCC-103RL-MS14F	VF-03	10.6
					1/2	RCC-104RL-MS14F	VF-04	14.0
				Daiwa Dengyo	10	MSA-10-14	FCV10	10.0
					12	MSA-12-14	FCV12	12.3
					Angle	Nippon flex	1/4	RCC-302RL-MS14F
			3/8	RCC-303RL-MS14F			VF-03	10.6
			1/2	RCC-304RL-MS14F			VF-04	14.0
			Daiwa Dengyo	10		MAA-10-14	FCV10	10.0
				12	MAA-12-14	FCV12	12.3	

3. CONNECTORS USED FOR SERVO MOTOR WIRING

2) For connection of encoder

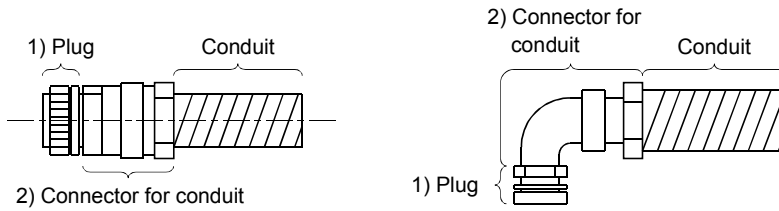

Servo Motor	Connector Supplied for Servo Motor	Cable Side Connector						
		1) Plug (DDK)	2) Cable Connector				Conduit	
			Type	Manufacturer	Size	Model	Model	ID
HA-FF□C(B)-UE	MS3102A20-29P	D/MS3106A20-29S(D190)	Straight	Nippon flex	1/2	RCC-104RL-MS20F	VF-04	14.0
					3/4	RCC-106RL-MS20F	VF-06	19.0
				Daiwa Dengyo	16	MSA-16-20	FCV16	15.8
					22	MSA-22-20	FCV22	20.8
			Angle	Nippon flex	1/2	RCC-304RL-MS20F	VF-04	14.0
					3/4	RCC-306RL-MS20F	VF-06	19.0
				Daiwa Dengyo	16	MAA-16-20	FCV16	15.8
					22	MAA-22-20	FCV22	20.8

3) For connection of brake

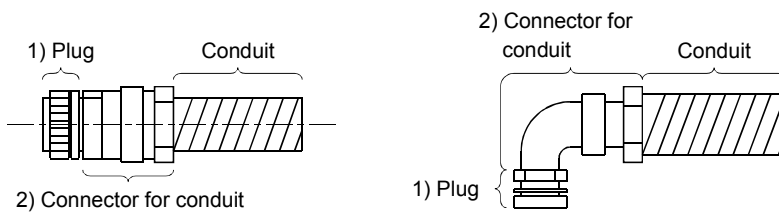

Servo Motor	Connector Supplied for Servo Motor	Cable Side Connector						
		1) Plug (DDK)	2) Cable Connector				Conduit	
			Type	Manufacturer	Size	Model	Model	ID
HA-FF□CB-UE	MS3102A10SL-4P	D/MS3106A10SL-4S(D190)	Straight	Nippon flex	1/4	RCC-102RL-MS10F	VF-02	8.3
				Daiwa Dengyo	10	MSA-10-10	FCV10	10.0
			Angle	Nippon flex	1/4	RCC-302RL-MS10F	VF-02	8.3
				Daiwa Dengyo	10	MAA-10-10	FCV10	10.0

3. CONNECTORS USED FOR SERVO MOTOR WIRING

(2) EN Standard, UL/C-UL Standard-compliant

(a) When using cabtyre cables

1) For connection of power supply

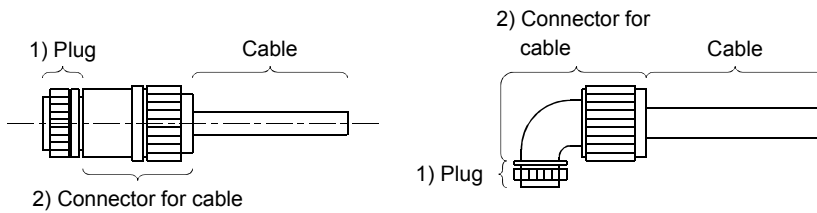

Servo Motor	Connector Supplied for Servo Motor	Cable Side Connector				
		1) Plug (DDK)	2) Connector for Cable			
			Type	Manufacturer	Cable OD	Model
HA-FF□C(B)-UE	CE05-2A14S-2PD-B	CE05-6A14S-2SD-D	Straight	Nippon flex	4 to 8	ACS-08RL-MS14F
					8 to 12	ACS-12RL-MS14F
				Daiwa Dengyo	5 to 8.3	YSO14-5 to 8
					8.3 to 11.3	YSO14-9 to 11
			Angle	Nippon flex	4 to 8	ACA-08RL-MS14F
					8 to 12	ACA-12RL-MS14F
Daiwa Dengyo	5 to 8.3	YLO14-5 to 8				
	8.3 to 11.3	YLO14-9 to 11				

2) For connection of encoder

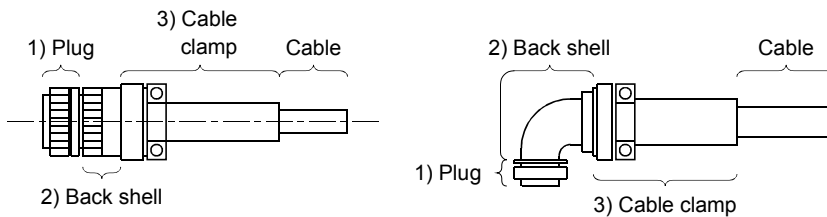

Servo Motor	Connector Supplied for Servo Motor	Cable Side Connector				
		1) Plug (DDK)	2) Back Shell (DDK)		3) Cable Clamp (DDK)	
			Type	Model	Cable OD	Model
HA-FF□C(B)-UE	MS3102A20-29P	D/MS3106A20-29S(D190)	Straight	CE02-20BS-S-D	6.8 to 10	CE3057-12A-3-D
			Angle	CE-20BA-S-D		

3. CONNECTORS USED FOR SERVO MOTOR WIRING

3) For connection of brake

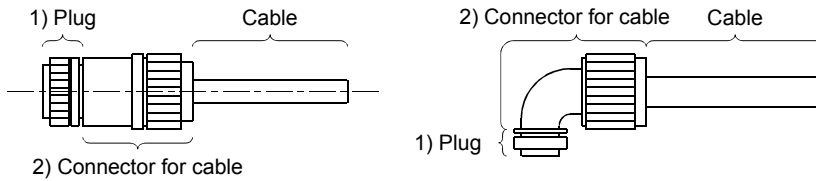

Servo Motor	Connector Supplied for Servo Motor	Cable Side Connector				
		1) Plug (DDK)	2) Cable Connector			
			Type	Manufacturer	Cable OD	Model
HA-FF□CB-UE	MS3102A10SL-4P	D/MS3106A10SL-4S(D190)	Straight	Nippon flex	4 to 8	ACS-08RL-MS10F
					8 to 12	ACS-12RL-MS10F
				Daiwa Dengyo	5 to 8.3	YS010-5 to 8
			Angle	Nippon flex	4 to 8	ACA-08RL-MS10F
					8 to 12	ACA-12RL-MS10F
				Daiwa Dengyo	5 to 8.3	YL010-5 to 8

(b) When using flexible conduits

1) For connection of power supply

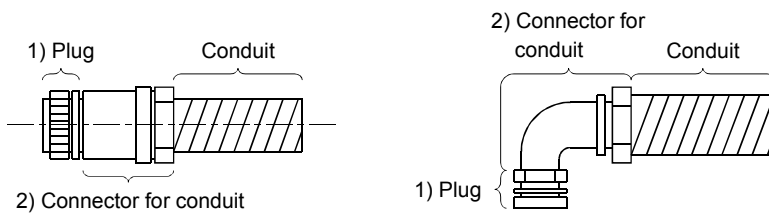

Servo Motor	Connector Supplied for Servo Motor	Cable Side Connector						
		1) Plug (DDK)	2) Cable Connector				Conduit	
			Type	Manufacturer	Size	Model	Model	ID
HA-FF□C(B)-UE	CE05-2A14S-2PD-B	CE05-6A14S-2SD-D	Straight	Nippon flex	1/4	RCC-102RL-MS14F	VF-02	8.3
					3/8	RCC-103RL-MS14F	VF-03	10.6
					1/2	RCC-104RL-MS14F	VF-04	14.0
				Daiwa Dengyo	10	MSA-10-14	FCV10	10.0
					12	MSA-12-14	FCV12	12.3
					Angle	Nippon flex	1/4	RCC-302RL-MS14F
			3/8	RCC-303RL-MS14F			VF-03	10.6
			1/2	RCC-304RL-MS14F			VF-04	14.0
			Daiwa Dengyo	10		MAA-10-14	FCV10	10.0
				12	MAA-12-14	FCV12	12.3	

3. CONNECTORS USED FOR SERVO MOTOR WIRING

2) For connection of encoder

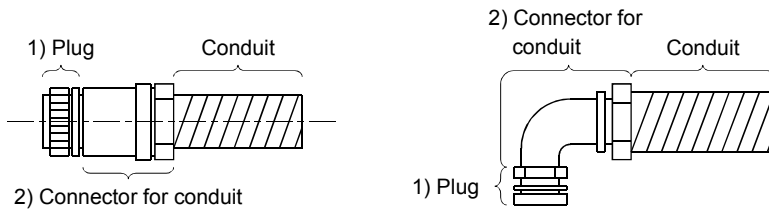

Servo Motor	Connector Supplied for Servo Motor	Cable Side Connector						
		1) Plug (DDK)	2) Cable Connector				Conduit	
			Type	Manufacturer	Size	Model	Model	ID
HA-FF□C(B)-UE	MS3102A20-29P	D/MS3106A20-29S(D190)	Straight	Nippon flex	1/2	RCC-104RL-MS20F	VF-04	14.0
					3/4	RCC-106RL-MS20F	VF-06	19.0
				Daiwa Dengyo	16	MSA-16-20	FCV16	15.8
					22	MSA-22-20	FCV22	20.8
			Angle	Nippon flex	1/2	RCC-304RL-MS20F	VF-04	14.0
					3/4	RCC-306RL-MS20F	VF-06	19.0
				Daiwa Dengyo	16	MAA-16-20	FCV16	15.8
					22	MAA-22-20	FCV22	20.8

3) For connection of brake

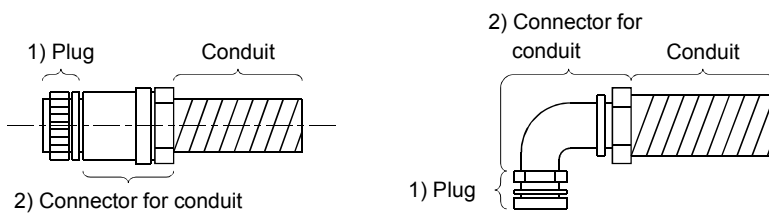

Servo Motor	Connector Supplied for Servo Motor	Cable Side Connector						
		1) Plug (DDK)	2) Cable Connector				Conduit	
			Type	Manufacturer	Size	Model	Model	ID
HA-FF□CB-UE	MS3102A10SL-4P	D/MS3106A10SL-4S(D190)	Straight	Nippon flex	1/4	RCC-102RL-MS10F	VF-02	8.3
				Daiwa Dengyo	10	MSA-10-10	FCV10	10.0
			Angle	Nippon flex	1/4	RCC-302RL-MS10F	VF-02	8.3
				Daiwa Dengyo	10	MAA-10-10	FCV10	10.0

3. CONNECTORS USED FOR SERVO MOTOR WIRING

3.1.3 HC-SF(S) • HC-RF(S) • HC-UF(S)2000r/min, HA-LH • HA-LF • HA-LFS • HC-LFS series

(1) Non-waterproof, UL/C-UL Standard-compliant

(a) When using cabtyre cables

1) For connection of power supply

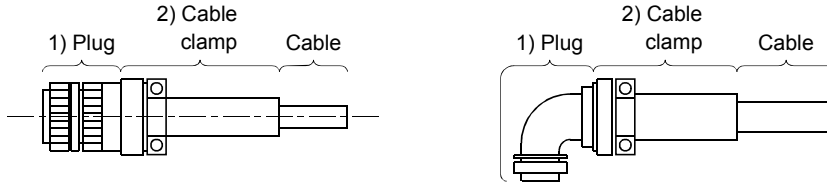

Servo Motor	Connector Supplied for Servo Motor	Cable Side Connector		
		1) Plug (DDK)		2) Cable clamp (DDK)
		Type	Model	
HC-SF81(B) HC-SF52(B) to 152(B) HC-SF53(B) to 153(B) HC-RF103(B) to 203(B) HC-UF72(B) • 152(B) HC-SFS81(B) HC-SFS52(B) to 152(B) HC-SFS53(B) to 153(B) HC-SFS524(B) to 1524(B) HC-RFS103(B) to 203(B) HC-UFS72(B) • 152(B) HC-LFS52(B) to 152(B)	CE05-2A22-23PD-B	Straight Angle	D/MS3106B22-23S D/MS3108B22-23S	D/MS3057-12A
HC-SF121(B) to 301(B) HC-SF202(B) to 502(B) HC-SF203(B) • 353(B) HC-RF353(B) to 503(B) HC-UF202(B) to 502(B) HC-SFS121(B) to 301(B) HC-SFS202(B) to 502(B) HC-SFS203(B) to 353(B) HC-SFS2024(B) to 5024(B) HC-RFS353(B) • 503(B) HC-UFS202(B) to 502(B) HA-LFS502 HC-LFS202(B) • 302(B)	CE05-2A24-10PD-B	Straight Angle	D/MS3106B24-10S D/MS3108B24-10S	D/MS3057-16A
HC-SF702(B) HC-SFS702(B) HC-SFS7024(B) HA-LFS702	CE05-2A32-17PD-B	Straight Angle	D/MS3106B32-17S D/MS3108B32-17S	D/MS3057-20A

3. CONNECTORS USED FOR SERVO MOTOR WIRING

2) For connection of encoder

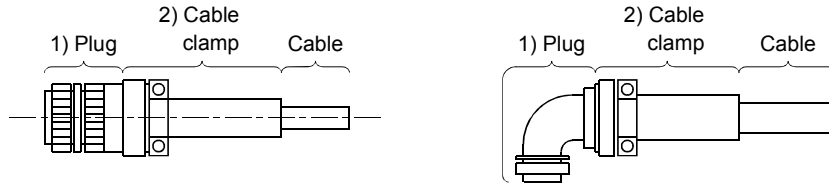

Servo Motor	Connector Supplied for Servo Motor	Cable Side Connector		
		1) Plug (DDK)		2) Cable clamp (DDK)
		Type	Model	
HC-SF81(B) to 301(B) HC-SF52(B) to 702(B) HC-SF53(B) to 353(B) HC-RF103(B) to 503(B) HC-UF72(B) to 502(B) HC-SFS81(B) to 301(B) HC-SFS52(B) to 702(B) HC-SFS53(B) to 353(B) HC-SFS524(B) to 7024(B) HC-RFS103(B) to 503(B) HC-UFS72(B) to 502(B) HA-LH11K2 to 22K2 HA-LF30K24 to 55K24 HA-LF30K2 · 37K2 HA-LFS601 to 37K1 HA-LFS701M to 37K1M HA-LFS502 to 37K2 HA-LFS6014 to 37K14 HA-LFS701M4 to 50K1M4 HA-LFS11K24 to 55K24 HC-LFS52(B) to 302(B)	MS3102A20-29P	Straight	D/MS3106B20-29S	D/MS3057-12A
Angle		D/MS3108B20-29S		

3) For connection of brake

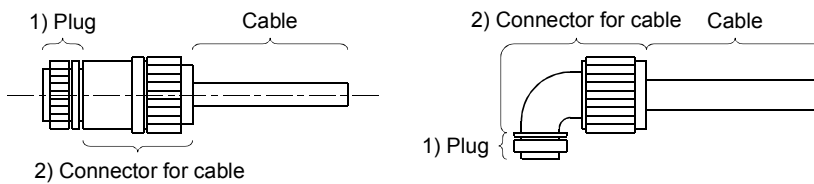

Servo Motor	Connector Supplied for Servo Motor	1) Plug (DDK)	Cable Side Connector						
			Type	Manufacturer	2) Connector for Cable				
					Cable OD	Model			
HC-SF121B to 301B HC-SF202B to 702B HC-SF203B · 353B HC-UF202B to 502B HC-SFS121B to 301B HC-SFS202B to 702B HC-SFS203B · 353B HC-SFS2024B to 7024B HC-UFS202B to 502B HC-LFS202B · 302B	MS3102A10SL-4P	D/MS3106A10SL-4S (D190)	Straight	Nippon flex	4 to 8	ACS-08RL-MS10F			
					8 to 12	ACS-12RL-MS10F			
				Daiwa Dengyo	5 to 8.3	YSO10-5 to 8			
						Angle	Nippon flex	4 to 8	ACA-08RL-MS10F
								8 to 12	ACA-12RL-MS10F
							Daiwa Dengyo	5 to 8.3	YLO10-5 to 8

3. CONNECTORS USED FOR SERVO MOTOR WIRING

(b) When using flexible conduits

1) For connection of power supply

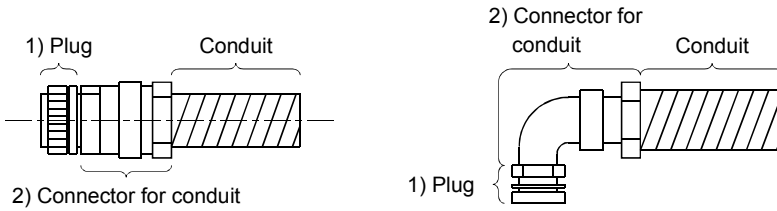

Servo Motor	Connector Supplied for Servo Motor	Cable Side Connector						
		1) Plug (DDK)	2) Connector for conduit				Conduit	
			Type	Manufacturer	Size	Model	Model	ID
HC-SF81(B) HC-SF52(B) to 152(B) HC-SF53(B) to 153(B) HC-RF103(B) to 203(B) HC-UF72(B) · 152(B) HC-SFS81(B) HC-SFS52(B) to 152(B) HC-SFS53(B) to 153(B) HC-SFS524(B) to 1524(B) HC-RFS103(B) to 203(B) HC-UFS72(B) · 152(B) HC-LFS52(B) to 152(B)	CE05-2A22-23PD-B	D/MS3106A22-23S(D190)	Straight	Nippon flex	1/2	RCC-104RL-MS22F	VF-04	14.0
					3/4	RCC-106RL-MS22F	VF-06	19.0
					1	RCC-108RL-MS22F	VF-08	24.4
				Daiwa Dengyo	16	MSA-16-22	FCV16	15.8
					22	MSA-22-22	FCV22	20.8
					28	MSA-28-22	FCV28	26.4
			Angle	Nippon flex	1/2	RCC-304RL-MS22F	VF-04	14.0
					3/4	RCC-306RL-MS22F	VF-06	19.0
				Daiwa Dengyo	1	RCC-308RL-MS22F	VF-08	24.4
					16	MAA-16-22	FCV16	15.8
HC-SF121(B) to 301(B) HC-SF202(B) to 502(B) HC-SF203(B) · 352(B) HC-RF353(B) to 503(B) HC-UF202(B) to 502(B) HC-SFS121(B) to 301(B) HC-SFS202(B) to 502(B) HC-SFS203(B) to 353(B) HC-SFS2024(B) to 5024(B) HC-RFS353(B) · 503(B) HC-UFS202(B) to 502(B) HA-LFS502 HC-LFS202(B) · 302(B)	CE05-2A24-10PD-B	D/MS3106A24-10S(D190)	Straight	Nippon flex	1/2	RCC-104RL-MS24F	VF-04	14.0
					3/4	RCC-106RL-MS24F	VF-06	19.0
					1	RCC-108RL-MS24F	VF-08	24.4
				Daiwa Dengyo	16	MSA-16-24	FCV16	15.8
					22	MSA-22-24	FCV22	20.8
					28	MSA-28-24	FCV28	26.4
			Angle	Nippon flex	1/2	RCC-304RL-MS24F	VF-04	14.0
					3/4	RCC-306RL-MS24F	VF-06	19.0
				Daiwa Dengyo	1	RCC-308RL-MS24F	VF-08	24.4
					16	MAA-16-24	FCV16	15.8
HC-SF702(B) HC-SFS702(B) HC-SFS7024(B) HA-LFS702	CE05-2A32-17PD-B	D/MS3106A32-17S(D190)	Straight	Nippon flex	3/4	RCC-106RL-MS32F	VF-06	19.0
					1	RCC-108RL-MS32F	VF-08	24.4
			Angle	Daiwa Dengyo	3/4	RCC-306RL-MS32F	VF-06	19.0
					1	RCC-308RL-MS32F	VF-08	24.4

3. CONNECTORS USED FOR SERVO MOTOR WIRING

2) For connection of encoder

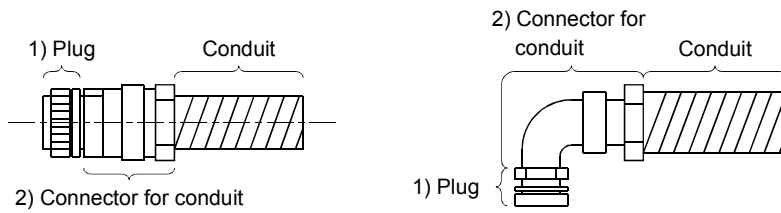

Servo Motor	Connector Supplied for Servo Motor	Cable Side Connector						
		1) Plug (DDK)	2) Connector for conduit				Conduit	
			Type	Manufacturer	Size	Model	Model	ID
HC-SF81(B) to 301(B) HC-SF52(B) to 702(B) HC-SF53(B) to 353(B) HC-RF103(B) to 503(B) HC-UF72(B) to 502(B) HC-SFS81(B) to 301(B) HC-SFS52(B) to 702(B) HC-SFS53(B) to 353(B) HC-SFS5024(B) to 7024(B) HC-RFS103(B) to 503(B) HC-UFS72(B) to 502(B) HA-LH11K2 to 22K2 HA-LF30K24 to 55K24 HA-LF30K2 · 37K2 HA-LFS601 to 37K1 HA-LFS701M to 37K1M HA-LFS502 to 37K2 HA-LFS6014 to 37K14 HA-LFS701M4 to 50K1M4 HA-LFS11K24 to 55K24 HC-LFS52(B) to 302(B)	MS3102A20-29P	D/MS3106A20-29S(D190)	Straight	Nippon flex	1/2	RCC-104RL-MS20F	VF-04	14.0
		3/4			RCC-106RL-MS20F	VF-06	19.0	
		Daiwa Dengyo		16	MSA-16-20	FCV16	15.8	
				22	MSA-22-20	FCV22	20.8	
			Angle	Nippon flex	1/2	RCC-304RL-MS20F	VF-04	14.0
		3/4			RCC-306RL-MS20F	VF-06	19.0	
		Daiwa Dengyo		16	MAA-16-20	FCV16	15.8	
				22	MAA-22-20	FCV22	20.8	

3) For connection of brake

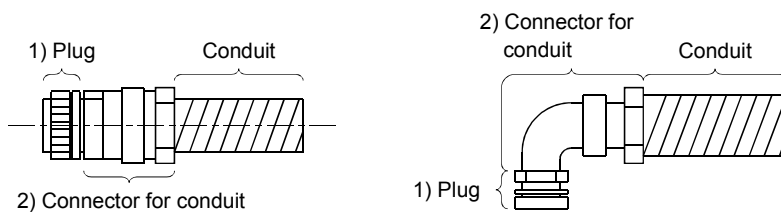

Servo Motor	Connector Supplied for Servo Motor	Cable Side Connector						
		1) Plug (DDK)	2) Connector for conduit				Conduit	
			Type	Manufacturer	Size	Model	Model	ID
HC-SF121B to 301B HC-SF202B to 702B HC-SF203B · 353B HC-UF202B to 502B HC-SFS121B to 301B HC-SFS202B to 702B HC-SFS203B · 353B HC-SFS2024B to 7024B HC-UFS202B to 502B HC-LFS202B · 302B	MS3102A10SL-4P	D/MS3106A10SL-4S(D190)	Straight	Nippon flex	1/4	RCC-102RL-MS10F	VF-02	8.3
		10			MSA-10-10	FCV10	10	
			Angle	Nippon flex	1/4	RCC-302RL-MS10F	VF-02	8.3
		Daiwa Dengyo			10	MAA-10-10	FCV10	10

3. CONNECTORS USED FOR SERVO MOTOR WIRING

(2) Waterproof (IP65), EN Standard, UL/C-UL Standard-compliant

(a) When using cabtyre cables

1) For connection of power supply

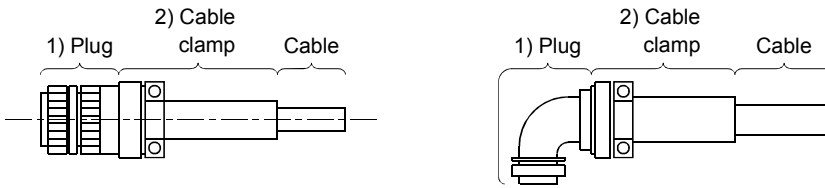

Servo Motor	Connector Supplied for Servo Motor	Cable Side Connector			
		1) Plug (DDK)		2) Cable clamp (DDK)	
		Type	Model	Cable OD	Model
HC-SF81(B) HC-SF52(B) to 152(B) HC-SF53(B) to 153(B) HC-RF103(B) to 203(B) HC-UF72(B) · 152(B) HC-SFS81(B) HC-SFS52(B) to 152(B) HC-SFS53(B) to 153(B) HC-SFS524(B) to 1524(B) HC-RFS103(B) to 203(B) HC-UFS72(B) · 152(B) HC-LFS52(B) to 152(B)	CE05-2A22-23PD-B	Straight Angle	CE05-6A22-23SD-D-BSS CE05-8A22-23SD-D-BAS	9.5 to 13 12.5 to 16	CE3057-12A-2-D CE3057-12A-1-D
HC-SF121(B) to 301(B) HC-SF202(B) to 502(B) HC-SF203(B) · 353(B) HC-RF353(B) to 503(B) HC-UF202(B) to 502(B) HC-SFS121(B) to 301(B) HC-SFS202(B) to 502(B) HC-SFS203(B) · 353(B) HC-SFS2024(B) to 5024(B) HC-RFS353(B) · 503(B) HC-UFS202(B) to 502(B) HA-LFS502 HC-LFS202(B) · 302(B)	CE05-2A24-10PD-B	Straight Angle	CE05-6A24-10SD-D-BSS CE05-8A24-10SD-D-BAS	13 to 15.5 15 to 19.1	CE3057-16A-2-D CE3057-16A-1-D
HC-SF702(B) HC-SFS702(B) HC-SFS7024(B) HA-LFS702	CE05-2A32-17PD-B	Straight Angle	CE05-6A32-17SD-D-BSS CE05-8A32-17SD-D-BAS	22 to 23.8	CE3057-20A-1-D

3. CONNECTORS USED FOR SERVO MOTOR WIRING

2) For connection of encoder

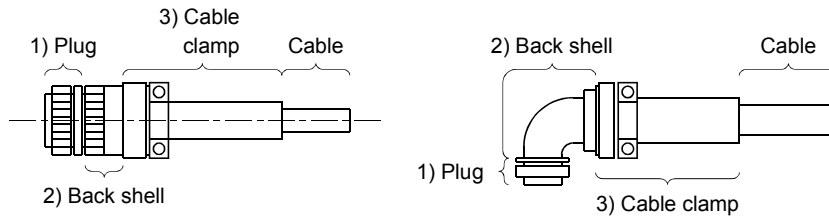

Servo Motor	Connector Supplied for Servo Motor	Cable Side Connector				
		1) Plug (DDK)	2) Back shell		3) Cable clamp (DDK)	
			Type	Model	Cable OD	Model
HC-SF81(B) to 301(B) HC-SF52(B) to 702(B) HC-SF53(B) to 353(B) HC-RF103(B) to 503(B) HC-UF72(B) to 502(B) HC-SFS81(B) to 301(B) HC-SFS52(B) to 702(B) HC-SFS53(B) to 353(B) HC-SFS524(B) to 7024(B) HC-RFS103(B) to 502(B) HC-UFS72(B) to 502(B) HA-LH11K2 to 22K2 HA-LF30K24 to 55K24 HA-LF30K2 · 37K2 HA-LFS601 to 37K1 HA-LFS701M to 37K1M HA-LFS502 to 37K2 HA-LFS6014 to 37K14 HA-LFS701M4 to 50K1M4 HA-LFS11K24 to 55K24 HC-LFS52(B) to 302(B)	MS3102A20-29P	D/MS3106A20-29S(D190)	Straight	CE02-20BS-S-D	6.8 to 10	CE3057-12A-3-D
Angle	CE-20BA-S-D					

3) For connection of brake

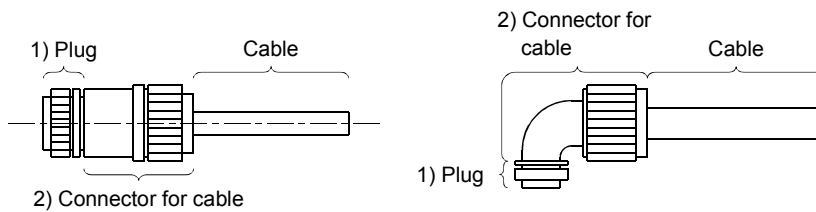

Servo Motor	Connector Supplied for Servo Motor	Cable Side Connector				
		1) Plug (DDK)	2) Connector for Cable			
			Type	Manufacturer	Cable OD	Model
HC-SF121B to 301B HC-SF202B to 702B HC-SF203B · 353B HC-UF202B to 502B HC-SFS121B to 301B HC-SFS202B to 702B HC-SFS203B · 353B HC-SFS2024B to 7024B HC-UFS202B to 502B HC-LFS202B · 302B HA-LFS601B to 801B HA-LFS701MB to 15K1MB HA-LFS11K2B to 22K2B HA-LFS6014B to 8014B HA-LFS701M4B to 15K1M4B HA-LFS11K24B to 22K24B	MS3102A10SL-4P	D/MS3106A10SL-4S(D190)	Straight	Nippon flex	4 to 8	ACS-08RL-MS10F
					8 to 12	ACS-12RL-MS10F
				Daiwa Dengyo	5 to 8.3	YSO-10-5 to 8
			Angle	Nippon flex	4 to 8	ACA-08RL-MS10F
					8 to 12	ACA-12RL-MS10F
				Daiwa Dengyo	5 to 8.3	YLO-10-5 to 8

3. CONNECTORS USED FOR SERVO MOTOR WIRING

(b) When using flexible conduits

1) For connection of power supply

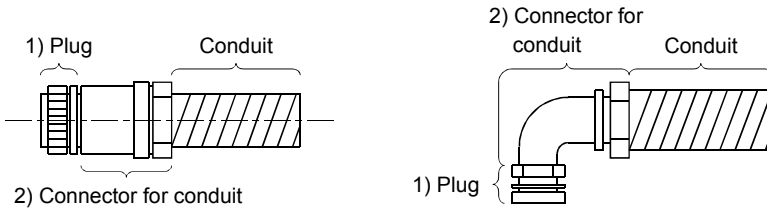

Servo Motor	Connector Supplied for Servo Motor	Cable Side Connector						
		1) Plug (DDK)	2) Connector for conduit				Conduit	
			Type	Manufacturer	Size	Model	Model	ID
HC-SF81(B) HC-SF52(B) to 152(B) HC-SF53(B) to 153(B) HC-RF103(B) to 203(B) HC-UF72(B) • 152(B) HC-SFS81(B) HC-SFS52(B) to 152(B) HC-SFS53(B) to 153(B) HC-SFS524(B) to 1524(B) HC-RFS103(B) to 203(B) HC-UFS72(B) • 152(B) HC-LFS52(B) to 152(B)	CE05-2A22-23PD-B	CE05-6A22-23SD-D	Straight	Nippon flex	1/2	RCC-104RL-MS22F	VF-04	14.0
					3/4	RCC-106RL-MS22F	VF-06	19.0
					1	RCC-108RL-MS22F	VF-08	24.4
				Daiwa Dengyo	16	MSA-16-22	FCV16	15.8
					22	MSA-22-22	FCV22	20.8
					28	MSA-28-22	FCV28	26.4
			Angle	Nippon flex	1/2	RCC-304RL-MS22F	VF-04	14.0
					3/4	RCC-306RL-MS22F	VF-06	19.0
					1	RCC-308RL-MS22F	VF-08	24.4
				Daiwa Dengyo	16	MAA-16-22	FCV16	15.8
					22	MAA-22-22	FCV22	20.8
					28	MAA-28-22	FCV28	26.4
HC-SF121(B) to 301(B) HC-SF202(B) to 502(B) HC-SF203(B) • 353(B) HC-RF353(B) to 503(B) HC-UF202(B) to 502(B) HC-SFS121(B) to 301(B) HC-SFS202(B) to 502(B) HC-SFS203(B) • 353(B) HC-SFS2024(B) to 5024(B) HC-RFS353(B) • 503(B) HC-UFS202(B) to 502(B) HA-LFS502 HC-LFS202(B) • 302(B)	CE05-2A24-10PD-B	CE05-6A24-10SD-D	Straight	Nippon flex	1/2	RCC-104RL-MS24F	VF-04	14.0
					3/4	RCC-106RL-MS24F	VF-06	19.0
					1	RCC-108RL-MS24F	VF-08	24.4
				Daiwa Dengyo	16	MSA-16-24	FCV16	15.8
					22	MSA-22-24	FCV22	20.8
					28	MSA-28-24	FCV28	26.4
			Angle	Nippon flex	1/2	RCC-304RL-MS24F	VF-04	14.0
					3/4	RCC-306RL-MS24F	VF-06	19.0
					1	RCC-308RL-MS24F	VF-08	24.4
				Daiwa Dengyo	16	MAA-16-24	FCV16	15.8
					22	MAA-22-24	FCV22	20.8
					28	MAA-28-24	FCV28	26.4
HC-SF702(B) HC-SFS702(B) HC-SFS7024(B) HA-LFS702	CE05-2A32-17PD-B	CE05-6A32-17SD-D	Straight	Nippon flex	3/4	RCC-106RL-MS32F	VF-06	19.0
					1	RCC-108RL-MS32F	VF-08	24.4
			Angle	Nippon flex	3/4	RCC-306RL-MS32F	VF-06	19.0
					1	RCC-308RL-MS32F	VF-08	24.4

3. CONNECTORS USED FOR SERVO MOTOR WIRING

2) For connection of encoder

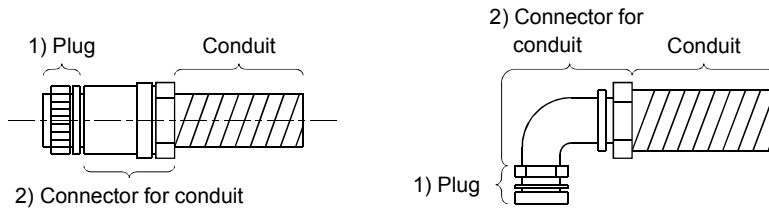

Servo Motor	Connector Supplied for Servo Motor	Cable Side Connector							
		1) Plug (DDK)	2) Connector for conduit				Conduit		
			Type	Manufacturer	Size	Model	Model	ID	
HC-SF81(B) to 301(B) HC-SF52(B) to 702(B) HC-SF53(B) to 353(B) HC-RF103(B) to 503(B) HC-UF72(B) to 502(B) HC-SFS81(B) to 301(B) HC-SFS52(B) to 702(B) HC-SFS53(B) to 353(B) HC-SFS524(B) to 7024(B) HC-RFS103(B) to 503(B) HC-UFS72(B) to 502(B) HA-LH11K2 to 22K2 HA-LF30K24 to 55K24 HA-LF30K2 * 37K2 HA-LFS601 to 37K1 HA-LFS701M to 37K1M HA-LFS502 to 37K2 HA-LFS6014 to 37K14 HA-LFS701M4 to 50K1M4 HA-LFS11K24 to 55K24 HC-LFS52(B) to 302 (B)	MS3102A20-29P	D/MS3106A20-29S(D190)	Straight	Nippon flex	1/2	RCC-104RL-MS20F	VF-04	14.0	
					3/4	RCC-106RL-MS20F	VF-06	19.0	
				Daiwa Dengyo	16	MSA-16-20	FCV16	15.8	
					22	MSA-22-20	FCV22	20.8	
				Angle	Nippon flex	1/2	RCC-304RL-MS20F	VF-04	14.0
						3/4	RCC-306RL-MS20F	VF-06	19.0
			Daiwa Dengyo		16	MAA-16-20	FCV16	15.8	
					22	MAA-22-20	FCV22	20.8	

3) For connection of brake

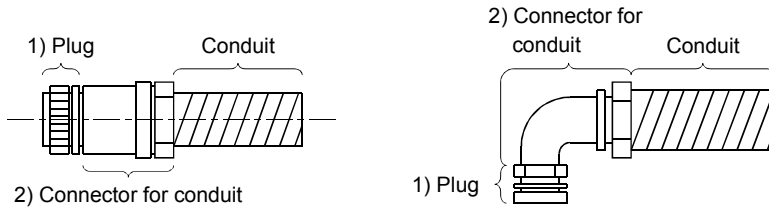

Servo Motor	Connector Supplied for Servo Motor	Cable Side Connector						
		1) Plug (DDK)	2) Connector for conduit				Conduit	
			Type	Manufacturer	Size	Model	Model	ID
HC-SF121B to 301B HC-SF202B to 702B HC-SF203B * 353B HC-UF202B to 502B HC-SFS121B to 301B HC-SFS202B to 702B HC-SFS203B * 353B HC-SFS2024B to 7024B HC-UFS202B to 502B HC-LFS202B * 302B HA-LFS601B to 801B HA-LFS701MB to 15K1MB HA-LFS11K2B to 22K2B HA-LFS6014B to 8014B HA-LFS701M4B to 15K1M4B HA-LFS11K24B to 22K24B	MS3102A10SL-4P	D/MS3106A10SL-4S(D190)	Straight	Nippon flex	1/4	RCC-102RL-MS10F	VF-02	8.3
					10	MSA-10-10	FCV10	10
				Daiwa Dengyo	1/4	RCC-302RL-MS10F	VF-02	8.3
					10	MAA-10-10	FCV10	10

3. CONNECTORS USED FOR SERVO MOTOR WIRING

3.1.4 HC-AQ series

Servo Motor	Servo Motor Side Connector (Molex)	Cable Side Connector (Molex)	
		Plug	Terminal
HC-AQ□(B)	(Note) 5557-12R-210	5559-12P-210	5558

Note. Terminal: 5556

3.1.5 HC-KFS • HC-MFS • HC-UFS3000r/min series

Use the connectors indicated in this section or equivalent for connection of the power supply, electromagnetic brake and encoder. These connectors may be used for the EN Standard and UL/C-UL Standard but are not waterproof.

(1) For connection of power supply and brake

Servo Motor	Connector Supplied for Servo Motor (Molex)	Cable Side Connector		Manual crimping tool
		Plug (Molex)	Terminal (Molex)	
HC-KFS□ HC-MFS□ HC-UFS13 to 73	5557-04R-210	5559-04P-210	5558PBT3L	57022-5300

Servo Motor	Connector Supplied for Servo Motor (Molex)	Cable Side Connector		Manual crimping tool
		Plug (Molex)	Terminal (Molex)	
HC-KFS□B HC-MFS□ B HC-UFS13 to 73B	5557-06R-210	5559-06P-210	5558PBT3L	57022-5300

(2) For connection of encoder

Servo Motor	Connector Supplied for Servo Motor (Tyco Electronics)	Cable Side Connector		
		Housing (Tyco Electronics)	Connector pin (Tyco Electronics)	Cable clamp (Toa Electric Industry)
HC-KFS□(B) HC-MFS□ (B) HC-UFS13 to 73(B)	1-172169-9	1-172161-9	170359-1 170363-1 (loose piece)	MTI-0002

3. CONNECTORS USED FOR SERVO MOTOR WIRING

3.1.6 HC-UF3000r/min series (Compliance with IP65)

Use the connectors indicated in this section or equivalent for connection of the power supply, electromagnetic brake and encoder. These connectors are waterproof.

(1) For connection of power

Servo Motor	Connector Supplied for Servo Motor (Hirose Electric)	Cable Side Connector	
		Plug (Hirose Electric)	Cable clamp (Hirose Electric)
HC-UF□(B)-S1 HC-UFS□(B)-S1	RM15WTP-4P	RM15WTJA-4S	(Note) RM15WTP-CP(8)

Note. The numeral within the parentheses indicates the applicable cable diameter. It depends on the used cable diameter.

(2) For connection of encoder

Servo Motor	Connector Supplied for Servo Motor (Hirose Electric)	Cable Side Connector	
		Plug (With cable clamp) (Hirose Electric)	Cable clamp (Hirose Electric)
HC-UF□(B)-S1 HC-UFS□(B)-S1	RM15WTP-10P	(Note) RM15WTJA-10S-(7)	

Note. The numeral within the parentheses indicates the applicable cable diameter. It depends on the used cable diameter.

(3) For connection of brake

Servo Motor	Connector Supplied for Servo Motor (Hirose Electric)	Cable Side Connector	
		Plug (Hirose Electric)	Cable clamp (Hirose Electric)
HC-UF□B-S1 HC-UFS□B-S1	RM15WTP-4P	RM15WTJA-4S	(Note) RM15WTP-CP(6)

Note. The numeral within the parentheses indicates the applicable cable diameter. It depends on the used cable diameter.

3. CONNECTORS USED FOR SERVO MOTOR WIRING





3.2 IP65, EN Standard-compliant options

The following options are available to satisfy the IP65 ingress protection and EN Standard.

To comply with the EN Standard, the power supply connector used must be any of these options or equivalent.

Product	Model	Description		Servo Motor
IP65-compliant encoder cable (For MR-J2 series • MR-J2-Super Series)	MR-ENCBL□M-H	Servo amplifier side connector (3M or equivalent) Connector: 10120-3000PE Shell kit: 10320-52F0-008	Encoder side connector (DDK) Plug: D/MS3106A20-29S(D190) Cable clamp: CE3057-12A-3-D Back shell: CE02-20BS-S-D	HC-SF series HC-RF series HC-UF2000r/min series HA-LF-UE series HA-FF-UE series HC-SFS series HC-RFS series HC-UFS2000r/min series HA-LFS series HC-LFS series
Encoder cable (For MR-H-□N series)	MR-EN1CBL□M-H	Servo amplifier side connector (Honda Tsushin Kogyo) Connector: PCR-S20FS Case: PCR-LS20LA1	Encoder side connector (DDK) Plug: D/MS3106A20-29S(D190) Cable clamp: CE3057-12A-3-D Back shell: CE02-20BS-S-D	HC-SF series HC-RF series HC-UF2000r/min series HA-LF-UE series
Encoder connector set (For MR-J2 series • MR-J2-Super Series)	MR-ENCNS	Servo amplifier side connector (3M or equivalent) Connector: 10120-3000PE Shell kit: 10320-52F0-008	Encoder side connector (DDK) Plug: D/MS3106A20-29S(D190) Cable clamp: CE3057-12A-3-D Back shell: CE02-20BS-S-D	HC-SF series HC-RF series HC-UF2000r/min series HC-SFS series HC-RFS series HC-UFS2000r/min series HA-LFS series HC-LFS series
Encoder connector set (For MR-H-□N series)	MR-EN1CNS	Servo amplifier side connector (Honda Tsushin Kogyo) Connector: PCR-S20FS Case: PCR-LS20LA1	Encoder side connector (DDK) Plug: D/MS3106A20-29S(D190) Cable clamp: CE3057-12A-3-D Back shell: CE02-20BS-S-D	HC-SF series HC-RF series HC-UF2000r/min series HA-LF series
EN Standard-compliant power connector set	MR-PWCNF	 Plug: CE05-6A14S-2SD-D (DDK) Cable connector: YSO14-9 to 11 (Daiwa Dengyo)		HA-FF□C-UE series

3. CONNECTORS USED FOR SERVO MOTOR WIRING

Product	Model	Description	Servo Motor
IP65/EN Standard-compliant power connector set	MR-PWCNS1	 Plug: CE05-6A22-23SD-D-BSS Cable clamp: CE3057-12A-2-D (DDK)	HC-SF81(B) HC-SF52(B) to 152(B) HC-SF53(B) to 153(B) HC-RF103(B) to 203(B) HC-UF72(B) · 152(B) HC-SFS81(B) HC-SFS52(B) to 152(B) HC-SFS53(B) to 153(B) HC-SFS524(B) to 1524(B) HC-RFS103(B) to 203(B) HC-UFS72(B) · 152(B) HC-LFS52(B) to 152(B)
IP65/EN Standard-compliant power connector set	MR-PWCNS2	 Plug: CE05-6A24-10SD-D-BSS Cable clamp: CE3057-16A-2-D (DDK)	HC-SF121(B) to 301(B) HC-SF202(B) to 502(B) HC-SF203(B) · 353(B) HC-RF353(B) · 503(B) HC-UF202(B) to 502(B) HC-SFS121(B) to 301(B) HC-SFS202(B) to 502(B) HC-SFS203(B) · 353(B) HC-SFS2024(B) to 5024(B) HC-RFS353(B) · 503(B) HC-UFS202(B) to 502(B) HA-LFS502 HC-LFS202(B) · 302(B)
Power connector set	MR-PWCNS3	 Plug: CE05-6A32-17SD-D-BSS Cable clamp: CE3057-20A-1-D (DDK)	HC-SF702(B) HC-SFS702(B) HC-SFS7024(B) HA-LFS702
IP65/EN Standard-compliant brake connector set	MR-BKCN (Note)	 Plug: D/MS3106A10SL-4S(D190) (DDK) Cable connector: YSO10-5 to 8 (Daiwa Dengyo)	HA-FF□CB-UE HC-SF121B to 301B HC-SF202B to 702B HC-SF203B · 353B HC-UF202B · 502B HC-SFS121B to 301B HC-SFS202B to 702B HC-SFS203B · 353B HC-SFS2024B to 7024B HC-RFS353B · 503B HC-UFS202B to 502B HC-LFS202B · 302B

Note. If it is used with the HA-FF□C-UE, the servo motor does not improve in ingress protection (IP54).

3. CONNECTORS USED FOR SERVO MOTOR WIRING

3.3 Signal arrangement of encoder connectors

The encoder connector of each servo motor has the following signal arrangement. The connectors shown are as seen from the pin side.

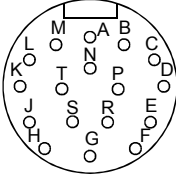
Servo Motor Series	Signal Arrangement																																						
HC-KF(-UE) series HC-MF(-UE) series HA-FF series HC-UF3000r/min series HC-KFS series HC-MFS series HC-UFS3000r/min series	Encoder connectors 1-172169-9 (AMP) <table border="1" style="margin-left: auto; margin-right: auto;"> <tr> <td>1</td> <td>2</td> <td>3</td> </tr> <tr> <td>MR</td> <td>MRR</td> <td>BAT</td> </tr> <tr> <td>4</td> <td>5</td> <td>6</td> </tr> <tr> <td>MD</td> <td>MDR</td> <td></td> </tr> <tr> <td>7</td> <td>8</td> <td>9</td> </tr> <tr> <td>P5</td> <td>LG</td> <td>SHD</td> </tr> </table>	1	2	3	MR	MRR	BAT	4	5	6	MD	MDR		7	8	9	P5	LG	SHD																				
1	2	3																																					
MR	MRR	BAT																																					
4	5	6																																					
MD	MDR																																						
7	8	9																																					
P5	LG	SHD																																					
HA-FF□C-UE series HC-SF series HC-RF series HC-UF2000r/min series HA-LH series HA-LF series HC-SFS series HC-RFS series HC-UFS2000r/min series HA-LFS series HC-LFS series	Encoder connectors <div style="display: flex; justify-content: space-around; align-items: center;">  <table border="1" style="margin-left: 20px;"> <thead> <tr> <th>Pin</th> <th>Signal</th> </tr> </thead> <tbody> <tr><td>A</td><td>MD</td></tr> <tr><td>B</td><td>MDR</td></tr> <tr><td>C</td><td>MR</td></tr> <tr><td>D</td><td>MRR</td></tr> <tr><td>E</td><td></td></tr> <tr><td>F</td><td>BAT</td></tr> <tr><td>G</td><td>LG</td></tr> <tr><td>H</td><td></td></tr> <tr><td>J</td><td></td></tr> </tbody> </table> <table border="1" style="margin-left: 20px;"> <thead> <tr> <th>Pin</th> <th>Signal</th> </tr> </thead> <tbody> <tr><td>K</td><td></td></tr> <tr><td>L</td><td></td></tr> <tr><td>M</td><td></td></tr> <tr><td>N</td><td>SHD</td></tr> <tr><td>P</td><td></td></tr> <tr><td>R</td><td>LG</td></tr> <tr><td>S</td><td>P5</td></tr> <tr><td>T</td><td></td></tr> </tbody> </table> </div>	Pin	Signal	A	MD	B	MDR	C	MR	D	MRR	E		F	BAT	G	LG	H		J		Pin	Signal	K		L		M		N	SHD	P		R	LG	S	P5	T	
Pin	Signal																																						
A	MD																																						
B	MDR																																						
C	MR																																						
D	MRR																																						
E																																							
F	BAT																																						
G	LG																																						
H																																							
J																																							
Pin	Signal																																						
K																																							
L																																							
M																																							
N	SHD																																						
P																																							
R	LG																																						
S	P5																																						
T																																							
HC-AQ series	Motor connector <table border="1" style="margin-left: auto; margin-right: auto;"> <tr> <td>12</td> <td>6</td> </tr> <tr> <td>MRR</td> <td>MR</td> </tr> <tr> <td>11</td> <td>5</td> </tr> <tr> <td>LG</td> <td>P5</td> </tr> <tr> <td>10</td> <td>4</td> </tr> <tr> <td></td> <td>SHD</td> </tr> <tr> <td>9</td> <td>3</td> </tr> <tr> <td>B1</td> <td>B2</td> </tr> <tr> <td>8</td> <td>2</td> </tr> <tr> <td>W</td> <td>U</td> </tr> <tr> <td>7</td> <td>1</td> </tr> <tr> <td>V</td> <td>E</td> </tr> </table>	12	6	MRR	MR	11	5	LG	P5	10	4		SHD	9	3	B1	B2	8	2	W	U	7	1	V	E														
12	6																																						
MRR	MR																																						
11	5																																						
LG	P5																																						
10	4																																						
	SHD																																						
9	3																																						
B1	B2																																						
8	2																																						
W	U																																						
7	1																																						
V	E																																						

4. INSPECTION

4. INSPECTION



- Before starting maintenance and/or inspection, turn off the power and wait for 15 minutes or more until the charge lamp turns off. Then, confirm that the voltage between P and N is safe with a voltage tester and others. Otherwise, an electric shock may occur. In addition, always confirm from the front of the servo amplifier whether the charge lamp is off or not.
- Any person who is involved in inspection should be fully competent to do the work. Otherwise, you may get an electric shock. For repair and parts replacement, contact your sales representative.

POINT

- Do not disassemble and/or repair the equipment on customer side.

(1) Inspection

It is recommended to make the following checks periodically.

- (a) Check the servo motor bearings, brake section, etc. for unusual noise.
- (b) Check the cables and the like for scratches and cracks. Especially when the junction cable is movable, perform periodic inspection according to operating conditions.
- (c) Check the servo motor shaft and coupling for misalignment.
- (d) Check the power supply connector and encoder connector tightening screws for looseness.

(2) Life

The following parts must be changed periodically as listed below. If any part is found faulty, it must be changed immediately even when it has not yet reached the end of its life, which depends on the operating method and environmental conditions. For parts replacement, please contact your sales representative.

Part Name	Guideline of Life	Remarks
Bearings	20,000 to 30,000 hours	The Guideline of Life field gives the reference time. If any fault is found before this time is reached, the part must be changed.
Encoder	20,000 to 30,000 hours	
Oil seal	5,000 hours	
Cooling fan	20,000 hours	

(a) Bearings

When the servo motor is run at rated speed under rated load, change the bearings in 20,000 to 30,000 hours as a guideline. This differs on the operating conditions. The bearings must also be changed if unusual noise or vibration is found during inspection.

(b) Oil seal

Must be changed in 5,000 hours of operation at rated speed as a guideline. These parts must also be changed if oil leakage, etc. is found during inspection.

MEMO

5. SPECIFICATIONS

5. SPECIFICATIONS

5.1 Standard specifications

Servo Motor		HC-MF Series (ultra low inertia, small capacity)					HA-FF Series (low inertia, small capacity)						
		053	13	23	43	73	053	13	23	33	43	63	
Applicable servo amplifier	MR-H□AN/BN/ACN/TN	20	20	40	60	100	10	10	20	40	40	60	
	MR-J2-□A/B/C	10	10	20	40	70	10	10	20	40	40	60	
Continuous running duty (Note 1 · 11)	Rated output [kW]	0.05	0.1	0.2	0.4	0.75	0.05	0.1	0.2	0.3	0.4	0.6	
	Rated torque	[N · m]	0.16	0.32	0.64	1.3	2.4	0.16	0.32	0.64	0.95	1.3	1.9
		[oz · in]	22.7	45.3	90.7	184	340	22.7	45.3	90.7	135	184	269
Rated speed (Note 1)	[r/min]	3000					3000						
Maximum speed	[r/min]	4500					4000						
Instantaneous permissible speed	[r/min]	5175					4600						
Maximum torque	[N · m]	0.48	0.95	1.9	3.8	7.2	0.48	0.95	1.9	2.9	3.8	5.7	
	[oz · in]	68.0	135	269	538	1020	68.0	135	269	411	538	808	
Power rate at continuous rated torque	[kW/s]	13.47	34.13	46.02	116.55	94.43	4.0	10.2	11.7	18.1	17.2	30.1	
Inertia moment (Note 3)	J [$\times 10^{-4}$ kg · m ²]	0.019	0.03	0.088	0.143	0.6	0.063	0.095	0.35	0.50	0.98	1.2	
	WK ² [oz · in ²]	0.104	0.16	0.48	0.78	3.28	0.344	0.52	1.91	2.73	5.36	6.56	
Recommended ratio of load inertia moment to servo motor shaft inertia moment (Note 2)		30 times or less					10 times or less						
Regenerative brake duty [times/min] (Note 4 · 15)	MR-H series	Servo amplifier's built-in regenerative resistor	(Note 5)	(Note 5)	(Note 5)	4275	1726	(Note 5)	(Note 5)	(Note 5)	1500	750	600
		MR-RB013(10W)	(Note 5)	(Note 5)				2071	1363	370			
		MR-RB033(30W)	(Note 5)	(Note 5)				(Note 5)	4088	1109			
	MR-J2 series	Servo amplifier's built-in regenerative resistor	(Note 5)	(Note 5)	(Note 5)	1010	400	(Note 5)	(Note 5)	(Note 5)	320	150	120
		MR-RB032(30W)	(Note 5)	(Note 5)	(Note 5)	3000	600	(Note 5)	(Note 5)	(Note 5)	950	450	360
		MR-RB12(100W)			(Note 5)	(Note 5)	2400			(Note 5)	3200	1500	1200
Power supply capacity		Refer to "Power supply equipment capacity and generated loss of servo amplifiers" in Servo Amplifier Instruction Manual.											
Rated current	[A]	0.85	0.85	1.5	2.8	5.1	0.6	1.1	1.3	1.9	2.5	3.6	
Maximum current	[A]	2.6	2.6	5	9	18	1.8	3.3	3.9	5.7	7.5	10.8	
Speed/position detector		Encoder common to absolute position and incremental detection systems (Resolution per servo motor 1 rotation : 8192 pulse/rev)					Encoder common to absolute position and incremental detection systems (Resolution per servo motor 1 rotation: 8192 pulse/rev)						
Accessories							V ring						
Insulation class		Class B					Class B						
Structure		Totally-enclosed, self-cooled (protection type: IP44 (Note 6 · 12))					Totally-enclosed, self-cooled (protection type: IP44 (Note 8 · 9 · 12))						
Environmental conditions (Note 7)		Refer to section 2.1					Refer to section 2.1						
Mass (Note 3)	[kg]	0.4	0.53	0.99	1.45	3.0	1.3	1.5	2.3	2.6	4.2	4.8	
	[lb]	0.88	1.17	2.18	3.20	6.61	2.87	3.31	5.07	5.73	9.26	10.6	

5. SPECIFICATIONS

Servo Motor		HC-SF 1000r/min Series (middle inertia, middle capacity)				HC-SF 2000r/min Series (middle inertia, middle capacity)							
		81	121	201	301	52	102	152	202	352	502	702	
Applicable servo amplifier	MR-H□AN/BN/AC/N□N	100	200	200	350	60	100	200	200	350	500	700	
	MR-J2-□□A/B/C	100	200	200	350	60	100	200	200	350			
Continuous running duty (Note 1 - 11)	Rated output [kW]	0.85	1.2	2.0	3.0	0.5	1.0	1.5	2.0	3.5	5.0	7.0	
	Rated torque [N·m] [oz·in]	8.12 1151	11.5 1630	19.1 2707	28.6 4053	2.39 339	4.78 677	7.16 1015	9.55 1353	16.7 2367	23.9 3387	33.4 4733	
Rated speed (Note 1)		1000				2000							
Maximum speed [r/min]		1500	1200			3000			2500		2000		
Instantaneous permissible speed [r/min]		1725	1380			3450			2875		2300		
Maximum torque	[N·m]	24.4	34.4	57.3	85.9	7.16	14.4	21.6	28.5	50.1	71.6	100.0	
	[oz·in]	3458	4875	8120	12173	1015	2041	3061	4039	7100	10146	14171	
Power rate at continuous rated torque [kW/s]		32.9	30.9	44.5	81.3	8.7	16.7	25.6	21.5	34.1	56.5	69.7	
Inertia moment (Note 3)	J [$\times 10^{-4}$ kg·m ²]	20.0	42.5	82	101	6.6	13.7	20.0	42.5	82.0	101	160	
	WK ² [oz·in ²]	109	232	448	552	36.1	74.9	109	232	448	552	875	
Recommended ratio of load inertia moment to servo motor shaft inertia moment (Note 2)		15 times or less				15 times or less							
Regenerative brake duty [times/min] (Note 4)	MR-H series	Servo amplifier's built-in regenerative resistor	440	335	174	141	207	170	179	84	43	39	32
		MR-RB31(300W)											57
		MR-RB32(300W)	1649				1241	638					
		MR-RB30(300W)				326					100	90	
		MR-RB34(300W)		774	401				412	193			
		MR-RB50(500W)				543					167	150	
	MR-J2 series	MR-RB51(500W)											95
		MR-RB54(500W)		1290	669				687	322			
		Servo amplifier' built-in regenerative resistor	140	240	100	84	56	54	136	64	31		
		MR-RB032(30W)	220				165	80					
		MR-RB12(100W)	740				560	270					
		MR-RB32(300W)	2220					810					
			730	330	250			408	192	95			
			1216	550	430			680	320	158			
Power supply capacity		Refer to "Power supply equipment capacity and generated loss of servo amplifiers" in Servo Amplifier Instruction Manual.											
Rated current [A]		5.1	7.1	9.6	16	3.2	6	9	11	17	26	35	
Maximum current [A]		15.3	21.3	28.8	48	9.6	18	27	33	51	84	105	
Speed/position detector		Encoder common to absolute position and incremental detection systems (Resolution per servo motor 1 rotation: 16384 pulse/rev)				Encoder common to absolute position and incremental detection systems (Resolution per servo motor 1 rotation: 16384 pulse/rev)							
Accessories		Oil seal				Oil seal							
Insulation class		Class F				Class F							
Structure		Totally-enclosed, self-cooled (protection type: IP65)				Totally-enclosed, self-cooled (protection type: IP65)(Note 12))							
Environmental conditions (Note 7)		Refer to section 2.1				Refer to section 2.1							
Mass (Note 3)	[kg]	9.0	12	19	23	5.0	7.0	9.0	12.0	19.0	23	32	
	[lb]	19.8	26.5	41.9	50.7	11.0	15.4	19.8	26.5	41.9	50.7	70.5	

5. SPECIFICATIONS

Servo Motor		HC-SF 3000r/min Series (middle inertia, middle capacity)					HC-RF Series (ultra low inertia, middle capacity)					
		53	103	153	203 (Note 13)	353 (Note 13)	103	153	203	353	503	
Applicable servo amplifier	MR-H□AN/BN/ACN/TN	60	100	200	200	350	200	200	350	500	500	
	MR-J2-□A/B/C	60	100	200	200	350	200	200	350			
Continuous running duty (Note 1・11)	Rated output [kW]	0.5	1.0	1.5	2.0	3.5	1.0	1.5	2.0	3.5	5.0	
	Rated torque	[N・m]	1.59	3.18	4.78	6.37	11.1	3.18	4.78	6.37	11.1	15.9
		[oz・in]	225	451	677	903	1573	451	677	903	1573	2253
Rated speed (Note 1)	[r/min]	3000					3000					
Maximum speed	[r/min]	3000					4500					
Instantaneous permissible speed	[r/min]	3450					5175					
Maximum torque	[N・m]	4.77	9.55	14.3	19.1	33.4	7.95	11.9	15.9	27.9	39.7	
	[oz・in]	676	1353	2026	2707	4733	1127	1686	2253	3954	5626	
Power rate at continuous rated torque	[kW/s]	3.8	7.4	11.4	9.5	15.1	67.4	120	176	150	211	
Inertia moment (Note 3)	J [$\times 10^{-4}$ kg・m ²]	6.6	13.7	20.0	42.5	82.0	1.5	1.9	2.3	8.6	12.0	
	WK ² [oz・in ²]	36.1	74.9	109.3	232.4	448.3	8.2	10.4	12.6	47.0	65.6	
Recommended ratio of load inertia moment to servo motor shaft inertia moment (Note 2)		15 times or less					5 times or less					
Regenerative brake duty [times/min] (Note 4)	MR-H series	Servo amplifier's built-in regenerative resistor	92	71	79	37	19	1056	834	689	174	125
		MR-RB32(300W)	552	267								
		MR-RB30(300W)					45			1589	401	288
		MR-RB34(300W)			183	86		2437	1924			
		MR-RB50(500W)					74			2648	669	479
	MR-J2 series	Servo amplifier' built-in regenerative resistor	25	24	82	24	14	1090	860	710		
		MR-RB032(30W)	73	36								
		MR-RB12(100W)	250	120								
		MR-RB32(300W)		360								
		MR-RB30(300W)			250	70	42	3270	2580	2130		
MR-RB50(500W)			410	110	70	5450	4300	3550				
Power supply capacity		Refer to "Power supply equipment capacity and generated loss of servo amplifiers" in Servo Amplifier Instruction Manual.										
Rated current	[A]	3.2	5.3	8.6	10.4	16.4	6.1	8.8	14	23	28	
Maximum current	[A]	9.6	15.9	25.8	31.2	49.2	18.4	23.4	37	58	70	
Speed/position detector		Encoder common to absolute position and incremental detection systems (Resolution per servo motor 1 rotation: 16384 pulse/rev)					Encoder common to absolute position and incremental detection systems (Resolution per servo motor 1 rotation: 16384 pulse/rev)					
Accessories		Oil seal					Oil seal					
Insulation class		Class F					Class F					
Structure		Totally-enclosed, self-cooled (protection type: IP65)					Totally-enclosed, self-cooled (protection type: IP65(Note 12))					
Environmental conditions (Note 7)		Refer to section 2.1					Refer to section 2.1					
Mass (Note 3)	[kg]	5.0	7.0	9.0	12	19	3.9	5.0	6.2	12.0	17.0	
	[lb]	11.0	15.4	19.8	26.5	41.9	8.6	11.0	13.7	26.5	37.5	

5. SPECIFICATIONS

Servo Motor		HC-UF 2000r/min Series (flat type * middle capacity)					HC-UF 3000r/min Series (flat type * small capacity)				HA-LH Series (low inertia * large capacity)			
		72	152	202	352	502	13	23	43	73(Notes 13)	11K2	15K2	22K2	
Item	MR-H□AN/BN/VAC/NIN	100	200	350	500	500	10	40	60	100	11K	15K	22K	
	MR-J2□A/B/C	70	200	350			10	20	40	70				
Applicable servo amplifier	Rated output [kW]	0.75	1.5	2.0	3.5	5.0	0.1	0.2	0.4	0.75	11	15	22	
	Rated torque	[N·m]	3.58	7.16	9.55	16.7	23.9	0.32	0.64	1.3	2.4	52.5	71.6	105
		[oz·in]	507	1015	1353	2367	3387	45	91	184	340	7435	10139	14869
Rated speed (Note 1)	[r/min]	2000					3000				2000			
Maximum speed	[r/min]	3000					4500				2000			
Instantaneous permissible speed	[r/min]	3450					5175				2300			
Maximum torque	[N·m]	10.7	21.6	28.5	50.1	71.6	0.95	1.9	3.8	7.2	158	215	263	
	[oz·in]	1516	3061	4039	7100	10146	135	269	538	1020	22375	30447	37244	
Power rate at continuous rated torque	[kW/s]	12.3	23.2	23.9	36.5	49.6	15.5	19.2	47.7	9.76	235	177	278	
Inertia moment (Note 3)	J [$\times 10^{-4}$ kg·m ²]	10.4	22.1	38.2	76.5	115	0.066	0.241	0.365	5.90	118	290	395	
	WK ² [oz·in ²]	56.9	120.8	208.9	418.3	628.8	0.4	1.3	2.0	32.3	642.4	1585.6	2159.6	
Recommended ratio of load inertia moment to servo motor shaft inertia moment (Note 2)		15 times or less									10 times or less			
Regenerative brake duty [times/min] (Note 4·15)	MR-H Series	Servo amplifier's built-in regenerative resistor	211	161	93	44	31	(Note5)	2530	1669	165	85 (Note10)	70 (Note10)	55 (Note10)
		MR-RB013(10W)						2241						
		MR-RB033(30W)						(Note5)						
		MR-RB32(300W)	791						(Note5)	(Note5)	619			
		MR-RB30(300W)			215	102	72							
		MR-RB34(300W)		372										
		MR-RB50(500W)			358	169	119							
		MR-RB54(500W)		620										
		MR-RB65(800W)										130 (Note14)		
	MR-RB66(1300W)											100 (Note14)		
	MR-RB67(1300W)												80 (Note14)	
	MR-J2 Series	Servo amplifier's built-in regenerative resistor	53	124	68			(Note5)	(Note5)	410	41			
		MR-RB032(30W)	79					(Note5)	(Note5)	1230	62			
		MR-RB12(100W)	264						(Note5)	4100	206			
		MR-RB30(300W)		372	203									
MR-RB32(300W)		791								618				
MR-RB50(500W)			620	338										
Power supply capacity		Refer to "Power supply equipment capacity and generated loss of servo amplifiers" in Servo Amplifier Instruction Manual.												
Rated current	[A]	5.4	9.7	14	23	28	0.76	1.5	2.8	4.3	68	87	126	
Maximum current	[A]	16.2	29.1	42	69	84	2.5	4.95	9.24	12.9	204	261	315	
Speed/position detector		Encoder common to absolute position and incremental detection systems (Resolution per servo motor 1 rotation: 16384 pulse/rev)					Encoder common to absolute position and incremental detection systems (Resolution per servo motor 1 rotation: 8192 pulse/rev)				Incremental encoder (Resolution per servo motor 1 rotation: 16384 pulse/rev)			
Cooling fan	Power supply	Voltage, frequency										One-phase 200 to 220VAC 50Hz, One-phase 200 to 230VAC 60Hz		
		Power consumption [W]										42 (50Hz) 54 (60Hz)		
	Rated current [A]	0.21 (50Hz) 0.25 (60Hz)												
Accessories		Oil seal					Oil seal				Oil seal			
Insulation class		Class F					Class B				Class F			
Structure		Totally-enclosed, self-cooled (protection type: IP65)					Totally-enclosed, self-cooled (protection type: IP65(Notes 9))				Totally-enclosed, force-cooling (protection type: JP44)			
Environmental conditions (Note 7)		Refer to section 2.1												
Mass (Note 3)	[kg]	8.0	11.0	16.0	20.0	24.0	0.8	1.5	1.7	5.0	70	108	135	
	[lb]	17.6	24.3	35.3	44.1	52.9	1.8	3.3	3.7	11.0	154.3	238.1	297.6	

5. SPECIFICATIONS

Item		Servo Motor	HC-KF Series (low inertia - small capacity)			
			053	13	23	43
Applicable servo amplifier		MR-H□AN/ BN/ACN/TN	10	10	20	40
		MR-J2-□	10A-A16 10B-A16 10C-A16	10A-A15 10B-A15 10C-A15	20A-A15 20B-A15 20C-A15	40A-A15 40B-A15 40C-A15
Continuous running duty (Note 1 - 11)	Rated output	[kW]	0.05	0.1	0.2	0.4
	Rated torque	[N · m]	0.16	0.32	0.64	1.3
		[oz · in]	22.7	45.3	90.7	184
Rated speed (Note 1)		[r/min]	3000			
Maximum speed		[r/min]	4500			
Instantaneous permissible speed		[r/min]	5175			
Maximum torque		[N · m]	0.48	0.95	1.9	3.8
		[oz · in]	68.0	135	269	538
Power rate at continuous rated torque		[kW/s]	4.78	12.1	15.8	36.7
Inertia moment (Note 3)	J	[×10 ⁻⁴ kg · m ²]	0.053	0.084	0.260	0.460
	WK ²	[oz · in ²]	0.29	0.459	1.422	2.515
Recommended ratio of load inertia moment to servo motor shaft inertia moment (Note 2)			15 times or less		24 times or less	22 times or less
Regenerative brake duty [times/min] (Note 4 - 15)	MR-H series	Servo amplifier's built-in regenerative resistor	(Note 5)	(Note 5)	(Note 5)	900
		MR-RB013(10W)	3580	2210	350	
		MR-RB033(30W)	(Note 5)	(Note 5)	1050	
	MR-J2 series	Servo amplifier's built-in regenerative resistor	(Note 5)	(Note 5)	(Note 5)	220
		MR-RB032(30W)	(Note 5)	(Note 5)	(Note 5)	660
		MR-RB12(100W)			(Note 5)	2200
Power supply capacity			Refer to "Power supply equipment capacity and generated loss of servo amplifiers" in Servo Amplifier Instruction Manual.			
Rated current		[A]	0.83	0.71	1.1	2.3
Maximum current		[A]	2.5	2.2	3.4	6.9
Speed/position detector			Encoder common to absolute position and incremental detection systems (Resolution per servo motor 1 rotation: 8192 pulses/rev)			
Accessory						
Insulation class			Class B			
Structure			Totally-enclosed, self-cooled (protection type: IP44 (Note 6))			
Environmental conditions (Note 7)			Refer to section 2.1			
Mass		[kg]	0.40	0.53	0.99	1.45
		[lb]	0.882	1.168	2.18	3.20

5. SPECIFICATIONS

Item		Servo Motor			
		HC-AQ Series (24VDC-compatible • compact size • small capacity)			
		0135	0235	0335	
Applicable servo amplifier		MR-J2-03A5 MR-J2-03B5 MR-J2-03C5			
Continuous running duty (Note 1 • 11)	Rated output [kW]	0.01	0.02	0.03	
	Rated torque	[N • m]	0.0318	0.0637	0.0955
		[oz • in]	4.503	9.021	13.524
Rated speed (Note 1)		3000 [r/min]			
Maximum speed		5000 [r/min]		4500	
Instantaneous permissible speed		5750 [r/min]		5175	
Maximum torque	[N • m]	0.0955	0.191	0.287	
	[oz • in]	13.524	27.048	40.643	
Power rate at continuous rated torque		2.0 [kW/s]	5.6	9.7	
Inertia moment (Note 3)	J [$\times 10^{-4}$ kg • m ²]	0.0050	0.0072	0.0094	
	WK ² [oz • in ²]	0.027	0.039	0.051	
Recommended ratio of load inertia moment to servo motor shaft inertia moment (Note 2)		30 times or less			
Power supply capacity		Refer to "Power supply equipment capacity and generated loss of servo amplifiers" in Servo Amplifier Instruction Manual.			
Rated current		2.4 [A]	2.4	2.3	
Maximum current		7.7 [A]	7.7	7.4	
Speed/position detector		Incremental encoder (Resolution per servo motor 1 rotation: 8192 pulses/rev)			
Accessory					
Insulation class		Class B			
Structure		Totally-enclosed, self-cooled (protection type: IP55 (Note 6))			
Environmental conditions (Note 7)		Refer to section 2.1			
Mass (Note 3)	[kg]	0.19	0.22	0.25	
	[lb]	0.419	0.485	0.551	

5. SPECIFICATIONS

Item		Servo Motor		HA-LF Series (three-phase, 200VAC-compatible, low inertia · large capacity)	
		MR-H□AN/BN		30K2	37K2
Applicable servo amplifier		MR-H□AN/BN		30K	37K
Compatible converter unit		MR-HP30KA			
Continuous running duty (Note 1 · 11)	Rated output	[kW]	30	37	
	Rated torque	[N · m]	143	177	
		[oz · in]	20250.6	25065.4	
Rated speed (Note 1)		[r/min]	2000		
Maximum speed		[r/min]	2000		
Instantaneous permissible speed		[r/min]	2300		
Maximum torque		[N · m]	358	442	
		[oz · in ²]	50697.2	62592.6	
Power rate at continuous rated torque		[kW/s]	373	480	
Inertia moment	J	[× 10 ⁻⁴ kg · m ²]	550	650	
	WK ²	[oz · in ²]	3007.1	3553.8	
Recommended ratio of load inertia moment to servo motor shaft inertia moment		10 times or less			
Regenerative brake duty [times/min] (Note 4)	MR-RB139 (1300W)		58	49	
	MR-RB137 (3900W) (3 units are required.)		174	147	
Power supply capacity		Refer to “Power supply equipment capacity and generated loss of servo amplifiers” in Servo Amplifier Instruction Manual.			
Rated current		[A]	166	204	
Maximum current		[A]	415	510	
Speed/position detector		Encoder common to absolute position and incremental detection systems (Resolution per servo motor 1 rotation: 16384 pulse/rev)			
Cooling fan	Power supply	Voltage · frequency	Three-phase 200 to 220VAC 50Hz, Three-phase 200 to 230VAC 60Hz		
		Power consumption [W]	45(50Hz)/63(60Hz)		
	Rated current	[A]	0.32(50Hz)/0.35(60Hz)		
Thermal protector		Maximum rated	125VAC/DC, 3A or 250VAC/DC, 2A		
		Minimum rated	6VAC/DC, 0.15A		
Accessories		Oil seal			
Insulation class		Class F			
Structure		Totally-enclosed force-cooled (protection type: IP44)			
Environmental conditions (Note 7)		Refer to section 2.1			
Mass (Note 3)		[kg]	160	180	
		[lb]	352.7	396.8	

5. SPECIFICATIONS

Item		Servo Motor	HA-LF Series (three-phase, 400VAC-compatible, low Inertia, large capacity)			
			30K24	37K24	45K24	55K24
Applicable servo amplifier		MR-H□AN4/BN4	30K	37K	45K	55K
Compatible converter unit		MR-HP55KA4				
Continuous running duty (Note 1 - 11)	Rated output	[kW]	30	37	45	55
	Rated torque	[N · m]	143	177	215	263
		[oz · in]	20250.6	25065.4	30446.6	37244.0
Rated speed (Note 1)		[r/min]	2000			
Maximum speed		[r/min]	2000			
Instantaneous permissible speed		[r/min]	2300			
Maximum torque		[N · m]	358	442	537	657
		[oz · in]	50697.2	62592.6	76045.8	930392
Power rate at continuous rated torque		[kW/s]	373	480	427	526
Inertia moment (Note 3)	J	[$\times 10^{-4}$ kg · m ²]	550	650	1080	1310
	WK ²	[oz · in ²]	3007.095	3553.84	5904.84	7162.354
Recommended ratio of load inertia moment to servo motor shaft inertia moment (Note 2)		10 times or less				
Regenerative brake duty [times/min] (Note 4)	MR-RB136-4 (1300W)		58	49	30	24
	MR-RB138-4 (3900W) (3 units are required.)		174	147	89	73
Power supply capacity		Refer to "Power supply equipment capacity and generated loss of servo amplifiers" in Servo Amplifier Instruction Manual.				
Rated current		[A]	83	102	131	143
Maximum current		[A]	208	255	328	358
Speed/position detector		Encoder common to absolute position and incremental detection systems (Resolution per servo motor 1 rotation: 16384 pulses/rev)				
Cooling fan	Power supply	Voltage · frequency	Three-phase 380 to 460VAC 50/60Hz			
		Power consumption [W]	65(50Hz)/85(60Hz)		110(50Hz)/150(60Hz)	
	Rated current [A]	0.12(50Hz)/0.14(60Hz)		0.20(50Hz)/0.22(60Hz)		
Thermal protector		Maximum rated	125VAC/DC, 3A or 250VAC/DC, 2A			
		Minimum rated	6VAC/DC, 0.15A			
Accessories		Oil seal				
Insulation class		Class F				
Structure		Totally-enclosed, force-cooled (protection type: IP44)				
Environmental conditions (Note 7)		Refer to section 2.1				
Mass (Note 3)		[kg]	160	180	230	250
		[lb]	352.739	396.832	507.063	551.155

5. SPECIFICATIONS

Servo Motor		HC-MFS Series (ultra low inertia · small capacity)					HC-KFS Series (low inertia · small capacity)					
		053	13	23	43	73	053	13	23	43	73	
Applicable servo amplifier/drive unit	MR-J2S-□A/B/CP/CL	10	10	20	40	70	10	10	20	40	70	
	MR-J2M-□DU	10	10	20	40	70	10	10	20	40	70	
Continuous running duty (Note 1 · 11)	Rated output [kW]	0.05	0.1	0.2	0.4	0.75	0.05	0.1	0.2	0.4	0.75	
	Rated torque	[N · m]	0.16	0.32	0.64	1.3	2.4	0.16	0.32	0.64	1.3	2.4
		[oz · in]	22.7	45.3	90.7	184	340	22.7	45.3	90.7	184	340
Rated speed (Note 1)		[r/min]	3000					3000				
Maximum speed		[r/min]	4500					4500				
Instantaneous permissible speed		[r/min]	5175					5175				
Maximum torque		[N · m]	0.48	0.95	1.9	3.8	7.2	0.48	0.95	1.9	3.8	7.2
		[oz · in]	68.0	135	269	538	1020	68.0	135	269	538	1020
Power rate at continuous rated torque		[kW/s]	13.47	34.13	46.02	116.55	94.43	4.78	12.1	15.8	36.7	37.7
Inertia moment (Note 3)	J [$\times 10^{-4}$ kg · m ²]		0.019	0.03	0.088	0.143	0.6	0.053	0.084	0.260	0.460	1.51
	WK ² [oz · in ²]		0.104	0.16	0.48	0.78	3.28	0.29	0.459	1.422	2.515	8.26
Recommended ratio of load inertia moment to servo motor shaft inertia moment (Note 2)			30 times or less					15 times or less		24 times or less	22 times or less	15 times or less
Regenerative brake duty [times/min] (Note 4 · 15)	MR-J2S series	Servo amplifier's built-in regenerative resistor	(Note 5)	(Note 5)	(Note 5)	1010	400	(Note 5)	(Note 5)	(Note 5)	220	190
		MR-RB032(30W)	(Note 5)	(Note 5)	(Note 5)	3000	600	(Note 5)	(Note 5)	(Note 5)	660	280
		MR-RB12(100W)			(Note 5)	(Note 5)	2400			(Note 5)	2200	940
		MR-RB32(300W)					(Note 5)					2800
Power supply capacity			Refer to "Power supply equipment capacity and generated loss of servo amplifiers" in Servo Amplifier Instruction Manual.									
Rated current		[A]	0.85	0.85	1.5	2.8	5.1	0.83	0.71	1.1	2.3	5.8
Maximum current		[A]	2.6	2.6	5	9	18	2.5	2.2	3.4	6.9	18.6
Speed/position detector			Encoder common to absolute position and incremental detection systems (Resolution per servo motor 1 rotation : 131072 pulse/rev)					Encoder common to absolute position and incremental detection systems (Resolution per servo motor 1 rotation : 131072 pulse/rev)				
Accessories												
Insulation class			Class B					Class B				
Structure			Totally-enclosed, self-cooled (protection type: IP55 (Note 6,12))					Totally-enclosed, self-cooled (protection type: IP55 (Note 6,12))				
Environmental conditions (Note 7)			Refer to section 2.1					Refer to section 2.1				
Mass (Note 3)		[kg]	0.4	0.53	0.99	1.45	3.0	0.40	0.53	0.99	1.45	3.0
		[lb]	0.88	1.17	2.18	3.20	6.61	0.882	1.168	2.18	3.20	6.61

5. SPECIFICATIONS

Servo Motor Item		HC-SFS1000r/min Series (200V-compatible, middle inertia, middle capacity)				HC-SFS 2000r/min Series (200V-compatible, middle inertia, middle capacity)							
		81	121	201	301	52	102	152	202	352	502	702	
Applicable servo amplifier/drive unit	MR-J2S-□A/B/CP/CL	100	200	200	350	60	100	200	200	350	500	700	
Continuous running duty (Note 1 • 11)	Rated output [kW]	0.85	1.2	2.0	3.0	0.5	1.0	1.5	2.0	3.5	5.0	7.0	
	Rated torque	[N • m]	8.12	11.5	19.1	28.6	2.39	4.78	7.16	9.55	16.7	23.9	33.4
		[oz • in]	1151	1630	2707	4053	339	677	1015	1353	2367	3387	4733
Rated speed (Note 1)	[r/min]	1000				2000							
Maximum speed	[r/min]	1500	1200			3000			2500		2000		
Instantaneous permissible speed	[r/min]	1725	1380			3450			2875		2300		
Maximum torque	[N • m]	24.4	34.4	57.3	85.9	7.16	14.4	21.6	28.5	50.1	71.6	100.0	
	[oz • in]	3458	4875	8120	12173	1015	2041	3061	4039	7100	10146	14171	
Power rate at continuous rated torque [kW/s]		32.9	30.9	44.5	81.3	8.7	16.7	25.6	21.5	34.1	56.5	69.7	
Inertia moment (Note 3)	J [$\times 10^{-4}$ kg • m ²]	20.0	42.5	82	101	6.6	13.7	20.0	42.5	82.0	101	160	
	WK ² [oz • in ²]	109	232	448	552	36.1	74.9	109	232	448	552	875	
Recommended ratio of load inertia moment to servo motor shaft inertia moment (Note 2)		15 times or less				15 times or less							
Regenerative brake duty [times/min] (Note 4 • 15)	MR-J2S series	Servo amplifier's built-in regenerative resistor	140	240	100	84	56	54	136	64	31	39	32
		MR-RB032(30W)	220				165	80					
		MR-RB12(100W)	740				560	270					
		MR-RB32(300W)	2220					810					
		MR-RB30(300W)		730	330	250			408	192	95	90	
		MR-RB50(500W)		1216	550	430			680	320	158	150	
		MR-RB31(300W)											57
MR-RB51(500W)												95	
Power supply capacity		Refer to "Power supply equipment capacity and generated loss of servo amplifiers" in Servo Amplifier Instruction Manual.											
Rated current	[A]	5.1	7.1	9.6	16	3.2	6	9	11	17	26	35	
Maximum current	[A]	15.3	21.3	28.8	48	9.6	18	27	33	51	84	105	
Speed/position detector		Encoder common to absolute position and incremental detection systems (Resolution per servo motor 1 rotation: 131072 pulse/rev)				Encoder common to absolute position and incremental detection systems (Resolution per servo motor 1 rotation: 131072 pulse/rev)							
Accessories		Oil seal				Oil seal							
Insulation class		Class F				Class F							
Structure		Totally-enclosed, self-cooled (protection type: IP65)				Totally-enclosed, self-cooled (protection type: IP65(Note 12))							
Environmental conditions (Note 7)		Refer to section 2.1				Refer to section 2.1							
Mass (Note 3)	[kg]	9.0	12	19	23	5.0	7.0	9.0	12.0	19.0	23	32	
	[lb]	19.8	26.5	41.9	50.7	11.0	15.4	19.8	26.5	41.9	50.7	70.5	

5. SPECIFICATIONS

Servo Motor		HC-SFS 3000r/min Series (200V-compatible, middle inertia · middle capacity)					
		53	103	153	203	353	
Applicable servo amplifier	MR-J2S-□A/B/CP/CL	60	100	200	200	350	
Continuous running duty (Note 1 · 11)	Rated output [kW]	0.5	1.0	1.5	2.0	3.5	
	Rated torque	[N · m]	1.59	3.18	4.78	6.37	11.1
		[oz · in]	225	451	677	903	1573
Rated speed (Note 1)	[r/min]	3000					
Maximum speed	[r/min]	3000					
Instantaneous permissible speed	[r/min]	3450					
Maximum torque	[N · m]	4.77	9.55	14.3	19.1	33.4	
	[oz · in]	676	1353	2026	2707	4733	
Power rate at continuous rated torque	[kW/s]	3.8	7.4	11.4	9.5	15.1	
Inertia moment (Note 3)	J [$\times 10^{-4}$ kg · m ²]	6.6	13.7	20.0	42.5	82.0	
	WK ² [oz · in ²]	36.1	74.9	109.3	232.4	448.3	
Recommended ratio of load inertia moment to servo motor shaft inertia moment (Note 2)		15 times or less					
Regenerative brake duty [times/min] (Note 4 · 15)	MR-J2S series	Servo amplifier's built-in regenerative resistor	25	24	82	24	14
		MR-RB032(30W)	73	36			
		MR-RB12(100W)	250	120			
		MR-RB32(300W)		360			
		MR-RB30(300W)			250	70	42
		MR-RB50(500W)			410	110	70
Power supply capacity		Refer to "Power supply equipment capacity and generated loss of servo amplifiers" in Servo Amplifier Instruction Manual.					
Rated current	[A]	3.2	5.3	8.6	10.4	16.4	
Maximum current	[A]	9.6	15.9	25.8	31.2	49.2	
Speed/position detector		Encoder common to absolute position and incremental detection systems (Resolution per servo motor 1 rotation : 131072 pulse/rev)					
Accessories		Oil seal					
Insulation class		Class F					
Structure		Totally-enclosed, self-cooled (protection type: IP65)					
Environmental conditions (Note 7)		Refer to section 2.1					
Mass (Note 3)	[kg]	5.0	7.0	9.0	12	19	
	[lb]	11.0	15.4	19.8	26.5	41.9	

5. SPECIFICATIONS

Item		Servo Motor	HC-SFS Series(400VAC-compatible, middle inertia - middle capacity)						
			524	1024	1524	2024	3524	5024	7024
Applicable servo amplifier	MR-J2S-□A4		60	100	200		350	500	700
Continuous running duty (Note 1 - 11)	Rated output [kW]		0.5	1.0	1.5	2.0	3.5	5.0	7.0
	Rated torque	[N · m]	2.39	4.78	7.16	9.55	16.7	23.9	33.4
		[oz · in]	338.5	676.9	1013.9	1352.4	2364.9	3384.5	4729.9
Rated speed (Note 1)	[r/min]		2000						
Maximum speed	[r/min]		3000			2500		2000	
Instantaneous permissible speed	[r/min]		3450			2875		2300	
Maximum torque	[N · m]		7.16	14.4	21.6	28.5	50.1	71.6	100.0
	[oz · in]		1013.9	2039.2	3058.8	4036	7094.8	10139.4	14161.2
Power rate at continuous rated torque	[kW/s]		8.7	16.7	25.6	21.5	34.1	56.5	69.7
Inertia moment (Note 3)	J [$\times 10^{-4}$ kg · m ²]		6.6	13.7	20.0	42.5	82.0	101	160
	WK ² [oz · in ²]		36.1	74.9	109.3	232.4	448.3	552.2	874.8
Recommended ratio of load inertia moment to servo motor shaft inertia moment (Note2)			15 times or less						
Regenerative brake duty [times/min] (Note 4)	MR-J2S Series	Servo amplifier's built-in regenerative resistor	56	54	136	64	31	39	32
		MR-RB1L-4(100W)	560						
		MR-RB3M-4(300W)		810					
		MR-RB3H-4(300W)			408	192			
		MR-RB5H-4(500W)			680	320			
		MR-RB3G-4(300W)					95	90	
		MR-RB5G-4(500W)					158	150	
		MR-RB34-4(300W)							57
MR-RB54-4(500W)							95		
Power supply capacity			Refer to "Power supply equipment capacity and generated loss of servo amplifiers" in Servo Amplifier Instruction Manual.						
Rated current [A]			1.5	2.8	4.4	5.4	8.6	14	17
Maximum current [A]			4.5	8.4	13.2	16.2	25.8	42	51
Speed/position detector			Encoder common to absolute position and incremental detection systems (Resolution per servo motor 1 rotation: 131072 pulse/rev)						
Accessories			Oil seal						
Insulation class			Class F						
Structure			Totally-enclosed, self-cooled(Protection type: IP65 (Note 12))						
Environmental conditions (Note 7)			Refer to section 2.1						
Mass (Note 3)	[kg]		5.0	7.0	9.0	12.0	19.0	23	32
	[lb]		11	15.4	19.8	26.5	41.9	50.7	70.5

5. SPECIFICATIONS

Servo Motor		HC-RFS Series (ultra low inertia · middle capacity)					
		103	153	203	353	503	
Item							
Applicable servo amplifier	MR-J2S-□A/B/CP/CL	200	200	350	500	500	
Continuous running duty (Note 1 · 11)	Rated output [kW]	1.0	1.5	2.0	3.5	5.0	
	Rated torque	[N · m]	3.18	4.78	6.37	11.1	15.9
		[oz · in]	450	677	902	1572	2252
Rated speed (Note 1)	[r/min]	3000					
Maximum speed	[r/min]	4500					
Instantaneous permissible speed	[r/min]	5175					
Maximum torque	[N · m]	7.95	11.9	15.9	27.9	39.7	
	[oz · in]	1126	1686	2253	3954	5626	
Power rate at continuous rated torque	[kW/s]	67.4	120	176	150	211	
Inertia moment (Note 3)	J [$\times 10^{-4}$ kg · m ²]	1.5	1.9	2.3	8.6	12.0	
	WK ² [oz · in ²]	8.2	10.4	12.6	47.0	65.6	
Recommended ratio of load inertia moment to servo motor shaft inertia moment (Note 2)		5 times or less					
Regenerative brake duty [times/min] (Note 4)	MR-J2S series	Servo amplifier's built-in regenerative resistor	1090	860	710	174	125
		MR-RB30(300W)	3270	2580	2130	401	288
		MR-RB50(500W)	5450	4300	3550	669	479
Power supply capacity		Refer to "Power supply equipment capacity and generated loss of servo amplifiers" in Servo Amplifier Instruction Manual.					
Rated current	[A]	6.1	8.8	14	23	28	
Maximum current	[A]	18.4	23.4	37	58	70	
Speed/position detector		Encoder common to absolute position and incremental detection systems (Resolution per servo motor 1 rotation: 131072 pulse/rev)					
Accessories		Oil seal					
Insulation class		Class F					
Structure		Totally-enclosed, self-cooled (protection type: IP65 (Note 12))					
Environmental conditions (Note 7)		Refer to section 2.1					
Mass (Note 3)	[kg]	3.9	5.0	6.2	12.0	17.0	
	[lb]	8.6	11.0	13.7	26.5	37.5	

5. SPECIFICATIONS

Servo Motor		HC-UFS 2000r/min Series (flat type · middle capacity)					HC-UFS 3000r/min Series (flat type · small capacity)				
		72	152	202	352	502	13	23	43	73	
Applicable servo amplifier/drive unit	MR-J2S □A/B/CP/CL	70	200	350	500	500	10	20	40	70	
	MR-J2M □DU						10	20	40	70	
Continuous running duty (Note 1 · 11)	Rated output [kW]	0.75	1.5	2.0	3.5	5.0	0.1	0.2	0.4	0.75	
	Rated torque	[N · m]	3.58	7.16	9.55	16.7	23.9	0.32	0.64	1.3	2.4
		[oz · in]	507	1015	1353	2367	3387	45	91	184	340
Rated speed (Note 1)	[r/min]	2000					3000				
Maximum speed	[r/min]	3000			2500		4500				
Instantaneous permissible speed	[r/min]	3450			2875		5175				
Maximum torque	[N · m]	10.7	21.6	28.5	50.1	71.6	0.95	1.9	3.8	7.2	
	[oz · in]	1516	3061	4039	7100	10146	135	269	538	1020	
Power rate at continuous rated torque	[kW/s]	12.3	23.2	23.9	36.5	49.6	15.5	19.2	47.7	9.76	
Inertia moment (Note 3)	J [$\times 10^{-4}$ kg · m ²]	10.4	22.1	38.2	76.5	115	0.066	0.241	0.365	5.90	
	WK ² [oz · in ²]	56.9	120.8	208.9	418.3	628.8	0.4	1.3	2.0	32.3	
Recommended ratio of load inertia moment to servo motor shaft inertia moment (Note 2)		15 times or less					15 times or less				
Regenerative brake duty [times/min] (Note 4 · 15)	MR-J2S Series	Servo amplifier's built-in regenerative resistor	53	124	68	44	31	(Note5)	(Note5)	410	41
		MR-RB032(30W)	79					(Note5)	(Note5)	1230	62
		MR-RB12(100W)	264					(Note5)	(Note5)	4100	206
		MR-RB30(300W)		372	203	102	72				
		MR-RB32(300W)	791								618
MR-RB50(500W)		620	338	169	119						
Power supply capacity		Refer to "Power supply equipment capacity and generated loss of servo amplifiers" in Servo Amplifier Instruction Manual.									
Rated current	[A]	5.4	9.7	14	23	28	0.76	1.5	2.8	4.3	
Maximum current	[A]	16.2	29.1	42	69	84	2.5	4.95	9.24	12.9	
Speed/position detector		Encoder common to absolute position and incremental detection systems (Resolution per servo motor 1 rotation : 131072 pulse/rev)					Encoder common to absolute position and incremental detection systems (Resolution per servo motor 1 rotation : 131072 pulse/rev)				
Accessories		Oil seal					Oil seal				
Insulation class		Class F					Class B				
Structure		Totally-enclosed, self-cooled (protection type: IP65)					Totally-enclosed, self-cooled (protection type: IP65(Note9))				
Environmental conditions (Note 7)		Refer to section 2.1					Refer to section 2.1				
Mass (Note 3)	[kg]	8.0	11.0	16.0	20.0	24.0	0.8	1.5	1.7	5.0	
	[lb]	17.6	24.3	35.3	44.1	52.9	1.8	3.3	3.7	11.0	

5. SPECIFICATIONS

Item		Servo Motor								
		HA-LFS 1000r/min Series (200VAC-compatible, low inertia · middle large capacity)								
		601 (Note 13)	801	12K1	15K1	20K1	25K1	30K1	37K1	
Applicable servo amplifier	MR-J2S-□A/B	700A-U058 700B-U058 700CP-U058 700CL-U058	11KA 11KB		15KA 15KB	22KA 22KB		30KA 30KB	37KA- U039 37KB- U039	
Compatible converter unit									MR-HP30KA	
Continuous running duty (Note 1 · 11)	Rated output [kW]	6	8	12	15	20	25	30	37 (75% ED)	
	Rated torque	[N · m] [oz · in]	57.3 8114	76.4 10819	115 16285	143 20251	191 27048	239 33845	286 40501	353 49989
Rated speed (Note 1)		[r/min] 1000								
Maximum speed		[r/min] 1200								
Instantaneous permissible speed		[r/min] 1380								
Maximum torque		[N · m]	172	229	344	415	477	597	716	883
		[oz · in]	24357	32429	48715	58769	67549	84542	101394	125044
Power rate at continuous rated torque		[kW/s]	313	265	445	373	561	528	626	668
Inertia moment (Note 3)	J [$\times 10^{-4}$ kg · m ²]	105	220	295	550	650	1080	1310	1870	
	WK ² [oz · in ²]	574.1	1202.8	1612.9	3007.1	3553.8	5904.8	7162.4	10224.1	
Recommended ratio of load inertia moment to servo motor shaft inertia moment (Note 2)		10 times or less								
Regenerative brake duty [times/min] (Note 4)	Servo amplifier's built-in regenerative resistor	158	354 (Note 10 · 14)	264 (Note 10 · 14)	230 (Note 10 · 14)	195 (Note 10 · 14)	117 (Note 10 · 14)			
	MR-RB31(300W)	278								
	MR-RB51(500W)	464								
	MR-RB65(800W)		354 (Note 14)	264 (Note 14)						
	MR-RB66(1300W)				230 (Note 14)					
	MR-RB67(1300W)					195 (Note 14)	117 (Note 14)			
	MR-RB139(1300W)							97	68	
MR-RB137(3900W)							290	203		
Power supply capacity		Refer to "Power supply equipment capacity and generated loss of servo amplifiers" in Servo Amplifier Instruction Manual.								
Rated current [A]		34	42	61	83	118	118	154	188	
Maximum current [A]		102	126	183	249	295	295	385	470	
Speed/position detector		Encoder common to absolute position and incremental detection systems (Resolution per servo motor 1 rotation: 131072 pulse/rev)								
Cooling fan	Power supply	Voltage · frequency	Three-phase 200 to 220 VAC 50Hz, One-phase 200 to 230 VAC 60Hz		Three-phase 200 to 230VAC 50Hz/60Hz					
		Power consumption [W]	42(50Hz)/ 54(60Hz)	62(50Hz)/ 76(60Hz)	65(50Hz)/ 85(60Hz)		120(50Hz)/ 175(60Hz)			
	Rated current [A]	0.21(50Hz)/ 0.25(60Hz)	0.18(50Hz)/ 0.17(60Hz)	0.20(50Hz)/ 0.22(60Hz)		0.65(50Hz)/ 0.80(60Hz)				
Thermal protector	Maximum rated		125VAC/DC, 3A or 250VAC/DC, 2A							
	Minimum rated		6VAC/DC, 0.15A							
Accessories		Oil seal								
Insulation class		Class F								
Structure		Totally-enclosed, force-cooled (protection type: IP44)								
Environmental conditions (Note 7)		Refer to section 2.1								
Mass (Note 3)	[kg]		55	95	115	160	180	230	250	335
	[lb]		121.3	209.4	253.5	352.7	396.8	507.1	551.6	738.5

5. SPECIFICATIONS

Item		Servo Motor						HA-LFS 1500r/min Series (200VAC-compatible, low inertia • middle large capacity)					
		701M (Note 13)		11K1M		15K1M		22K1M		30K1M		37K1M	
Applicable servo amplifier	MR-J2S-□	700A-U058 700B-U058 700CP-U059 700CL-U059		11KA 11KB		15KA 15KB		22KA 22KB		30KA 30KB		37KA-U042 37KB-U042	
Compatible converter unit								MR-HP30KA					
Continuous running duty (Note 1 • 11)	Rated output [kW]	7		11		15		22		30		37 (75% ED)	
	Rated torque	[N • m]	44.6		70.0		95.5		140		191		236
[oz • in]		6315.9		9912.9		13524		19825.7		27047.9		33420.5	
Rated speed (Note 1)		[r/min]		1500									
Maximum speed		[r/min]		2000									
Instantaneous permissible speed		[r/min]		2300									
Maximum torque	[N • m]	134		210		286		350		477		589	
	[oz • in]	18976		29738.6		40501.1		49564.3		67549.1		83409.6	
Power rate at continuous rated torque		[kW/s]		189		223		309		357		514	
Inertia moment (Note 3)	J [$\times 10^{-4}$ kg • m ²]	105		220		295		550		650		1080	
	WK ² [oz • in ²]	574.1		1202.8		1612.9		3007.1		3553.8		5904.8	
Recommended ratio if load inertia moment to servo motor shaft inertia moment (Note 2)								10 times or less					
Regenerative brake duty [times/min] (Note 4)	Servo amplifier's built-in regenerative resistor	70		158 (Note 10 • 14)		191 (Note 10 • 14)		102 (Note 10 • 14)					
	MR-RB31(300W)	124											
	MR-RB51(500W)	206											
	MR-RB65(800W)			158 (Note 14)									
	MR-RB66(1300W)					191 (Note 14)							
	MR-RB67(1300W)							102 (Note 14)					
	MR-RB139(1300W)									87		52	
MR-RB137(3900W)									260		156		
Power supply capacity		Refer to "Power supply equipment capacity and generated loss of servo amplifiers" in Servo Amplifier Instruction Manual.											
Rated current [A]		37		65		87		126		174		202	
Maximum current [A]		111		195		261		315		435		505	
Speed/position detector		Encoder common to absolute position and incremental detection systems (Resolution per servo motor 1 rotation: 131072 pulse/rev)											
cooling fan	Power supply	Voltage • frequency	One-phase 200 to 220 VAC 50Hz, One-phase 200 to 230 VAC 60Hz			Three-phase 200 to 230VAC 50Hz/60Hz							
		Power consumption [W]	42(50Hz)/ 54(60Hz)		62(50Hz)/ 76(60Hz)		65(50Hz)/ 85(60Hz)		120(50Hz)/ 175(60Hz)				
	Rated current [A]	0.21(50Hz)/ 0.25(60Hz)		0.18(50Hz)/ 0.17(60Hz)		0.20(50Hz)/ 0.22(60Hz)		0.65(50Hz)/ 0.80(60Hz)					
Thermal protector	Maximum rated	125VAC/DC, 3A or 250VAC/DC, 2A											
	Minimum rated	6VAC/DC, 0.15A											
Accessories		Oil seal											
Insulation class		Class F											
Structure		Totally-enclosed, force-cooled (protection type: IP44)											
Environmental conditions (Note 7)		Refer to section 2.1											
Mass (Note 3)	[kg]	55		95		115		160		180		230	
	[lb]	121.3		209.4		253.5		352.7		396.8		507.1	

5. SPECIFICATIONS

Item		Servo Motor						
		HA-LFS 2000r/min Series (200VAC-compatible, low inertia - middle large capacity)						
		502 (Note 13)	702 (Note 13)	11K2	15K2	22K2	30K2	37K2
Applicable servo amplifier	MR-J2S-□	500A 500B 500CP 500CL	700A 700B 700CP 700CL	11KA 11KB	15KA 15KB	22KA 22KB	30KA 30KB	37KA 37KB
Compatible converter unit		MR-HP30KA						
Continuous running duty (Note 1・11)	Rated output [kW]	5.0	7.0	11	15	22	30	37 (75% ED)
	Rated torque	[N・m] [oz・in]	23.9 3384.5	33.4 4729.9	52.5 7434.6	71.6 10139.4	105 14869.3	143 20250.6
Rated speed (Note 1)		[r/min] 2000						
Maximum speed		[r/min] 2000						
Instantaneous permissible speed		[r/min] 2300						
Maximum torque	[N・m]	71.6	100	158	215	263	358	442
	[oz・in]	10139.4	14161.2	22374.7	30446.6	37244	50697.2	62592.6
Power rate at continuous rated torque [kW/s]		77.2	118	263	233	374	373	480
Inertia moment (Note 3)	J [$\times 10^{-4}$ kg・m ²]	74.0	94.2	105	220	295	550	650
	WK ² [oz・in ²]	404.6	515	574.1	1202.8	1612.9	3007.1	3553.8
Recommended ratio of load inertia moment to servo motor shaft inertia moment (Note 2)		10 times or less						
Regenerative brake duty [times/min] (Note 4)	Servo amplifier's built-in regenerative resistor	50	50	186 (Note 10・14)	144 (Note 10・14)	107 (Note 10・14)		
	MR-RB30(300W)	120						
	MR-RB31(300W)		95					
	MR-RB50(500W)	200						
	MR-RB51(500W)		160					
	MR-RB65(800W)			186(Note 14)				
	MR-RB66(1300W)				144(Note 14)			
	MR-RB67(1300W)					107(Note 14)		
	MR-RB139(1300W)					58	49	
	MR-RB137(3900W)					174	147	
Power supply capacity		Refer to "Power supply equipment capacity and generated loss of servo amplifiers" in Servo Amplifier Instruction Manual.						
Rated current [A]		25	34	63	77	112	166	204
Maximum current [A]		75	102	189	231	280	415	510
Speed/position detector		Encoder common to absolute position and incremental detection systems (Resolution per servo motor 1 rotation: 131072 pulse/rev)						
Cooling fan	Power supply	Voltage・frequency			One-phase 200 to 220 VAC 50Hz, One-phase 200 to 230 VAC 60Hz	Three-phase 200 to 230VAC 50Hz/60Hz		
		Power consumption [W]			42(50Hz)/ 54(60Hz)	62(50Hz)/ 76(60Hz)	65(50Hz)/ 85(60Hz)	
	Rated current [A]			0.21(50Hz)/ 0.25(60Hz)	0.18(50Hz)/ 0.17(60Hz)	0.20(50Hz)/ 0.22(60Hz)		
Thermal protector	Maximum rated	125VAC/DC, 3A or 250VAC/DC, 2A						
	Minimum rated	6VAC/DC, 0.15A						
Accessories		Oil seal						
Insulation class		Class F						
Structure		Totally-enclosed, self-cooled (protection: IP65)			Totally-enclosed, force-cooled (protection: IP44)			
Environmental conditions (Note 7)		Refer to section 2.1						
Mass (Note 3)	[kg]	28	35	55	95	115	160	180
	[lb]	61.7	77.2	121.3	209.4	253.5	352.7	396.8

5. SPECIFICATIONS

Item		Servo Motor	HA-LFS 1000r/min Series (400VAC-compatible, low inertia · large capacity)							
			6014	8014	12K14	15K14	20K14	25K14	30K14	37K14
Applicable servo amplifier	MR-J2S-□	700A4-U071	11KA4	11KA4	15KA4	22KA4	30KA4	30KA4	37KA4	
		700B4-U071	11KB4	11KB4	15KB4	22KB4	30KB4	30KB4	37KB4	
Compatible converter unit							MR-HP55KA4			
Continuous running duty (Note 1 · 11)	Rated output [kW]		6	8	12	15	20	25	30	37
	Rated torque	[N · m]	57.3	76.4	115	143	191	239	286	353
		[oz · in]	8114.4	10819.1	16285.4	20250.56	27047.95	33845.34	40501.11	49989.14
Rated speed (Note 1)		[r/min]	1000							
Maximum speed		[r/min]	1200							
Instantaneous permissible speed		[r/min]	1380							
Maximum torque		[N · m]	172	229	344	415	477	597	716	883
		[oz · in]	24357.3	32429.21	48714.63	58769.1	67549.06	84542.54	101394.4	125043.65
Power rate at continuous rated torque		[kW/s]	313	265	445	373	561	528	626	668
Inertia moment (Note 3)	J	[$\times 10^{-4}$ kg · m ²]	105	220	295	550	650	1080	1310	1870
	WK ²	[oz · in ²]	574.1	1202.8	1612.9	3007.1	3553.8	5904.8	7162.4	10224.1
Recommended ratio of load inertia moment to servo motor shaft inertia moment (Note 2)			10 times or less							
Regenerative brake duty [times/min] (Note 4)	Servo amplifier's supplied regenerative resistor		158	354 (Note 10 · 14)	264 (Note 10 · 14)	230 (Note 10 · 14)	195 (Note 10 · 14)			
	MR-RB34-4(300W)		278							
	MR-RB54-4(500W)		464							
	MR-RB6B-4(800W)			354 (Note 14)	264 (Note 14)					
	MR-RB60-4(1300W)					230 (Note 14)				
	MR-RB6K-4(1300W)						195 (Note 14)			
	MR-RB136-4(1300W)							118	97	68
MR-RB138-4(3900W)							354	290	203	
Power supply capacity			Refer to "Power supply equipment capacity and generated loss of servo amplifiers" in Servo Amplifier Instruction Manual.							
Rated current [A]			17	20	30	40	55	70	77	95
Maximum current [A]			51	63	93	126	148	175	193	235
Speed/position detector			Encoder common to absolute position and incremental detection systems (Resolution per servo motor 1 rotation: 131072 pulse/rev)							
Cooling fan	Power supply	Voltage · frequency	One-phase 200 to 220VAC/50Hz, One-phase 200 to 230VAC/60Hz	Three-phase 380 to 440VAC 50Hz, Three-phase 380 to 480VAC 60Hz	Three-phase 380 to 460VAC 50Hz, Three-phase 380 to 480VAC 60Hz					
		Power consumption [W]	42 (50Hz)/54 (60Hz)	62 (50Hz)/76 (60Hz)	65 (50Hz)/85 (60Hz)		110 (50Hz)/150 (60Hz)			
	Rated current [A]	0.21 (50Hz)/0.25 (60Hz)	0.14 (50Hz)/0.11 (60Hz)	0.12 (50Hz)/0.14 (60Hz)		0.20 (50Hz)/0.22 (60Hz)				
Thermal protector	Maximum rated		125VAC/DC, 3A or 250VAC/DC, 2A							
	Minimum rated		6VAC/DC, 0.15A							
Accessories			Oil seal							
Insulation class			Class F							
Structure			Totally-enclosed, force-cooled (protection: IP44)							
Environmental conditions (Note 7)			Refer to section 2.1							
Mass (Note 3)		[kg]	55	95	115	160	180	230	250	335
		[lb]	121.3	209.4	209.43	352.7	396.8	507	551.2	738.5

5. SPECIFICATIONS

Item		Servo Motor	HA-LFS 1500r/min Series (400VAC-compatible, low inertia · large capacity)							
			701M4	11K1M4	15K1M4	22K1M4	30K1M4	37K1M4	45K1M4	50K1M4
Applicable servo amplifier	MR-J2S-□		700A4-U073	11KA4 11KB4	15KA4 15KB4	22KA4 22KB4	30KA4 30KB4	37KA4 37KB4	45KA4 45KB4	55KA4 55KB4
			700B4-U073							
Compatible converter unit			MR-HP55KA4							
Continuous running duty (Note 1 · 11)	Rated output	[kW]	7	11	15	22	30	37	45	50
	Rated torque	[N · m]	44.6	70.0	95.5	140	191	236	286	318
[oz · in]		6315.9	9912.86	13523.97	19825.72	27047.95	33420.5	40501.11	45032.71	
Rated speed (Note 1)		[r/min]	1500							
Maximum speed		[r/min]	2000							
Instantaneous permissible speed		[r/min]	2300							
Maximum torque		[N · m]	134	210	286	350	477	589	716	796
		[oz · in]	18976	29738.6	40501.1	49564.3	67549.1	83409.6	101394.3	112723.4
Power rate at continuous rated torque		[kW/s]	189	223	309	357	561	514	626	542
Inertia moment (Note 3)	J	[$\times 10^{-4}$ kg · m ²]	105	220	295	550	650	1080	1310	1870
	WK ²	[oz · in ²]	574.1	1202.8	1612.9	3007.1	3553.8	5904.8	7162.4	10224.1
Recommended ratio of load inertia moment to servo motor shaft inertia moment (Note 2)			10 times or less							
Regenerative brake duty [times/min] (Note 4)	Servo amplifier's supplied regenerative resistor		70	158 (Note 10 · 14)	191 (Note 10 · 14)	102 (Note 10 · 14)				
	MR-RB34-4(300W)		124							
	MR-RB54-4(500W)		206							
	MR-RB6B-4(800W)		124	158 (Note 14)						
	MR-RB60-4(1300W)		206		191 (Note 14)					
	MR-RB6K-4(1300W)					102 (Note 14)				
	MR-RB136-4(1300W)						87	52	43	30
MR-RB138-4(3900W)						260	156	129	90	
Power supply capacity			Refer to "Power supply equipment capacity and generated loss of servo amplifiers" in Servo Amplifier Instruction Manual.							
Rated current		[A]	18	31	41	63	87	101	128	143
Maximum current		[A]	54	99	132	158	218	253	320	358
Speed/position detector			Encoder common to absolute position and incremental detection systems (Resolution per servo motor 1 rotation: 131072 pulse/rev)							
Cooling fan	Power supply	Voltage · frequency	One-phase 200 to 220VAC/50Hz, One-phase 200 to 230VAC/60Hz	Three-phase 380 to 440VAC 50Hz, Three-phase 380 to 480VAC 60Hz	Three-phase 380 to 460VAC 50Hz, Three-phase 380 to 480VAC 60Hz					
		Power consumption [W]	42 (50Hz)/54 (60Hz)	62 (50Hz)/76 (60Hz)	65 (50Hz)/85 (60Hz)		110 (50Hz)/150 (60Hz)			
	Rated current [A]	0.21 (50Hz)/0.25 (60Hz)	0.14 (50Hz)/0.11 (60Hz)	0.12 (50Hz)/0.14 (60Hz)		0.20 (50Hz)/0.22 (60Hz)				
Thermal protector	Maximum rated		125VAC/DC, 3A or 250VAC/DC, 2A							
	Minimum rated		6VAC/DC, 0.15A							
Accessories			Oil seal							
Insulation class			Class F							
Structure			Totally-enclosed, force-cooled (protection: IP44)							
Environmental conditions (Note 7)			Refer to section 2.1							
Mass (Note 3)		[kg]	55	95	115	160	180	230	250	335
		[lb]	121.3	209.4	253.5	352.7	396.8	507.1	551.2	738.5

5. SPECIFICATIONS

Item		Servo Motor	HA-LFS 2000r/min Series (400VAC-compatible, low inertia • large capacity)						
			11K24	15K24	22K24	30K24	37K24	45K24	55K24
Applicable servo amplifier	MR-J2S-□A4/B4		11K	15K	22K	30K	37K	45K	55K
Compatible converter unit			MR-HP55KA4						
Continuous running duty (Note 1 • 11)	Rated output [kW]		11	15	22	30	37	45	55
	Rated torque [N • m]		52.5	71.6	105	143	177	215	263
	[oz • in]		7434.6	10139.4	14869.3	20250.6	25065.4	30446.6	37244
Rated speed (Note 1)			2000 [r/min]						
Maximum speed			2000 [r/min]						
Instantaneous permissible speed			2300 [r/min]						
Maximum torque	[N • m]		158	215	263	358	442	537	657
	[oz • in]		22374.7	30446.6	37244	50697.2	62592.6	76045.8	93039.3
Power rate at continuous rated torque [kW/s]			263	233	374	373	480	427	526
Inertia moment (Note 3)	J [$\times 10^{-4}$ kg • m ²]		105	220	295	550	650	1080	1310
	WK ² [oz • in ²]		574.1	1202.8	1612.9	3007.1	3553.8	5904.8	7162.4
Recommended ratio of load inertia moment to servo motor shaft inertia moment (Note 2)			10 times or less						
Regenerative brake duty [times/min] (Note 4)	Servo amplifier's supplied regenerative resistor		186 (Note 10 • 14)	144 (Note 10 • 14)	107 (Note 10 • 14)				
	MR-RB6B-4(800W)		186 (Note 14)						
	MR-RB60-4(1300W)			144 (Note 14)					
	MR-RB6K-4(1300W)				107 (Note 14)				
	MR-RB136-4(1300W)					58	49	30	24
	MR-RB138-4(3900W)					174	147	89	73
Power supply capacity			Refer to "Power supply equipment capacity and generated loss of servo amplifiers" in Servo Amplifier Instruction Manual.						
Rated current [A]			32	40	57	83	102	131	143
Maximum current [A]			96	120	171	208	255	328	358
Speed/position detector			Encoder common to absolute position and incremental detection systems (Resolution per servo motor 1 rotation: 131072 pulse/rev)						
Cooling fan	Power supply	Voltage • frequency	One-phase 200 to 220VAC/50Hz, One-phase 200 to 230VAC/60Hz	Three-phase 380 to 440VAC 50Hz, Three-phase 380 to 480VAC 60Hz	Three-phase 380 to 460VAC 50Hz, Three-phase 380 to 480VAC 60Hz				
		Power consumption [W]	42 (50Hz)/ 54 (60 Hz)	62 (50Hz)/ 76 (60Hz)	65 (50Hz)/ 85 (60Hz)		110 (50Hz)/ 150 (60Hz)		
	Rated current [A]	0.21 (50Hz)/ 0.25 (60 Hz)	0.14 (50Hz)/ 0.11 (60Hz)	0.12 (50Hz)/ 0.14 (60Hz)		0.20 (50Hz)/ 0.22 (60Hz)			
Thermal protector	Maximum rated		125VAC/DC, 3A or 250VAC/DC, 2A						
	Minimum rated		6VAC/DC, 0.15A						
Accessories			Absolute • Encoder, oil seal						
Insulation class			Class F						
Structure			Totally-enclosed, force-cooled (protection: IP44)						
Environmental conditions (Note 7)			Refer to section 2.1						
Mass (Note 3)	[kg]		55	95	115	160	180	230	250
	[lb]		121.3	209.4	253.5	352.7	396.8	507.1	551.2

5. SPECIFICATIONS

Item		Servo Motor	HC-LFS Series (low inertia • middle capacity)				
			52	102	152	202	302
Applicable servo amplifier	MR-J2S-□A/B/CP/CL		60	100	200	350	500
Continuous running duty (Note 1 • 11)	Rated output	[kW]	0.5	1.0	1.5	2.0	3.0
	Rated torque	[N • m]	2.39	4.78	7.16	9.55	14.3
		[oz • in]	338.5	676.9	1013.9	1352.4	2025.1
Rated speed (Note 1)		[r/min]	2000				
Maximum speed		[r/min]	3000				
Instantaneous permissible speed		[r/min]	3450				
Maximum torque		[N • m]	7.16	14.4	21.6	28.5	42.9
		[oz • in]	1013.9	2039.2	3058.8	4036	6075.2
Power rate at continuous rated torque		[kW/s]	17.9	49.7	80.1	41.5	56.8
Inertia moment (Note 3)	J	[$\times 10^{-4}$ kg • m ²]	3.2	4.6	6.4	22	36
	WK ²	[oz • in ²]	17.5	25.2	35	120.3	196.8
Recommended ratio of load inertia moment to servo motor shaft inertia moment (Note 2)			10 times or less				
Regenerative brake duty [times/min] (Note 4 • 15)	Servo amplifier' built-in regenerative resistor		115	160	425	120	70
	MR-RB032(30W)		340	235			
	MR-RB12(100W)		1150	800			
	MR-RB30(300W)				1270	370	215
	MR-RB32(300W)			2410			
MR-RB50(500W)				2120	615	355	
Power supply capacity			Refer to "Power supply equipment capacity and generated loss of servo amplifiers" in Servo Amplifier Instruction Manual.				
Rated current		[A]	3.2	5.9	9.9	14	23
Maximum current		[A]	9.6	18	30	42	69
Speed/position detector			Encoder common to absolute position and incremental detection systems (Resolution per servo motor 1 rotation: 131072 pulse/rev)				
Accessories			Oil seal				
Insulation class			Class F				
Structure			Totally-enclosed, self-cooled (protection type: IP65)				
Environmental conditions (Note 7)			Refer to section 2.1				
Mass (Note 3)		[kg]	6.5	8.0	10.0	21	28
		[lb]	14.33	17.6	22	46.3	61.7

5. SPECIFICATIONS

Note 1. When the power supply voltage drops, we cannot guarantee the output and rated speed.

2. If the load inertia moment ratio exceeds the indicated value, please consult us.
3. This ratio is the load inertia moment ratio to the inertia moment of the servo motor. If the load inertia moment ratio exceeds the indicated value, please consult us. When the servo motor is equipped with reduction gear or electromagnetic brake, refer to the corresponding outline dimension drawing. For the EN Standard- and UL/C-UL Standard-compliant models, please consult us.
4. The regenerative brake duty indicated is the permissible duty when the servo motor running without load at the rated speed is decelerated to a stop. When a load is connected, the value in the table is multiplied by $1/(m + 1)$, where $m = \text{load inertia moment/motor inertia moment}$. At the speed higher than the rated, the permissible number of times is in inverse proportion to the square of (running speed/rated speed). When the running speed varies frequently or when the regenerative mode continues as in vertical feed, calculate regenerative heat generated during operation. Provisions must be made to keep this generated heat below the permissible value.
5. If the effective torque is within the rated torque range, there are no restrictions on the regenerative duty.
6. Except for the shaft-through portion and connector end.
7. In the environment where the servo motor is exposed to oil mist, oil and/or water, the servo motor of the standard specifications may not be usable. Contact us.
8. IP54 for the EN Standard-compliant model.
9. Except the connector section.
10. Values for use of the supplied regenerative brake unit (regenerative resistor) are indicated in the case of the 11k to 22kW servo amplifiers. Values for use of the supplied regenerative brake unit (regenerative resistor).
11. 80%ED at low noise.
80%ED: Indicates the condition in which operation time at rated torque accounts for 80% and the other no-load time accounts for 20% in a single operation cycle.

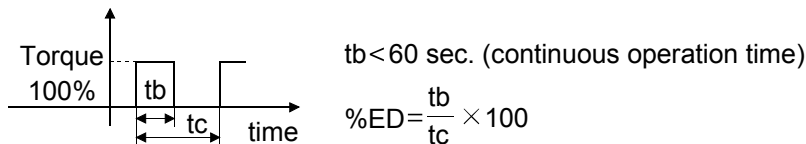

12. When the servo motor is provided with the reduction gear, the protection type of the reduction gear section is IP44.
13. Consult us since they may not be connected depending on the production period of the servo amplifier.
14. Value applicable when the regenerative option is cooled by a cooling fan.
15. The regenerative brake duty of the 600W or less servo amplifier may vary under the influence of the power supply voltage because of the large ratio of the energy for charging the electrolytic capacitor in the servo amplifier.

5. SPECIFICATIONS

5.2 Torque characteristics

POINT
<ul style="list-style-type: none"> ▪ For machines which produce unbalance torque, e.g. vertical lift applications, it is recommended to use the servo motor so that the unbalance torque will be within 70% of the rated torque. ▪ The torque characteristics without notes assume that the power supply is three-phase 200VAC.

(1) HC-MF series

POINT
<ul style="list-style-type: none"> ▪ The continuous broken line in the graph assumes that the servo motor is used with the servo amplifier of single-phase 100VAC power supply specifications.

[HC-MF053]

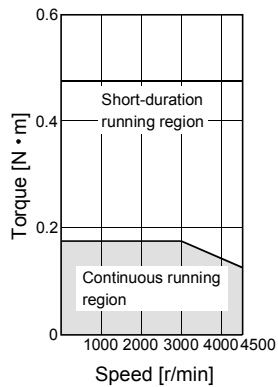

[HC-MF13]

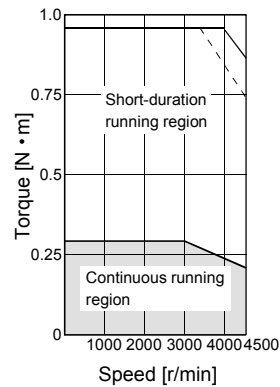

[HC-MF23]

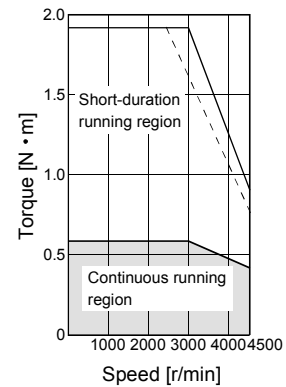

[HC-MF43]

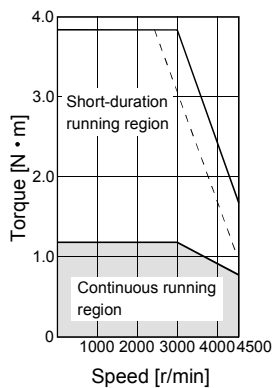

[HC-MF73]

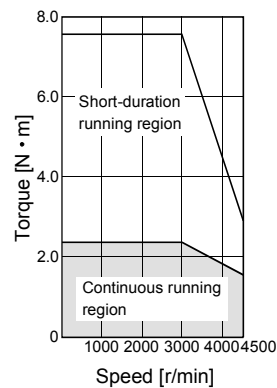

5. SPECIFICATIONS

(2) HA-FF series

POINT

- The continuous broken line in the graph assumes that the servo motor is used with the servo amplifier of single-phase 100VAC power supply specifications.

[HA-FF053]

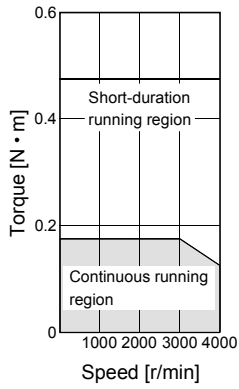

[HA-FF13]

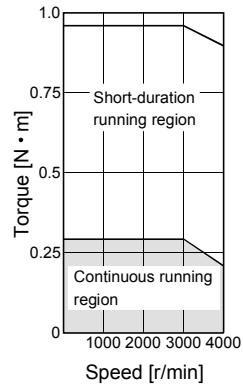

[HA-FF23]

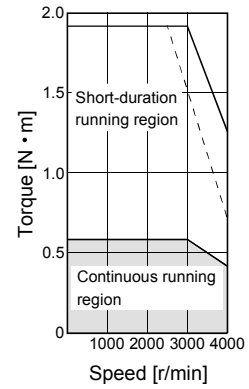

[HA-FF33]

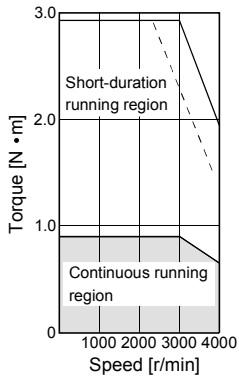

[HA-FF43]

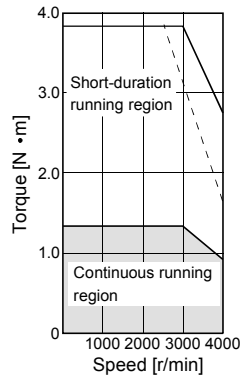

[HA-FF63]

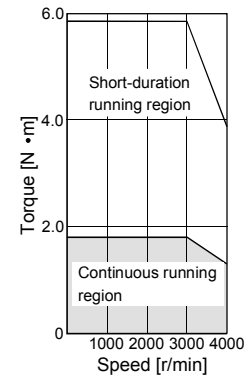

5. SPECIFICATIONS

(3) HC-SF/HC-SFS series

(a) 200VAC-compatible

[HC-SF81] (Note 1)
[HC-SFS81] (Note 1)

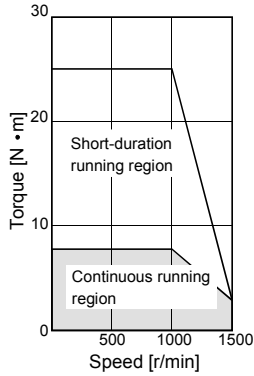

[HC-SF121] (Note 1)
[HC-SFS121] (Note 1)

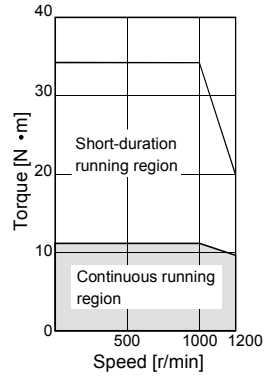

[HC-SF201] (Note 1)
[HC-SFS201] (Note 1)

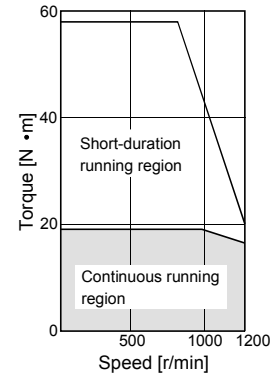

[HC-SF301] (Note 1)
[HC-SFS301] (Note 1)

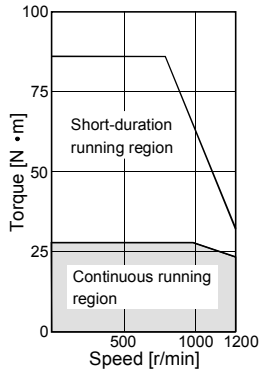

[HC-SF52] (Note 1, 2)
[HC-SFS52] (Note 1, 2)

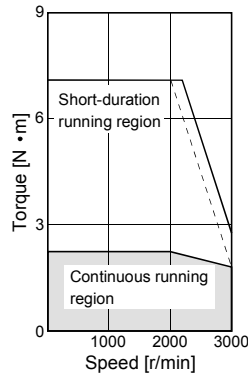

[HC-SF102] (Note 1)
[HC-SFS102] (Note 1)

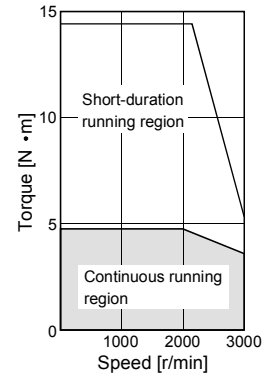

[HC-SF152] (Note 1)
[HC-SFS152] (Note 1)

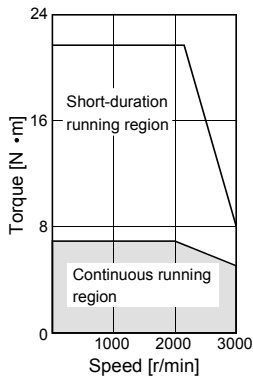

[HC-SF202] (Note 1)
[HC-SFS202] (Note 1)

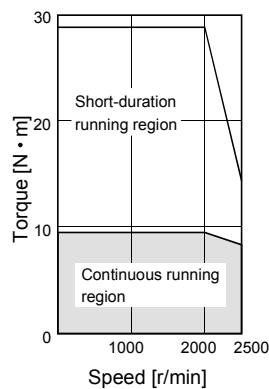

[HC-SF352] (Note 1)
[HC-SFS352] (Note 1)

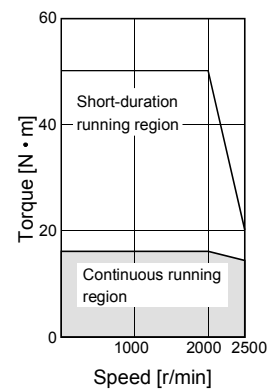

Note 1. The continuous line assumes that the servo amplifier's main circuit power supply is 3-phase 200VAC.

2. The broken line assumes that the servo amplifier's main circuit power supply is 1-phase 230VAC.

Note that only the area different from 3-phase 200VAC is indicated by the broken line.

5. SPECIFICATIONS

[HC-SF502]
[HC-SFS502]

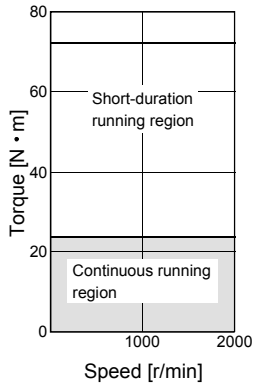

[HC-SF702]
[HC-SFS702]

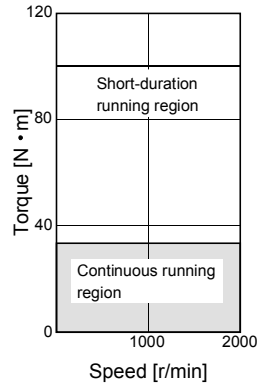

[HC-SF53]
[HC-SFS53]

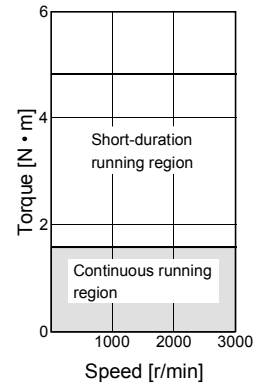

[HC-SF103]
[HC-SFS103]

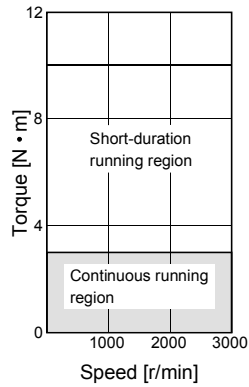

[HC-SF153]
[HC-SFS153]

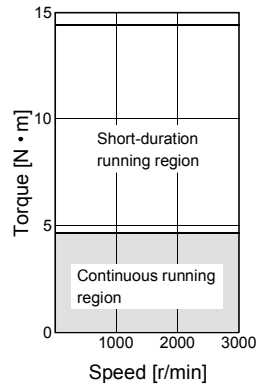

[HC-SF203]
[HC-SFS203]

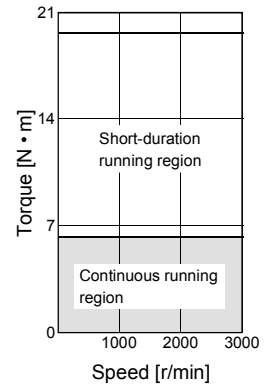

[HC-SF353]
[HC-SFS353]

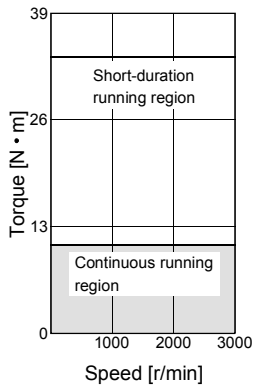

5. SPECIFICATIONS

(b) 400VAC-compatible

[HC-SFS524] (Note 1, 2)

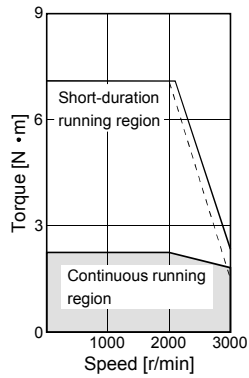

[HC-SFS1024] (Note 1, 2)

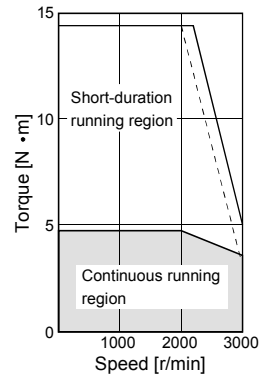

[HC-SFS1524] (Note 1, 2)

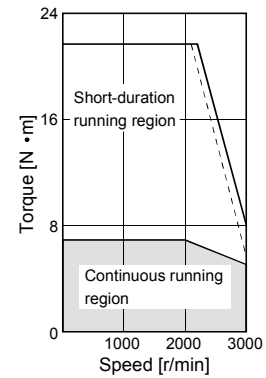

[HC-SFS2024] (Note 1, 2)

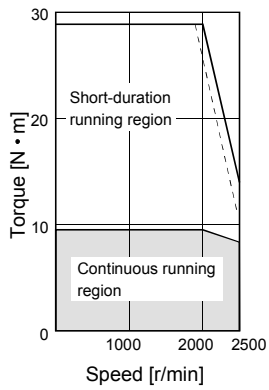

[HC-SFS3524] (Note 1, 2)

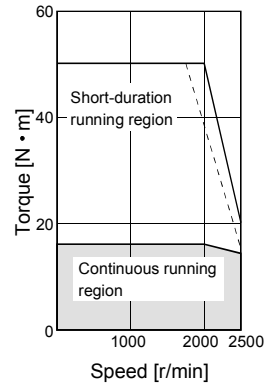

[HC-SFS5024] (Note 1)

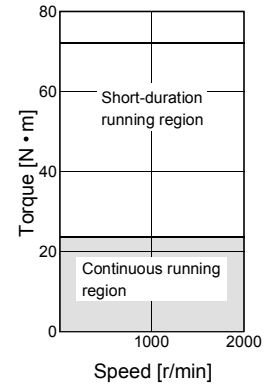

[HC-SFS7024] (Note 1)

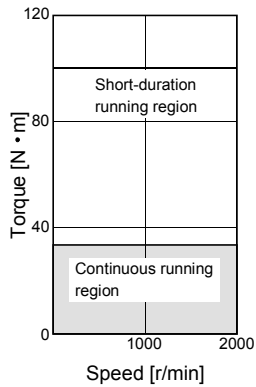

Note 1. The continuous line assumes that the servo amplifier's main circuit power supply is 3-phase 400VAC.

2. The broken line assumes that the servo amplifier's main circuit power supply is 3-phase 380VAC.

Note that only the area different from 3-phase 400VAC is indicated by the broken line.

5. SPECIFICATIONS

(4) HC-RF/HC-RFS series

[HC-RF103]
[HC-RFS103]

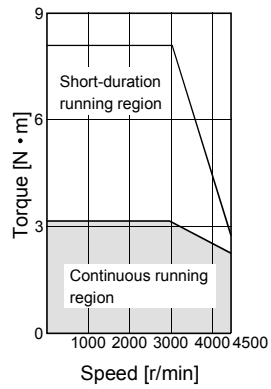

[HC-RF153]
[HC-RFS153]

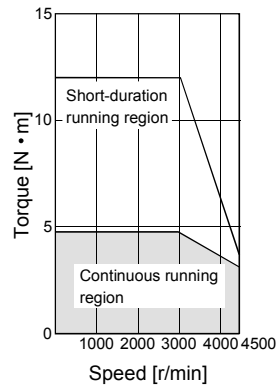

[HC-RF203]
[HC-RFS203]

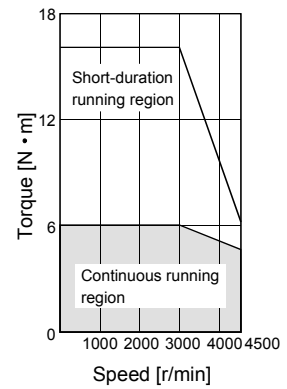

[HC-RF353]
[HC-RFS353]

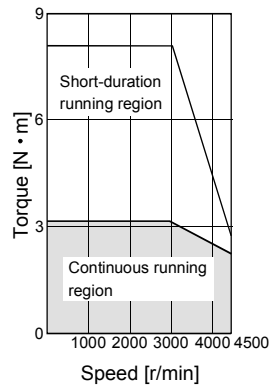

[HC-RF503]
[HC-RFS503]

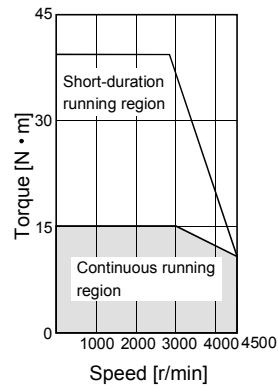

5. SPECIFICATIONS

(5) HC-UF/HC-UFS series

POINT

- The continuous broken line in the graph assumes that the servo motor is used with the servo amplifier of single-phase 100VAC power supply specifications.

[HC-UF72]
[HC-UFS72]

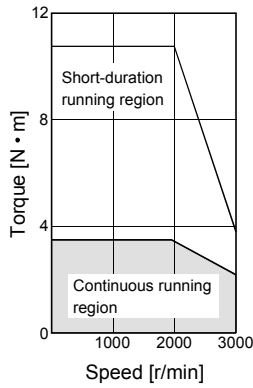

[HC-UF152]
[HC-UFS152]

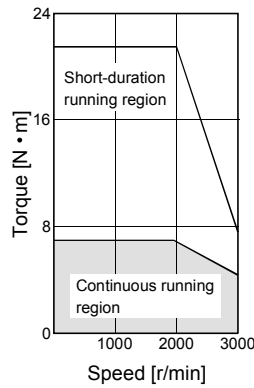

[HC-UF202]
[HC-UFS202]

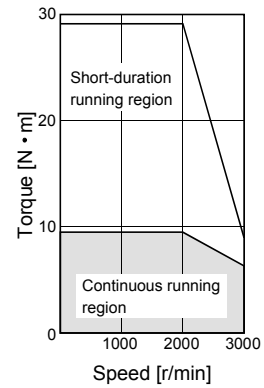

[HC-UF352]
[HC-UFS352]

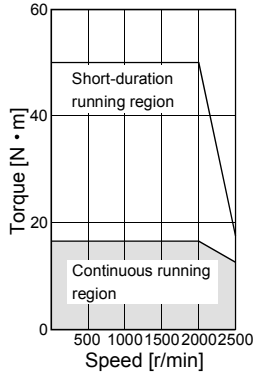

[HC-UF502]
[HC-UFS502]

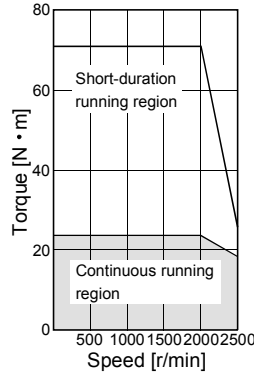

[HC-UF13]

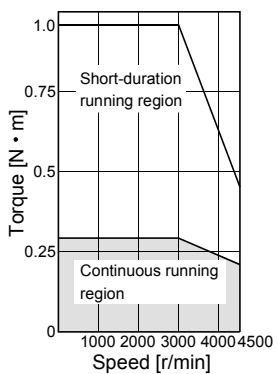

[HC-UF23]

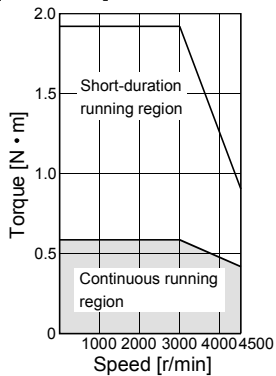

[HC-UF43]

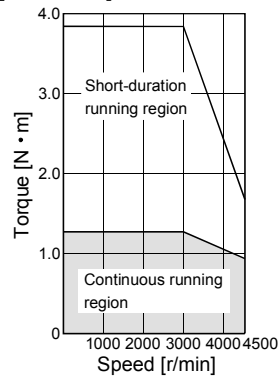

[HC-UF73]

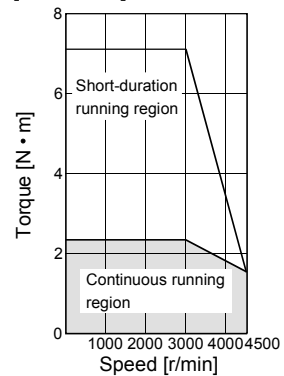

5. SPECIFICATIONS

[HC-UFS13]

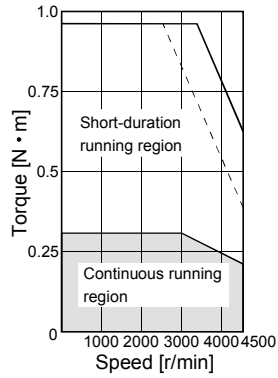

[HC-UFS23]

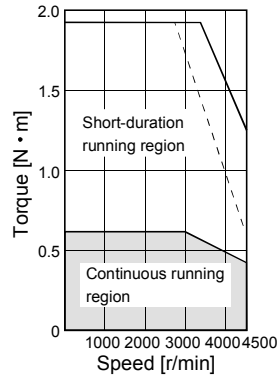

[HC-UFS43]

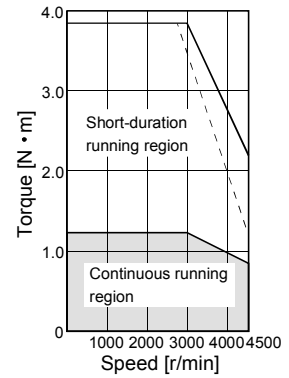

[HC-UFS73]

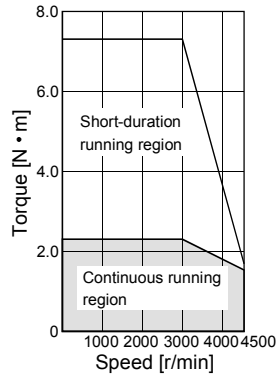

(6) HA-LH series

[HA-LH11K2]

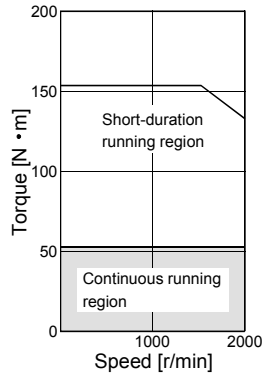

[HA-LH15K2]

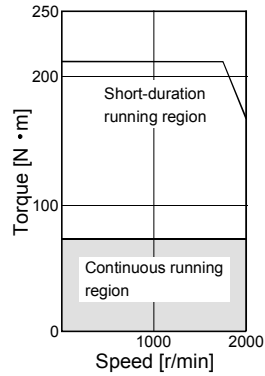

[HA-LH22K2]

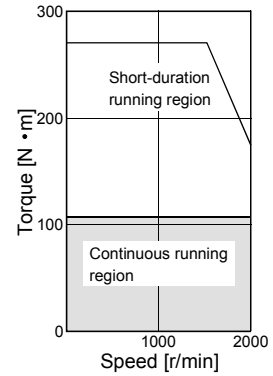

5. SPECIFICATIONS

(7) HC-KF series

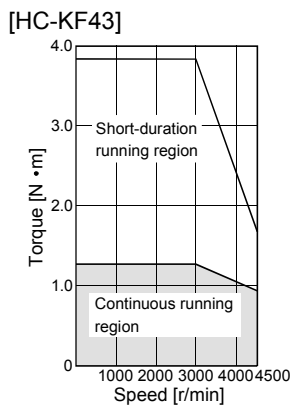
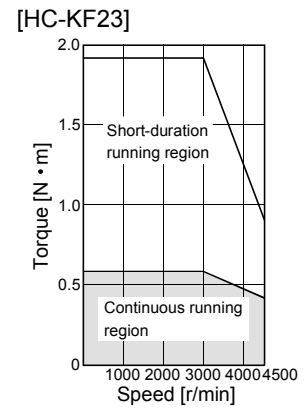
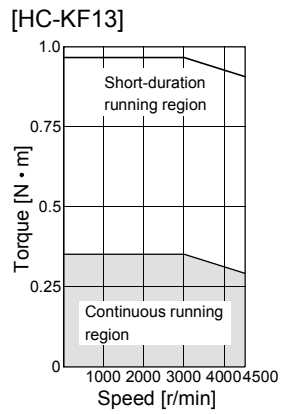
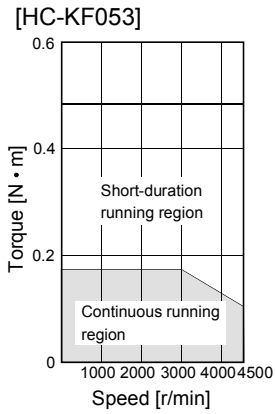

(8) HC-AQ series

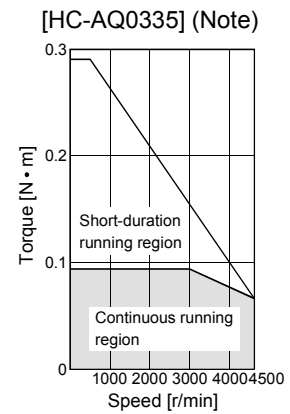
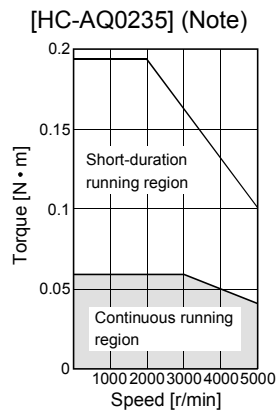
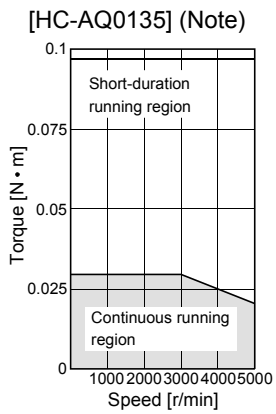

Note. Assumes that the servo amplifier main circuit power supply is 24 VDC.

5. SPECIFICATIONS

(9) HA-LF series

(a) 200VAC-compatible

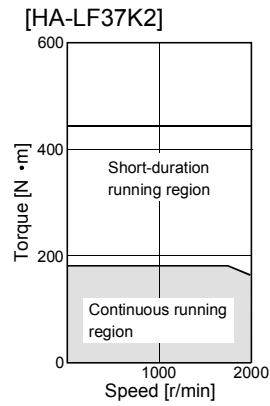
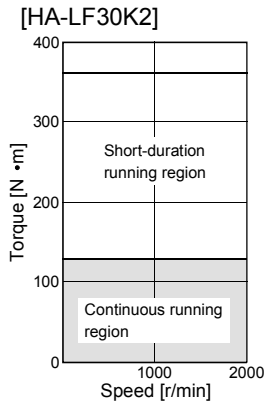

(b) 400VAC-compatible

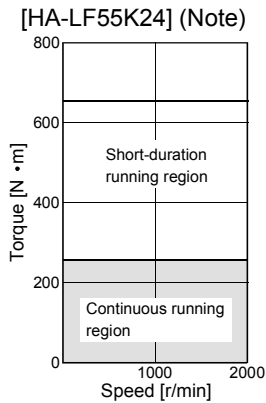
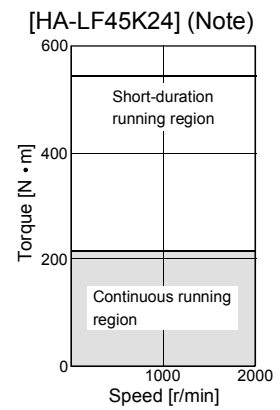
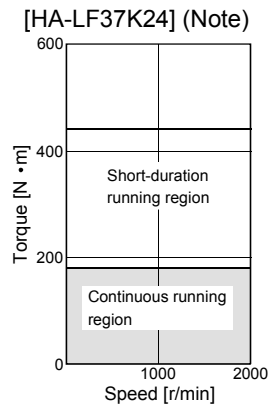
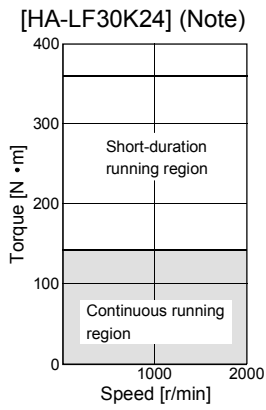

Note. Assumes that the servo amplifier main circuit power supply is three-phase 400 VAC.

5. SPECIFICATIONS

(10) HA-LFS series

(a) 200VAC-compatible

[HA-LFS601]

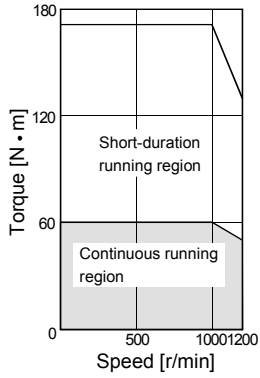

[HA-LFS801]

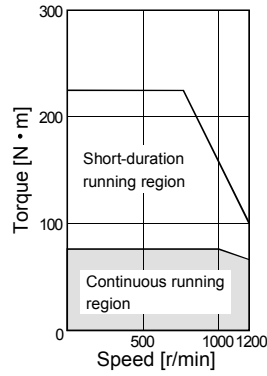

[HA-LFS12K1]

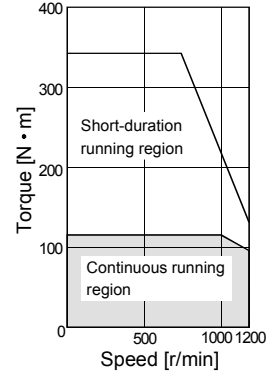

[HA-LFS15K1]

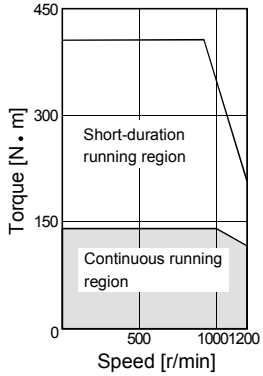

[HA-LFS20K1]

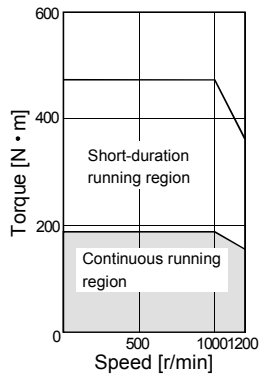

[HA-LFS25K1]

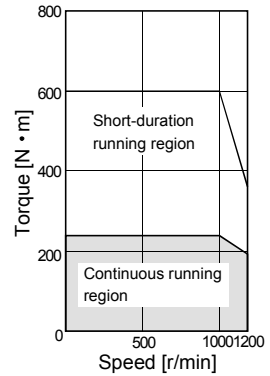

[HA-LFS30K1]

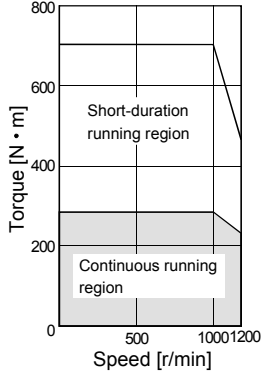

[HA-LFS37K1]

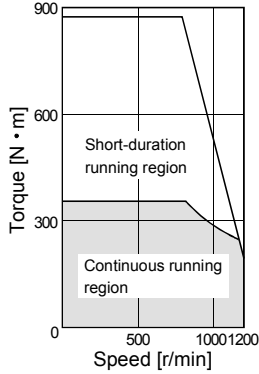

[HA-LFS701M]

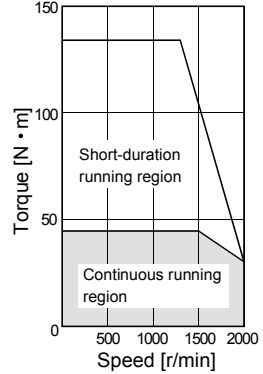

[HA-LFS11K1M]

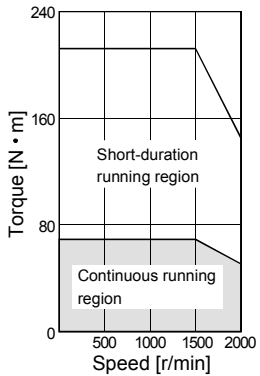

[HA-LFS15K1M]

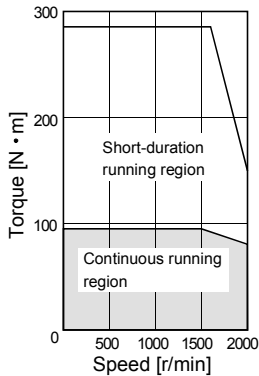

[HA-LFS22K1M]

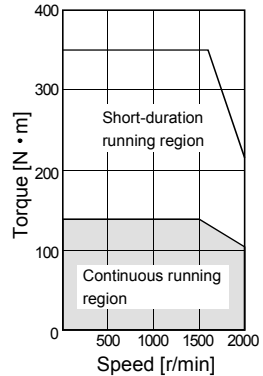

5. SPECIFICATIONS

[HA-LFS30K1M]

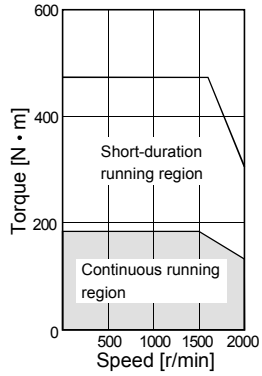

[HA-LFS37K1M]

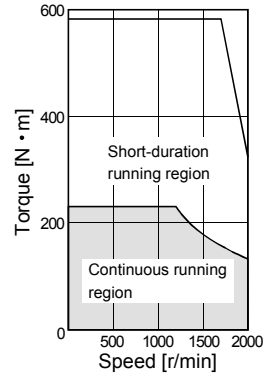

[HA-LFS502]

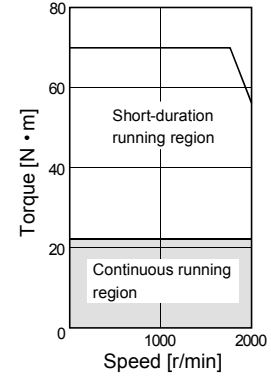

[HA-LFS702]

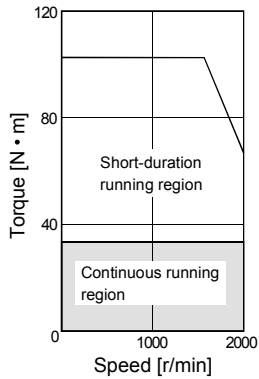

[HA-LFS11K2]

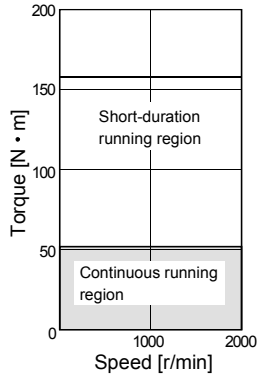

[HA-LFS15K2]

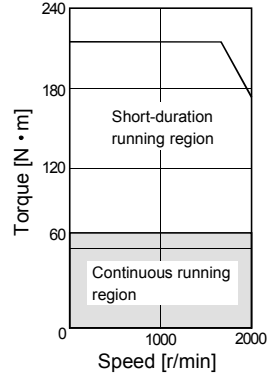

[HA-LFS22K2]

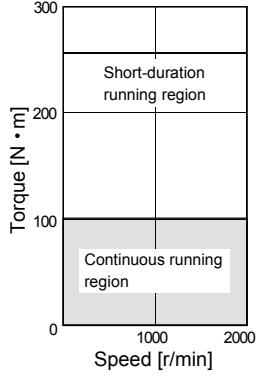

[HA-LFS30K2]

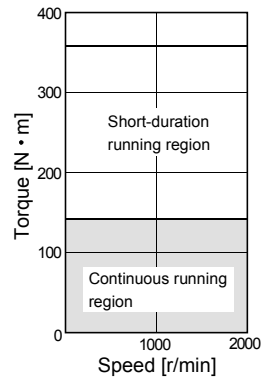

[HA-LFS37K2]

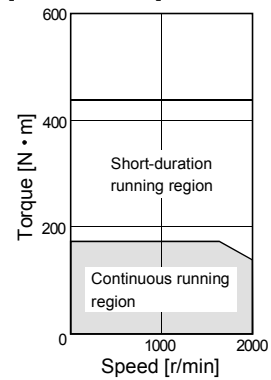

5. SPECIFICATIONS

(b) 400VAC-compatible (Note 1)

[HA-LFS6014 (B)] (Note 1, 2)

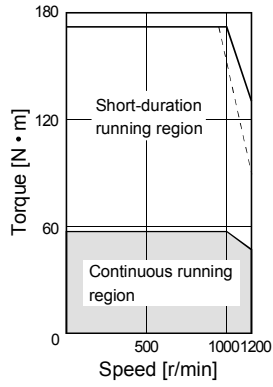

[HA-LFS8014 (B)] (Note 1, 2)

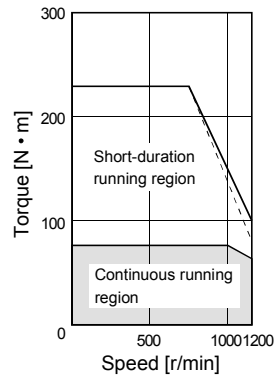

[HA-LFS12K14 (B)] (Note 1, 2)

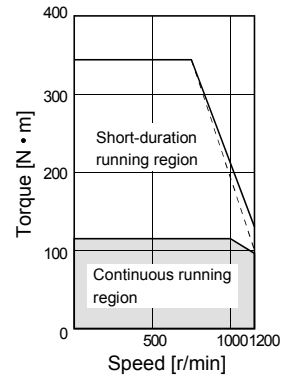

[HA-LFS15K14] (Note 1, 2)

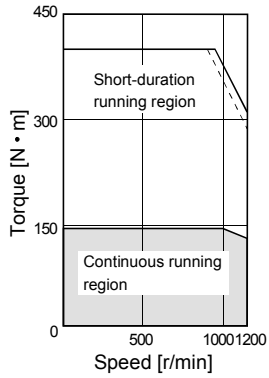

[HA-LFS20K14] (Note 1, 2)

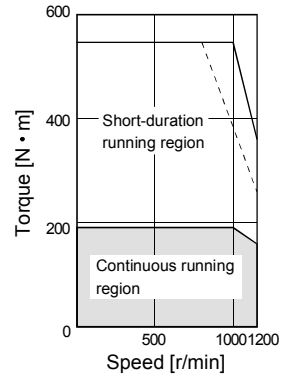

[HA-LFS25K14] (Note 1, 2)

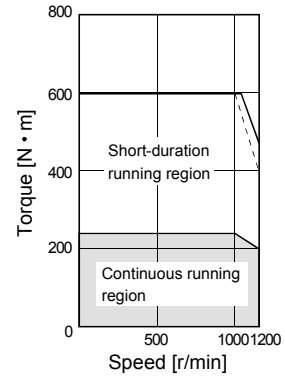

[HA-LFS30K14] (Note 1, 2)

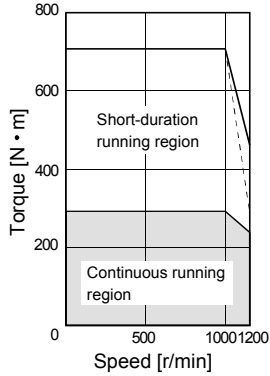

[HA-LFS37K14] (Note 1)

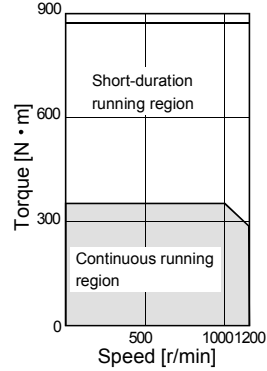

[HA-LFS701M4 (B)] (Note 1, 2)

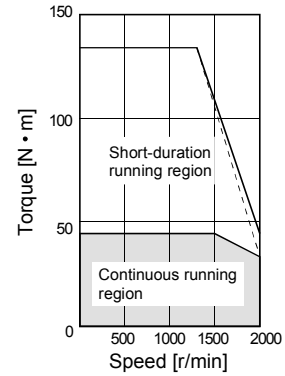

5. SPECIFICATIONS

[HA-LFS11K1M4] (Note 1, 2)

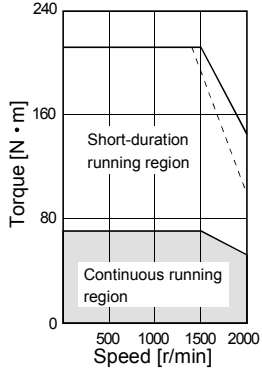

[HA-LFS15K1M4] (Note 1, 2)

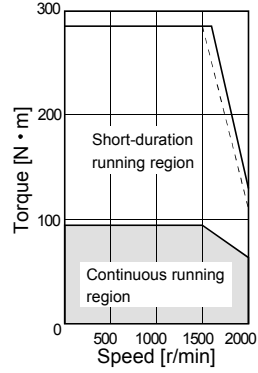

[HA-LFS22K1M4] (Note 1, 2)

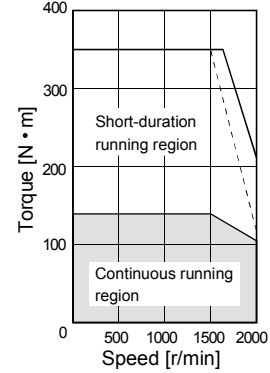

[HA-LFS30K1M4] (Note 1, 2)

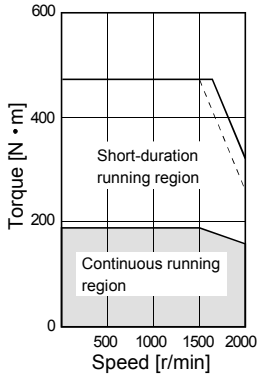

[HA-LFS37K1M4] (Note 1, 2)

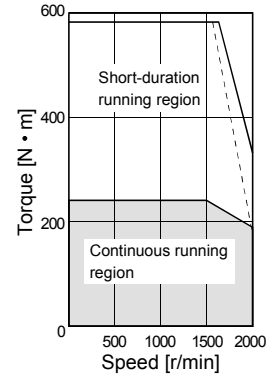

[HA-LFS45K1M4] (Note 1, 2)

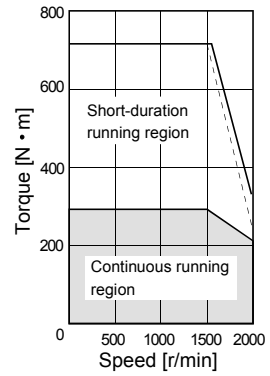

[HA-LFS50K1M4] (Note 1, 2)

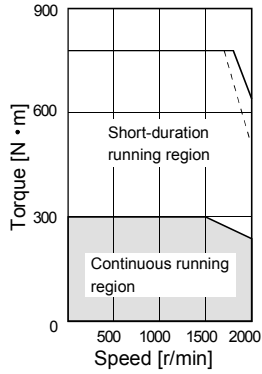

[HA-LFS11K24] (Note 1)

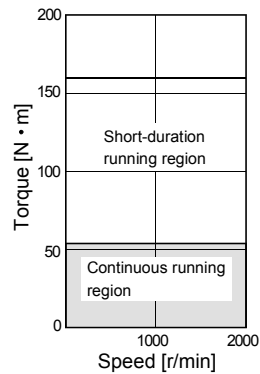

[HA-LFS15K24] (Note 1, 2)

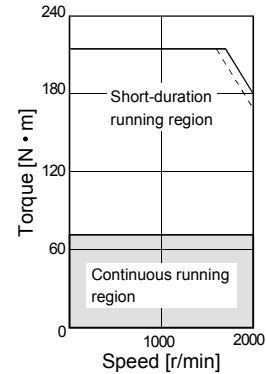

5. SPECIFICATIONS

[HA-LFS22K24] (Note 1)

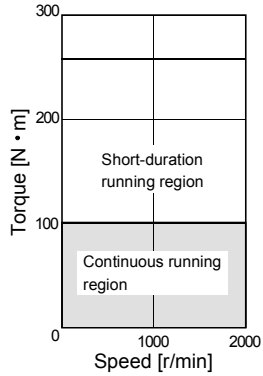

[HA-LFS30K24] (Note 1)

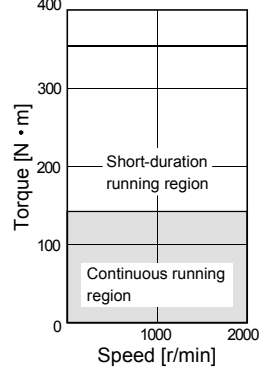

[HA-LFS37K24] (Note 1)

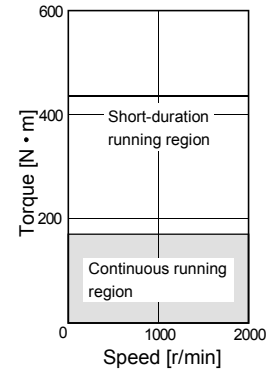

[HA-LFS45K24] (Note 1)

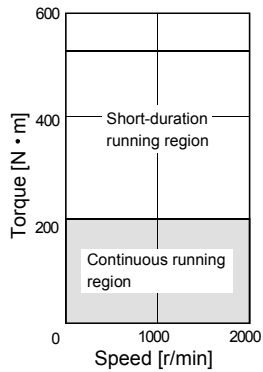

[HA-LFS55K24] (Note 1)

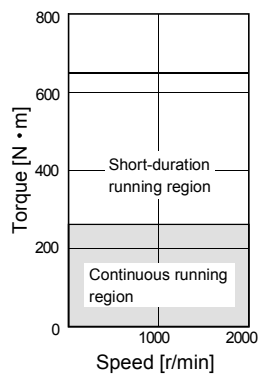

Note 1. The continuous line assumes that the servo amplifier's main circuit power supply is 3-phase 400VAC.

2. The broken line assumes that the servo amplifier's main circuit power supply is 1-phase 230VAC.

Note that only the area different from 3-phase 200VAC is indicated by the broken line.

5. SPECIFICATIONS

(11) HC-MFS series

POINT

- The continuous broken line in the graph assumes that the servo motor is used with the servo amplifier of single-phase 100VAC power supply specifications.

[HC-MFS053]

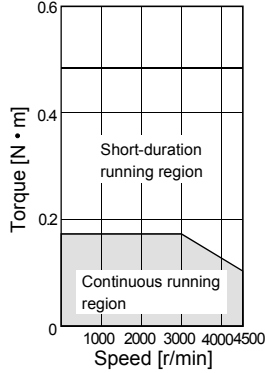

[HC-MFS13]

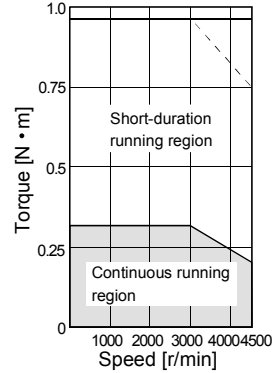

[HC-MFS23]

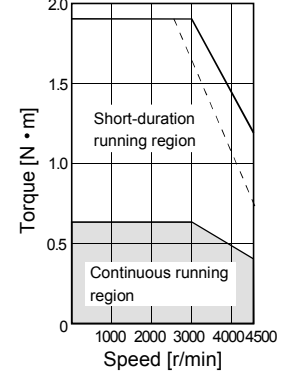

[HC-MFS43]

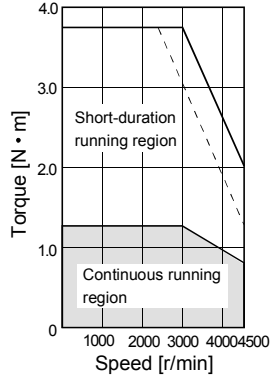

[HC-MFS73]

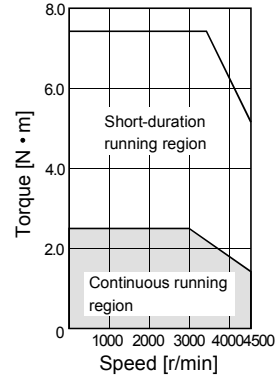

5. SPECIFICATIONS

(12) HC-KFS series

POINT
<ul style="list-style-type: none"> The continuous broken line in the graph assumes that the servo motor is used with the servo amplifier of single-phase 100VAC power supply specifications.

[HC-KFS053]

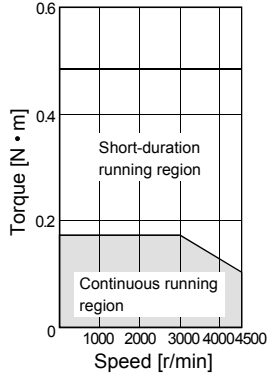

[HC-KFS13]

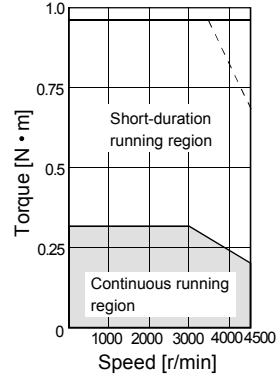

[HC-KFS23]

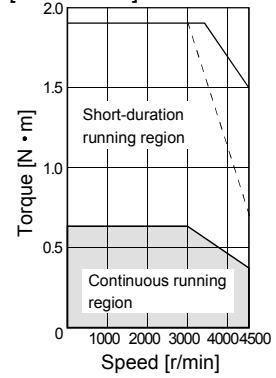

[HC-KFS43]

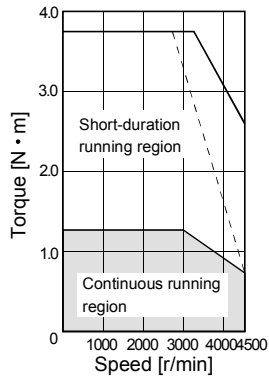

[HC-KFS73]

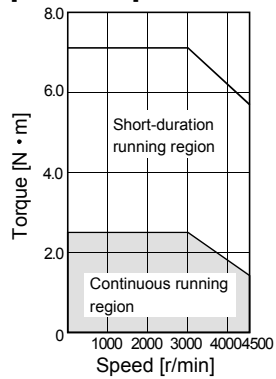

5. SPECIFICATIONS

(13) HC-LFS series

[HC-LFS52]

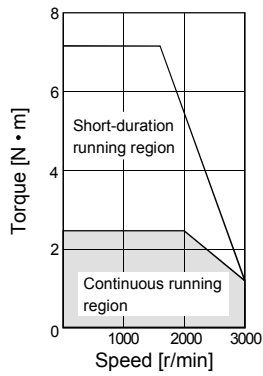

[HC-LFS102]

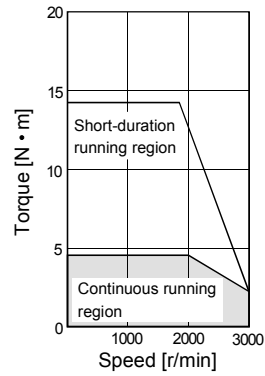

[HC-LFS152]

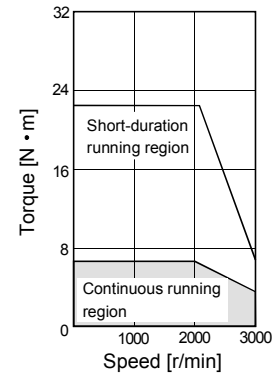

[HC-LFS202]

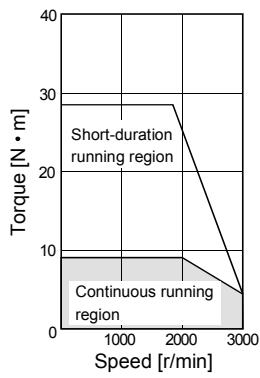

[HC-LFS302]

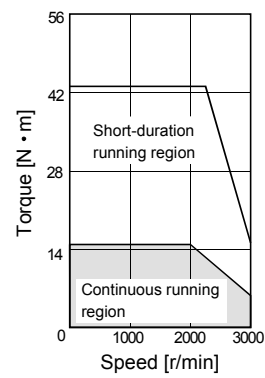

5. SPECIFICATIONS

5.3 Servo motors with reduction gears



CAUTION

- The servo motor with reduction gear must be installed in the specified direction. Otherwise, it can leak oil, leading to a fire or fault.
- For the servo motor with reduction gear, transport it in the same status as in the installation method. Tipping it over can cause oil leakage.

Servo motors are available with reduction gears designed for: general industrial machines and precision applications.

Servo motors with electromagnetic brakes are also available.

(1) Manufacturing range of servo motor with reduction gear

Servo motors with reduction gears that may be manufactured are indicated by symbols (G1 • G1H, G2) in the following table. G1 • G1H and G2 are symbols appended to the servo motor models.

Reduction Gear Series Reduction ratio	For General Industrial Machines											For Precision Applications								
	(Note) 1/5	1/6	(Note) 1/10	1/11	(Note) 1/12	1/17	(Note) 1/20	1/29	(Note) 1/30	1/35	1/43	1/59	1/5	1/9	1/10	1/15	1/20	1/25	1/29	1/45
HC-KF053□ to 43□ HC-KFS053□ to 73□	G1				G1		G1						G2	G2			G2		G2	
HC-MF053□ to 73□ HC-MFS053□ to 73□	G1				G1		G1						G2	G2			G2		G2	
HA-FF053□	G1		G1				G1		G1				G2		G2	G2		G2		
HA-FF13□	G1		G1				G1		G1				G2		G2	G2		G2		G2
HA-FF23□	G1		G1				G1		G1				G2		G2	G2	G2		G2	G2
HA-FF33□	G1		G1				G1		G1				G2		G2		G2		G2	G2
HA-FF43□ • 63□	G1		G1				G1		G1				G2	G2			G2		G2	G2
HC-SF52□ to 202□ HC-SFS52(4)□ to 202(4)□		G1 G1H		G1 G1H		G1 G1H		G1 G1H		G1 G1H	G1 G1H	G1 G1H	G2	G2			G2		G2	G2
HC-SF352□ HC-SFS352(4)□		G1 G1H		G1 G1H		G1 G1H		G1 G1H		G1 G1H	G1 G1H	G1 G1H	G2	G2			G2			
HC-SF502□ HC-SFS502(4)□				G1 G1H		G1 G1H		G1 G1H		G1 G1H	G1 G1H		G2	G2						
HC-SF702□ HC-SFS702(4)□				G1 G1H		G1 G1H		G1 G1H		G1 G1H	G1 G1H		G2							
HC-RF103□ to 203□ HC-RFS103□ to 203□													G2	G2			G2		G2	G2
HC-RF353□ HC-RFS353□													G2	G2			G2		G2	
HC-RF503□ HC-RFS503□													G2	G2			G2			

Note. Reduction ratios for general industrial machines are nominal values. For actual reduction ratios, refer to (2) and (3) in this section.

For those without (Note), the nominal value is equal to the actual reduction ratio.

5. SPECIFICATIONS

(2) HC-MF/HC-KF/HC-MFS/HC-KFS series

Reduction Gear Series		For General Industrial Machines (HC-KF□G1/HC-MF□G1) (HC-KFS□G1/HC-MFS□G1)			For Precision Applications (HC-KF□G2/HC-MF□G2) (HC-KFS□G2/HC-MFS□G2)	
Mounting method		Flange mounting				
Mounting direction		In any directions				
Lubrication method	Packed with	(Note 2) Grease lubrication (Already packed)			(Note 2) Grease lubrication (Already packed)	
		50 ▪ 100W Mobilplex 46 Mobil Oil	200W ▪ 400W 1/12, 1/20 Molynoc AP2 NIPPON OIL CORPORATION	750W 1/12	200W ▪ 400W 1/5 Mobil Grease SP Mobil Oil	750W 1/5, 1/20
Output shaft rotating direction		Same as the servo motor output shaft direction.				
With electromagnetic brake		Available				
Backlash		60 minutes or less at reduction gear output shaft			3 minutes or less at reduction gear output shaft	
(Note 1) Permissible load inertia moment ratio (when converting into the servo motor shaft)		HC-KF ▪ HC-KFS When 50W ▪ 100W ▪ 750W used: 5 times or less When 200W ▪ 400W used: 7 times or less HC-MF ▪ HC-MFS: 25 times or less			HC-KF ▪ HC-KFS When 50W ▪ 100W ▪ 750W used: 5 times or less When 200W ▪ 400W used: 7 times or less HC-MF ▪ HC-MFS: 25 times or less	
Permissible speed (at servo motor shaft)		4500 r/min				
Reduction gear efficiency (Note 3)		45 to 75%			60 to 80%	

Note 1. If the above indicated value is exceeded, please consult us.

2. Maintenance-free.

3. The reduction gear efficiency differs depending on the reduction ratio.

Also, it changes depending on the use conditions such as the output torque, speed and rotation, temperature, etc. The numerical value in the table is a typical value in the rated torque, rated speed and rotation and typical temperature, and not a guaranteed value.

The actual reduction ratios of the servo motors with reduction gears designed for general industrial machines are as listed below.

Nominal Reduction Ratio	Servo Motor	HC-KF053(B)G1 HC-MF053(B)G1 HC-KFS053(B)G1 HC-MFS053(B)G1	HC-KF13(B)G1 HC-MF13(B)G1 HC-KFS13(B)G1 HC-MFS13(B)G1	HC-KF23(B)G1 HC-MF23(B)G1 HC-KFS23(B)G1 HC-MFS23(B)G1	HC-KF43(B)G1 HC-MF43(B)G1 HC-KFS43(B)G1 HC-MFS43(B)G1	HC-KFS73(B)G1 HC-MF73(B)G1 HC-MFS73(B)G1
	1/5	9/44		19/96		1/5
1/12	49/576		25/288		525/6048	
1/20	25/484		253/5000		625/12544	

5. SPECIFICATIONS

(3) HA-FF series

Reduction Gear Series		For General Industrial Machines (HA-FF□G1)		For Precision Applications (HA-FF□G2)
Mounting method		Flange mounting		
Mounting direction		In any directions		
Lubrication method	Packed with	(Note 3) Grease lubrication (Already packed)		(Note 3) Grease lubrication (Already packed)
		50 • 100W	200 to 600W	LOR#101BV Oil Center Research
		SUMICO LUBRICANT MOLY PS GREASE No.2	PYRONOC UNIVERSAL No.000 NIPPON PETROLEUM	
Output shaft rotating direction		Servo motor shaft and reduction gear output shaft rotate in the same direction. For the HA-FF053G1 1/30 and HA-FF3G1 1/30, however, the servo motor shaft and reduction gear output shaft rotate in the opposite directions.	Servo motor shaft and reduction gear output shaft rotate in the same direction.	
With electromagnetic brake		Available		
Backlash		(Note 1) 40 minutes to 1.5°	Within 3 minutes	
(Note 2) Permissible load inertia moment ratio (when converting into the servo motor shaft)		5 times or less		
Permissible speed (at servo motor shaft)		3000 r/min		
Reduction gear efficiency (Note 4)		73 to 85%	80 to 90%	

Note 1. The above values are typical values and not guaranteed values.

2. If the above indicated value is exceeded, please consult us.

3. Maintenance-free.

4. The reduction gear efficiency differs depending on the reduction ratio.

Also, it changes depending on the use conditions such as the output torque, speed and rotation, temperature, etc. The numerical value in the table is a typical value in the rated torque, rated speed and rotation and typical temperature, and not a guaranteed value.

The actual reduction ratios of the servo motors with reduction gears designed for general industrial machines are as listed below.

Nominal Reduction Ratio	Servo Motor					
	HA-FF053G1	HA-FF13G1	HA-FF23G1	HA-FF33G1	HA-FF43G1	HA-FF63G1
1/5	9/44		57/280		19/94	10/49
1/10	3/29		39/400		39/376	243/2401
1/20	99/1972		51/980		72/1363	153/2891
1/30	144/4205		1/30		11/329	27/784

5. SPECIFICATIONS

(4) HC-SF/HC-SFS series

Reduction Gear Series		For General Industrial Machines (HC-SF□G1(H)/HC-SFS□G1(H))	For Precision Applications (HC-SF□G2/ HC-SFS□G2)
Mounting method		As in (a) in this section	Flange mounting
Mounting direction		As in (a) in this section	In any directions
Lubrication method		As in (a) · (b) in this section	(Note 4) Grease lubrication (Already packed)
	(Note 2) Recommended products	As in (b) in this section	LOR#101BV Oil Center Research
Output shaft rotating direction		Opposite direction to the servo motor shaft	Same direction as the servo motor shaft
With electromagnetic brake		Available	
Backlash		40 minutes to 2*at reduction gear output shaft (Note 1)	3 minutes or less at reduction gear output shaft
(Note 3) Permissible load inertia moment ratio (when converting into the servo motor shaft)		4 times or less	5 times or less
Permissible speed (at servo motor shaft)		2000 r/min	0.5 to 1.5kW:3000 r/min 2 to 3.5kW:2500 r/min 5 · 7kW:2000 r/min
Reduction gear efficiency (Note 5)		85 to 94%	80 to 90%

Note 1. The above values are typical values and not guaranteed values.

2. For grease lubrication, the reduction gear is already grease-packed.
3. If the above indicated value is exceeded, please consult us.
4. Maintenance-free.
5. The reduction gear efficiency differs depending on the reduction ratio.

Also, it changes depending on the use conditions such as the output torque, speed and rotation, temperature, etc. The numerical value in the table is a typical value in the rated torque, rated speed and rotation and typical temperature, and not a guaranteed value.

(a) Lubrication of reduction gears for general industrial machines

Oil lubrication cannot be used in applications where the servo motor will move. Specify grease lubrication.

For grease lubrication, the reduction gear is already grease-packed.

For oil lubrication, pack the reduction gear with oil on the customer side.

Mounting Direction Reduction gear model Reduction gear frame No.	Shaft in Any Direction		Shaft Horizontal		Shaft Downward		Shaft Upward	
	CNHM (leg type)	CNVM (flange type)	CHHM (leg type)	CHVM (flange type)	CVHM (leg type)	CVVM (flange type)	CWHM (leg type)	CWVM (flange type)
4105	Grease	Grease						
4115	Grease	Grease						
4135			(Note) Oil	(Note) Oil	(Note) Oil	(Note) Oil	Grease	Grease
4165			(Note) Oil	(Note) Oil	(Note) Oil	(Note) Oil	Grease	Grease
4175			Oil	Oil	Oil	Oil		
4185			Oil	Oil	Oil	Oil		
4195			Oil	Oil	Oil	Oil		

Note. Grease-lubricated type is also available optionally.

5. SPECIFICATIONS

The reduction gear frame numbers are as follows.

Servo Motor	Reduction Ratio						
	1/6	1/11	1/17	1/29	1/35	1/43	1/59
HC-SF52(B)G1 (H) HC-SFS52(B)G1 (H) HC-SFS524(B)G1 (H)	4105				4115		
HC-SF102(B)G1 (H) HC-SFS102(B)G1 (H) HC-SFS1024(B)G1 (H)	4115					4135	4165
HC-SF152(B)G1 (H) HC-SFS152(B)G1 (H) HC-SFS1524(B)G1 (H)	4115			4135		4165	
HC-SF202(B)G1 (H) HC-SFS202(B)G1 (H) HC-SFS2024(B)G1 (H)	4115			4165			
HC-SF352(B)G1 (H) HC-SFS352(B)G1 (H) HC-SFS3524(B)G1 (H)	4135			4165		4175	
HC-SF502(B)G1 (H) HC-SFS502(B)G1 (H) HC-SFS5024(B)G1 (H)		4165			4185		
HC-SF702(B)G1 (H) HC-SFS702(B)G1 (H) HC-SFS7024(B)G1 (H)		4175		4185		4195	

(b) Recommended lubricants

1) Grease

Albania Grease/Shell OIL

2) Lubricating oil

POINT
<ul style="list-style-type: none"> Since the oil-lubricated models are shipped without oil, make sure to fill oil up to the upper red line of the oil gauge before operation.

Ambient Temperature °C	COSMO OIL	NIPPON OIL CORPORATION	IDEMITSU KOSAN CO., LTD	Shell OIL	ESSO OIL GENERAL OIL	Mobil OIL	Japan Energy
-10 to 5	COSMO GEAR SE68	BONNOC M68 DIAMOND GEAR LUBE SP68	DAPHNE SUPER GEAR OIL 68	Omala Oils 68	SPARTAN EP68	Mobilgear 626 (ISO VG68)	JOMO Reductus 68
0 to 35	COSMO GEAR SE100 · 150	BONNOC M100 · 150 DIAMOND GEAR LUBE SP100 · 150	DAPHNE SUPER GEAR OIL 100 · 150	Omala Oils 100 · 150	SPARTAN EP100 · 150	Mobilgear 627 · 629 (ISO VG100 · 150)	JOMO Reductus 100 · 150
30 to 50	COSMO GEAR SE200 · 320 · 460	BONNOC M200 to 460 DIAMOND GEAR LUBE SP220 to 460		Omala Oils 200 to 460	SPARTAN EP220 to 460	Mobilgear 630 to 634 (ISO VG220 to 460)	JOMO Reductus 200 to 460

Lubricating oil fill amount (ℓ)

Reduction gear frame No.	Fill amount [ℓ]	
	Horizontal type	Vertical type
4135	0.7	1.1
4165	1.4	1.0
4175	1.9	1.9
4185	2.5	2.0
4195	4.0	2.7

5. SPECIFICATIONS

(c) Changing intervals of lubricant for general industrial machines

1) Grease

Maintenance-free. (Limited to the case where the grease-lubricated type is standard.)

2) Lubricant

Changing intervals	Operation hours per day	
	Less than 10 hours	10 to 24 hours
First time	500 hours	
Second time and later	Half year	2500 hours

(5) HC-RF/HC-RFS series

Reduction Gear Series	For Precision Applications (HC-RF□G2/HC-RFS□G2)
Mounting method	Flange mounting
Mounting direction	In any directions
Lubrication method	(Note 2) Grease lubrication (Already packed)
Packed with	LOR#101BV Oil Center Research
Output shaft rotating direction	Same direction as the servo motor shaft
With electromagnetic brake	Available
Backlash	Within 3 minutes at reduction gear output shaft
(Note 1) Permissible load inertia moment ratio (when converting into the servo motor shaft)	5 times or less
Permissible speed (at servo motor shaft)	4000 r/min
Reduction gear efficiency (Note 3)	80 to 90%

Note 1. If the above indicated value is exceeded, please consult us.

2. Maintenance-free.

3. The reduction gear efficiency differs depending on the reduction ratio.

Also, it changes depending on the use conditions such as the output torque, speed and rotation, temperature, etc. The numerical value in the table is a typical value in the rated torque, rated speed and rotation and typical temperature, and not a guaranteed value.

5. SPECIFICATIONS

5.4 Servo motors with special shafts

The standard shaft of the servo motor is straight without a keyway. Shafts with keyway and D cut are also available. Except for the servo motor with reduction gear.

These shafts are not appropriate for applications where the servo motor is started and stopped frequently. Use a friction coupling or the like with such keys since we cannot guarantee such trouble as broken shafts due to loose keys.

Servo Motor Model	Shaft Shape		
	Keyway	D cut	Straight
HC-MF053 · 13 HC-MFS053 · 13		○	(Note 4) ○
HC-MF23 to 73 HC-MFS23 to 73	(Note 1) ○		(Note 4) ○
HA-FF053 · 13		○	(Note 4) ○
HA-FF23 to 63	(Note 3) ○		(Note 4) ○
HC-SF81 to 301 HC-SF52 to 702 HC-SF53 to 353 HC-SFS81 to 301 HC-SFS52 to 702 HC-SFS53 to 353 HC-SFS524 to 7024	(Note 2) ○		(Note 4) ○

Servo Motor Model	Shaft Shape		
	Keyway	D cut	Straight
HC-RF103 to 503 HC-RFS103 to 503	(Note 2) ○		(Note 4) ○
HC-UF72 to 502 HC-UFS72 to 502	(Note 2) ○		(Note 4) ○
HC-UF13 HC-UFS13		○	(Note 4) ○
HC-UF23 to 73 HC-UFS23 to 73	(Note 1) ○		(Note 4) ○
HC-KF053 · 13 HC-KFS053 · 13		○	(Note 4) ○
HC-KF23 · 43 HC-KFS23 to 73	(Note 1) ○		(Note 4) ○
HC-AQ0135 to 0335		(Note 4) ○	○
HC-LFS	(Note 2) ○		(Note 4) ○
HA-LA HA-LFS	(Note 2) ○		(Note 4) ○

Note 1. With a key.

2. Without a key.

3. Standard with a key. For shape, refer to chapter 7.

4. This is a standard. For shape, refer to chapter 7.

5.4.1 Keyway

(1) With key

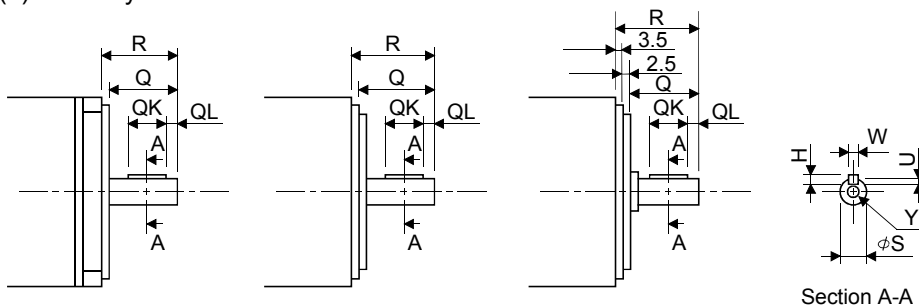

HC-MF(S)23K to 73K

HC-UF(S)23K · 43K

HC-UF(S) 73K

HC-KF23K · 43K

HC-KFS23K to 73K

[Unit: mm]
([Unit: in])

Servo Motor Model	Variable Dimensions								
	S	R	Q	W	QK	QL	U	H	Y
HC-MF23K · 43K HC-MFS23K · 43K	14h6 (14)	30 (1.18)	27 (1.06)	5 (0.20)	20 (0.79)	3 (0.12)	3 (0.12)	5 (0.20)	M4 Depth 15 (0.59)
HC-MF73K HC-MFS73K	19h6 (19)	40 (1.57)	37 (1.46)	6 (0.24)	25 (0.98)	5 (0.20)	3.5 (0.14)	6 (0.24)	M5 Depth 20 (0.79)
HC-UF23K · 43K HC-UFS23K · 43K	14h6 (14)	30 (1.18)	23.5 (0.93)	5 (0.20)	20 (0.79)	3 (0.12)	3 (0.12)	5 (0.20)	M4 Depth 15 (0.59)
HC-UF73K HC-UFS73K	19h6 (19)	40 (1.57)	32.5 (1.28)	6 (0.24)	25 (0.98)	5 (0.20)	3.5 (0.14)	6 (0.24)	M5 Depth 20 (0.79)
HC-KF23K · 43K HC-KFS23K · 43K	14h6 (14)	30 (1.18)	27 (1.06)	5 (0.20)	20 (0.79)	3 (0.12)	3 (0.12)	5 (0.20)	M4 Depth 15 (0.59)
HC-KFS73K	19h6 (19)	40 (1.57)	37 (1.46)	6 (0.24)	25 (0.98)	5 (0.20)	3.5 (0.14)	6 (0.24)	M5 Depth 20 (0.79)

5. SPECIFICATIONS

(2) Without key

[Unit: mm]
([Unit: in])

Servo Motor Model	Variable Dimensions								Drawing
	S	R	Q	W	QK	QL	U	r	
HC-SF81K HC-SF52K to 152K HC-SF53K to 153K HC-SFS81K HC-SFS52(4)K to 152(4)K HC-SFS53K to 153K HC-LFS52K to 152K	24h6 (0.94)	55 (2.17)	50 (1.97)	$8_{-0.036}^0$ (0.31)	36 (1.42)	5 (0.20)	$4_0^{+0.2}$ (0.16)	4 (0.16)	A
HC-SF121K to 301K HC-SF202K to 702K HC-SF203K • 353K HC-SFS121K to 301K HC-SFS202(4)K to 702(4)K HC-SFS203K • 353K HC-LFS202K • 302K	$35_0^{+0.010}$ (1.38)	79 (3.11)	75 (2.95)	$10_{-0.036}^0$ (0.39)	55 (2.17)	5 (0.20)	$5_0^{+0.2}$ (0.20)	5 (0.20)	
HC-RF103K to 203K HC-RFS103K to 203K	24h6 (0.94)	45 (1.79)	40 (1.57)	$8_{-0.036}^0$ (0.31)	25 (0.98)	5 (0.20)	$4_0^{+0.2}$ (0.16)	4 (0.16)	
HC-RF353K to 503K HC-RFS353K to 503K	28h6 (1.10)	63 (2.48)	58 (2.28)	$8_{-0.036}^0$ (0.31)	45 (1.77)	3 (0.12)	$4_0^{+0.2}$ (0.16)	4 (0.16)	
HC-UF72K HC-UFS72K	22h6 (0.87)	55 (2.17)	50 (1.97)	$6_{-0.036}^0$ (0.24)	42 (1.65)	3 (0.12)	$3.5_0^{+0.1}$ (0.14)	3 (0.12)	
HC-UF152K HC-UFS152K	28h6 (1.10)	55 (2.17)	50 (1.97)	$8_{-0.036}^0$ (0.31)	40 (1.58)	5 (0.20)	$4_0^{+0.2}$ (0.16)	4 (0.16)	
HC-UF202K to 502K HC-UFS202K to 502K	$35_0^{+0.010}$ (1.38)	65 (2.56)	60 (2.36)	$10_{-0.036}^0$ (0.39)	50 (1.97)	5 (0.20)	$5_0^{+0.2}$ (0.20)	5 (0.20)	

[Unit: mm]
([Unit: in])

Servo Motor Model	Variable Dimensions									Drawing
	S	R	Q	W	QK	QL	U	r	Y	
HA-LFS502K • 702K • 11K2(4)K HA-LFS601(4)K HA-LFS701M(4)K	42h6 (1.65)	85 (3.35)	80 (3.15)	$12_{-0.04}^0$ (0.47)	70 (2.76)	5 (0.20)	$5_0^{+0.2}$ (0.20)	6 (0.24)	Same as the straight shaft of the standard motor.	A
HA-LFS801(4)K • 12K1(4)K HA-LFS11K1M(4)K • 15K1M(4)K HA-LFS15K2(4)K • 22K2(4)K	55m6 (2.17)	110 (4.33)	100 (3.94)	$16_{-0.04}^0$ (0.63)	90 (3.54)	5 (0.20)	$6_0^{+0.2}$ (0.24)	8 (0.31)		
HA-LF30K2(4)K • 37K2(4)K HA-LFS15K1(4)K • 20K1(4)K HA-LFS22K1M(4)K • 30K1M(4)K HA-LFS30K2(4)K • 37K2(4)K	60m6 (2.36)	140 (5.51)	140 (5.51)	$18_{-0.04}^0$ (0.71)	128 (5.04)	6 (0.24)	$7_0^{+0.2}$ (0.28)	9 (0.35)		
HA-LF45K24K • 55K24K HA-LFS25K1(4)K • 30K1(4)K HA-LFS37K1M(4)K • 45K1M4K HA-LFS45K24K • 55K24K	65m6 (2.56)	140 (5.51)	140 (5.51)	$18_{-0.04}^0$ (0.71)	128 (5.04)	6 (0.24)	$7_0^{+0.2}$ (0.28)	9 (0.35)	B	
HA-LFS37K1(4)K HA-LFS50K1M4K	80m6 (3.15)	170 (6.69)	170 (6.69)	$22_{-0.04}^0$ (0.87)	147 (5.79)	11 (0.43)	$9_0^{+0.2}$ (0.35)	11 (0.43)		

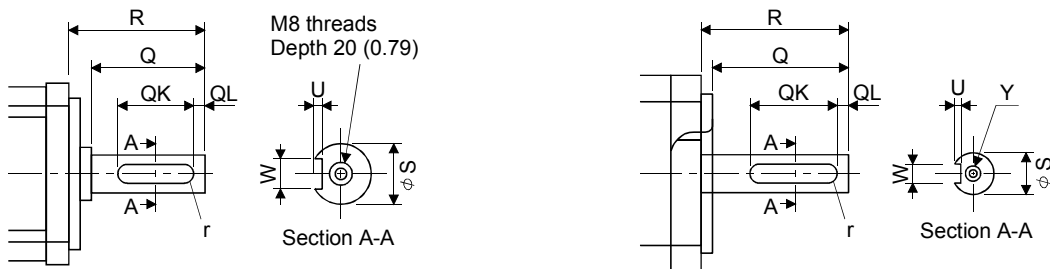

5. SPECIFICATIONS

5.4.2 D cut

[Unit: mm]
([Unit: in])

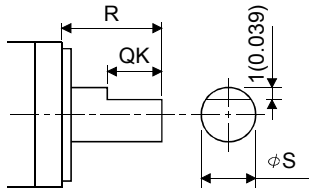

Servo Motor Model	Variable Dimensions		
	R	QK	S
HC-KF053D · 13D	25(0.98)	20.5(0.81)	8h(0.32)
HC-KFS053D · 13D			
HC-MF053D · 13D			
HC-MFS053D · 13D			
HA-FF053D · 13D	30(1.178)	25.5(1.00)	8h(0.32)
HC-UF13D	25(0.98)	17.5(0.69)	8h(0.32)
HC-UFS13D			

5.4.3 Straight (HC-AQ)

[Unit: mm]
([Unit: in])

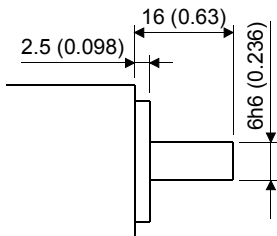

6. CHARACTERISTICS

6. CHARACTERISTICS

6.1 Electromagnetic brake characteristics

▪ Configure the electromagnetic brake circuit so that it is activated not only by the servo amplifier signals but also by an external emergency (forced) stop signal.



CAUTION

Contacts must be open when servo-on signal is off, when an alarm (trouble) is present and when an electromagnetic brake signal.

Circuit must be opened during emergency (force) stop.

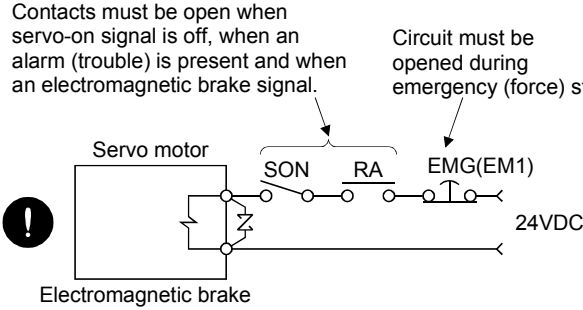

▪ The electromagnetic brake is designed to hold a load. Do not use it for braking.

The characteristics of the electromagnetic brake provided for the servo motor with electromagnetic brake are indicated below:

Table 6.1 Electromagnetic Brake Characteristics

Item	Servo Motor	HC-MF Series HC-MFS Series			HA-FF Series			
		053B · 13B	23B · 43B	73B	053B · 13B	23B · 33B	43B · 63B	
Type (Note 1)		Spring-loaded safety brake						
Rated voltage (Note 4)		24V ⁰ _{-10%} DC						
Power consumption	[W]20°C (68°F)	6.3	7.9	9	7	7.4	11	
Brake static friction torque	[N · m]	0.32	1.3	2.4	0.39	1.18	2.3	
	[oz · in]	45.3	184.2	340	55.3	167	326	
Release delay time (Note 2)	[s]	0.03	0.03	0.03	0.03	0.03	0.03	
Braking delay time [s] (Note 2)	DC off	0.01	0.02	0.03	0.01	0.03	0.03	
	Permissible braking work	Per braking	[J]	5.6	22.0	64.0	3.9	18.0
[oz · in]			793.6	3117.6	9069.3	552.7	2550.7	6518.6
Per hour		[J]	56	220	640	39	180	460
		[oz · in]	7936	31176	90693	5527	25507	65186
Brake looseness at servo motor shaft [degrees] (Note 5)		0.19 to 2.5	0.12 to 1.2	0.1 to 0.9	0.3 to 3.5	0.2 to 2.0	0.2 to 1.3	
Brake life (Note 3)	Number of braking cycles [times]	20000	20000	20000	30000	30000	30000	
	Work per braking	[J]	4	15	32	4	18	47
		[oz · in]	567	2126	4535	567	2551	6660

6. CHARACTERISTICS

Item	Servo Motor		HC-SF Series HC-SFS Series		HC-RF Series HC-RFS Series		HC-KF Series HC-KFS Series			HC-AQ Series
	81B 52B to 152B 53B to 153B 524B to 1524B (Note 7)	121B to 301B 202B to 702B 203B • 353B 2024B to 7024B (Note 7)	103B to 203B	353B • 503B	053B 13B	23B • 43B	(Note 6) 73B	0135B to 0335B		
Type (Note 1)	Spring-loaded safety brake									
Rated voltage (Note 4)	24V ⁰ _{-10%} DC									
Power consumption [W]20°C (68°F)	19	34	19	23	6.3	7.9	9	4.8		
Brake static friction torque	[N • m]	8.3	43.1	6.8	16.7	0.32	1.3	2.4	0.098	
	[oz • in]	1176	6103	964	2367	45	6108	340	13.878	
Release delay time (Note 2)	[s]	0.04	0.1	0.03	0.04	0.03	0.1	0.03	0.02	
Braking delay time [s] (Note 2)	DC off	0.03	0.03	0.03	0.03	0.01	0.02	0.03	0.01	
Permissible braking work	Per braking	[J]	400	4500	400	400	5.6	22.0	64.0	4.6
		[oz • in]	56683.3	637687.1	56683.3	56683.3	793.6	3117.6	9069.3	63.882
	Per hour	[J]	4000	45000	4000	4000	56	220	640	46
	[oz • in]	566833	6376871	566833	566833	7936	31176	90693	638.821	
Brake looseness at servo motor shaft (Note 5)	[degrees]	0.2 to 0.6	0.2 to 0.6	0.2 to 0.6	0.2 to 0.6	0.19 to 2.5	0.12 to 1.2	0.1 to 0.9	0.1 to 2.5	
Brake life (Note 3)	Number of braking cycles [times]		20000	20000	20000	20000	20000	20000	20000	20000
		Work per braking	[J]	200	1000	200	200	4	15	32
	[oz • in]	28342	141708	28342	28342	567	2124.18	4535	141.612	

Item	Servo Motor		HC-UF Series HC-UFS Series				HC-LFS Series		
	13B	23B • 43B	73B	72B • 152B	202B to 502B	52B to 152B	202B • 302B		
Type (Note 1)	Spring-loaded safety brake								
Rated voltage (Note 4)	24V ⁰ _{-10%} DC								
Power consumption [W]20°C (68°F)	6.3	7.9	10	19	34	19	34		
Brake static friction torque	[N • m]	0.32	1.3	2.4	8.3	43.1	8.3	43.1	
	[oz • in]	45	184	340	1175	6103	1175	6103	
Release delay time (Note 2)	[s]	0.03	0.03	0.03	0.04	0.1	0.04	0.1	
Braking delay time [s] (Note 2)	DC off	0.01	0.02	0.03	0.03	0.03	0.03	0.03	
Permissible braking work	Per braking	[J]	5.6	22	64	400	4500	400	4500
		[oz • in]	793.6	3117.6	9069.3	56683.3	637687.1	56683.3	637687.1
	Per hour	[J]	56	220	640	4000	45000	4000	45000
	[oz • in]	7936	31176	90693	566833	6376871	566833	6376871	
Brake looseness at servo motor shaft (Note 5)	[degrees]	0.19 to 2.5	0.12 to 1.2	0.1 to 0.9	0.2 to 0.6	0.2 to 0.6	0.2 to 0.6	0.2 to 0.6	
Brake life (Note 3)	Number of braking cycles [times]		20000	20000	20000	20000	20000	20000	
		Work per braking	[J]	4	15	32	200	1000	200
	[oz • in]	567	2126	4535	28342	141708	28342	141708	

6. CHARACTERISTICS

Servo Motor		HA-LFS Series (200/400VAC-compatible)									
		601B 6014B	801B 8014B	12K1B 12K14B	701MB 701M4B	11K1MB 11K1M4B	15K1MB 15K1M4B	11K2B 11K24B	15K2B 15K24B	22K2B 22K24B	
Item											
Type (Note 1)		Spring-loaded safety brake									
Rated voltage (Note 4)		24V ⁰ _{-10%} DC									
Power consumption [W]20°C (68°F)		30	46	46	30	46	46	30	46	46	
Brake static friction torque	[N · m]	82	160.5	160.5	82	160.5	160.5	82	160.5	160.5	
	[oz · in]	11612	22729	22729	11612	22729	22729	11612	22729	22729	
Release delay time (Note 2) [s]		0.25	0.30	0.30	0.25	0.30	0.30	0.25	0.30	0.30	
Braking delay time [s] (Note 2)		DC off									
Permissible braking work	Per braking	[J]	3000	5000	5000	3000	5000	5000	3000	5000	5000
		[oz · in]	424837	708061	708061	424837	708061	708061	424837	708061	708061
	Per hour	[J]	30000	50000	50000	30000	50000	50000	30000	50000	50000
		[oz · in]	4248369	7080614	7080614	4248369	7080614	7080614	4248369	7080614	7080614
Brake looseness at servo motor shaft [degrees] (Note 5)		to 0.8	to 0.8	to 0.8	to 0.8	to 0.8	to 0.8	to 0.8	to 0.8	to 0.8	
Brake life (Note 3)	Number of braking cycles [times]		20000	20000	20000	20000	20000	20000	20000	20000	
	Work per braking	[J]	1000	3000	3000	1000	3000	3000	1000	3000	3000
		[oz · in]	141612	424837	424837	1416212	424837	424837	141612	424837	424837

Note 1. There is no manual release mechanism. When it is necessary to hand-turn the servo motor shaft for machine centering, etc., use a separate 24VDC power supply to release the brake electrically.

2. The value for initial ON gap at 20°C (68°F).

3. The brake gap will increase as the brake lining wears, but the gap is not adjustable. The brake life indicated is the number of braking cycles after which adjustment will be required.

4. 24VDC of the internal power output for interface (VDD) cannot be used. Always use a separate power supply.

5. The above values are typical initial values and not guaranteed values.

6. 73B is not available for the HC-KF.

7. 524B to 7024B are not available for the HC-SF.

(1) Sound generation

Though the brake lining may rattle during operation, it poses no functional problem.

If braking sound occurs, it may be improved by setting the machine resonance suppression filter or adaptive vibration suppression control in the servo amplifier parameters. For details, refer to the servo amplifier instruction manual.

6. CHARACTERISTICS

(2) Electromagnetic brake power supply

24VDC of the internal power output for interface (VDD) cannot be used. Prepare the following power supply for use with the electromagnetic brake only.

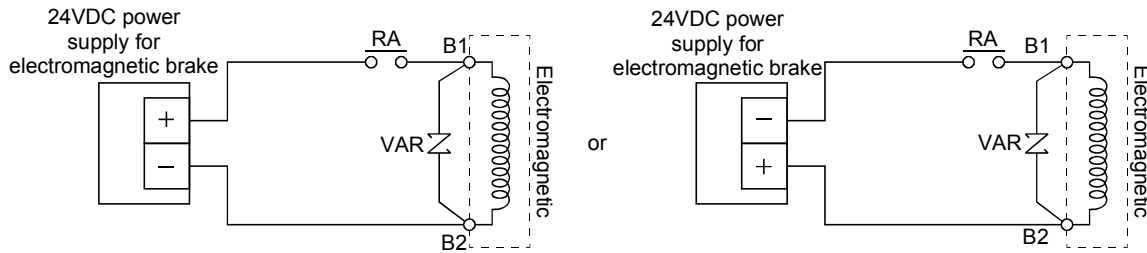

The surge absorber (VAR) must be installed across B1-B2. For the selection of the surge absorber, refer to OPTIONS AND AUXILIARY EQUIPMENT of the Servo Amplifier Instruction Manual. The electromagnetic brake terminals (B1, B2) have no polarity.

(3) Coasting distance

At an emergency stop, the servo motor will decelerate to a stop in the pattern shown in the following diagram. Here, the maximum coasting distance (during fast feed), L_{max} , will be the area shown with the diagonal line in the figure and can be calculated approximately with Equation 6.1. The effect of the load torque is greater near the stopping area. When the load torque is large, the servo motor will stop faster than the value obtained in the equation.

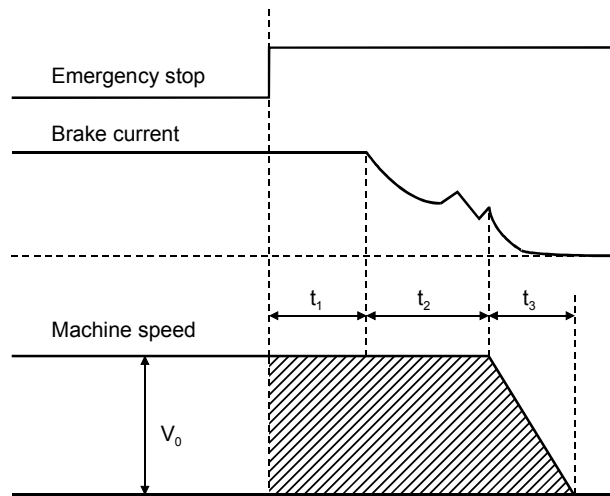

(4) Others

A leakage magnetic flux will occur at the shaft end of the servo motor equipped with electromagnetic brake. Note that chips, screws and other magnetic substances are attracted.

6. CHARACTERISTICS

$$L_{\max} = \frac{V_0}{60} \cdot \left(t_1 + t_2 + \frac{t_3}{2} \right) \dots\dots\dots (6.1)$$

Where,

- L max : Maximum coasting distance [mm]
- V₀: Machine's fast feed speed [mm/min]
- t₁: Delay time of control section [s]
- t₂: Braking delay time of brake (Note) [s]
- t₃: Braking time [s]

$$t_3 = \frac{(J_L + J_M) \cdot N_0}{9.55 \times 10^4 \cdot (T_L + 0.8T_B)}$$

- J_L : Load inertia moment converted into equivalent value on servo motor shaft [kg · cm²]
- J_M : Servo motor inertia moment [kg · cm²]
- N₀ : Servo motor speed during fast feed [r/min]
- T_L : Load torque converted into equivalent value on servo motor shaft [N · m]
- T_B : Brake static friction torque (Note) [N · m]

Note. t₂ and T_B are the values noted in Table 6.1 Characteristics. J_L is the machine's inertia moment at the servo motor shaft.

6.2 Vibration rank

The vibration rank of the servo motor is V-10 at the rated speed. Measure vibration in the following position with the servo motor installed as shown below.

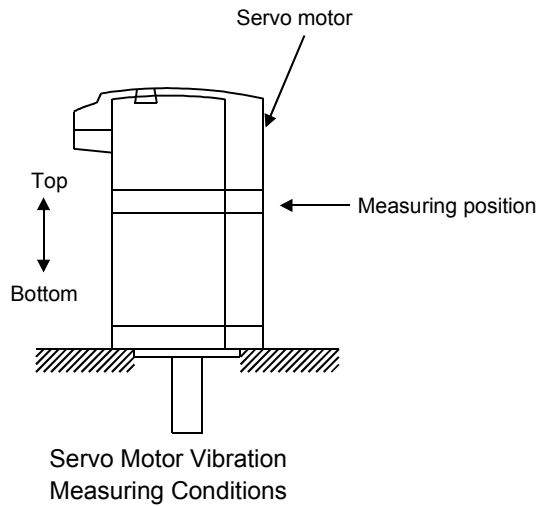

6. CHARACTERISTICS

6.3 Machine accuracies

The following table indicates the machine accuracies of the servo motor around the output shaft and mounting. (except the optional products)

Accuracy [mm]	Measuring Position	Flange Size			
		Less than □100	□100 • □130	□176 to □250	□280 or more
Runout of flange surface to output shaft	a)	0.05	0.06	0.08	0.08
Runout of fitting OD of flange surface	b)	0.04	0.04	0.06	0.08
Runout of output shaft end	c)	0.02	0.02	0.03	0.03

Reference diagram

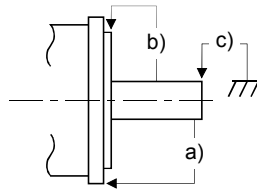

7. OUTLINE DIMENSION DRAWINGS

7. OUTLINE DIMENSION DRAWINGS

7.1 Servo motors

7.1.1 HC-MF • HC-KF series

(1) Standard (without electromagnetic brake, without reduction gear)

Model	Output [W]	Variable Dimensions		Inertia Moment $J[\times 10^{-4} \text{ kg} \cdot \text{m}^2]$	Mass [kg]
		L	KL		
HC-MF053	50	81.5	29.5	0.019	0.40
HC-MF13	100	96.5	44.5	0.03	0.53
HC-KF053	50	81.5	29.5	0.053	0.40
HC-KF13	100	96.5	44.5	0.084	0.53

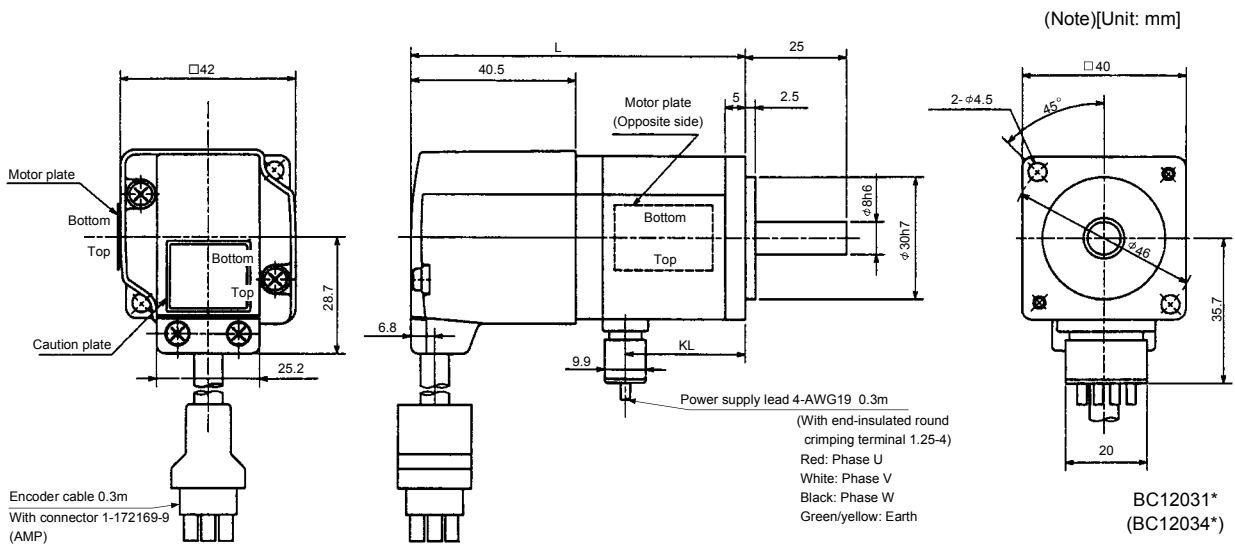

Note: The dimensions without tolerances are reference dimensions.

Model	Output [W]	Variable Dimensions		Inertia Moment $J[\times 10^{-4} \text{ kg} \cdot \text{m}^2]$	Mass [kg]
		L	KL		
HC-MF23	200	99.5	49.1	0.088	0.99
HC-MF43	400	124.5	72.1	0.143	1.45
HC-KF23	200	99.5	49.1	0.260	0.99
HC-KF43	400	124.5	72.1	0.460	1.45

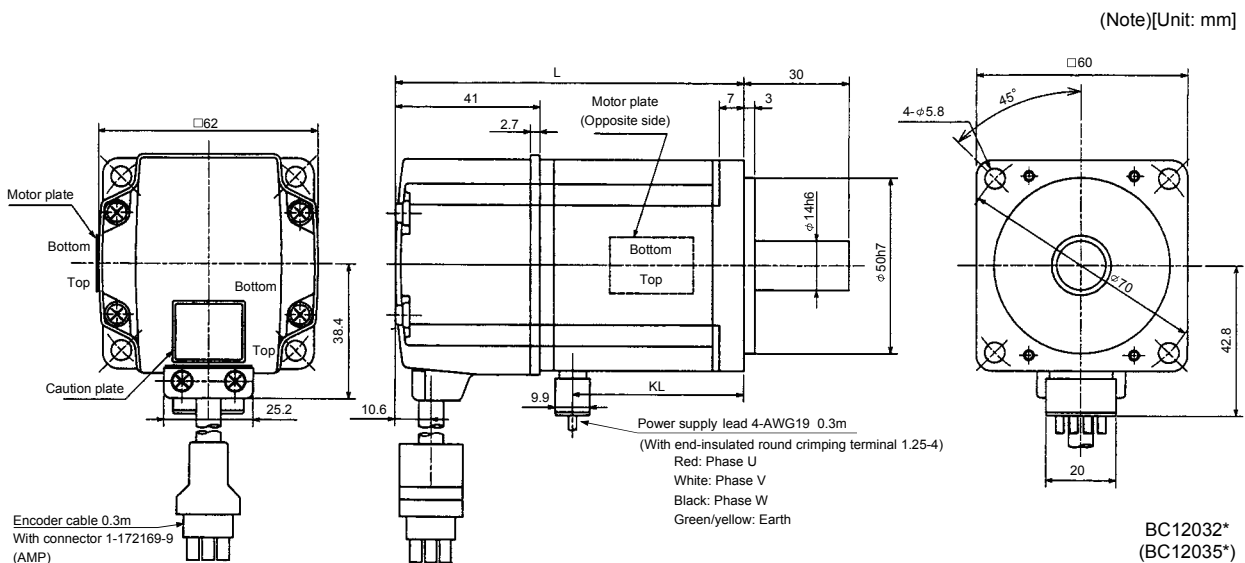

Note: The dimensions without tolerances are reference dimensions.

7. OUTLINE DIMENSION DRAWINGS

Model	Output [W]	Inertia Moment $J[\times 10^{-4} \text{kg} \cdot \text{m}^2]$	Mass [kg]
HC-MF73	750	0.6	3

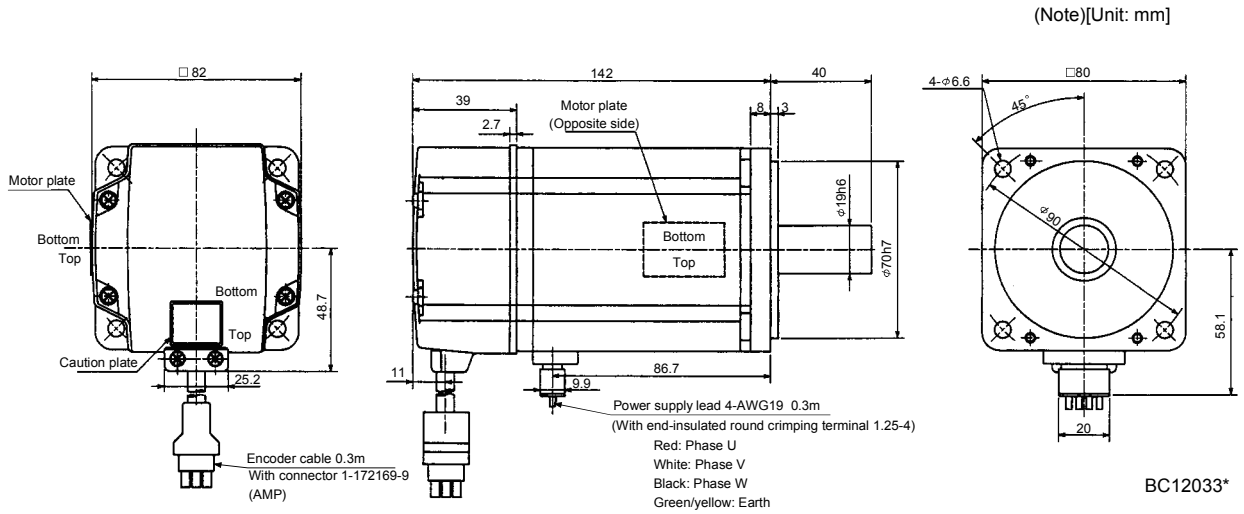

Note: The dimensions without tolerances are reference dimensions.

(2) With electromagnetic brake

Model	Output [W]	Variable Dimensions		Brake static friction torque [N · m]	Inertia Moment $J[\times 10^{-4} \text{kg} \cdot \text{m}^2]$	Mass [kg]
		L	KL			
HC-MF053B	50	109.5	29.5	0.32	0.022	0.75
HC-MF13B	100	124.5	44.5	0.32	0.032	0.89
HC-KF053B	50	109.5	29.5	0.32	0.056	0.75
HC-KF13B	100	124.5	44.5	0.32	0.087	0.89

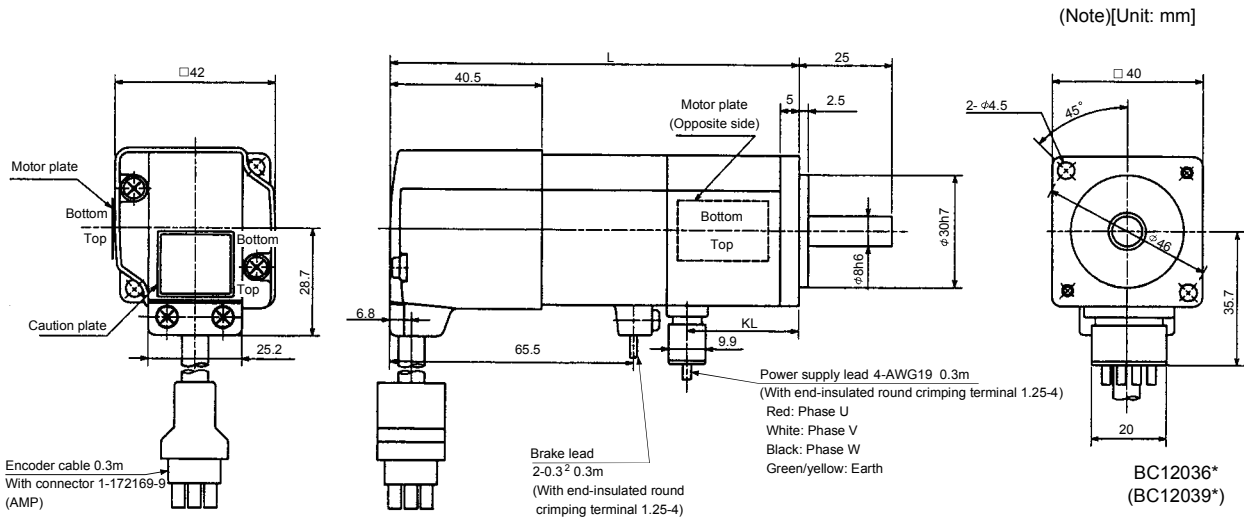

Note: The dimensions without tolerances are reference dimensions.

7. OUTLINE DIMENSION DRAWINGS

Model	Output [W]	Variable Dimensions		Brake static friction torque [N · m]	Inertia Moment $J[\times 10^{-4} \text{kg} \cdot \text{m}^2]$	Mass [kg]
		L	KL			
HC-MF23B	200	131.5	49.1	1.3	0.136	1.6
HC-MF43B	400	156.5	72.1	1.3	0.191	2.1
HC-KF23B	200	131.5	49.1	1.3	0.310	1.6
HC-KF43B	400	156.5	72.1	1.3	0.510	2.1

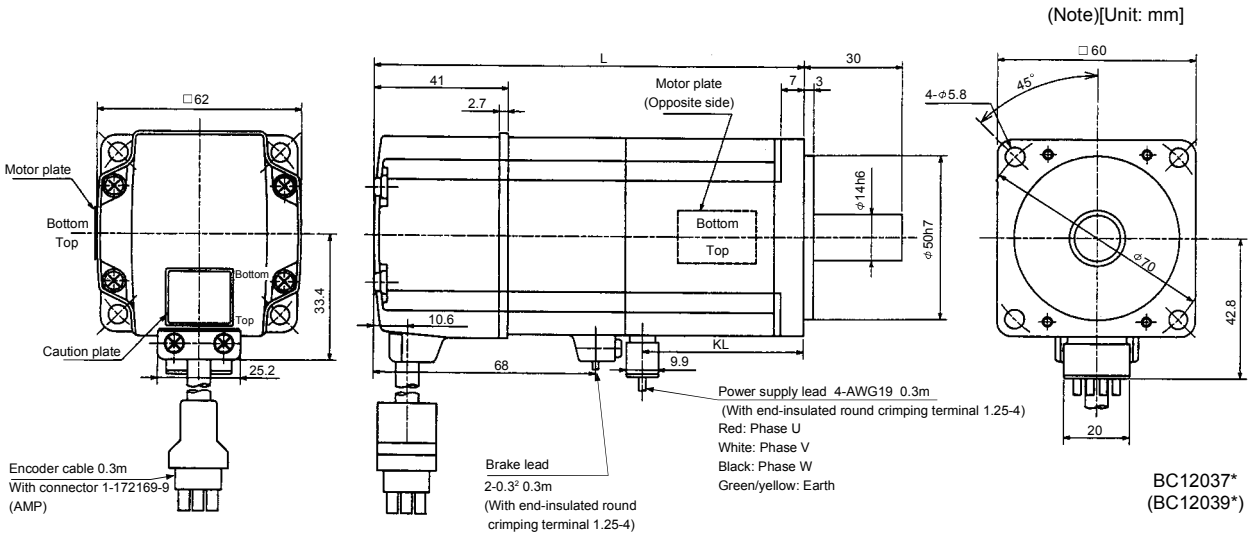

Note: The dimensions without tolerances are reference dimensions.

Model	Output [W]	Brake static friction torque [N · m]	Inertia Moment $J[\times 10^{-4} \text{kg} \cdot \text{m}^2]$	Mass [kg]
HC-MF73B	750	2.4	0.725	4.0

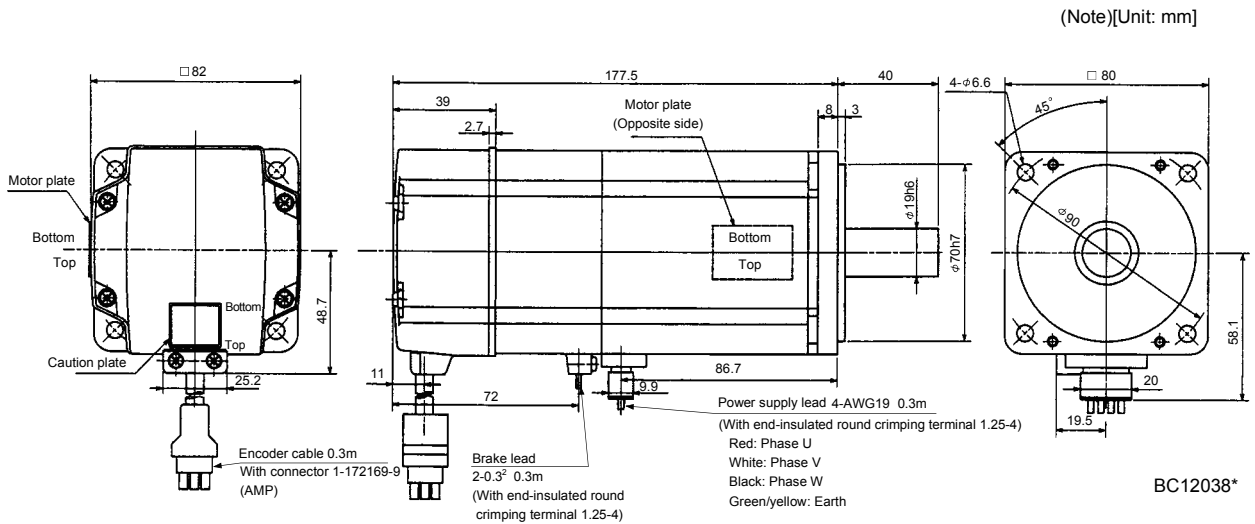

Note: The dimensions without tolerances are reference dimensions.

7. OUTLINE DIMENSION DRAWINGS

(3) With reduction gear for general industrial machine

The outer frame of the reduction gear is a material surface such as casting. Its actual dimensions may be 1 to 3mm larger than the drawing dimensions. Design the machine side with allowances.

(a) Without electromagnetic brake

Model	Output [W]	Variable Dimensions		Reduction Gear Model	Reduction Ratio (Actual Reduction Ratio)	Inertia Moment $J[\times 10^{-4} \text{kg} \cdot \text{m}^2]$	Backlash	Mass [kg]
		L	KL					
HC-MF053G1	50	126	74	K6505	1/5(9/44)	0.055	60min. max.	1.4
HC-MF053G1	50	144	92	K6512	1/12(49/576)	0.077	60min. max.	1.8
HC-MF053G1	50	144	92	K6520	1/20(25/484)	0.059	60min. max.	1.8
HC-KF053G1	50	126	74	K6505	1/5(9/44)	0.090	60min. max.	1.4
HC-KF053G1	50	144	92	K6512	1/12(49/576)	0.112	60min. max.	1.8
HC-KF053G1	50	144	92	K6520	1/20(25/484)	0.094	60min. max.	1.8

(Note)[Unit: mm]

For reverse rotation command
"Rotation direction"
For forward rotation command

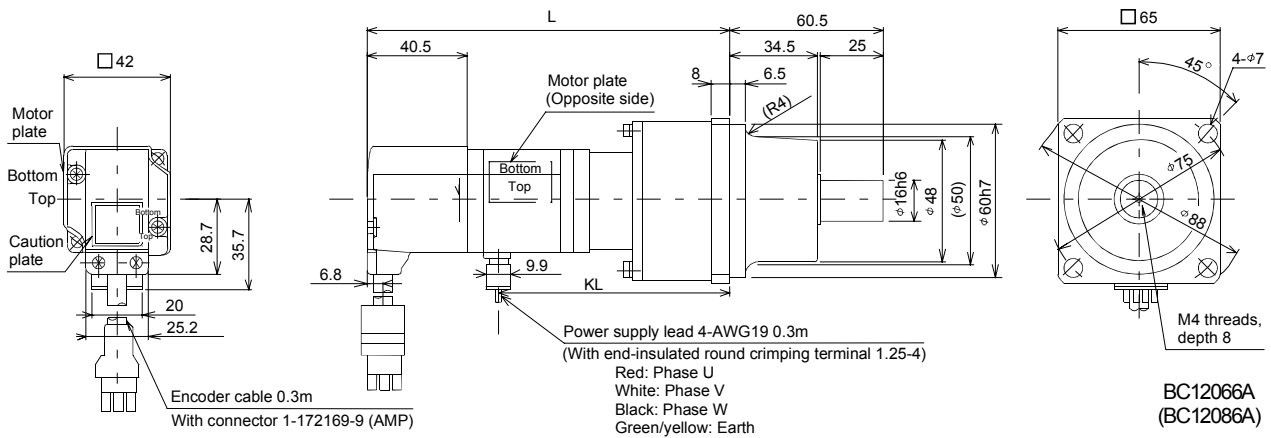

BC12066A
(BC12086A)

Note: The dimensions without tolerances are reference dimensions.

Model	Output [W]	Variable Dimensions		Reduction Gear Model	Reduction Ratio (Actual Reduction Ratio)	Inertia Moment $J[\times 10^{-4} \text{kg} \cdot \text{m}^2]$	Backlash	Mass [kg]
		L	KL					
HC-MF13G1	100	141	89	K6505	1/5(9/44)	0.067	60min. max.	1.5
HC-MF13G1	100	159	107	K6512	1/12(49/576)	0.089	60min. max.	1.9
HC-MF13G1	100	159	107	K6520	1/20(25/484)	0.071	60min. max.	1.9
HC-KF13G1	100	141	89	K6505	1/5(9/44)	0.121	60min. max.	1.5
HC-KF13G1	100	159	107	K6512	1/12(49/576)	0.143	60min. max.	1.9
HC-KF13G1	100	159	107	K6520	1/20(25/484)	0.125	60min. max.	1.9

(Note)[Unit: mm]

For reverse rotation command
"Rotation direction"
For forward rotation command

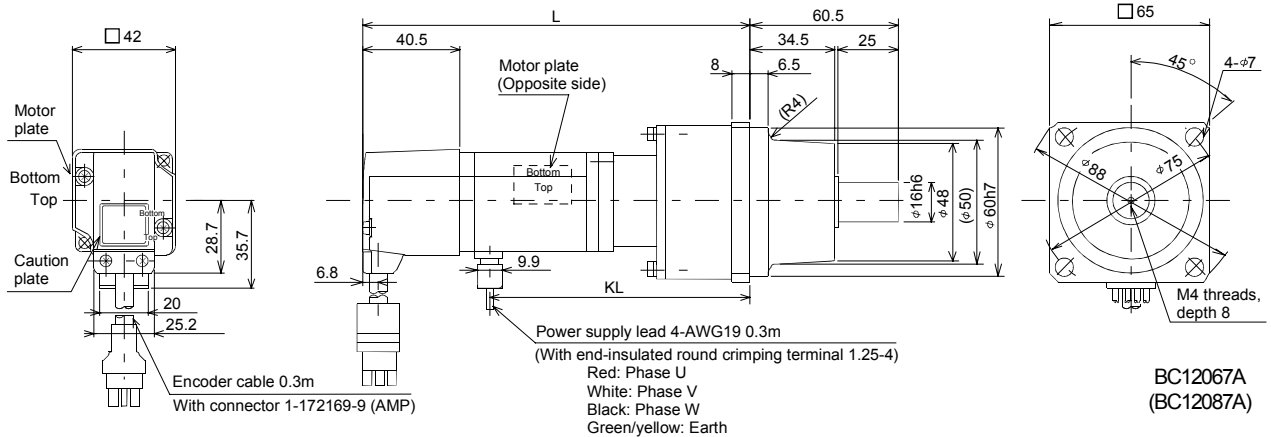

BC12067A
(BC12087A)

Note: The dimensions without tolerances are reference dimensions.

7. OUTLINE DIMENSION DRAWINGS

Model	Output [W]	Variable Dimensions		Reduction Gear Model	Reduction Ratio (Actual Reduction Ratio)	Inertia Moment $J[\times 10^{-4} \text{kg} \cdot \text{m}^2]$	Mass [kg]
		L	KL				
HC-MF23G1	200	153	102.6	K9005	1/5(19/96)	0.249	3.3
HC-MF23G1	200	173	122.6	K9012	1/12(25/288)	0.293	3.9
HC-MF23G1	200	173	122.6	K9020	1/20(253/5000)	0.266	3.9
HC-KF23G1	200	153	102.6	K9005	1/5(19/96)	0.420	3.3
HC-KF23G1	200	173	122.6	K9012	1/12(25/288)	0.470	3.9
HC-KF23G1	200	173	122.6	K9020	1/20(253/5000)	0.440	3.9

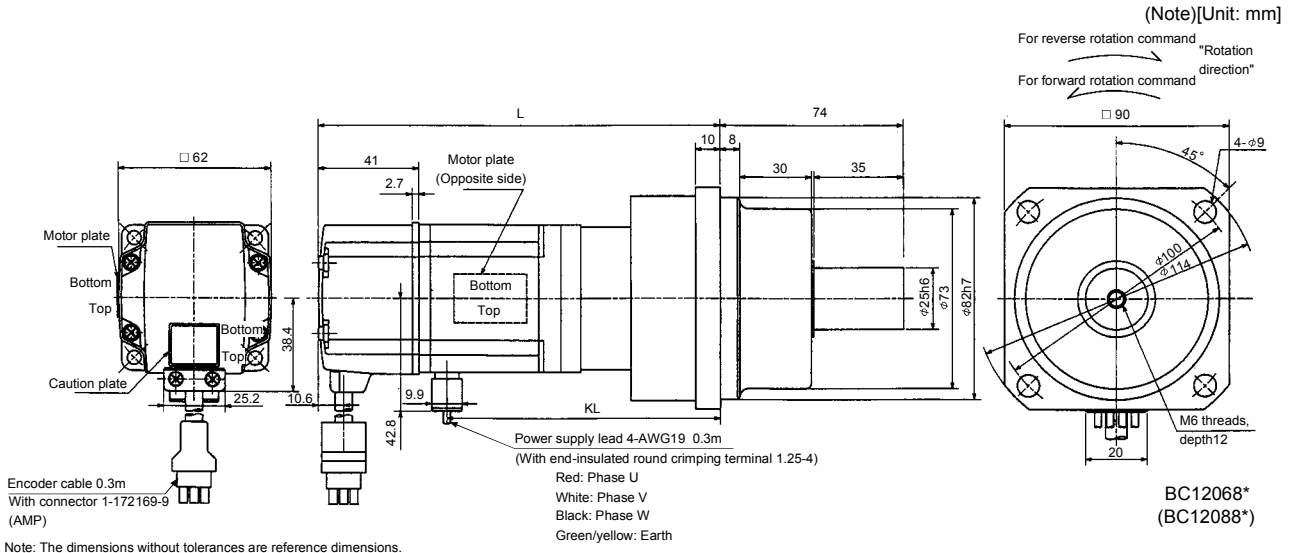

Model	Output [W]	Variable Dimensions		Reduction Gear Model	Reduction Ratio (Actual Reduction Ratio)	Inertia Moment $J[\times 10^{-4} \text{kg} \cdot \text{m}^2]$	Mass [kg]
		L	KL				
HC-MF43G1	400	178	125.6	K9005	1/5(19/96)	0.296	3.8
HC-MF43G1	400	198	145.6	K9012	1/12(25/288)	0.339	4.4
HC-KF43G1	400	178	125.6	K9005	1/5(19/96)	0.610	3.8
HC-KF43G1	400	198	145.6	K9012	1/12(25/288)	0.660	4.4

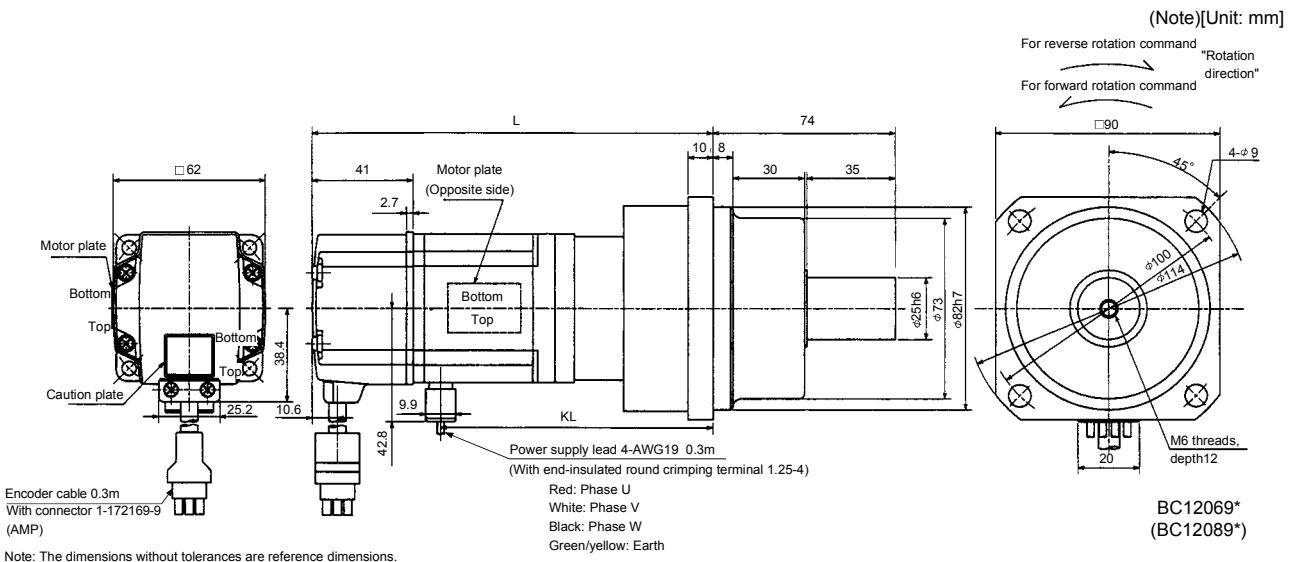

7. OUTLINE DIMENSION DRAWINGS

Model	Output [W]	Reduction Gear Model	Reduction Ratio		Inertia Moment $J[\times 10^{-4} \text{kg} \cdot \text{m}^2]$	Backlash	Mass [kg]
			Normal Reduction ratio	Actual Reduction Ratio			
HC-MF43G1	400	K10020	1/20	253/5000	0.653	60min. max.	5.5
HC-MF73G1	750	K10005	1/5	1/5	1.02	60min. max.	6.2
HC-MF73G1	750	K10012	1/12	525/6048	1.686	60min. max.	7.3
HC-MF73G1	750	K12020	1/20	625/12544	1.75	60min. max.	10.1

Model	Output [W]	Variable Dimensions																						
		D	LH	LK	LT	H	LA	LB	LC	LD	LE	LF	LG	LM	LN	LP	L	LR	KL	LZ	Q	S	P	R
HC-MF43G1	400	62	38.4	41	10.6	42.8	115	95	132	100	10	73	10	13	16	86	201.5	90	149.1	9	50	32	M8	16
HC-MF73G1	750	82	48.7	39	11	58.1	115	95	132	100	10	73	10	13	16	86	207	90	151.7	9	50	32	M8	16
HC-MF73G1	750	82	48.7	39	11	58.1	115	95	132	100	10	73	10	13	16	86	229	90	173.7	9	50	32	M8	16
HC-MF73G1	750	82	48.7	39	11	58.1	140	115	162	120	12	90	15	13	20	104	242	106	186.7	14	60	40	M10	20

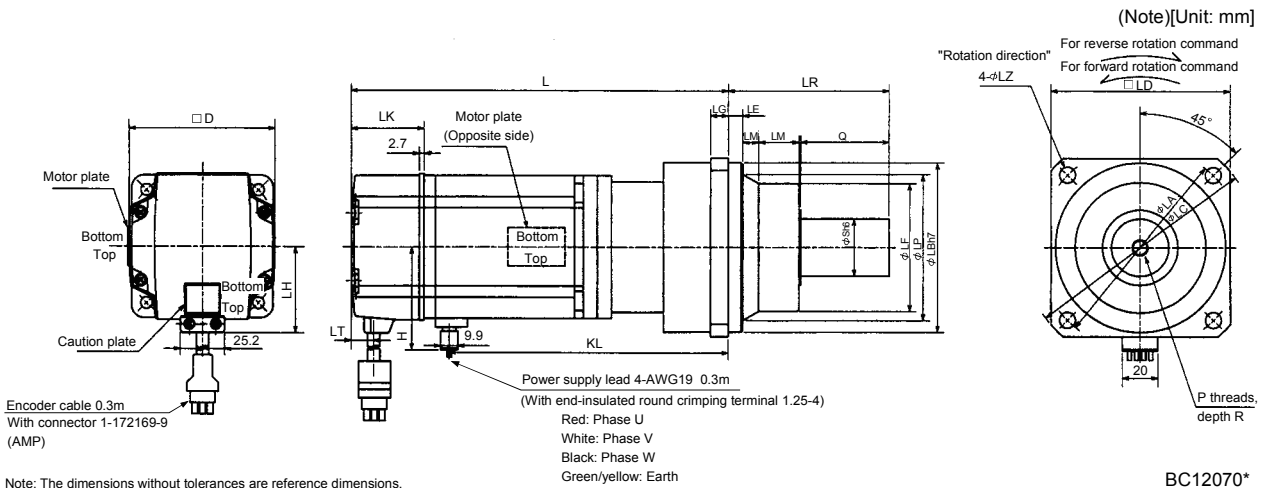

Model	Output [W]	Reduction Gear Model	Reduction Ratio		Inertia Moment $J[\times 10^{-4} \text{kg} \cdot \text{m}^2]$	Backlash	Mass [kg]
			Normal Reduction ratio	Actual Reduction Ratio			
HC-KF43G1	400	K10020	1/20	253/5000	0.970	60min. max.	5.5

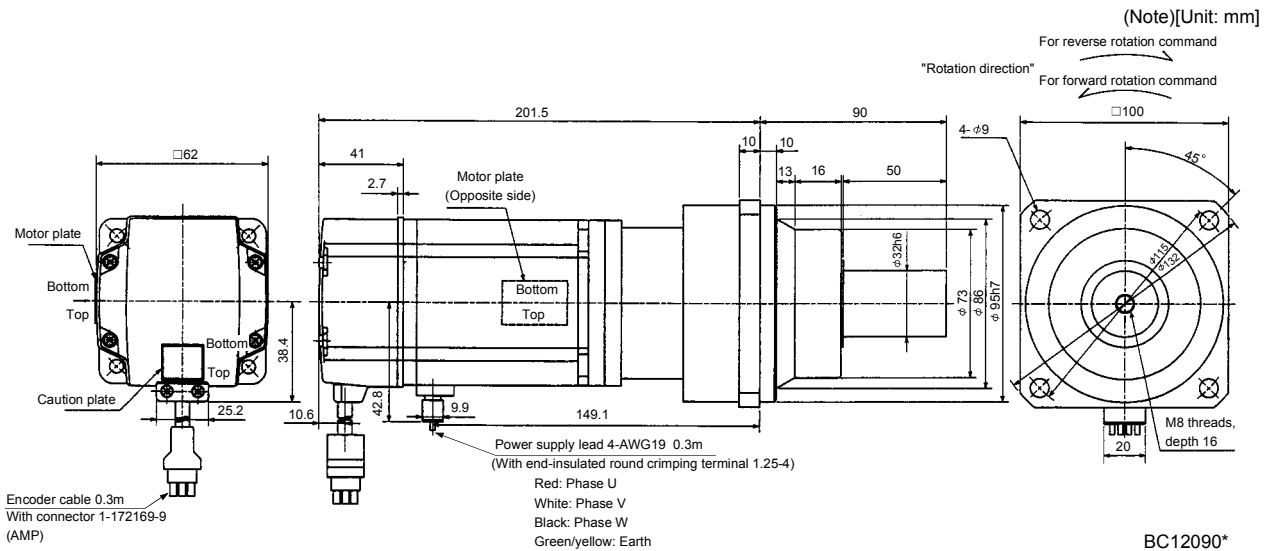

7. OUTLINE DIMENSION DRAWINGS

(b) With electromagnetic brake

Model	Output [W]	Variable Dimensions		Brake static friction torque [N · m]	Reduction Gear Model	Reduction Ratio (Actual Reduction Ratio)	Inertia Moment $J[\times 10^{-4} \text{ kg} \cdot \text{m}^2]$	Backlash	Mass [kg]
		L	KL						
HC-MF053BG1	50	154	74	0.32	K6505	1/5(9/44)	0.058	60min. max.	1.8
HC-MF053BG1	50	172	92	0.32	K6512	1/12(49/576)	0.080	60min. max.	2.2
HC-MF053BG1	50	172	92	0.32	K6520	1/20(25/484)	0.062	60min. max.	2.2
HC-KF053BG1	50	154	74	0.32	K6505	1/5(9/44)	0.093	60min. max.	1.8
HC-KF053BG1	50	172	92	0.32	K6512	1/12(49/576)	0.115	60min. max.	2.2
HC-KF053BG1	50	172	92	0.32	K6520	1/20(25/484)	0.097	60min. max.	2.2

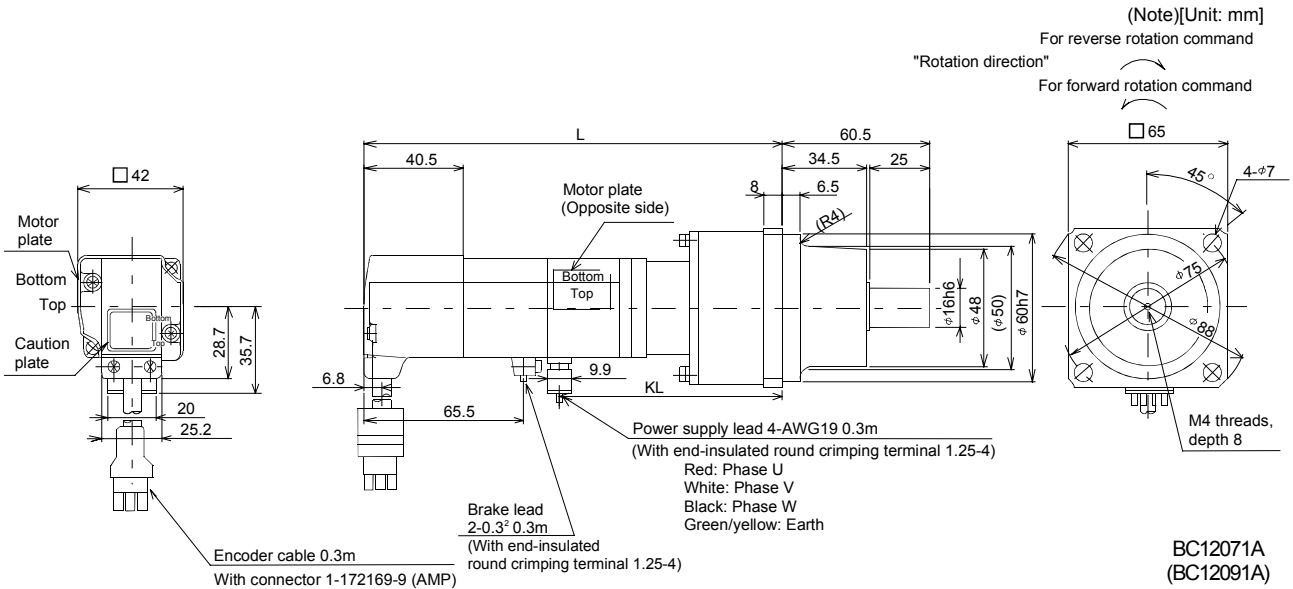

Note: The dimensions without tolerances are reference dimensions.

Model	Output [W]	Variable Dimensions		Brake static friction torque [N · m]	Reduction Gear Model	Reduction Ratio (Actual Reduction Ratio)	Inertia Moment $J[\times 10^{-4} \text{ kg} \cdot \text{m}^2]$	Backlash	Mass [kg]
		L	KL						
HC-MF13BG1	100	169	89	0.32	K6505	1/5(9/44)	0.069	60min. max.	1.9
HC-MF13BG1	100	187	107	0.32	K6512	1/12(49/576)	0.091	60min. max.	2.3
HC-MF13BG1	100	187	107	0.32	K6520	1/20(25/484)	0.073	60min. max.	2.3
HC-KF13BG1	100	169	89	0.32	K6505	1/5(9/44)	0.124	60min. max.	1.9
HC-KF13BG1	100	187	107	0.32	K6512	1/12(49/576)	0.146	60min. max.	2.3
HC-KF13BG1	100	187	107	0.32	K6520	1/20(25/484)	0.128	60min. max.	2.3

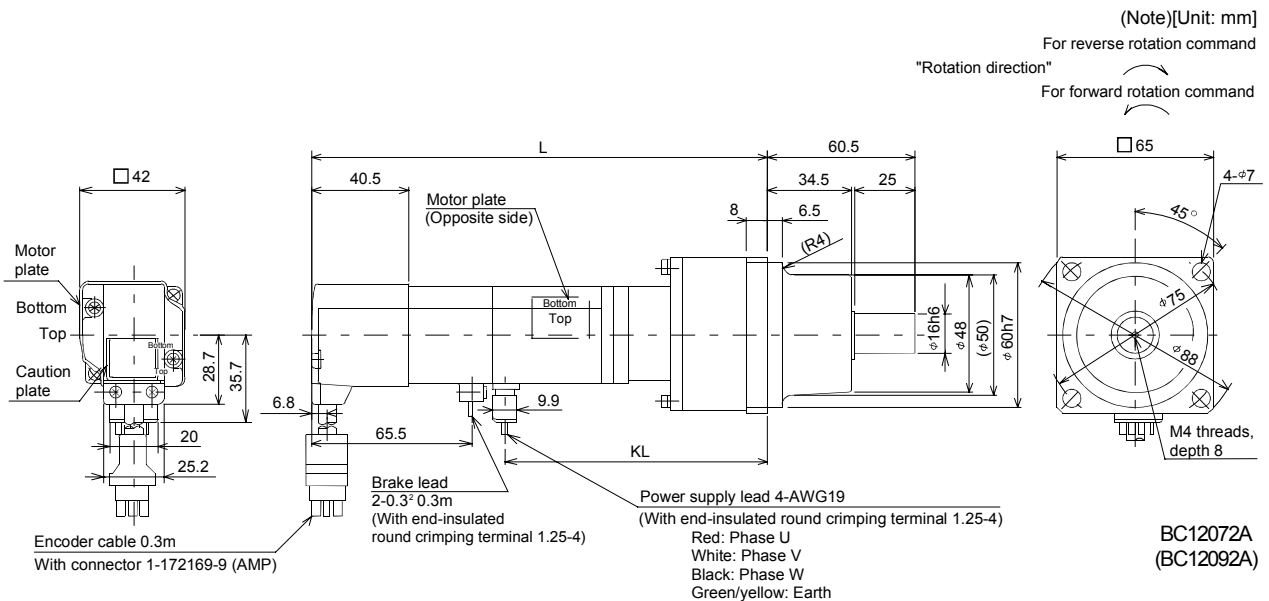

Note: The dimensions without tolerances are reference dimensions.

7. OUTLINE DIMENSION DRAWINGS

Model	Output [W]	Variable Dimensions		Reduction Gear Model	Reduction Ratio (Actual Reduction Ratio)	Inertia Moment $J[\times 10^{-4} \text{kg} \cdot \text{m}^2]$	Mass [kg]	Brake static friction torque [N · m]
		L	KL					
HC-MF23BG1	200	185	102.6	K9005	1/5(19/96)	0.289	3.9	1.3
HC-MF23BG1	200	205	122.6	K9012	1/12(25/288)	0.333	4.5	1.3
HC-MF23BG1	200	205	122.6	K9020	1/20(253/5000)	0.306	4.5	1.3
HC-KF23BG1	200	185	102.6	K9005	1/5(19/96)	0.470	3.9	1.3
HC-KF23BG1	200	205	122.6	K9012	1/12(25/288)	0.520	4.5	1.3
HC-KF23BG1	200	205	122.6	K9020	1/20(253/5000)	0.490	4.5	1.3

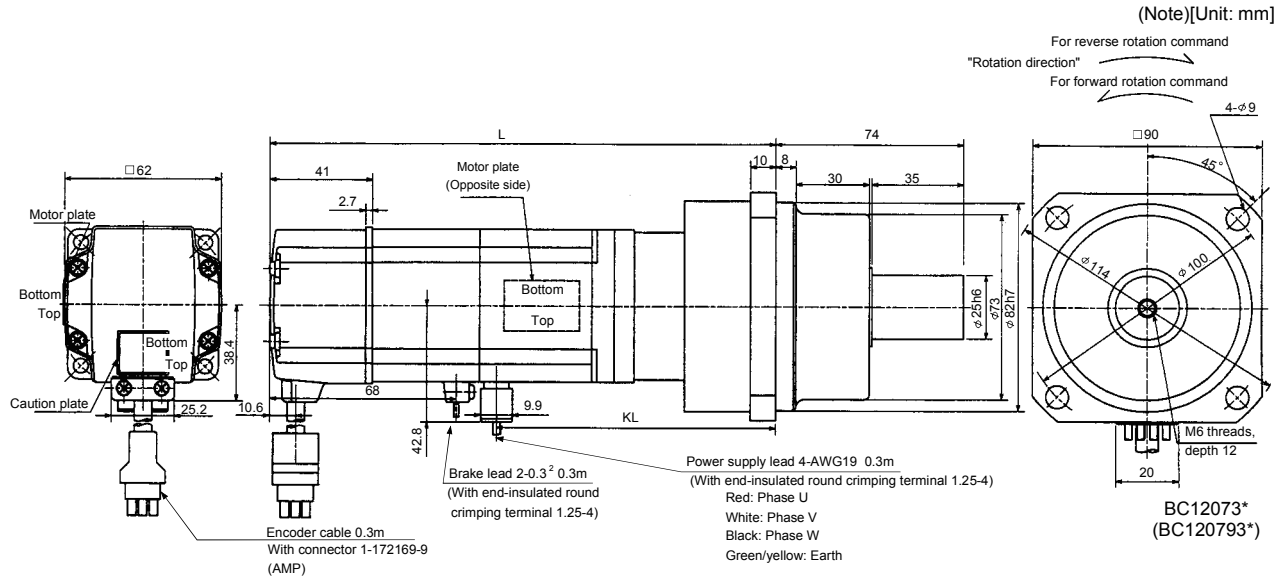

Model	Output [W]	Variable Dimensions		Brake static friction torque [N · m]	Reduction Gear Model	Reduction Ratio (Actual Reduction Ratio)	Inertia Moment $J[\times 10^{-4} \text{kg} \cdot \text{m}^2]$	Mass [kg]
		L	KL					
HC-MF43BG1	400	210	125.6	1.3	K9005	1/5(19/96)	0.344	4.4
HC-MF43BG1	400	230	145.6	1.3	K9012	1/12(25/288)	0.388	5.0
HC-KF43BG1	400	210	125.6	1.3	K9005	1/5(19/96)	0.660	4.4
HC-KF43BG1	400	230	145.6	1.3	K9012	1/12(25/288)	0.710	5.0

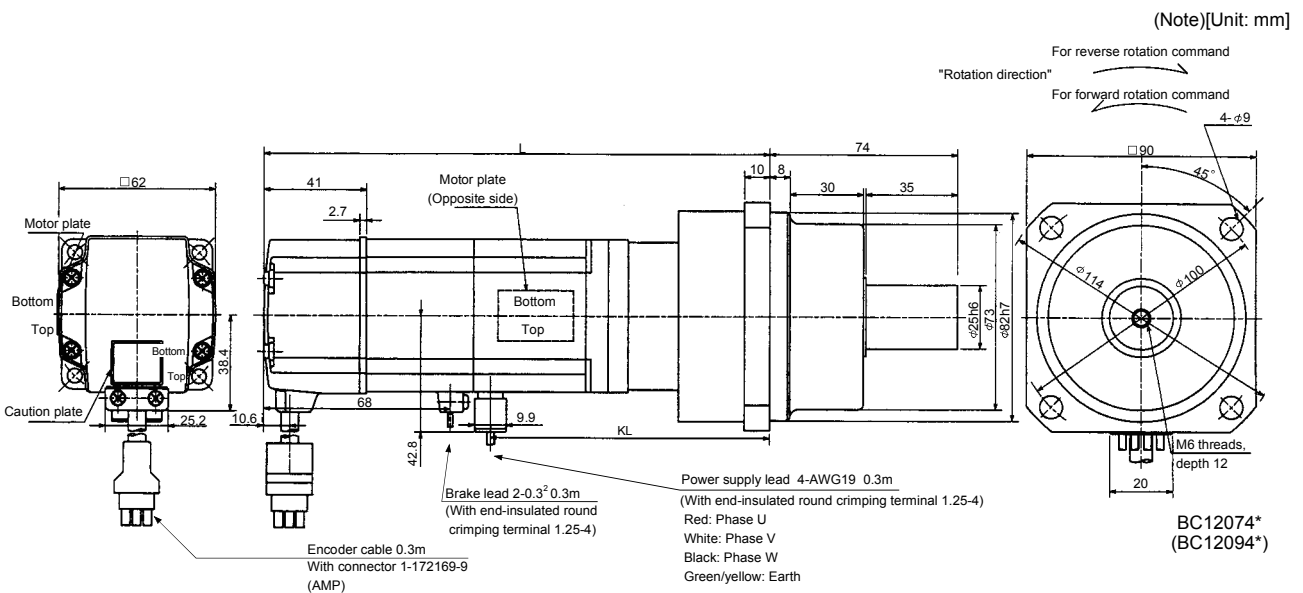

7. OUTLINE DIMENSION DRAWINGS

Model	Output [W]	Brake static friction torque [N · m]	Reduction Gear Model	Reduction Ratio		Inertia Moment J[×10 ⁻⁴ kg · m ²]	Backlash	Mass [kg]
				Normal Reduction ratio	Actual Reduction Ratio			
HC-MF43BG1	400	1.3	K10020	1/20	253/5000	0.700	60min. max.	6.1
HC-MF73BG1	750	2.4	K10005	1/5	1/5	1.145	60min. max.	7.2
HC-MF73BG1	750	2.4	K10012	1/12	525/6048	1.811	60min. max.	8.3
HC-MF73BG1	750	2.4	K12020	1/20	625/12544	1.875	60min. max.	11.1

Model	Output [W]	Variable Dimensions																							
		D	LH	LK	LT	LX	H	LA	LB	LC	LD	LE	LF	LG	LM	LN	LP	L	LR	KL	LZ	Q	S	P	R
HC-MF43BG1	400	62	38.4	41	10.6	68	42.8	115	95	132	100	10	73	10	13	16	86	233.5	90	149.1	9	50	32	M8	16
HC-MF73BG1	750	82	48.7	39	11	72	58.1	115	95	132	100	10	73	10	13	16	86	242.5	90	151.7	9	50	32	M8	16
HC-MF73BG1	750	82	48.7	39	11	72	58.1	115	95	132	100	10	73	10	13	16	86	264.5	90	173.7	9	50	32	M8	16
HC-MF73BG1	750	82	48.7	39	11	72	58.1	140	115	162	120	12	90	15	13	20	104	277.5	106	186.7	14	60	40	M10	20

(Note)[Unit: mm]

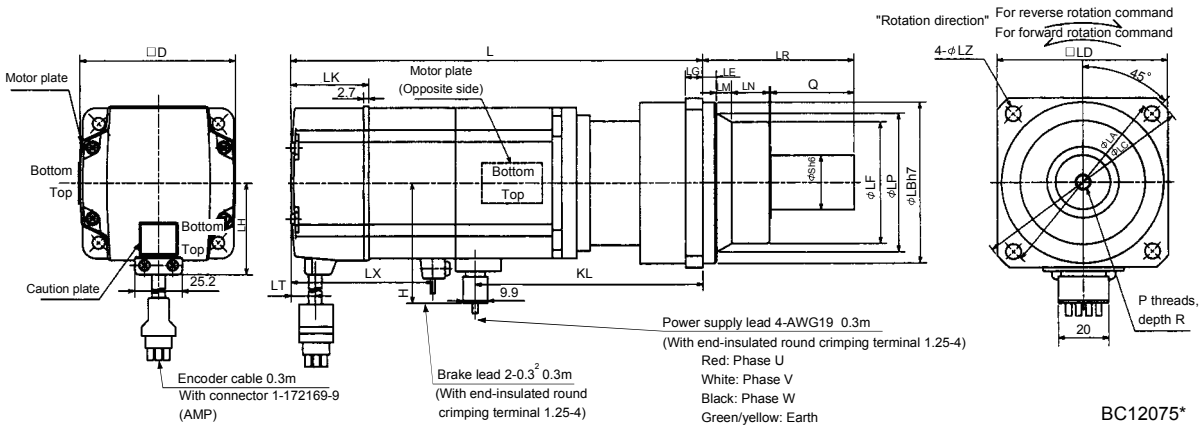

BC12075*

Note: The dimensions without tolerances are reference dimensions.

Model	Output [W]	Brake static friction torque [N · m]	Reduction Gear Model	Reduction Ratio		Inertia Moment J[×10 ⁻⁴ kg · m ²]	Backlash	Mass [kg]
				Normal Reduction ratio	Actual Reduction Ratio			
HC-KF43BG1	400	1.3	K10020	1/20	253/5000	1.02	60min. max.	6.1

(Note)[Unit: mm]

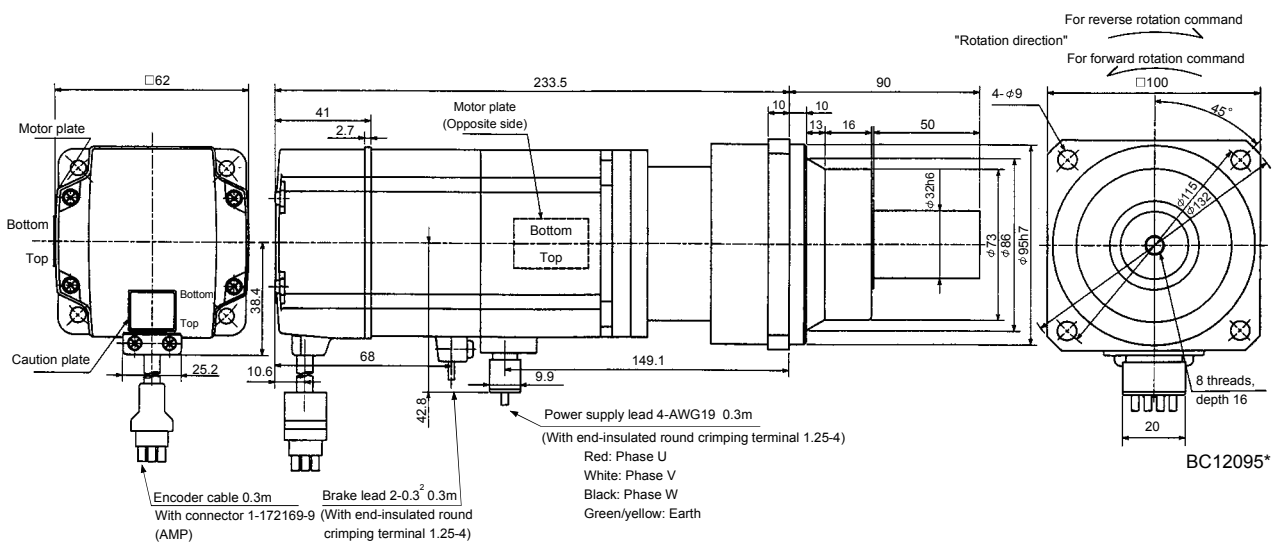

BC12095*

Note: The dimensions without tolerances are reference dimensions.

7. OUTLINE DIMENSION DRAWINGS

(4) With reduction gear for precision application

The outer frame of the reduction gear is a material surface such as casting. Its actual dimensions may be 1 to 3mm larger than the drawing dimensions. Design the machine side with allowances.

(a) Without electromagnetic brake

Model	Output [W]	Variable Dimensions		Reduction Gear Model	Reduction Ratio	Inertia Moment $J[\times 10^{-4} \text{kg} \cdot \text{m}^2]$	Backlash	Mass [kg]
		L	KL					
HC-MF053G2	50	130	78	BK1-05B-A5MEKA	1/5	0.067	3 min. max.	1.4
HC-MF053G2	50	146	94	BK1-09B-A5MEKA	1/9	0.060	3 min. max.	1.7
HC-MF053G2	50	146	94	BK1-20B-A5MEKA	1/20	0.069	3 min. max.	1.8
HC-MF053G2	50	146	94	BK1-29B-A5MEKA	1/29	0.057	3 min. max.	1.8
HC-KF053G2	50	130	78	BK1-05B-A5MEKA	1/5	0.101	3 min. max.	1.4
HC-KF053G2	50	146	94	BK1-09B-A5MEKA	1/9	0.095	3 min. max.	1.7
HC-KF053G2	50	146	94	BK1-20B-A5MEKA	1/20	0.104	3 min. max.	1.8
HC-KF053G2	50	146	94	BK1-29B-A5MEKA	1/29	0.092	3 min. max.	1.8

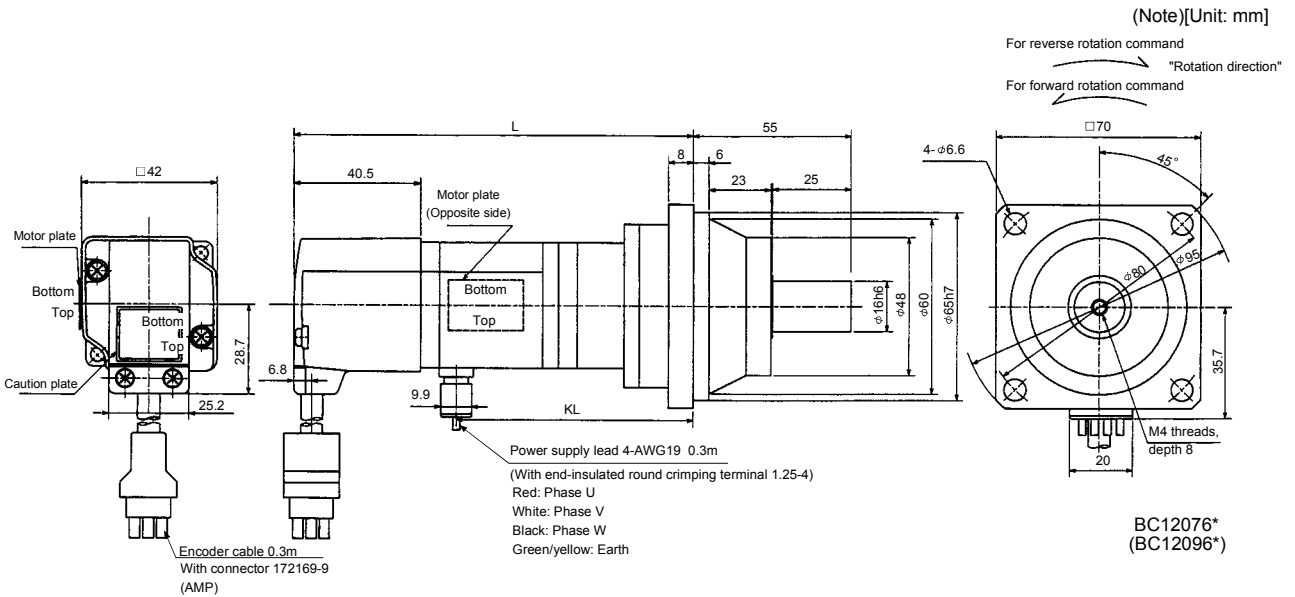

Note: The dimensions without tolerances are reference dimensions.

7. OUTLINE DIMENSION DRAWINGS

Model	Output [W]	Reduction Gear Model	Reduction Ratio	Inertia Moment $J[\times 10^{-4} \text{kg} \cdot \text{m}^2]$	Backlash	Mass [kg]
HC-MF13G2	100	BK1-05B-01MEKA	1/5	0.078	3 min. max.	1.5
HC-MF13G2	100	BK1-09B-01MEKA	1/9	0.072	3 min. max.	1.8
HC-MF13G2	100	BK2-20B-01MEKA	1/20	0.122	3 min. max.	3.0
HC-MF13G2	100	BK2-29B-01MEKA	1/29	0.096	3 min. max.	3.0

Model	Output [W]	Variable Dimensions																
		LA	LB	LC	LD	LE	LF	LG	LH	LK	L	LR	KL	LZ	Q	S	P	R
HC-MF13G2	100	80	65	95	70	6	48	8	60	23	145	55	93	6.6	25	16	M4	8
HC-MF13G2	100	80	65	95	70	6	48	8	60	23	161	55	109	6.6	25	16	M4	8
HC-MF13G2	100	100	80	115	85	6	65	10	74	33	167	75	115	6.6	35	20	M5	10
HC-MF13G2	100	100	80	115	85	6	65	10	74	33	167	75	115	6.6	35	20	M5	10

Model	Output [W]	Reduction Gear Model	Reduction Ratio	Inertia Moment $J[\times 10^{-4} \text{kg} \cdot \text{m}^2]$	Backlash	Mass [kg]
HC-KF13G2	100	BK1-05B-01MEKA	1/5	0.132	3 min. max.	1.5
HC-KF13G2	100	BK1-09B-01MEKA	1/9	0.126	3 min. max.	1.8
HC-KF13G2	100	BK2-20B-01MEKA	1/20	0.176	3 min. max.	3.0
HC-KF13G2	100	BK2-29B-01MEKA	1/29	0.150	3 min. max.	3.0

Model	Output [W]	Variable Dimensions																
		LA	LB	LC	LD	LE	LF	LG	LH	LK	L	LR	KL	LZ	Q	S	P	R
HC-KF13G2	100	80	65	95	70	6	48	8	60	23	145	55	93	6.6	25	16	M4	8
HC-KF13G2	100	80	65	95	70	6	48	8	60	23	161	55	109	6.6	25	16	M4	8
HC-KF13G2	100	100	80	115	85	6	65	10	74	33	167	75	115	6.6	35	20	M5	10
HC-KF13G2	100	100	80	115	85	6	65	10	74	33	167	75	115	6.6	35	20	M5	10

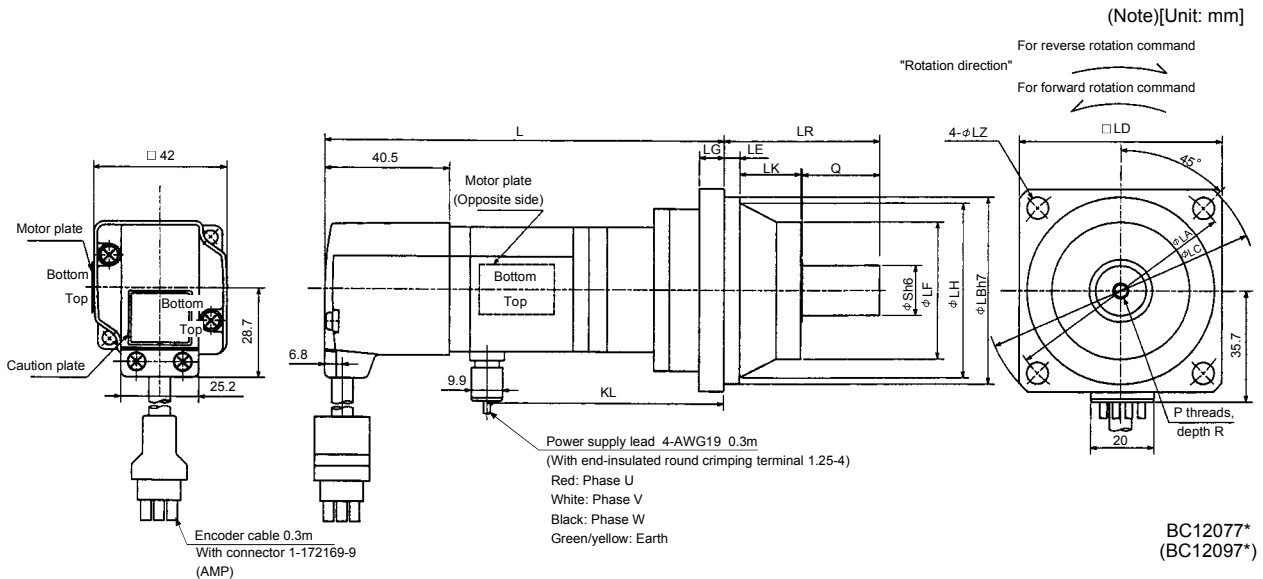

Note: The dimensions without tolerances are reference dimensions.

7. OUTLINE DIMENSION DRAWINGS

Model	Output [W]	Reduction Gear Model	Reduction Ratio	Inertia Moment $J[\times 10^{-4} \text{kg} \cdot \text{m}^2]$	Mass [kg]
HC-MF23G2	200	BK1-05B-02MEKA	1/5	0.191	2.1
HC-MF23G2	200	BK2-09B-02MEKA	1/9	0.208	3.5
HC-MF23G2	200	BK3-20B-02MEKA	1/20	0.357	5.0
HC-MF23G2	200	BK3-29B-02MEKA	1/29	0.276	5.0

Model	Output [W]	Variable Dimensions																
		LA	LB	LC	LD	LE	LF	LG	LH	LK	L	LR	KL	LZ	Q	S	P	R
HC-MF23G2	200	80	65	95	70	6	48	8	60	23	157	55	106.6	6.6	25	16	M4	8
HC-MF23G2	200	100	80	115	85	6	65	10	74	33	175	75	124.6	6.6	35	20	M5	10
HC-MF23G2	200	115	95	135	100	8	75	10	85	35	180	85	129.6	9	40	25	M6	12
HC-MF23G2	200	115	95	135	100	8	75	10	85	35	180	85	129.6	9	40	25	M6	12

Model	Output [W]	Reduction Gear Model	Reduction Ratio	Inertia Moment $J[\times 10^{-4} \text{kg} \cdot \text{m}^2]$	Mass [kg]
HC-KF23G2	200	BK1-05B-02MEKA	1/5	0.360	2.1
HC-KF23G2	200	BK2-09B-02MEKA	1/9	0.380	3.5
HC-KF23G2	200	BK3-20B-02MEKA	1/20	0.530	5.0
HC-KF23G2	200	BK3-29B-02MEKA	1/29	0.450	5.0

Model	Output [W]	Variable Dimensions																
		LA	LB	LC	LD	LE	LF	LG	LH	LK	L	LR	KL	LZ	Q	S	P	R
HC-KF23G2	200	80	65	95	70	6	48	8	60	23	157	55	106.6	6.6	25	16	M4	8
HC-KF23G2	200	100	80	115	85	6	65	10	74	33	175	75	124.6	6.6	35	20	M5	10
HC-KF23G2	200	115	95	135	100	8	75	10	85	35	180	85	129.6	9	40	25	M6	12
HC-KF23G2	200	115	95	135	100	8	75	10	85	35	180	85	129.6	9	40	25	M6	12

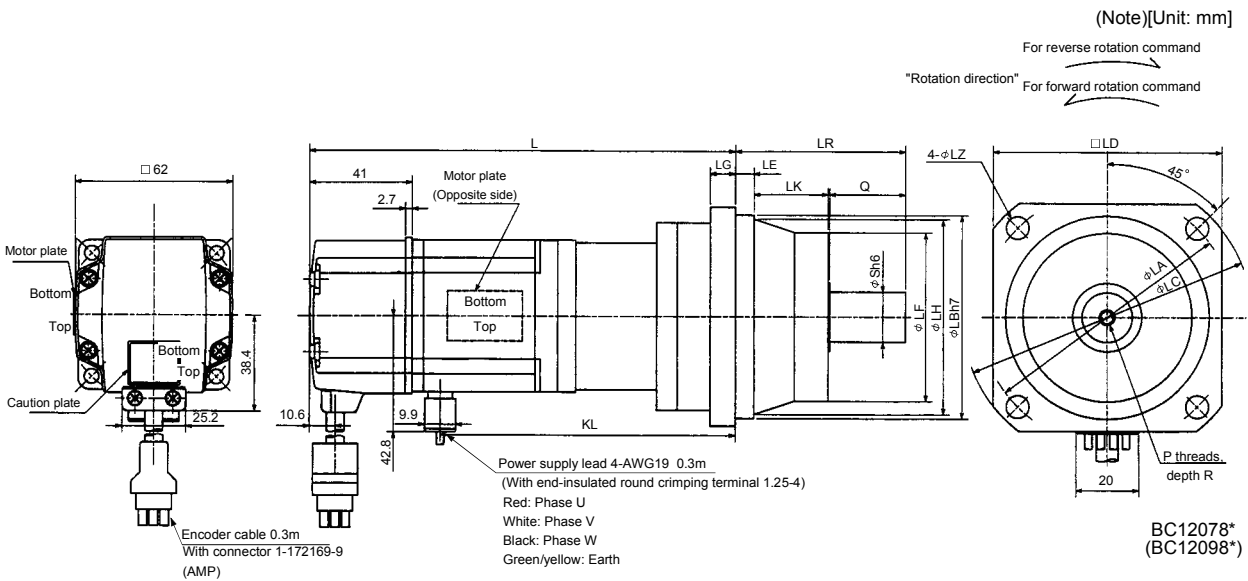

Note: The dimensions without tolerances are reference dimensions.

7. OUTLINE DIMENSION DRAWINGS

Model	Output [W]	Reduction Gear Model	Reduction Ratio	Inertia Moment $J[\times 10^{-4} \text{kg} \cdot \text{m}^2]$	Mass [kg]
HC-MF43G2	400	BK2-05B-04MEKA	1/5	0.295	3.7
HC-MF43G2	400	BK3-09B-04MEKA	1/9	0.323	5.3
HC-MF43G2	400	BK4-20B-04MEKA	1/20	0.426	7.5
HC-MF43G2	400	BK4-29B-04MEKA	1/29	0.338	7.5

Model	Output [W]	Variable Dimensions																
		LA	LB	LC	LD	LE	LF	LG	LH	LK	L	LR	KL	LZ	Q	S	P	R
HC-MF43G2	400	100	80	115	85	6	65	10	74	33	184	75	131.6	6.6	35	20	M5	10
HC-MF43G2	400	115	95	135	100	8	75	10	85	35	205	85	152.6	9	40	25	M6	12
HC-MF43G2	400	135	110	155	115	8	90	12	100	40	211	100	158.6	11	50	32	M8	16
HC-MF43G2	400	135	110	155	115	8	90	12	100	40	211	100	158.6	11	50	32	M8	16

Model	Output [W]	Reduction Gear Model	Reduction Ratio	Inertia Moment $J[\times 10^{-4} \text{kg} \cdot \text{m}^2]$	Mass [kg]
HC-KF43G2	400	BK2-05B-04MEKA	1/5	0.610	3.7
HC-KF43G2	400	BK3-09B-04MEKA	1/9	0.640	5.3
HC-KF43G2	400	BK4-20B-04MEKA	1/20	0.740	7.5
HC-KF43G2	400	BK4-29B-04MEKA	1/29	0.660	7.5

Model	Output [W]	Variable Dimensions																
		LA	LB	LC	LD	LE	LF	LG	LH	LK	L	LR	KL	LZ	Q	S	P	R
HC-KF43G2	400	100	80	115	85	6	65	10	74	33	184	75	131.6	6.6	35	20	M5	10
HC-KF43G2	400	115	95	135	100	8	75	10	85	35	205	85	152.6	9	40	25	M6	12
HC-KF43G2	400	135	110	155	115	8	90	12	100	40	211	100	158.6	11	50	32	M8	16
HC-KF43G2	400	135	110	155	115	8	90	12	100	40	211	100	158.6	11	50	32	M8	16

(Note)[Unit: mm]

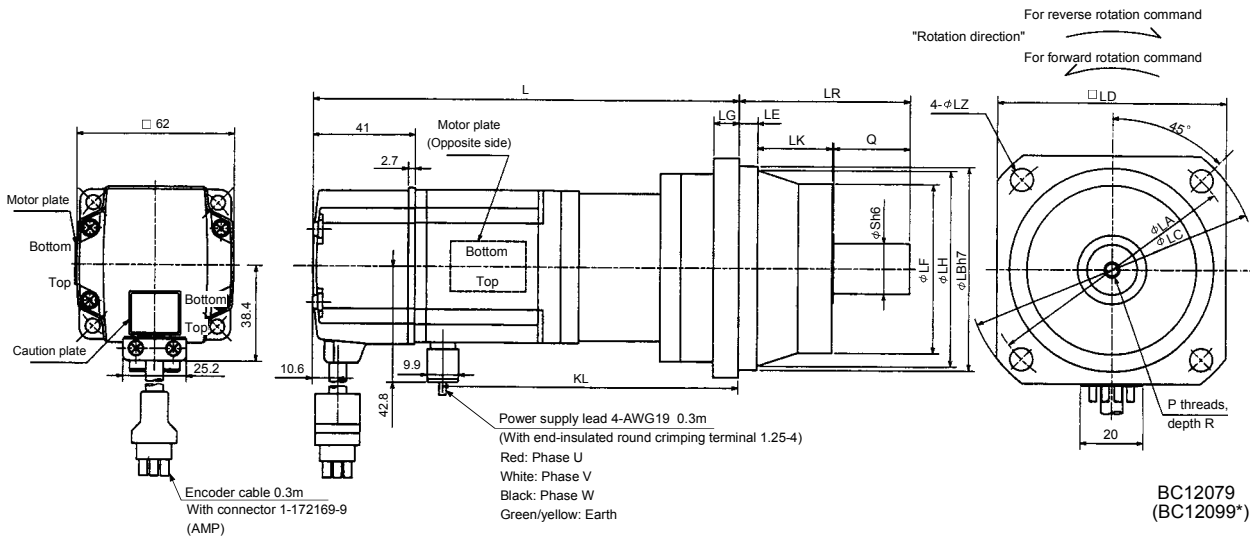

BC12079
(BC12099*)

Note: The dimensions without tolerances are reference dimensions.

7. OUTLINE DIMENSION DRAWINGS

Model	Output [W]	Reduction Gear Model	Reduction Ratio	Inertia Moment $J[\times 10^{-4} \text{kg} \cdot \text{m}^2]$	Mass [kg]
HC-MF73G2	750	BK3-05B-08MEKA	1/5	0.973	6.3
HC-MF73G2	750	BK4-09B-08MEKA	1/9	0.980	8.6
HC-MF73G2	750	BK5-20B-08MEKA	1/20	1.016	12.0
HC-MF73G2	750	BK5-29B-08MEKA	1/29	0.910	12.0

Model	Output [W]	Variable Dimensions																
		LA	LB	LC	LD	LE	LF	LG	LH	LK	L	LR	KL	LZ	Q	S	P	R
HC-MF73G2	750	115	95	135	100	8	75	10	85	35	212	85	156.7	9	40	25	M6	12
HC-MF73G2	750	135	110	155	115	8	90	12	100	40	248	100	184.7	11	50	32	M8	16
HC-MF73G2	750	150	125	175	130	10	105	15	115	43	248	115	192.7	14	60	40	M10	20
HC-MF73G2	750	150	125	175	130	10	105	15	115	43	248	115	192.7	14	60	40	M10	20

(Note)[Unit: mm]

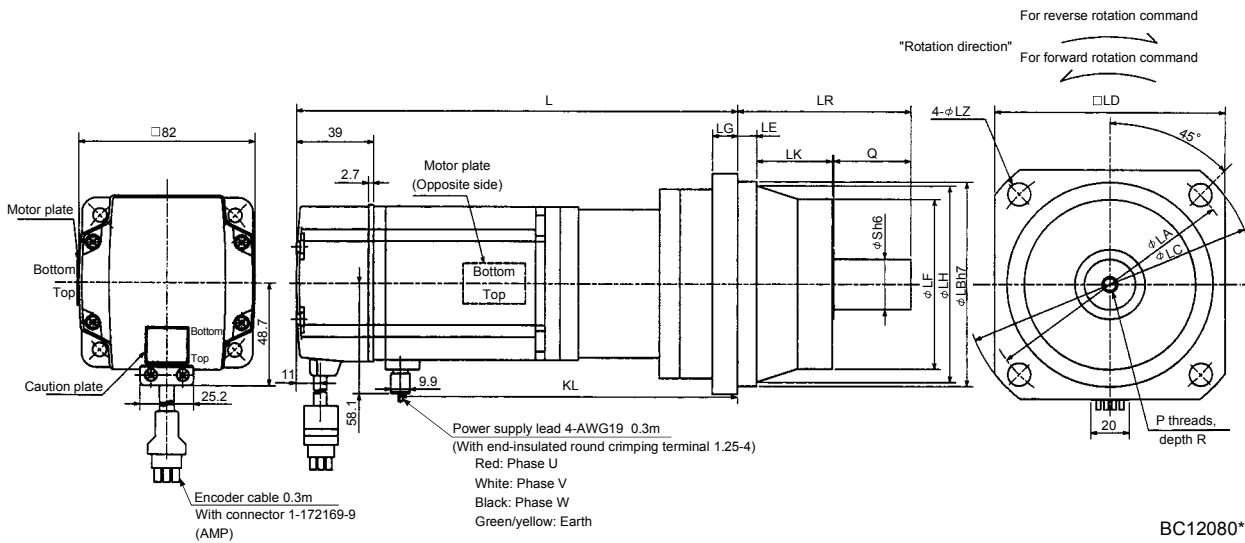

Note: The dimensions without tolerances are reference dimensions.

BC12080*

7. OUTLINE DIMENSION DRAWINGS

(b) With electromagnetic brake

Model	Output [W]	Variable Dimensions		Brake static friction torque [N · m]	Reduction Gear Model	Reduction Ratio	Inertia Moment J [$\times 10^{-4}$ kg · m ²]	Backlash	Mass [kg]
		L	KL						
HC-MF053BG2	50	158	78	0.32	BK1-05B-A5MEKA	1/5	0.070	3 min. max.	1.8
HC-MF053BG2	50	174	94	0.32	BK1-09B-A5MEKA	1/9	0.063	3 min. max.	2.1
HC-MF053BG2	50	174	94	0.32	BK1-20B-A5MEKA	1/20	0.072	3 min. max.	2.2
HC-MF053BG2	50	174	94	0.32	BK1-29B-A5MEKA	1/29	0.060	3 min. max.	2.2
HC-KF053BG2	50	158	78	0.32	BK1-05B-A5MEKA	1/5	0.104	3 min. max.	1.8
HC-KF053BG2	50	174	94	0.32	BK1-09B-A5MEKA	1/9	0.098	3 min. max.	2.1
HC-KF053BG2	50	174	94	0.32	BK1-20B-A5MEKA	1/20	0.107	3 min. max.	2.2
HC-KF053BG2	50	174	94	0.32	BK1-29B-A5MEKA	1/29	0.095	3 min. max.	2.2

(Note)[Unit: mm]

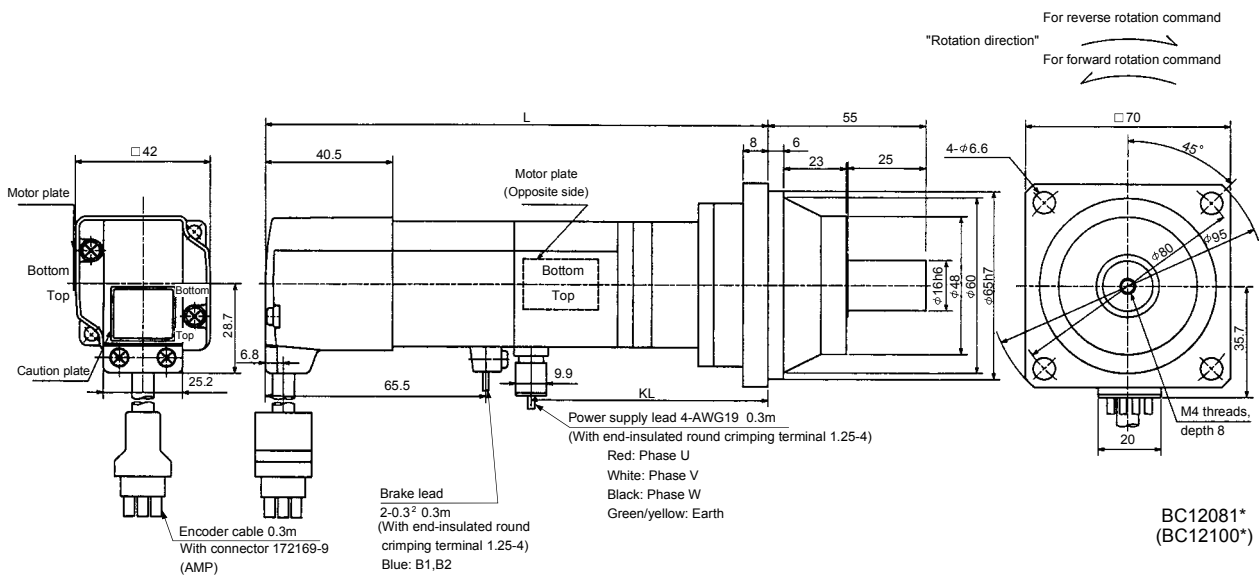

Note: The dimensions without tolerances are reference dimensions.

7. OUTLINE DIMENSION DRAWINGS

Model	Output [W]	Brake static friction torque [N · m]	Reduction Gear Model	Reduction Ratio	Inertia Moment $J[\times 10^{-4} \text{kg} \cdot \text{m}^2]$	Backlash	Mass [kg]
HC-MF13BG2	100	0.32	BK1-05B-01MEKA	1/5	0.080	3 min. max.	1.9
HC-MF13BG2	100	0.32	BK1-09B-01MEKA	1/9	0.074	3 min. max.	2.2
HC-MF13BG2	100	0.32	BK2-20B-01MEKA	1/20	0.124	3 min. max.	3.4
HC-MF13BG2	100	0.32	BK2-29B-01MEKA	1/29	0.098	3 min. max.	3.4

Model	Output [W]	Variable Dimensions																
		LA	LB	LC	LD	LE	LF	LG	LH	LK	L	LR	KL	LZ	Q	S	P	R
HC-MF13BG2	100	80	65	95	70	6	48	8	60	23	173	55	93	6.6	25	16	M4	8
HC-MF13BG2	100	80	65	95	70	6	48	8	60	23	189	55	109	6.6	25	16	M4	8
HC-MF13BG2	100	100	80	115	85	6	65	10	74	33	195	75	115	6.6	35	20	M5	10
HC-MF13BG2	100	100	80	115	85	6	65	10	74	33	195	75	115	6.6	35	20	M5	10

Model	Output [W]	Brake static friction torque [N · m]	Reduction Gear Model	Reduction Ratio	Inertia Moment $J[\times 10^{-4} \text{kg} \cdot \text{m}^2]$	Backlash	Mass [kg]
HC-KF13BG2	100	0.32	BK1-05B-01MEKA	1/5	0.135	3 min. max.	1.9
HC-KF13BG2	100	0.32	BK1-09B-01MEKA	1/9	0.129	3 min. max.	2.2
HC-KF13BG2	100	0.32	BK2-20B-01MEKA	1/20	0.179	3 min. max.	3.4
HC-KF13BG2	100	0.32	BK2-29B-01MEKA	1/29	0.153	3 min. max.	3.4

Model	Output [W]	Variable Dimensions																
		LA	LB	LC	LD	LE	LF	LG	LH	LK	L	LR	KL	LZ	Q	S	P	R
HC-KF13BG2	100	80	65	95	70	6	48	8	60	23	173	55	93	6.6	25	16	M4	8
HC-KF13BG2	100	80	65	95	70	6	48	8	60	23	189	55	109	6.6	25	16	M4	8
HC-KF13BG2	100	100	80	115	85	6	65	10	74	33	195	75	115	6.6	35	20	M5	10
HC-KF13BG2	100	100	80	115	85	6	65	10	74	33	195	75	115	6.6	35	20	M5	10

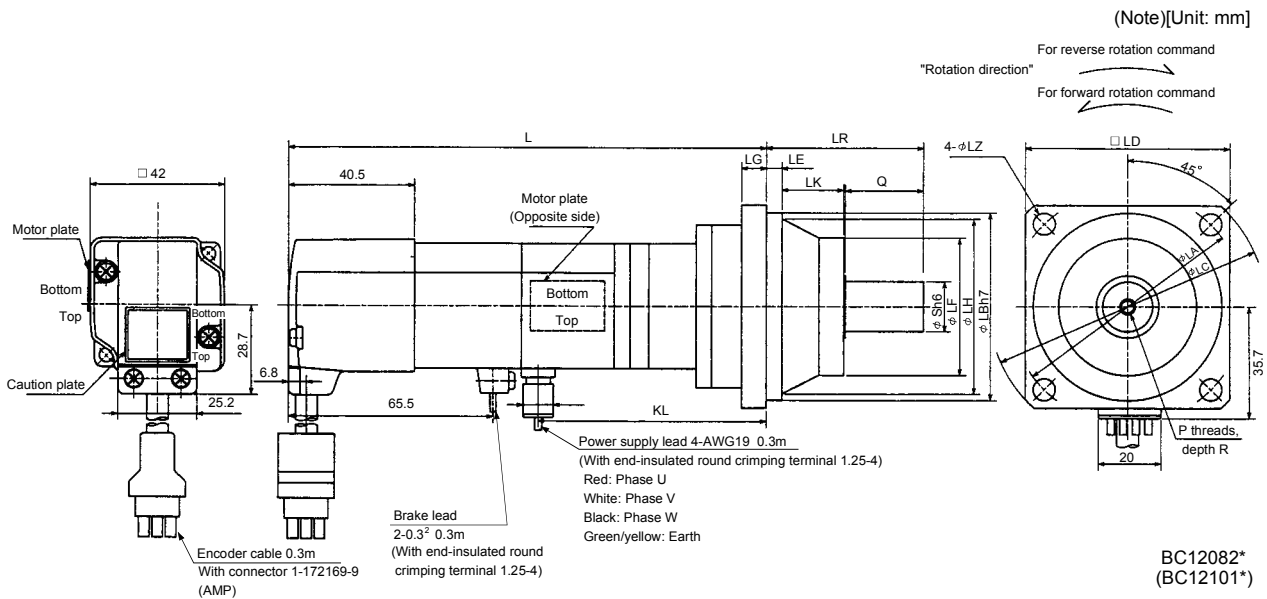

Note: The dimensions without tolerances are reference dimensions.

BC12082*
(BC12101*)

7. OUTLINE DIMENSION DRAWINGS

Model	Output [W]	Brake static friction torque [N · m]	Reduction Gear Model	Reduction Ratio	Inertia Moment $J[\times 10^{-4} \text{ kg} \cdot \text{m}^2]$	Mass [kg]
HC-MF23BG2	200	1.3	BK1-05B-02MEKA	1/5	0.239	2.7
HC-MF23BG2	200	1.3	BK2-09B-02MEKA	1/9	0.256	4.1
HC-MF23BG2	200	1.3	BK3-20B-02MEKA	1/20	0.405	5.6
HC-MF23BG2	200	1.3	BK3-29B-02MEKA	1/29	0.324	5.6

Model	Output [W]	Variable Dimensions																
		LA	LB	LC	LD	LE	LF	LG	LH	LK	L	LR	KL	LZ	Q	S	P	R
HC-MF23BG2	200	80	65	95	70	6	48	8	60	23	189	55	106.6	6.6	25	16	M4	8
HC-MF23BG2	200	100	80	115	85	6	65	10	74	33	207	75	124.6	6.6	35	20	M5	10
HC-MF23BG2	200	115	95	135	100	8	75	10	85	35	212	85	129.6	9	40	25	M6	12
HC-MF23BG2	200	115	95	135	100	8	75	10	85	35	212	85	129.6	9	40	25	M6	12

Model	Output [W]	Brake static friction torque [N · m]	Reduction Gear Model	Reduction Ratio	Inertia Moment $J[\times 10^{-4} \text{ kg} \cdot \text{m}^2]$	Mass [kg]
HC-KF23BG2	200	1.3	BK1-05B-02MEKA	1/5	0.410	2.7
HC-KF23BG2	200	1.3	BK2-09B-02MEKA	1/9	0.430	4.1
HC-KF23BG2	200	1.3	BK3-20B-02MEKA	1/20	0.580	5.6
HC-KF23BG2	200	1.3	BK3-29B-02MEKA	1/29	0.500	5.6

Model	Output [W]	Variable Dimensions																
		LA	LB	LC	LD	LE	LF	LG	LH	LK	L	LR	KL	LZ	Q	S	P	R
HC-KF23BG2	200	80	65	95	70	6	48	8	60	23	189	55	106.6	6.6	25	16	M4	8
HC-KF23BG2	200	100	80	115	85	6	65	10	74	33	207	75	124.6	6.6	35	20	M5	10
HC-KF23BG2	200	115	95	135	100	8	75	10	85	35	212	85	129.6	9	40	25	M6	12
HC-KF23BG2	200	115	95	135	100	8	75	10	85	35	212	85	129.6	9	40	25	M6	12

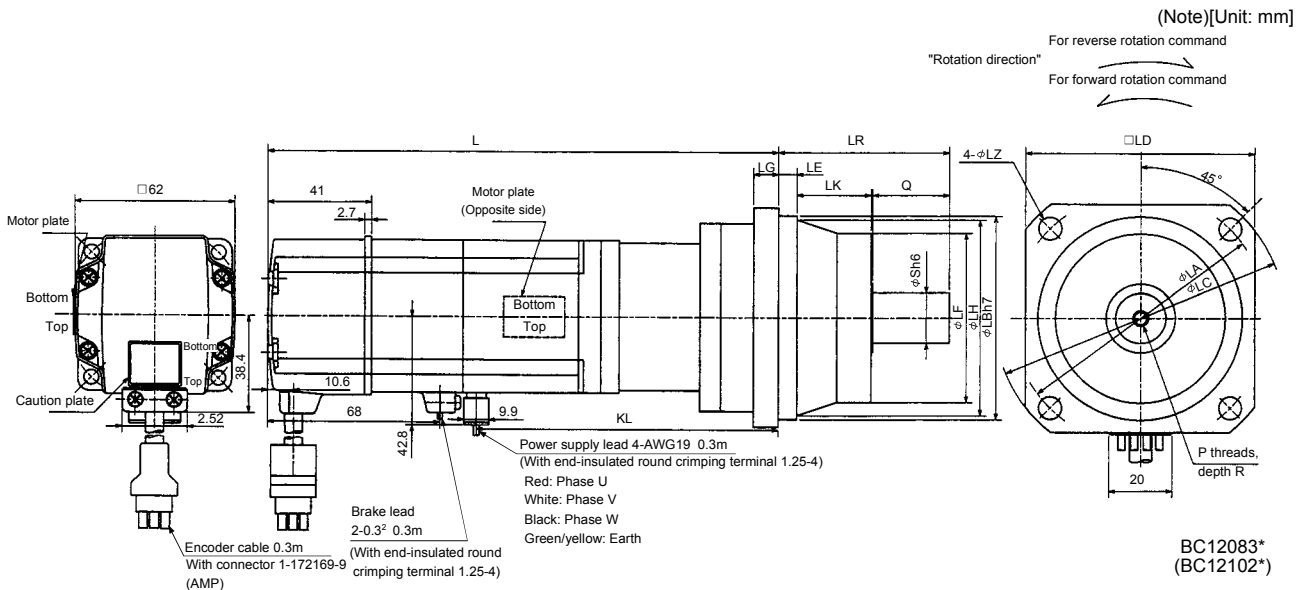

7. OUTLINE DIMENSION DRAWINGS

Model	Output [W]	Brake static friction torque [N · m]	Reduction Gear Model	Reduction Ratio	Inertia Moment $J[\times 10^{-4} \text{kg} \cdot \text{m}^2]$	Mass [kg]
HC-MF43BG2	400	1.3	BK2-05B-04MEKA	1/5	0.344	4.3
HC-MF43BG2	400	1.3	BK3-09B-04MEKA	1/9	0.372	5.9
HC-MF43BG2	400	1.3	BK4-20B-04MEKA	1/20	0.475	8.1
HC-MF43BG2	400	1.3	BK4-29B-04MEKA	1/29	0.386	8.1

Model	Output [W]	Variable Dimensions																
		LA	LB	LC	LD	LE	LF	LG	LH	LK	L	LR	KL	LZ	Q	S	P	R
HC-MF43BG2	400	100	80	115	85	6	65	10	74	33	216	75	131.6	6.6	35	20	M5	10
HC-MF43BG2	400	115	95	135	100	8	75	10	85	35	237	85	152.6	9	40	25	M6	12
HC-MF43BG2	400	135	110	155	115	8	90	12	100	40	243	100	158.6	11	50	32	M8	16
HC-MF43BG2	400	135	110	155	115	8	90	12	100	40	243	100	158.6	11	50	32	M8	16

Model	Output [W]	Brake static friction torque [N · m]	Reduction Gear Model	Reduction Ratio	Inertia Moment $J[\times 10^{-4} \text{kg} \cdot \text{m}^2]$	Mass [kg]
HC-KF43BG2	400	1.3	BK2-05B-04MEKA	1/5	0.660	4.3
HC-KF43BG2	400	1.3	BK3-09B-04MEKA	1/9	0.690	5.9
HC-KF43BG2	400	1.3	BK4-20B-04MEKA	1/20	0.790	8.1
HC-KF43BG2	400	1.3	BK4-29B-04MEKA	1/29	0.710	8.1

Model	Output [W]	Variable Dimensions																
		LA	LB	LC	LD	LE	LF	LG	LH	LK	L	LR	KL	LZ	Q	S	P	R
HC-KF43BG2	400	100	80	115	85	6	65	10	74	33	216	75	131.6	6.6	35	20	M5	10
HC-KF43BG2	400	115	95	135	100	8	75	10	85	35	237	85	152.6	9	40	25	M6	12
HC-KF43BG2	400	135	110	155	115	8	90	12	100	40	243	100	158.6	11	50	32	M8	16
HC-KF43BG2	400	135	110	155	115	8	90	12	100	40	243	100	158.6	11	50	32	M8	16

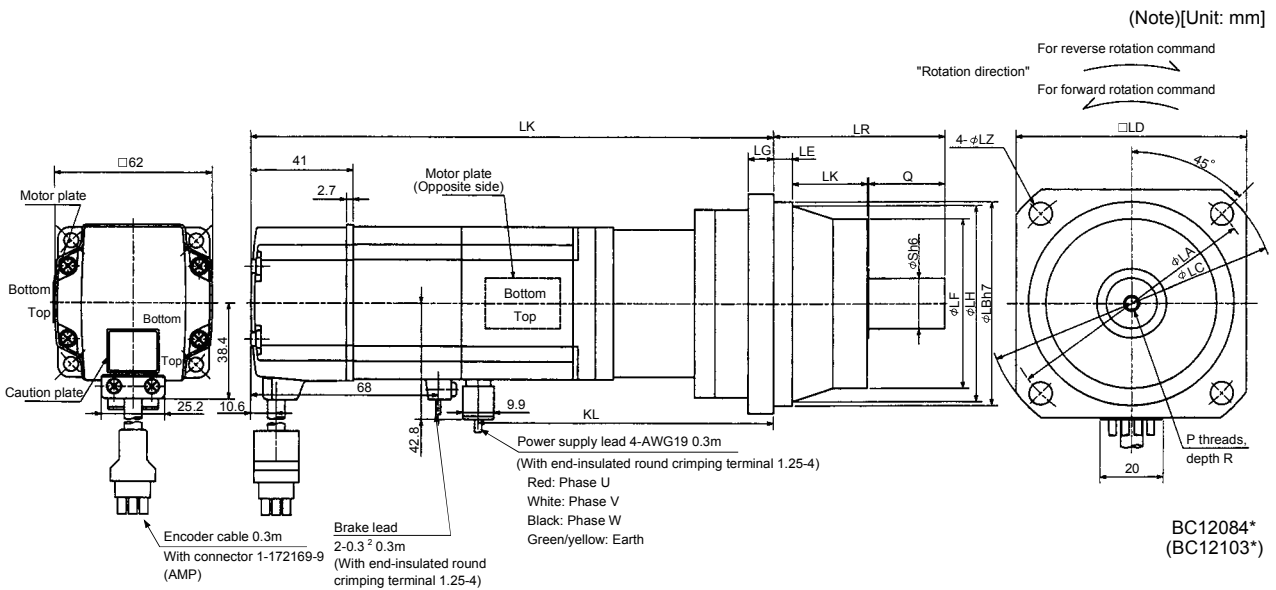

Note: The dimensions without tolerances are reference dimensions.

7. OUTLINE DIMENSION DRAWINGS

Model	Output [W]	Brake static friction torque [N · m]	Reduction Gear Model	Reduction Ratio	Inertia Moment $J[\times 10^{-4} \text{kg} \cdot \text{m}^2]$	Mass [kg]
HC-MF73BG2	750	2.4	BK3-05B-08MEKA	1/5	1.098	7.3
HC-MF73BG2	750	2.4	BK4-09B-08MEKA	1/9	1.105	9.6
HC-MF73BG2	750	2.4	BK5-20B-08MEKA	1/20	1.141	13.0
HC-MF73BG2	750	2.4	BK5-29B-08MEKA	1/29	1.035	13.0

Model	Output [W]	Variable Dimensions																
		LA	LB	LC	LD	LE	LF	LG	LH	LK	L	LR	KL	LZ	Q	S	P	R
HC-MF73BG2	750	115	95	135	100	8	75	10	85	35	247.5	85	156.7	9	40	25	M6	12
HC-MF73BG2	750	135	110	155	115	8	90	12	100	40	275.5	100	184.7	11	50	32	M8	16
HC-MF73BG2	750	150	125	175	130	10	105	15	115	43	283.5	115	192.7	14	60	40	M10	20
HC-MF73BG2	750	150	125	175	130	10	105	15	115	43	283.5	115	192.7	14	60	40	M10	20

(Note)[Unit: mm]

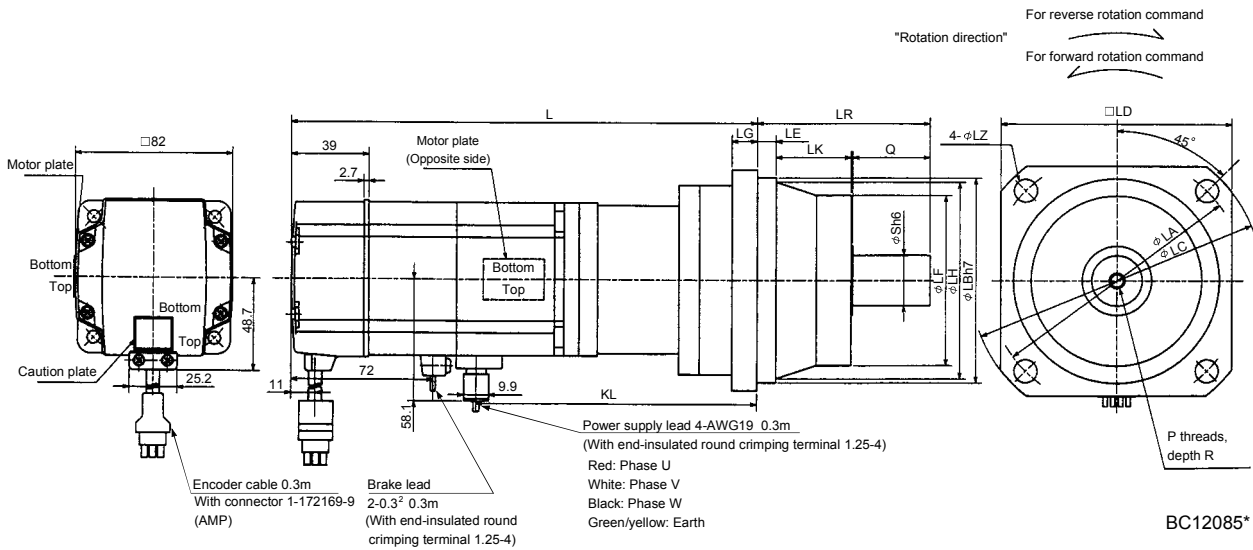

7. OUTLINE DIMENSION DRAWINGS

(5) EN · UL/C-UL Standard-compliant models

(a) Standard (without electromagnetic brake, without reduction gear)

Model	Output [W]	Variable Dimensions		Inertia Moment $J[\times 10^{-4} \text{ kg} \cdot \text{m}^2]$	Mass [kg]
		L	KL		
HC-MF053-UE	50	89.5	37.5	0.019	0.5
HC-MF13-UE	100	104.5	52.5	0.03	0.6
HC-KF053-UE	50	89.5	37.5	0.054	0.5
HC-KF13-UE	100	104.5	52.5	0.085	0.6

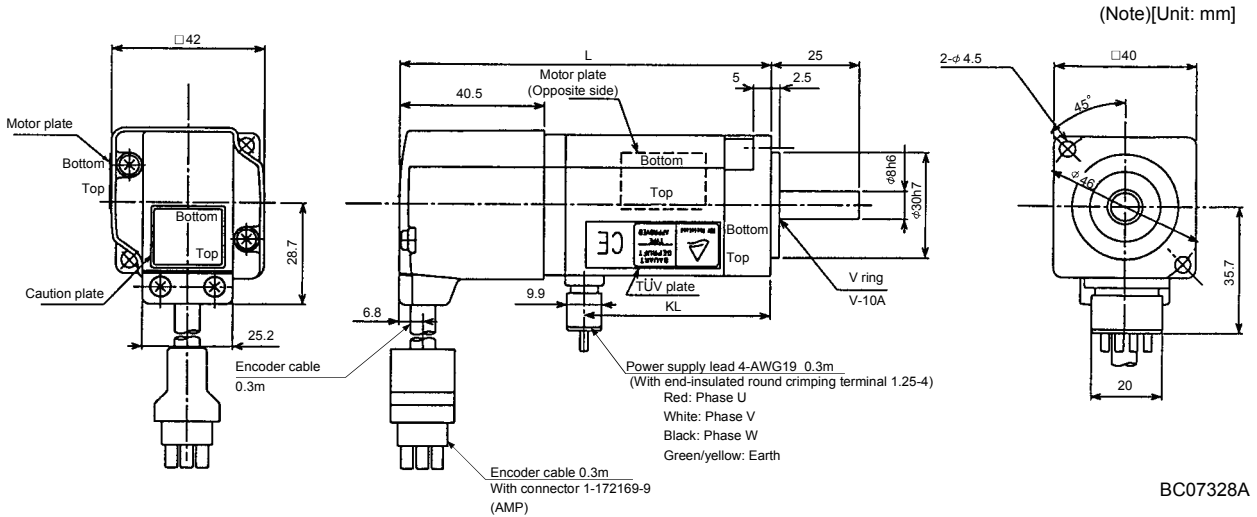

Note: The dimensions without tolerances are reference dimensions.

Model	Output [W]	Variable Dimensions		Inertia Moment $J[\times 10^{-4} \text{ kg} \cdot \text{m}^2]$	Mass [kg]
		L	KL		
HC-MF23-UE	200	108.5	58	0.09	1.2
HC-MF43-UE	400	133.5	81	0.14	1.7
HC-KF23-UE	200	108.5	58	0.270	1.2
HC-KF43-UE	400	133.5	81	0.470	1.7

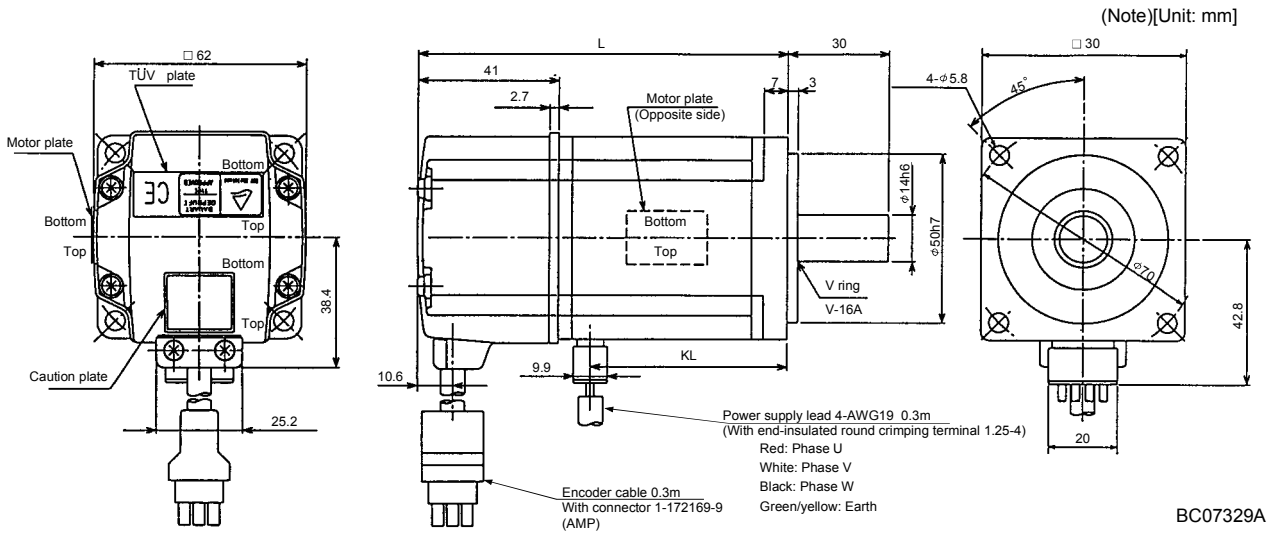

Note: The dimensions without tolerances are reference dimensions.

7. OUTLINE DIMENSION DRAWINGS

Model	Output [W]	Inertia Moment $J[\times 10^{-4} \text{ kg} \cdot \text{m}^2]$	Mass [kg]
HC-MF73-UE	750	0.675	3.1

(Note)[Unit: mm]

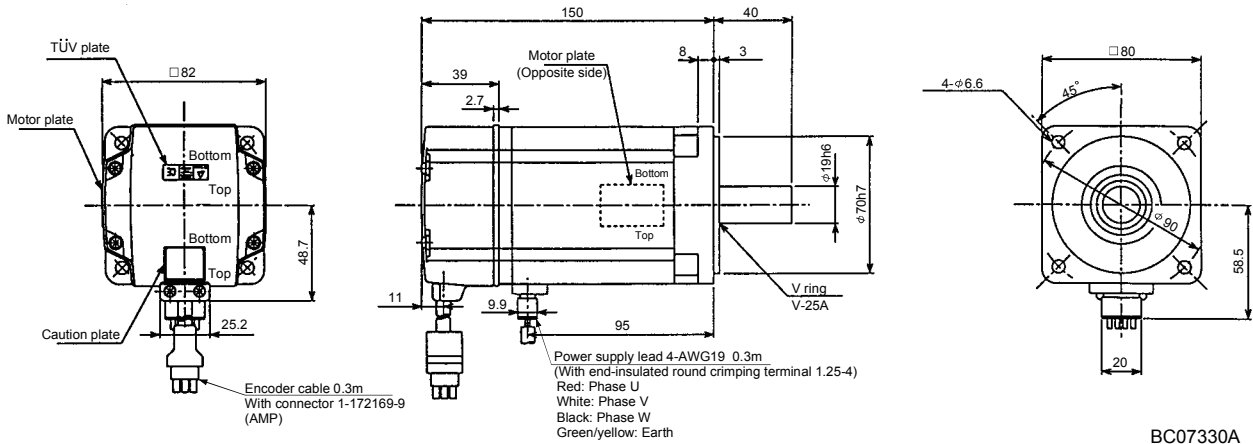

Note: The dimensions without tolerances are reference dimensions.

(b) With electromagnetic brake

Model	Output [W]	Variable Dimensions		Brake static friction torque [N · m]	Inertia Moment $J[\times 10^{-4} \text{ kg} \cdot \text{m}^2]$	Mass [kg]
		L	KL			
HC-MF053B-UE	50	117.5	37.5	0.32	0.022	0.9
HC-MF13B-UE	100	132.5	52.5		0.032	1
HC-KF053B-UE	50	117.5	37.5		0.057	0.9
HC-KF13B-UE	100	132.5	52.5		0.088	1

(Note)[Unit: mm]

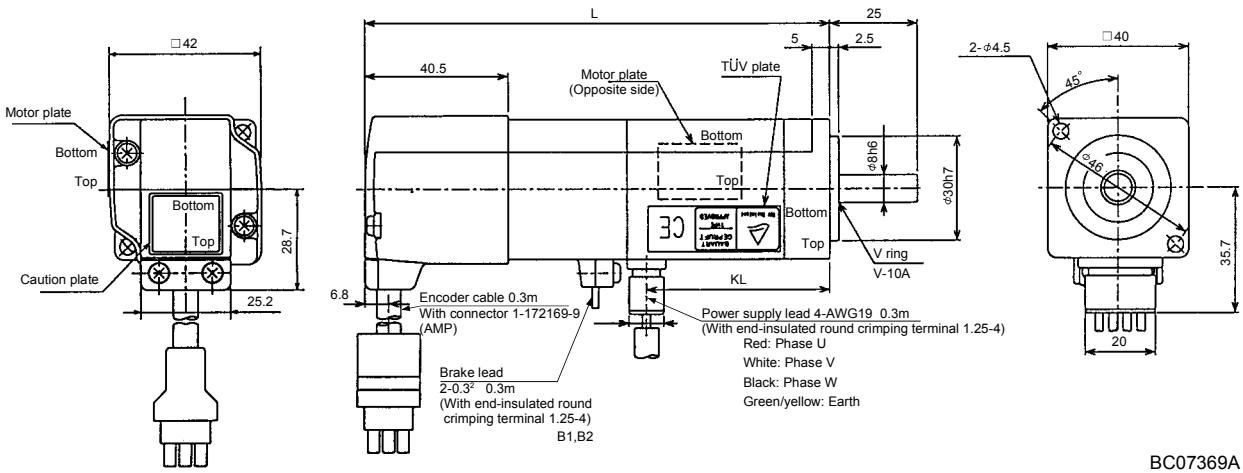

Note: The dimensions without tolerances are reference dimensions.

7. OUTLINE DIMENSION DRAWINGS

Model	Output [W]	Variable Dimensions		Brake static friction torque [N · m]	Inertia Moment J [$\times 10^{-4}$ kg · m ²]	Mass [kg]
		L	KL			
HC-MF23B-UE	200	140.5	58	1.3	0.136	1.7
HC-MF43B-UE	400	165.5	81		0.191	2.2
HC-KF23B-UE	200	140.5	58		0.320	1.7
HC-KF43B-UE	400	165.5	81		0.520	2.2

(Note)[Unit: mm]

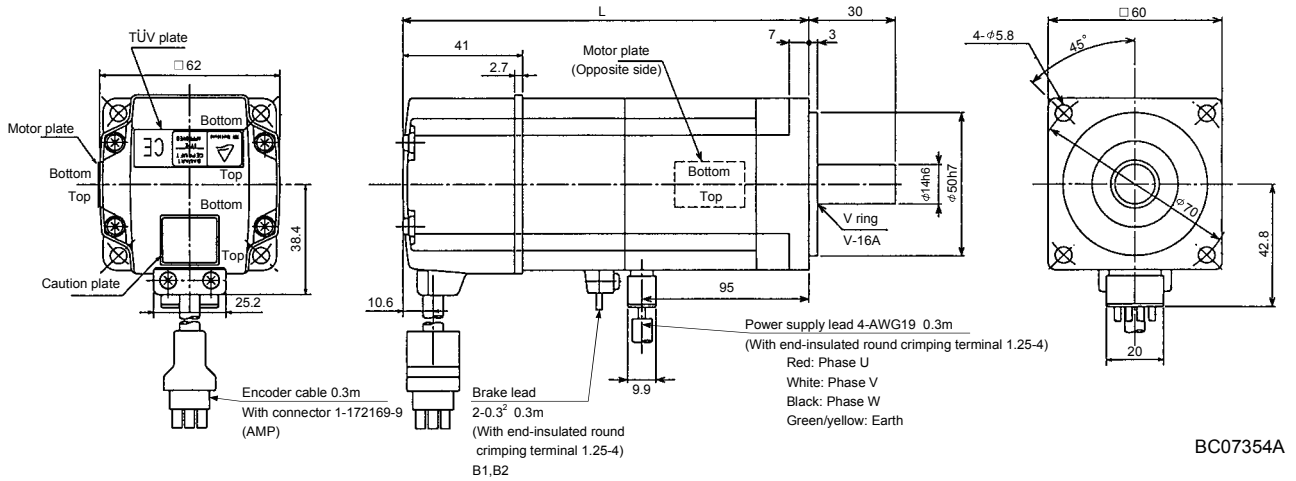

BC07354A

Note: The dimensions without tolerances are reference dimensions.

Model	Output [W]	Brake static friction torque [N · m]	Inertia Moment J [$\times 10^{-4}$ kg · m ²]	Mass [kg]
HC-MF73B-UE	750	2.4	0.75	4.2

(Note)[Unit: mm]

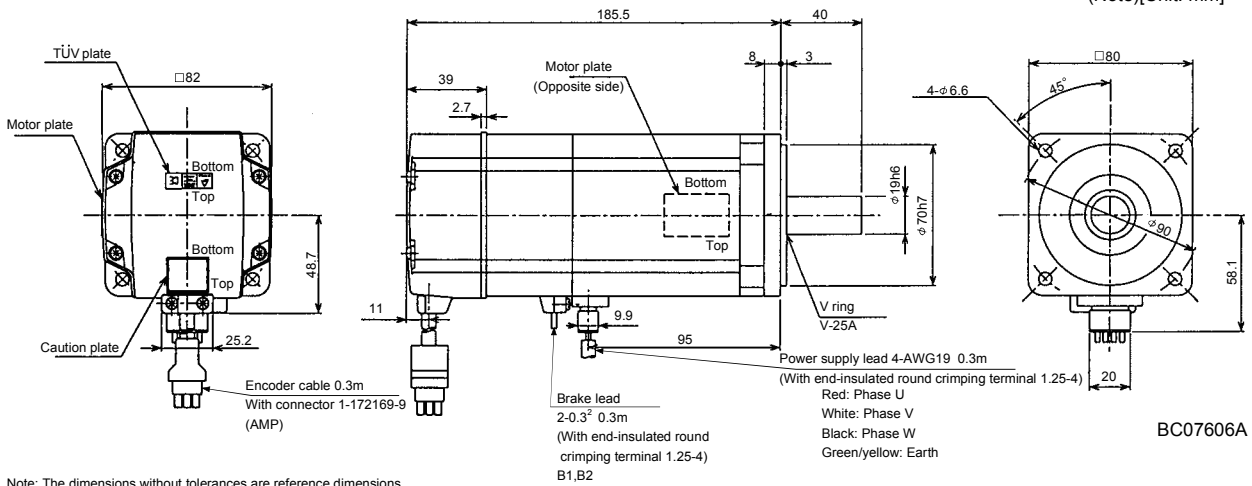

BC07606A

Note: The dimensions without tolerances are reference dimensions.

7. OUTLINE DIMENSION DRAWINGS

7.1.2 HA-FF series

(1) Standard (without electromagnetic brake, without reduction gear)

Model	Output [W]	Variable Dimensions L	Inertia Moment $J[\times 10^{-4} \text{kg} \cdot \text{m}^2]$	Mass [kg]
HA-FF053	50	106	0.063	1.3
HA-FF13	100	123	0.10	1.5

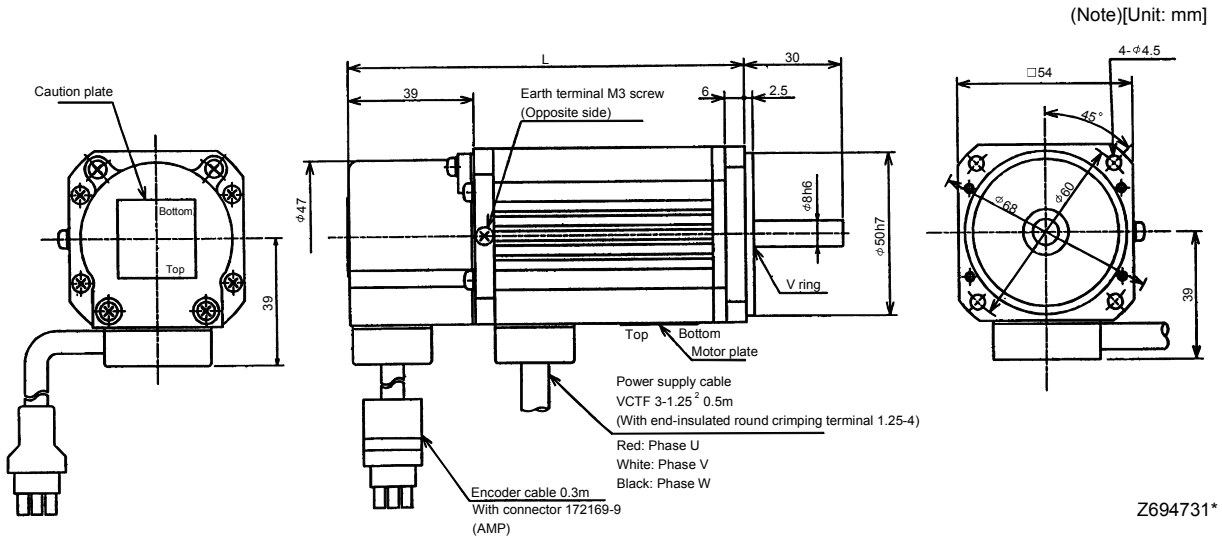

Note: The dimensions without tolerances are reference dimensions.

Model	Output [W]	Variable Dimensions L	Inertia Moment $J[\times 10^{-4} \text{kg} \cdot \text{m}^2]$	Mass [kg]
HA-FF23	200	130.5	0.35	2.3
HA-FF33	300	148	0.5	2.6

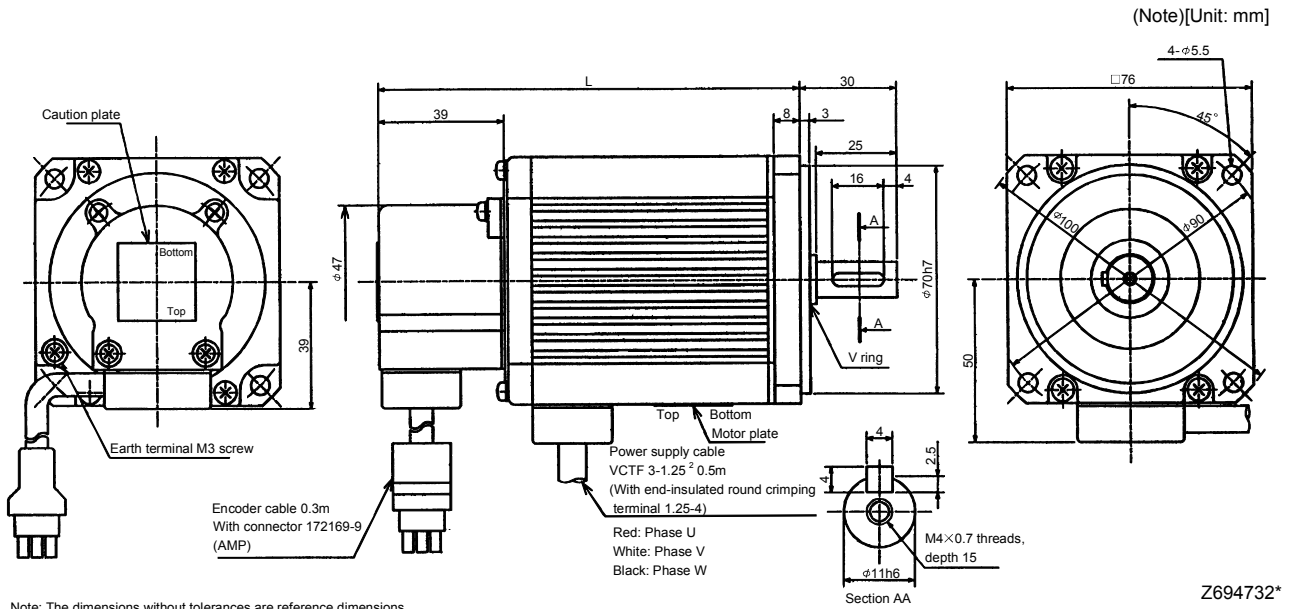

Note: The dimensions without tolerances are reference dimensions.

7. OUTLINE DIMENSION DRAWINGS

Model	Output [W]	Variable Dimensions L	Inertia Moment $J[\times 10^{-4} \text{ kg} \cdot \text{m}^2]$	Mass [kg]
HA-FF43	400	154.5	0.98	4.2
HA-FF63	600	169.5	1.2	4.8

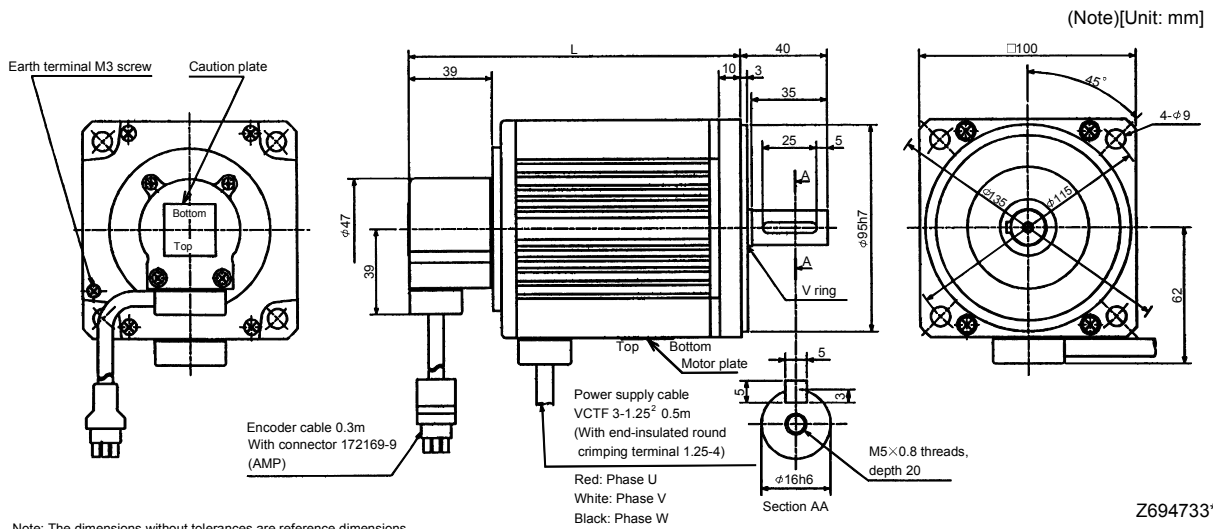

Note: The dimensions without tolerances are reference dimensions.

(2) Without electromagnetic brake

Model	Output [W]	Variable Dimensions L	Brake static friction torque [N · m]	Inertia Moment $J[\times 10^{-4} \text{ kg} \cdot \text{m}^2]$	Mass [kg]
HA-FF053B	50	141	0.39	0.08	1.6
HA-FF13B	100	158	0.39	0.11	1.8

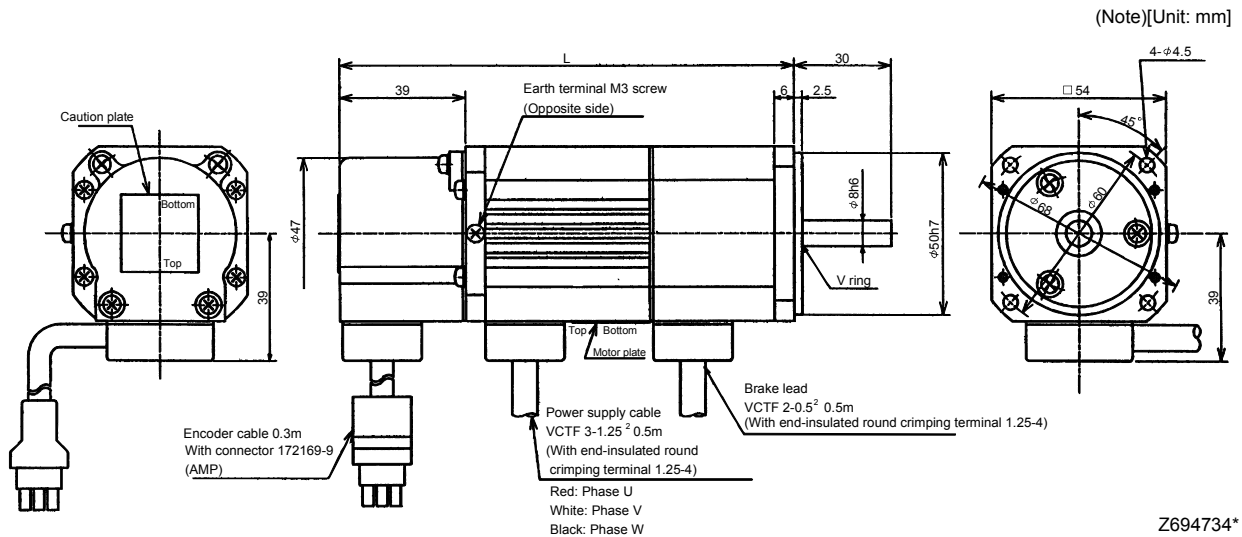

Note: The dimensions without tolerances are reference dimensions.

7. OUTLINE DIMENSION DRAWINGS

Model	Output [W]	Variable Dimensions L	Brake static friction torque [N · m]	Inertia Moment $J[\times 10^{-4} \text{kg} \cdot \text{m}^2]$	Mass [kg]
HA-FF23B	200	168	1.2	0.48	2.9
HA-FF33B	300	185.5	1.2	0.63	3.2

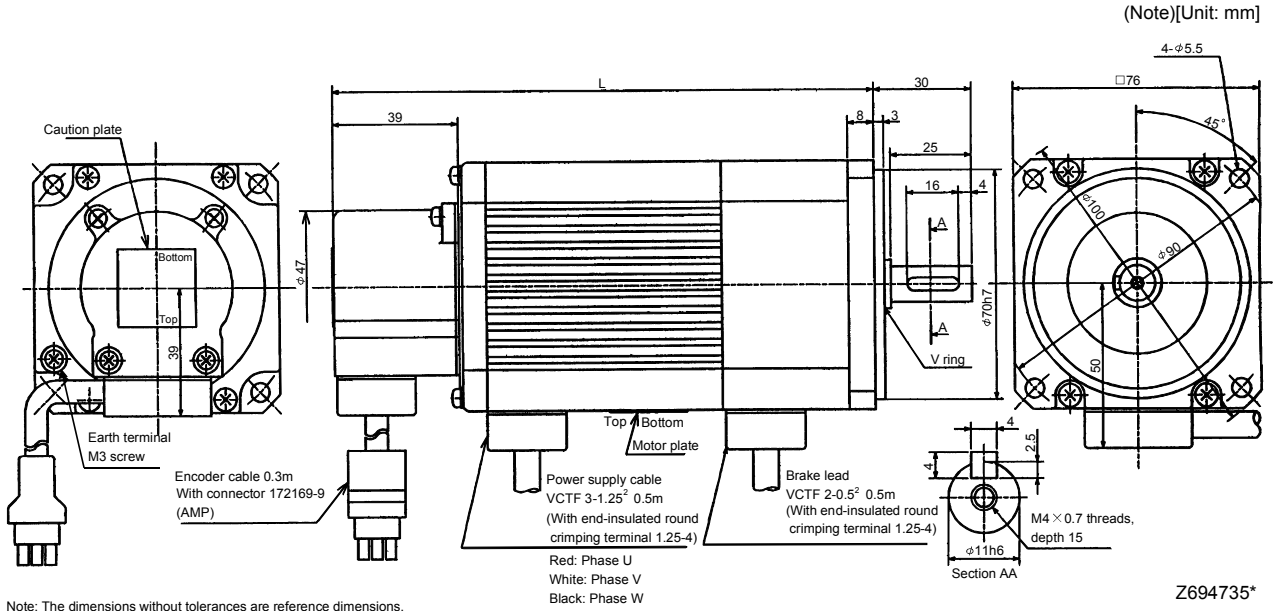

Model	Output [W]	Variable Dimensions L	Brake static friction torque [N · m]	Inertia Moment $J[\times 10^{-4} \text{kg} \cdot \text{m}^2]$	Mass [kg]
HA-FF43B	400	191.5	2.3	1.33	5.0
HA-FF63B	600	206.5	2.3	1.55	5.6

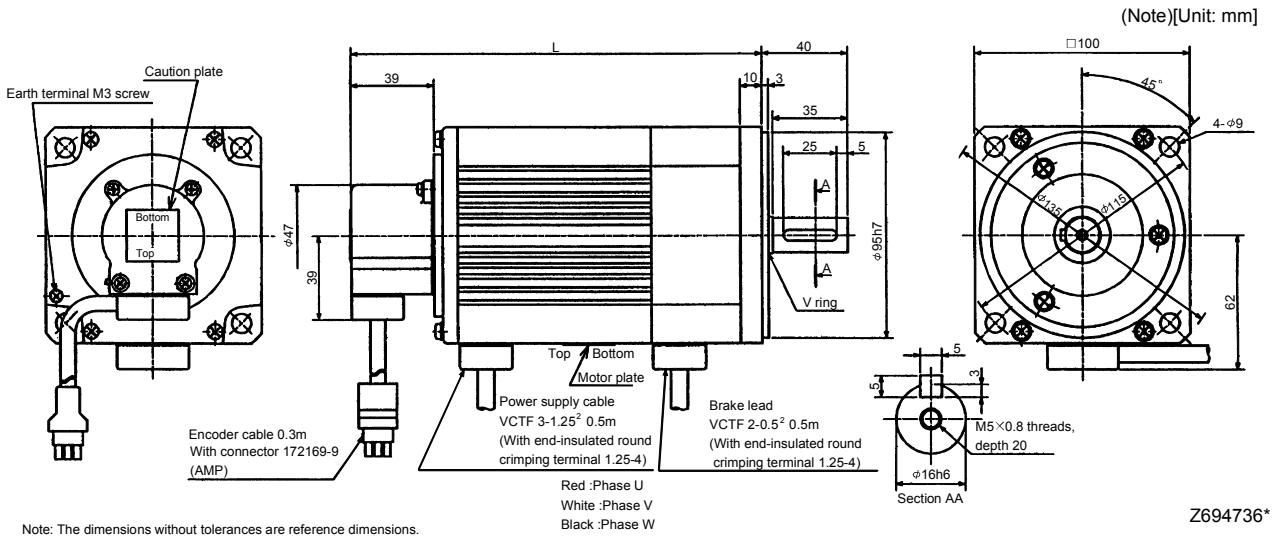

7. OUTLINE DIMENSION DRAWINGS

(3) With reduction gear for general industrial machine

The outer frame of the reduction gear is a material surface such as casting. Its actual dimensions may be 1 to 3mm larger than the drawing dimensions. Design the machine side with allowances.

(a) Without electromagnetic brake

Model	Output [W]	Reduction Gear Model	Reduction Ratio (Actual Reduction Ratio)	Inertia Moment $J[\times 10^{-4} \text{ kg} \cdot \text{m}^2]$	Backlash	Mass [kg]	Output Shaft Rotation Direction
HA-FF053G1	50	GR-S-10	1/5(9/44)	0.068	40min. to 1.5°	2.5	Same as that of motor shaft
			1/10(3/29)				
			1/20(99/1972)	0.063			Opposite to that of motor shaft
			1/30(144/4205)				

(Note1)[Unit: mm]

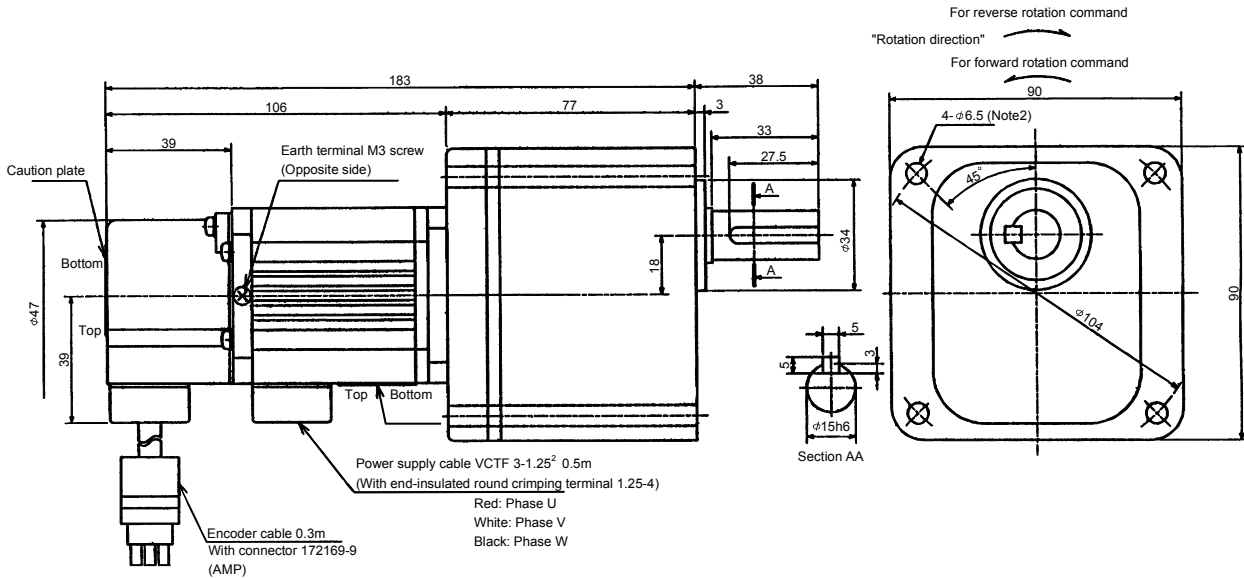

- Note: 1. The dimensions without tolerances are reference dimensions.
2. Four M6×90 through bolts are provided.

Z694764*

Model	Output [W]	Reduction Gear Model	Reduction Ratio (Actual Reduction Ratio)	Inertia Moment $J[\times 10^{-4} \text{ kg} \cdot \text{m}^2]$	Backlash	Mass [kg]	Output Shaft Rotation Direction
HA-FF13G1	100	GR-S-10	1/5(9/44)	0.10	40min. to 1.5°	2.7	Same as that of motor shaft
			1/10(3/29)				
			1/20(99/1972)	0.095			Opposite to that of motor shaft
			1/30(144/4205)				

(Note1)[Unit: mm]

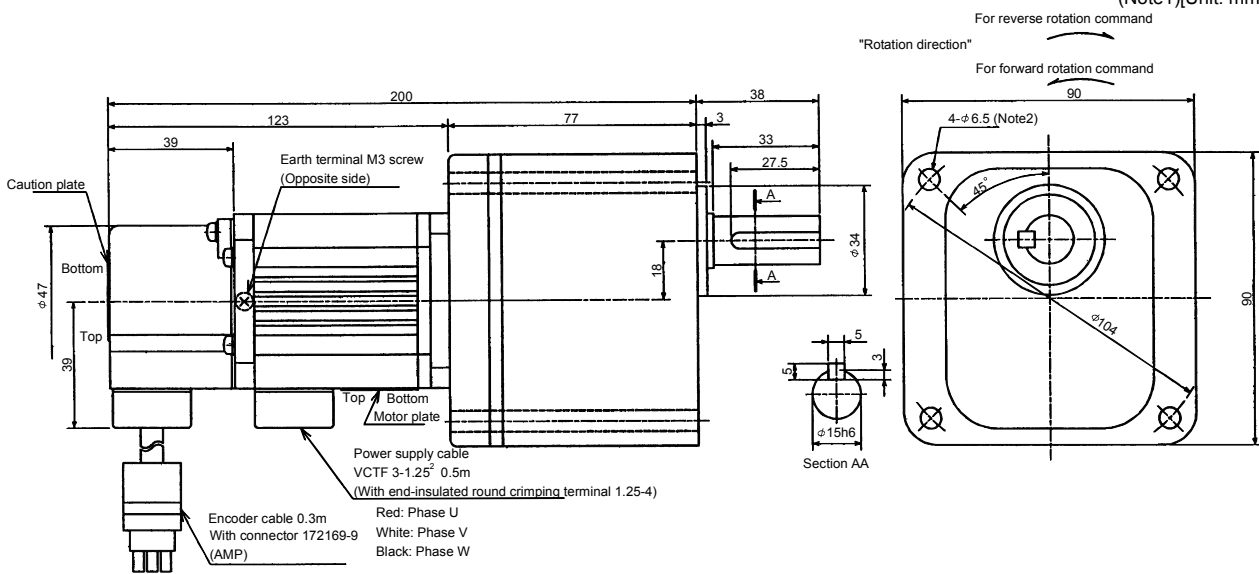

- Note: 1. The dimensions without tolerances are reference dimensions.
2. Four M6×90 through bolts are provided.

Z694765*

7. OUTLINE DIMENSION DRAWINGS

Model	Output [W]	Reduction Gear Model	Reduction Ratio (Actual Reduction Ratio)	Inertia Moment $J[\times 10^{-4} \text{ kg} \cdot \text{m}^2]$	Backlash	Mass [kg]	Output Shaft Rotation Direction
HA-FF23G1	200	GR-S-20	1/5(57/280)	0.373	40min. to 1.5°	5.0	Same as that of motor shaft
			1/10(39/400)				
			1/20(51/980)	0.37			
			1/30(1/30)				

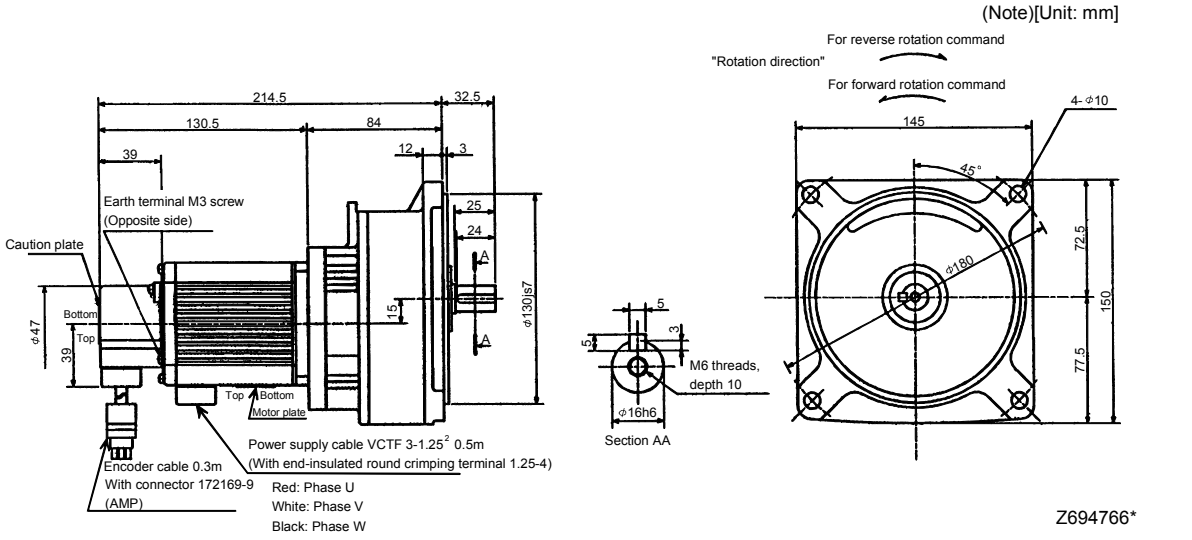

Model	Output [W]	Reduction Gear Model	Reduction Ratio (Actual Reduction Ratio)	Inertia Moment $J[\times 10^{-4} \text{ kg} \cdot \text{m}^2]$	Backlash	Mass [kg]	Output Shaft Rotation Direction
HA-FF33G1	300	GR-S-30	1/5(19/94)	0.545	40min. to 1.5°	6.5	Same as that of motor shaft
			1/10(39/376)				
			1/20(72/1363)	0.538			
			1/30(11/329)				

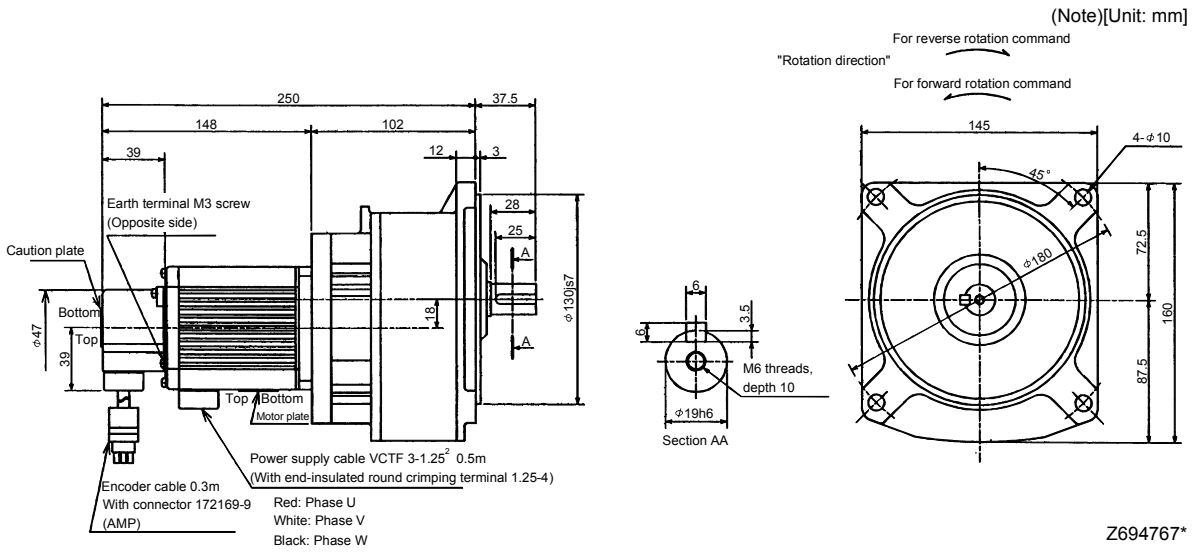

7. OUTLINE DIMENSION DRAWINGS

Model	Output [W]	Reduction Gear Model	Reduction Ratio (Actual Reduction Ratio)	Inertia Moment $J[\times 10^{-4} \text{ kg} \cdot \text{m}^2]$	Backlash	Mass [kg]	Output Shaft Rotation Direction
HA-FF43G1	400	GR-S-40	1/5(19/94)	1.02	40min. to 1.5°	8.0	Same as that of motor shaft
			1/10(39/376)				
			1/20(72/1363)	1.01			
			1/30(11/329)				

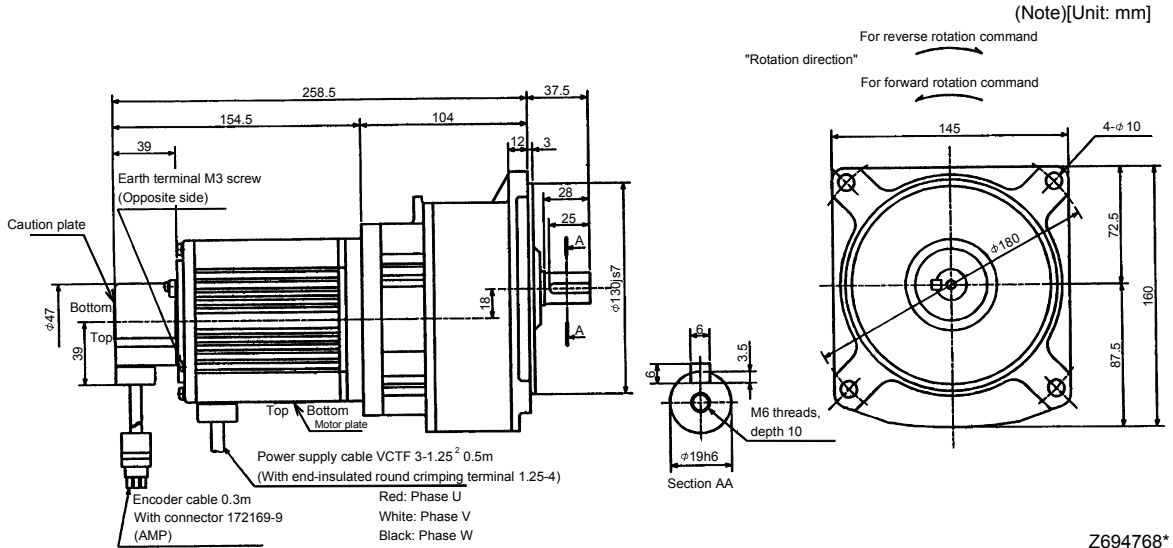

Note: The dimensions without tolerances are reference dimensions.

Model	Output [W]	Reduction Gear Model	Reduction Ratio (Actual Reduction Ratio)	Inertia Moment $J[\times 10^{-4} \text{ kg} \cdot \text{m}^2]$	Backlash	Mass [kg]	Output Shaft Rotation Direction
HA-FF63G1	600	GR-S-60	1/5(10/49)	1.34	40min. to 1.5°	13.0	Same as that of motor shaft
			1/10(243/2401)				
			1/20(153/2891)	1.32			
			1/30(27/784)				

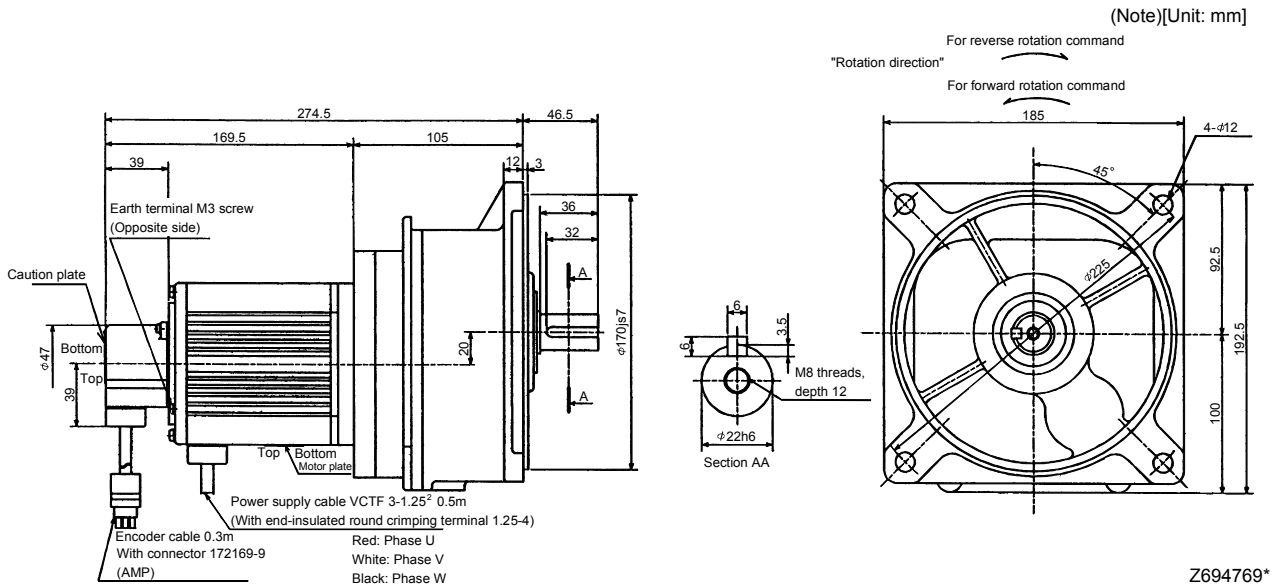

Note: The dimensions without tolerances are reference dimensions.

7. OUTLINE DIMENSION DRAWINGS

(b) With electromagnetic brake

Model	Output [W]	Brake static friction torque [N · m]	Reduction Gear Model	Reduction Ratio (Actual Reduction Ratio)	Inertia Moment $J[\times 10^{-4} \text{kg} \cdot \text{m}^2]$	Backlash	Mass [kg]	Output Shaft Rotation Direction
HA-FF053BG1	50	0.39	GR-S-10	1/5(9/44)	0.085	40min. to 1.5°	2.8	Same as that of motor shaft
				1/10(3/29)				
				1/20(99/1972)	0.080			Opposite to that of motor shaft
				1/30(144/4205)				

(Note1)[Unit: mm]

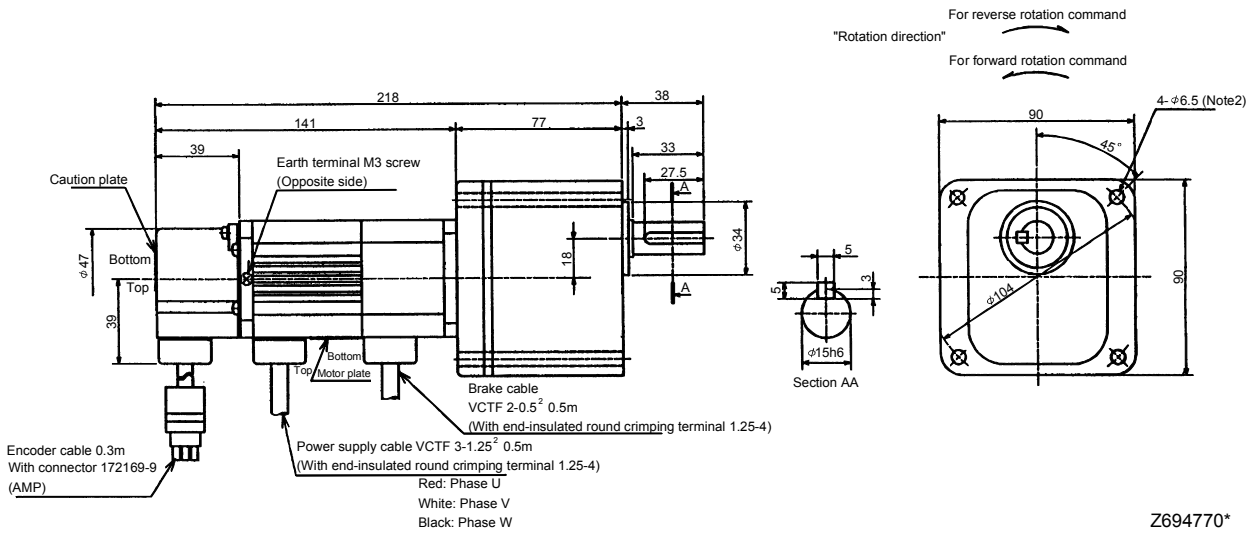

Note: 1. The dimensions without tolerances are reference dimensions.
2. Four M6×90 through bolts are provided.

Model	Output [W]	Brake static friction torque [N · m]	Reduction Gear Model	Reduction Ratio (Actual Reduction Ratio)	Inertia Moment $J[\times 10^{-4} \text{kg} \cdot \text{m}^2]$	Backlash	Mass [kg]	Output Shaft Rotation Direction
HA-FF13BG1	100	0.39	GR-S-10	1/5(9/44)	0.115	40min. to 1.5°	3.0	Same as that of motor shaft
				1/10(3/29)				
				1/20(99/1972)	0.11			Opposite to that of motor shaft
				1/30(144/4205)				

(Note1)[Unit: mm]

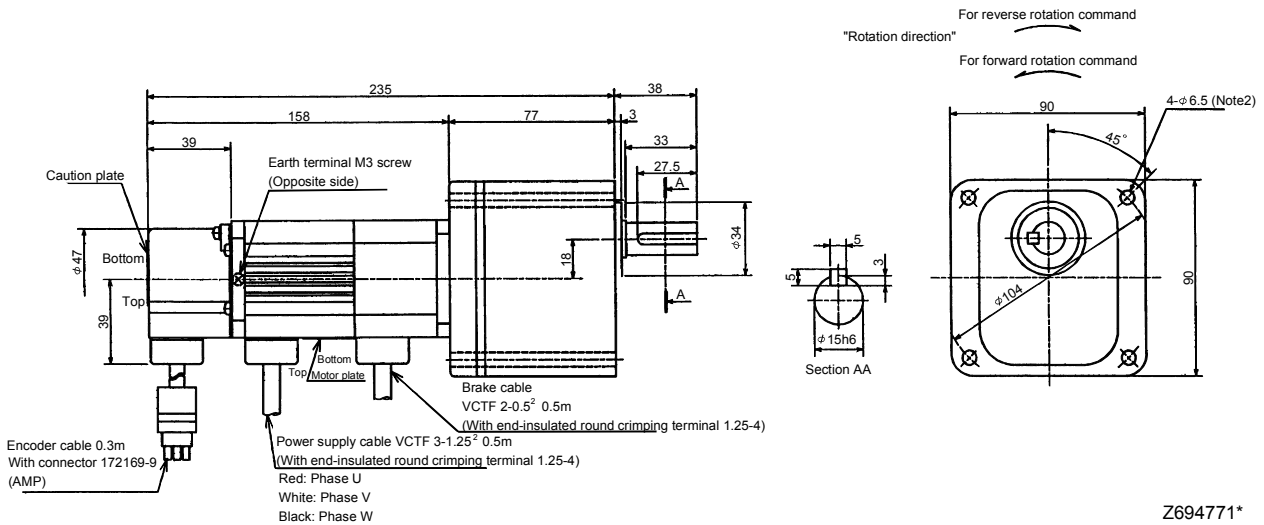

Note: 1. The dimensions without tolerances are reference dimensions.
2. Four M6×90 through bolts are provided.

7. OUTLINE DIMENSION DRAWINGS

Model	Output [W]	Brake static friction torque [N · m]	Reduction Gear Model	Reduction Ratio (Actual Reduction Ratio)	Inertia Moment $J[\times 10^{-4} \text{ kg} \cdot \text{m}^2]$	Backlash	Mass [kg]	Output Shaft Rotation Direction
HA-FF23BG1	200	1.20	GR-S-20	1/5(57/280)	0.503	40min. to 1.5°	5.6	Same as that of motor shaft
				1/10(39/400)				
				1/20(51/980)	0.500			
				1/30(1/30)				

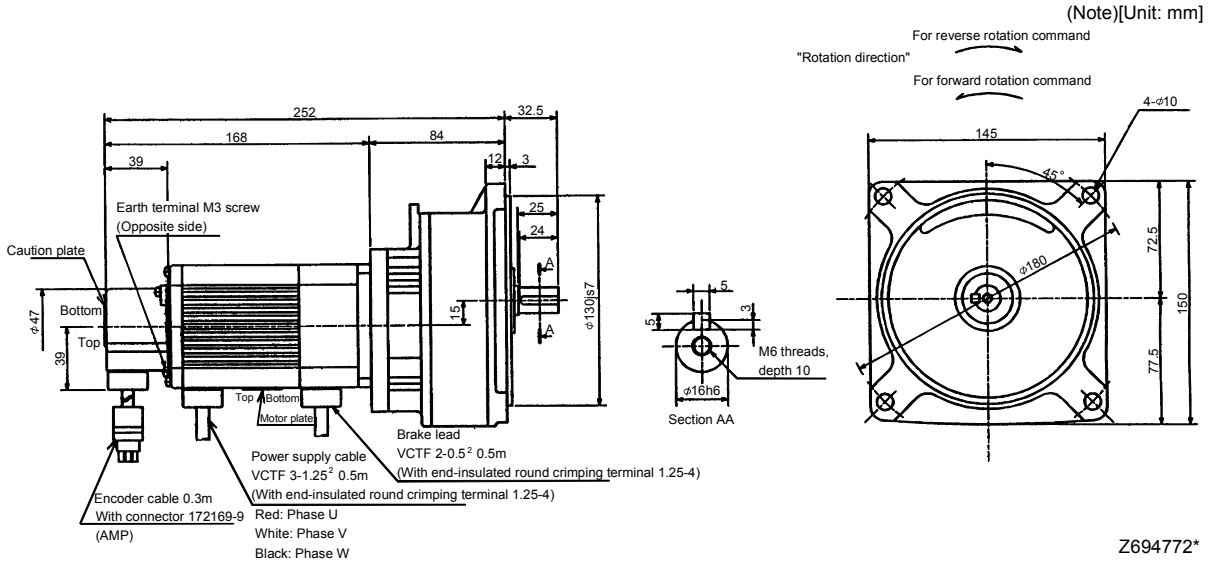

Note: The dimensions without tolerances are reference dimensions.

Model	Output [W]	Brake static friction torque [N · m]	Reduction Gear Model	Reduction Ratio (Actual Reduction Ratio)	Inertia Moment $J[\times 10^{-4} \text{ kg} \cdot \text{m}^2]$	Backlash	Mass [kg]	Output Shaft Rotation Direction
HA-FF33BG1	300	1.20	GR-S-30	1/5(19/94)	0.678	40min. to 1.5°	7.2	Same as that of motor shaft
				1/10(39/376)				
				1/20(72/1363)	0.670			
				1/30(11/329)				

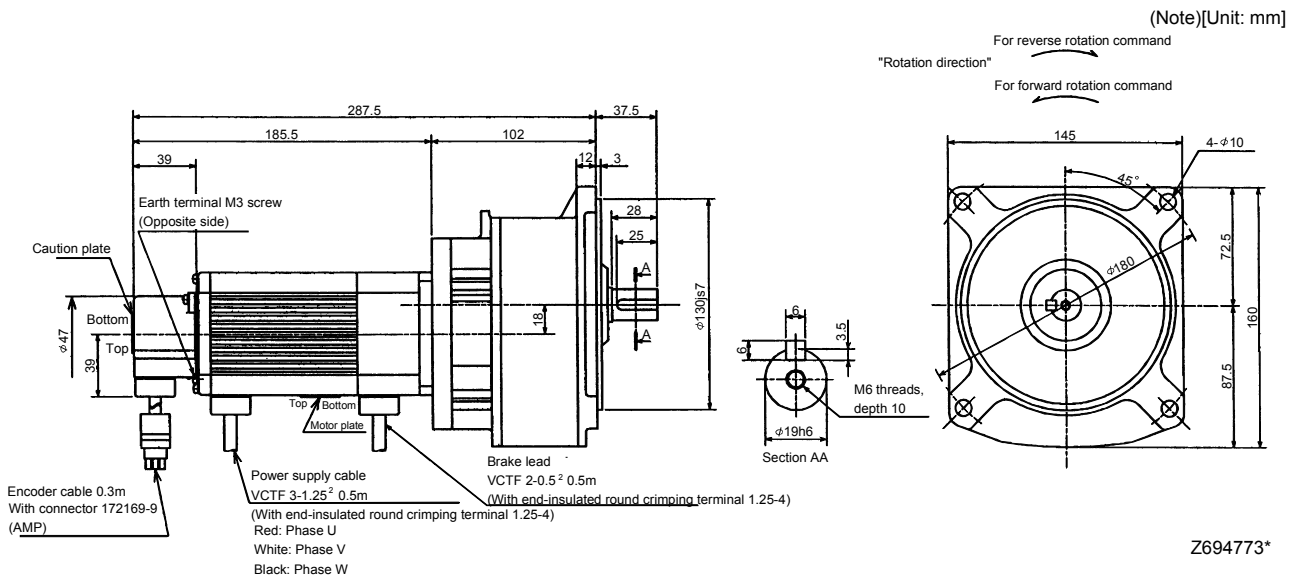

Note: The dimensions without tolerances are reference dimensions.

7. OUTLINE DIMENSION DRAWINGS

Model	Output [W]	Brake static friction torque [N · m]	Reduction Gear Model	Reduction Ratio (Actual Reduction Ratio)	Inertia Moment $J[\times 10^{-4} \text{ kg} \cdot \text{m}^2]$	Backlash	Mass [kg]	Output Shaft Rotation Direction
HA-FF43BG1	400	2.30	GR-S-40	1/5(19/94)	1.37	40min. to 1.5°	8.9	Same as that of motor shaft
				1/10(39/376)				
				1/20(72/1363)	1.36			
				1/30(11/329)				

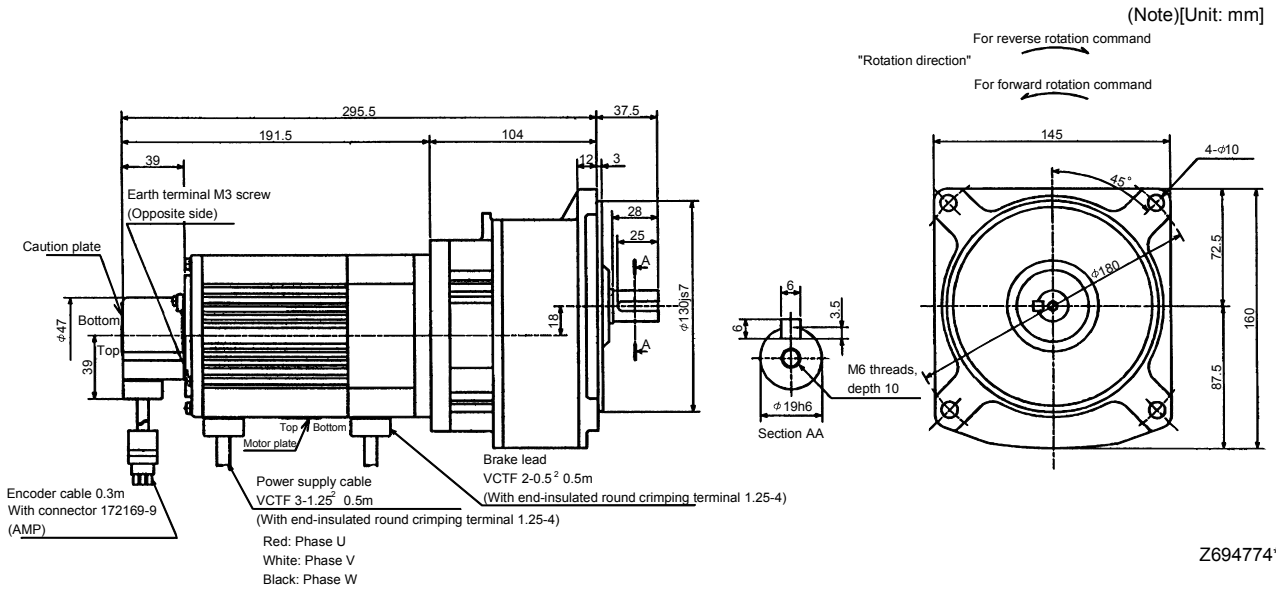

Note: The dimensions without tolerances are reference dimensions.

Model	Output [W]	Brake static friction torque [N · m]	Reduction Gear Model	Reduction Ratio (Actual Reduction Ratio)	Inertia Moment $J[\times 10^{-4} \text{ kg} \cdot \text{m}^2]$	Backlash	Mass [kg]	Output Shaft Rotation Direction
HA-FF63BG1	600	2.30	GR-S-60	1/5(10/49)	1.69	40min. to 1.5°	13.9	Same as that of motor shaft
				1/10(243/2401)				
				1/20(153/2891)	1.67			
				1/30(27/784)				

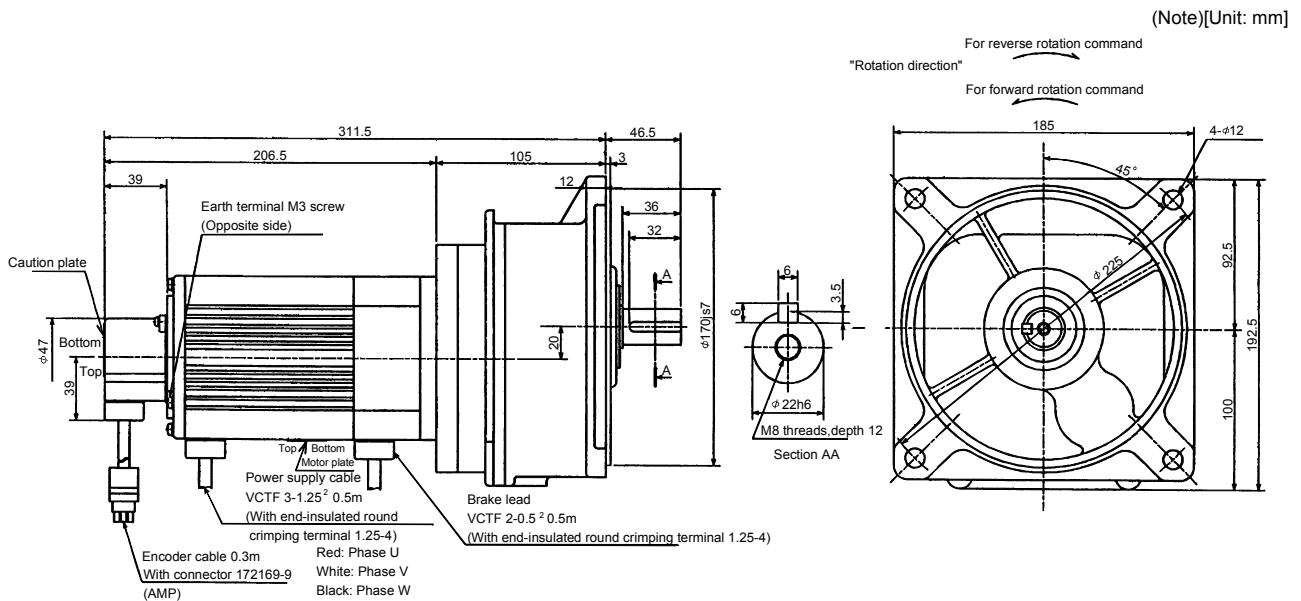

Note: The dimensions without tolerances are reference dimensions.

7. OUTLINE DIMENSION DRAWINGS

(4) With reduction gear for precision application

The outer frame of the reduction gear is a material surface such as casting. Its actual dimensions may be 1 to 3mm larger than the drawing dimensions. Design the machine side with allowances.

(a) Without electromagnetic brake

Model	Output [W]	Reduction Gear Model	Reduction Ratio	Inertia Moment $J[\times 10^{-4} \text{ kg} \cdot \text{m}^2]$	Backlash	Mass [kg]
HA-FF053G2	50	BM2-05B-A5MES	1/5	0.11	3 min. max.	2.3

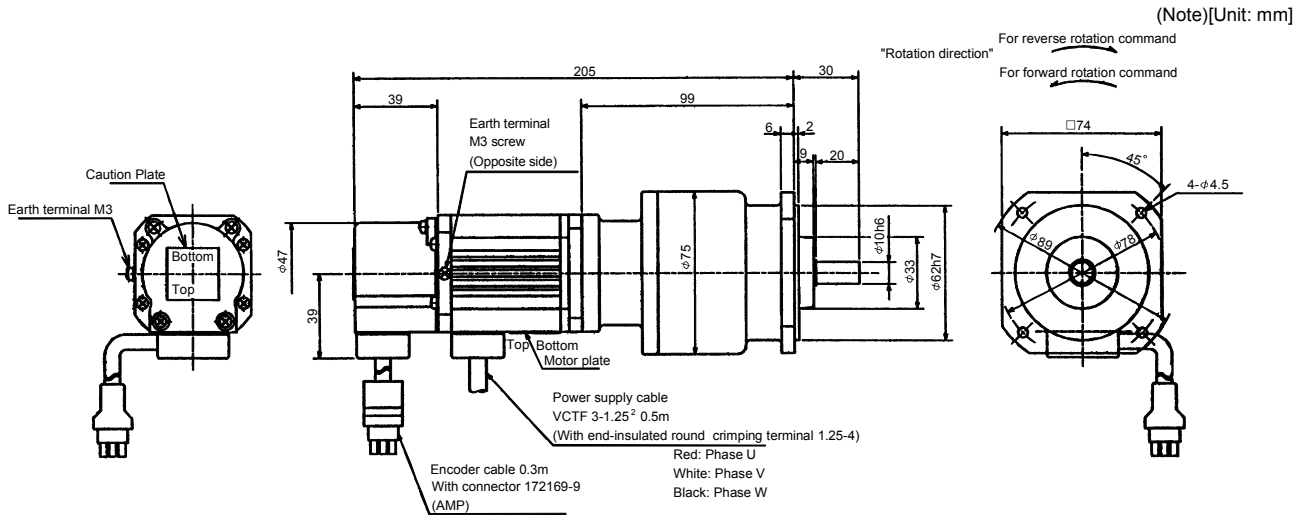

Note: The dimensions without tolerances are reference dimensions.

Z694850*

Model	Output [W]	Variable dimensions L	Reduction Gear Model	Reduction Ratio	Inertia Moment $J[\times 10^{-4} \text{ kg} \cdot \text{m}^2]$	Backlash	Mass [kg]
HA-FF053G2	50	205	BM2-10B-A5MES	1/10	0.108	3 min. max.	2.3
HA-FF053G2	50	205	BM2-15B-A5MES	1/15	0.105	3 min. max.	2.3
HA-FF13G2	100	205	BM2-05B-01MES	1/5	0.143	3 min. max.	2.5

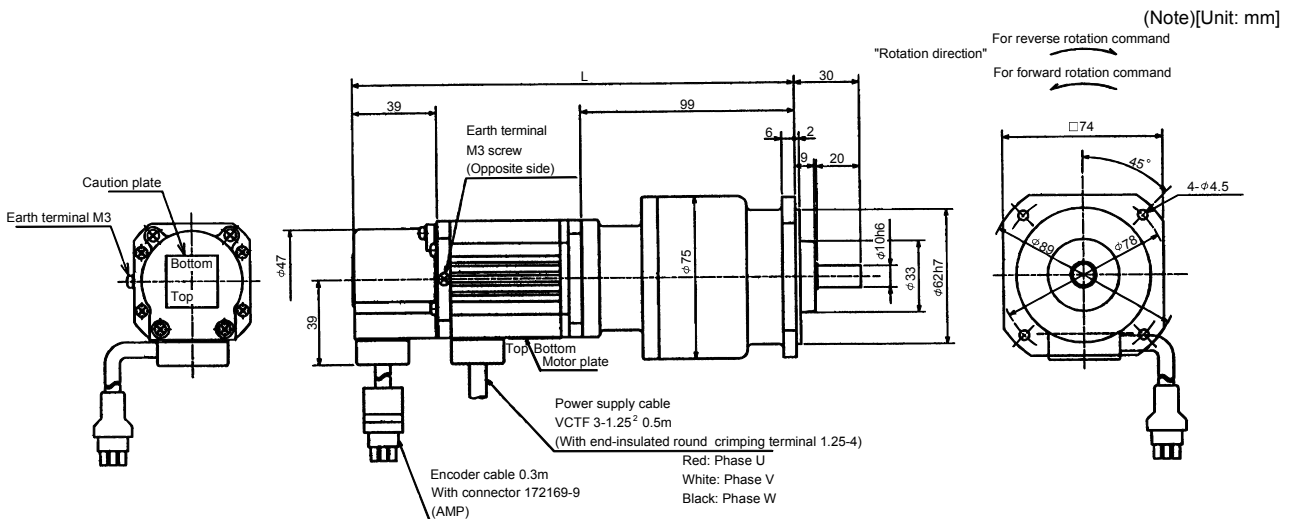

Note: The dimensions without tolerances are reference dimensions.

Z694805*

7. OUTLINE DIMENSION DRAWINGS

Model	Output [W]	Variable dimensions L	Reduction Gear Model	Reduction Ratio	Inertia Moment $J[\times 10^{-4} \text{kg} \cdot \text{m}^2]$	Backlash	Mass [kg]
HA-FF053G2	50	213	BM3-25B-A5MES	1/25	0.110	3min. max.	2.8
HA-FF13G2	100	230	BM3-10B-01MES	1/10	0.165	3min. max.	3.0
HA-FF13G2	100	230	BM3-15B-01MES	1/15	0.155	3min. max.	3.0

(Note)[Unit: mm]

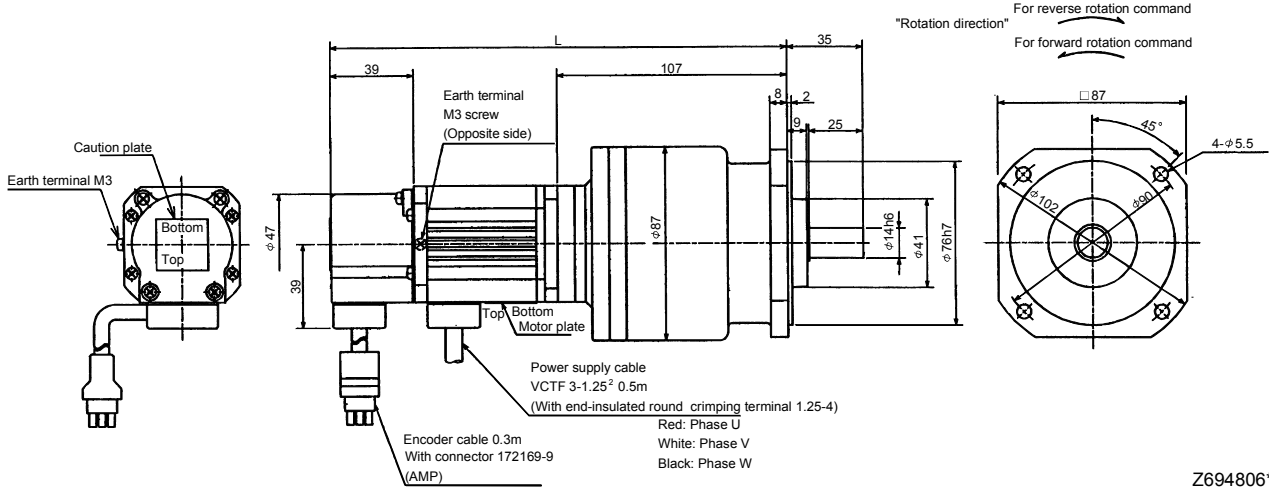

Z694806*

Note: The dimensions without tolerances are reference dimensions.

Model	Output [W]	Reduction Gear Model	Reduction Ratio	Inertia Moment $J[\times 10^{-4} \text{kg} \cdot \text{m}^2]$	Backlash	Mass [kg]
HA-FF13G2	100	BM4-25B-01MES	1/25	0.29	3min. max.	5.0

(Note)[Unit: mm]

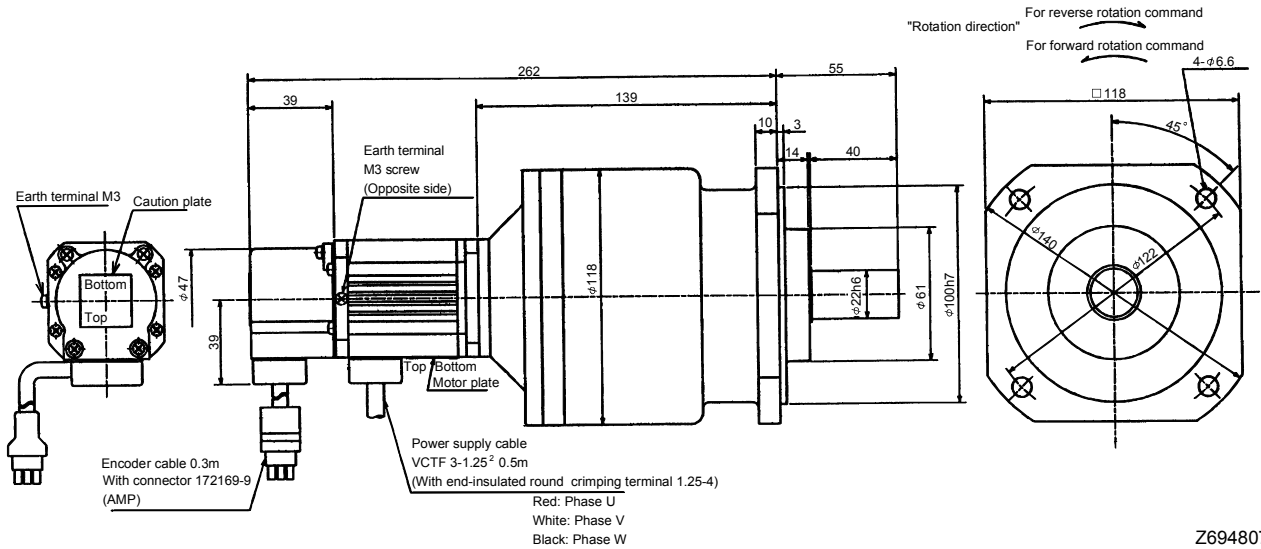

Z694807*

Note: The dimensions without tolerances are reference dimensions.

7. OUTLINE DIMENSION DRAWINGS

Model	Output [W]	Reduction Gear Model	Reduction Ratio	Inertia Moment $J[\times 10^{-4} \text{kg} \cdot \text{m}^2]$	Backlash	Mass [kg]
HA-FF13G2	100	BL1-45B-01MES	1/45	0.293	3min. max.	6.0

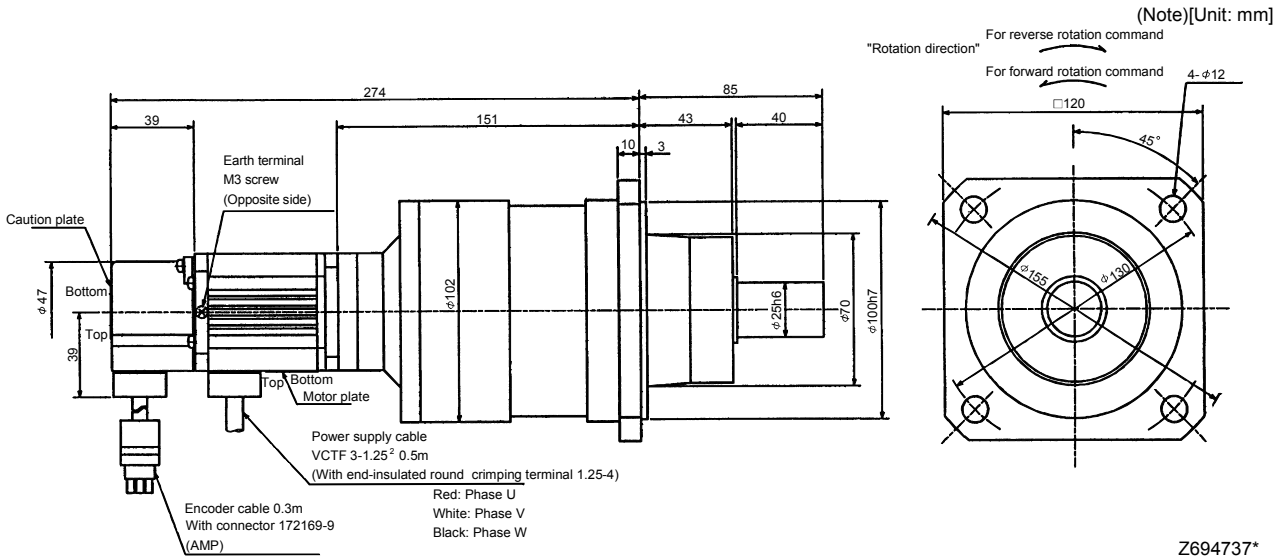

Note: The dimensions without tolerances are reference dimensions.

Model	Output [W]	Reduction Gear Model	Reduction Ratio	Inertia Moment $J[\times 10^{-4} \text{kg} \cdot \text{m}^2]$	Backlash	Mass [kg]
HA-FF23G2	200	BM3-05B-02MES	1/5	0.425	3min. max.	3.8

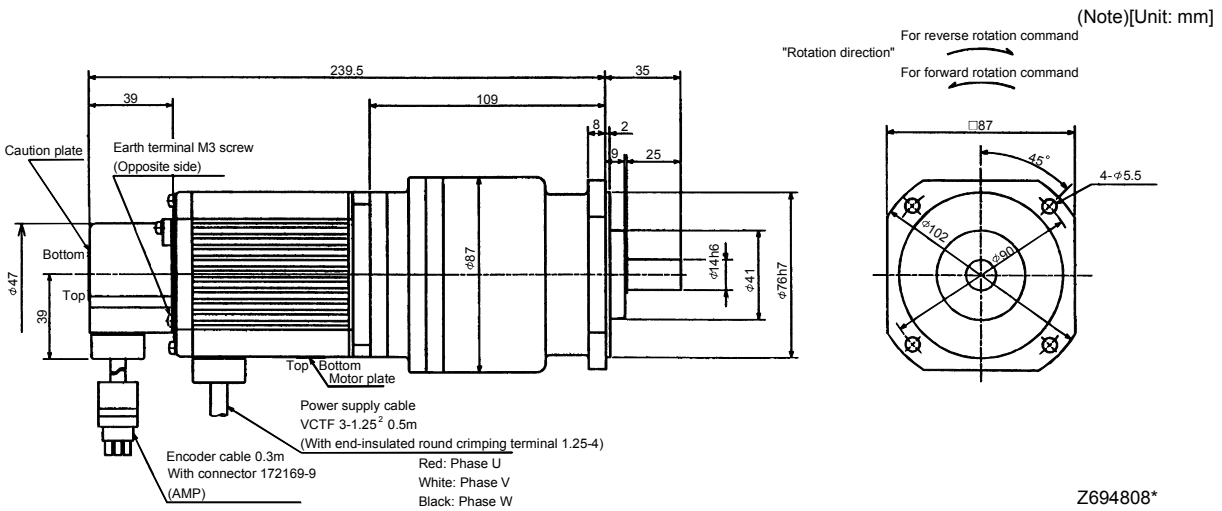

Note: The dimensions without tolerances are reference dimensions.

7. OUTLINE DIMENSION DRAWINGS

Model	Output [W]	Variable dimensions L	Reduction Gear Model	Reduction Ratio	Inertia Moment $J[\times 10^{-4} \text{ kg} \cdot \text{m}^2]$	Backlash	Mass [kg]
HA-FF23G2	200	269.5	BM4-10B-02MES	1/10	0.645	3min. max.	5.8
HA-FF23G2	200	269.5	BM4-15B-02MES	1/15	0.618	3min. max.	5.8
HA-FF33G2	300	287	BM4-10B-03MES	1/10	0.795	3min. max.	6.1

(Note)[Unit: mm]

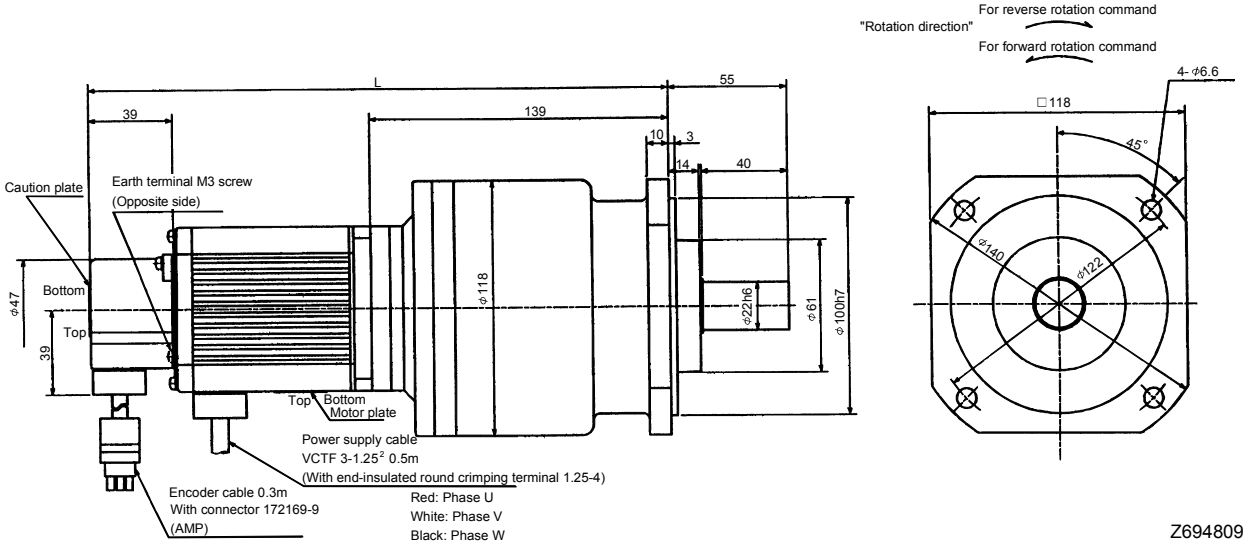

Note: The dimensions without tolerances are reference dimensions.

Model	Output [W]	Variable dimensions L	Reduction Gear Model	Reduction Ratio	Inertia Moment $J[\times 10^{-4} \text{ kg} \cdot \text{m}^2]$	Backlash	Mass [kg]
HA-FF23G2	200	278	BL1-20B-02MES	1/20	0.730	3min. max.	6.8
HA-FF23G2	200	278	BL1-29B-02MES	1/29	0.633	3min. max.	6.8
HA-FF33G2	300	295	BL1-20B-03MES	1/20	0.880	3min. max.	7.1

(Note)[Unit: mm]

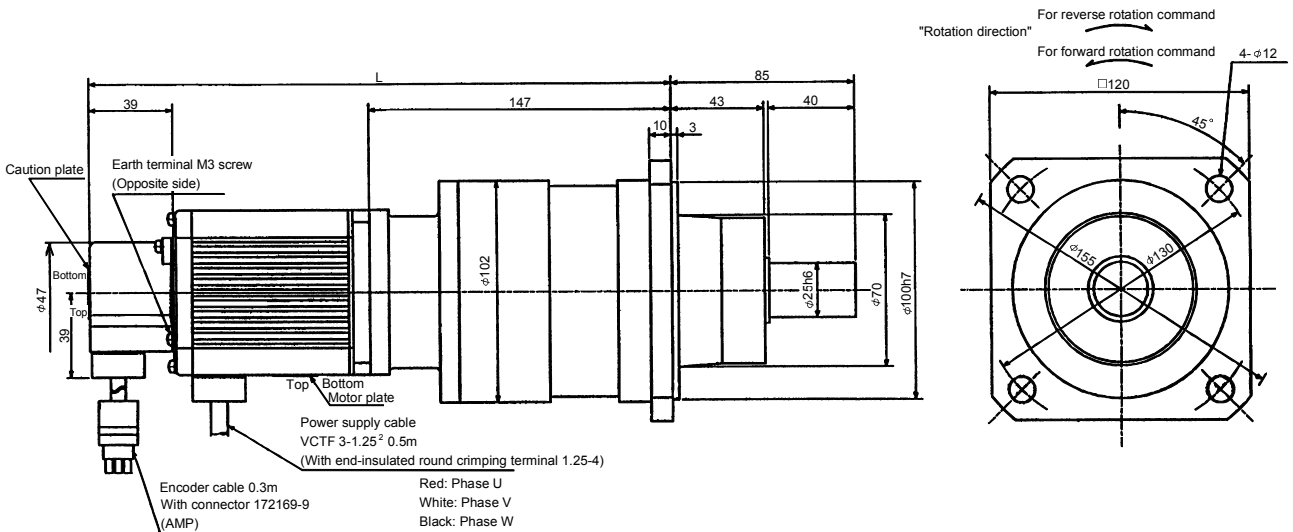

Note: The dimensions without tolerances are reference dimensions.

7. OUTLINE DIMENSION DRAWINGS

Model	Output [W]	Variable dimensions L	Reduction Gear Model	Reduction Ratio	Inertia Moment $J[\times 10^{-4} \text{ kg} \cdot \text{m}^2]$	Backlash	Mass [kg]
HA-FF23G2	200	299	BL2-45B-02MES	1/45	0.763	3min. max.	12.3
HA-FF33G2	300	316	BL2-29B-03MES	1/29	1.535	3min. max.	12.6
HA-FF33G2	300	316	BL2-45B-03MES	1/45	0.913	3min. max.	12.6

(Note)[Unit: mm]

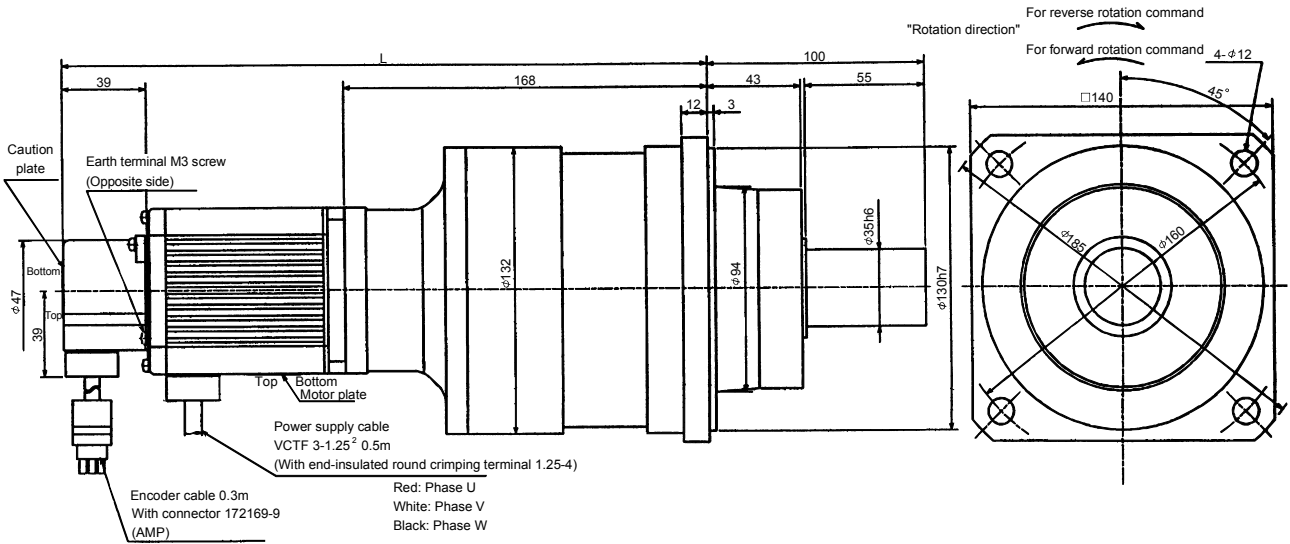

Note: The dimensions without tolerances are reference dimensions.

Z694739*

Model	Output [W]	Reduction Gear Model	Reduction Ratio	Inertia Moment $J[\times 10^{-4} \text{ kg} \cdot \text{m}^2]$	Backlash	Mass [kg]
HA-FF33G2	300	BM4-05B-03MES	1/5	0.818	3min. max.	6.1

(Note)[Unit: mm]

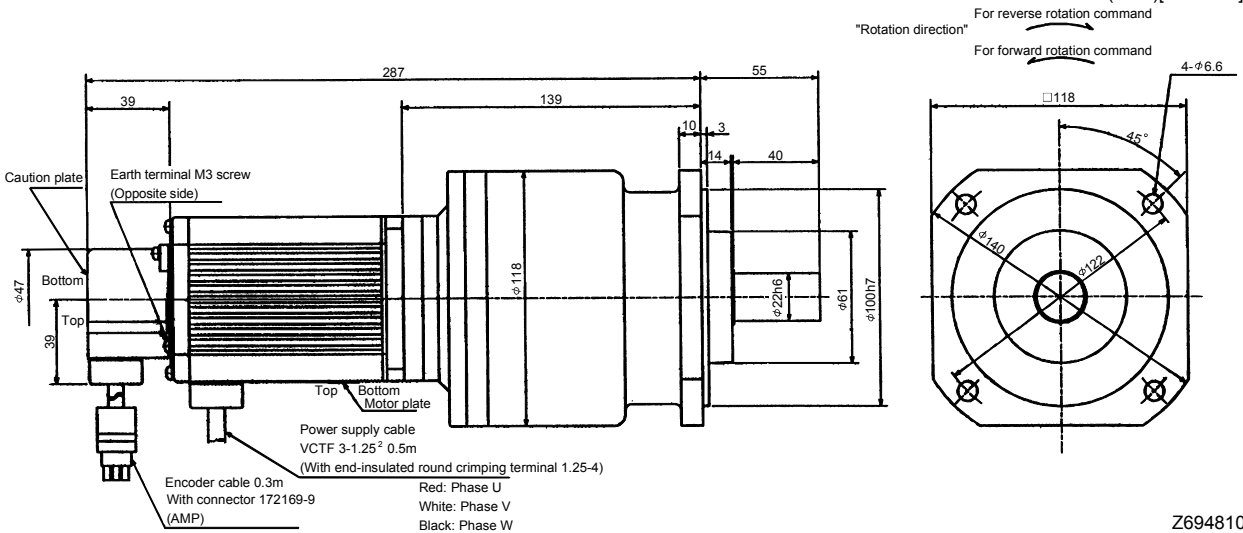

Note: The dimensions without tolerances are reference dimensions.

Z694810*

7. OUTLINE DIMENSION DRAWINGS

Model	Output [W]	Reduction Gear Model	Reduction Ratio	Inertia Moment $J[\times 10^{-4} \text{ kg} \cdot \text{m}^2]$	Backlash	Mass [kg]
HA-FF43G2	400	BM4-05B-04MES	1/5	1.293	3min. max.	7.7

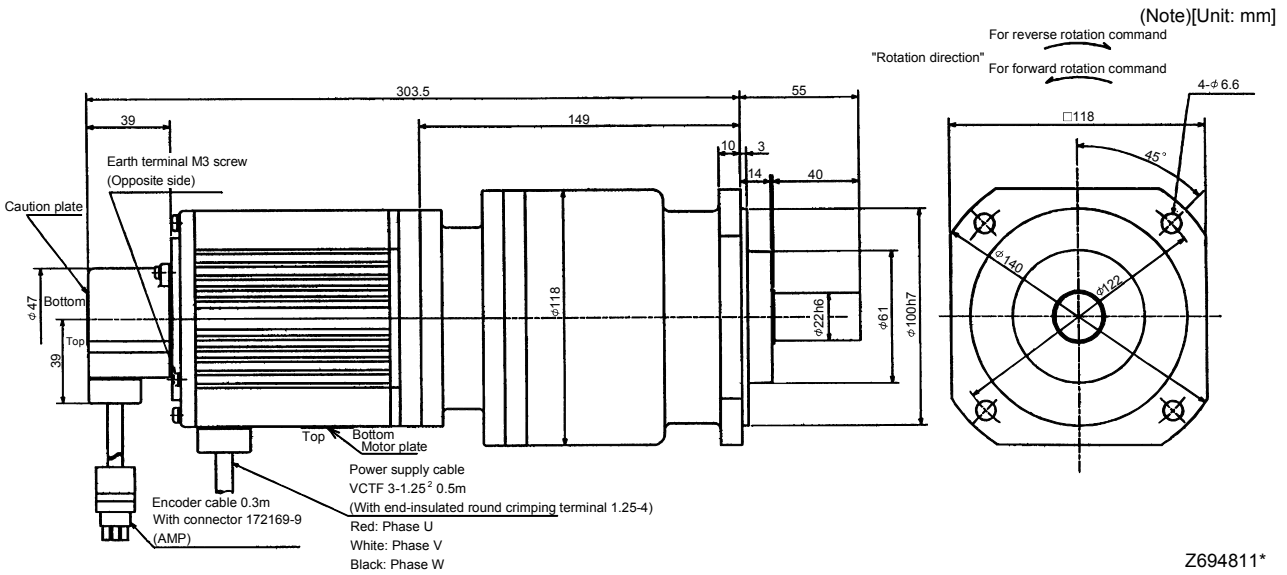

Note: The dimensions without tolerances are reference dimensions.

Model	Output [W]	Variable Dimensions		Reduction Gear Model	Reduction Ratio	Inertia Moment $J[\times 10^{-4} \text{ kg} \cdot \text{m}^2]$	Backlash	Mass [kg]
		L	H					
HA-FF43G2	400	295.5	141	BL1-09B-04MES	1/9	1.193	3min. max.	8.2
HA-FF63G2	600	300.5	131	BL1-05B-06MES	1/5	1.283	3min. max.	8.8
HA-FF63G2	600	310.5	141	BL1-09B-06MES	1/9	1.418	3min. max.	8.8

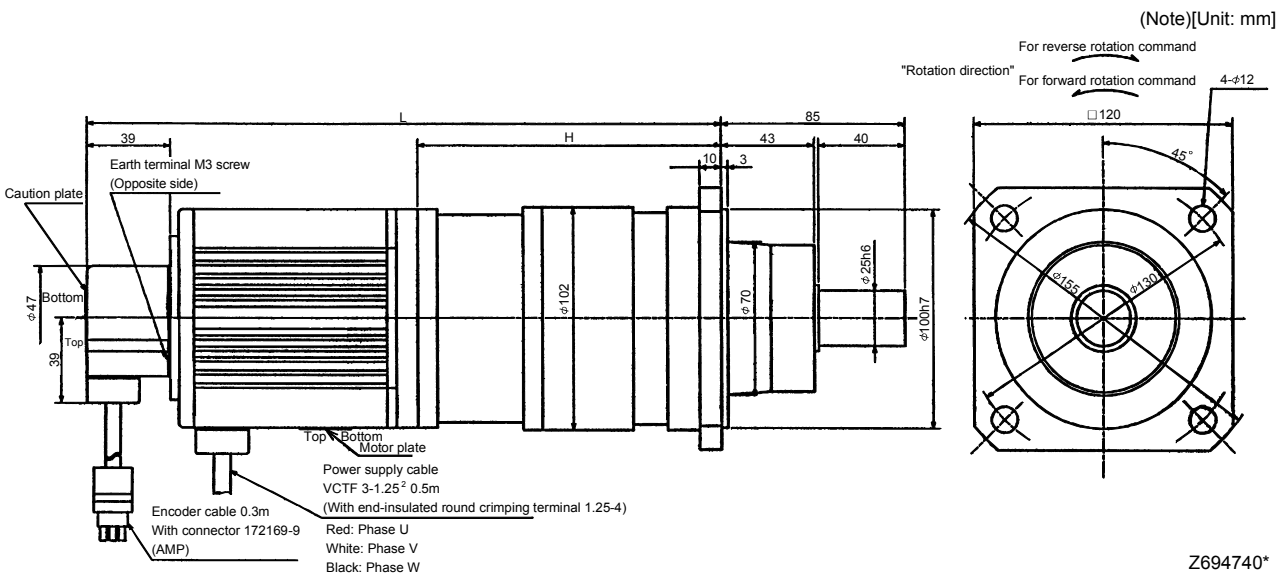

Note: The dimensions without tolerances are reference dimensions.

7. OUTLINE DIMENSION DRAWINGS

Model	Output [W]	Variable Dimensions		Reduction Gear Model	Reduction Ratio	Inertia Moment $J[\times 10^{-4} \text{kg} \cdot \text{m}^2]$	Backlash	Mass [kg]
		L	H					
HA-FF43G2	400	323.5	169	BL2-20B-04MES	1/20	2.378	3min. max	14.2
HA-FF43G2	400	323.5	169	BL2-29B-04MES	1/29	2.010	3min. max	14.2
HA-FF43G2	400	333.5	179	BL2-45B-04MES	1/45	1.388	3min. max	14.2
HA-FF63G2	600	338.5	169	BL2-20B-06MES	1/20	2.603	3min. max	14.8
HA-FF63G2	600	338.5	169	BL2-29B-06MES	1/29	2.235	3min. max	14.8

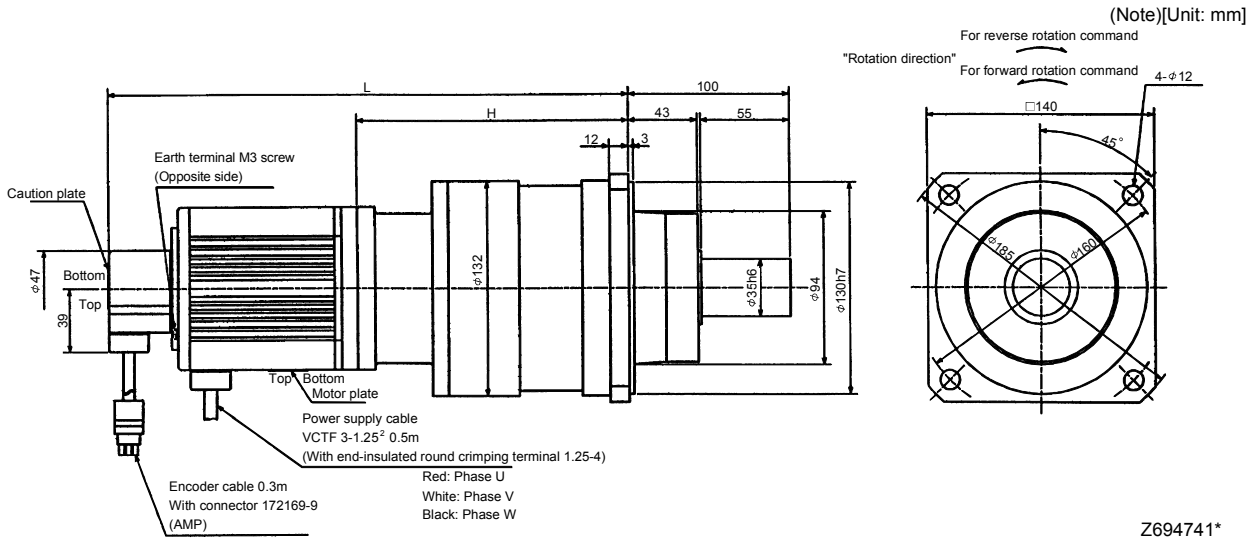

Note: The dimensions without tolerances are reference dimensions.

Model	Output [W]	Reduction Gear Model	Reduction Ratio	Inertia Moment $J[\times 10^{-4} \text{kg} \cdot \text{m}^2]$	Backlash	Mass [kg]
HA-FF63G2	600	BL3-45B-06MES	1/45	3.13	3min. max.	29.8

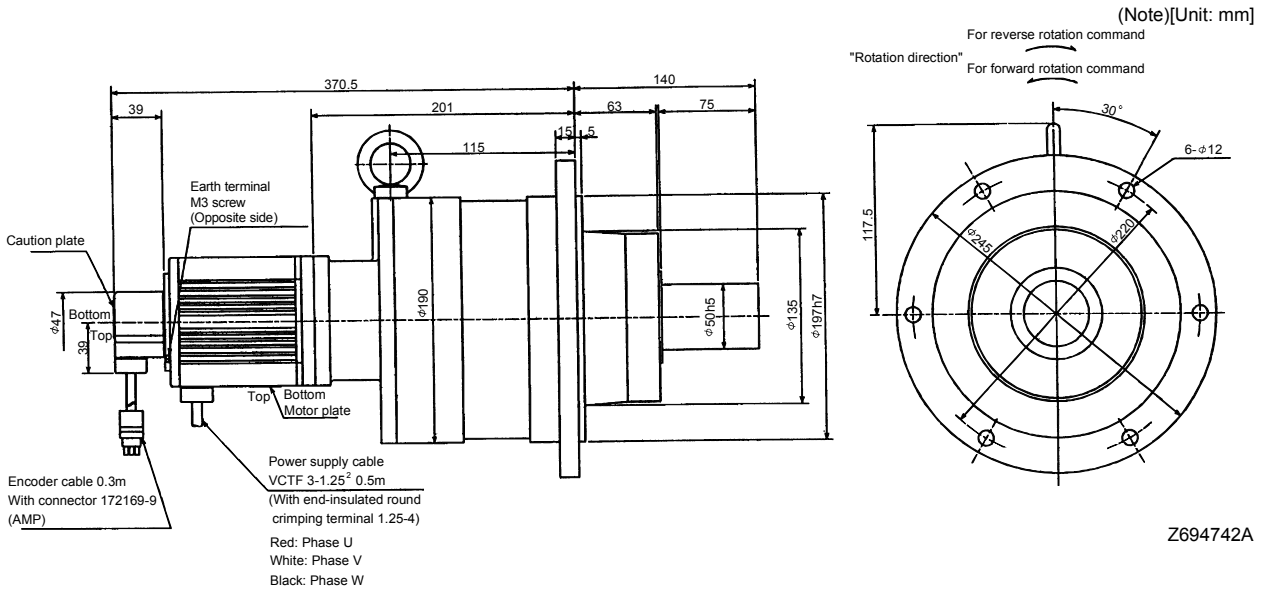

Note: The dimensions without tolerances are reference dimensions.

7. OUTLINE DIMENSION DRAWINGS

(b) With electromagnetic brake

Model	Output [W]	Brake static friction torque [N · m]	Reduction Gear Model	Reduction Ratio	Inertia Moment $J[\times 10^{-4} \text{ kg} \cdot \text{m}^2]$	Backlash	Mass [kg]
HA-FF053BG2	50	0.39	BM2-05B-A5MES	1/5	0.128	3min. max.	2.6

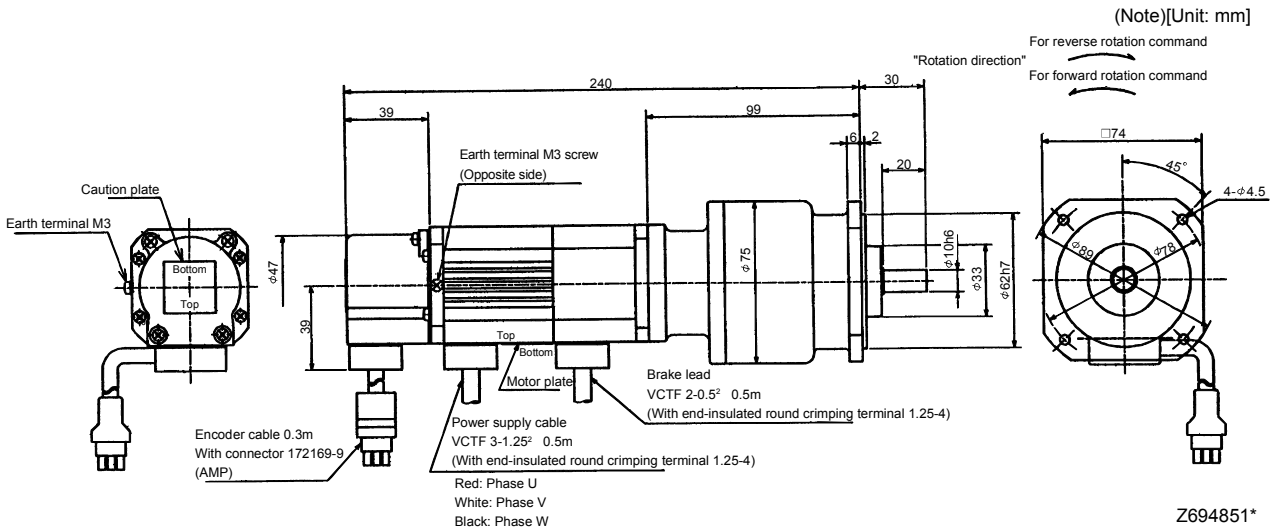

Note: The dimensions without tolerances are reference dimensions.

Model	Output [W]	Variable dimensions L	Brake static friction torque [N · m]	Reduction Gear Model	Reduction Ratio	Inertia Moment $J[\times 10^{-4} \text{ kg} \cdot \text{m}^2]$	Backlash	Mass [kg]
HA-FF053BG2	50	240	0.39	BM2-05B-A5MES	1/10	0.125	3 min. max.	2.6
HA-FF053BG2	50	240	0.39	BM2-15B-A5MES	1/15	0.123	3 min. max.	2.6
HA-FF13BG2	100	257	0.39	BM2-05B-01MES	1/5	0.160	3 min. max.	2.8

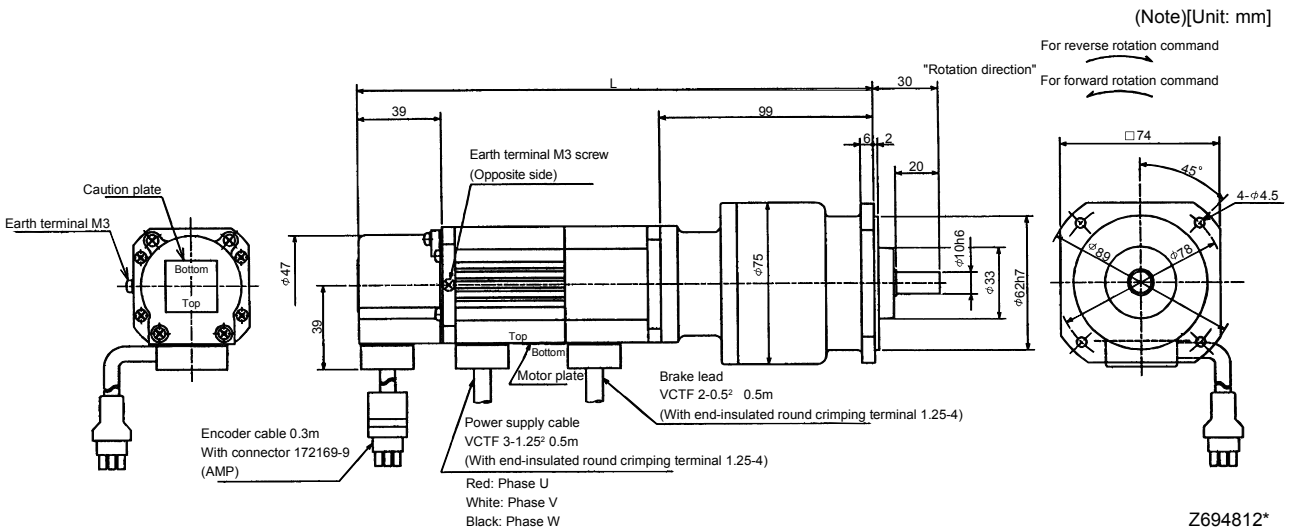

Note: The dimensions without tolerances are reference dimensions.

7. OUTLINE DIMENSION DRAWINGS

Model	Output [W]	Variable dimensions L	Brake static friction torque [N · m]	Reduction Gear Model	Reduction Ratio	Inertia Moment $J[\times 10^{-4} \text{ kg} \cdot \text{m}^2]$	Backlash	Mass [kg]
HA-FF053BG2	50	248	0.39	BM3-25B-A5MES	1/25	0.120	3 min. max.	3.2
HA-FF13BG2	100	265	0.39	BM3-10B-01MES	1/10	0.183	3 min. max.	3.4
HA-FF13BG2	100	265	0.39	BM3-15B-01MES	1/15	0.173	3 min. max.	3.4

(Note)[Unit: mm]

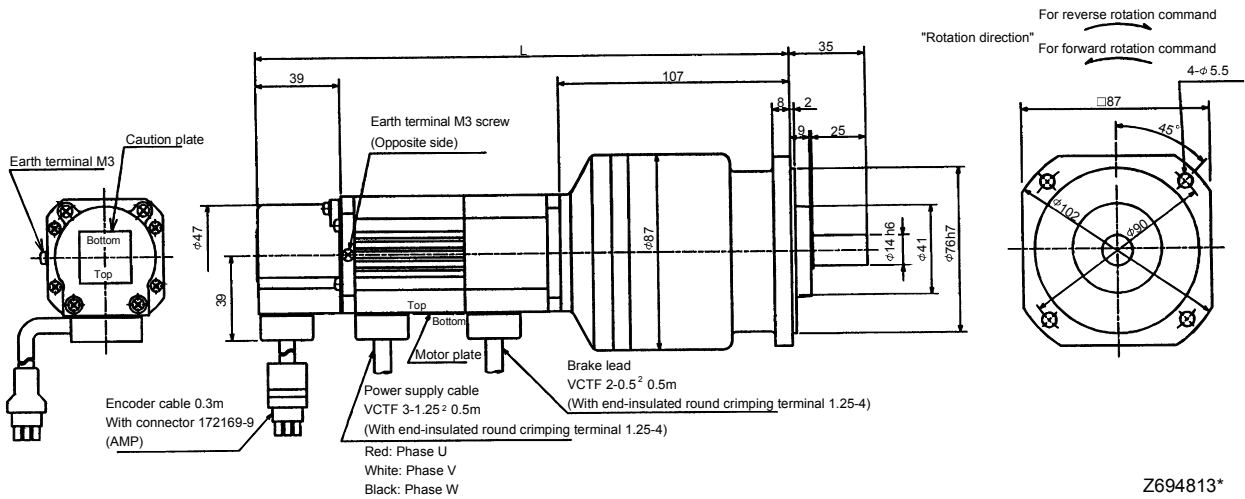

Note: The dimensions without tolerances are reference dimensions.

Model	Output [W]	Brake static friction torque [N · m]	Reduction Gear Model	Reduction Ratio	Inertia Moment $J[\times 10^{-4} \text{ kg} \cdot \text{m}^2]$	Backlash	Mass [kg]
HA-FF13BG2	100	0.39	BM4-25B-01MES	1/25	0.308	3 min. max.	5.3

(Note)[Unit: mm]

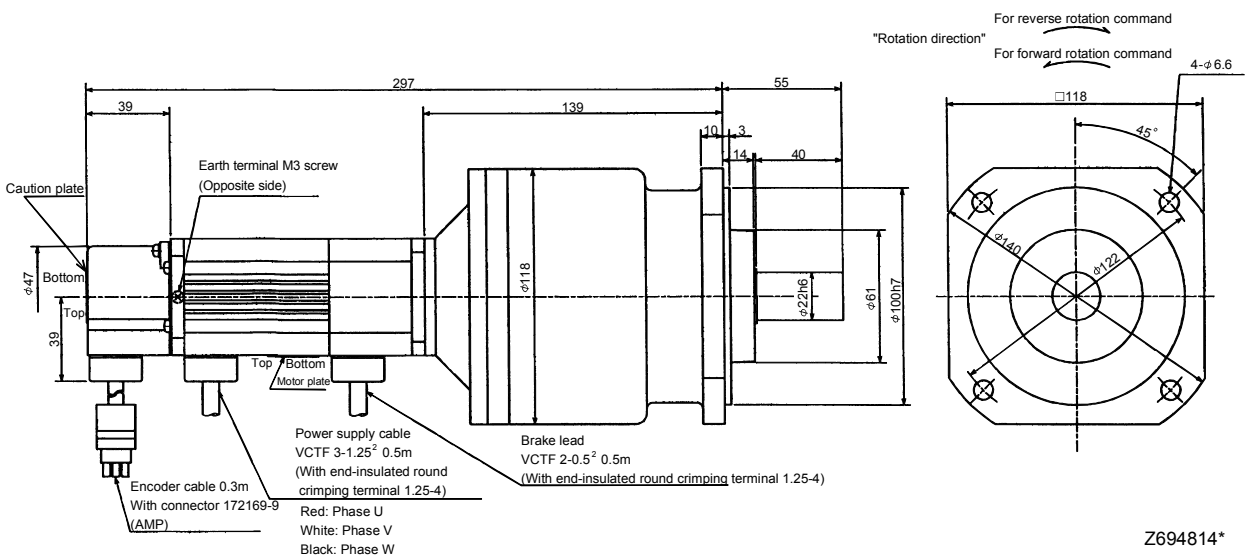

Note: The dimensions without tolerances are reference dimensions.

7. OUTLINE DIMENSION DRAWINGS

Model	Output [W]	Brake static friction torque [N · m]	Reduction Gear Model	Reduction Ratio	Inertia Moment $J[\times 10^{-4} \text{kg} \cdot \text{m}^2]$	Backlash	Mass [kg]
HA-FF13BG2	100	0.39	BL1-45B-01MES	1/45	0.298	3 min. max.	6.3

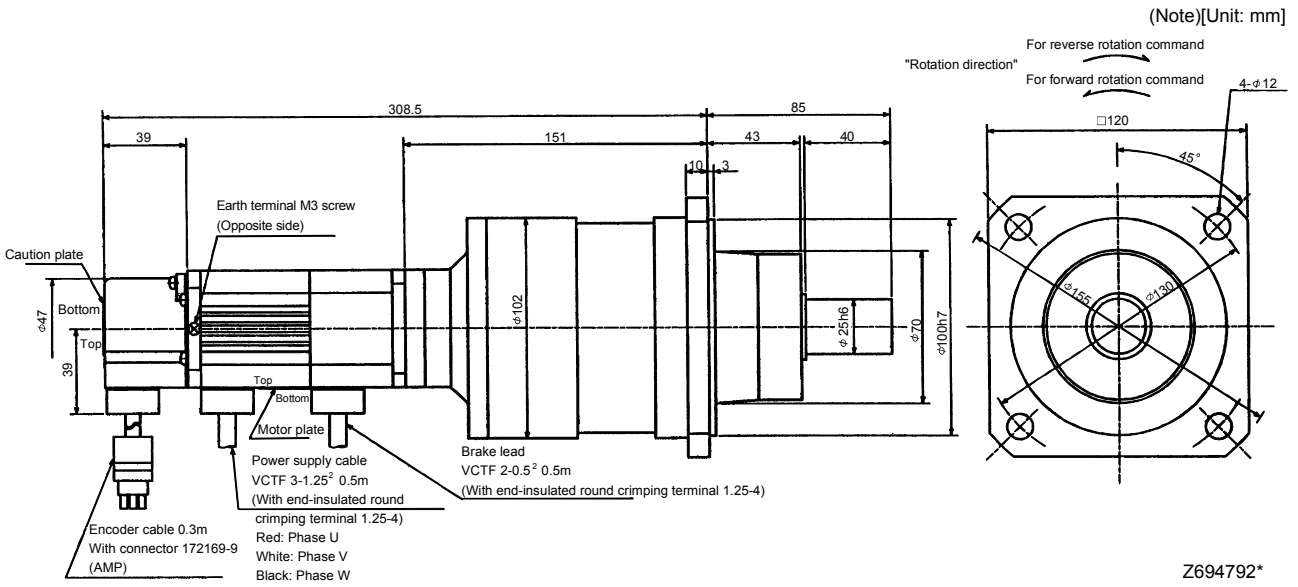

Note: The dimensions without tolerances are reference dimensions.

Model	Output [W]	Brake static friction torque [N · m]	Reduction Gear Model	Reduction Ratio	Inertia Moment $J[\times 10^{-4} \text{kg} \cdot \text{m}^2]$	Backlash	Mass [kg]
HA-FF23BG2	200	1.2	BM3-05B-02MES	1/5	0.558	3 min. max.	4.4

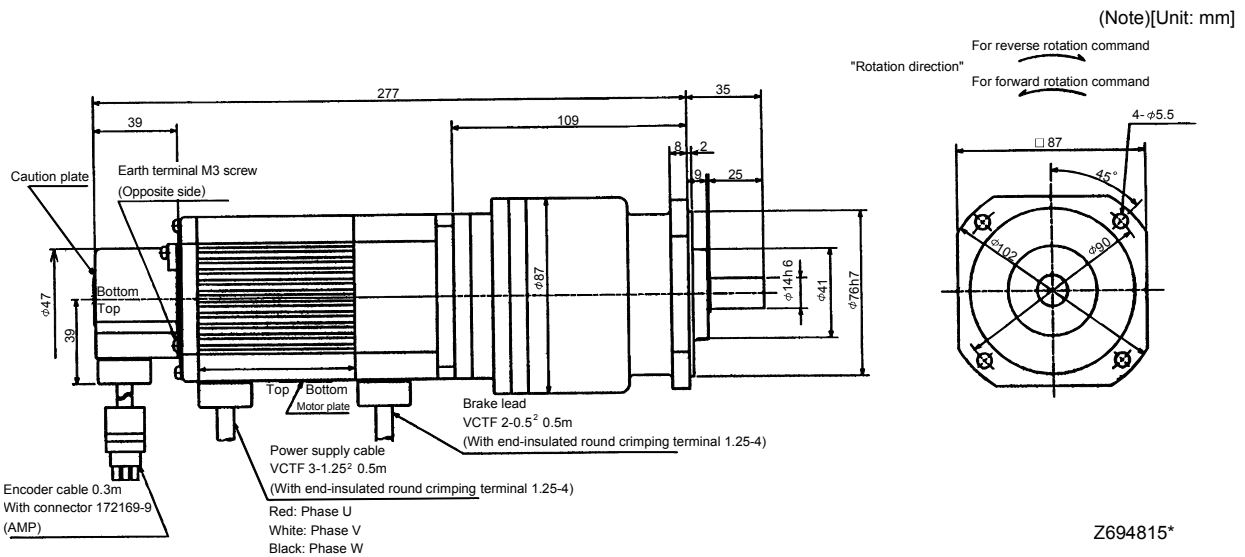

Note: The dimensions without tolerances are reference dimensions.

7. OUTLINE DIMENSION DRAWINGS

Model	Output [W]	Variable dimensions L	Brake static friction torque [N · m]	Reduction Gear Model	Reduction Ratio	Inertia Moment J [$\times 10^{-4}$ kg · m ²]	Backlash	Mass [kg]
HA-FF23BG2	200	307	1.2	BM4-10B-02MES	1/10	0.778	3 min. max.	6.4
HA-FF23BG2	200	307	1.2	BM4-15B-02MES	1/15	0.75	3 min. max.	6.4
HA-FF33BG2	300	324.5	1.2	BM4-10B-03MES	1/10	0.928	3 min. max.	6.7

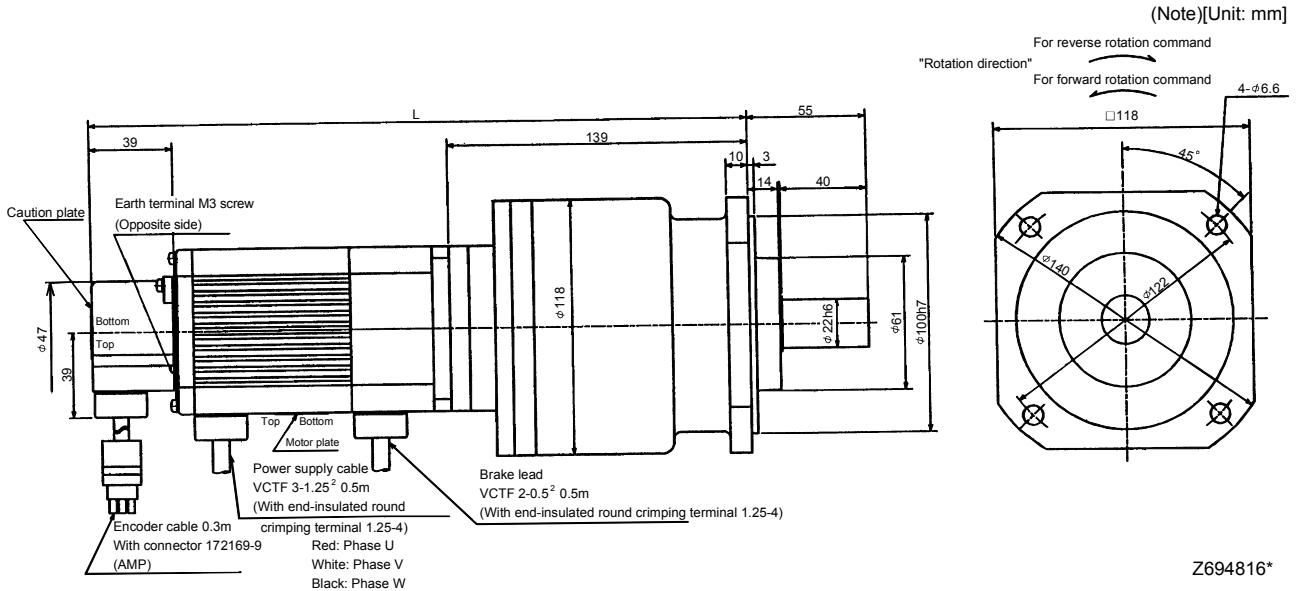

Note: The dimensions without tolerances are reference dimensions.

Model	Output [W]	Variable dimensions		Brake static friction torque [N · m]	Reduction Gear Model	Reduction Ratio	Inertia Moment J [$\times 10^{-4}$ kg · m ²]	Backlash	Mass [kg]
		L	H						
HA-FF23BG2	200	311.5	144	1.2	BL1-20B-02MES	1/20	0.885	3 min. max.	7.4
HA-FF23BG2	200	314.5	147	1.2	BL1-29B-02MES	1/29	0.765	3 min. max.	7.4
HA-FF33BG2	300	329.5	144	1.2	BL1-20B-03MES	1/20	1.013	3 min. max.	7.7

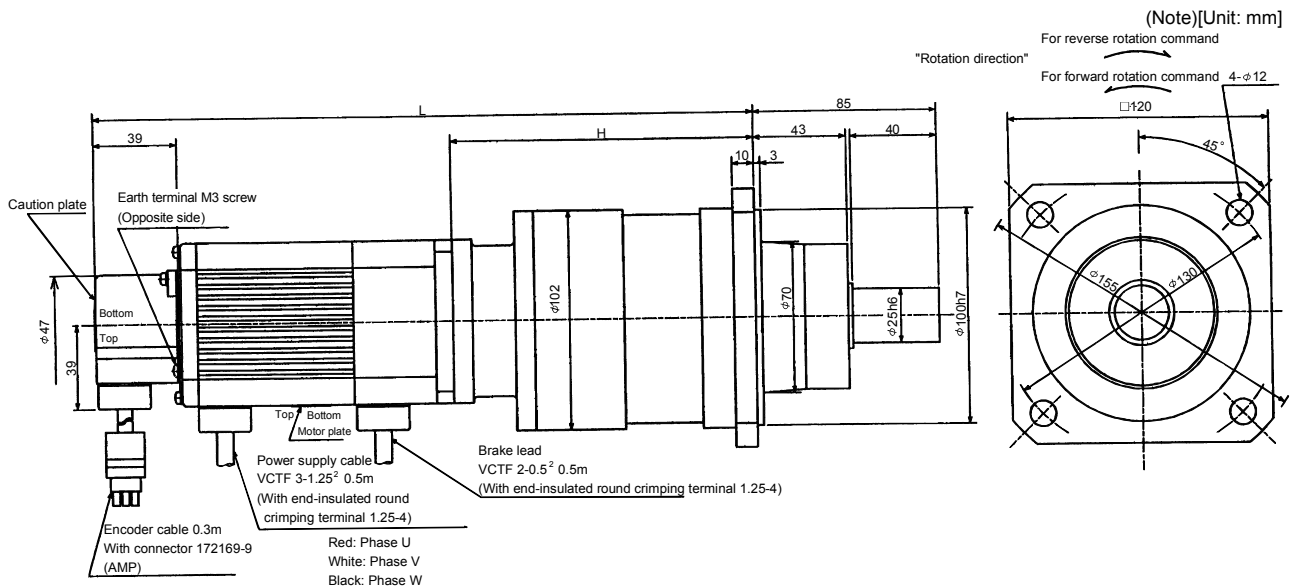

Note: The dimensions without tolerances are reference dimensions.

7. OUTLINE DIMENSION DRAWINGS

Model	Output [W]	Variable dimensions L	Brake static friction torque [N · m]	Reduction Gear Model	Reduction Ratio	Inertia Moment J [$\times 10^{-4}$ kg · m ²]	Backlash	Mass [kg]
HA-FF23BG2	200	336	1.2	BL2-45B-02MES	1/45	0.895	3 min. max.	12.9
HA-FF33BG2	300	353.5	1.2	BL2-29B-03MES	1/29	1.668	3 min. max.	13.2
HA-FF33BG2	300	363.5	1.2	BL2-45B-03MES	1/45	1.045	3 min. max.	13.2

(Note)[Unit: mm]

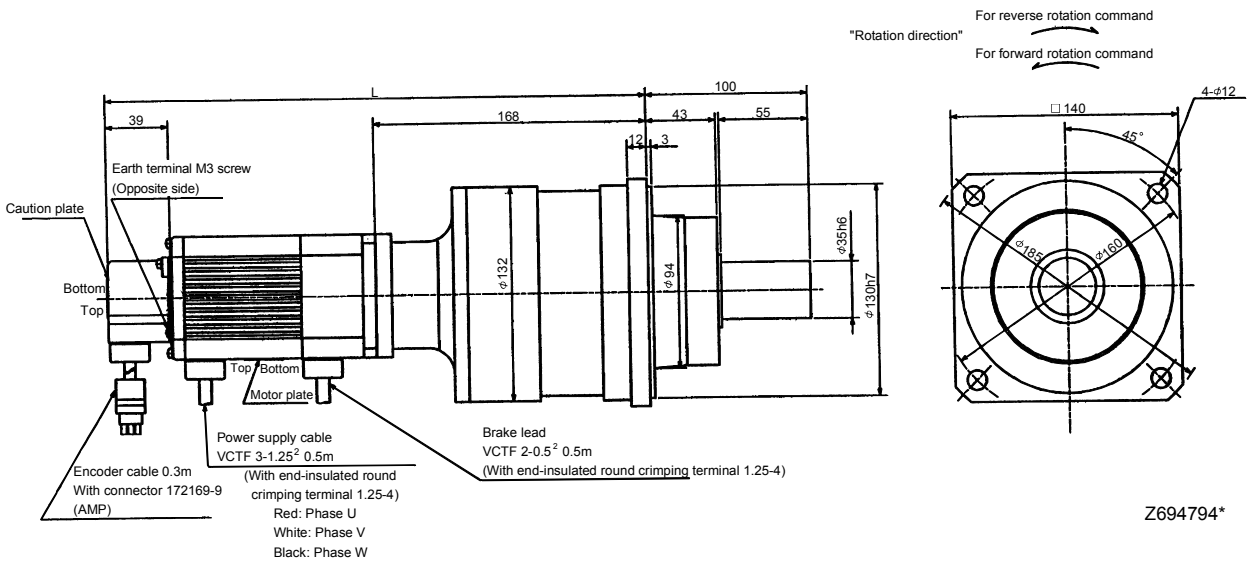

Z694794*

Note: The dimensions without tolerances are reference dimensions.

Model	Output [W]	Brake static friction torque [N · m]	Reduction Gear Model	Reduction Ratio	Inertia Moment J [$\times 10^{-4}$ kg · m ²]	Backlash	Mass [kg]
HA-FF33BG2	300	1.2	BM4-05B-03MES	1/5	0.95	3 min. max.	6.7

(Note)[Unit: mm]

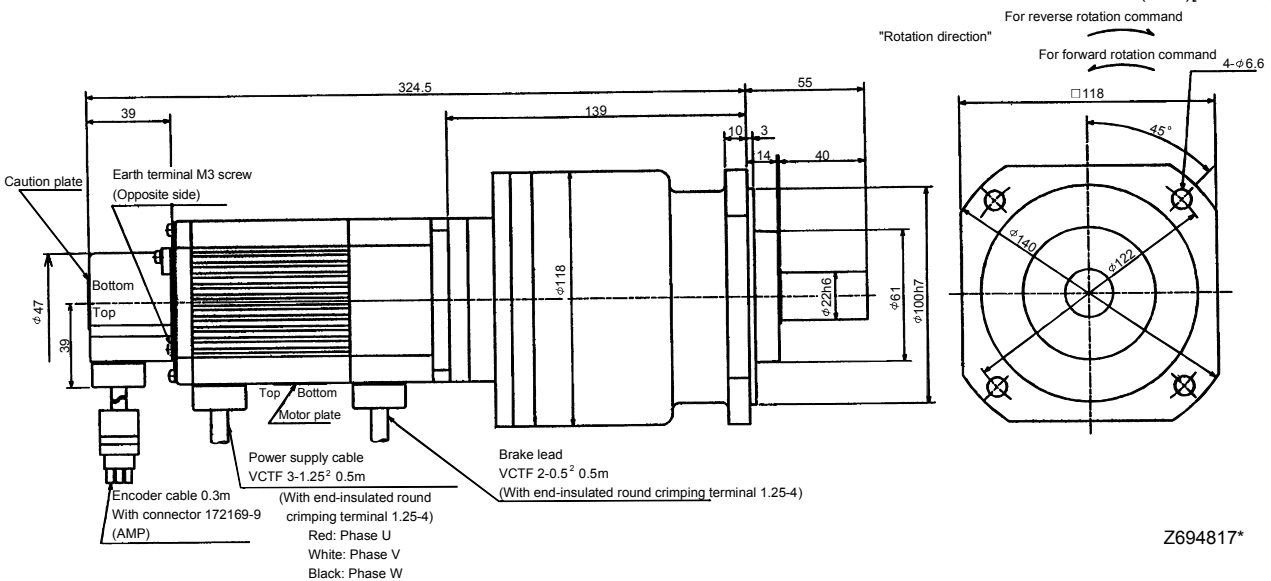

Z694817*

Note: The dimensions without tolerances are reference dimensions.

7. OUTLINE DIMENSION DRAWINGS

Model	Output [W]	Brake static friction torque [N · m]	Reduction Gear Model	Reduction Ratio	Inertia Moment $J[\times 10^{-4} \text{kg} \cdot \text{m}^2]$	Backlash	Mass [kg]
HA-FF43BG2	400	2.3	BM4-05B-04MES	1/5	1.643	3 min. max.	8.5

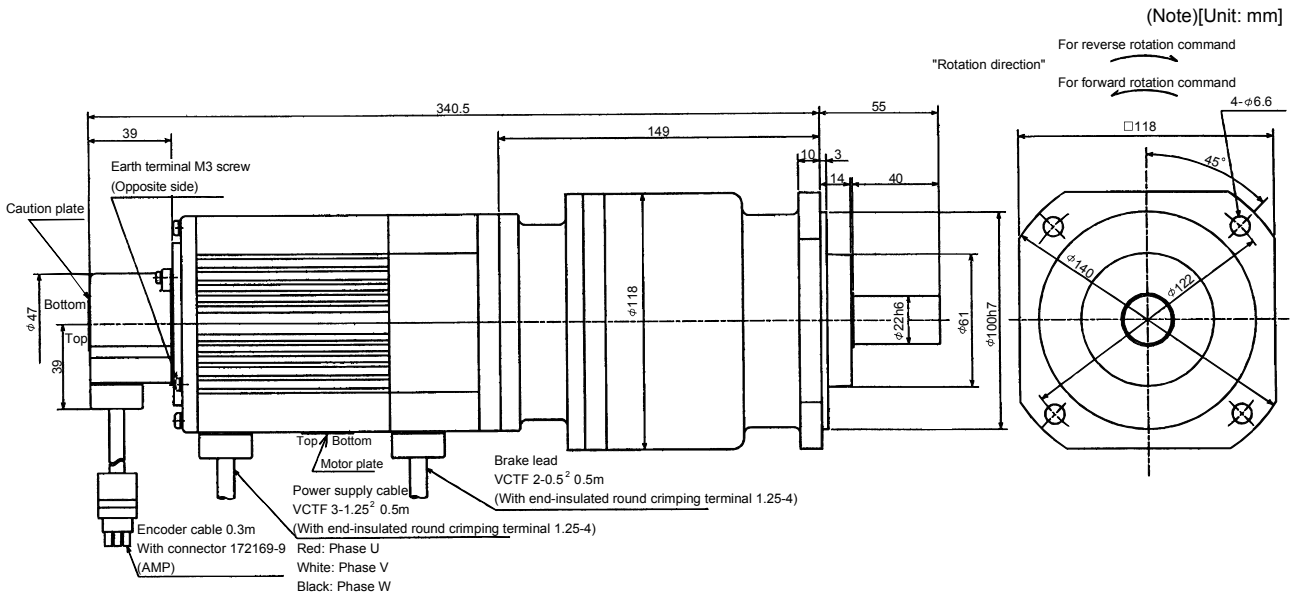

Note: The dimensions without tolerances are reference dimensions.

Z694818*

Model	Output [W]	Variable dimensions		Brake static friction torque [N · m]	Reduction Gear Model	Reduction Ratio	Inertia Moment $J[\times 10^{-4} \text{kg} \cdot \text{m}^2]$	Backlash	Mass [kg]
		L	H						
HA-FF43BG2	400	332.5	141	2.3	BL1-09B-04MES	1/9	1.543	3 min. max.	9.0
HA-FF63BG2	600	337.5	131	2.3	BL1-05B-06MES	1/5	1.858	3 min. max.	9.6
HA-FF63BG2	600	347.5	141	2.3	BL1-09B-06MES	1/9	1.768	3 min. max.	9.6

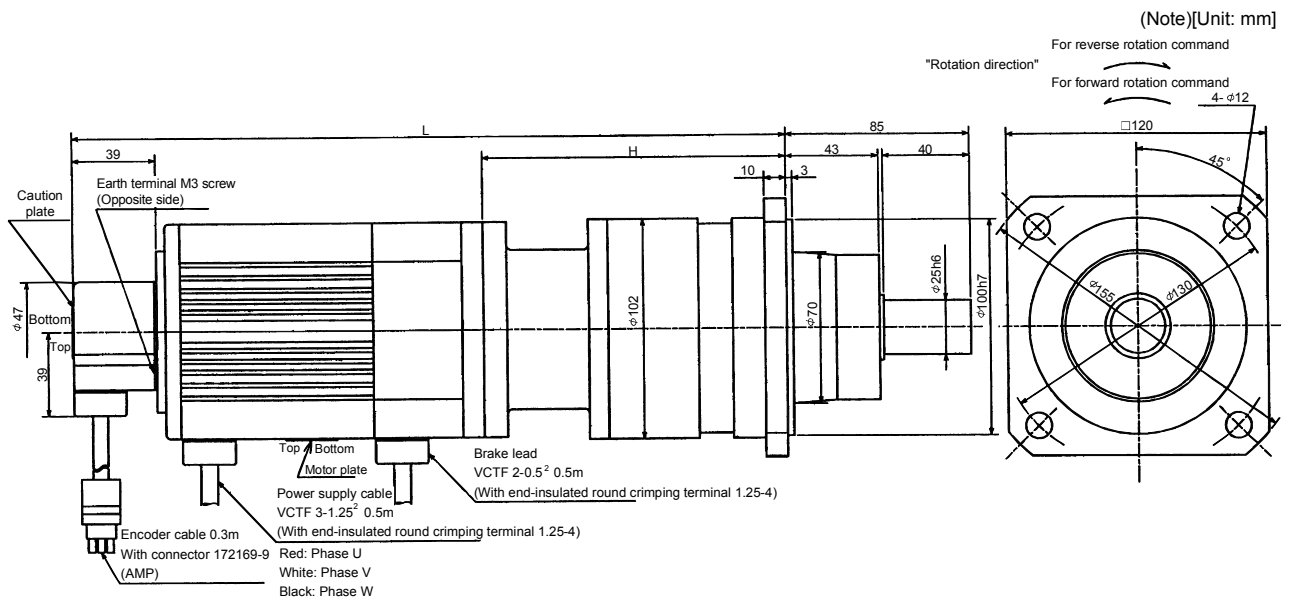

Note: The dimensions without tolerances are reference dimensions.

Z694795*

7. OUTLINE DIMENSION DRAWINGS

Model	Output [W]	Variable dimensions		Brake static friction torque [N · m]	Reduction Gear Model	Reduction Ratio	Inertia Moment J [$\times 10^{-4}$ kg · m ²]	Backlash	Mass [kg]
		L	H						
HA-FF43BG2	400	360.5	169	2.3	BL2-20B-04MES	1/20	2.623	3 min. max.	15
HA-FF43BG2	400	360.5	169	2.3	BL2-29B-04MES	1/29	2.36	3 min. max.	15
HA-FF43BG2	400	370.5	179	2.3	BL2-45B-04MES	1/45	1.738	3 min. max.	15
HA-FF63BG2	600	375.5	169	2.3	BL2-20B-06MES	1/20	2.953	3 min. max.	15.6
HA-FF63BG2	600	375.5	169	2.3	BL2-29B-06MES	1/29	2.585	3 min. max.	15.6

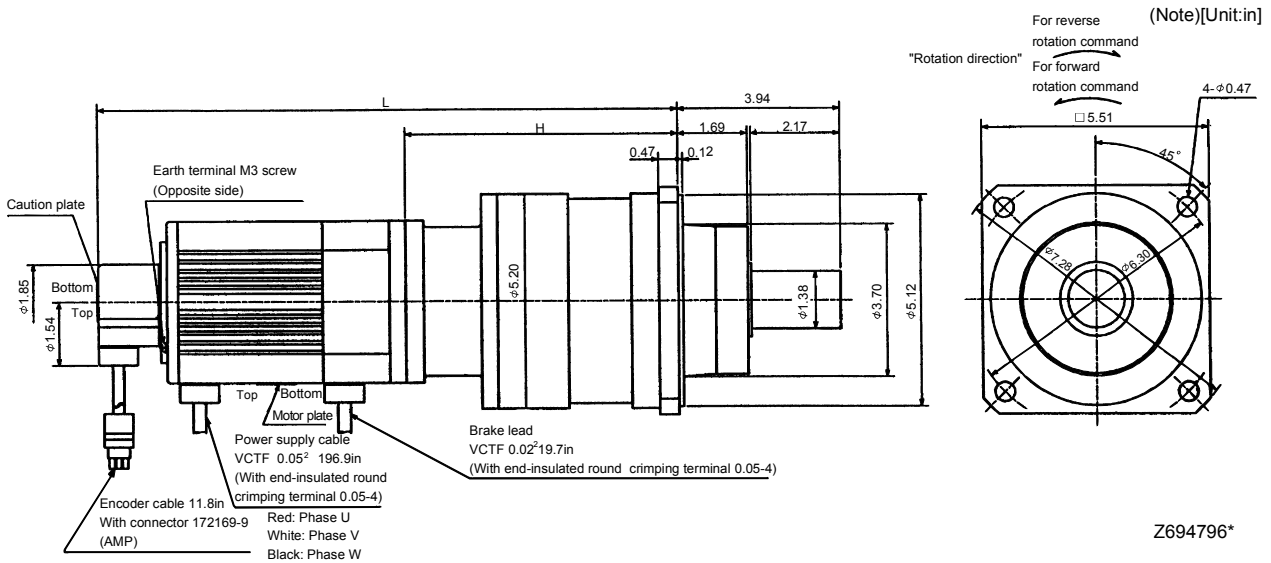

Note: The dimensions without tolerances are reference dimensions.

Model	Output [W]	Brake static friction torque [N · m]	Reduction Gear Model	Reduction Ratio	Inertia Moment J [$\times 10^{-4}$ kg · m ²]	Backlash	Mass [kg]
HA-FF63BG2	600	2.3	BM3-45B-06MES	1/45	3.475	3 min. max.	33.7

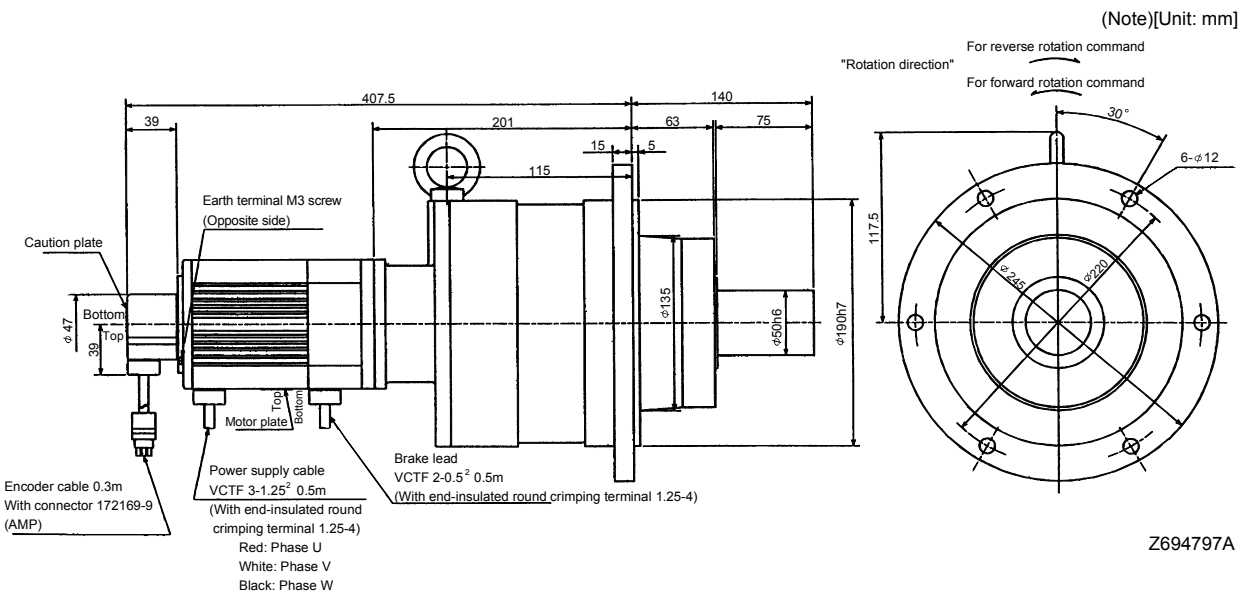

Note: The dimensions without tolerances are reference dimensions.

7. OUTLINE DIMENSION DRAWINGS

(5) EN · UL/C-UL Standard-Compliant model

(a) Standard (without electromagnetic brake, without reduction gear)

Model	Output [W]	Inertia Moment $J[\times 10^{-4} \text{kg} \cdot \text{m}^2]$	Mass [kg]
HA-FF053C-UE	50	0.063	1.8

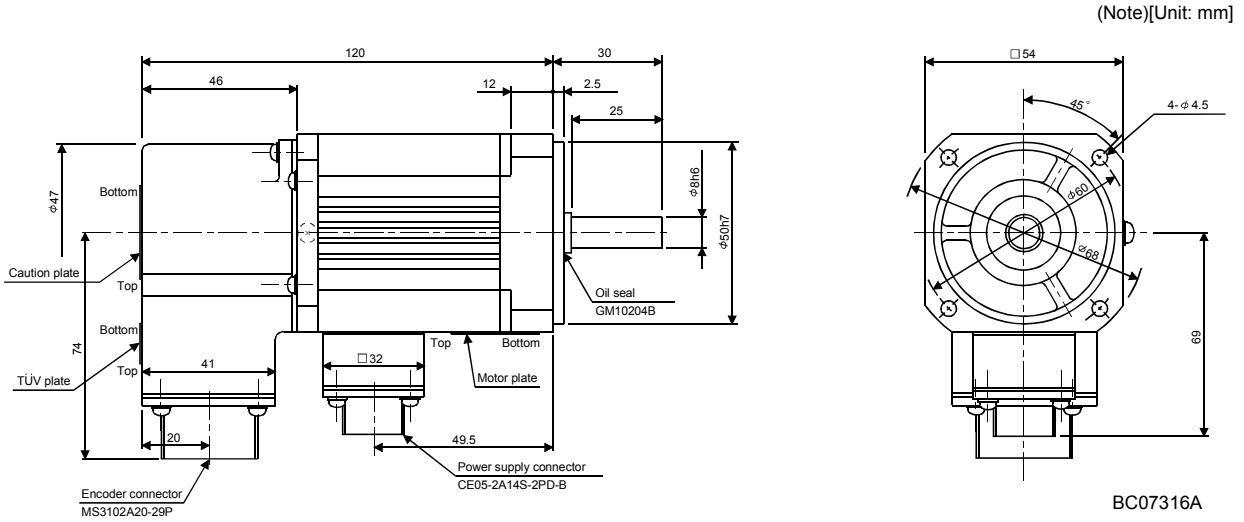

Note: The dimensions without tolerances are reference dimensions.

Model	Output [W]	Inertia Moment $J[\times 10^{-4} \text{kg} \cdot \text{m}^2]$	Mass [kg]
HA-FF13C-UE	100	0.10	2

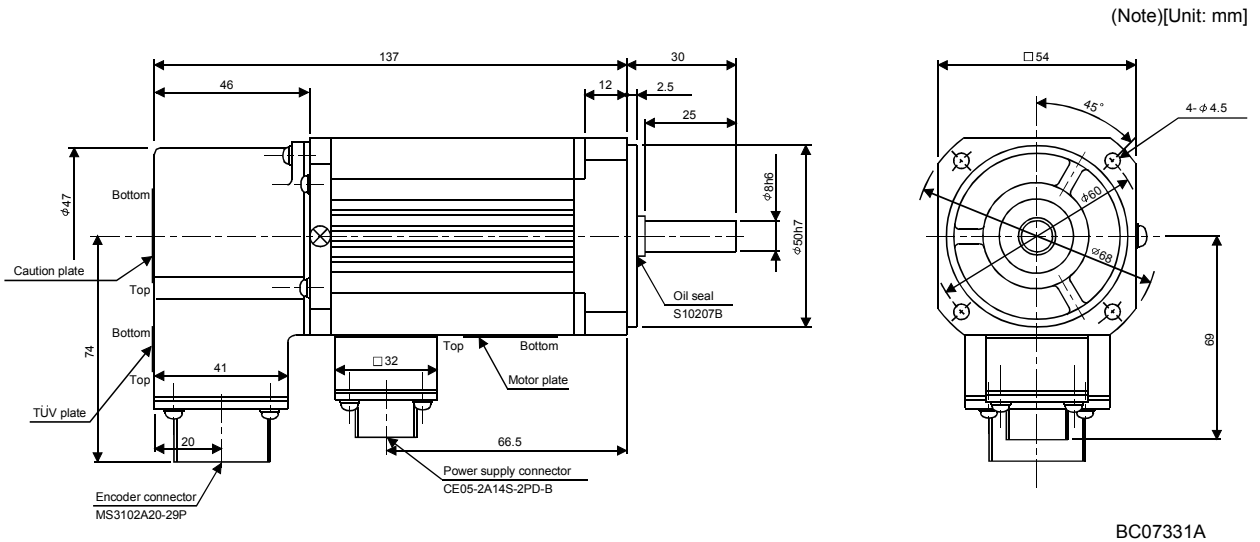

Note: The dimensions without tolerances are reference dimensions.

7. OUTLINE DIMENSION DRAWINGS

Model	Output [W]	Variable Dimensions		Inertia Moment $J[\times 10^{-4} \text{ kg} \cdot \text{m}^2]$	Mass [kg]
		L	KL		
HA-FF23C-UE	200	145	71.5	0.35	2.6
HA-FF33C-UE	300	162	89	0.50	2.9

(Note)[Unit: mm]

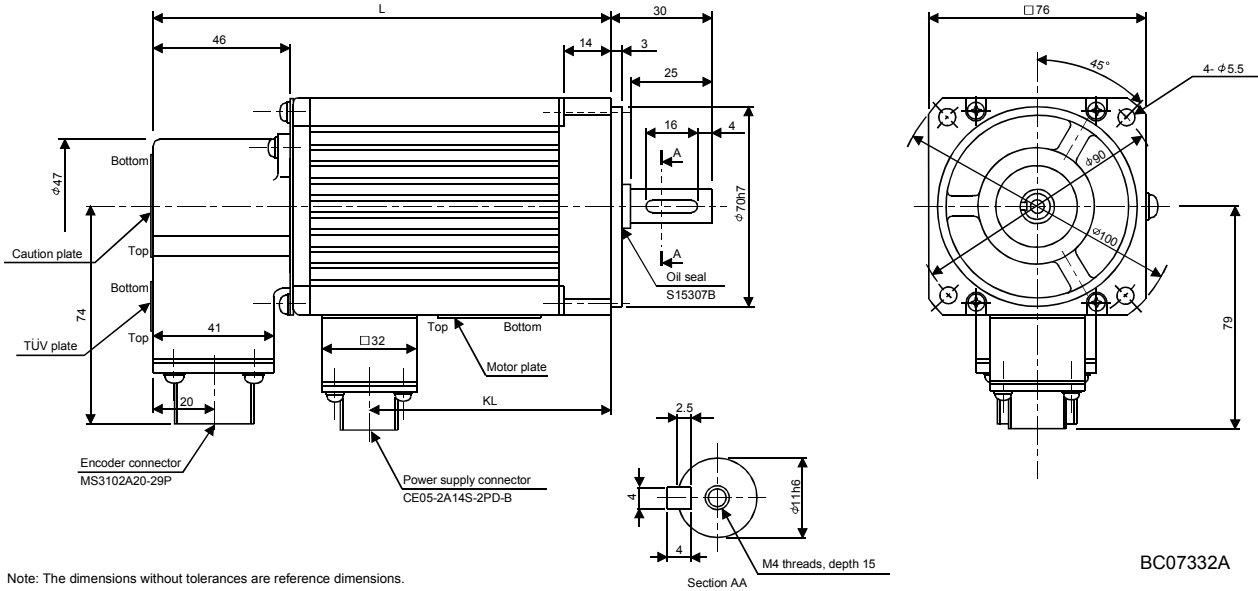

Note: The dimensions without tolerances are reference dimensions.

BC07332A

Model	Output [W]	Variable Dimensions		Inertia Moment $J[\times 10^{-4} \text{ kg} \cdot \text{m}^2]$	Mass [kg]
		L	KL		
HA-FF43C-UE	400	169	93	0.98	4.7
HA-FF63C-UE	600	184	108	1.2	5.3

(Note)[Unit: mm]

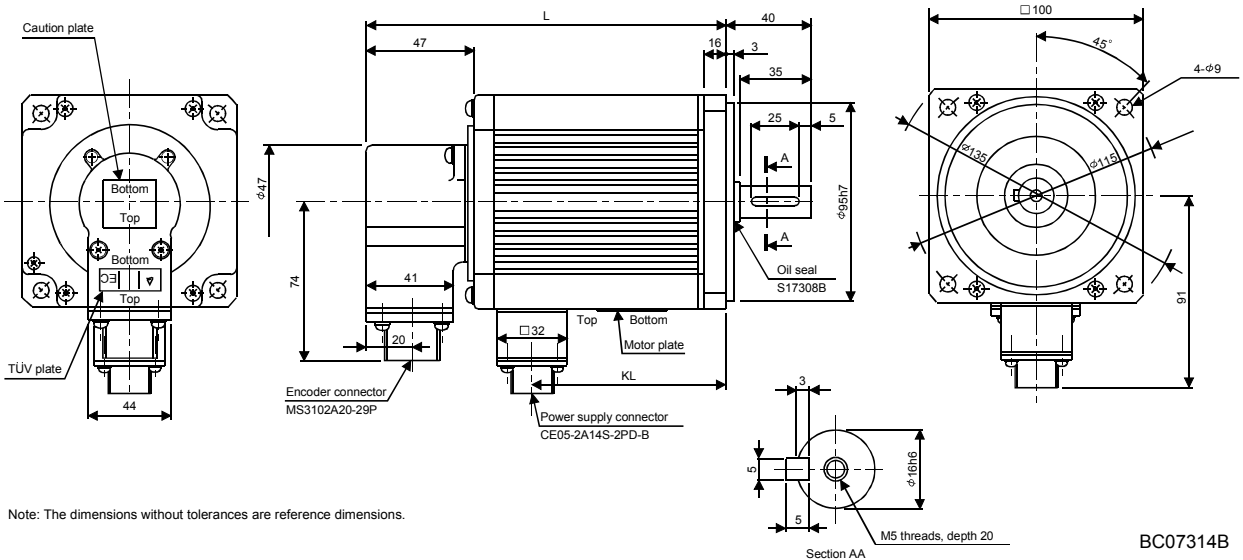

Note: The dimensions without tolerances are reference dimensions.

BC07314B

7. OUTLINE DIMENSION DRAWINGS

(b) With electromagnetic brake

Model	Output [W]	Inertia Moment $J[\times 10^{-4} \text{ kg} \cdot \text{m}^2]$	Brake static friction torque [N · m]	Mass [kg]
HA-FF053CB-UE	50	0.08	0.39	2.1

(Note)[Unit: mm]

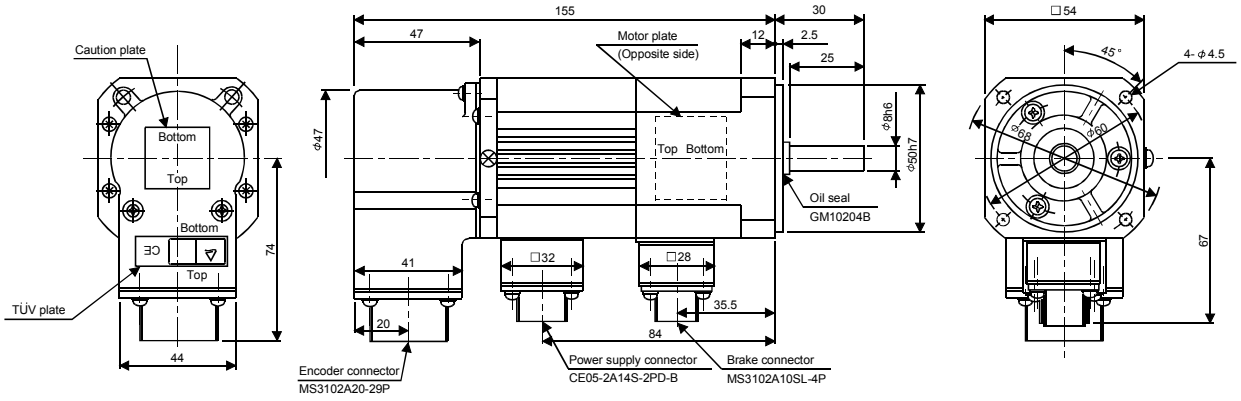

Note: The dimensions without tolerances are reference dimensions.

BC08269A

Model	Output [W]	Inertia Moment $J[\times 10^{-4} \text{ kg} \cdot \text{m}^2]$	Brake static friction torque [N · m]	Mass [kg]
HA-FF13CB-UE	100	0.11	0.39	2.3

(Note)[Unit: mm]

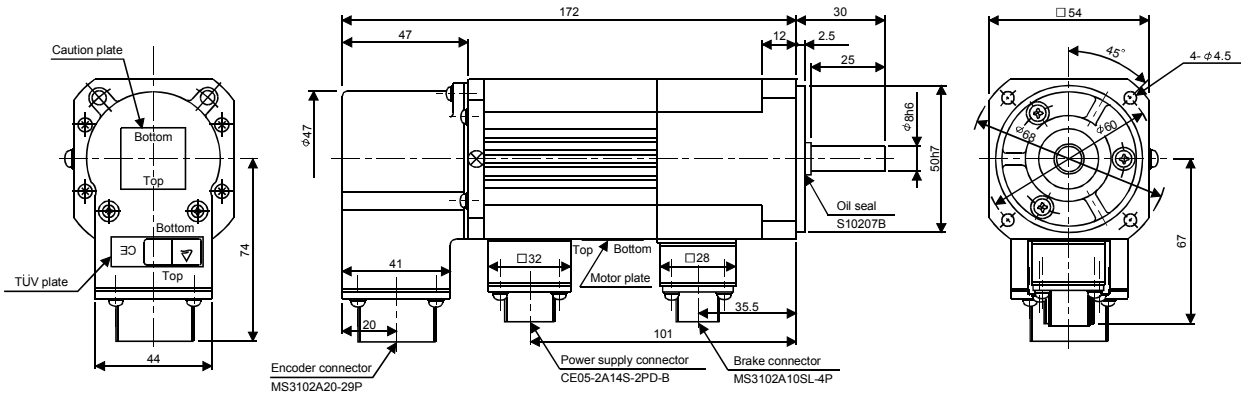

Note: The dimensions without tolerances are reference dimensions.

BC07372A

7. OUTLINE DIMENSION DRAWINGS

Model	Output [W]	Variable Dimensions		Brake static friction torque [N · m]	Inertia Moment J [$\times 10^{-4}$ kg · m ²]	Mass [kg]
		L	KL			
HA-FF23CB-UE	200	182	109	1.2	0.48	3.5
HA-FF33CB-UE	300	200	127		0.63	3.8

(Note)[Unit: mm]

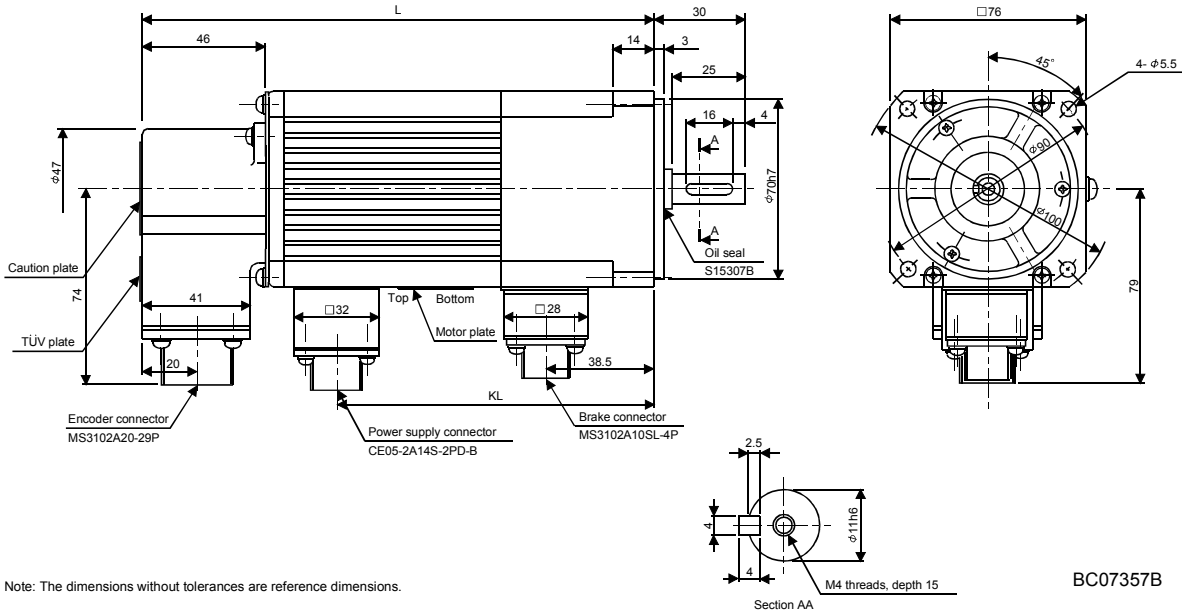

Note: The dimensions without tolerances are reference dimensions.

BC07357B

Model	Output [W]	Variable Dimensions		Brake static friction torque [N · m]	Inertia Moment J [$\times 10^{-4}$ kg · m ²]	Mass [kg]
		L	KL			
HA-FF43CB-UE	400	206	130	2.3	1.33	5.8
HA-FF63CB-UE	600	221	145		1.55	6.4

(Note)[Unit: mm]

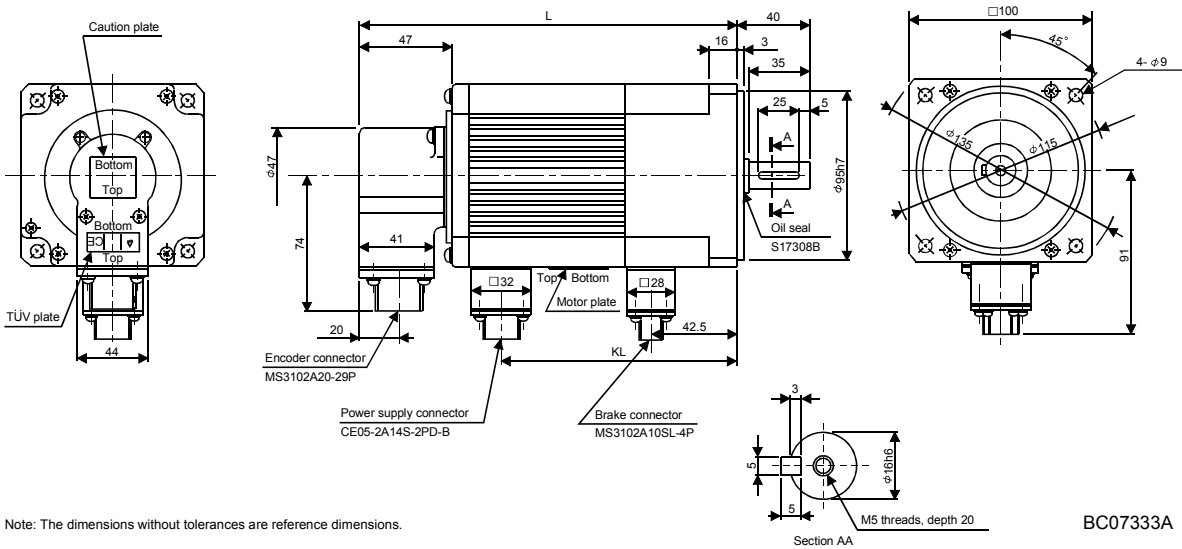

Note: The dimensions without tolerances are reference dimensions.

BC07333A

7. OUTLINE DIMENSION DRAWINGS

7.1.3 HC-SF • HC-SFS series

If the above indicated value is exceeded, please consult us.

(1) Standard (without electromagnetic brake, without reduction gear)

Model			Output [kW]	Variable dimensions		Inertia Moment J [$\times 10^{-4}$ kg · m ²]	Mass [kg]
		L		KL			
HC-SF52	HC-SFS52	HC-SFS524	0.5	120	51.5	6.6	5.0
HC-SF53	HC-SFS53						
HC-SF102	HC-SFS102	HC-SFS1024	1.0	145	76.5	13.7	7.0
HC-SF103	HC-SFS103						
HC-SF81	HC-SFS81	HC-SFS1524	0.85	170	101.5	20	9.0
HC-SF152	HC-SFS152		1.5				
HC-SF153	HC-SFS153						

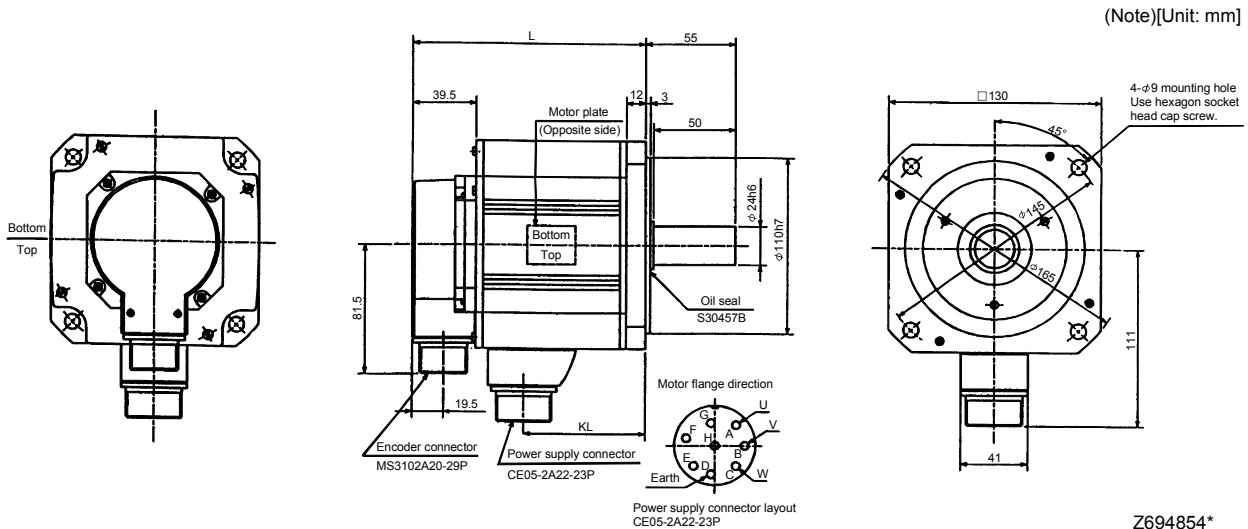

Note: The dimensions without tolerances are reference dimensions.

Z694854*
(BC11651*•BC11757*•BC11768*)

Model			Output [kW]	Variable dimensions		Inertia Moment J [$\times 10^{-4}$ kg · m ²]	Mass [kg]
		L		H			
HC-SF121	HC-SFS121	HC-SFS2024	2.0	145	68.5	42.5	12.0
HC-SF202	HC-SFS202						
HC-SF203	HC-SFS203						
HC-SF201	HC-SFS201	HC-SFS3524	3.5	187	110.5	82.0	19.0
HC-SF352	HC-SFS352						
HC-SF353	HC-SFS353						

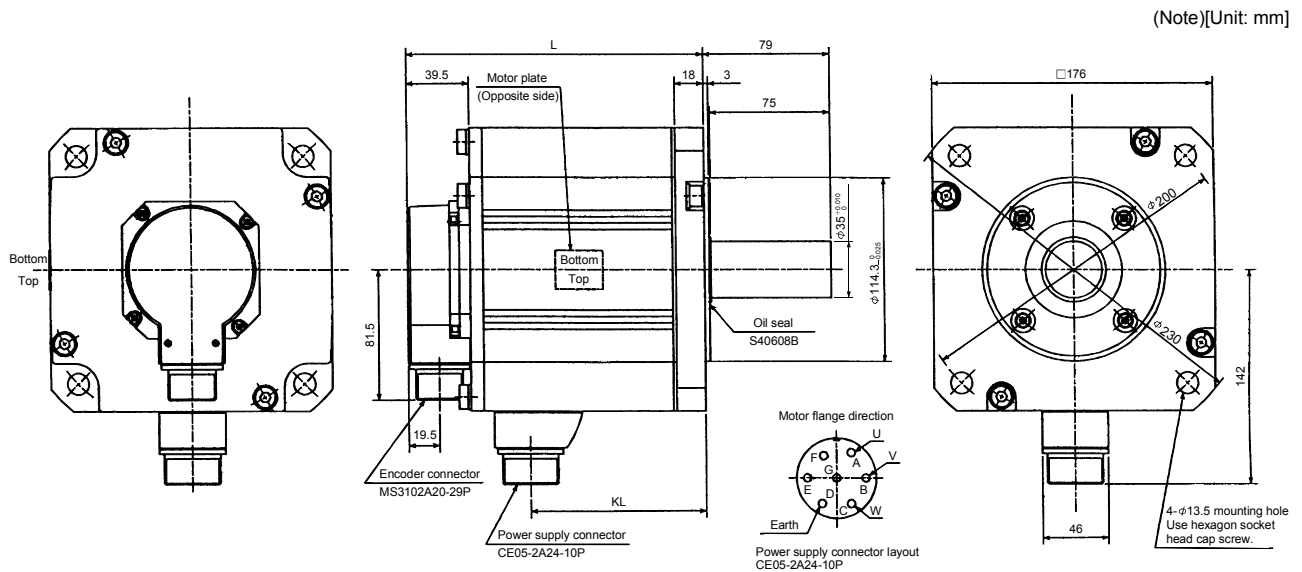

Note: The dimensions without tolerances are reference dimensions.

Z695393A*
(BC11769*•BC11652*•BC11758*)

7. OUTLINE DIMENSION DRAWINGS

Model		Output [kW]	Inertia Moment $J[\times 10^{-4} \text{kg} \cdot \text{m}^2]$	Mass [kg]
HC-SF301	HC-SFS301	3.0	101	23

(Note)[Unit: mm]

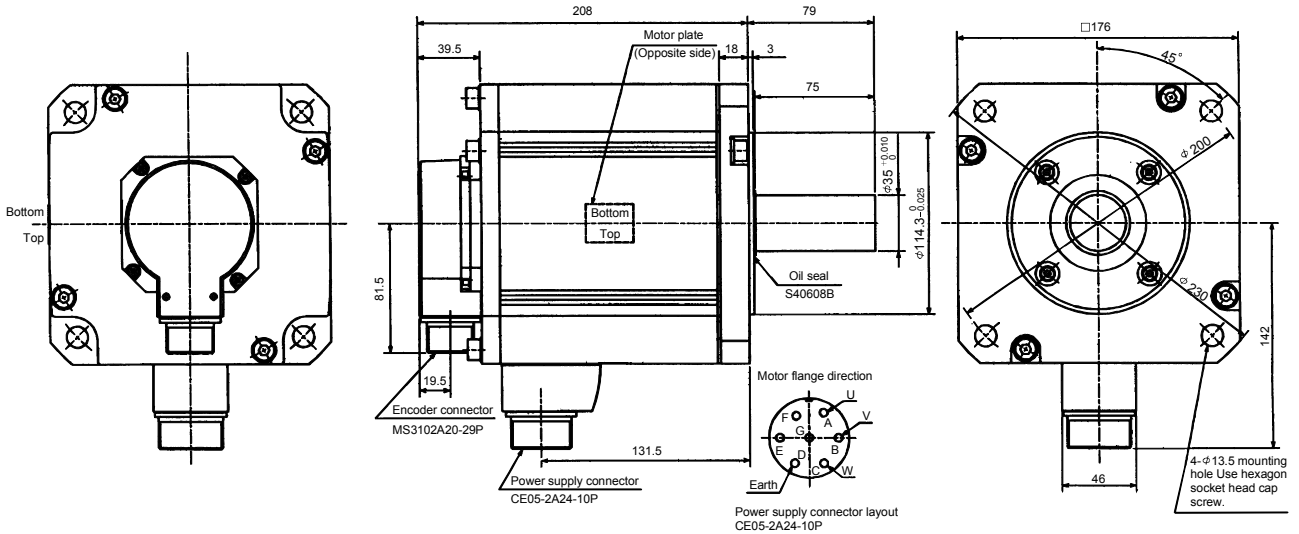

Note: The dimensions without tolerances are reference dimensions.

BC10628*
(BC11769*)

Model		Output [kW]	Inertia Moment $J[\times 10^{-4} \text{kg} \cdot \text{m}^2]$	Mass [kg]
HC-SF502	HC-SFS502 HC-SFS5024	5.0	101	23

(Note)[Unit: mm]

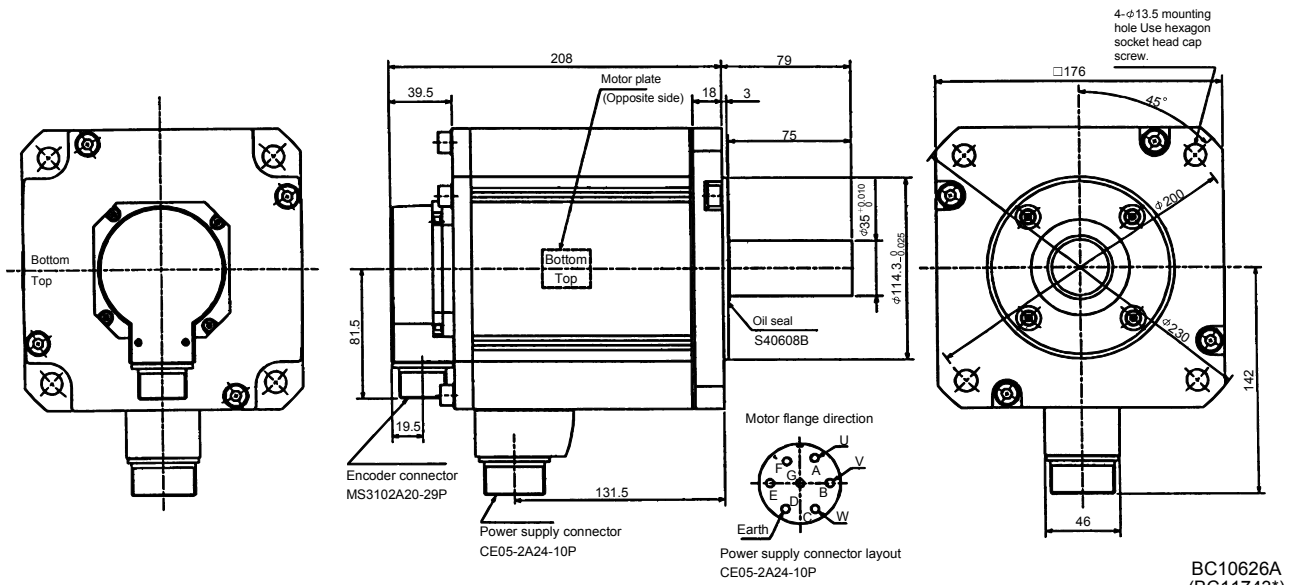

Note: The dimensions without tolerances are reference dimensions.

BC10626A
(BC11743*)

7. OUTLINE DIMENSION DRAWINGS

Model			Output [kW]	Inertia Moment $J[\times 10^{-4} \text{kg} \cdot \text{m}^2]$	Mass [kg]
HC-SF702	HC-SFS702	HC-SFS7024	7.0	160	32

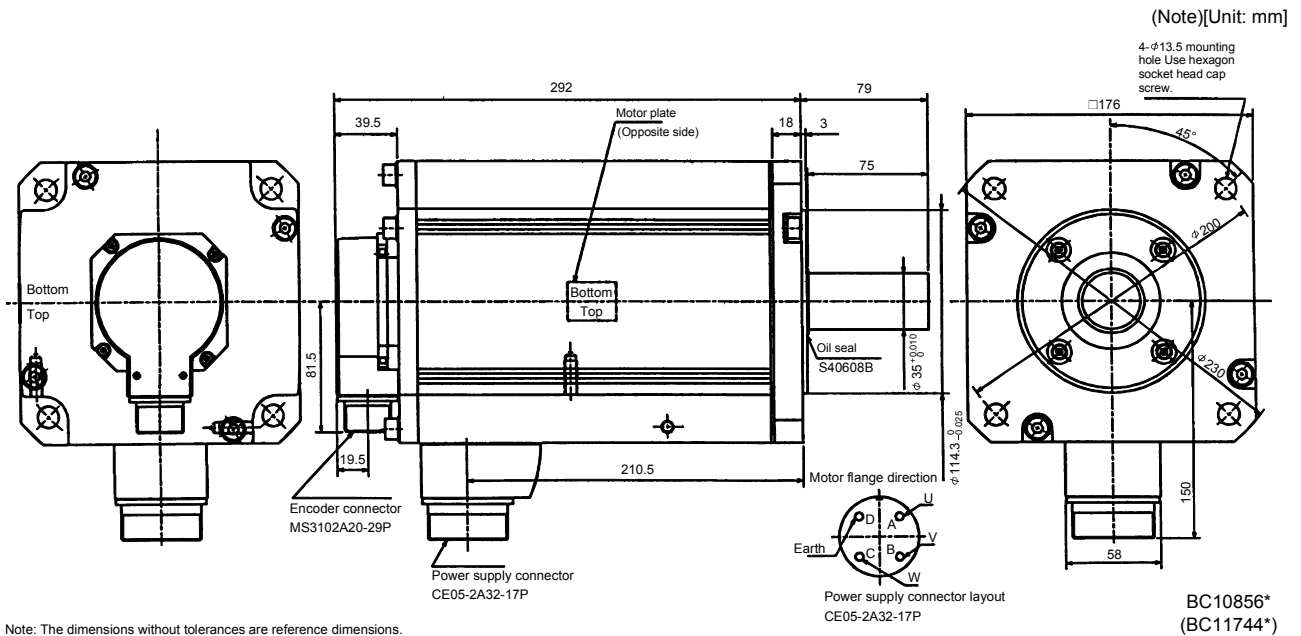

(2) With electromagnetic brake

Model			Output [kW]	Variable dimensions		Brake static friction torque [N · m]	Inertia Moment $J[\times 10^{-4} \text{kg} \cdot \text{m}^2]$	Mass [kg]
				L	KL			
HC-SF52B	HC-SFS52B	HC-SFS524B	0.5	153	51.5	8.5	8.3	7.5
HC-SF53B	HC-SFS53B	HC-SFS534B						
HC-SF102B	HC-SFS102B	HC-SFS1024B	1.0	178	76.5	8.5	15.4	9.5
HC-SF103B	HC-SFS103B	HC-SFS1034B						
HC-SF81B	HC-SFS81B		0.85	203	101.5	8.5	21.7	11.5
HC-SF152B	HC-SFS152B	HC-SFS1524B						
HC-SF153B	HC-SFS153B		1.5	203	101.5	8.5	21.7	11.5

(Note)[Unit: mm]

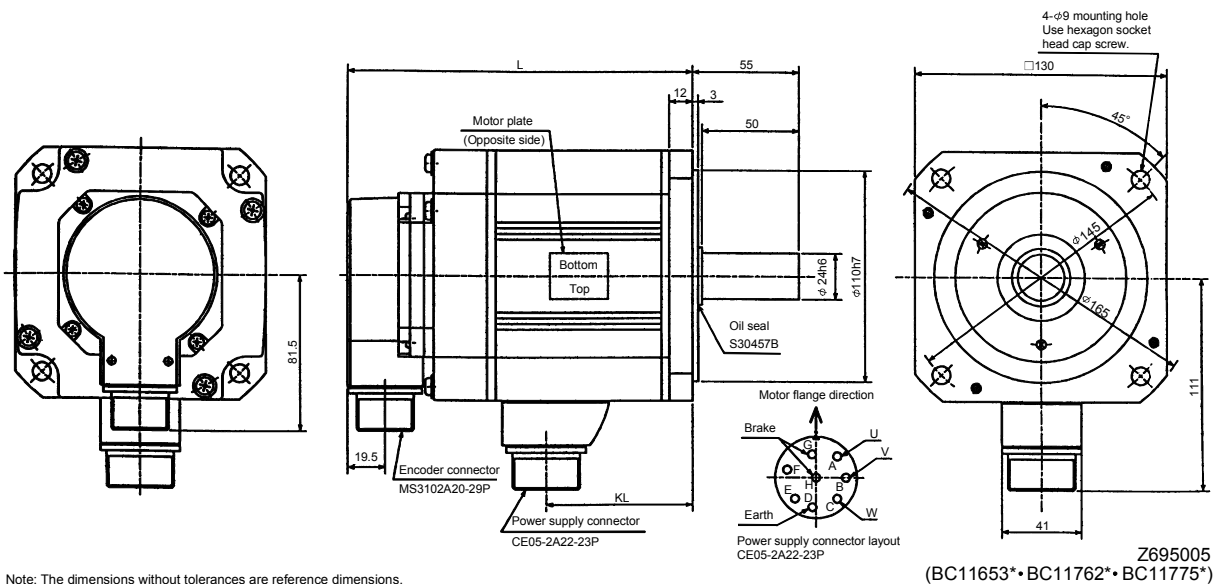

7. OUTLINE DIMENSION DRAWINGS

Model	Output [kW]	Variable dimensions		Brake static friction torque [N · m]	Inertia Moment J [$\times 10^{-4}$ kg · m ²]	Mass [kg]
		L	KL			
HC-SF121B HC-SFS121B	1.2	193	68.5	43.1	52.5	18.0
HC-SF202B HC-SFS202B	2.0					
HC-SF203B HC-SFS203B HC-SF204B HC-SFS204B	2.0					
HC-SF201B HC-SFS201B	2.0	235	110.5	43.1	92.0	25.0
HC-SF352B HC-SFS352B	3.5					
HC-SF353B HC-SFS353B HC-SF354B HC-SFS354B	3.5					

(Note)[Unit: mm]

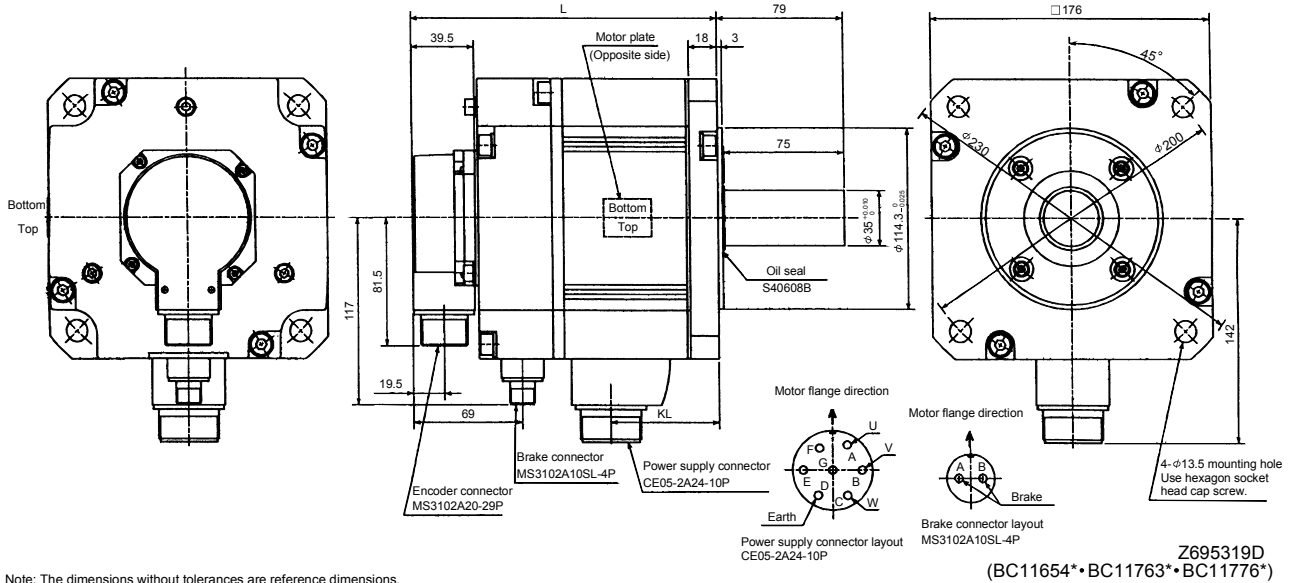

Model	Output [kW]	Brake static friction torque [N · m]	Inertia Moment J [$\times 10^{-4}$ kg · m ²]	Mass [kg]
HC-SF301B HC-SFS301B	3.0	43.1	111	29.0

(Note)[Unit: mm]

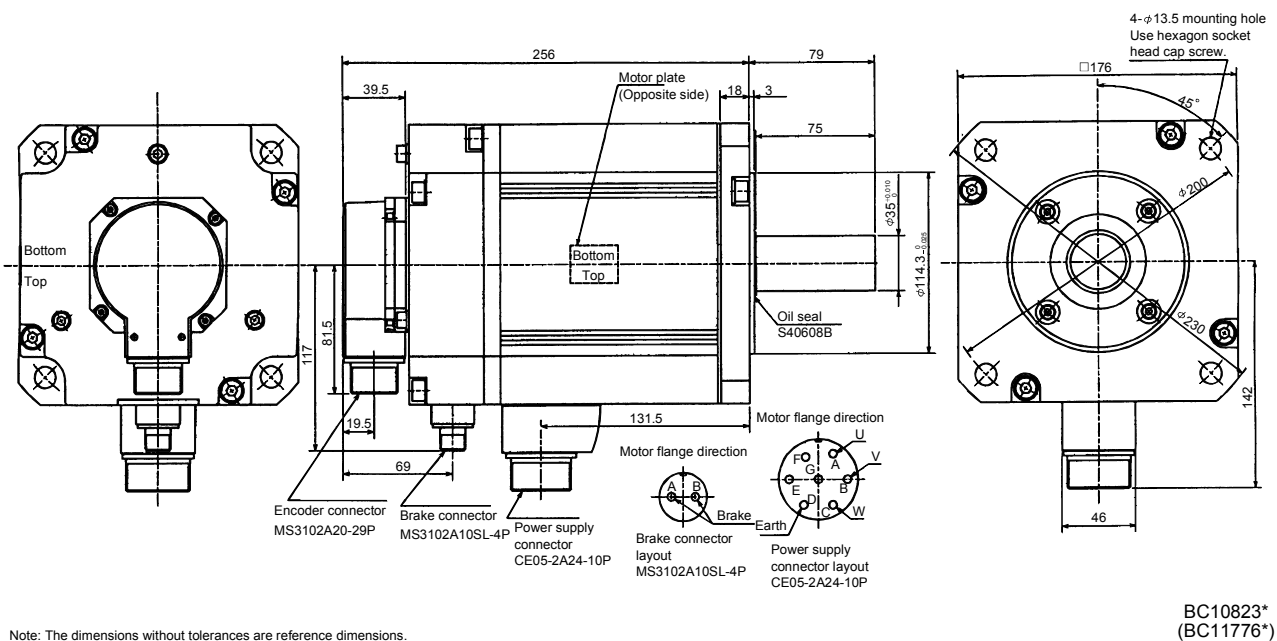

7. OUTLINE DIMENSION DRAWINGS

Model	Output [kW]	Brake static friction torque [N · m]	Inertia Moment $J[\times 10^{-4} \text{kg} \cdot \text{m}^2]$	Mass [kg]
HC-SF502B HC-SFS502B HC-SFS5024B	5.0	43.1	111	29.0

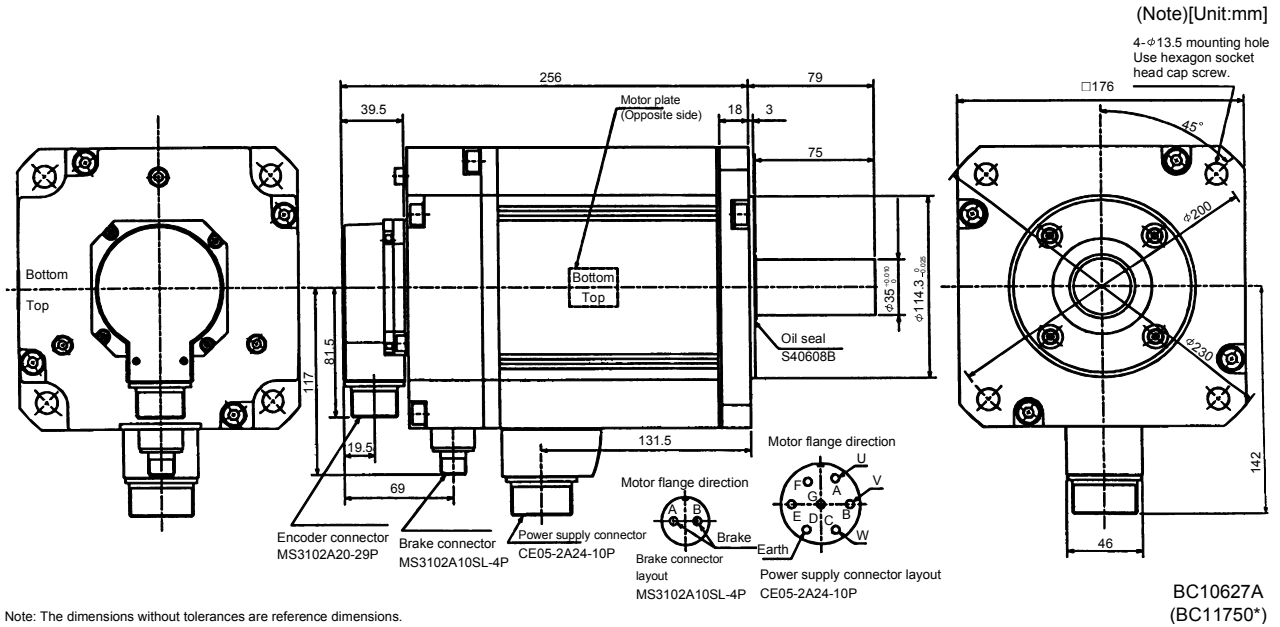

Note: The dimensions without tolerances are reference dimensions.

Model	Output [kW]	Brake static friction torque [N · m]	Inertia Moment $J[\times 10^{-4} \text{kg} \cdot \text{m}^2]$	Mass [kg]
HC-SF702B HC-SFS702B HC-SFS7024B	7.0	43.1	170	38.0

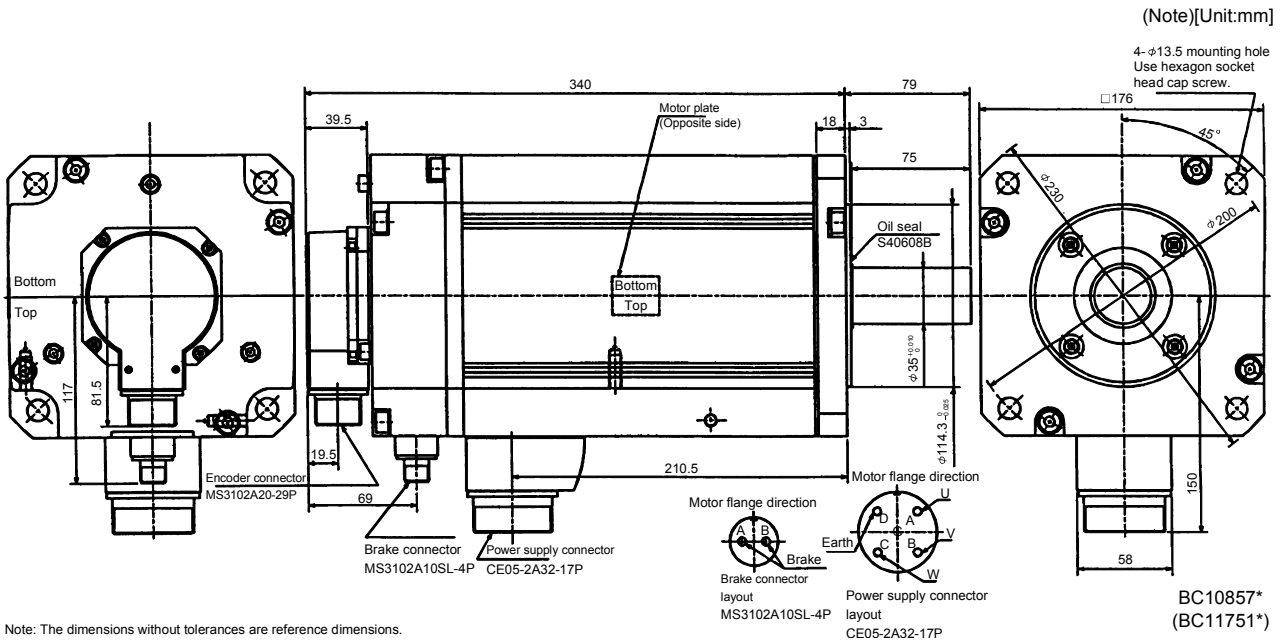

Note: The dimensions without tolerances are reference dimensions.

7. OUTLINE DIMENSION DRAWINGS

(3) With reduction gear for general industrial machine (leg type)

The outer frame of the reduction gear is a material surface such as casting. Its actual dimensions may be 1 to 3mm larger than the drawing dimensions. Design the machine side with allowances.

(a) Without electromagnetic brake

Model			Output [kW]	Reduction Ratio	Inertia Moment $J[\times 10^{-4} \text{kg} \cdot \text{m}^2]$	Variable Dimensions	Mass [kg]
						L	
HC-SF52G1H	HC-SFS52G1H	HC-SFS524G1H	0.5	1/35	7.5	338	28
HC-SF52G1H	HC-SFS52G1H	HC-SFS524G1H	0.5	1/43	7.45	338	28
HC-SF52G1H	HC-SFS52G1H	HC-SFS524G1H	0.5	1/59	7.43	338	28
HC-SF102G1H	HC-SFS102G1H	HC-SFS1024G1H	1.0	1/6	16.8	363	30
HC-SF102G1H	HC-SFS102G1H	HC-SFS1024G1H	1.0	1/11	15.3	363	30
HC-SF102G1H	HC-SFS102G1H	HC-SFS1024G1H	1.0	1/17	14.9	363	30
HC-SF102G1H	HC-SFS102G1H	HC-SFS1024G1H	1.0	1/29	14.6	363	30
HC-SF102G1H	HC-SFS102G1H	HC-SFS1024G1H	1.0	1/35	14.6	363	30
HC-SF152G1H	HC-SFS152G1H	HC-SFS1524G1H	1.5	1/6	23.1	388	32
HC-SF152G1H	HC-SFS152G1H	HC-SFS1524G1H	1.5	1/11	21.5	388	32
HC-SF152G1H	HC-SFS152G1H	HC-SFS1524G1H	1.5	1/17	21.2	388	32

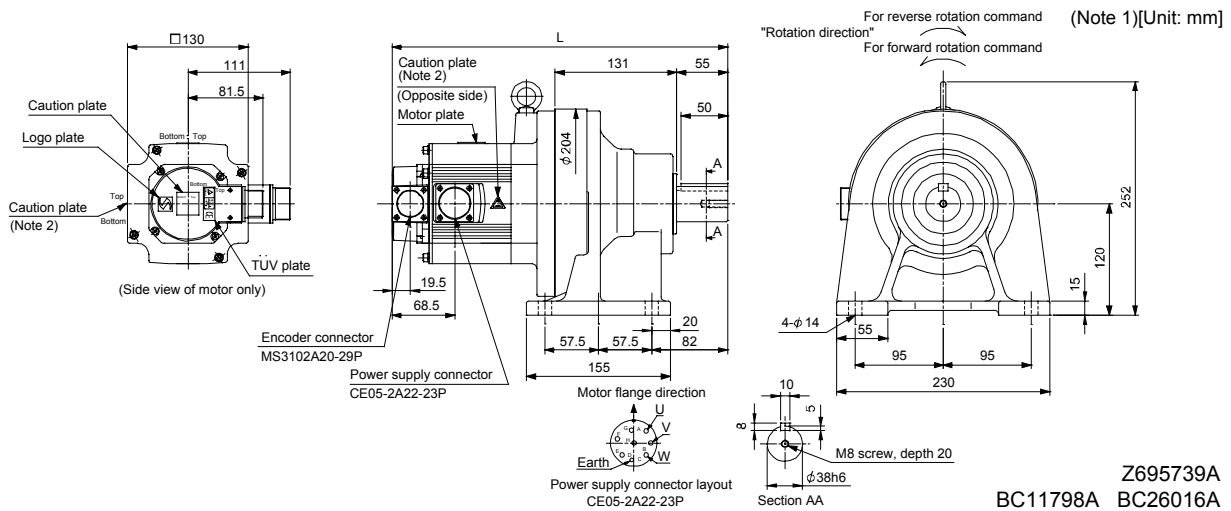

Note 1. The dimensions without tolerances are reference dimensions.
2. This caution plate is attached to the 400V class motors only, not to the 200V class.

Model			Output [kW]	Reduction Ratio	Inertia Moment $J[\times 10^{-4} \text{kg} \cdot \text{m}^2]$	Mass [kg]
HC-SF52G1H	HC-SFS52G1H	HC-SFS524G1H	0.5	1/6	7.33	21
HC-SF52G1H	HC-SFS52G1H	HC-SFS524G1H	0.5	1/11	6.95	21
HC-SF52G1H	HC-SFS52G1H	HC-SFS524G1H	0.5	1/17	6.85	21
HC-SF52G1H	HC-SFS52G1H	HC-SFS524G1H	0.5	1/29	6.78	21

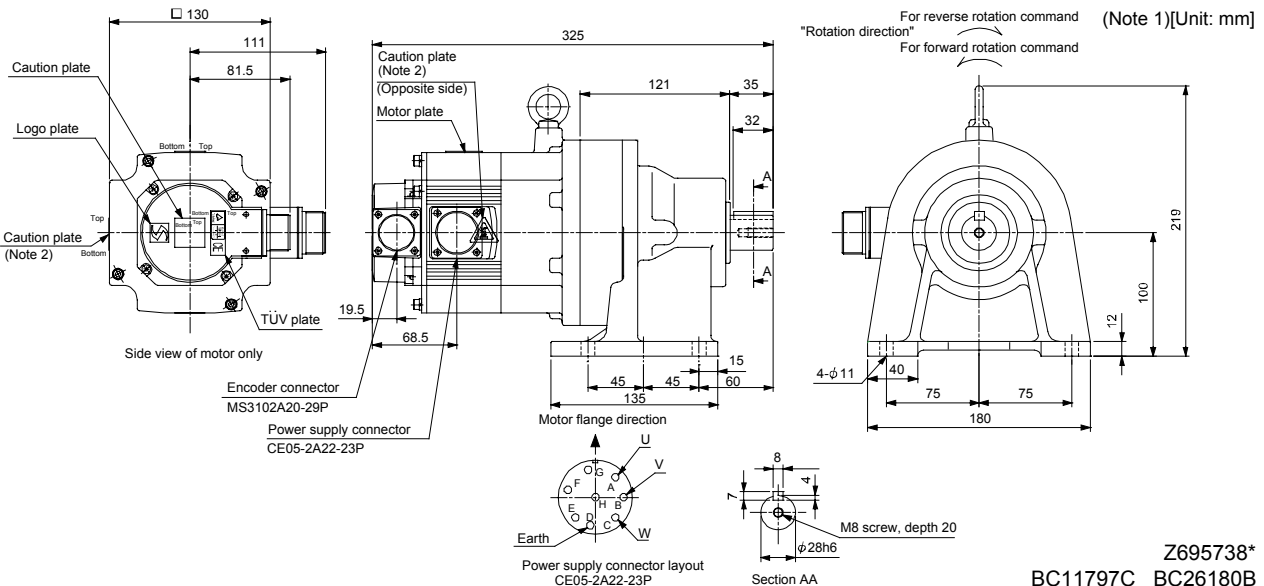

Note 1. The dimensions without tolerances are reference dimensions.
2. This caution plate is attached to the 400V class motors only, not to the 200V class.

7. OUTLINE DIMENSION DRAWINGS

Model			Output [kW]	Reduction Ratio	Inertia Moment $J[\times 10^{-4} \text{kg} \cdot \text{m}^2]$	Variable Dimensions	Mass [kg]
						L	
HC-SF102G1H	HC-SFS102G1H	HC-SFS1024G1H	1.0	1/59	19.48	488	90
HC-SF152G1H	HC-SFS152G1H	HC-SFS1524G1H	1.5	1/43	25.8	513	92
HC-SF152G1H	HC-SFS152G1H	HC-SFS1524G1H	1.5	1/59	25.73	513	92

(Note)[Unit: mm]

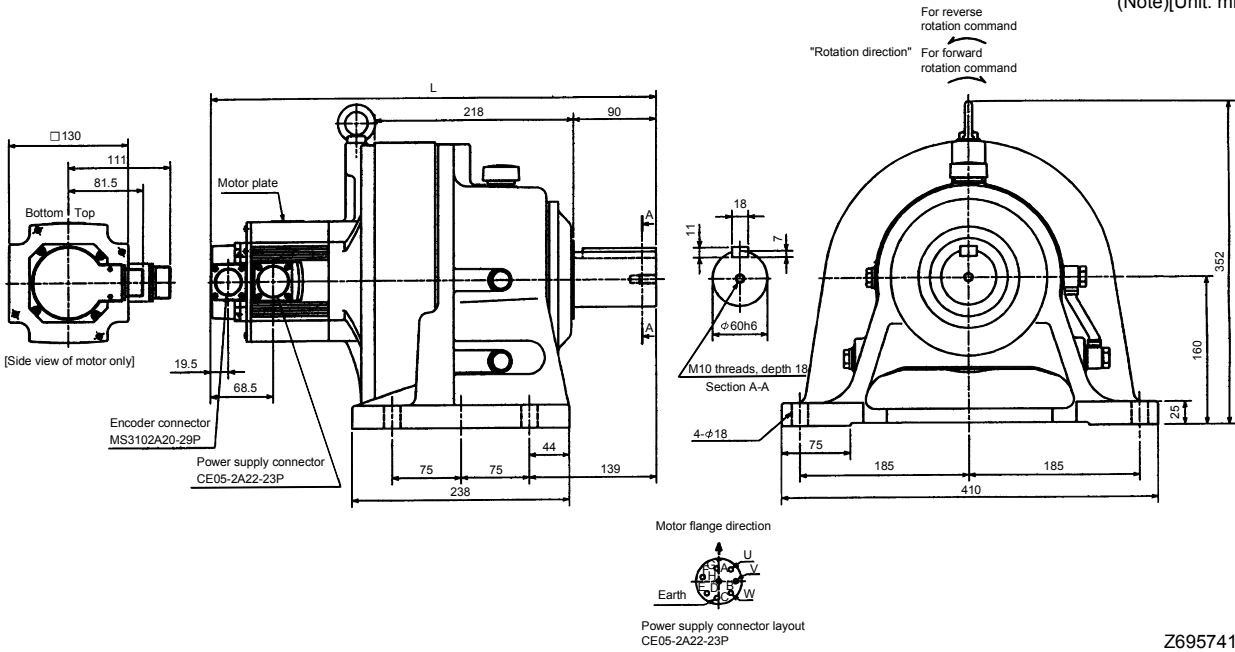

Note: The dimensions without tolerances are reference dimensions.

Z695741*
(BC11800*)

Model			Output [kW]	Reduction Ratio	Inertia Moment $J[\times 10^{-4} \text{kg} \cdot \text{m}^2]$	Variable Dimensions	Mass [kg]
						L	
HC-SF102G1H	HC-SFS102G1H	HC-SFS1024G1H	1.0	1/43	15.65	416	51
HC-SF152G1H	HC-SFS152G1H	HC-SFS1524G1H	1.5	1/29	22.08	441	53
HC-SF152G1H	HC-SFS152G1H	HC-SFS1524G1H	1.5	1/35	22.03	441	53

(Note)[Unit: mm]

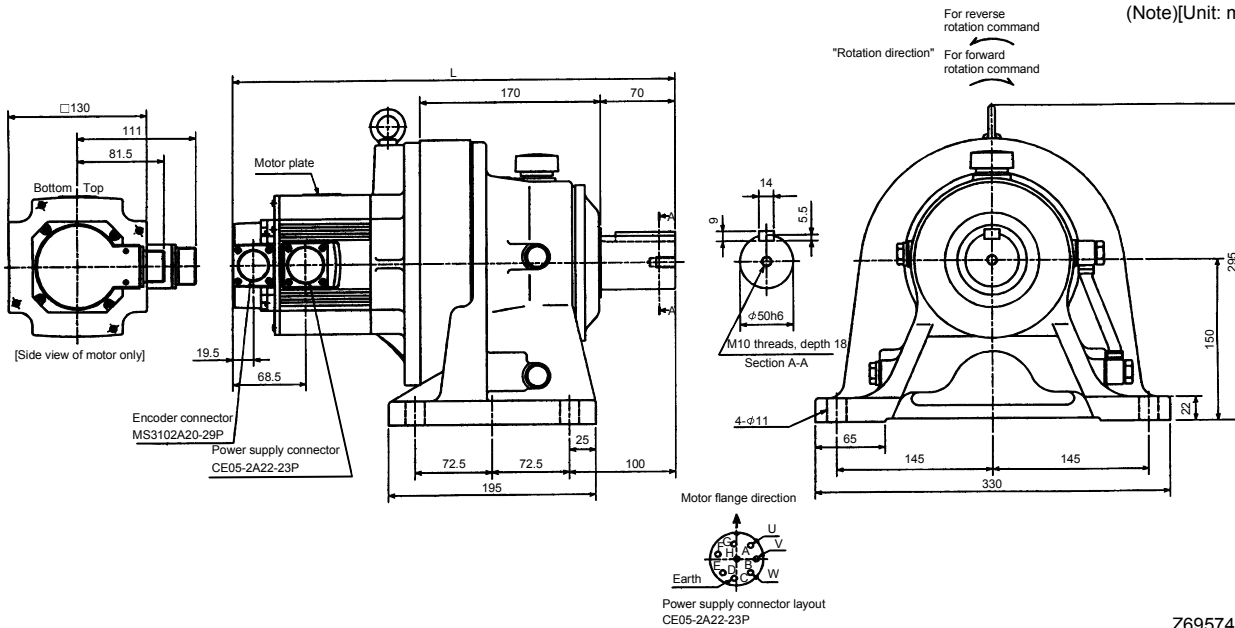

Note: The dimensions without tolerances are reference dimensions.

Z695740*
(BC11799*)

7. OUTLINE DIMENSION DRAWINGS

Model	Output [kW]	Reduction Ratio	Inertia Moment $J[\times 10^{-4} \text{ kg} \cdot \text{m}^2]$	Mass [kg]
HC-SF202G1H HC-SFS202G1H HC-SFS2024G1H	2.0	1/6	45.6	35
HC-SF202G1H HC-SFS202G1H HC-SFS2024G1H	2.0	1/11	44.1	35
HC-SF202G1H HC-SFS202G1H HC-SFS2024G1H	2.0	1/17	43.7	35

(Note 1)[Unit: mm]

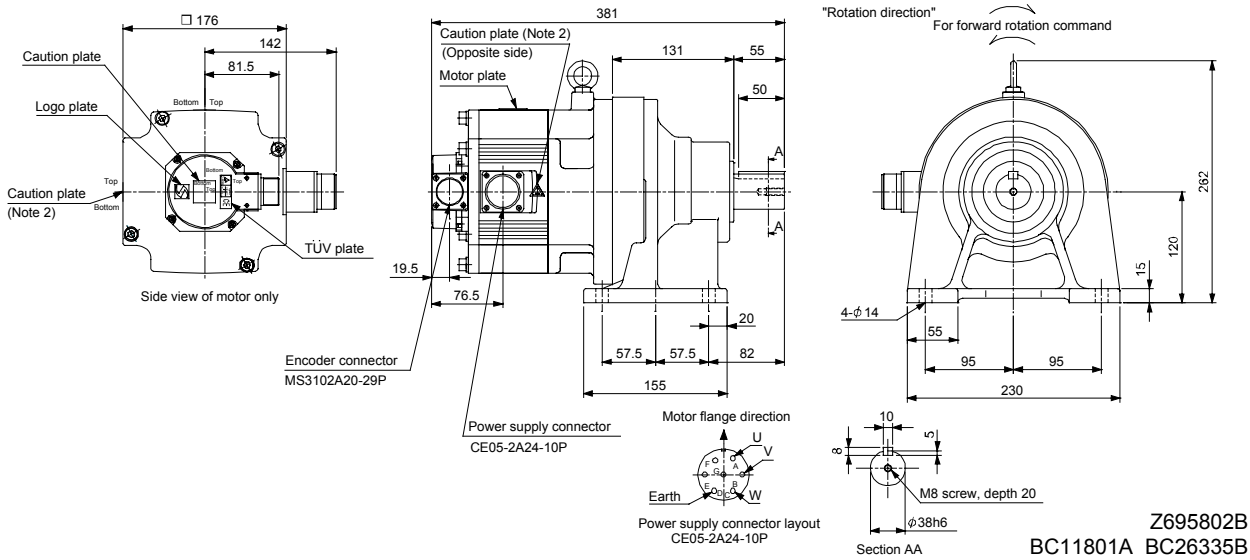

Note 1. The dimensions without tolerances are reference dimensions.
2. This caution plate is attached to the 400V class motors only, not to the 200V class.

Model	Output [kW]	Reduction Ratio	Inertia Moment $J[\times 10^{-4} \text{ kg} \cdot \text{m}^2]$	Mass [kg]
HC-SF352G1H HC-SFS352G1H HC-SFS3524G1H	3.5	1/6	90.1	60
HC-SF352G1H HC-SFS352G1H HC-SFS3524 G1H	3.5	1/11	86.2	60
HC-SF352G1H HC-SFS352G1H HC-SFS3524 G1H	3.5	1/17	85.0	60

(Note)[Unit: mm]

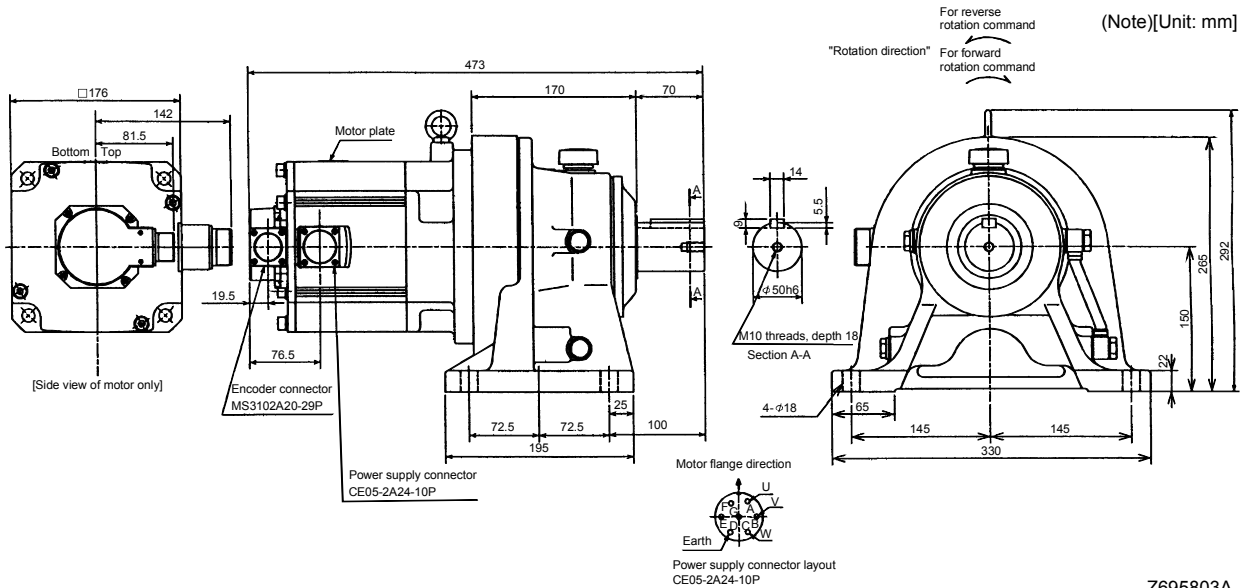

Note: The dimensions without tolerances are reference dimensions.

7. OUTLINE DIMENSION DRAWINGS

Model		Output [kW]	Reduction Ratio	Inertia Moment $J[\times 10^{-4} \text{ kg} \cdot \text{m}^2]$	Variable Dimensions	Mass [kg]
					L	
HC-SF202G1H	HC-SFS202G1H HC-SFS2024G1H	2.0	1/29	48.9	498	91
HC-SF202G1H	HC-SFS202G1H HC-SFS2024G1H	2.0	1/35	48.6	498	91
HC-SF202G1H	HC-SFS202G1H HC-SFS2024G1H	2.0	1/43	48.4	498	91
HC-SF202G1H	HC-SFS202G1H HC-SFS2024G1H	2.0	1/59	48.3	498	91
HC-SF352G1H	HC-SFS352G1H HC-SFS3524G1H	3.5	1/29	88.4	540	98
HC-SF352G1H	HC-SFS352G1H HC-SFS3524G1H	3.5	1/35	88.1	540	98

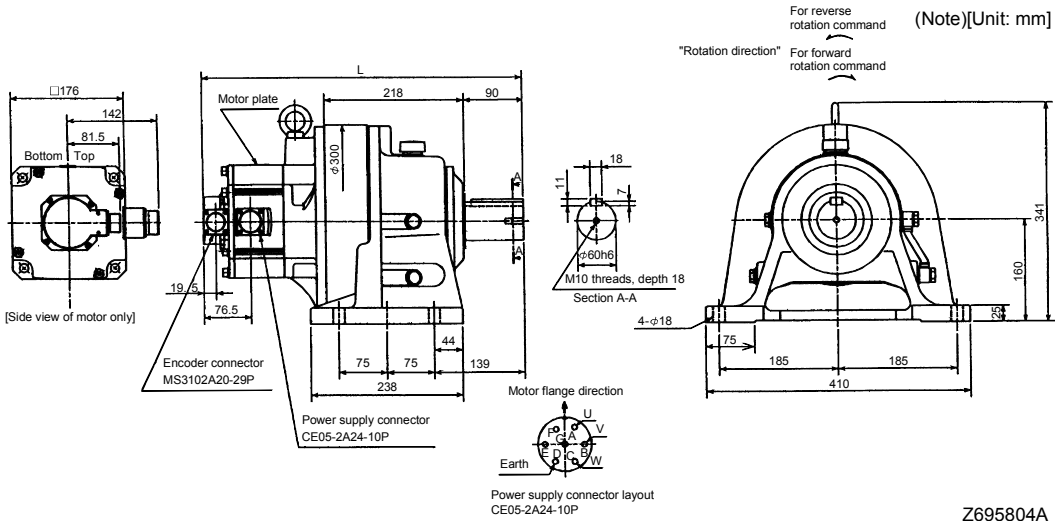

Note: The dimensions without tolerances are reference dimensions.

Model		Output [kW]	Reduction Ratio	Inertia Moment $J[\times 10^{-4} \text{ kg} \cdot \text{m}^2]$	Mass [kg]
HC-SF352G1H	HC-SFS352G1H HC-SFS3524G1H				
HC-SF352G1H	HC-SFS352G1H HC-SFS3524G1H	3.5	1/59	105.9	139

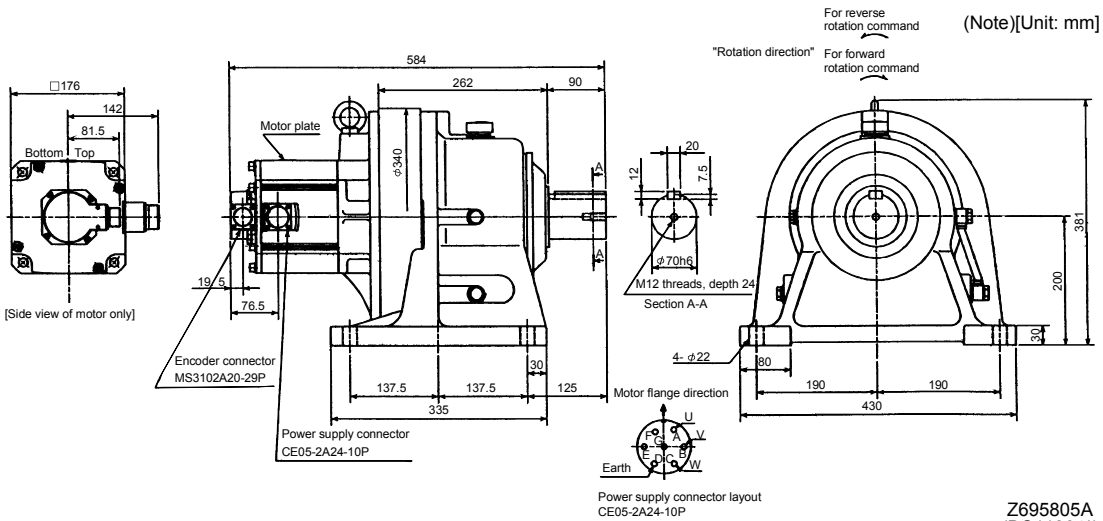

Note: The dimensions without tolerances are reference dimensions.

7. OUTLINE DIMENSION DRAWINGS

Model		Output [kW]	Reduction Ratio	Inertia Moment $J[\times 10^{-4} \text{ kg} \cdot \text{m}^2]$	Mass [kg]
HC-SF502G1H	HC-SFS502G1H	5.0	1/11	113.4	102
	HC-SFS5024G1H				
HC-SF502G1H	HC-SFS502G1H	5.0	1/17	109.4	102
	HC-SFS5024G1H				

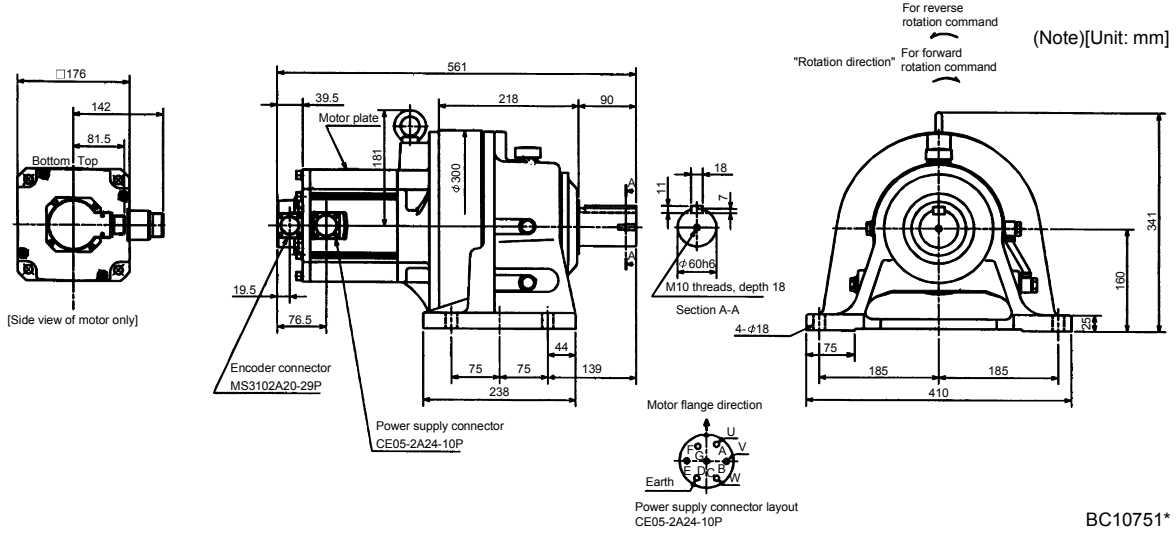

Note: The dimensions without tolerances are reference dimensions.

Model		Output [kW]	Reduction Ratio	Inertia Moment $J[\times 10^{-4} \text{ kg} \cdot \text{m}^2]$	Mass [kg]
HC-SF502G1H	HC-SFS502G1H	5.0	1/29	138.5	171
	HC-SFS5024G1H				
HC-SF502G1H	HC-SFS502G1H	5.0	1/35	138.0	171
	HC-SFS5024G1H				
HC-SF502G1H	HC-SFS502G1H	5.0	1/43	137.0	171
	HC-SFS5024G1H				

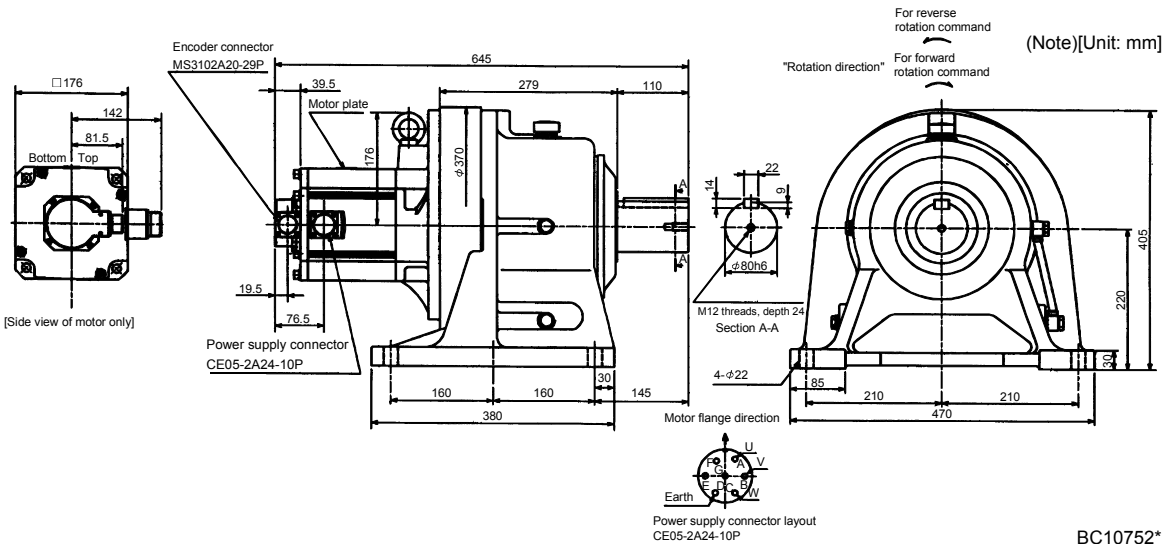

Note: The dimensions without tolerances are reference dimensions.

7. OUTLINE DIMENSION DRAWINGS

Model		Output [kW]	Reduction Ratio	Inertia Moment $J[\times 10^{-4} \text{ kg} \cdot \text{m}^2]$	Mass [kg]
HC-SF702G1H	HC-SFS702G1H HC-SFS7024G1H	7.0	1/11	198.8	138
HC-SF702G1H	HC-SFS702G1H HC-SFS7024G1H	7.0	1/17	190.0	138

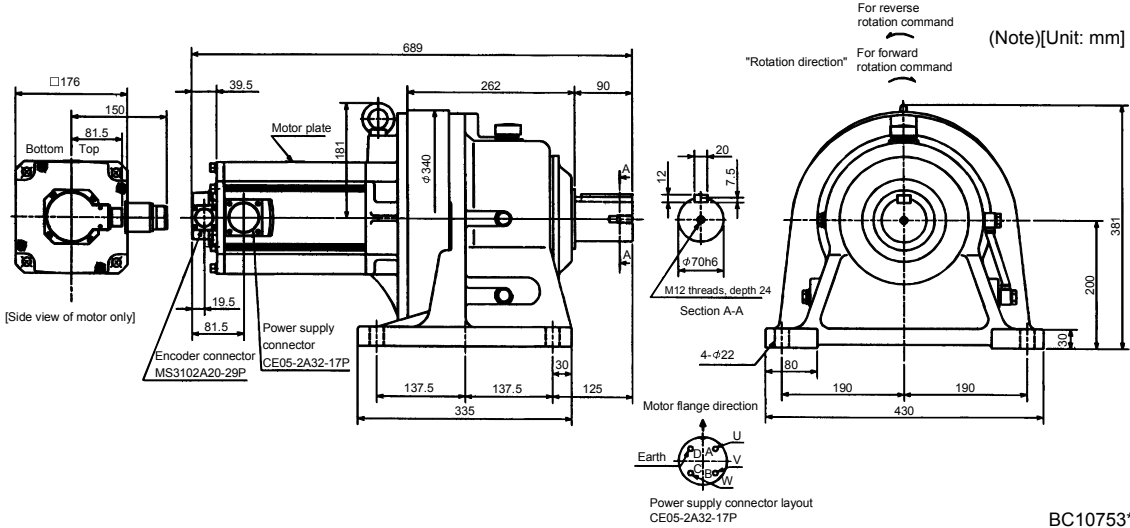

Note: The dimensions without tolerances are reference dimensions.

Model		Output [kW]	Reduction Ratio	Inertia Moment $J[\times 10^{-4} \text{ kg} \cdot \text{m}^2]$	Mass [kg]
HC-SF702G1H	HC-SFS702G1H HC-SFS7024G1H	7.0	1/29	197.5	180
HC-SF702G1H	HC-SFS702G1H HC-SFS7024G1H	7.0	1/35	197.0	180

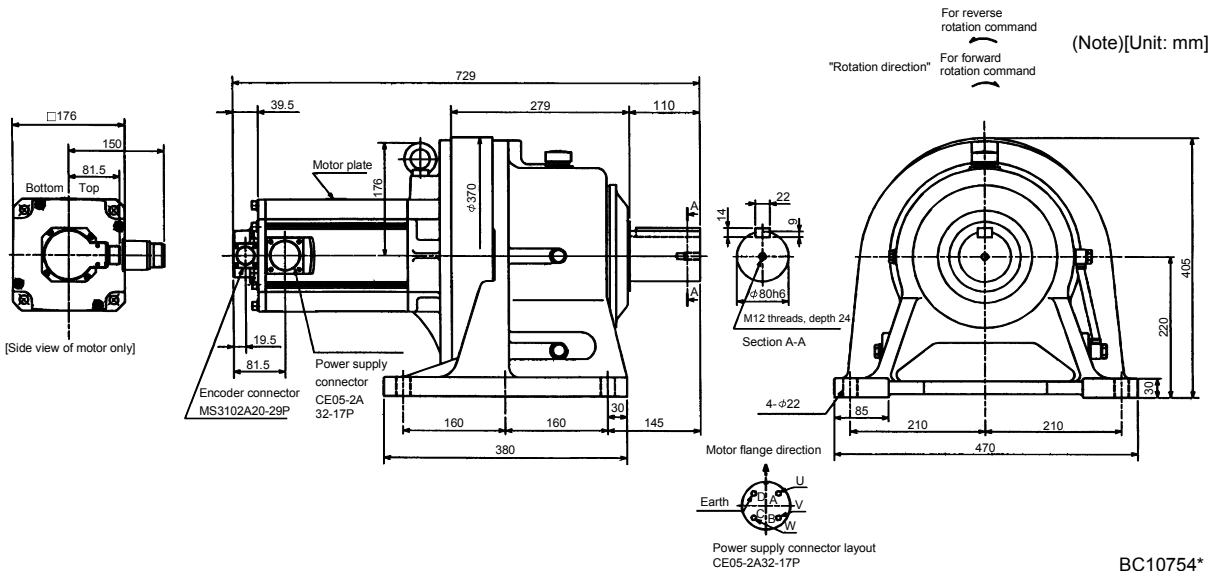

Note: The dimensions without tolerances are reference dimensions.

7. OUTLINE DIMENSION DRAWINGS

Model	Output [kW]	Reduction Ratio	Inertia Moment $J[\times 10^{-4} \text{ kg} \cdot \text{m}^2]$	Mass [kg]
HC-SF702G1H HC-SFS702G1H HC-SF7024G1H HC-SFS7024G1H	7.0	1/43	256.8	261

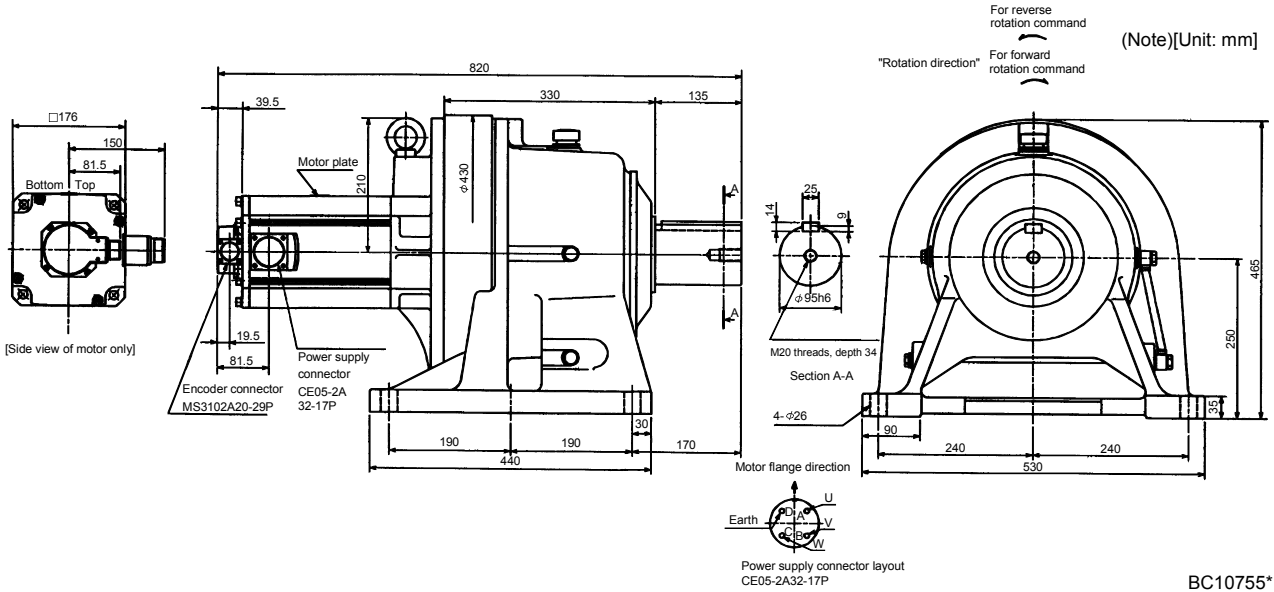

Note: The dimensions without tolerances are reference dimensions.

7. OUTLINE DIMENSION DRAWINGS

(b) With electromagnetic brake

Model			Output [kW]	Reduction Ratio	Inertia Moment $J[\times 10^{-4} \text{kg} \cdot \text{m}^2]$	Variable Dimensions	Mass [kg]	Brake static friction torque [N · m]
						L		
HC-SF52BG1H	HC-SFS52BG1H	HC-SFS524BG1H	0.5	1/35	9.2	371	33	8.3
HC-SF52BG1H	HC-SFS52BG1H	HC-SFS524BG1H	0.5	1/43	9.15	371	33	8.3
HC-SF52BG1H	HC-SFS52BG1H	HC-SFS524BG1H	0.5	1/59	9.13	371	33	8.3
HC-SF102BG1H	HC-SFS102BG1H	HC-SFS1024BG1H	1.0	1/6	18.5	396	35	8.3
HC-SF102BG1H	HC-SFS102BG1H	HC-SFS1024BG1H	1.0	1/11	17.0	396	35	8.3
HC-SF102BG1H	HC-SFS102BG1H	HC-SFS1024BG1H	1.0	1/17	16.6	396	35	8.3
HC-SF102BG1H	HC-SFS102BG1H	HC-SFS1024BG1H	1.0	1/29	16.3	396	35	8.3
HC-SF102BG1H	HC-SFS102BG1H	HC-SFS1024BG1H	1.0	1/35	16.3	396	35	8.3
HC-SF152BG1H	HC-SFS152BG1H	HC-SFS1524BG1H	1.5	1/6	24.8	421	37	8.3
HC-SF152BG1H	HC-SFS152BG1H	HC-SFS1524BG1H	1.5	1/11	23.2	421	37	8.3
HC-SF152BG1H	HC-SFS152BG1H	HC-SFS1524BG1H	1.5	1/17	22.9	421	37	8.3

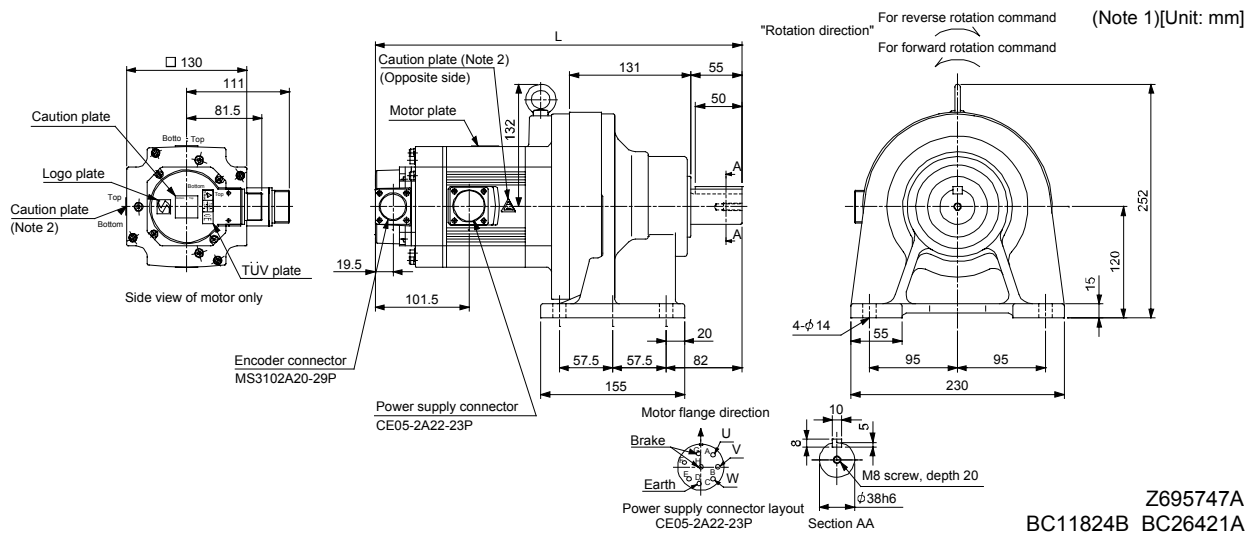

Note 1. The dimensions without tolerances are reference dimensions.
2. This caution plate is attached to the 400V class motors only, not to the 200V class.

Model			Output [kW]	Reduction Ratio	Inertia Moment $J[\times 10^{-4} \text{kg} \cdot \text{m}^2]$	Mass [kg]	Brake static friction torque [N · m]
HC-SF52BG1H	HC-SFS52BG1H	HC-SFS524BG1H					
HC-SF52BG1H	HC-SFS52BG1H	HC-SFS524BG1H	0.5	1/11	8.65	23	8.3
HC-SF52BG1H	HC-SFS52BG1H	HC-SFS524BG1H	0.5	1/17	8.55	23	8.3
HC-SF52BG1H	HC-SFS52BG1H	HC-SFS524BG1H	0.5	1/29	8.48	23	8.3

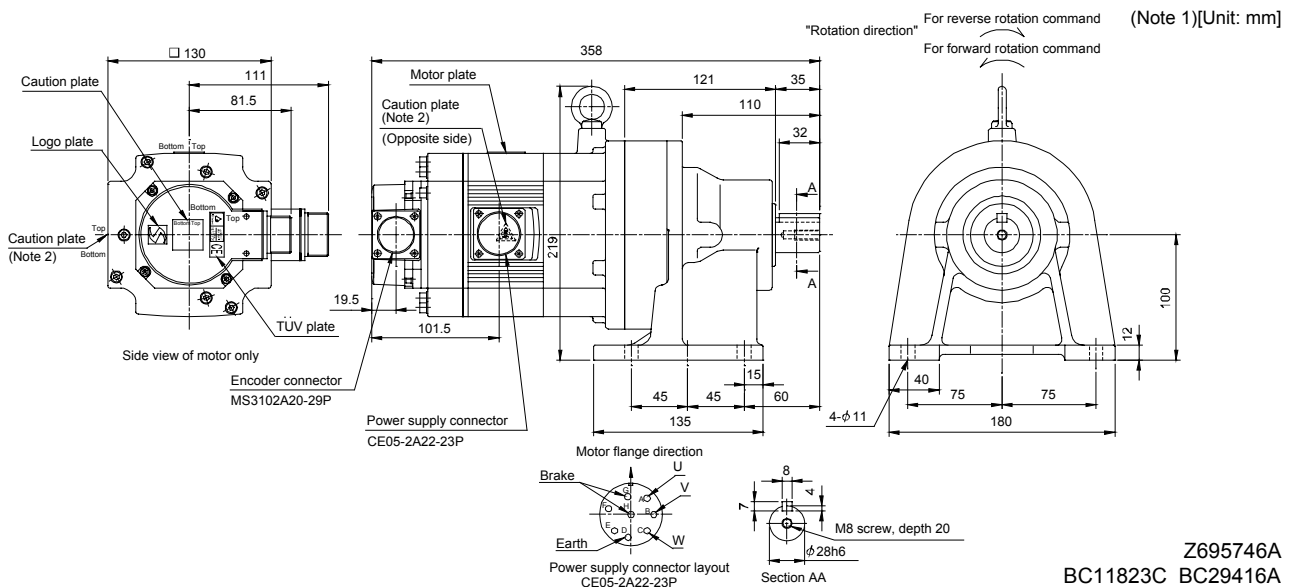

Note 1. The dimensions without tolerances are reference dimensions.
2. This caution plate is attached to the 400V class motors only, not to the 200V class.

7. OUTLINE DIMENSION DRAWINGS

Model		Output [kW]	Reduction Ratio	Inertia Moment J [$\times 10^{-4}$ kg · m ²]	Variable Dimensions	Mass [kg]	Brake static friction torque [N · m]
					L		
HC-SF102BG1H	HC-SFS102BG1H HC-SFS1024BG1H	1.0	1/59	21.18	521	92	8.3
HC-SF152BG1H	HC-SFS152BG1H HC-SFS1524BG1H	1.5	1/43	27.5	546	94	8.3
HC-SF152BG1H	HC-SFS152BG1H HC-SFS1524BG1H	1.5	1/59	27.43	546	94	8.3

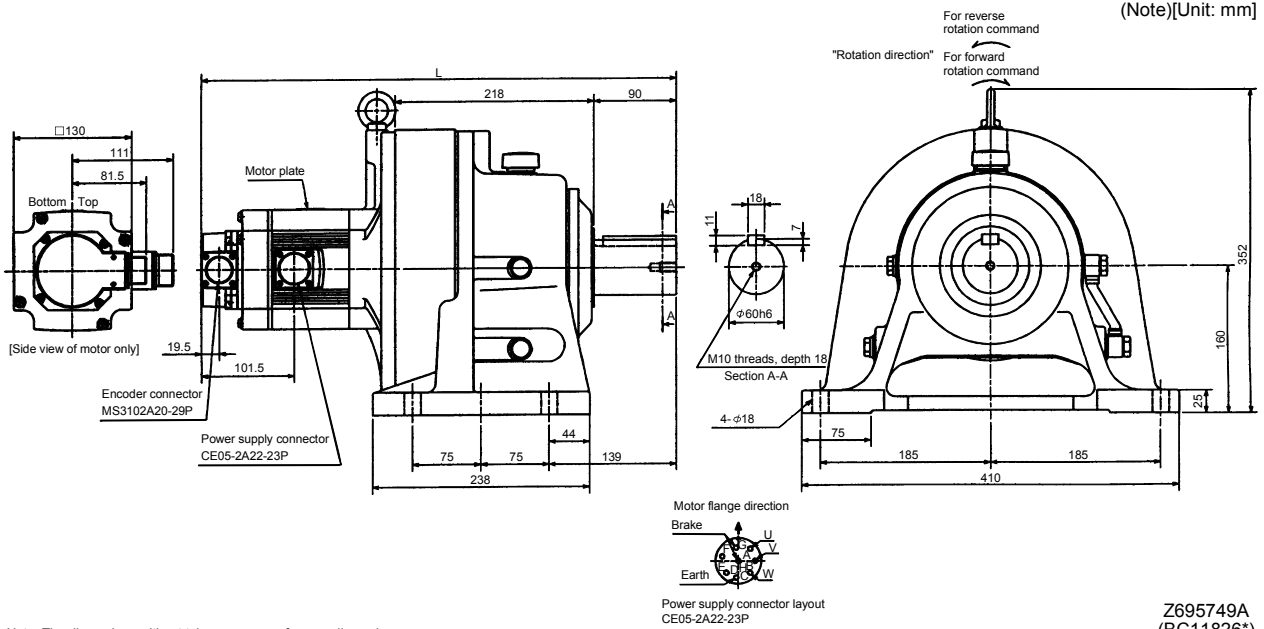

Note: The dimensions without tolerances are reference dimensions.

Z695749A
(BC11826*)

Model		Output [kW]	Reduction Ratio	Inertia Moment J [$\times 10^{-4}$ kg · m ²]	Variable Dimensions	Mass [kg]	Brake static friction torque [N · m]
					L		
HC-SF102BG1H	HC-SFS102BG1H HC-SFS1024BG1H	1.0	1/43	17.35	449	53	8.3
HC-SF152BG1H	HC-SFS152BG1H HC-SFS1524BG1H	1.5	1/29	23.78	474	55	8.3
HC-SF152BG1H	HC-SFS152BG1H HC-SFS1524BG1H	1.5	1/35	23.73	474	55	8.3

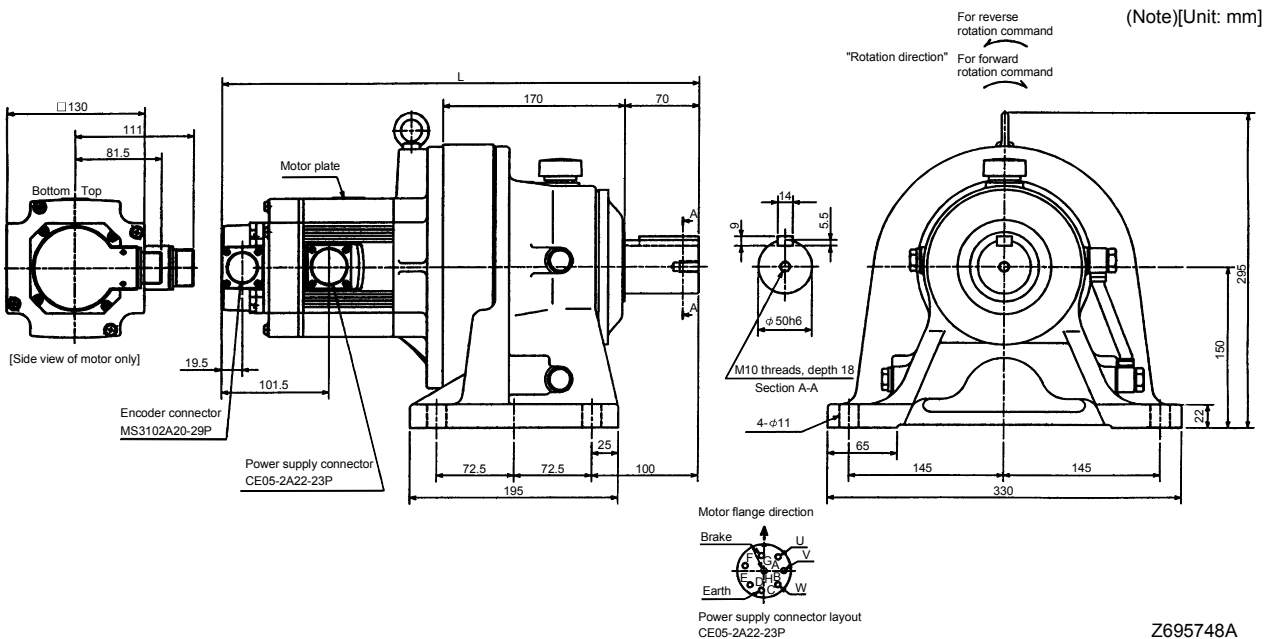

Note: The dimensions without tolerances are reference dimensions.

Z695748A
(BC11825*)

7. OUTLINE DIMENSION DRAWINGS

Model	Output [kW]	Reduction Ratio	Inertia Moment $J[\times 10^{-4} \text{ kg} \cdot \text{m}^2]$	Mass [kg]	Brake static friction torque [N · m]
HC-SF202BG1H HC-SFS202BG1H HC-SFS2024BG1H	2.0	1/6	55.6	41	43.1
HC-SF202BG1H HC-SFS202BG1H HC-SFS2024BG1H	2.0	1/11	54.1	41	43.1
HC-SF202BG1H HC-SFS202BG1H HC-SFS2024BG1H	2.0	1/17	53.7	41	43.1

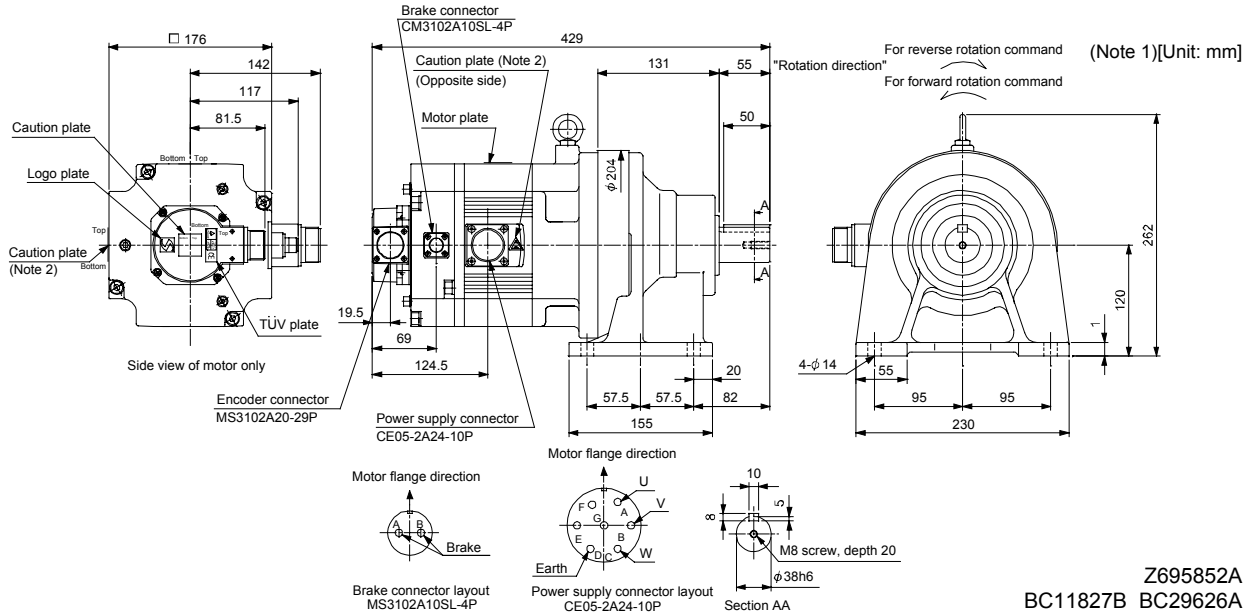

Note 1. The dimensions without tolerances are reference dimensions.
 Note 2. This caution plate is attached to the 400V class motors only, not to the 200V class.

Model	Output [kW]	Reduction Ratio	Inertia Moment $J[\times 10^{-4} \text{ kg} \cdot \text{m}^2]$	Mass [kg]	Brake static friction torque [N · m]
HC-SF352BG1H HC-SFS352BG1H HC-SFS3524BG1H	3.5	1/6	100.1	66	43.1
HC-SF352BG1H HC-SFS352BG1H HC-SFS3524BG1H	3.5	1/11	96.2	66	43.1
HC-SF352BG1H HC-SFS352BG1H HC-SFS3524BG1H	3.5	1/17	95.0	66	43.1

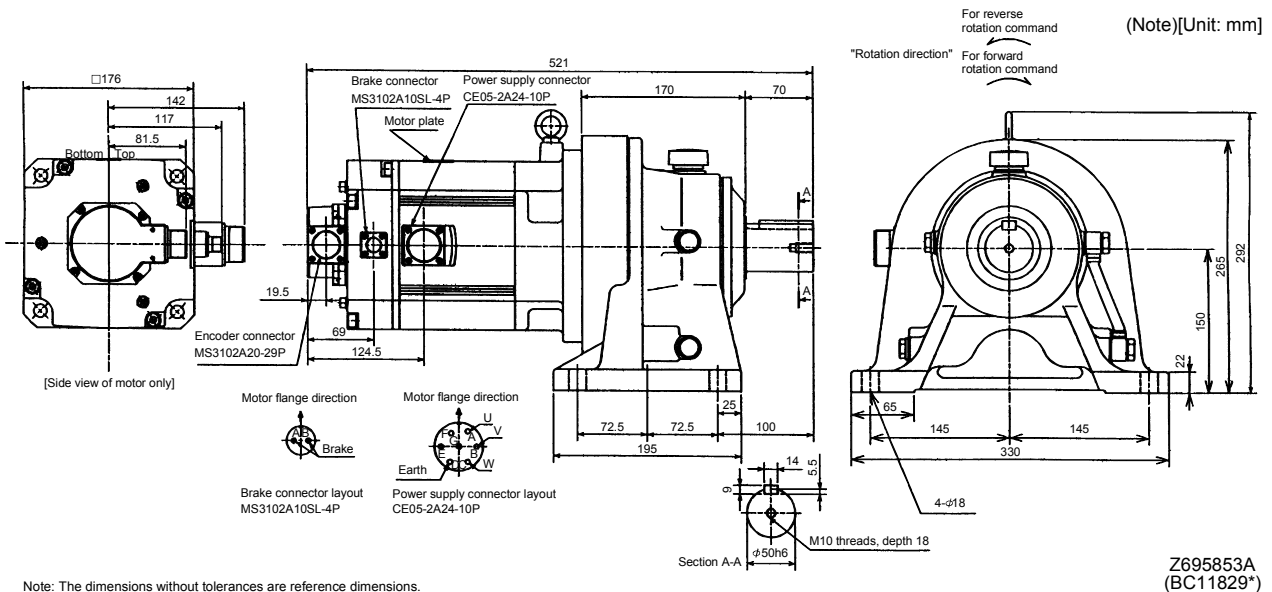

Note: The dimensions without tolerances are reference dimensions.

7. OUTLINE DIMENSION DRAWINGS

Model		Output [kW]	Reduction Ratio	Inertia Moment $J[\times 10^{-4} \text{ kg} \cdot \text{m}^2]$	Variable Dimensions	Mass [kg]	Brake static friction torque [N · m]
					L		
HC-SF202BG1H	HC-SFS202BG1H HC-SFS2024BG1H	2.0	1/29	58.9	546	97	43.1
HC-SF202BG1H	HC-SFS202BG1H HC-SFS2024BG1H	2.0	1/35	58.6	546	97	43.1
HC-SF202BG1H	HC-SFS202BG1H HC-SFS2024BG1H	2.0	1/43	58.4	546	97	43.1
HC-SF202BG1H	HC-SFS202BG1H HC-SFS2024BG1H	2.0	1/59	58.3	546	97	43.1
HC-SF352BG1H	HC-SFS352BG1H HC-SFS3524BG1H	3.5	1/29	98.4	588	104	43.1
HC-SF352BG1H	HC-SFS352BG1H HC-SFS3524BG1H	3.5	1/35	98.1	588	104	43.1

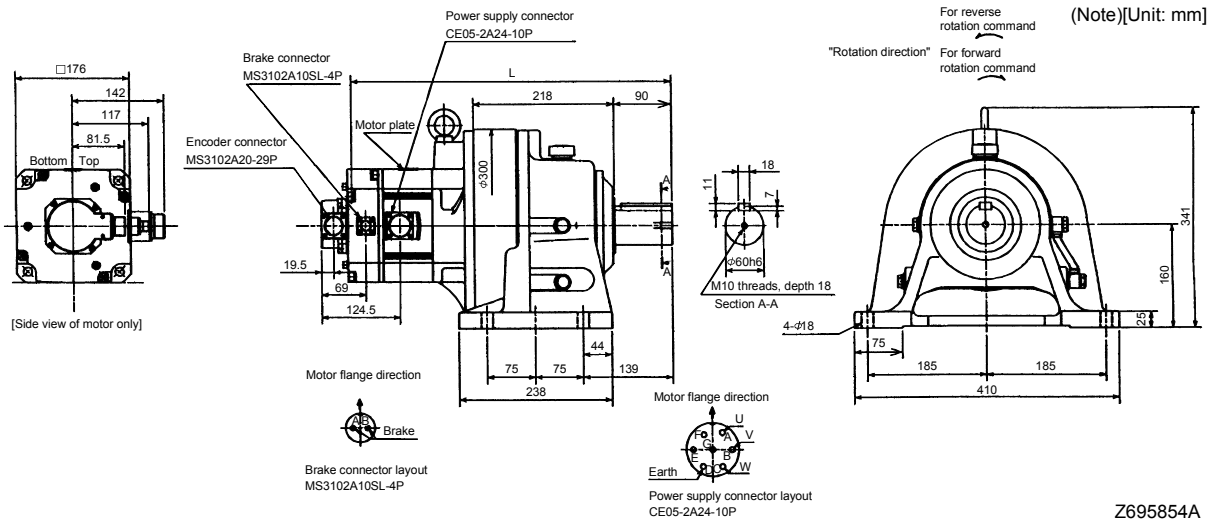

Note: The dimensions without tolerances are reference dimensions.

Model		Output [kW]	Reduction Ratio	Inertia Moment $J[\times 10^{-4} \text{ kg} \cdot \text{m}^2]$	Mass [kg]	Brake static friction torque [N · m]
HC-SF352BG1H	HC-SFS352BG1H HC-SFS3524BG1H	3.5	1/43	116.5	145	43.1
HC-SF352BG1H	HC-SFS352BG1H HC-SFS3524BG1H	3.5	1/59	115.9	145	43.1

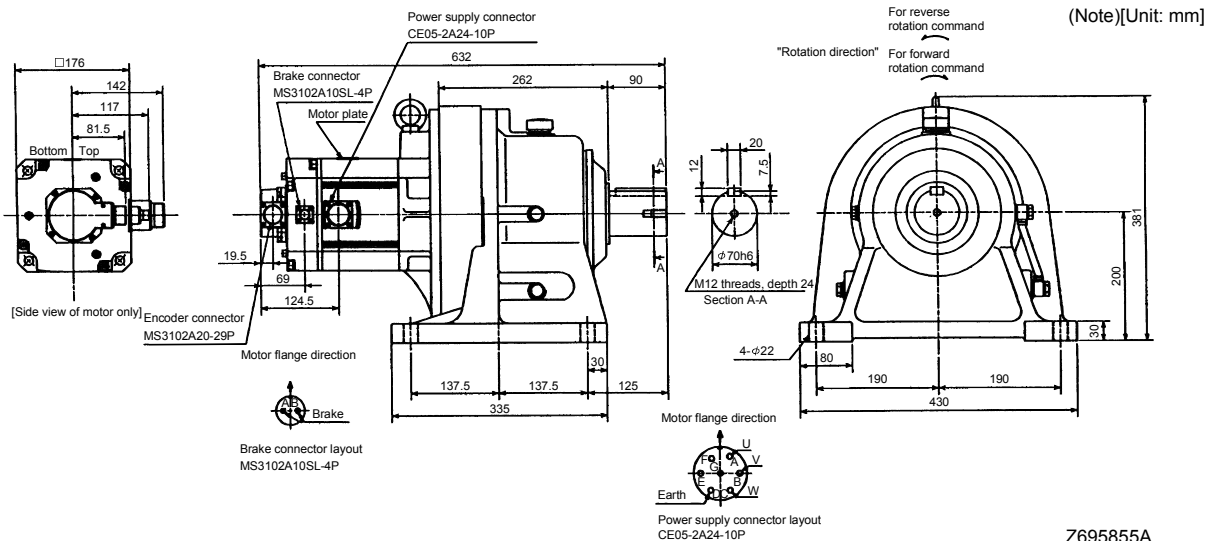

Note: The dimensions without tolerances are reference dimensions.

7. OUTLINE DIMENSION DRAWINGS

Model	Output [kW]	Reduction Ratio	Inertia Moment $J[\times 10^{-4} \text{ kg} \cdot \text{m}^2]$	Mass [kg]	Brake static friction torque [N · m]
HC-SFS502BG1H HC-SFS5024BG1H	5.0	1/11	123.4	108	43.1
HC-SFS502BG1H HC-SFS5024BG1H	5.0	1/17	119.4	108	43.1

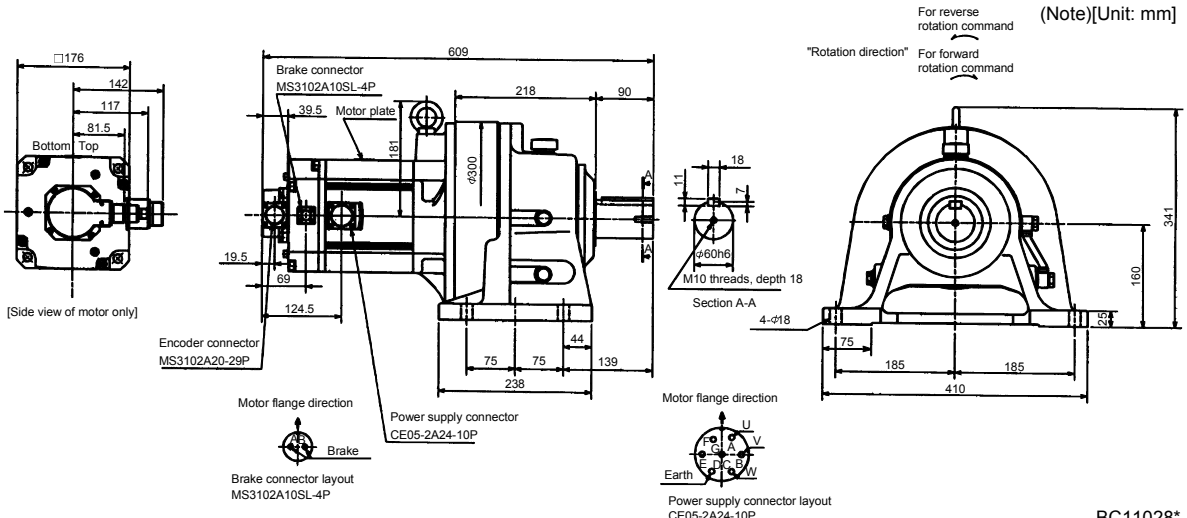

Note: The dimensions without tolerances are reference dimensions.

BC11028*
(BC11831*)

Model	Output [kW]	Reduction Ratio	Inertia Moment $J[\times 10^{-4} \text{ kg} \cdot \text{m}^2]$	Mass [kg]	Brake static friction torque [N · m]
HC-SF502BG1H HC-SFS5024BG1H	5.0	1/29	148.5	177	43.1
HC-SF502BG1H HC-SFS5024BG1H	5.0	1/35	148.0	177	43.1
HC-SF502BG1H HC-SFS5024BG1H	5.0	1/43	147.0	177	43.1

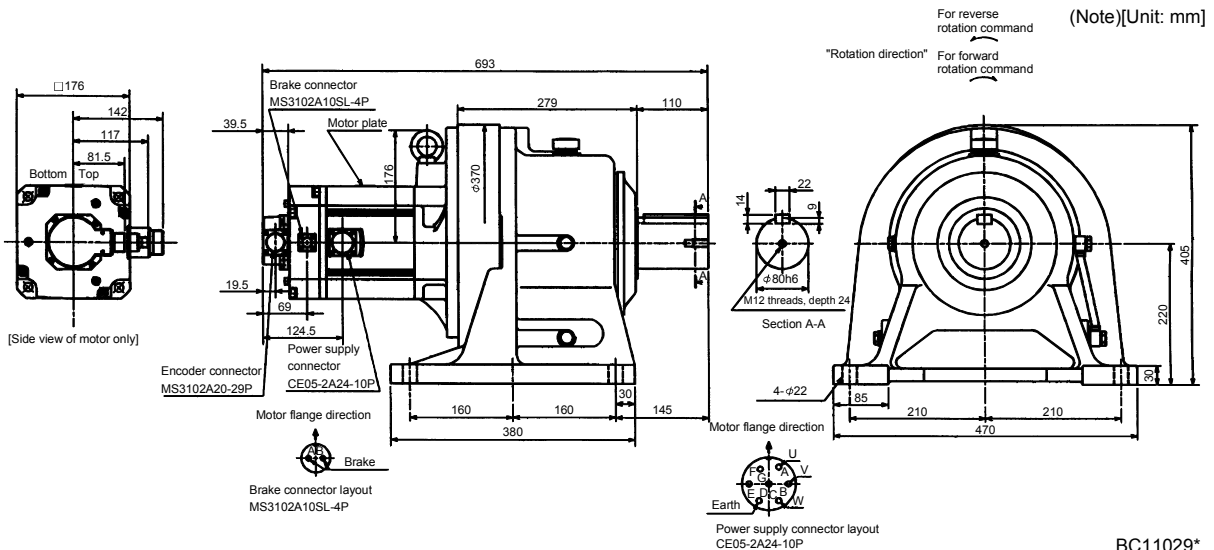

Note: The dimensions without tolerances are reference dimensions.

BC11029*
(BC11832*)

7. OUTLINE DIMENSION DRAWINGS

Model		Output [kW]	Reduction Ratio	Inertia Moment $J[\times 10^{-4} \text{ kg} \cdot \text{m}^2]$	Mass [kg]	Brake static friction torque [N · m]
HC-SF702BG1H	HC-SFS702BG1H HC-SFS7024BG1H	7.0	1/11	208.8	144	43.1
HC-SF702BG1H	HC-SFS702BG1H HC-SFS7024BG1H	7.0	1/17	200.0	144	43.1

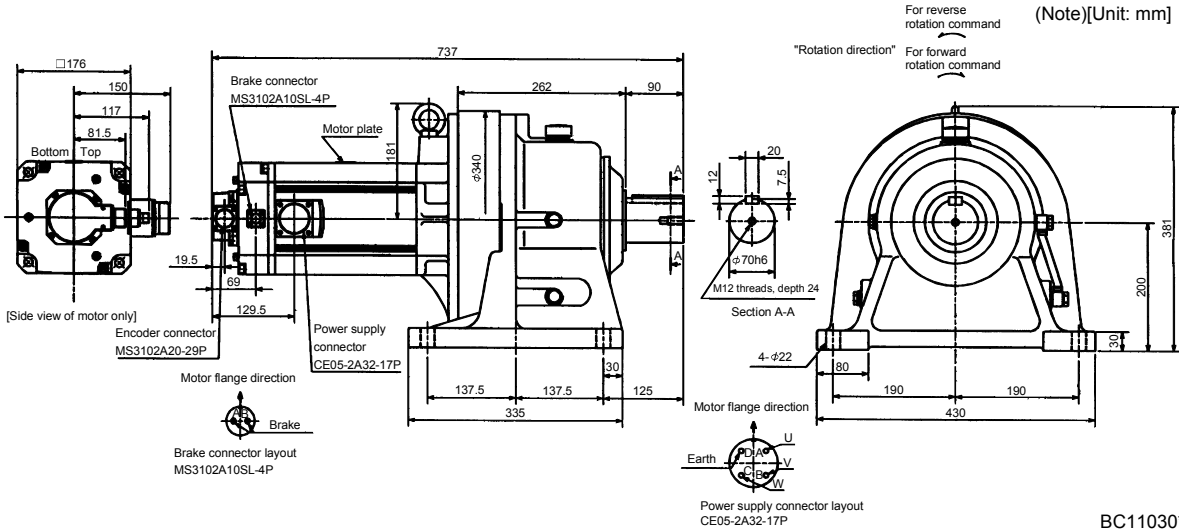

Note: The dimensions without tolerances are reference dimensions.

BC11030*
(BC11833*)

Model		Output [kW]	Reduction Ratio	Inertia Moment $J[\times 10^{-4} \text{ kg} \cdot \text{m}^2]$	Mass [kg]	Brake static friction torque [N · m]
HC-SF702BG1H	HC-SFS702BG1H HC-SFS7024BG1H	7.0	1/29	207.5	186	43.1
HC-SF702BG1H	HC-SFS702BG1H HC-SFS7024BG1H	7.0	1/35	207.0	186	43.1

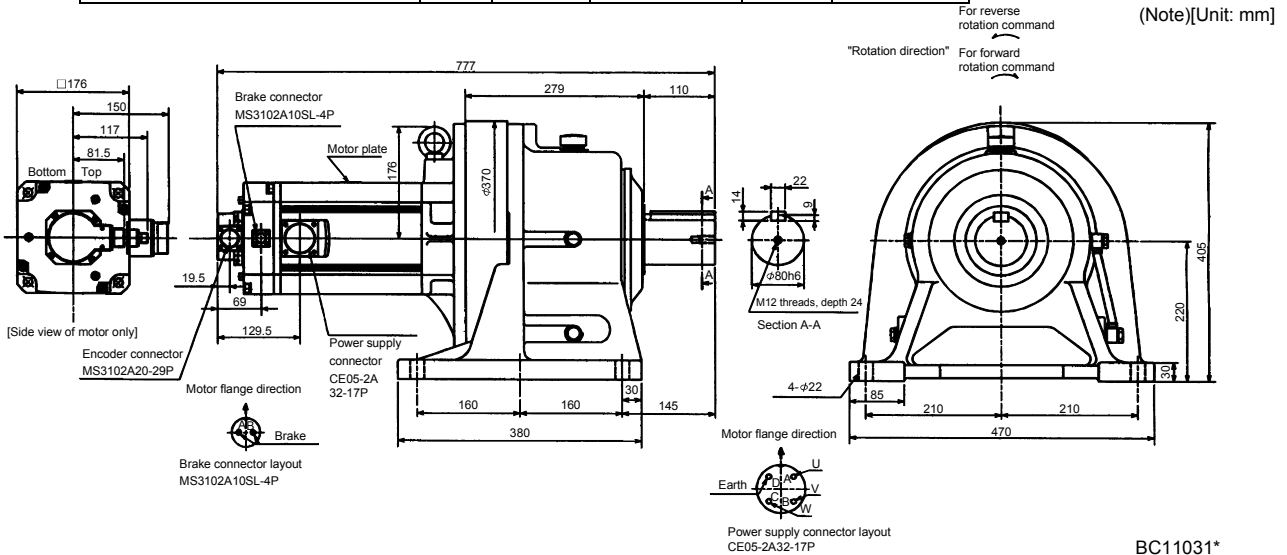

Note: The dimensions without tolerances are reference dimensions.

BC11031*
(BC11834*)

7. OUTLINE DIMENSION DRAWINGS

Model	Output [kW]	Reduction Ratio	Inertia Moment $J[\times 10^{-4} \text{ kg} \cdot \text{m}^2]$	Mass [kg]	Brake static friction torque [N · m]
HC-SF702BG1H HC-SFS702BG1H HC-SFS7024BG1H	7.0	1/43	266.8	267	43.1

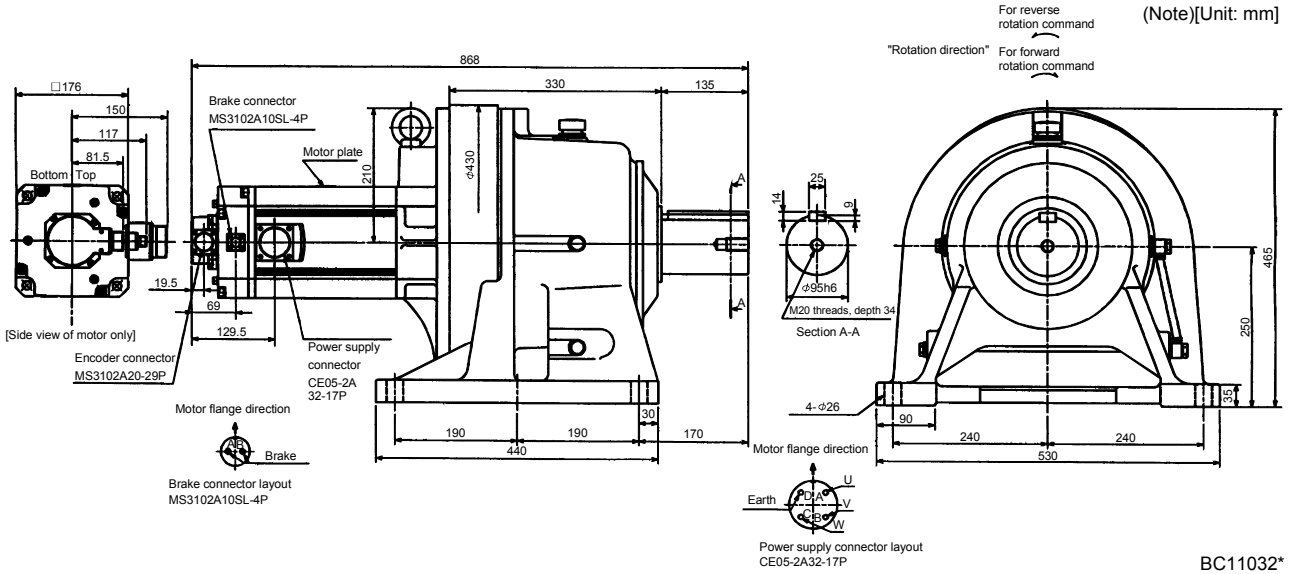

Note: The dimensions without tolerances are reference dimensions.

BC11032*
(BC11835*)

7. OUTLINE DIMENSION DRAWINGS

(4) With reduction gear for general industrial machine (flange type)

The outer frame of the reduction gear is a material surface such as casting. Its actual dimensions may be 1 to 3mm larger than the drawing dimensions. Design the machine side with allowances.

(a) Without electromagnetic brake

Model	Output [kW]	Reduction Ratio	Inertia Moment $J[\times 10^{-4} \text{kg} \cdot \text{m}^2]$	Variable Dimensions	Mass [kg]
				L	
HC-SF52G1 HC-SFS52G1 HC-SFS524G1	0.5	1/35	7.5	269	27
HC-SF52G1 HC-SFS52G1 HC-SFS524G1	0.5	1/43	7.45	269	27
HC-SF52G1 HC-SFS52G1 HC-SFS524G1	0.5	1/59	7.43	269	27
HC-SF102G1 HC-SFS102G1 HC-SFS1024G1	1.0	1/6	16.8	294	29
HC-SF102G1 HC-SFS102G1 HC-SFS1024G1	1.0	1/11	15.3	294	29
HC-SF102G1 HC-SFS102G1 HC-SFS1024G1	1.0	1/17	14.9	294	29
HC-SF102G1 HC-SFS102G1 HC-SFS1024G1	1.0	1/29	14.6	294	29
HC-SF102G1 HC-SFS102G1 HC-SFS1024G1	1.0	1/35	14.6	294	29
HC-SF152G1 HC-SFS152G1 HC-SFS1524G1	1.5	1/6	23.1	319	31
HC-SF152G1 HC-SFS152G1 HC-SFS1524G1	1.5	1/11	21.5	319	31
HC-SF152G1 HC-SFS152G1 HC-SFS1524G1	1.5	1/17	21.2	319	31

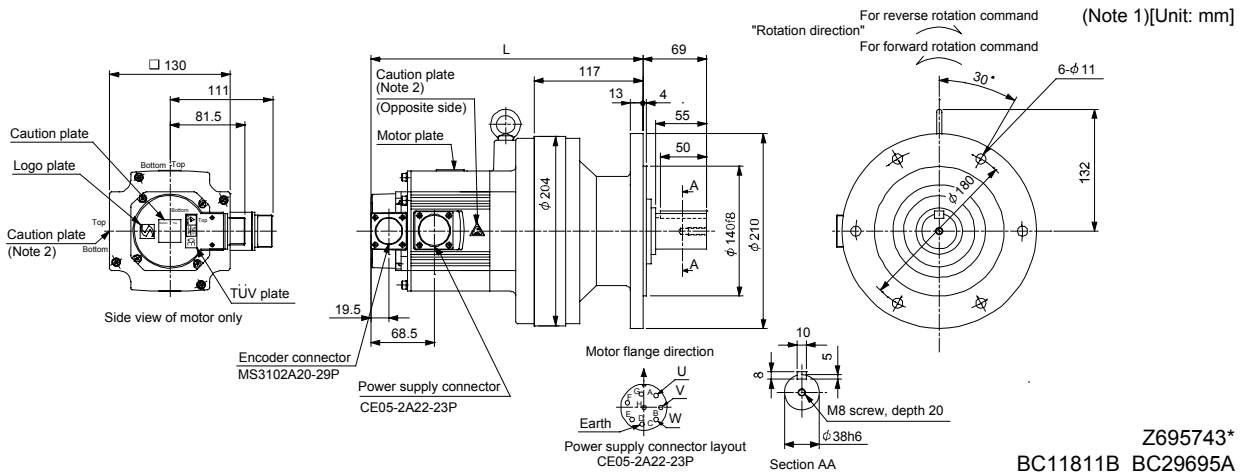

Note 1. The dimensions without tolerances are reference dimensions.
2. This caution plate is attached to the 400V class motors only, not to the 200V class.

Model	Output [kW]	Reduction Ratio	Inertia Moment $J[\times 10^{-4} \text{kg} \cdot \text{m}^2]$	Mass
				[kg]
HC-SF52G1 HC-SFS52G1 HC-SFS524G1	0.5	1/6	7.33	18.5
HC-SF52G1 HC-SFS52G1 HC-SFS524G1	0.5	1/11	6.95	18.5
HC-SF52G1 HC-SFS52G1 HC-SFS524G1	0.5	1/17	6.85	18.5
HC-SF52G1 HC-SFS52G1 HC-SFS524G1	0.5	1/29	6.78	18.5

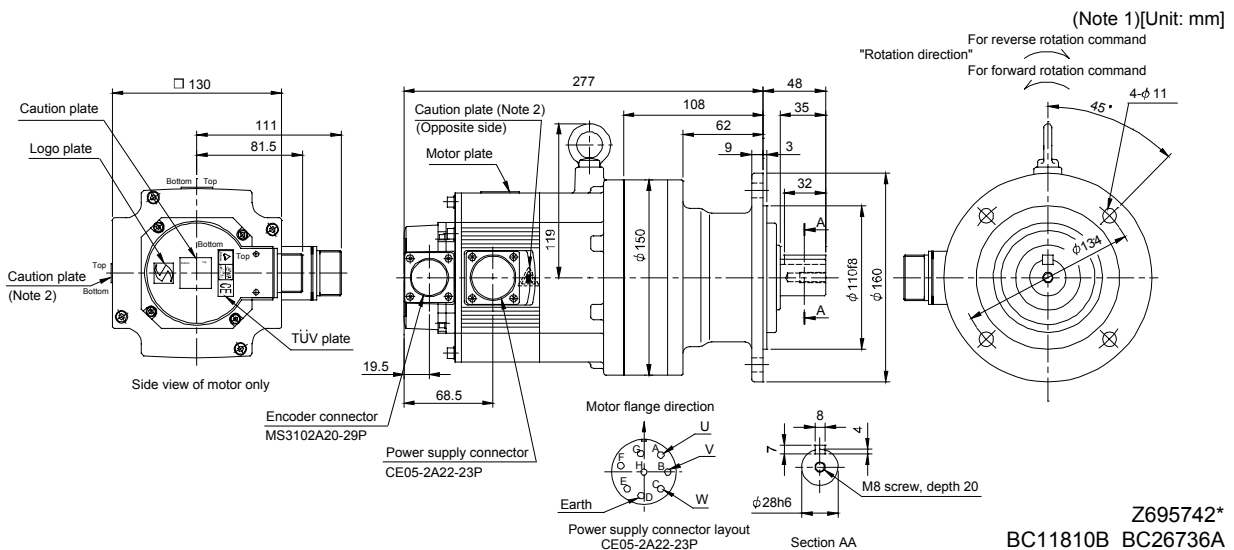

Note 1. The dimensions without tolerances are reference dimensions.
2. This caution plate is attached to the 400V class motors only, not to the 200V class.

7. OUTLINE DIMENSION DRAWINGS

Model		Output [kW]	Reduction Ratio	Inertia Moment J [$\times 10^{-4}$ kg · m ²]	Variable Dimensions	Mass [kg]
					L	
HC-SF102G1	HC-SFS102G1	1.0	1/59	19.5	399	83
	HC-SFS1024G1					
HC-SF152G1	HC-SFS152G1	1.5	1/43	25.8	424	85
	HC-SFS1524G1					
HC-SF152G1	HC-SFS152G1	1.5	1/59	25.7	424	85
	HC-SFS1524G1					

(Note)[Unit: mm]

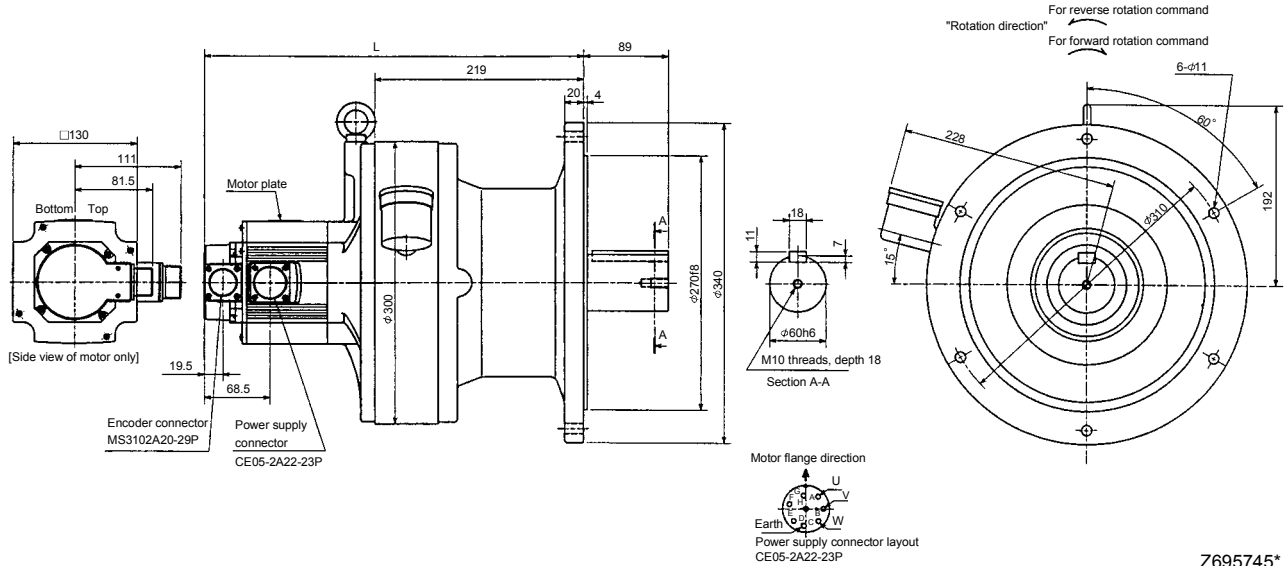

Note: The dimensions without tolerances are reference dimensions.

Z695745*
(BC11813*)

Model		Output [kW]	Reduction Ratio	Inertia Moment J [$\times 10^{-4}$ kg · m ²]	Variable Dimensions	Mass [kg]
					L	
HC-SF102G1	HC-SFS102G1	1.0	1/43	15.7	340	48
	HC-SFS1024G1					
HC-SF152G1	HC-SFS152G1	1.5	1/29	22.1	365	50
	HC-SFS1524G1					
HC-SF152G1	HC-SFS152G1	1.5	1/35	22.0	365	50
	HC-SFS1524G1					

(Note)[Unit: mm]

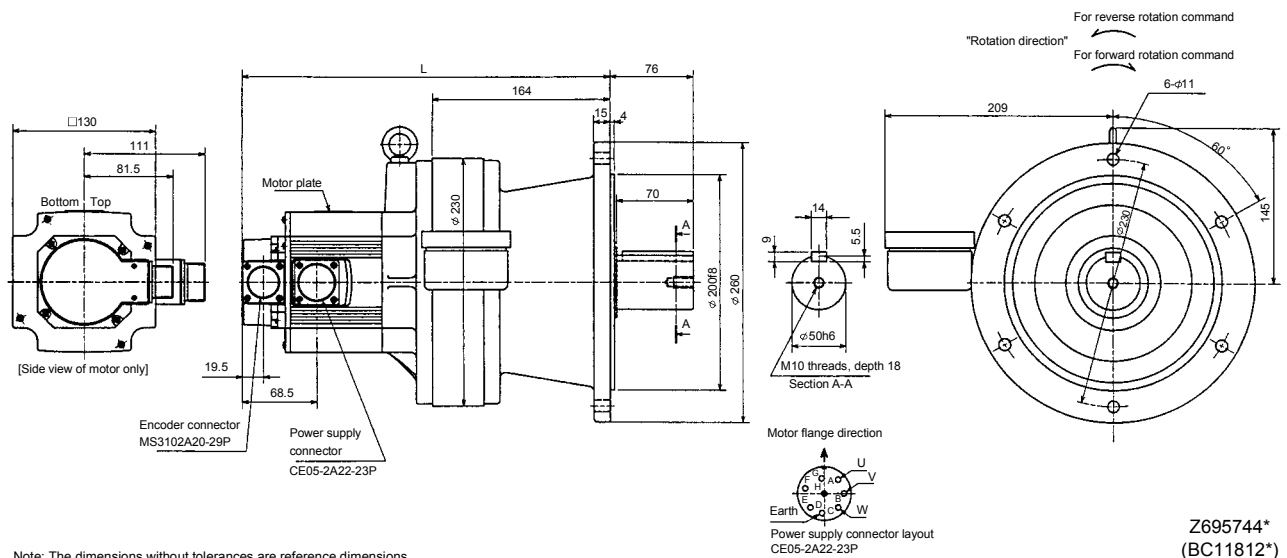

Note: The dimensions without tolerances are reference dimensions.

Z695744*
(BC11812*)

7. OUTLINE DIMENSION DRAWINGS

Model	Output [kW]	Reduction Ratio	Inertia Moment $J[\times 10^{-4} \text{kg} \cdot \text{m}^2]$	Mass [kg]
HC-SF202G1 HC-SFS202G1 HC-SFS2024G1	2.0	1/6	45.6	34
HC-SF202G1 HC-SFS202G1 HC-SFS2024G1	2.0	1/11	44.1	34
HC-SF202G1 HC-SFS202G1 HC-SFS2024G1	2.0	1/17	43.7	34

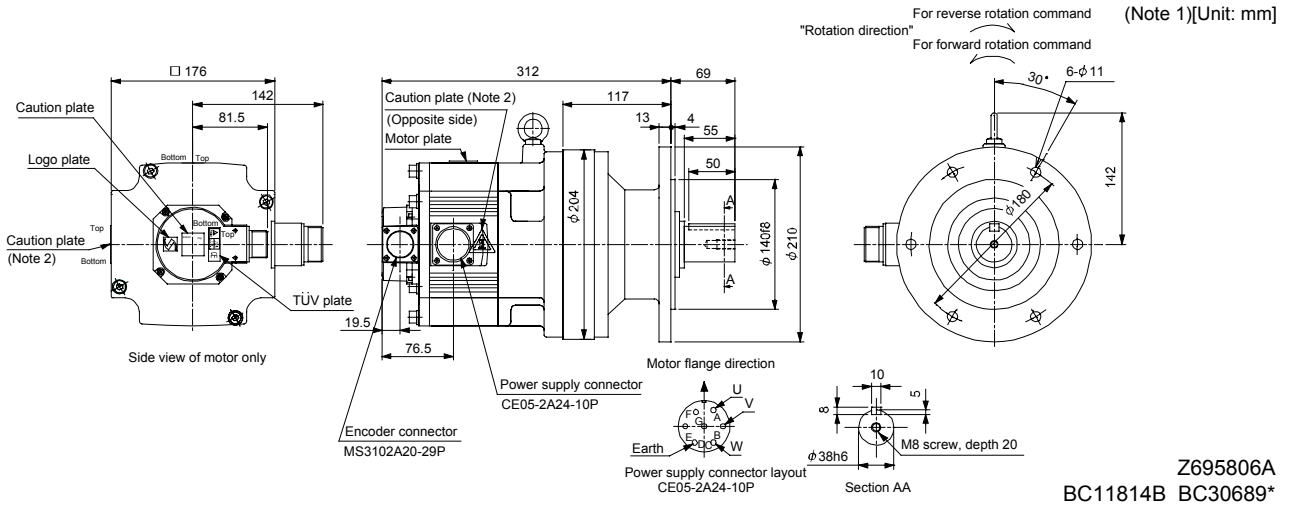

Note 1. The dimensions without tolerances are reference dimensions.
2. This caution plate is attached to the 400V class motors only, not to the 200V class.

Model	Output [kW]	Reduction Ratio	Inertia Moment $J[\times 10^{-4} \text{kg} \cdot \text{m}^2]$	Mass [kg]
HC-SF352G1 HC-SFS352G1 HC-SFS3524G1	3.5	1/6	90.1	57
HC-SF352G1 HC-SFS352G1 HC-SFS3524G1	3.5	1/11	86.2	57
HC-SF352G1 HC-SFS352G1 HC-SFS3524G1	3.5	1/17	85.0	57

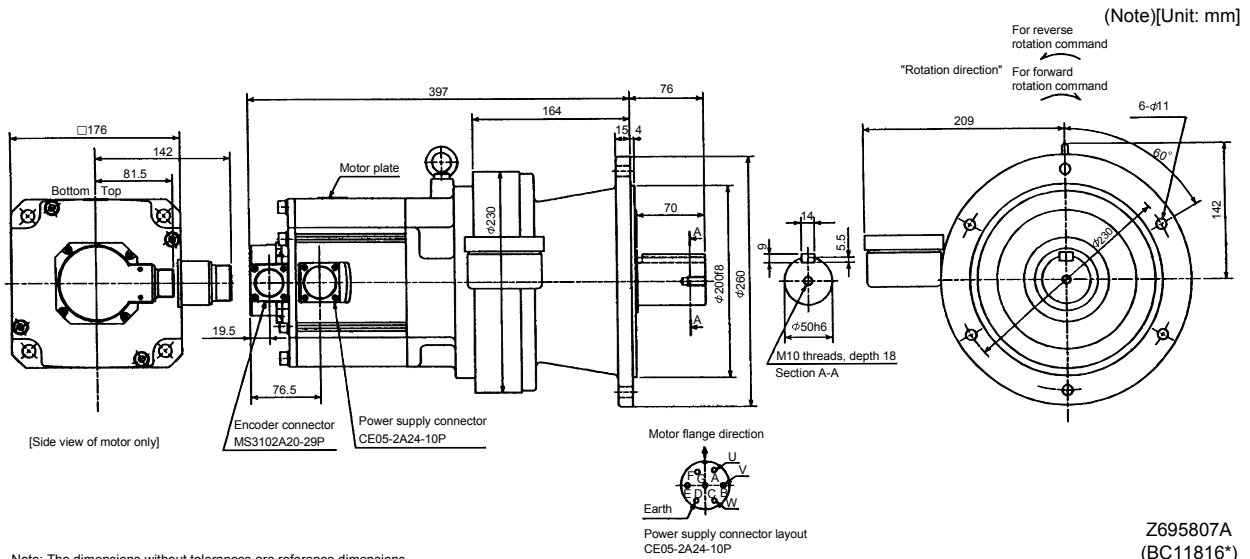

Note: The dimensions without tolerances are reference dimensions.

7. OUTLINE DIMENSION DRAWINGS

Model		Output [kW]	Reduction Ratio	Inertia Moment J [$\times 10^{-4} \text{ kg} \cdot \text{m}^2$]	Variable Dimensions	Mass [kg]
					L	
HC-SF202G1	HC-SFS202G1	2.0	1/29	48.9	409	84
	HC-SFS2024G1					
HC-SF202G1	HC-SFS202G1	2.0	1/35	48.6	409	84
	HC-SFS2024G1					
HC-SF202G1	HC-SFS202G1	2.0	1/43	48.4	409	84
	HC-SFS2024G1					
HC-SF202G1	HC-SFS202G1	2.0	1/59	48.3	409	84
	HC-SFS2024G1					
HC-SF352G1	HC-SFS352G1	3.5	1/29	88.4	451	91
	HC-SFS3524G1					
HC-SF352G1	HC-SFS352G1	3.5	1/35	88.1	451	91
	HC-SFS3524G1					

(Note)[Unit: mm]

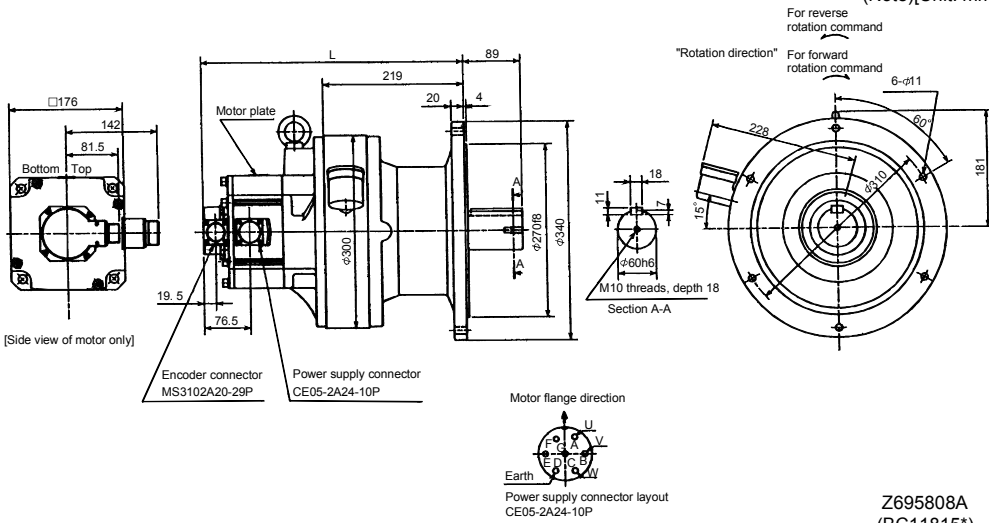

Note: The dimensions without tolerances are reference dimensions.

Z695808A
(BC11815*)

Model		Output [kW]	Reduction Ratio	Inertia Moment J [$\times 10^{-4} \text{ kg} \cdot \text{m}^2$]	Mass [kg]
HC-SF352G1	HC-SFS352G1				
	HC-SFS3524G1				
HC-SF352G1	HC-SFS352G1	3.5	1/59	105.9	133
	HC-SFS3524G1				

(Note)[Unit: mm]

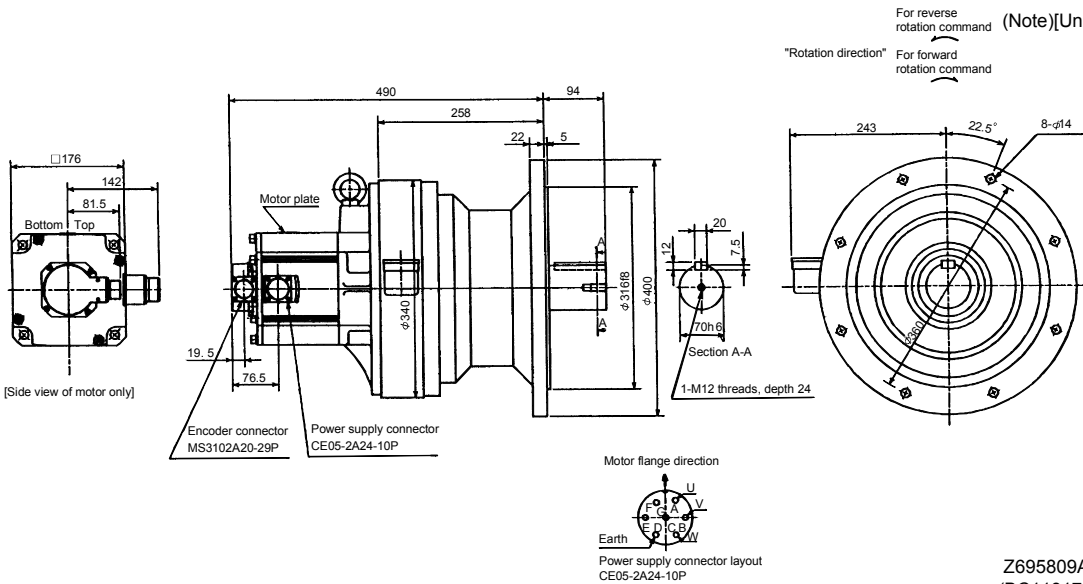

Note: The dimensions without tolerances are reference dimensions.

Z695809A
(BC11817*)

7. OUTLINE DIMENSION DRAWINGS

Model	Output [kW]	Reduction Ratio	Inertia Moment $J[\times 10^{-4} \text{ kg} \cdot \text{m}^2]$	Mass [kg]
HC-SF502G1 HC-SFS502G1 HC-SFS5024G1	5.0	1/11	113.4	95
HC-SF502G1 HC-SFS502G1 HC-SFS5024G1	5.0	1/17	109.4	95

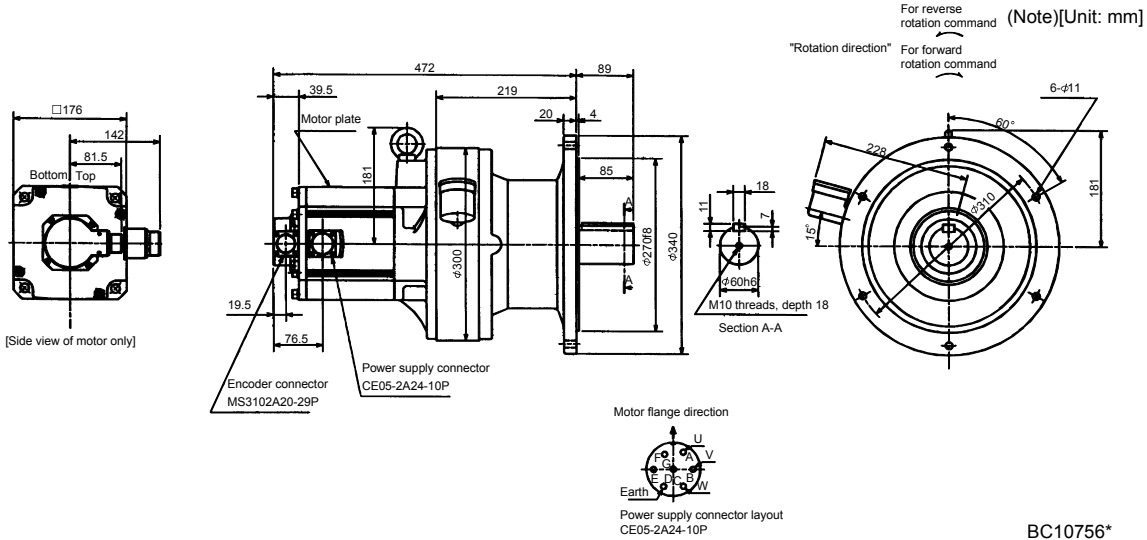

Note: The dimensions without tolerances are reference dimensions.

Model	Output [kW]	Reduction Ratio	Inertia Moment $J[\times 10^{-4} \text{ kg} \cdot \text{m}^2]$	Mass [kg]
HC-SF502G1 HC-SFS502G1 HC-SFS5024G1	5.0	1/29	138.5	162
HC-SF502G1 HC-SFS502G1 HC-SFS5024G1	5.0	1/35	138.0	162
HC-SF502G1 HC-SFS502G1 HC-SFS5024G1	5.0	1/43	137.0	162

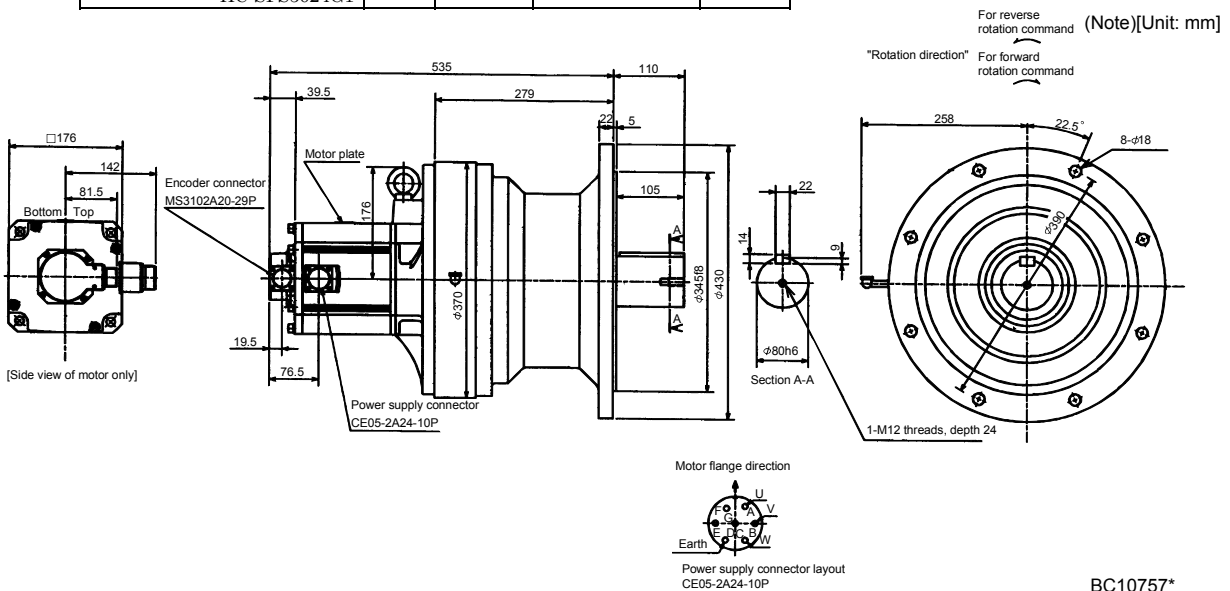

Note: The dimensions without tolerances are reference dimensions.

7. OUTLINE DIMENSION DRAWINGS

Model	Output [kW]	Reduction Ratio	Inertia Moment $J[\times 10^{-4} \text{kg} \cdot \text{m}^2]$	Mass [kg]
HC-SF702G1 HC-SFS702G1 HC-SFS7024G1	7.0	1/11	198.8	146
HC-SF702G1 HC-SFS702G1 HC-SFS7024G1	7.0	1/17	190.0	146

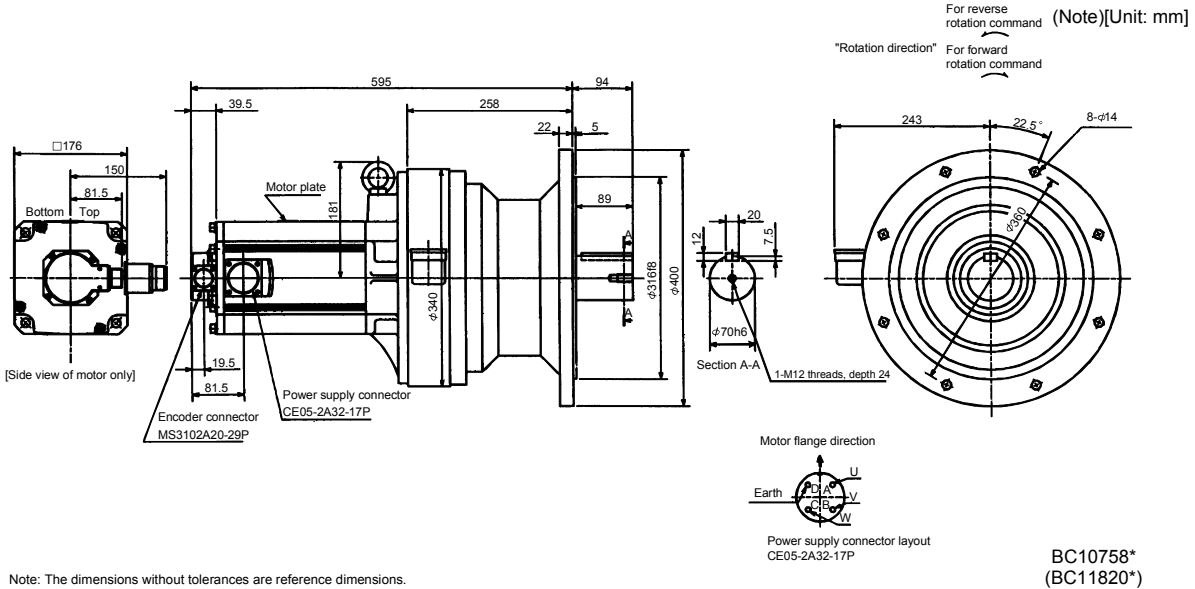

Model	Output [kW]	Reduction Ratio	Inertia Moment $J[\times 10^{-4} \text{kg} \cdot \text{m}^2]$	Mass [kg]
HC-SF702G1 HC-SFS702G1 HC-SFS7024G1	7.0	1/29	197.5	171
HC-SF702G1 HC-SFS702G1 HC-SFS7024G1	7.0	1/35	197.0	171

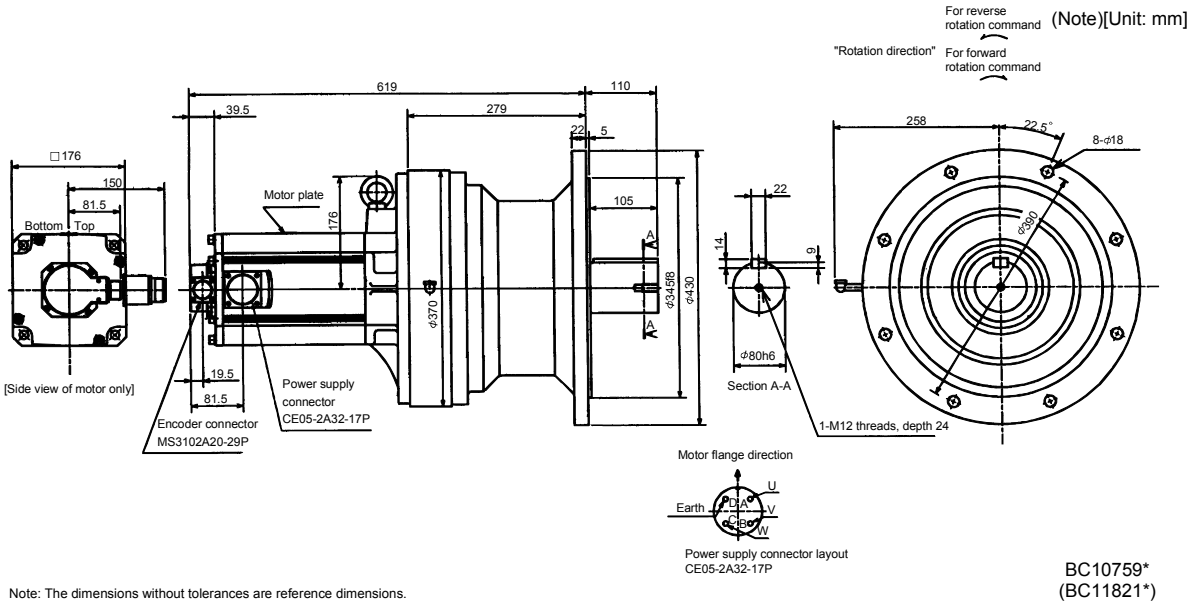

7. OUTLINE DIMENSION DRAWINGS

Model	Output [kW]	Reduction Ratio	Inertia Moment $J[\times 10^{-4} \text{kg} \cdot \text{m}^2]$	Mass [kg]
HC-SF702G1 HC-SFS702G1 HC-SFS7024G1	7.0	1/43	256.8	240

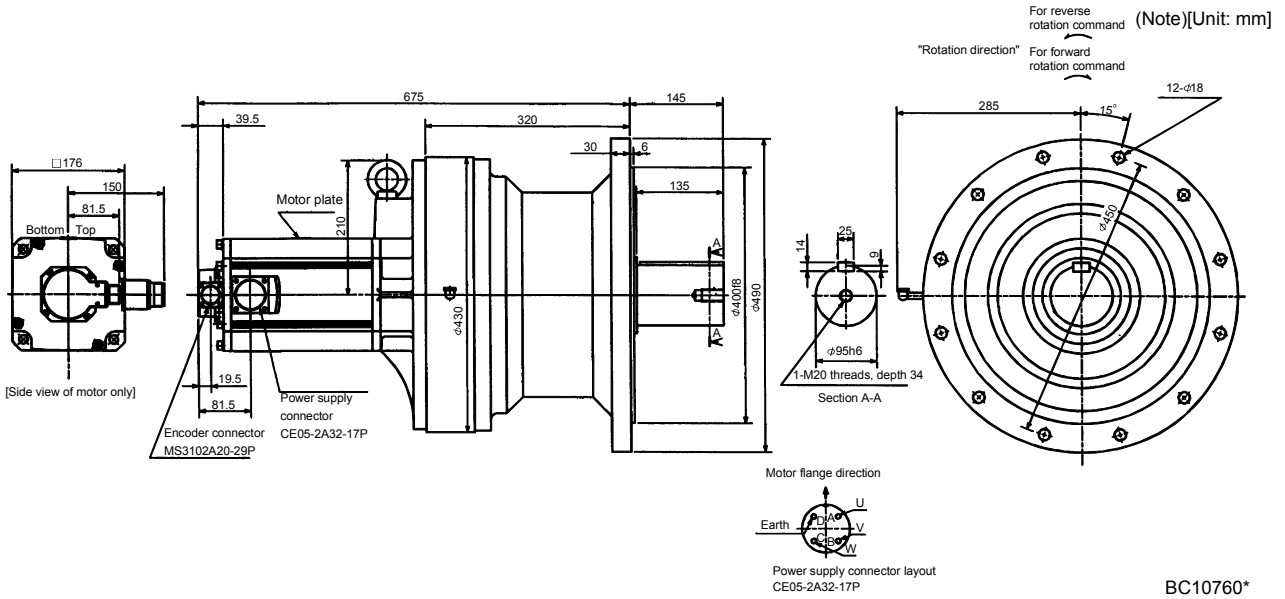

Note: The dimensions without tolerances are reference dimensions.

7. OUTLINE DIMENSION DRAWINGS

(b) With electromagnetic brake

Model			Output [kW]	Reduction Ratio	Inertia Moment $J[\times 10^{-4} \text{ kg} \cdot \text{m}^2]$	Variable Dimensions		Mass [kg]	Brake static friction torque [N · m]
						L			
HC-SF52BG1	HC-SFS52BG1	HC-SFS524BG1	0.5	1/35	9.2	302		32.5	8.3
HC-SF52BG1	HC-SFS52BG1	HC-SFS524BG1	0.5	1/43	9.15	302		32.5	8.3
HC-SF52BG1	HC-SFS52BG1	HC-SFS524BG1	0.5	1/59	9.13	302		32.5	8.3
HC-SF102BG1	HC-SFS102BG1	HC-SFS1024BG1	1.0	1/6	18.5	327		34.5	8.3
HC-SF102BG1	HC-SFS102BG1	HC-SFS1024BG1	1.0	1/11	17.0	327		34.5	8.3
HC-SF102BG1	HC-SFS102BG1	HC-SFS1024BG1	1.0	1/17	16.6	327		34.5	8.3
HC-SF102BG1	HC-SFS102BG1	HC-SFS1024BG1	1.0	1/29	16.3	327		34.5	8.3
HC-SF102BG1	HC-SFS102BG1	HC-SFS1024BG1	1.0	1/35	16.28	327		34.5	8.3
HC-SF152BG1	HC-SFS152BG1	HC-SFS1524BG1	1.5	1/6	24.8	352		36.5	8.3
HC-SF152BG1	HC-SFS152BG1	HC-SFS1524BG1	1.5	1/11	23.2	352		36.5	8.3
HC-SF152BG1	HC-SFS152BG1	HC-SFS1524BG1	1.5	1/17	22.9	352		36.5	8.3

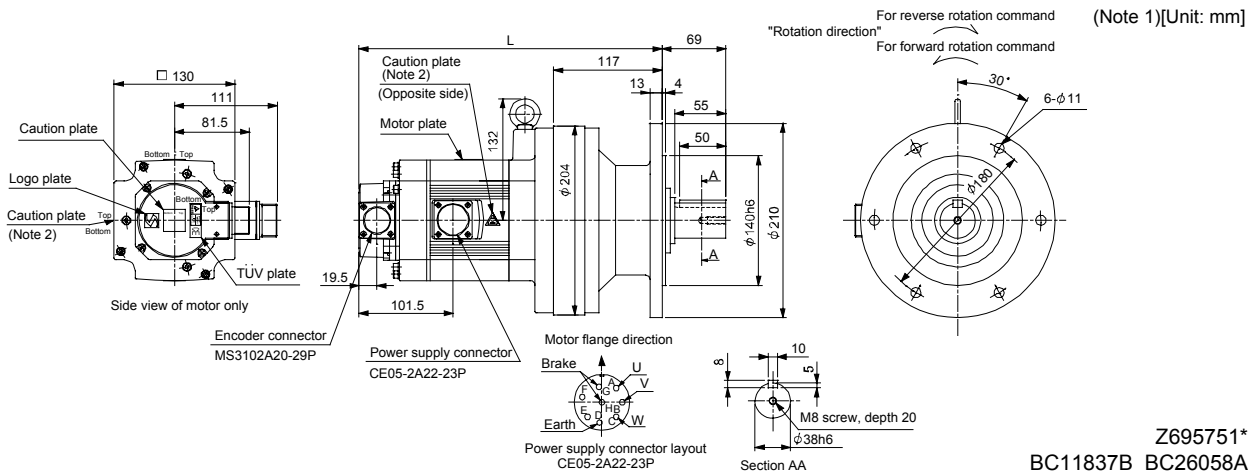

Note 1. The dimensions without tolerances are reference dimensions.
 2. This caution plate is attached to the 400V class motors only, not to the 200V class.

Model			Output [kW]	Reduction Ratio	Inertia Moment $J[\times 10^{-4} \text{ kg} \cdot \text{m}^2]$	Mass [kg]	Brake static friction torque [N · m]
HC-SF52BG1	HC-SFS52BG1	HC-SFS524BG1					
HC-SF52BG1	HC-SFS52BG1	HC-SFS524BG1	0.5	1/11	8.65	20.5	8.3
HC-SF52BG1	HC-SFS52BG1	HC-SFS524BG1	0.5	1/17	8.55	20.5	8.3
HC-SF52BG1	HC-SFS52BG1	HC-SFS524BG1	0.5	1/29	8.48	20.5	8.3

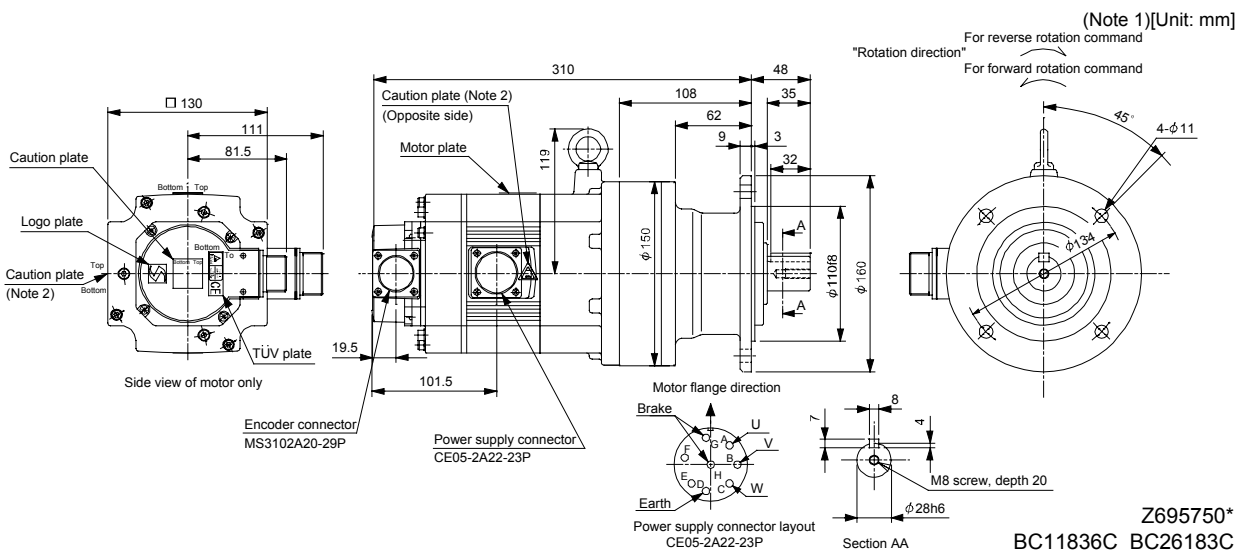

Note 1. The dimensions without tolerances are reference dimensions.
 2. This caution plate is attached to the 400V class motors only, not to the 200V class.

7. OUTLINE DIMENSION DRAWINGS

Model	Output [kW]	Reduction Ratio	Inertia Moment $J[\times 10^{-4} \text{ kg} \cdot \text{m}^2]$	Variable Dimensions	Mass [kg]	Brake static friction torque [N · m]
				L		
HC-SF102BG1 HC-SFS102BG1 HC-SFS1024BG1	1.0	1/59	21.2	432	85	8.3
HC-SF152BG1 HC-SFS152BG1 HC-SFS1524BG1	1.5	1/43	27.5	457	87	8.3
HC-SF152BG1 HC-SFS152BG1 HC-SFS1524BG1	1.5	1/59	27.4	457	87	8.3

(Note)[Unit: mm]

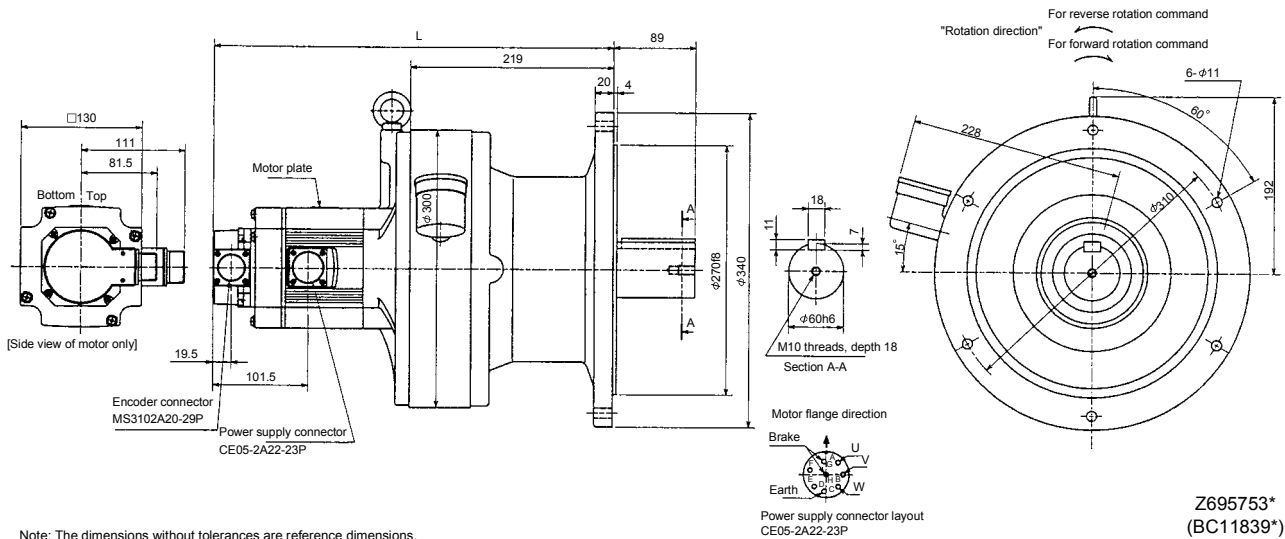

Z695753*
(BC11839*)

Model	Output [kW]	Reduction Ratio	Inertia Moment $J[\times 10^{-4} \text{ kg} \cdot \text{m}^2]$	Variable Dimensions	Mass [kg]	Brake static friction torque [N · m]
				L		
HC-SF102BG1 HC-SFS102BG1 HC-SFS1024BG1	1.0	1/43	17.4	373	50	8.3
HC-SF152BG1 HC-SFS152BG1 HC-SFS1524BG1	1.5	1/29	23.8	398	52	8.3
HC-SF152BG1 HC-SFS152BG1 HC-SFS1524BG1	1.5	1/35	23.7	398	52	8.3

(Note)[Unit: mm]

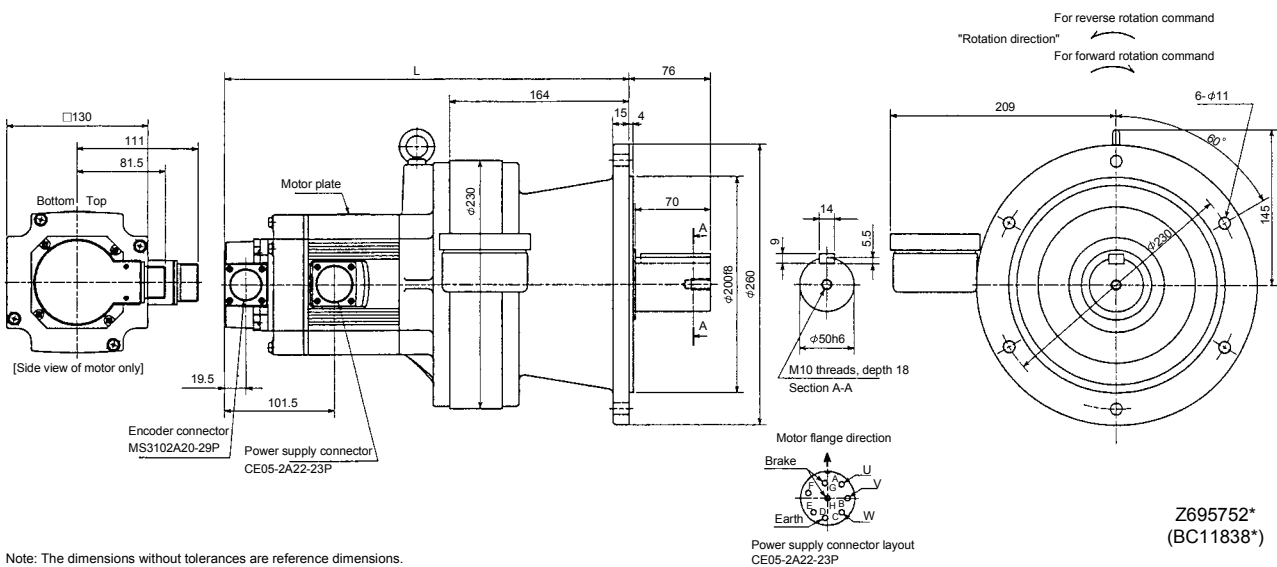

Z695752*
(BC11838*)

7. OUTLINE DIMENSION DRAWINGS

Model	Output [kW]	Reduction Ratio	Inertia Moment $J[\times 10^{-4} \text{ kg} \cdot \text{m}^2]$	Mass [kg]	Brake static friction torque [N · m]
HC-SF202BG1 HC-SFS202BG1 HC-SFS2024BG1	2.0	1/6	55.6	40	43.1
HC-SF202BG1 HC-SFS202BG1 HC-SFS2024BG1	2.0	1/11	54.1	40	43.1
HC-SF202BG1 HC-SFS202BG1 HC-SFS2024BG1	2.0	1/17	53.7	40	43.1

(Note 1)[Unit: mm]

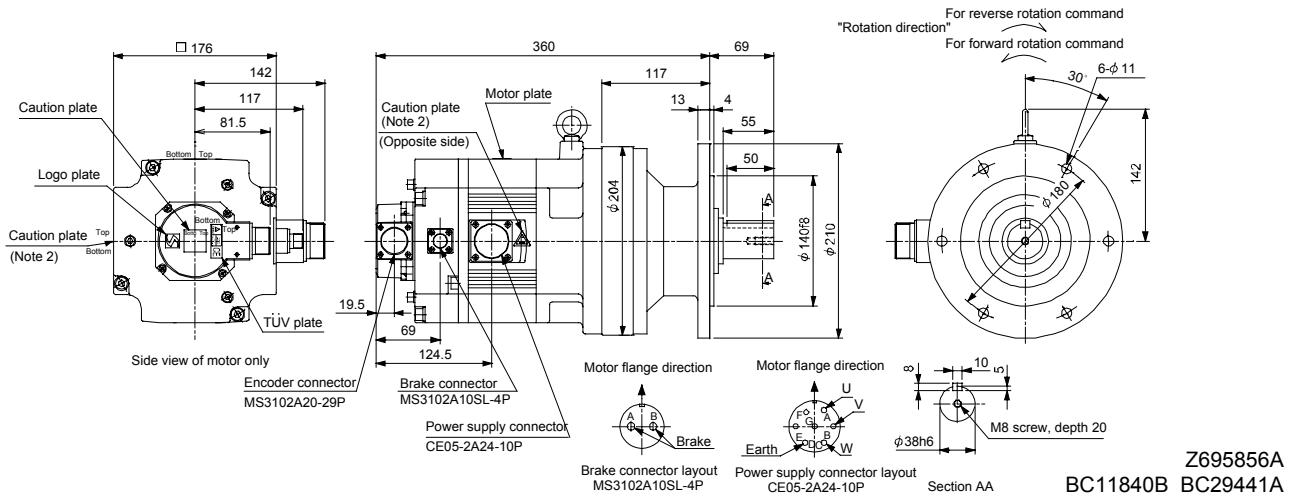

Z695856A
BC11840B BC29441A

Note 1. The dimensions without tolerances are reference dimensions.
2. This caution plate is attached to the 400V class motors only, not to the 200V class.

Model	Output [kW]	Reduction Ratio	Inertia Moment $J[\times 10^{-4} \text{ kg} \cdot \text{m}^2]$	Mass [kg]	Brake static friction torque [N · m]
HC-SF352BG1 HC-SFS352BG1 HC-SFS3524BG1	3.5	1/6	100.1	63	43.1
HC-SF352BG1 HC-SFS352BG1 HC-SFS3524BG1	3.5	1/11	96.2	63	43.1
HC-SF352BG1 HC-SFS352BG1 HC-SFS3524BG1	3.5	1/17	95.0	63	43.1

(Note)[Unit: mm]

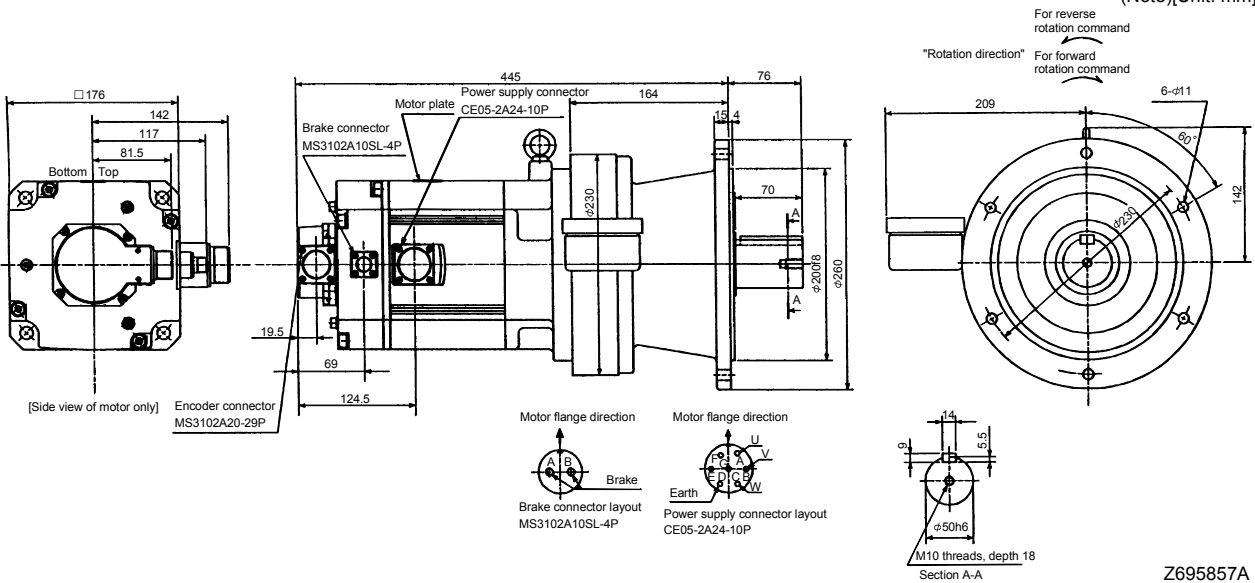

Z695857A
(BC11842*)

Note: The dimensions without tolerances are reference dimensions.

7. OUTLINE DIMENSION DRAWINGS

Model		Output [kW]	Reduction Ratio	Inertia Moment J [$\times 10^{-4}$ kg · m ²]	Variable Dimensions	Mass [kg]	Brake static friction torque [N · m]
					L		
HC-SF202BG1	HC-SFS202BG1 HC-SFS2024BG1	2.0	1/29	58.9	457	90	43.1
HC-SF202BG1	HC-SFS202BG1 HC-SFS2024BG1	2.0	1/35	58.6	457	90	43.1
HC-SF202BG1	HC-SFS202BG1 HC-SFS2024BG1	2.0	1/43	58.4	457	90	43.1
HC-SF202BG1	HC-SFS202BG1 HC-SFS2024BG1	2.0	1/59	58.3	457	90	43.1
HC-SF352BG1	HC-SFS352BG1 HC-SFS3524BG1	3.5	1/29	98.4	499	97	43.1
HC-SF352BG1	HC-SFS352BG1 HC-SFS3524BG1	3.5	1/35	98.1	499	97	43.1

(Note)[Unit: mm]

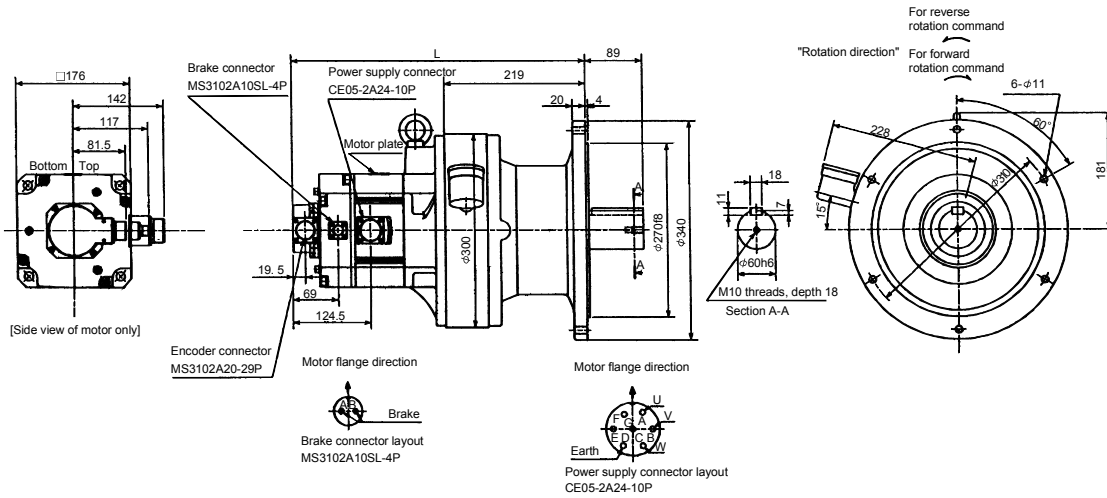

Note: The dimensions without tolerances are reference dimensions.

Z695858A
(BC11841*)

Model		Output [kW]	Reduction Ratio	Inertia Moment J [$\times 10^{-4}$ kg · m ²]	Mass [kg]	Brake static friction torque [N · m]
HC-SF352BG1	HC-SFS352BG1 HC-SFS3524BG1					
HC-SF352BG1	HC-SFS352BG1 HC-SFS3524BG1	3.5	1/59	115.9	139	43.1

(Note)[Unit: mm]

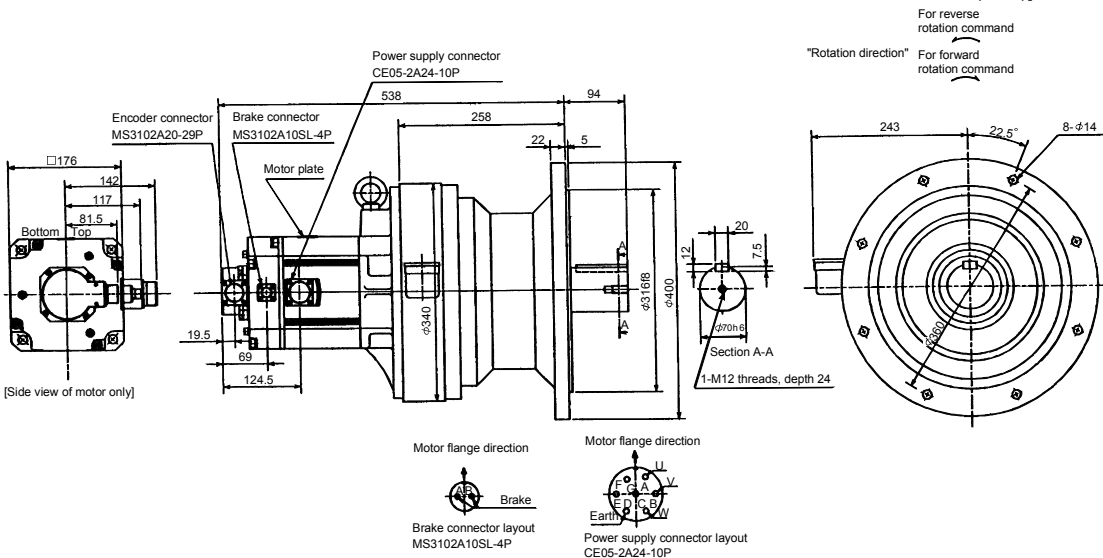

Note: The dimensions without tolerances are reference dimensions.

Z695859A
(BC11843*)

7. OUTLINE DIMENSION DRAWINGS

Model	Output [kW]	Reduction Ratio	Inertia Moment $J[\times 10^{-4} \text{ kg} \cdot \text{m}^2]$	Mass [kg]	Brake static friction torque [N · m]
HC-SF502BG1 HC-SFS502BG1 HC-SFS5024BG1	5.0	1/11	123.4	101	43.1
HC-SF502BG1 HC-SFS502BG1 HC-SFS5024BG1	5.0	1/17	119.4	101	43.1

(Note)[Unit: mm]

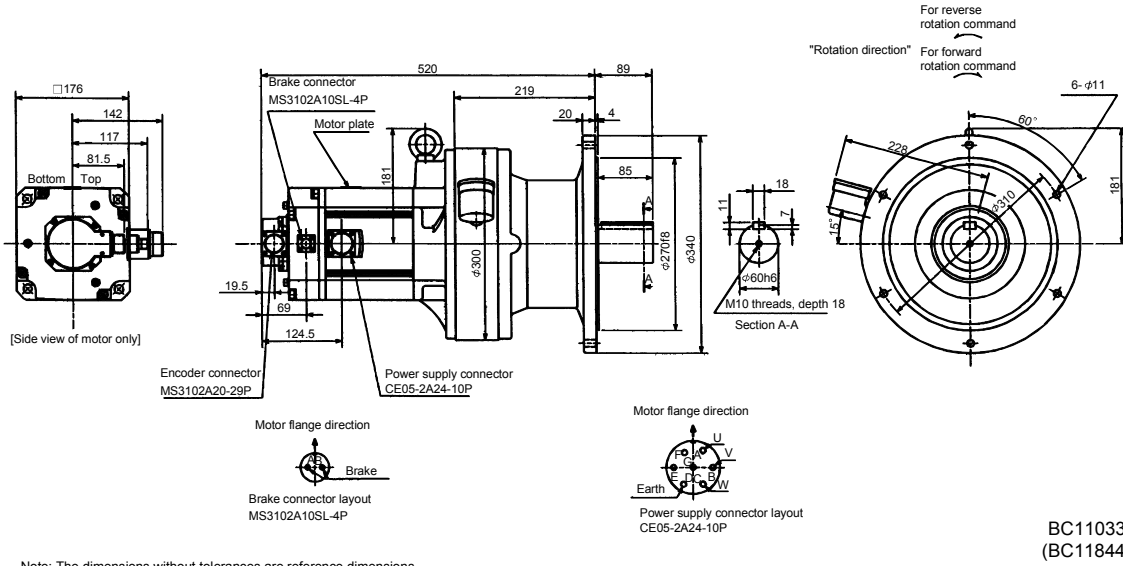

Note: The dimensions without tolerances are reference dimensions.

Model	Output [kW]	Reduction Ratio	Inertia Moment $J[\times 10^{-4} \text{ kg} \cdot \text{m}^2]$	Mass [kg]	Brake static friction torque [N · m]
HC-SF502BG1 HC-SFS502BG1 HC-SFS5024BG1	5.0	1/29	148.5	168	43.1
HC-SF502BG1 HC-SFS502BG1 HC-SFS5024BG1	5.0	1/35	148.0	168	43.1
HC-SF502BG1 HC-SFS502BG1 HC-SFS5024BG1	5.0	1/43	147.0	168	43.1

(Note)[Unit: mm]

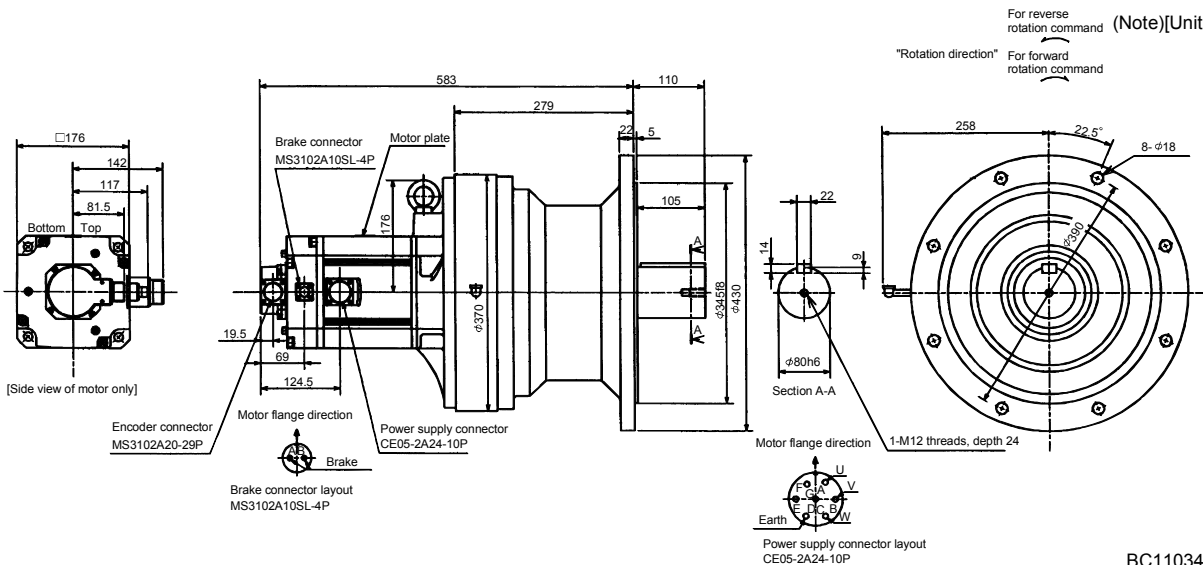

Note: The dimensions without tolerances are reference dimensions.

7. OUTLINE DIMENSION DRAWINGS

Model	Output [kW]	Reduction Ratio	Inertia Moment $J[\times 10^{-4} \text{ kg} \cdot \text{m}^2]$	Mass [kg]	Brake static friction torque [N · m]
HC-SF702BG1 HC-SFS702BG1 HC-SFS7024BG1	7.0	1/11	208.8	152	43.1
HC-SF702BG1 HC-SFS702BG1 HC-SFS7024BG1	7.0	1/17	200.0	152	43.1

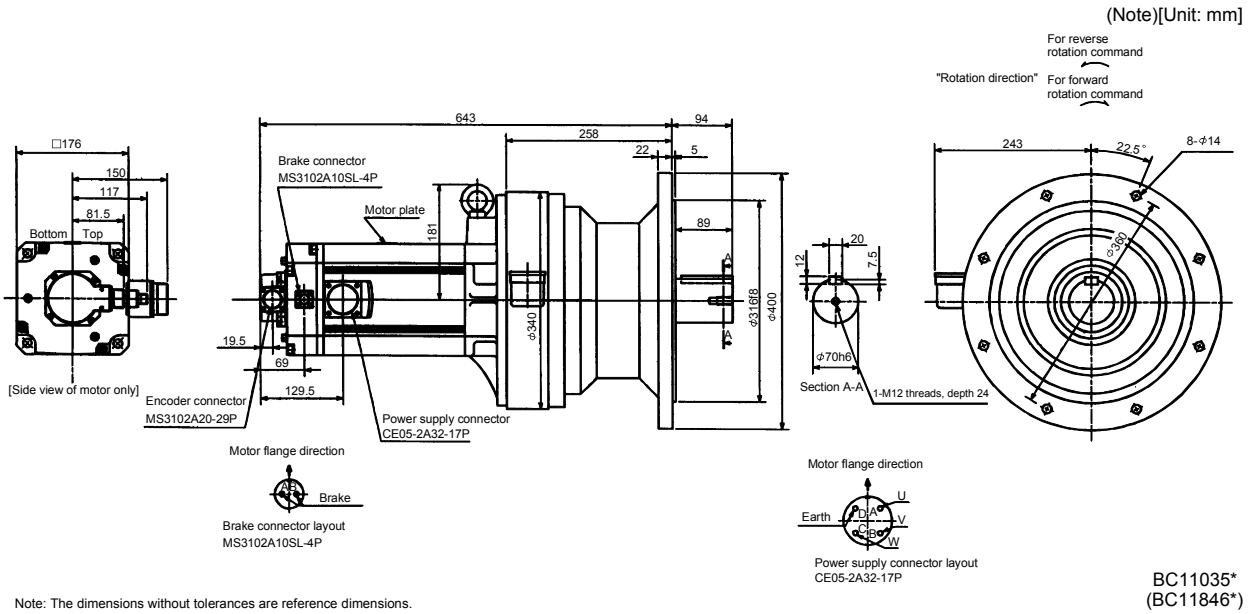

Note: The dimensions without tolerances are reference dimensions.

Model	Output [kW]	Reduction Ratio	Inertia Moment $J[\times 10^{-4} \text{ kg} \cdot \text{m}^2]$	Mass [kg]	Brake static friction torque [N · m]
HC-SF702BG1 HC-SFS702BG1 HC-SFS7024BG1	7.0	1/29	207.5	177	43.1
HC-SF702BG1 HC-SFS702BG1 HC-SFS7024BG1	7.0	1/35	207.0	177	43.1

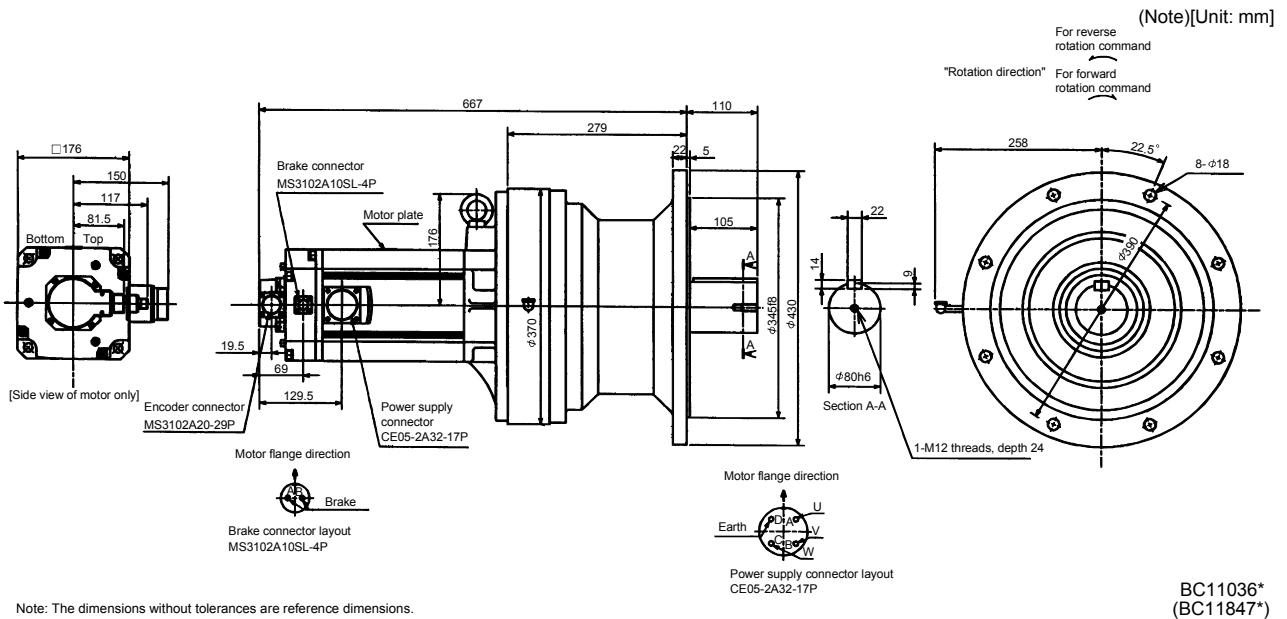

Note: The dimensions without tolerances are reference dimensions.

7. OUTLINE DIMENSION DRAWINGS

Model	Output [kW]	Reduction Ratio	Inertia Moment $J[\times 10^{-4} \text{kg} \cdot \text{m}^2]$	Mass [kg]	Brake static friction torque [N · m]
HC-SF702BG1 HC-SFS702BG1 HC-SFS7024BG1	7.0	1/43	266.8	246	43.1

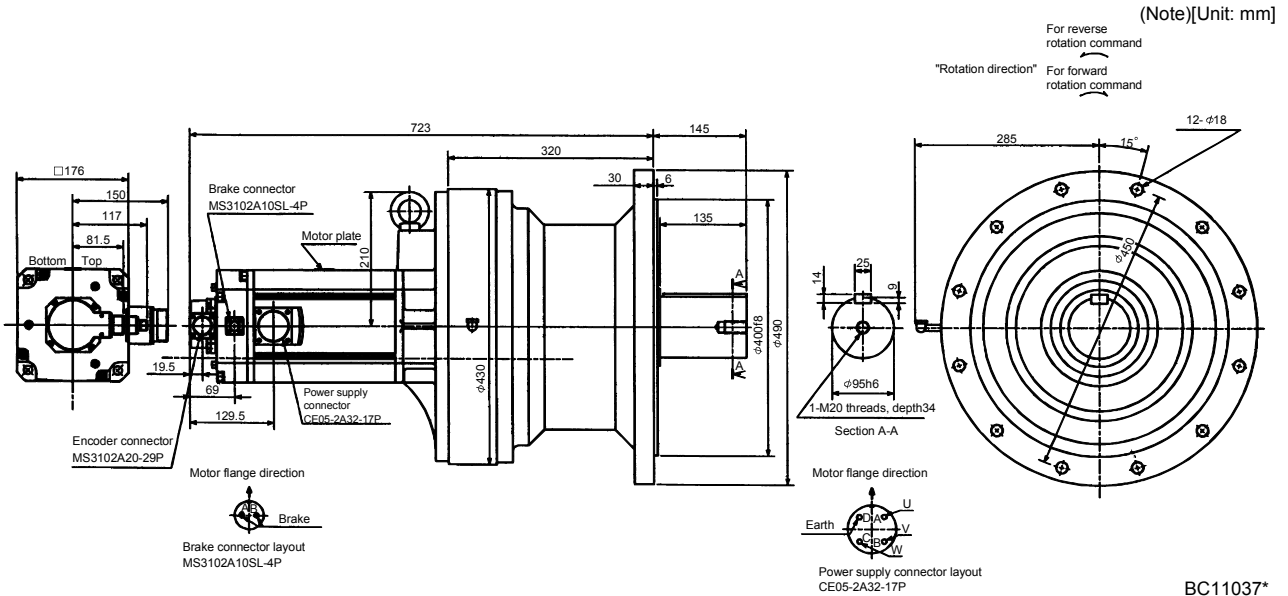

Note: The dimensions without tolerances are reference dimensions.

BC11037*
(BC11848*)

7. OUTLINE DIMENSION DRAWINGS

(5) With reduction gear for precision application

The outer frame of the reduction gear is a material surface such as casting. Its actual dimensions may be 1 to 3mm larger than the drawing dimensions. Design the machine side with allowances.

(a) Without electromagnetic brake

Model			Output [kW]	Reduction Gear Model	Reduction Ratio	Inertia Moment $J[\times 10^{-4} \text{kg} \cdot \text{m}^2]$	Variable Dimensions		Mass [kg]
L	H								
HC-SF52G2	HC-SFS52G2	HC-SFS524G2	0.5	BL2-05B-05MEH	1/5	7.9	276	156	13
HC-SF52G2	HC-SFS52G2	HC-SFS524G2	0.5	BL2-09B-05MEH	1/9	7.55	288	168	13
HC-SF52G2	HC-SFS52G2	HC-SFS524G2	0.5	BL2-20B-05MEH	1/20	8.03	309	189	15
HC-SF102G2	HC-SFS102G2	HC-SFS1024G2	1.0	BL2-05B-10MEH	1/5	15.0	301	156	15
HC-SF102G2	HC-SFS102G2	HC-SFS1024G2	1.0	BL2-09B-10MEH	1/9	14.6	313	168	15
HC-SF152G2	HC-SFS152G2	HC-SFS1524G2	1.5	BL2-05B-15MEH	1/5	21.2	326	156	17

(Note)[Unit: mm]

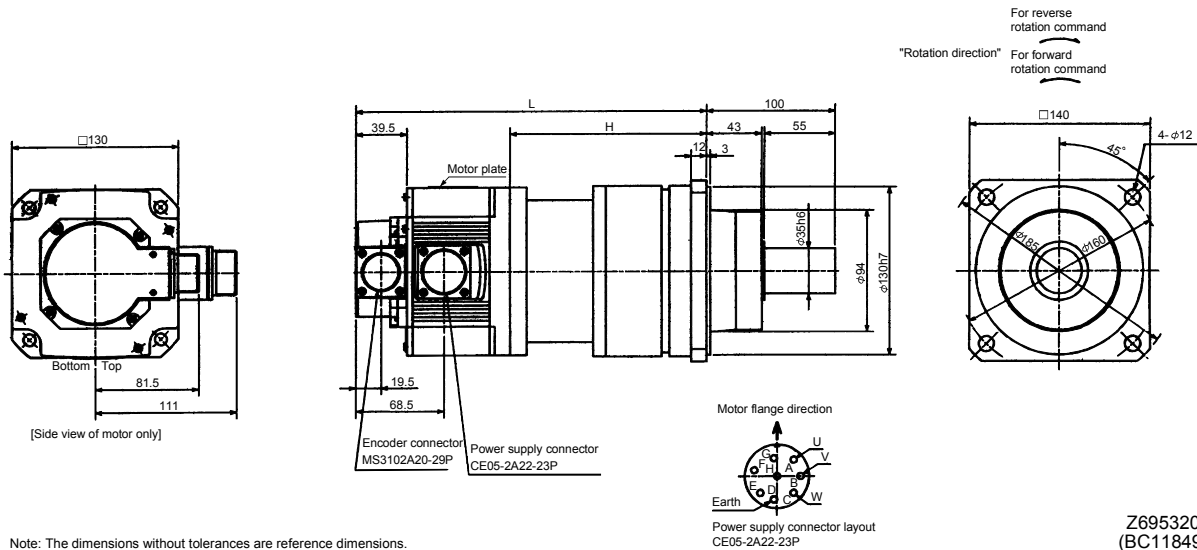

Model			Output [kW]	Reduction Gear Model	Reduction Ratio	Inertia Moment $J[\times 10^{-4} \text{kg} \cdot \text{m}^2]$	Variable Dimensions		Mass [kg]
L	H								
HC-SF52G2	HC-SFS52G2	HC-SFS524G2	0.5	BL3-29B-05MEH	1/29	9.4	337	217	30
HC-SF52G2	HC-SFS52G2	HC-SFS524G2	0.5	BL3-45B-05MEH	1/45	8.43	343	223	30
HC-SF102G2	HC-SFS102G2	HC-SFS1024G2	1.0	BL3-20B-10MEH	1/20	18.4	362	217	32
HC-SF102G2	HC-SFS102G2	HC-SFS1024G2	1.0	BL3-29B-10MEH	1/29	16.5	362	217	32
HC-SF152G2	HC-SFS152G2	HC-SFS1524G2	1.5	BL3-09B-15MEH	1/9	24.7	379	209	34
HC-SF152G2	HC-SFS152G2	HC-SFS1524G2	1.5	BL3-20B-15MEH	1/20	24.6	387	217	34

(Note)[Unit: mm]

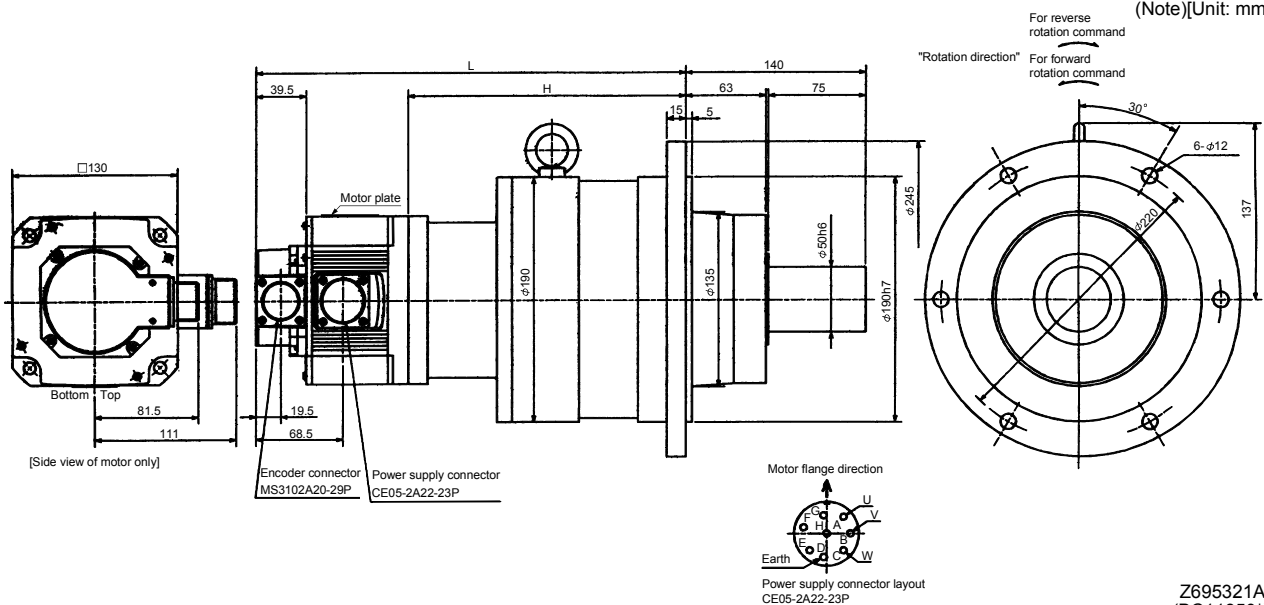

7. OUTLINE DIMENSION DRAWINGS

Model	Output [kW]	Reduction Gear Model	Reduction Ratio	Inertia Moment $J[\times 10^{-4} \text{ kg} \cdot \text{m}^2]$	Variable Dimensions		Mass [kg]
					L	H	
HC-SF102G2 HC-SFS102G2 HC-SFS1024G2	1.0	BL4-45B-10MEH	1/45	20.3	389	244	52
HC-SF152G2 HC-SFS152G2 HC-SFS1524G2	1.5	BL4-29B-15MEH	1/29	30.3	411	241	54
HC-SF152G2 HC-SFS152G2 HC-SFS1524G2	1.5	BL4-45B-15MEH	1/45	26.5	414	244	54

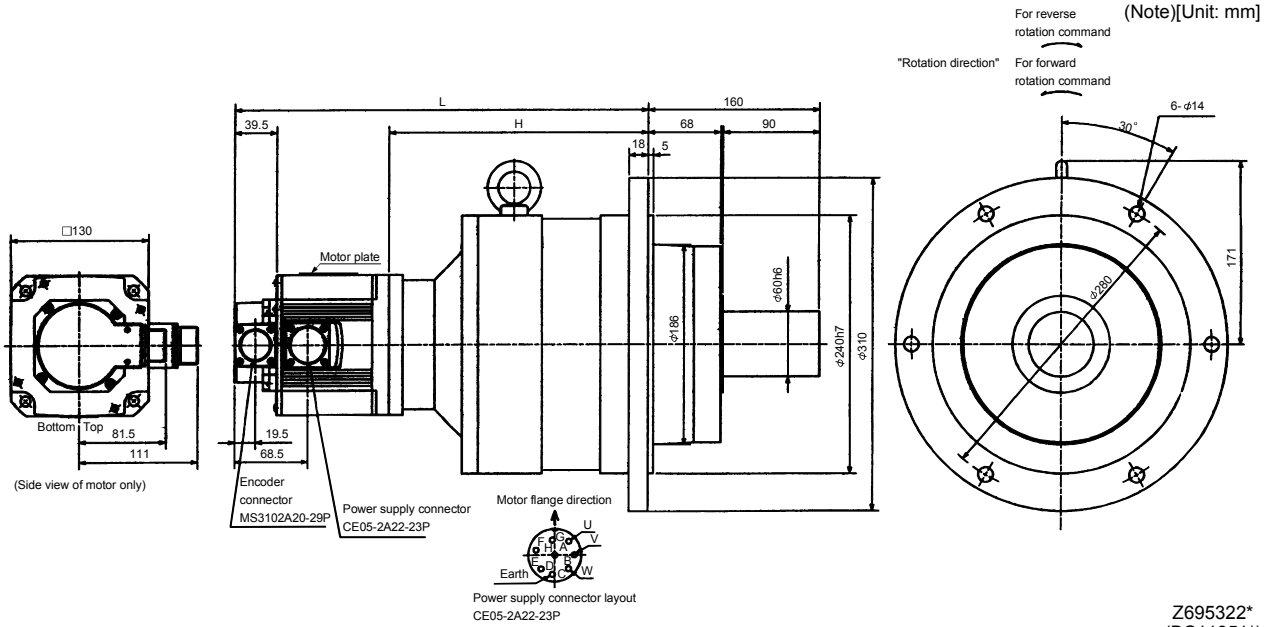

Note: The dimensions without tolerances are reference dimensions.

Model	Output [kW]	Reduction Gear Model	Reduction Ratio	Inertia Moment $J[\times 10^{-4} \text{ kg} \cdot \text{m}^2]$	Variable Dimensions		Mass [kg]
					L	H	
HC-SF202G2 HC-SFS202G2 HC-SFS2024G2	2.0	BL3-05B-20MEH	1/5	49.6	348	203	30
HC-SF202G2 HC-SFS202G2 HC-SFS2024G2	2.0	BL3-09B-20MEH	1/9	47.2	375	230	37

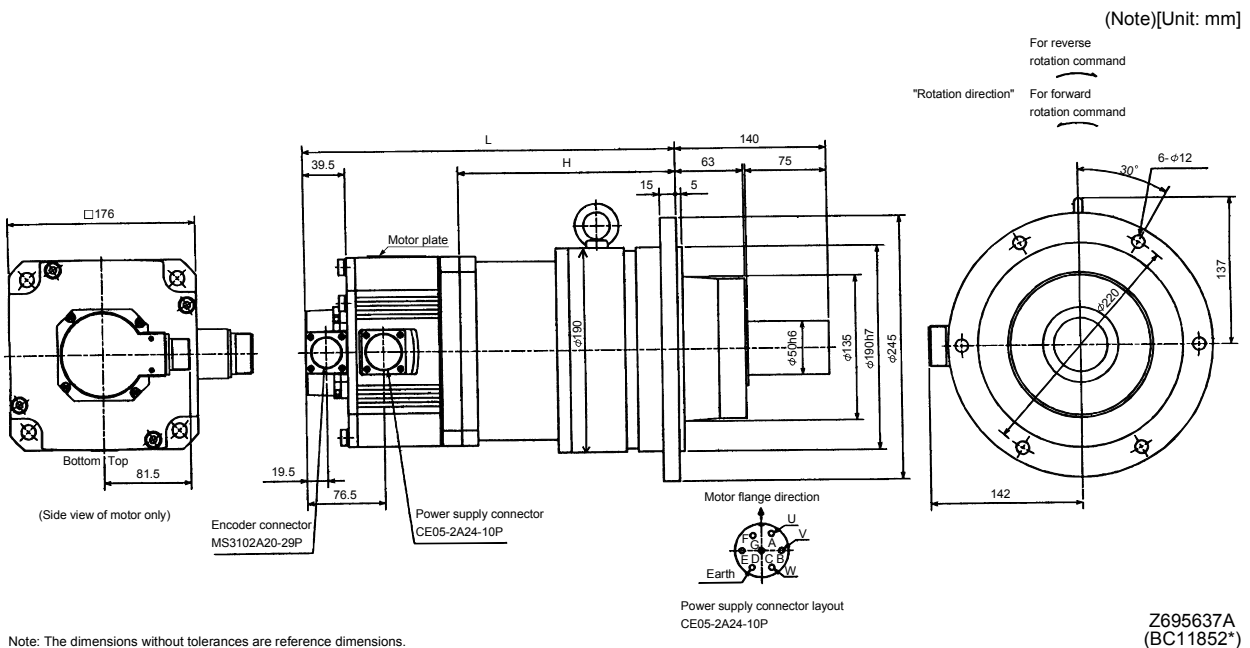

Note: The dimensions without tolerances are reference dimensions.

7. OUTLINE DIMENSION DRAWINGS

Model			Output [kW]	Reduction Gear Model	Reduction Ratio	Variable Dimensions		Inertia Moment J[$\times 10^{-4}$ kg \cdot m 2]	Mass [kg]
L	H								
HC-SF202G2	HC-SFS202G2	HC-SFS2024G2	2.0	BL4-20B-20MEH	1/20	407	262	59.6	57
HC-SF202G2	HC-SFS202G2	HC-SFS2024G2	2.0	BL4-29B-20MEH	1/29	407	262	52.8	57
HC-SF202G2	HC-SFS202G2	HC-SFS2024G2	2.0	BL4-45B-20MEH	1/45	410	265	49.1	57
HC-SF352G2	HC-SFS352G2	HC-SFS3524G2	3.5	BL4-05B-35MEH	1/5	410	223	99.4	54
HC-SF352G2	HC-SFS352G2	HC-SFS3524G2	3.5	BL4-09B-35MEH	1/9	442	255	91.5	64
HC-SF352G2	HC-SFS352G2	HC-SFS3524G2	3.5	BL4-20B-35MEH	1/20	449	262	99.1	64

(Note)[Unit: mm]

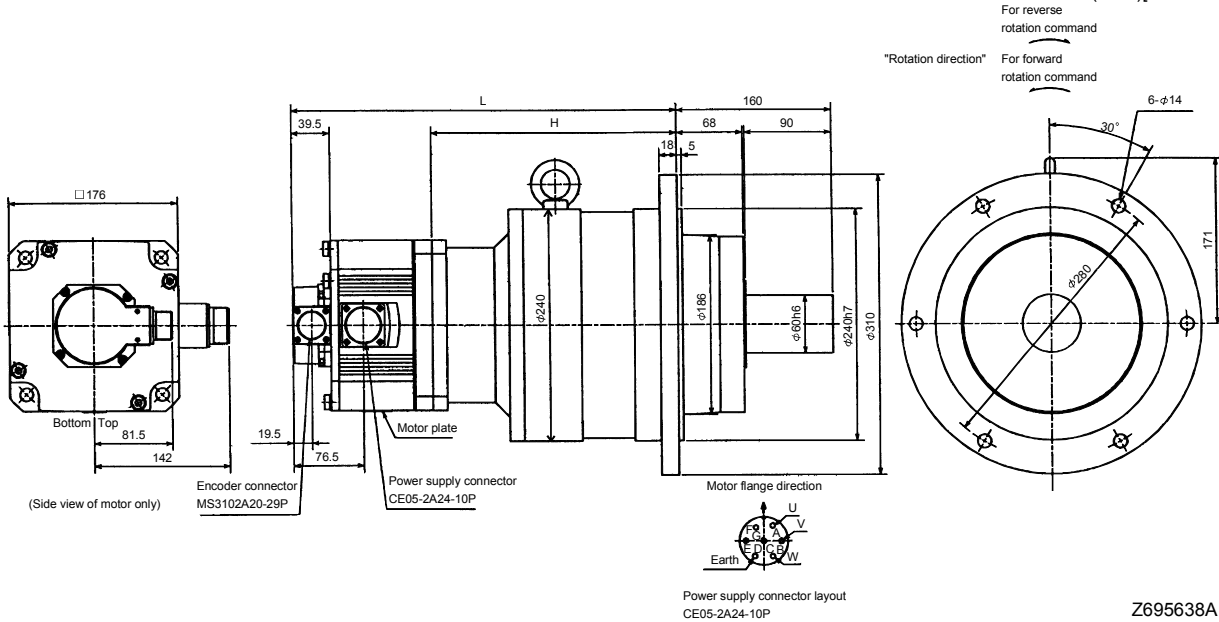

Note: The dimensions without tolerances are reference dimensions.

Power supply connector layout
CE05-2A24-10P

Z695638A
(BC11853*)

Model		Output [kW]	Reduction Gear Model	Reduction Ratio	Variable Dimensions		Inertia Moment J[$\times 10^{-4}$ kg \cdot m 2]	Mass [kg]
L	H							
HC-SF502G2	HC-SFS502G2 HC-SFS5024G2	5.0	BL4-05B-50MEH	1/5	431	223	118.4	58
HC-SF502G2	HC-SFS502G2 HC-SFS5024G2	5.0	BL4-09B-50MEH	1/9	463	255	110.5	68

(Note)[Unit: mm]

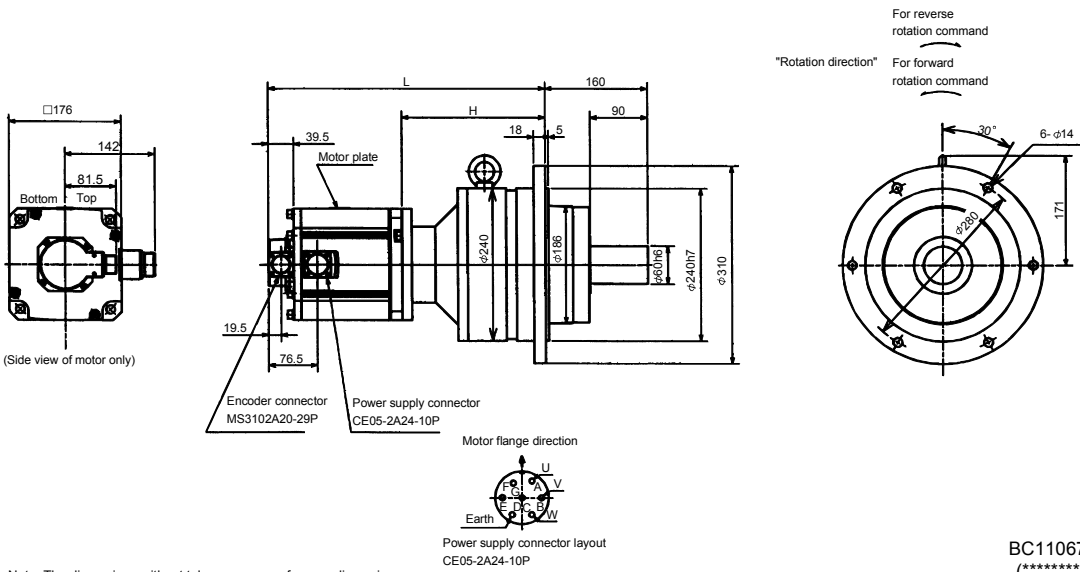

Note: The dimensions without tolerances are reference dimensions.

Power supply connector layout
CE05-2A24-10P

BC11067*
(*****)

7. OUTLINE DIMENSION DRAWINGS

Model	Output [kW]	Reduction Gear Model	Reduction Ratio	Inertia Moment $J[\times 10^{-4} \text{kg} \cdot \text{m}^2]$	Mass [kg]
HC-SF702G2 HC-SFS702G2 HC-SFS7024G2	7.0	BL4-05B-70MEH	1/5	177.4	67

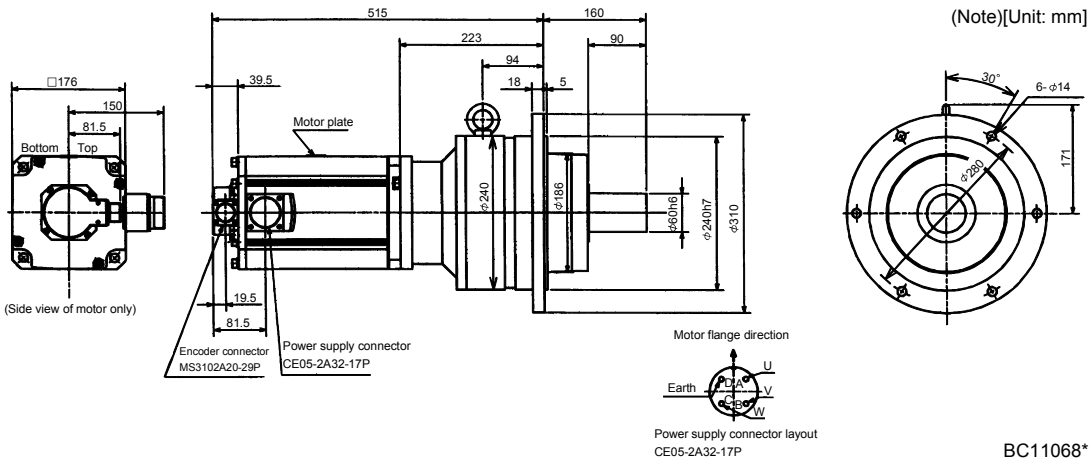

Note: The dimensions without tolerances are reference dimensions.

(b) With electromagnetic brake

Model	Output [kW]	Reduction Gear Model	Reduction Ratio	Inertia Moment $J[\times 10^{-4} \text{kg} \cdot \text{m}^2]$	Variable Dimensions		Brake static friction torque [N · m]	Mass [kg]
					L	H		
HC-SF52BG2 HC-SFS52BG2 HC-SFS524BG2	0.5	BL2-05B-05MEH	1/5	9.6	309	156	8.5	15
HC-SF52BG2 HC-SFS52BG2 HC-SFS524BG2	0.5	BL2-09B-05MEH	1/9	9.25	321	168	8.5	15
HC-SF52BG2 HC-SFS52BG2 HC-SFS524BG2	0.5	BL2-20B-05MEH	1/20	9.73	342	189	8.5	17
HC-SF102BG2 HC-SFS102BG2 HC-SFS1024BG2	1.0	BL2-05B-10MEH	1/5	16.7	334	156	8.5	17
HC-SF102BG2 HC-SFS102BG2 HC-SFS1024BG2	1.0	BL2-09B-10MEH	1/9	16.3	346	168	8.5	17
HC-SF152BG2 HC-SFS152BG2 HC-SFS1524BG2	1.5	BL2-05B-15MEH	1/5	22.9	359	156	8.5	19

(Note)[Unit: mm]

For reverse rotation command
"Rotation direction" For forward rotation command

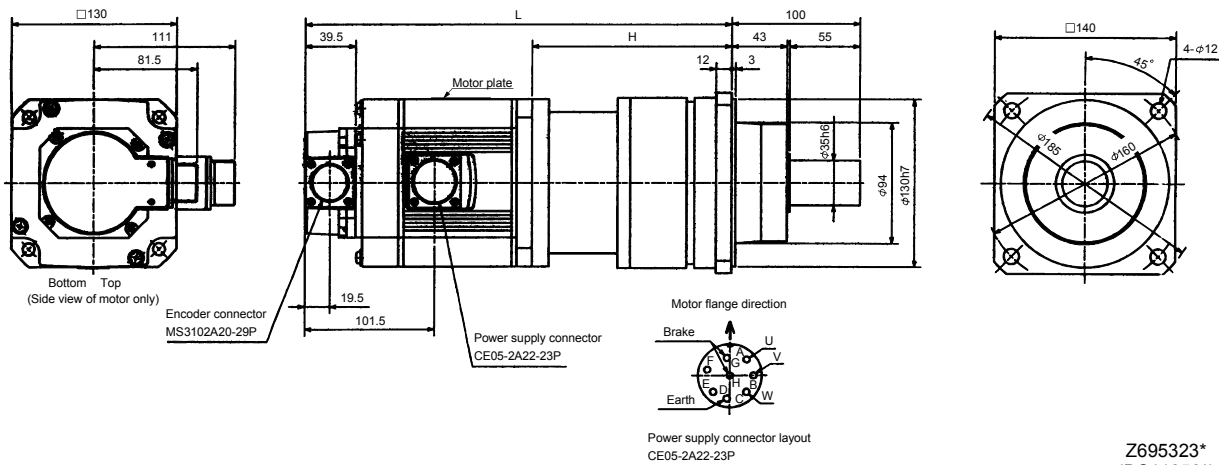

Note: The dimensions without tolerances are reference dimensions.

7. OUTLINE DIMENSION DRAWINGS

Model			Output [kW]	Reduction Gear Model	Reduction Ratio	Inertia Moment $J[\times 10^{-4} \text{ kg} \cdot \text{m}^2]$	Variable Dimensions		Brake static friction torque [N · m]	Mass [kg]
							L	H		
HC-SF52BG2	HC-SFS52BG2	HC-SFS524BG2	0.5	BL3-29B-05MEH	1/29	11.1	370	217	8.5	32
HC-SF52BG2	HC-SFS52BG2	HC-SFS524BG2	0.5	BL3-45B-05MEH	1/45	10.1	376	223	8.5	32
HC-SF102BG2	HC-SFS102BG2	HC-SFS1024BG2	1.0	BL3-20B-10MEH	1/20	20.1	395	217	8.5	34
HC-SF102BG2	HC-SFS102BG2	HC-SFS1024BG2	1.0	BL3-29B-10MEH	1/29	18.2	395	217	8.5	34
HC-SF152BG2	HC-SFS152BG2	HC-SFS1524BG2	1.5	BL3-09B-15MEH	1/9	26.4	412	209	8.5	36
HC-SF152BG2	HC-SFS152BG2	HC-SFS1524BG2	1.5	BL3-20B-15MEH	1/20	26.3	420	217	8.5	36

(Note)[Unit: mm]

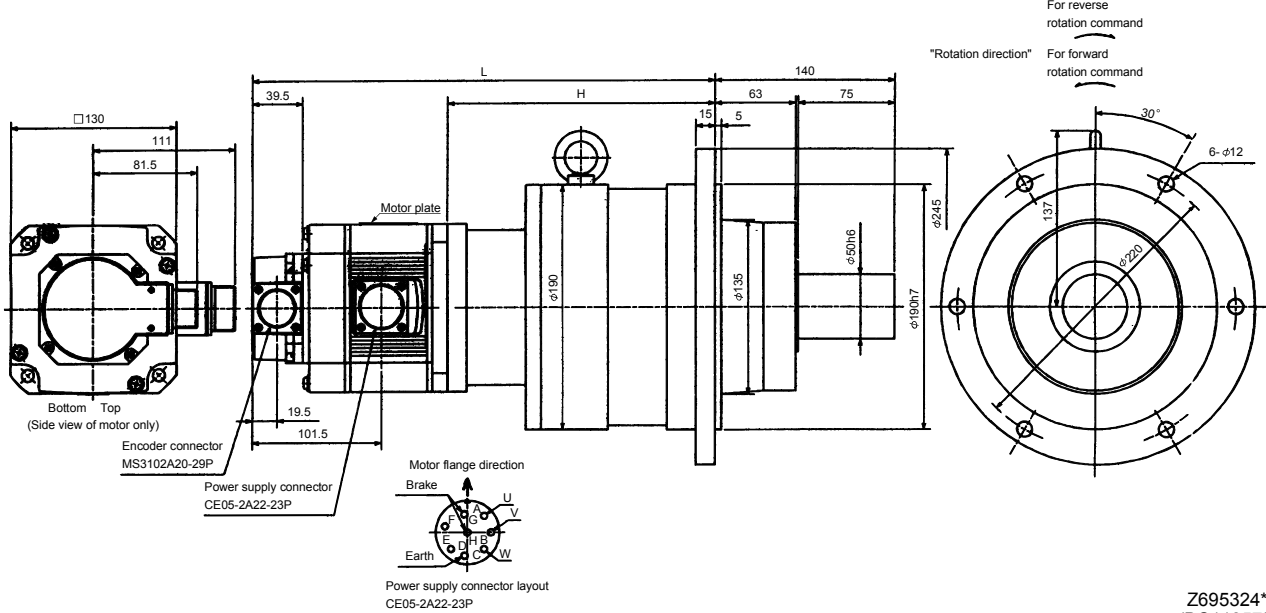

Note: The dimensions without tolerances are reference dimensions.

Model			Output [kW]	Reduction Gear Model	Reduction Ratio	Inertia Moment $J[\times 10^{-4} \text{ kg} \cdot \text{m}^2]$	Variable Dimensions		Brake static friction torque [N · m]	Mass [kg]
							L	H		
HC-SF102BG2	HC-SFS102BG2	HC-SFS1024BG2	1.0	BL4-45B-10MEH	1/45	22.0	422	244	8.5	54
HC-SF152BG2	HC-SFS152BG2	HC-SFS1524BG2	1.5	BL4-29B-15MEH	1/29	32.0	444	241	8.5	56
HC-SF152BG2	HC-SFS152BG2	HC-SFS1524BG2	1.5	BL4-45B-15MEH	1/45	28.2	447	244	8.5	56

(Note)[Unit: mm]

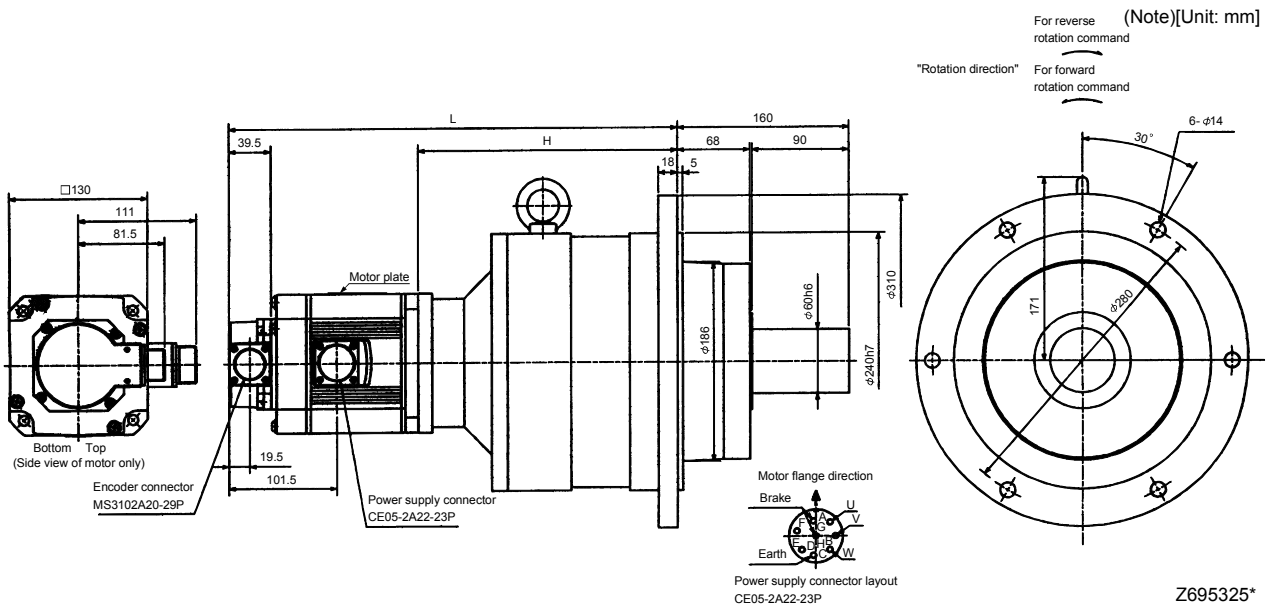

Note: The dimensions without tolerances are reference dimensions.

7. OUTLINE DIMENSION DRAWINGS

Model			Output [kW]	Reduction Gear Model	Reduction Ratio	Variable Dimensions		Brake static friction torque [N · m]	Inertia Moment J [$\times 10^{-4}$ kg · m ²]	Mass [kg]
						L	H			
HC-SF202BG2	HC-SFS202BG2	HC-SFS2024BG2	2.0	BL3-05B-20MEH	1/5	396	203	43.1	59.6	36
HC-SF202BG2	HC-SFS202BG2	HC-SFS2024BG2	2.0	BL3-09B-20MEH	1/9	423	230	43.1	57.2	43

(Note)[Unit: mm]

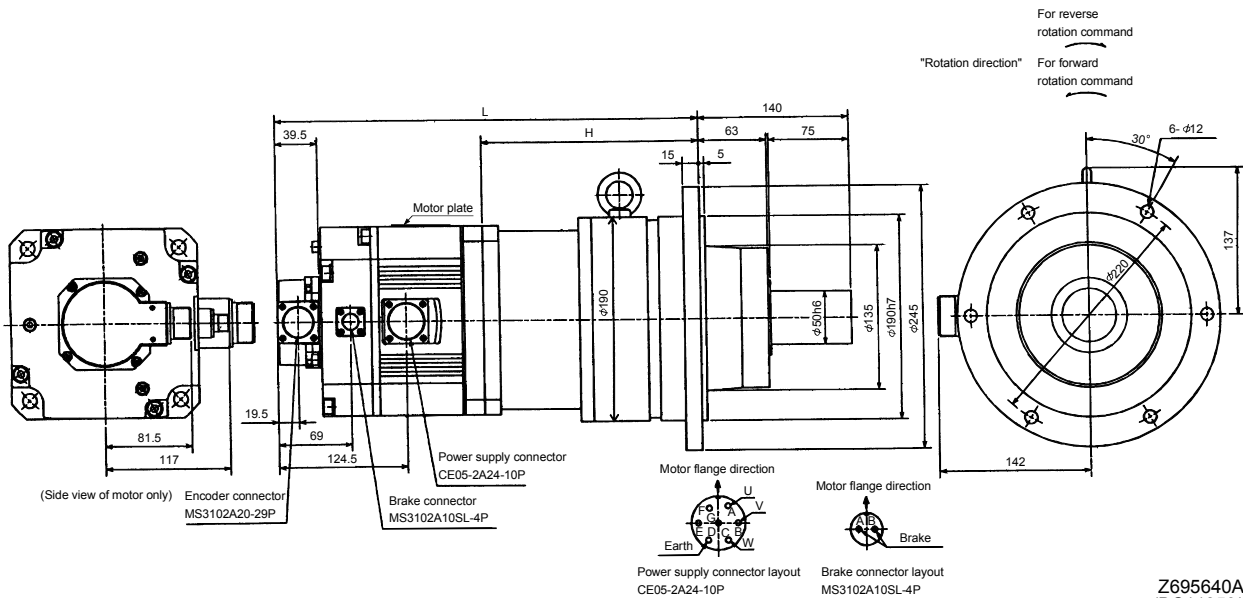

Z695640A
(BC11859*)

Note: The dimensions without tolerances are reference dimensions.

Model			Output [kW]	Reduction Gear Model	Reduction Ratio	Variable Dimensions		Brake static friction torque [N · m]	Inertia Moment J [$\times 10^{-4}$ kg · m ²]	Mass [kg]
						L	H			
HC-SF202BG2	HC-SFS202BG2	HC-SFS2024BG2	2.0	BL4-20B-20MEH	1/20	455	262	43.1	69.6	63
HC-SF202BG2	HC-SFS202BG2	HC-SFS2024BG2	2.0	BL4-29B-20MEH	1/29	455	262	43.1	62.8	63
HC-SF202BG2	HC-SFS202BG2	HC-SFS2024BG2	2.0	BL4-45B-20MEH	1/45	458	265	43.1	59.1	63
HC-SF352BG2	HC-SFS352BG2	HC-SFS3524BG2	3.5	BL4-05B-35MEH	1/5	458	223	43.1	109.4	60
HC-SF352BG2	HC-SFS352BG2	HC-SFS3524BG2	3.5	BL4-09B-35MEH	1/9	490	255	43.1	101.5	70
HC-SF352BG2	HC-SFS352BG2	HC-SFS3524BG2	3.5	BL4-20B-35MEH	1/20	497	262	43.1	109.1	70

(Note)[Unit: mm]

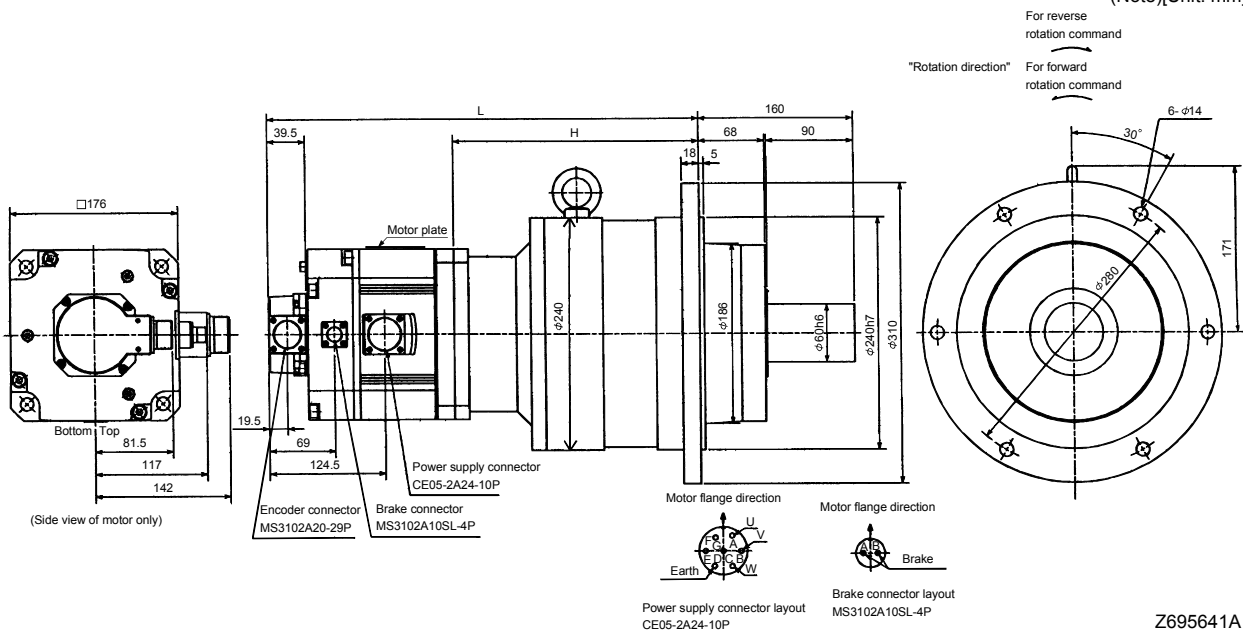

Z695641A
(BC11860*)

Note: The dimensions without tolerances are reference dimensions.

7. OUTLINE DIMENSION DRAWINGS

Model	Output [kW]	Reduction Gear Model	Reduction Ratio	Variable Dimensions		Inertia Moment $J[\times 10^{-4} \text{kg} \cdot \text{m}^2]$	Mass [kg]	Brake static friction torque [N · m]
				L	H			
HC-SF502BG2 HC-SFS502BG2 HC-SFS5024BG2	5.0	BL4-05B-50MEH	1/5	479	223	128.4	64	43.1
HC-SF502BG2 HC-SFS502BG2 HC-SFS5024BG2	5.0	BL4-09B-50MEH	1/9	511	255	120.5	74	43.1

(Note)[Unit: mm]

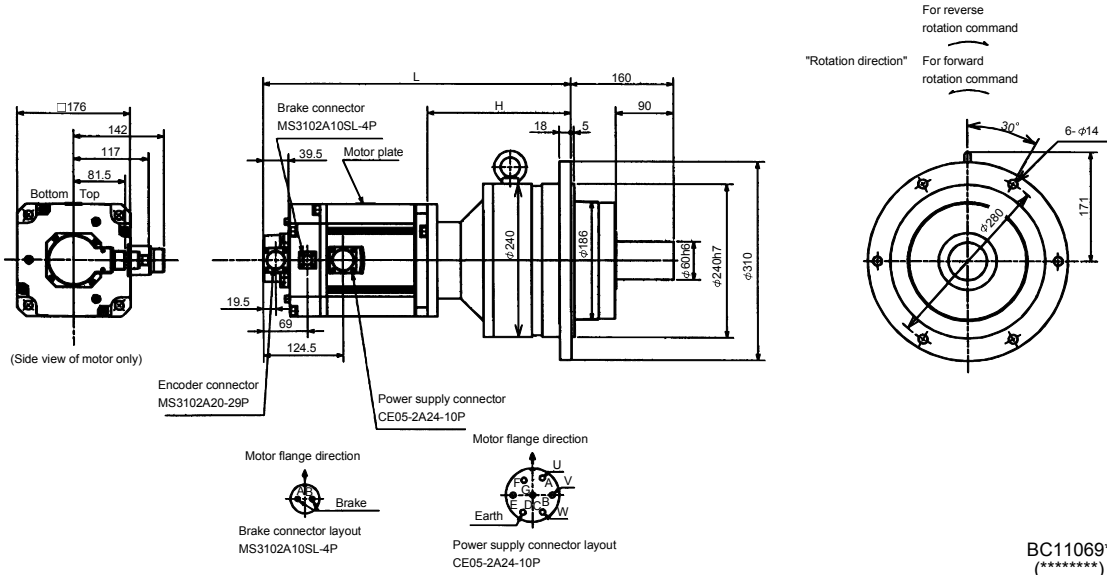

Note: The dimensions without tolerances are reference dimensions.

Model	Output [kW]	Reduction Gear Model	Reduction Ratio	Inertia Moment $J[\times 10^{-4} \text{kg} \cdot \text{m}^2]$	Mass [kg]	Brake static friction torque [N · m]

(Note)[Unit: mm]

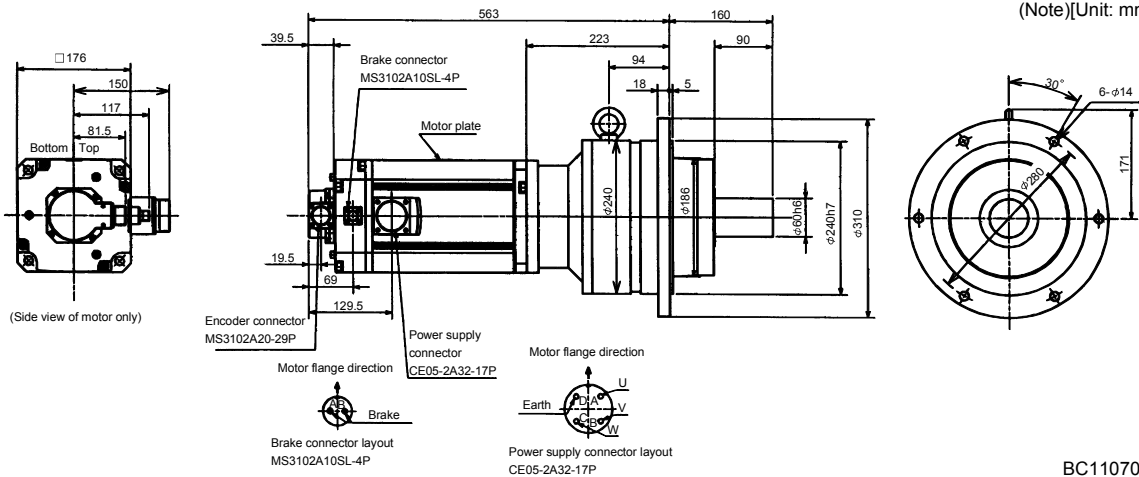

Note: The dimensions without tolerances are reference dimensions.

7. OUTLINE DIMENSION DRAWINGS

7.1.4 HC-RF · HC-RFS series

If the above indicated value is exceeded, please consult us.

(1) Standard (without electromagnetic brake, without reduction gear)

Model		Output [kW]	Inertia Moment $J[\times 10^{-4} \text{kg} \cdot \text{m}^2]$	Variable Dimensions		Mass [kg]
				L	KL	
HC-RF103	HC-RFS103	1.0	1.5	147	71	3.9
HC-RF153	HC-RFS153	1.5	1.9	172	96	5.0
HC-RF203	HC-RFS203	2.0	2.3	197	121	6.2

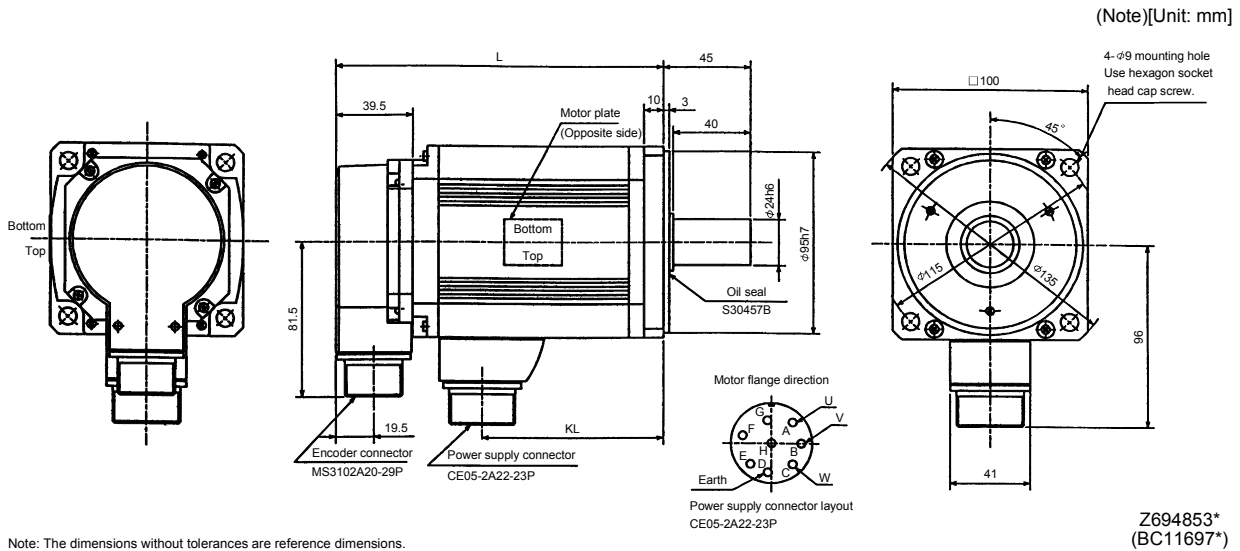

Model		Output [kW]	Inertia Moment $J[\times 10^{-4} \text{kg} \cdot \text{m}^2]$	Variable Dimensions		Mass [kg]
				L	KL	
HC-RF353	HC-RFS353	3.5	8.6	217	148	12
HC-RF503	HC-RFS503	5.0	12.0	274	205	17

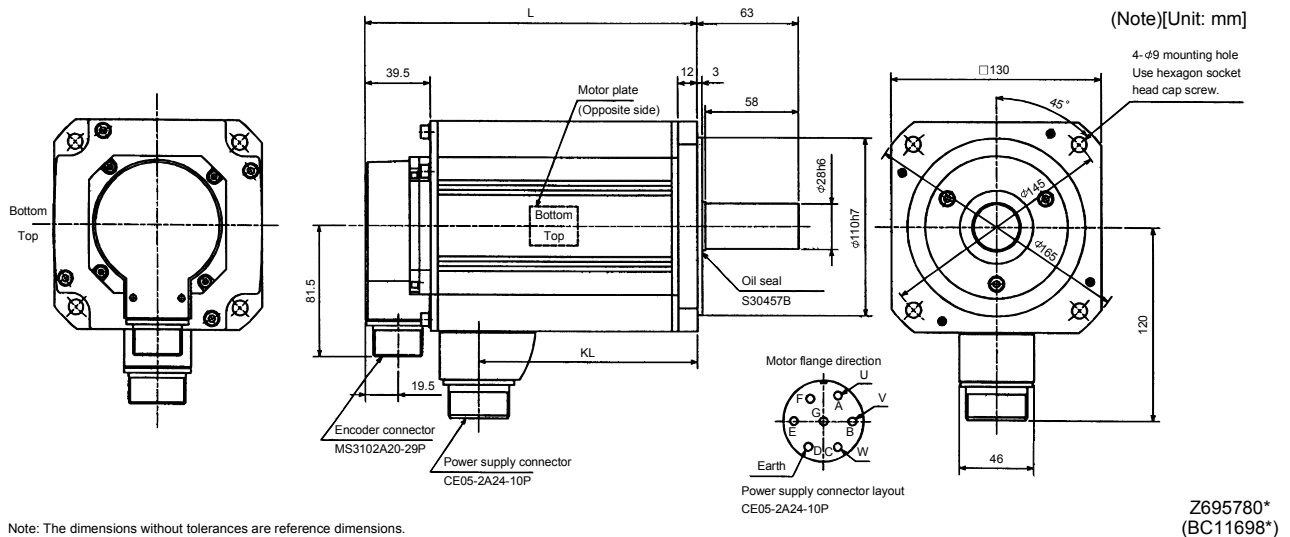

7. OUTLINE DIMENSION DRAWINGS

(2) With electromagnetic brake

Model	Output [kW]	Inertia Moment $J[\times 10^{-4} \text{kg} \cdot \text{m}^2]$	Variable Dimensions		Brake static friction torque [N · m]	Mass [kg]
			L	KL		
HC-RF103B HC-RFS103B	1.0	1.85	185	71	7	6.0
HC-RF153B HC-RFS153B	1.5	2.25	210	96	7	7.0
HC-RF203B HC-RFS203B	2.0	2.65	235	121	7	8.3

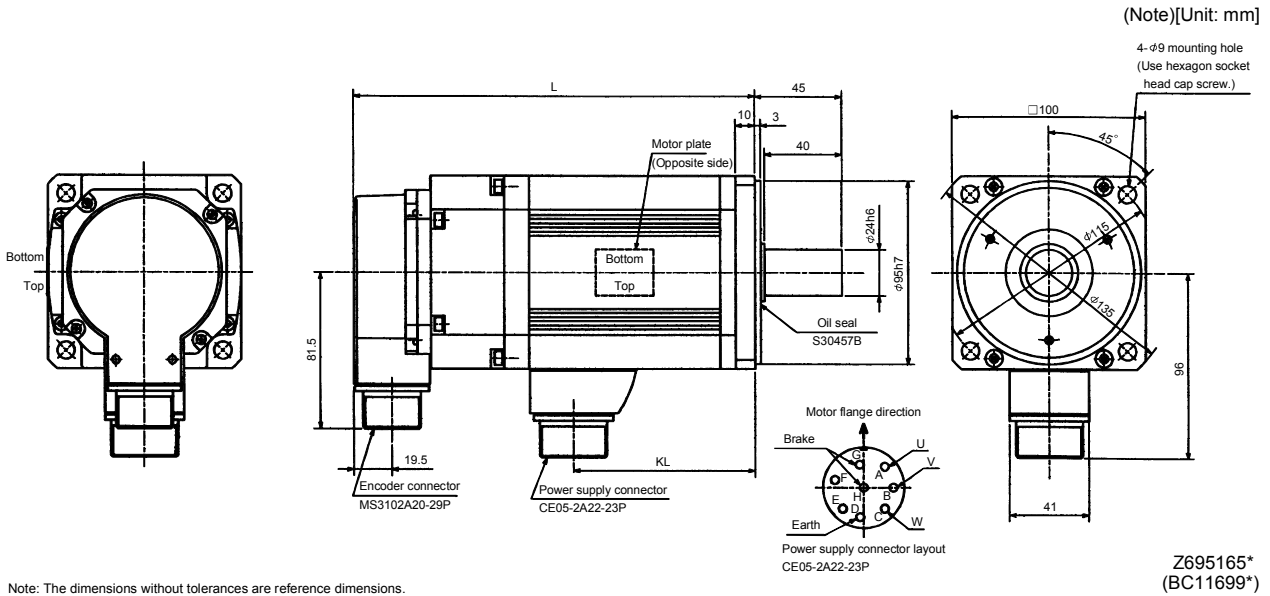

Model	Output [kW]	Inertia Moment $J[\times 10^{-4} \text{kg} \cdot \text{m}^2]$	Variable Dimensions		Brake static friction torque [N · m]	Mass [kg]
			L	KL		
HC-RF353B HC-RFS353B	3.5	11.8	254	148	16.7	15
HC-RF503B HC-RFS503B	5.0	15.5	311	205	16.7	21

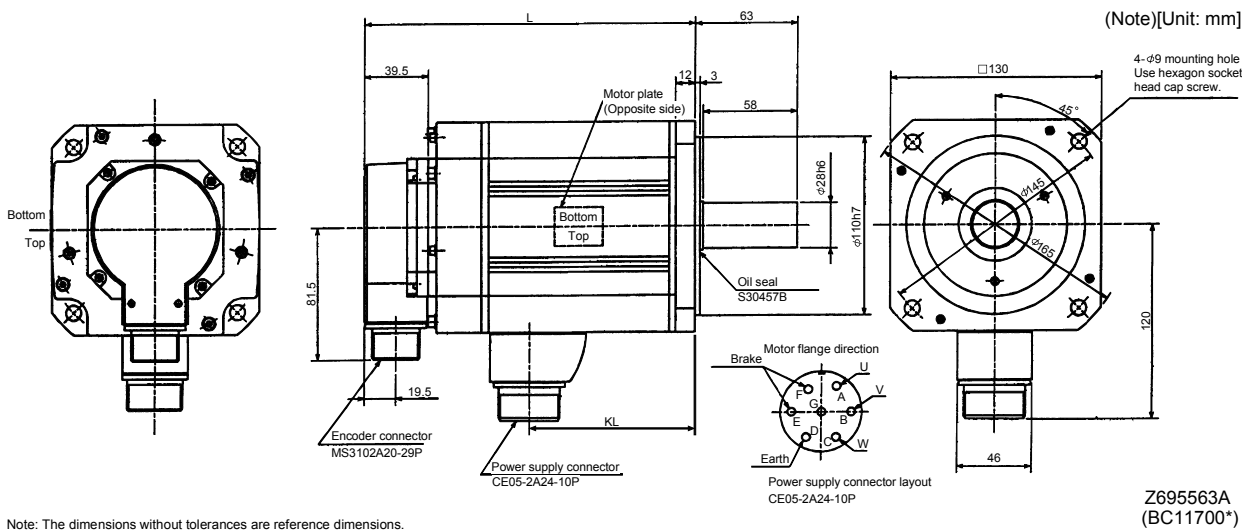

7. OUTLINE DIMENSION DRAWINGS

(3) With reduction gear for precision application

The outer frame of the reduction gear is a material surface such as casting. Its actual dimensions may be 1 to 3mm larger than the drawing dimensions. Design the machine side with allowances.

(a) Without electromagnetic brake

Model	Output [kW]	Reduction Gear Model	Reduction Ratio	Inertia Moment $J[\times 10^{-4} \text{kg} \cdot \text{m}^2]$	Variable Dimensions		Mass [kg]
					L	H	
HC-RF103G2 HC-RFS103G2	1.0	BL2-05B-10MEKD	1/5	4.95	301	154	11.9
HC-RF103G2 HC-RFS103G2	1.0	BL2-09B-10MEKD	1/9	4.6	313	166	11.9
HC-RF153G2 HC-RFS153G2	1.5	BL2-05B-15MEKD	1/5	5.35	326	154	13
HC-RF203G2 HC-RFS203G2	2.0	BL2-05B-20MEKD	1/5	5.75	351	154	14.2

(Note)[Unit: mm]

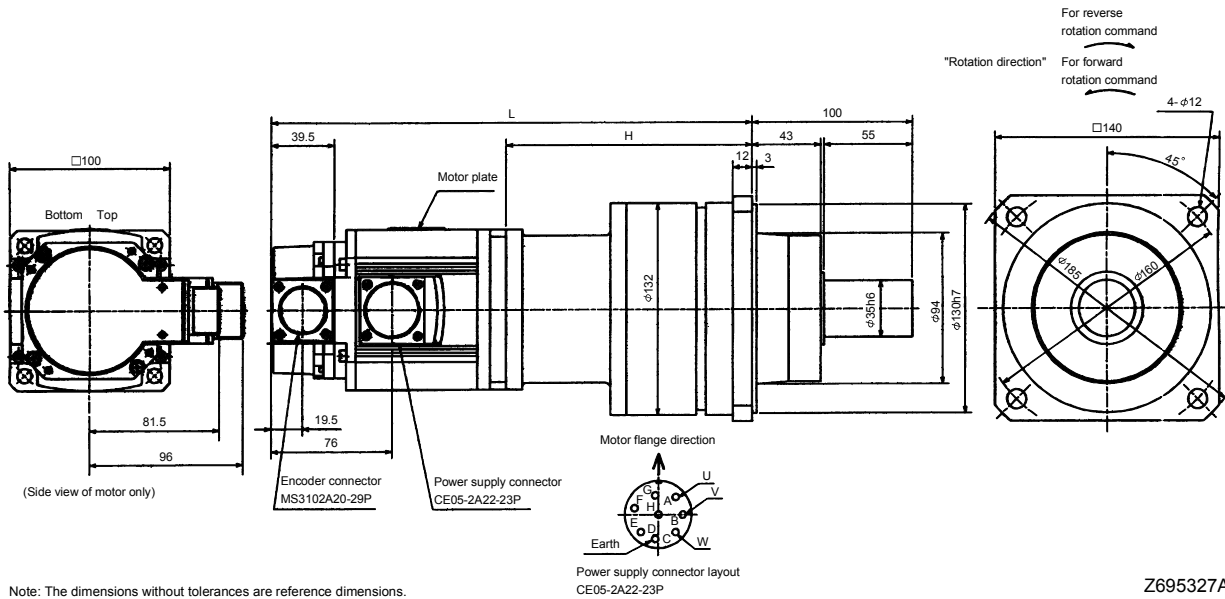

Note: The dimensions without tolerances are reference dimensions.

Z695327A

Model	Output [kW]	Reduction Gear Model	Reduction Ratio	Inertia Moment $J[\times 10^{-4} \text{kg} \cdot \text{m}^2]$	Variable Dimensions			Mass [kg]
					L	H	LI	
HC-RF103G2 HC-RFS103G2	1.0	BL3-20B-10MEKD	1/20	8.35	354	207	105	28.9
HC-RF103G2 HC-RFS103G2	1.0	BL3-29B-10MEKD	1/29	6.45	354	207	105	28.9
HC-RF103G2 HC-RFS103G2	1.0	BL3-45B-10MEKD	1/45	5.48	364	217	115	28.9
HC-RF153G2 HC-RFS153G2	1.5	BL3-09B-15MEKD	1/9	6.68	375	203	101	30
HC-RF153G2 HC-RFS153G2	1.5	BL3-20B-15MEKD	1/20	8.75	379	207	105	30
HC-RF153G2 HC-RFS153G2	1.5	BL3-29B-15MEKD	1/29	6.85	379	207	105	30
HC-RF203G2 HC-RFS203G2	2.0	BL3-09B-20MEKD	1/9	7.08	400	203	101	31.2
HC-RF203G2 HC-RFS203G2	2.0	BL3-20B-20MEKD	1/20	9.15	404	207	105	31.2

(Note)[Unit: mm]

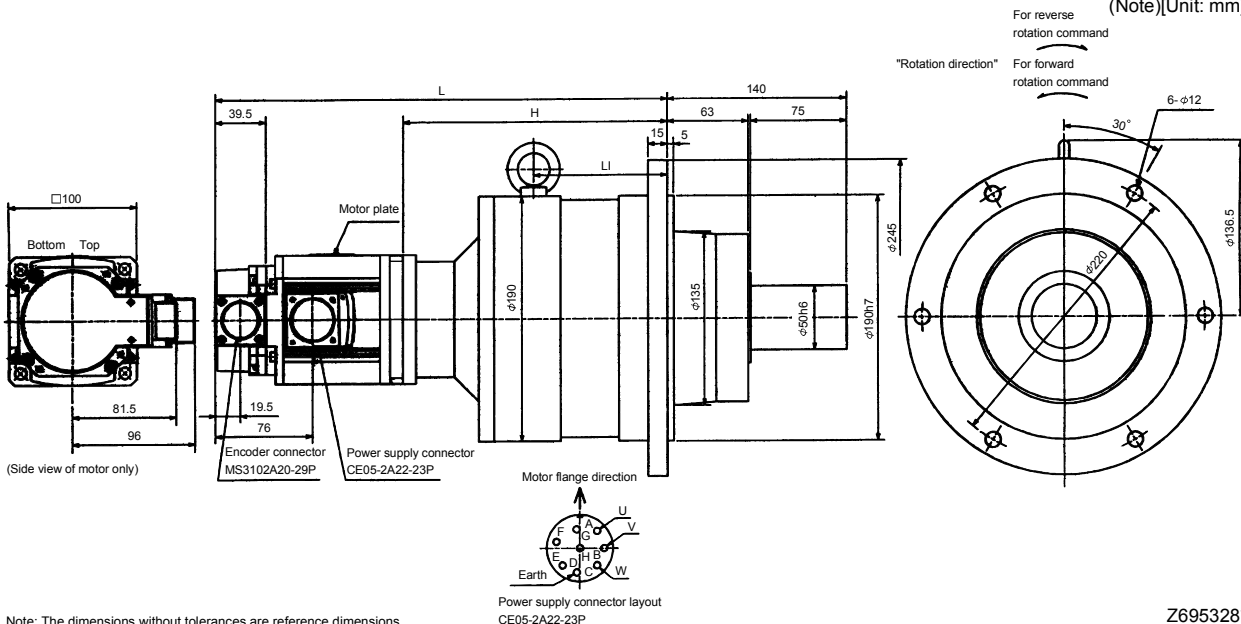

Note: The dimensions without tolerances are reference dimensions.

Z695328*

7. OUTLINE DIMENSION DRAWINGS

Model	Output [kW]	Reduction Gear Model	Reduction Ratio	Inertia Moment $J[\times 10^{-4} \text{kg} \cdot \text{m}^2]$	Variable Dimensions			Mass [kg]
					L	H	LI	
HC-RF153G2 HC-RFS153G2	1.5	BL4-45B-15MEKD	1/45	8.55	410	238	136	50
HC-RF203G2 HC-RFS203G2	2.0	BL4-29B-20MEKD	1/29	12.7	425	228	126	51.2
HC-RF203G2 HC-RFS203G2	2.0	BL4-45B-20MEKD	1/45	8.98	435	238	136	51.2

(Note)[Unit: mm]

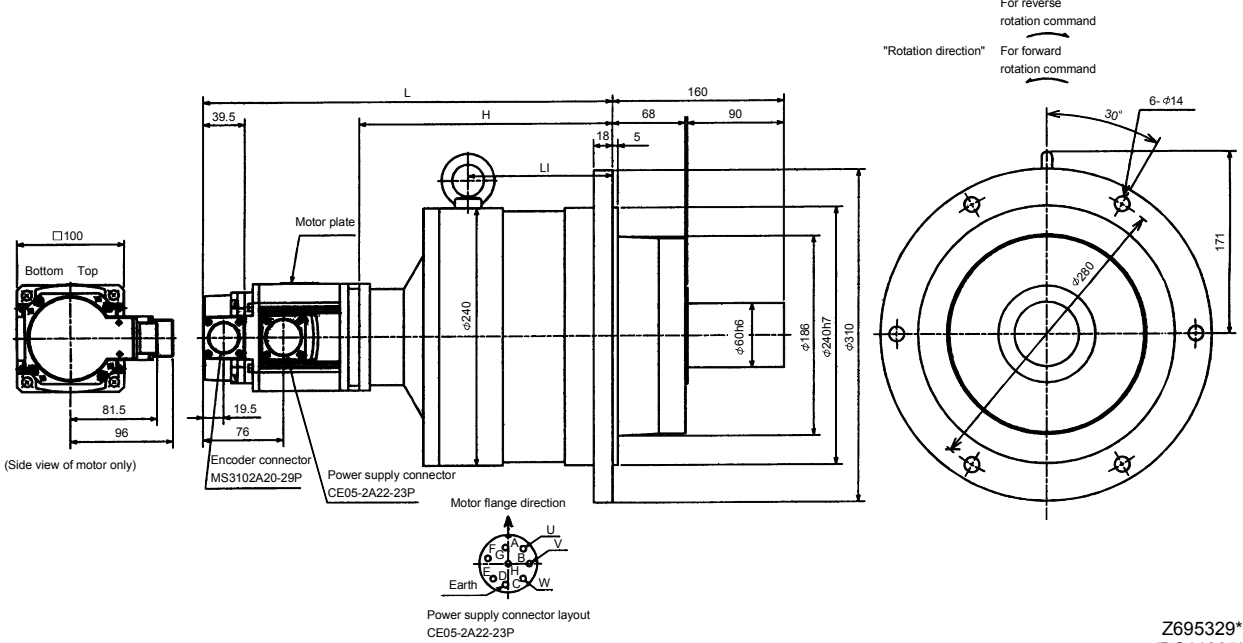

Z695329*
(BC11865*)

Note: The dimensions without tolerances are reference dimensions.

Model	Output [kW]	Reduction Gear Model	Reduction Ratio	Inertia Moment $J[\times 10^{-4} \text{kg} \cdot \text{m}^2]$	Mass [kg]

(Note)[Unit: mm]

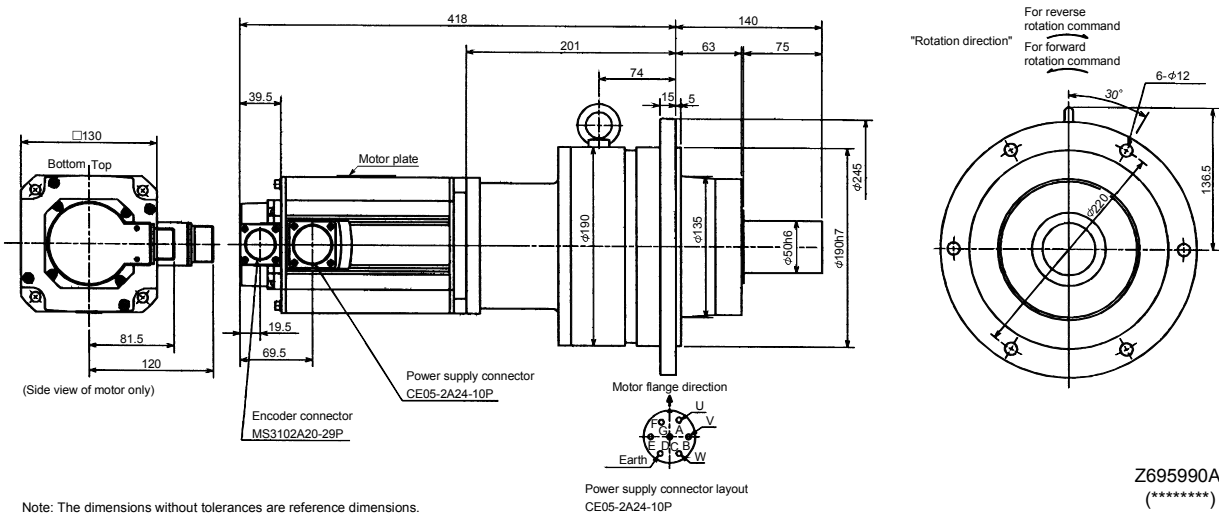

Z695990A
(*****)

Note: The dimensions without tolerances are reference dimensions.

7. OUTLINE DIMENSION DRAWINGS

Model	Output [kW]	Reduction Gear Model	Reduction Ratio	Inertia Moment $J[\times 10^{-4} \text{kg} \cdot \text{m}^2]$	Variable Dimensions			Mass [kg]
					L	H	LI	
HC-RF353G2 HC-RFS353G2	3.5	BL4-09B-35MEKD	1/9	21.1	470	253	126	57
HC-RF353G2 HC-RFS353G2	3.5	BL4-20B-35MEKD	1/20	28.8	470	253	126	57
HC-RF353G2 HC-RFS353G2	3.5	BL4-29B-35MEKD	1/29	22.0	470	253	126	57
HC-RF503G2 HC-RFS503G2	5.0	BL4-05B-50MEKD	1/5	32.4	495	221	94	52
HC-RF503G2 HC-RFS503G2	5.0	BL4-09B-50MEKD	1/9	24.5	527	253	126	62
HC-RF503G2 HC-RFS503G2	5.0	BL4-20B-50MEKD	1/20	32.2	527	253	126	62

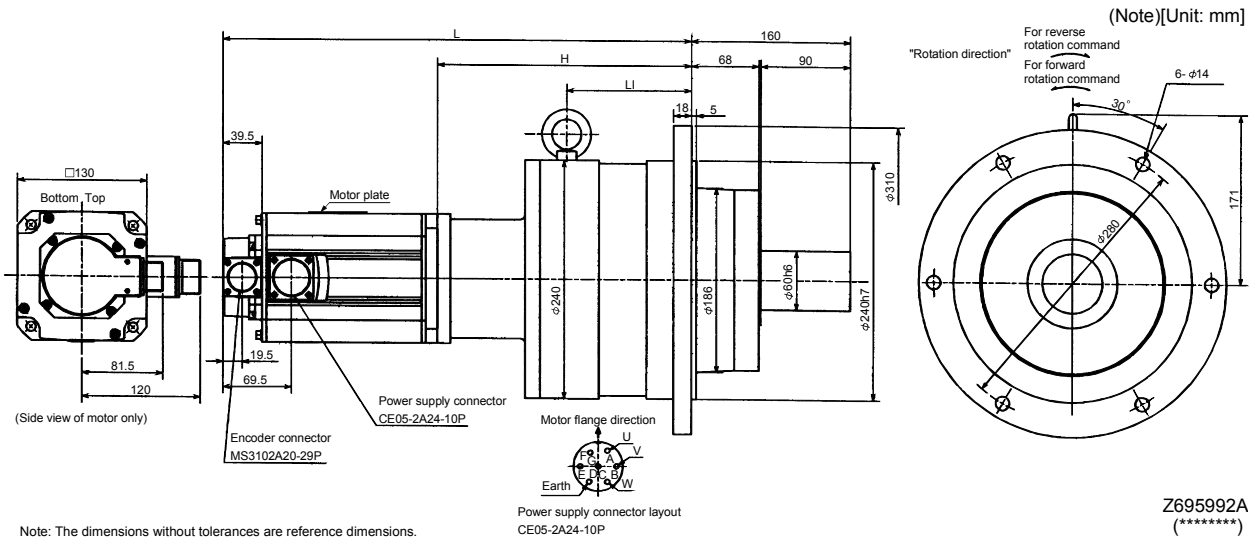

Note: The dimensions without tolerances are reference dimensions.

(b) With electromagnetic brake

Model	Output [kW]	Reduction Gear Model	Reduction Ratio	Inertia Moment $J[\times 10^{-4} \text{kg} \cdot \text{m}^2]$	Variable Dimensions		Brake static friction torque [N · m]	Mass [kg]
					L	H		
HC-RF103BG2 HC-RFS103BG2	1.0	BL2-05B-10MEKD	1/5	5.3	339	154	7	14
HC-RF103BG2 HC-RFS103BG2	1.0	BL2-09B-10MEKD	1/9	4.95	351	166	7	14
HC-RF153BG2 HC-RFS153BG2	1.5	BL2-05B-15MEKD	1/5	5.7	364	154	7	15.1
HC-RF203BG2 HC-RFS203BG2	2.0	BL2-05B-20MEKD	1/5	6.1	389	154	7	16.3

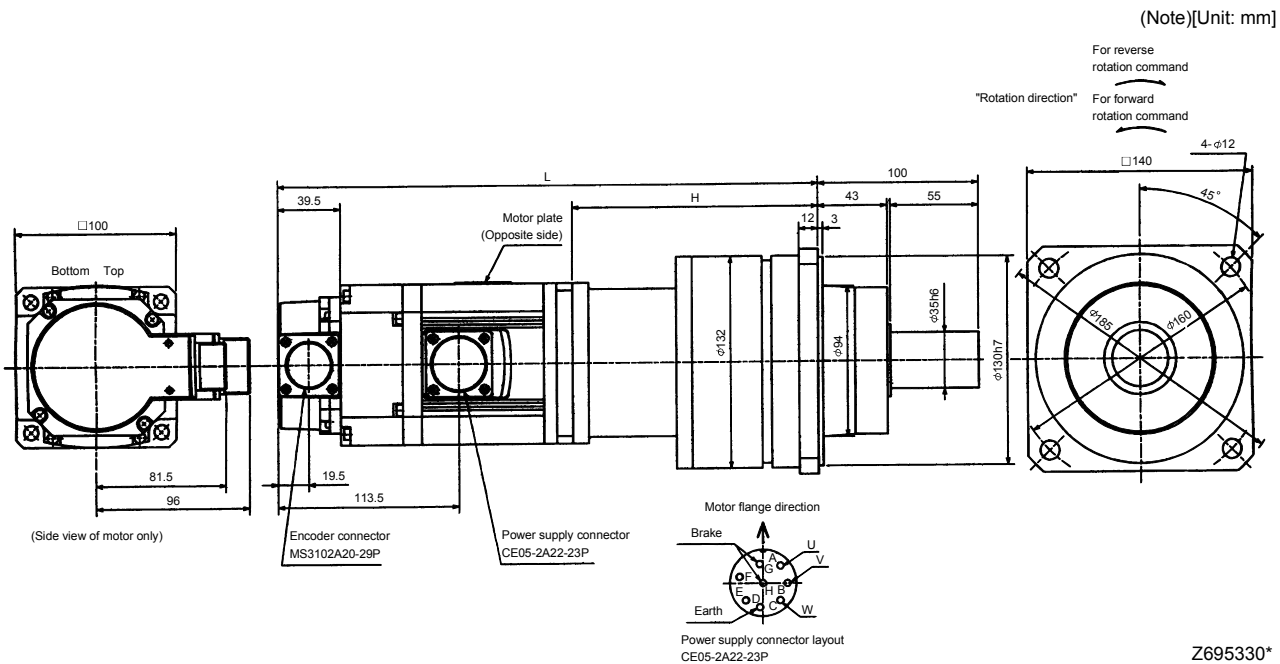

Note: The dimensions without tolerances are reference dimensions.

7. OUTLINE DIMENSION DRAWINGS

Model	Output [kW]	Reduction Gear Model	Reduction Ratio	Inertia Moment $J[\times 10^{-4} \text{kg} \cdot \text{m}^2]$	Variable Dimensions			Brake static friction torque [N · m]	Mass [kg]
					L	H	LI		
HC-RF103BG2 HC-RFS103BG2	1.0	BL3-20B-10MEKD	1/20	8.7	392	207	105	7	31
HC-RF103BG2 HC-RFS103BG2	1.0	BL3-29B-10MEKD	1/29	6.8	392	207	105	7	31
HC-RF103BG2 HC-RFS103BG2	1.0	BL3-45B-10MEKD	1/45	5.83	402	217	115	7	31
HC-RF153BG2 HC-RFS153BG2	1.5	BL3-09B-15MEKD	1/9	7.03	413	203	101	7	32.1
HC-RF153BG2 HC-RFS153BG2	1.5	BL3-20B-15MEKD	1/20	9.1	417	207	105	7	32.1
HC-RF153BG2 HC-RFS153BG2	1.5	BL3-29B-15MEKD	1/29	7.2	417	207	105	7	32.1
HC-RF203BG2 HC-RFS203BG2	2.0	BL3-09B-20MEKD	1/9	7.43	438	203	101	7	33.3
HC-RF203BG2 HC-RFS203BG2	2.0	BL3-20B-20MEKD	1/20	9.5	442	207	105	7	33.3

(Note)[Unit: mm]

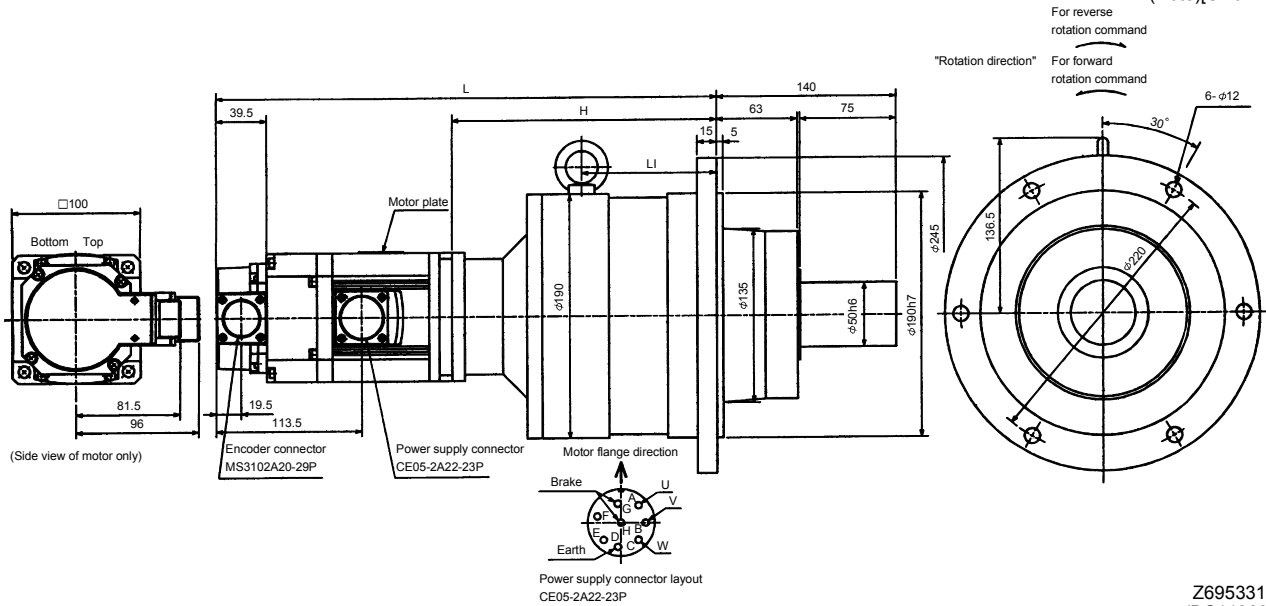

Z695331*
(BC11869*)

Note: The dimensions without tolerances are reference dimensions.

Model	Output [kW]	Reduction Gear Model	Reduction Ratio	Inertia Moment $J[\times 10^{-4} \text{kg} \cdot \text{m}^2]$	Variable Dimensions			Brake static friction torque [N · m]	Mass [kg]
					L	H	LI		
HC-RF153BG2 HC-RFS153BG2	1.5	BL4-45B-15MEKD	1/45	8.9	448	238	136	7	52.1
HC-RF203BG2 HC-RFS203BG2	2.0	BL4-29B-20MEKD	1/29	13.1	463	228	126	7	53.3
HC-RF203BG2 HC-RFS203BG2	2.0	BL4-45B-20MEKD	1/45	9.3	473	238	136	7	53.3

(Note)[Unit: mm]

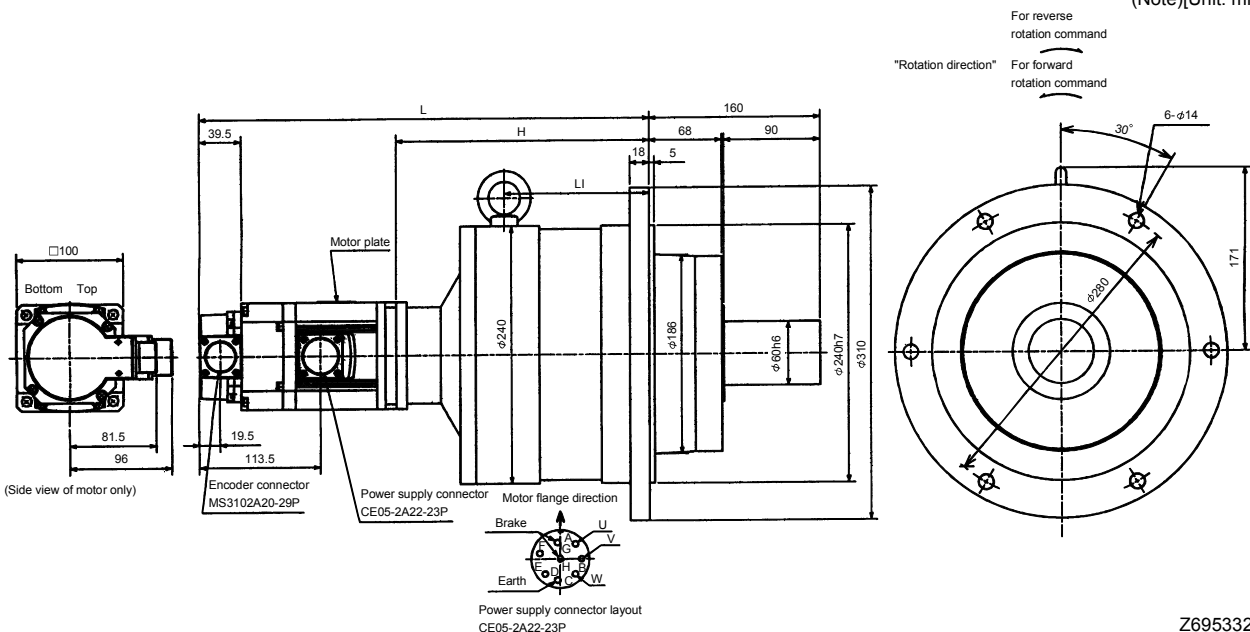

Z695332*
(BC11870*)

Note: The dimensions without tolerances are reference dimensions.

7. OUTLINE DIMENSION DRAWINGS

Model	Output [kW]	Reduction Gear Model	Reduction Ratio	Brake static friction torque [N · m]	Inertia Moment $J[\times 10^{-4} \text{kg} \cdot \text{m}^2]$	Mass [kg]
HC-RF353BG2 HC-RFS353BG2	3.5	BL3-05B-35MEKD	1/5	16.7	20.8	33

(Note)[Unit: mm]

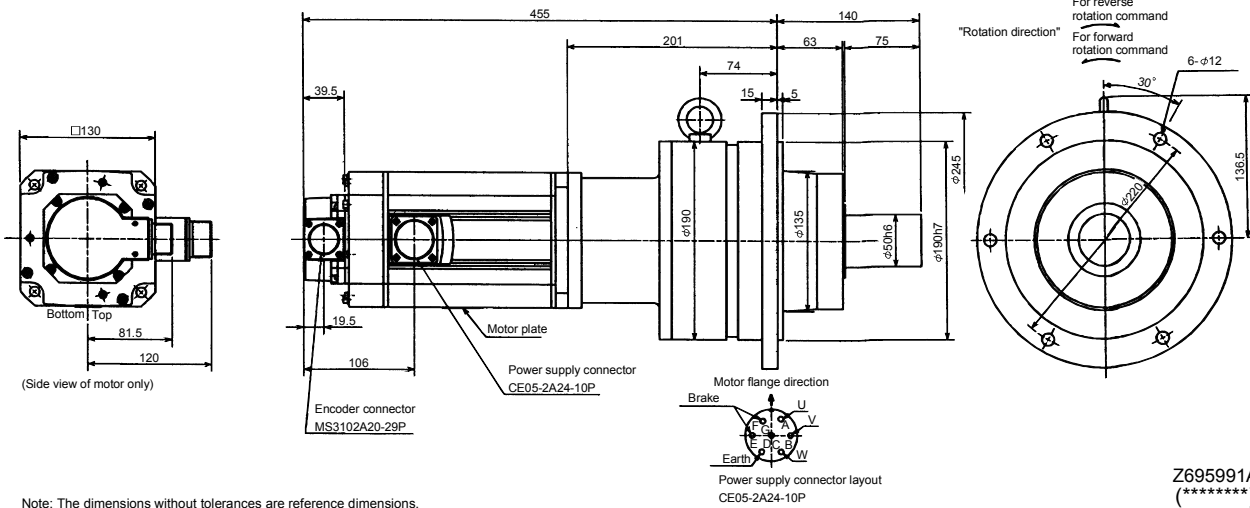

Note: The dimensions without tolerances are reference dimensions.

Z695991A
(*****)

Model	Output [kW]	Reduction Gear Model	Reduction Ratio	Variable Dimensions			Brake static friction torque [N · m]	Inertia Moment $J[\times 10^{-4} \text{kg} \cdot \text{m}^2]$	Mass [kg]
				L	H	LI			
HC-RF353BG2 HC-RFS353BG2	3.5	BL4-09B-35MEKD	1/9	507	253	126	16.7	23.1	60
HC-RF353BG2 HC-RFS353BG2	3.5	BL4-20B-35MEKD	1/20	507	253	126	16.7	30.8	60
HC-RF353BG2 HC-RFS353BG2	3.5	BL4-29B-35MEKD	1/29	507	253	126	16.7	22.0	60
HC-RF503BG2 HC-RFS503BG2	5.0	BL4-05B-50MEKD	1/5	532	221	94	16.7	34.4	56
HC-RF503BG2 HC-RFS503BG2	5.0	BL4-09B-50MEKD	1/9	564	253	126	16.7	26.5	66
HC-RF503BG2 HC-RFS503BG2	5.0	BL4-20B-50MEKD	1/20	564	253	126	16.7	34.2	66

(Note)[Unit: mm]

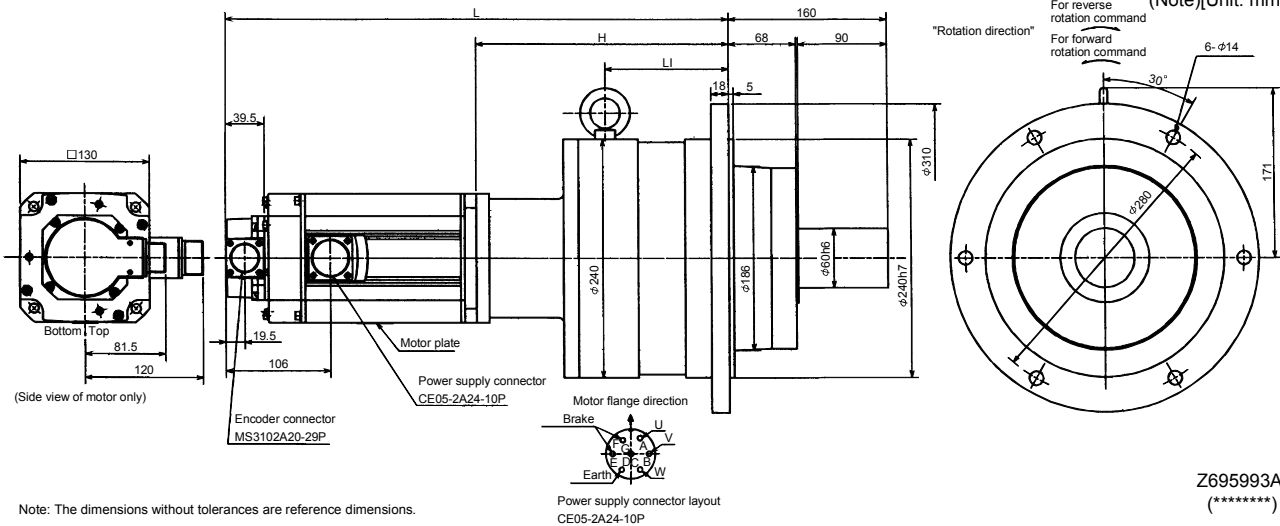

Note: The dimensions without tolerances are reference dimensions.

Z695993A
(*****)

7. OUTLINE DIMENSION DRAWINGS

7.1.5 HC-UF 2000r/min · HC-UFS 2000r/min series

(1) Standard (without electromagnetic brake)

Model	Output [kW]	Inertia Moment $J[\times 10^{-4} \text{kg} \cdot \text{m}^2]$	Mass [kg]
HC-UF72 HC-UFS72	0.75	10.4	8

(Note)[Unit: mm]

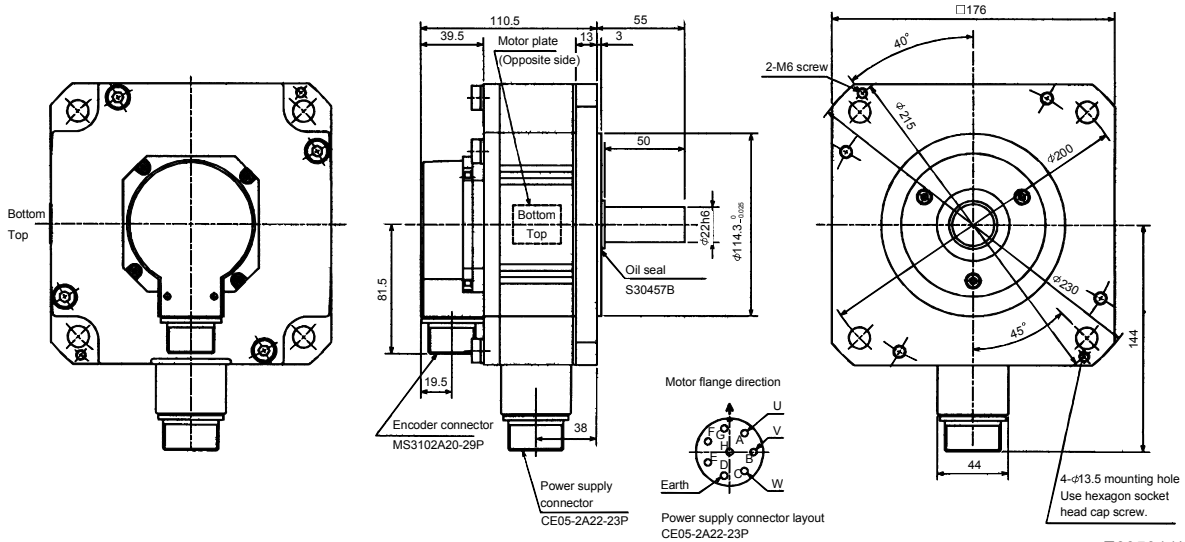

Note: The dimensions without tolerances are reference dimensions.

Z695911*
(BC11711*)

Model	Output [kW]	Inertia Moment $J[\times 10^{-4} \text{kg} \cdot \text{m}^2]$	Mass [kg]
HC-UF152 HC-UFS152	1.5	22.1	11

(Note)[Unit: mm]

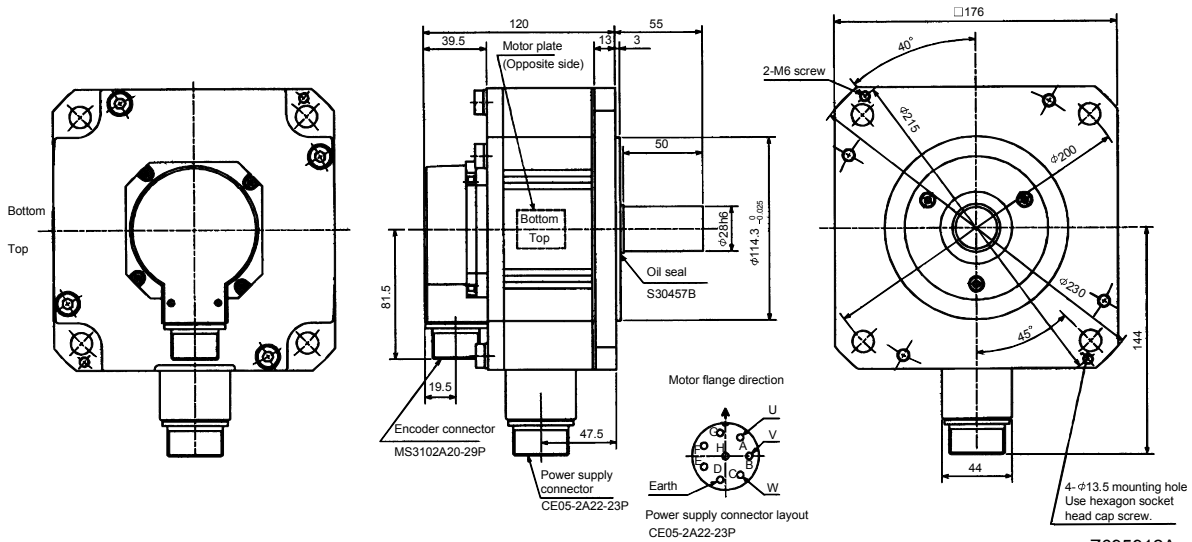

Note: The dimensions without tolerances are reference dimensions.

Z695912A
(BC11712*)

7. OUTLINE DIMENSION DRAWINGS

Model		Output [kW]	Variable Dimensions		Inertia Moment $J[\times 10^{-4} \text{ kg} \cdot \text{m}^2]$	Mass [kg]
			L	KL		
HC-UF202	HC-UFS202	2.0	118	42.5	38.2	16
HC-UF352	HC-UFS352	3.5	142	66.5	76.5	20
HC-UF502	HC-UFS502	5.0	166	90.5	115	24

(Note)[Unit: mm]

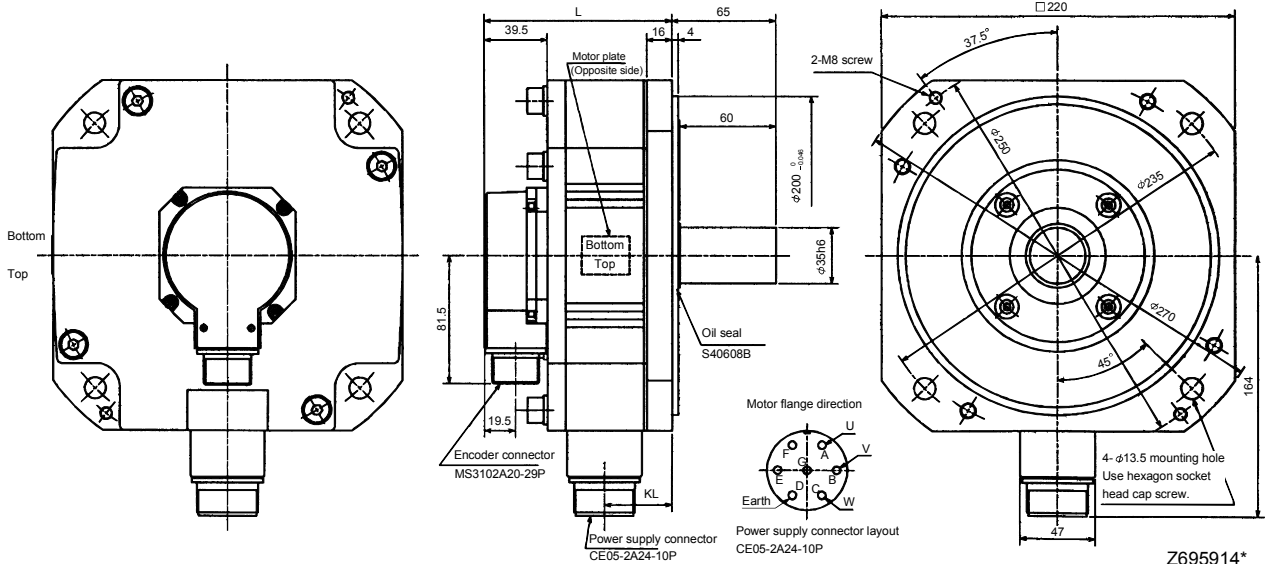

Note: The dimensions without tolerances are reference dimensions.

Z695914*
(BC11713* BC12764*)

(2) With electromagnetic brake

Model		Output [kW]	Brake static friction torque [N · m]	Inertia Moment $J[\times 10^{-4} \text{ kg} \cdot \text{m}^2]$	Mass [kg]
HC-UF72B	HC-UFS72B	0.75	8.5	12.4	10

(Note)[Unit: mm]

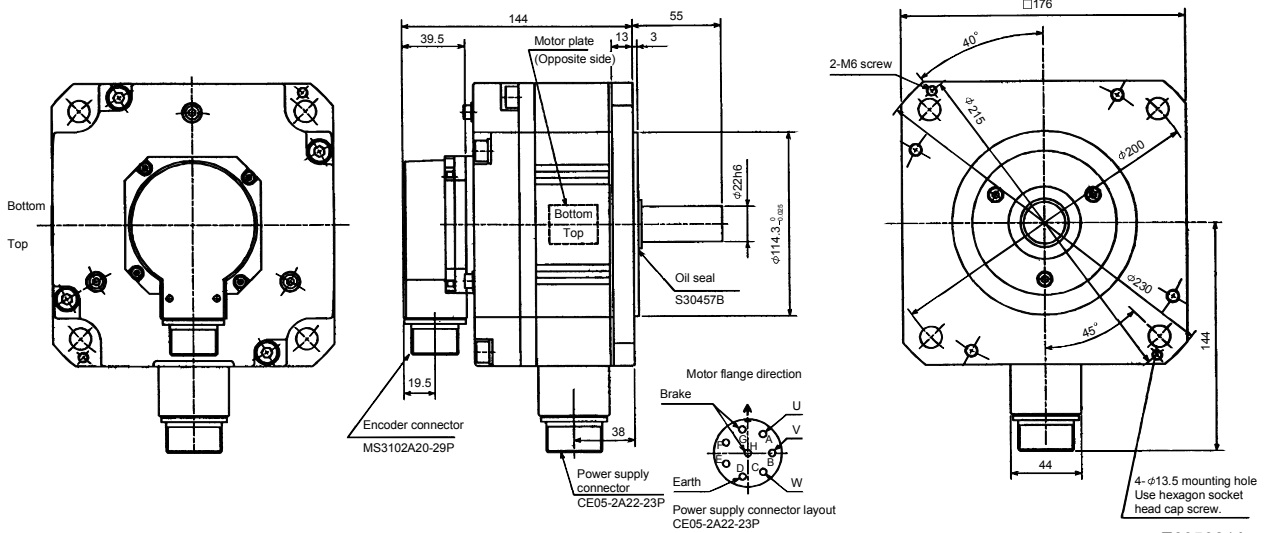

Note: The dimensions without tolerances are reference dimensions.

Z695981A
(BC11714*)

7. OUTLINE DIMENSION DRAWINGS

Model	Output [kW]	Brake static friction torque [N · m]	Inertia Moment $J[\times 10^{-4} \text{kg} \cdot \text{m}^2]$	Mass [kg]
HC-UF152B HC-UFS152B	1.5	8.5	24.1	13

(Note)[Unit: mm]

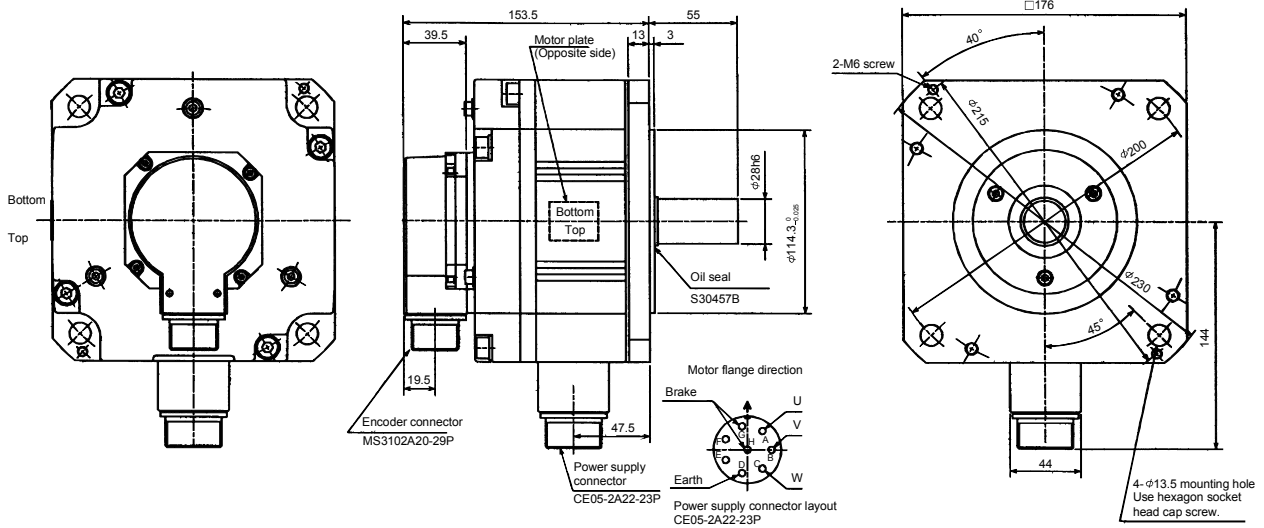

Z695982B
(BC11715*)

Note: The dimensions without tolerances are reference dimensions.

Model	Output [kW]	Variable Dimensions		Brake static friction torque [N · m]	Inertia Moment $J[\times 10^{-4} \text{kg} \cdot \text{m}^2]$	Mass [kg]
		L	KL			
HC-UF202B HC-UFS202B	2.0	161	42.5	43.1	46.8	22
HC-UF352B HC-UFS352B	3.5	185	66.5	43.1	85.1	26
HC-UF502B HC-UFS502B	5.0	209	90.5	43.1	123.6	30

(Note)[Unit: mm]

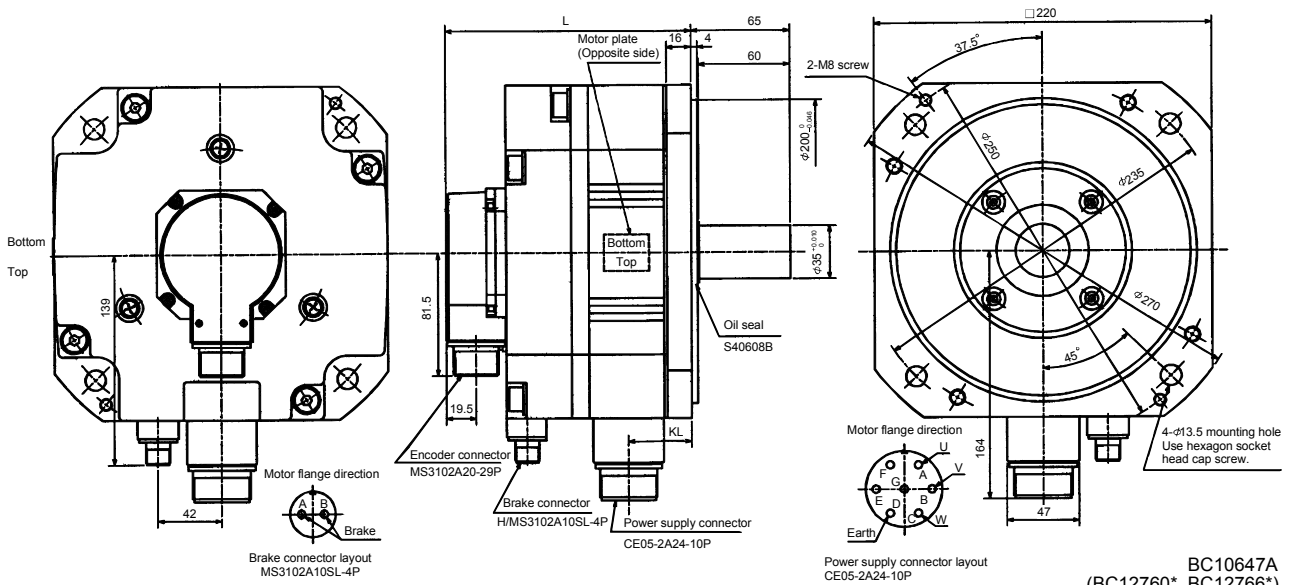

BC10647A
(BC12760* BC12766*)

Note: The dimensions without tolerances are reference dimensions.

7. OUTLINE DIMENSION DRAWINGS

7.1.6 HC-UF 3000r/min series

(1) Standard (without electromagnetic brake)

Model	Output [W]	Inertia Moment $J[\times 10^{-4} \text{kg} \cdot \text{m}^2]$	Mass [kg]
HC-UF13	100	0.066	0.8

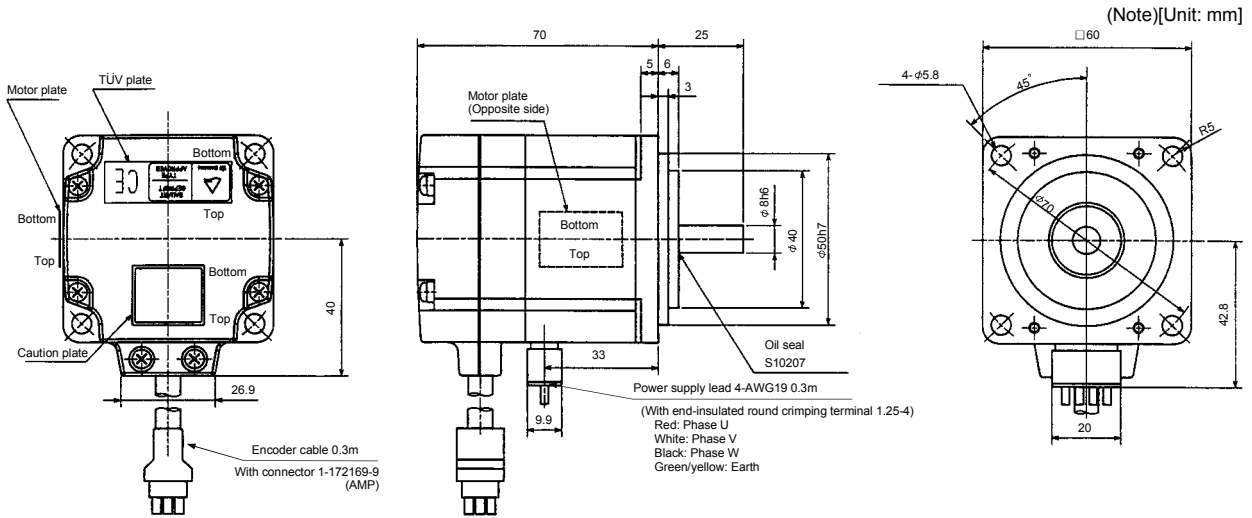

Note: The dimensions without tolerances are reference dimensions.

Model	Output [W]	Variable Dimensions		Inertia Moment $J[\times 10^{-4} \text{kg} \cdot \text{m}^2]$	Mass [kg]
		L	KL		
HC-UF23	200	77	43.8	0.241	1.5
HC-UF43	400	92	58.8	0.365	1.7

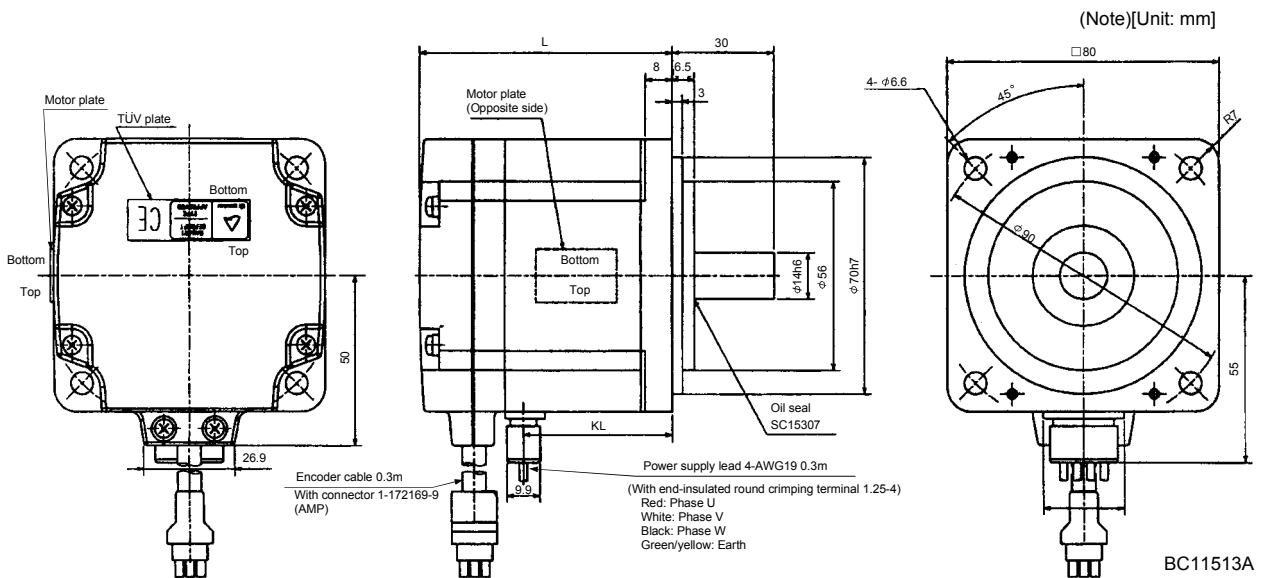

Note: The dimensions without tolerances are reference dimensions.

7. OUTLINE DIMENSION DRAWINGS

Model	Output [W]	Inertia Moment $J[\times 10^{-4} \text{kg} \cdot \text{m}^2]$	Mass [kg]
HC-UF73	750	5.9	5.0

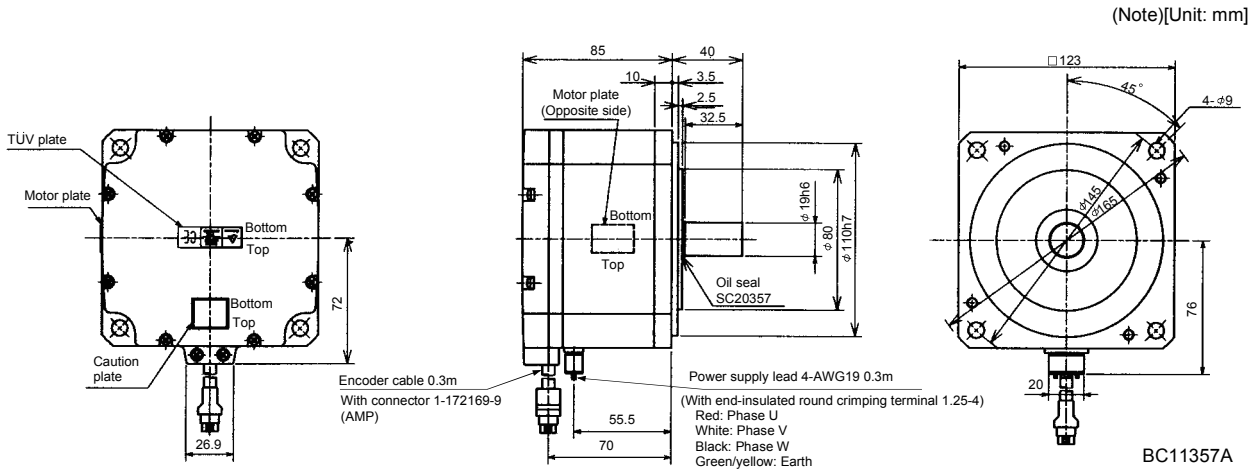

Note: The dimensions without tolerances are reference dimensions.

(2) With electromagnetic brake

Model	Output (W)	Brake static friction torque [N · m]	Inertia Moment $J[\times 10^{-4} \text{kg} \cdot \text{m}^2]$	Mass [kg]
HC-UF13B	100	0.32	0.074	1.2

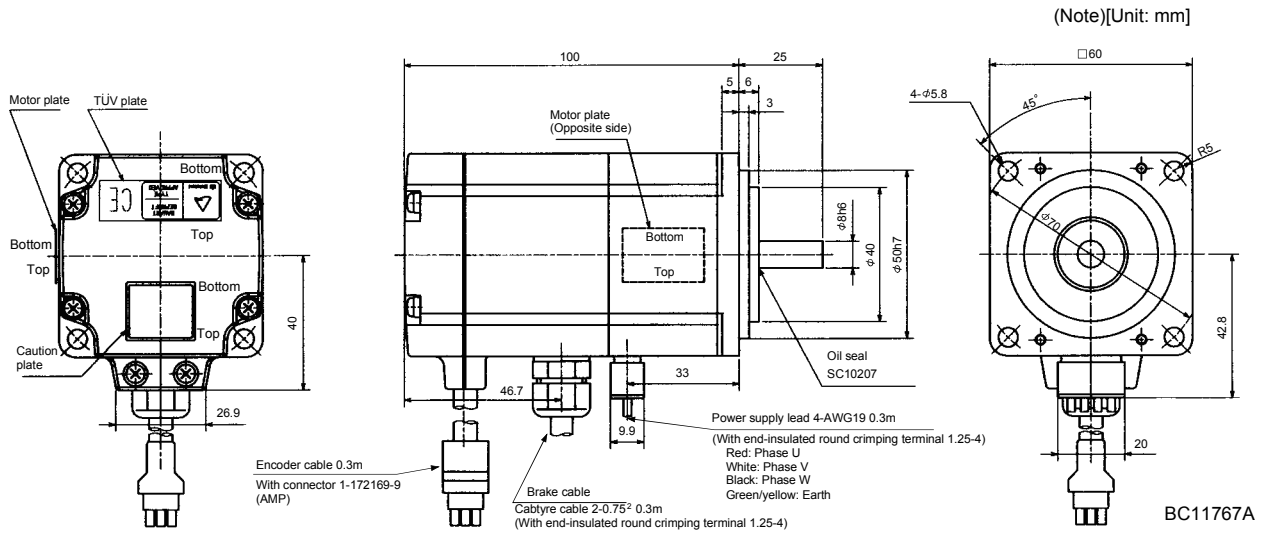

Note: The dimensions without tolerances are reference dimensions.

7. OUTLINE DIMENSION DRAWINGS

Model	Output [W]	Variable Dimensions		Brake static friction torque [N · m]	Inertia Moment J [$\times 10^{-4}$ kg · m ²]	Mass [kg]
		L	KL			
HC-UF23B	200	111	43.8	1.3	0.323	2.2
HC-UF43B	400	126	58.8	1.3	0.447	2.4

(Note)[Unit: mm]

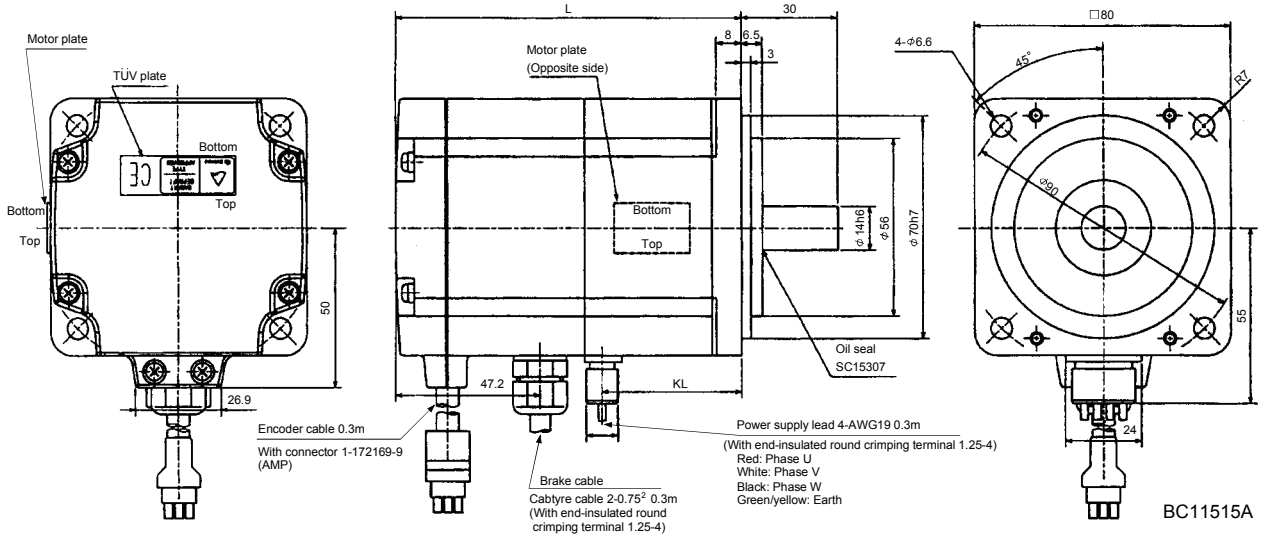

Note: The dimensions without tolerances are reference dimensions.

Model	Output [W]	Brake static friction torque [N · m]	Inertia Moment J [$\times 10^{-4}$ kg · m ²]	Mass [kg]
HC-UF73B	750	2.4	6.1	6.2

(Note)[Unit: mm]

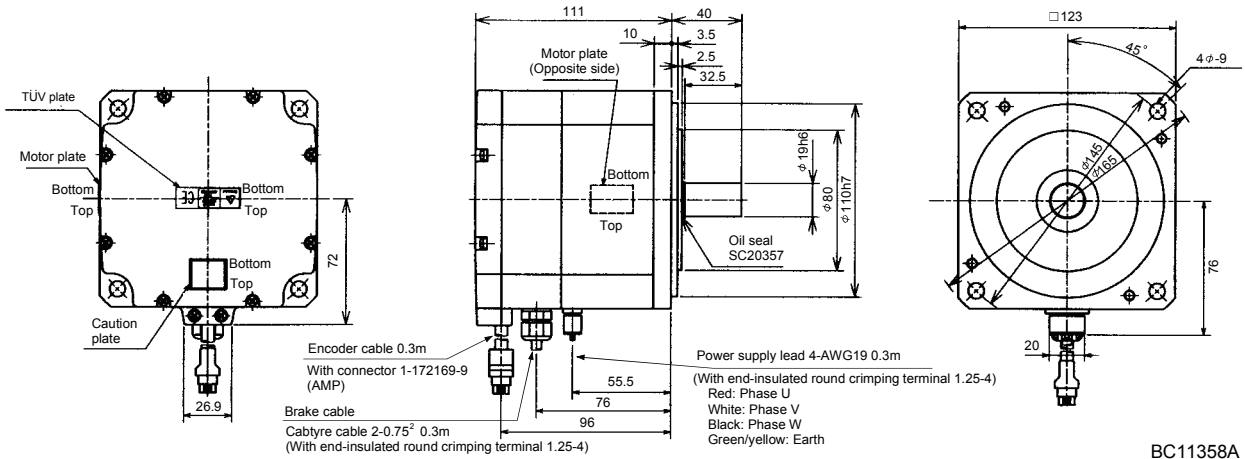

Note: The dimensions without tolerances are reference dimensions.

7. OUTLINE DIMENSION DRAWINGS

7.1.7 HC-UF3000r/min, HC-UFS3000r/min series with IP65-compliant connectors

(1) Without electromagnetic brake

Model		Output [W]	Inertia Moment $J[\times 10^{-4} \text{ kg} \cdot \text{m}^2]$	Mass [kg]
HC-UF13-S1	HC-UFS13-S1	100	0.066	0.8

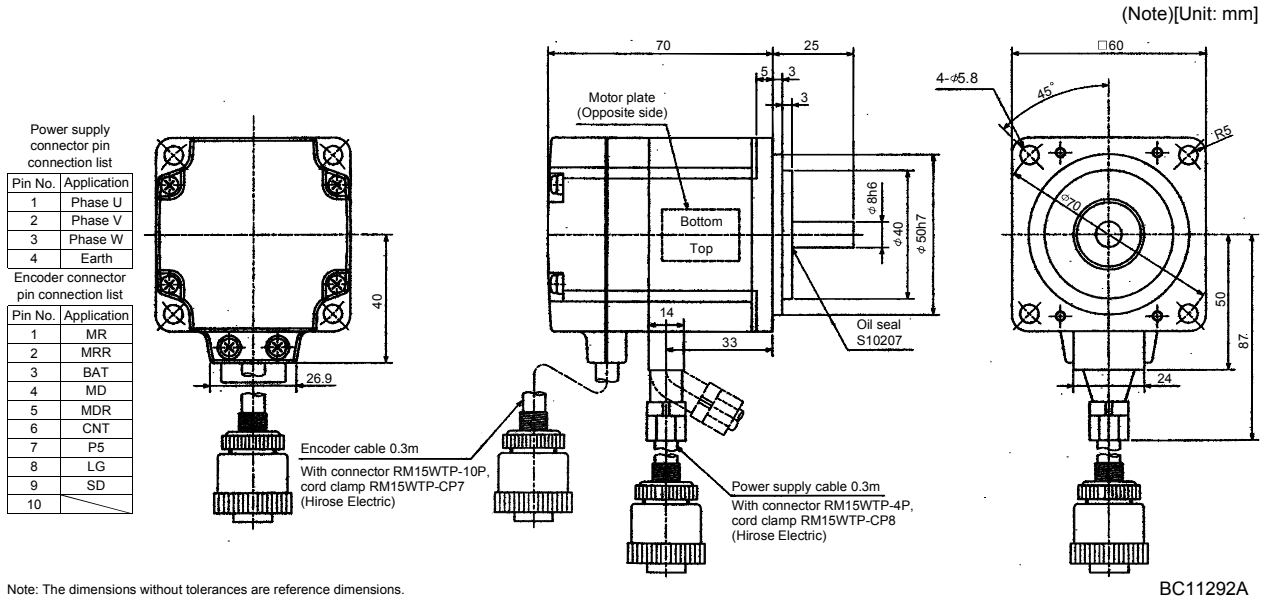

Note: The dimensions without tolerances are reference dimensions.

Model		Output [W]	Variable Dimensions		Inertia Moment $J[\times 10^{-4} \text{ kg} \cdot \text{m}^2]$	Mass [kg]
			L	KL		
HC-UF23-S1	HC-UFS23-S1	200	75	44	0.241	1.5
HC-UF43-S1	HC-UFS43-S1	400	90	59	0.365	1.7

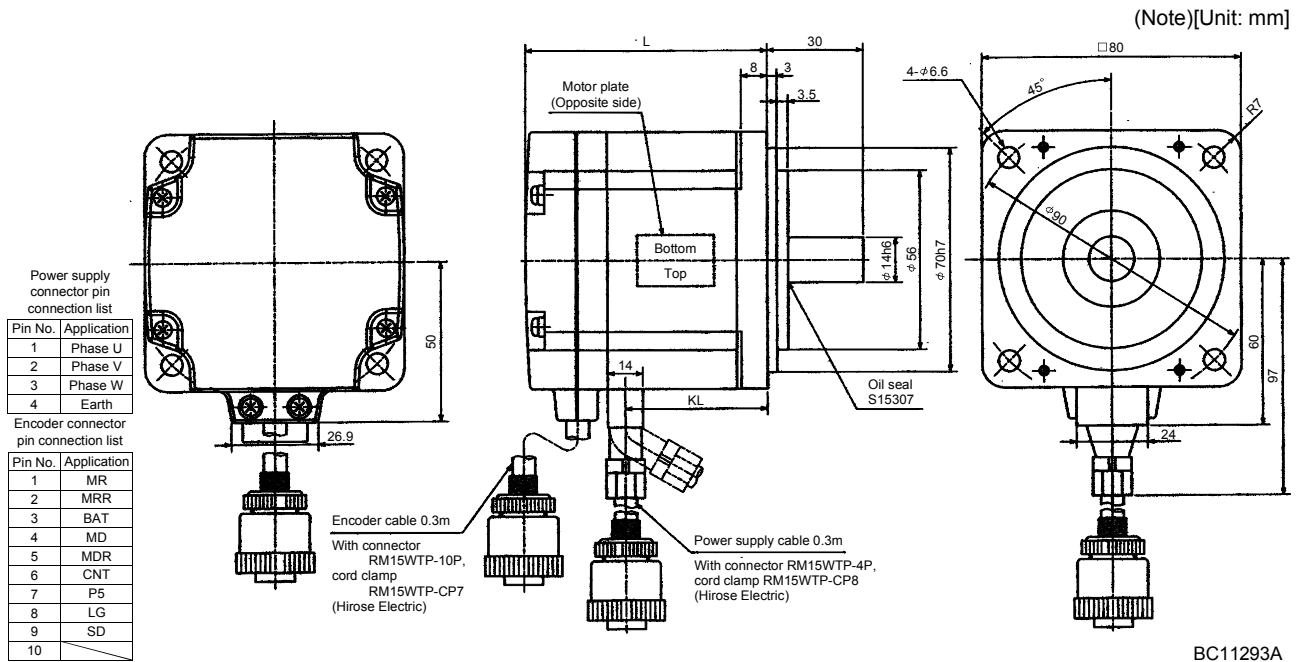

Note: The dimensions without tolerances are reference dimensions.

7. OUTLINE DIMENSION DRAWINGS

Model		Output [W]	Inertia Moment $J[\times 10^{-4} \text{kg} \cdot \text{m}^2]$	Mass [kg]
HC-UF73-S1	HC-UFS73-S1	750	5.9	5.0

(Note)[Unit: mm]

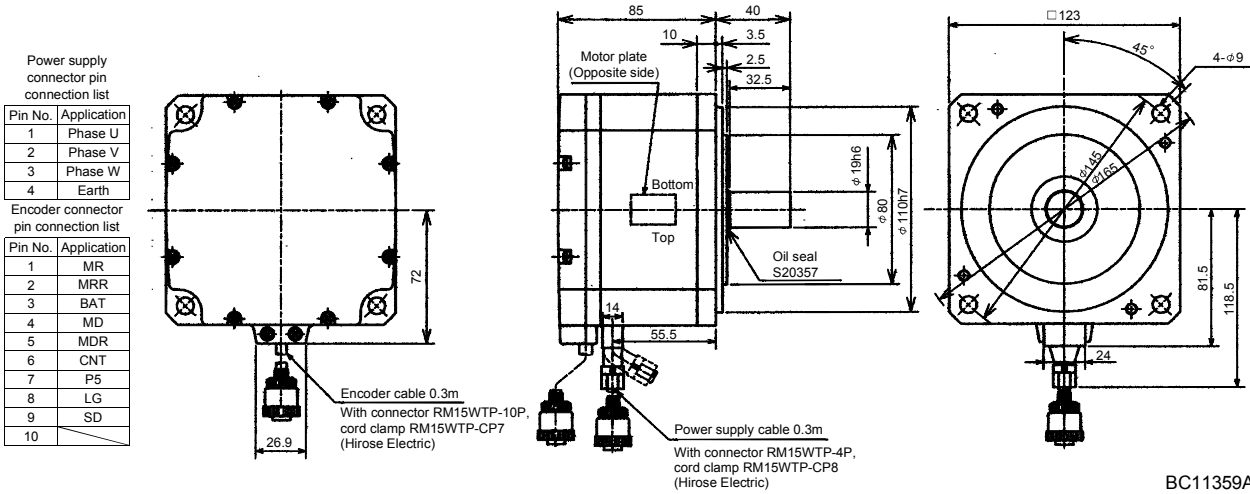

Note: The dimensions without tolerances are reference dimensions.

(2) With electromagnetic brake

Model		Output [W]	Brake static friction torque [N · m]	Inertia Moment $J[\times 10^{-4} \text{kg} \cdot \text{m}^2]$	Mass [kg]
HC-UF13B-S1	HC-UFS13B-S1	100	0.32	0.074	1.2

(Note)[Unit: mm]

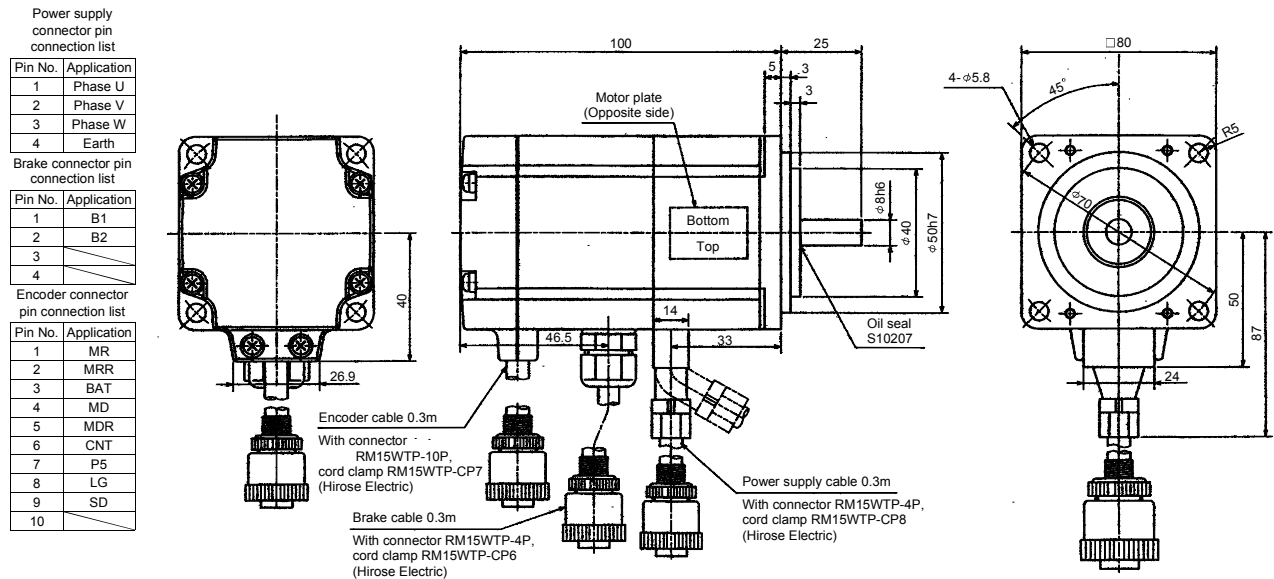

Note: The dimensions without tolerances are reference dimensions.

7. OUTLINE DIMENSION DRAWINGS

Model	Output [W]	Variable Dimensions		Brake static friction torque [N · m]	Inertia Moment $J[\times 10^{-4} \text{ kg} \cdot \text{m}^2]$	Mass [kg]
		L	KL			
HC-UF23B-S1 HC-UFS23B-S1	200	109	44	1.3	0.323	2.2
HC-UF43B-S1 HC-UFS43B-S1	400	124	59	1.3	0.447	2.4

(Note)[Unit: mm]

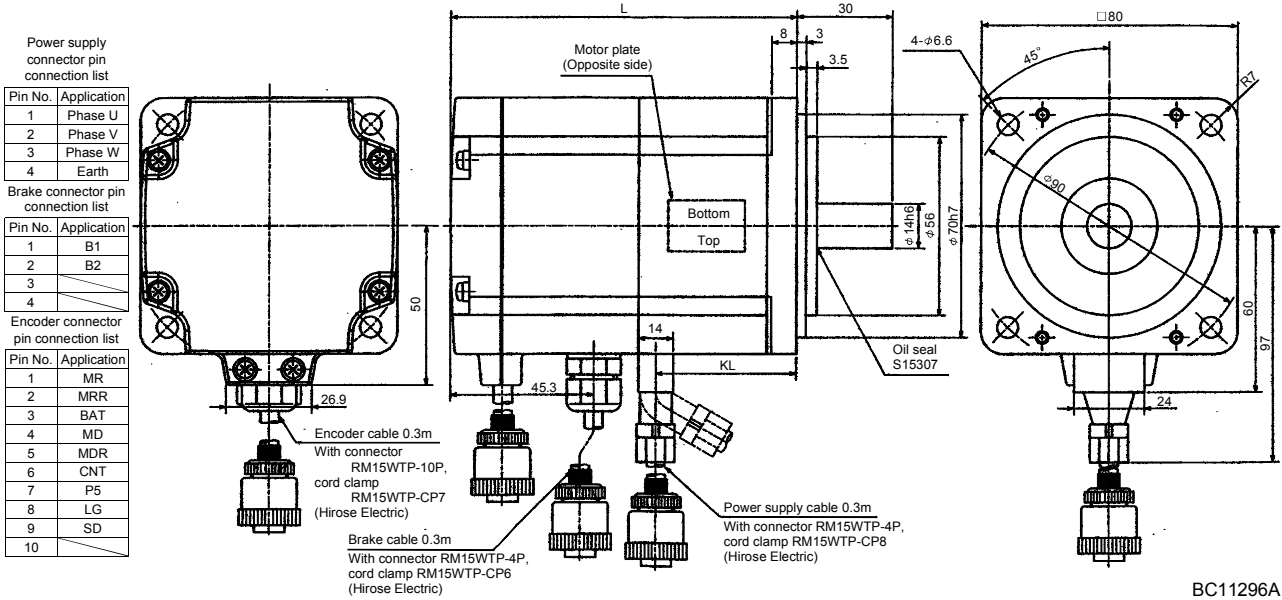

Note: The dimensions without tolerances are reference dimensions.

Model	Output [W]	Brake static friction torque [N · m]	Inertia Moment $J[\times 10^{-4} \text{ kg} \cdot \text{m}^2]$	Mass [kg]
HC-UF73B-S1 HC-UFS73B-S1	750	2.4	6.1	6.2

(Note)[Unit: mm]

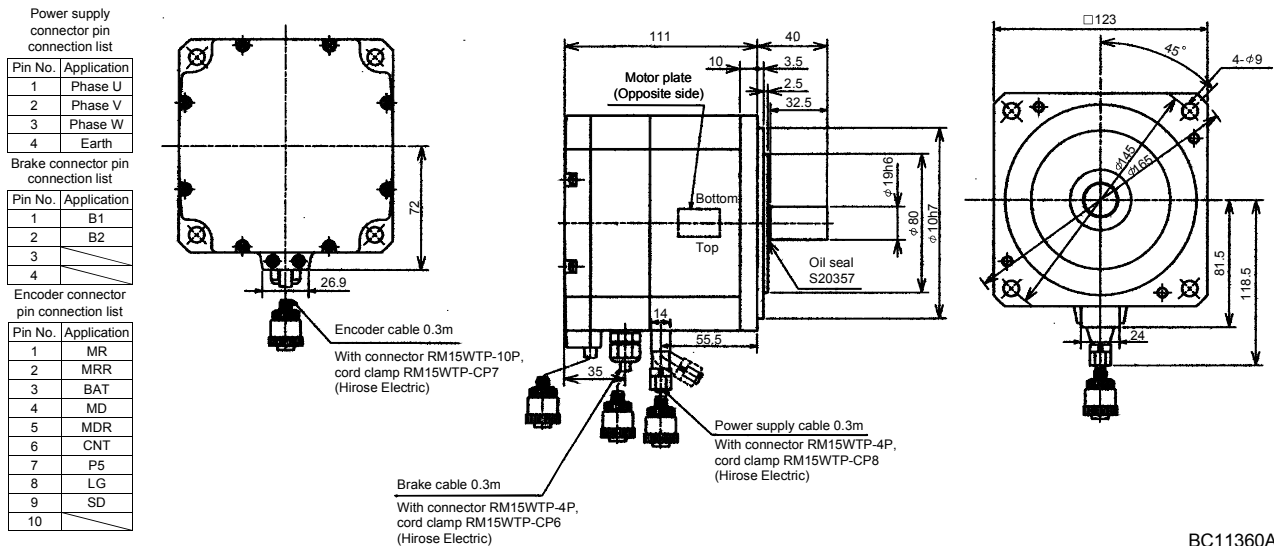

Note: The dimensions without tolerances are reference dimensions.

7. OUTLINE DIMENSION DRAWINGS

7.1.8 HA-LH series

(1) Standard (without electromagnetic brake)

Model	Variable Dimensions																	Inertia Moment J[$\times 10^{-4}$ kg \cdot m 2]	Oil Seal	Mass [kg]
	F	L	LA	LB	LC	LD	LG	LT	KL	KH	IE	IF	Hanger	E	LR	Q	S			
HA-LH11K2(-Y)	208	529	215	180	250	204	20	316	478	102	152	317	M10	3	85	80	42h6	118	S45629B	21
HA-LH15K2(-Y)	254	578	265	230	300	250	25	362	527	117	180	376	M12	5	110	100	55m6	290	S608295	17
HA-LH22K2(-Y)		430						592	395									30		

(Note1)[Unit: mm]

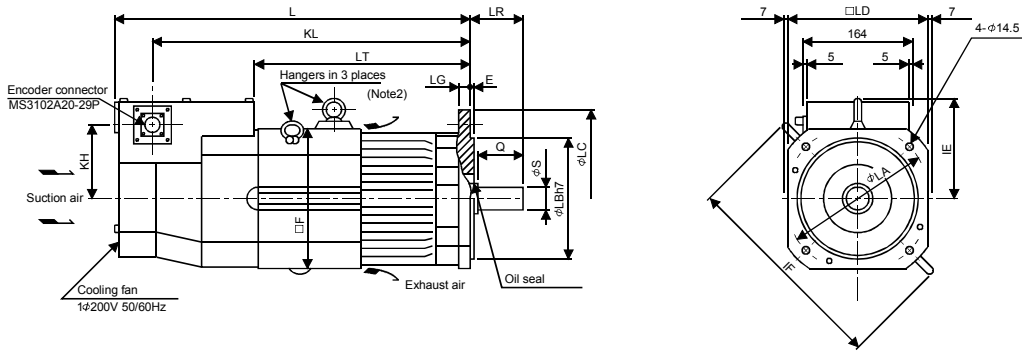

Note: 1. The dimensions without tolerances are reference dimensions.
 2. When using the motor without the hangers, plug the screw holes with the following bolts:
 HA-LH11K2: M10 \times 15mm max.
 HA-LH15K2, 22K2: M12 \times 18mm max.

Terminal Box of HA-LH11K2 to 22K2

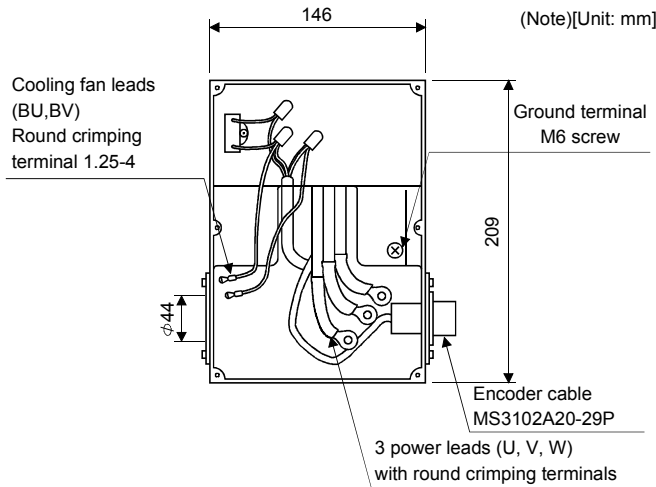

Note: The dimensions without tolerances are reference dimensions.

Power Connection Screw Size

Servo Motor	Power Connection Screw Size
HA-LH11K2	8-6
HA-LH15K2 \cdot 22K2	14-6

7. OUTLINE DIMENSION DRAWINGS

(2) EN · UL/C-UL Standard-Compliant model

Model	Output [kW]	Inertia Moment $J[\times 10^{-4} \text{kg} \cdot \text{m}^2]$	Mass [kg]
HA-LH11K2-EC	11	118	70

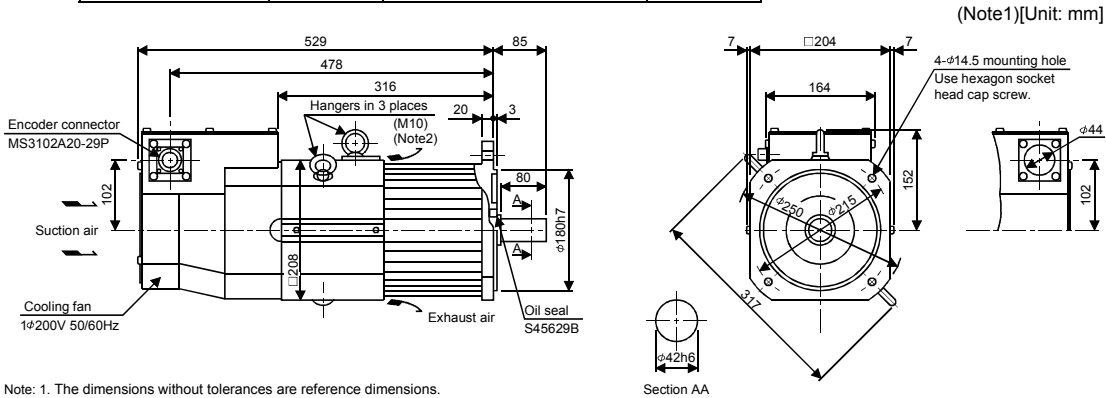

Note: 1. The dimensions without tolerances are reference dimensions.
2. When using the motor with hangers removed, plug screw holes with bolts M10×15 or less.

Model	Output [kW]	Variable Dimensions			Inertia Moment $J[\times 10^{-4} \text{kg} \cdot \text{m}^2]$	Mass [kg]
		L	KL	LT		
HA-LH15K2-EC	15	578	527	362	290	108
HA-LH22K2-EC	22	643	592	430	1160	135

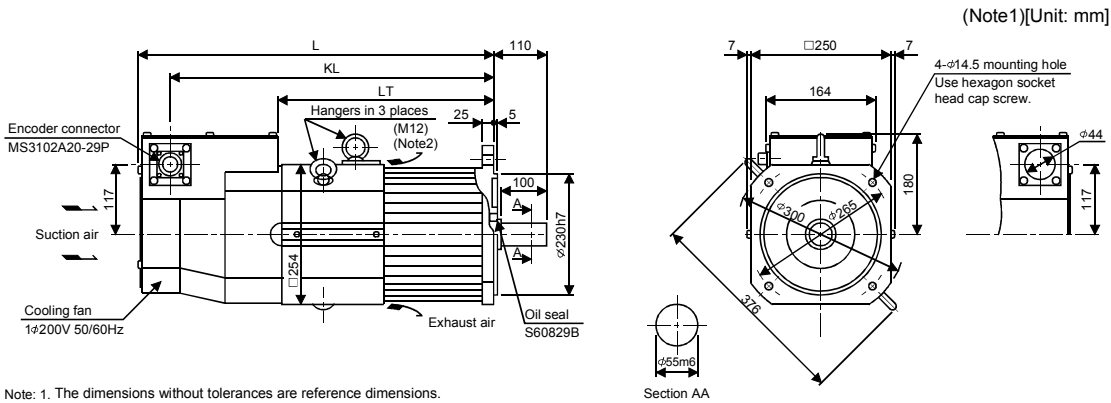

Note: 1. The dimensions without tolerances are reference dimensions.
2. When using the motor with hangers removed, plug screw holes with bolts M12×18 or less.

Terminal Box of HA-LH11K2-EC to 22K2-EC

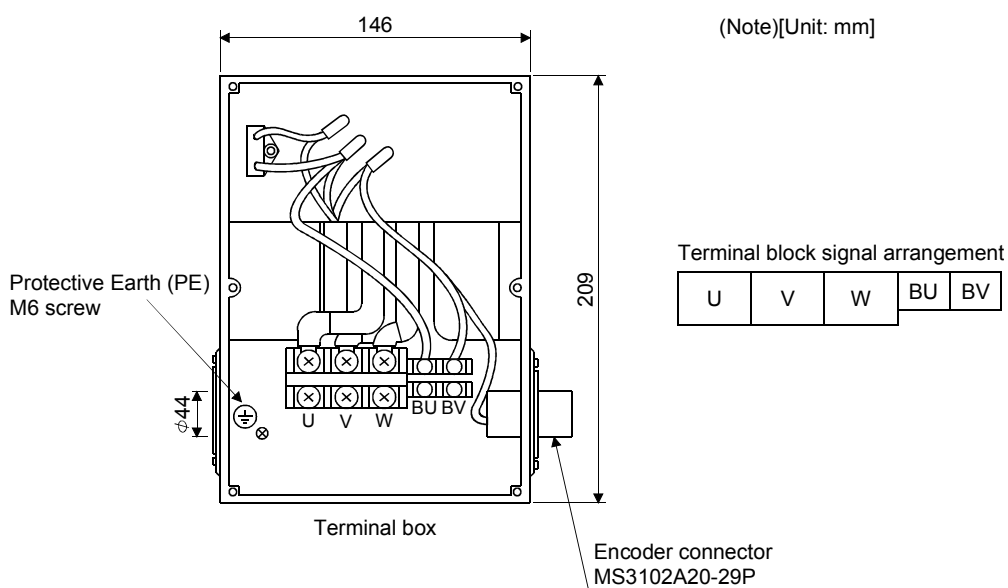

Note: The dimensions without tolerances are reference dimensions.

Model	Power Connection Screw Size	Fan Connection Screw Size
HA-LH11K2-EC	M6	M4
HA-LH15K2-EC · 22K2-EC	M8	M4

7. OUTLINE DIMENSION DRAWINGS

7.1.9 HC-AQ series

(1) Standard (without electromagnetic brake)

Model	Output [W]	Variable Dimensions		Inertia Moment $J[\times 10^{-4} \text{ kg} \cdot \text{m}^2]$	Mass [kg]
		L			
HC-AQ0135D	10	54		0.0050	0.19
HC-AQ0235D	20	61		0.0072	0.22
HC-AQ0335D	30	68		0.0094	0.25

(Note)[Unit: mm]

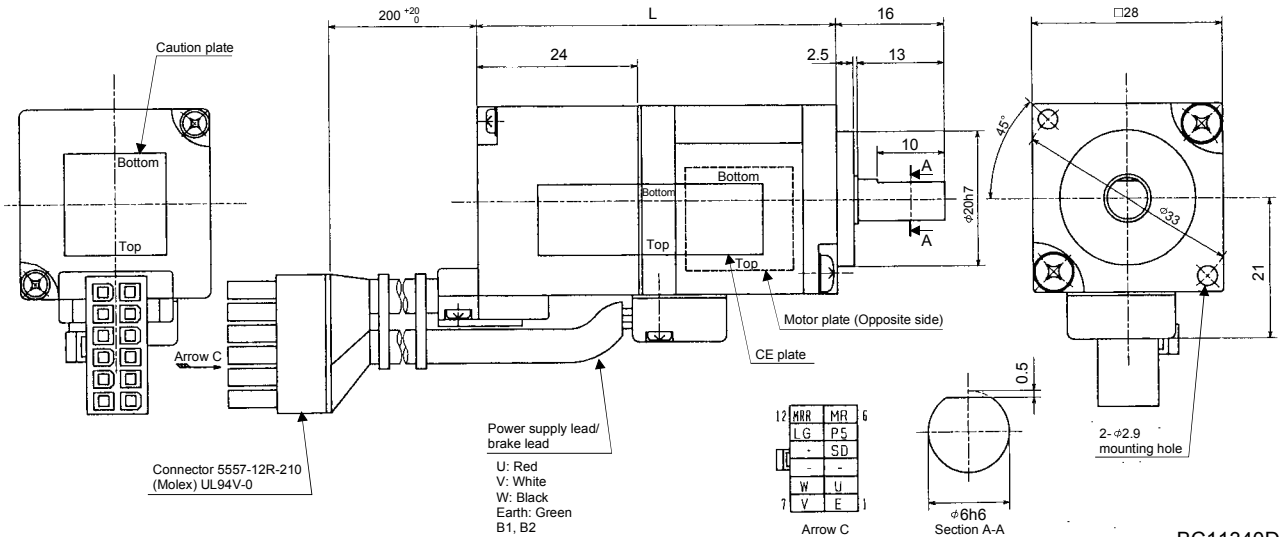

Note: The dimensions without tolerances are reference dimensions.

(2) With electromagnetic brake

Model	Output [W]	Variable Dimensions		Inertia Moment $J[\times 10^{-4} \text{ kg} \cdot \text{m}^2]$	Mass [kg]
		L			
HC-AQ0135BD	10	81		0.0091	0.29
HC-AQ0235BD	20	88		0.0113	0.32
HC-AQ0335BD	30	95		0.0135	0.35

(Note)[Unit: mm]

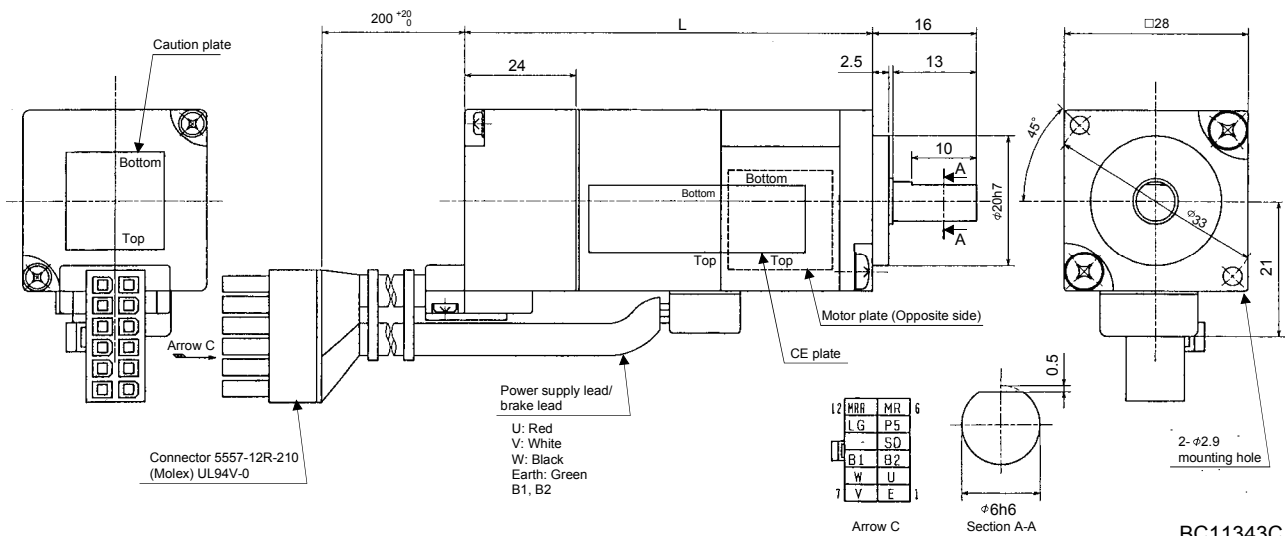

Note: The dimensions without tolerances are reference dimensions.

7. OUTLINE DIMENSION DRAWINGS

7.1.10 HA-LF series

Terminal box detail diagram

Motor Model	HA-LF30K2 HA-LF37K2 HA-LF30K24 HA-LF37K24	HA-LF45K24 HA-LF55K24	
Motor power supply lead size	8mm ² (AWG8) × 2 parallel	22mm ² (AWG4) × 2 parallel	
Motor power supply terminal block screw size	M8	M10	
Terminal box dimensions (mm)	LA	220	266
	LB	210	230

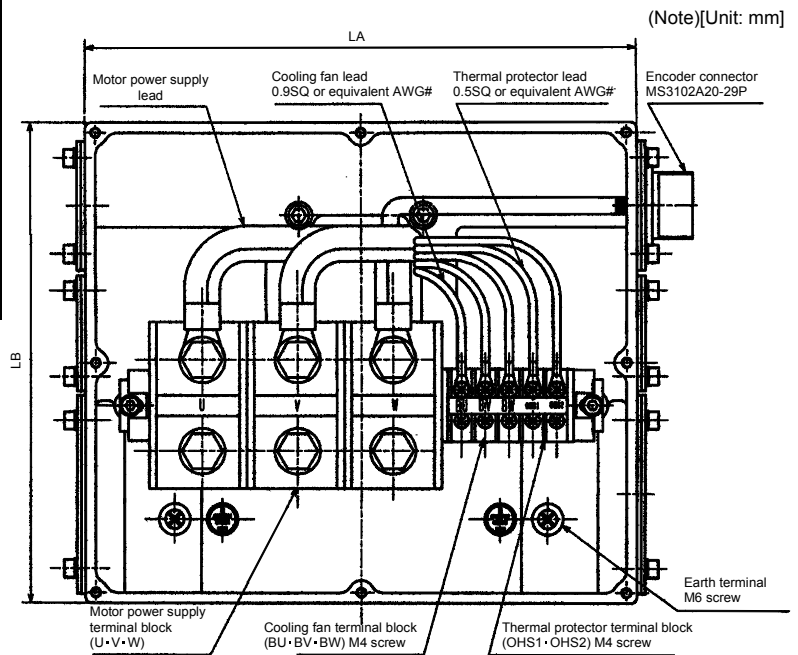

Note: The dimensions without tolerances are reference dimensions.

BG71994C

Model	Output [kW]	Inertia Moment J [$\times 10^{-4} \text{kg} \cdot \text{m}^2$]	Mass [kg]
HA-LF30K24	30	550	160

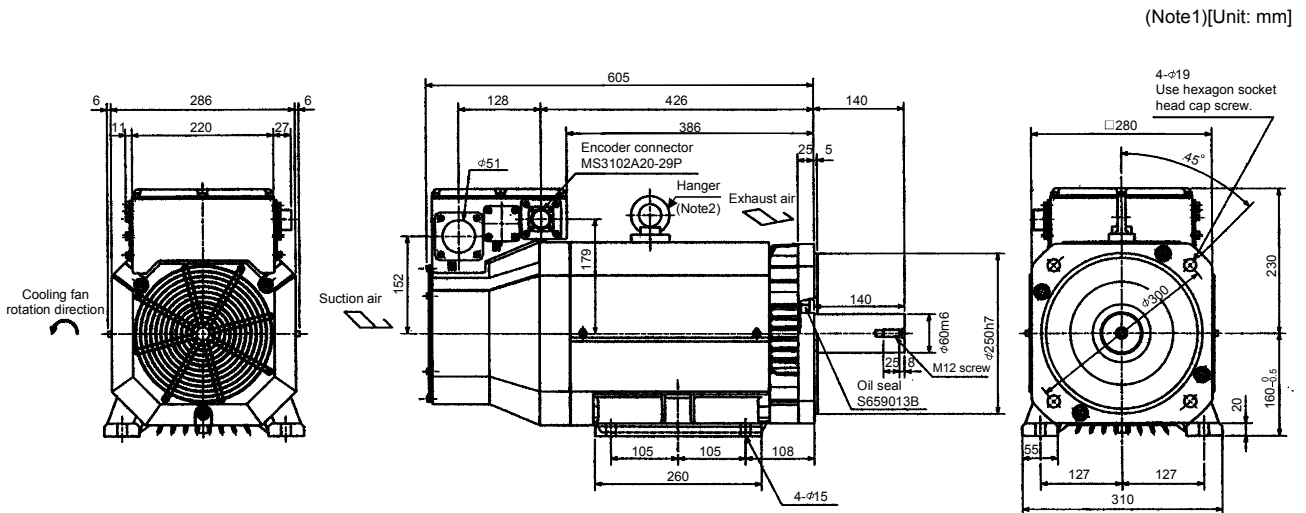

Note: 1. The dimensions without tolerances are reference dimensions.

2. When the motor is used without the hanger, plug the threaded hole with a bolt of M16 \times 20mm or less.

BC10833

7. OUTLINE DIMENSION DRAWINGS

Model	Output [kW]	Inertia Moment $J[\times 10^{-4} \text{ kg} \cdot \text{m}^2]$	Mass [kg]
HA-LF37K24	37	650	180

(Note1)[Unit: mm]

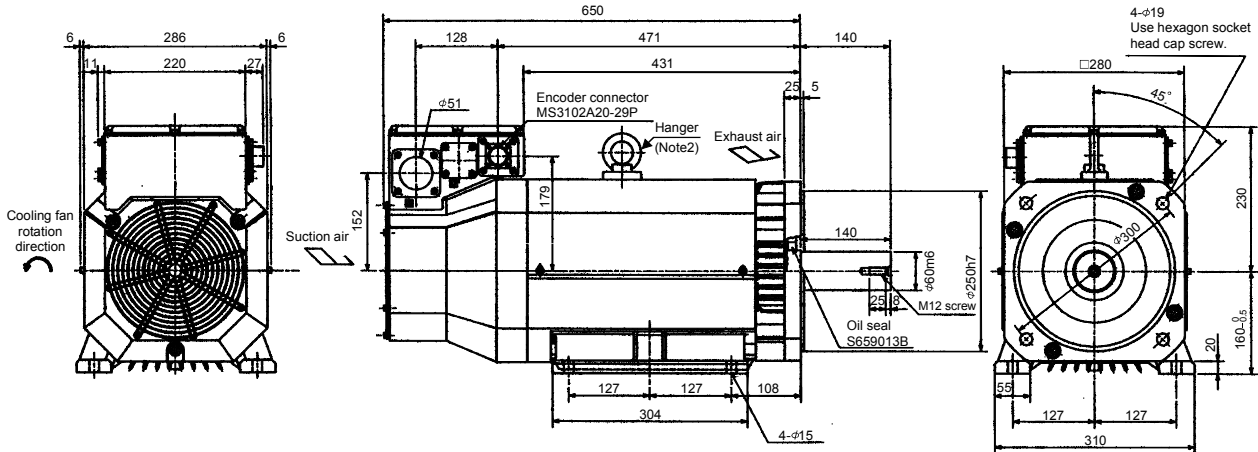

Note: 1. The dimensions without tolerances are reference dimensions.

2. When the motor is used without the hanger, plug the threaded hole with a bolt of M16 × 20mm or less.

BC10788C

Model	Output [kW]	Inertia Moment $J[\times 10^{-4} \text{ kg} \cdot \text{m}^2]$	Mass [kg]
HA-LF45K24	45	1080	230

(Note1)[Unit: mm]

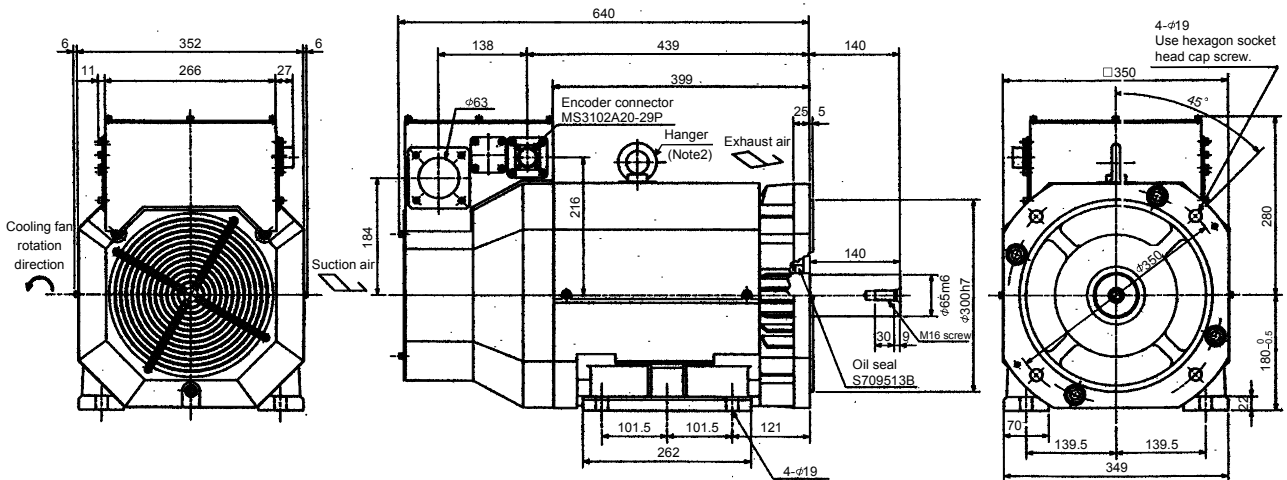

Note:1. The dimensions without tolerances are reference dimensions.

2. When the motor is used without the hanger, plug the threaded hole with a bolt of M16 × 20mm or less.

BC11107A

7. OUTLINE DIMENSION DRAWINGS

Model	Output [kW]	Inertia Moment $J[\times 10^{-4} \text{ kg} \cdot \text{m}^2]$	Mass [kg]
HA-LF55K24	55	1310	250

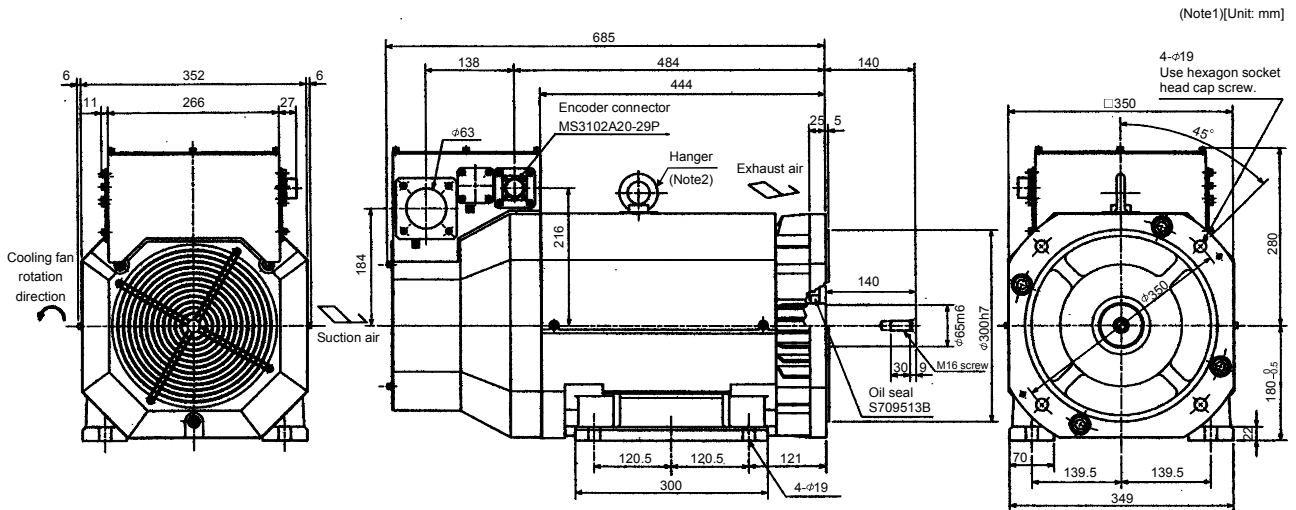

Note: 1. The dimensions without tolerances are reference dimensions.
 2. When the motor is used without the hanger, plug the threaded hole with a bolt of M16×20mm or less.

BC10522F

Model	Output [kW]	Inertia Moment $J[\times 10^{-4} \text{ kg} \cdot \text{m}^2]$	Mass [kg]
HA-LF30K2	30	550	160

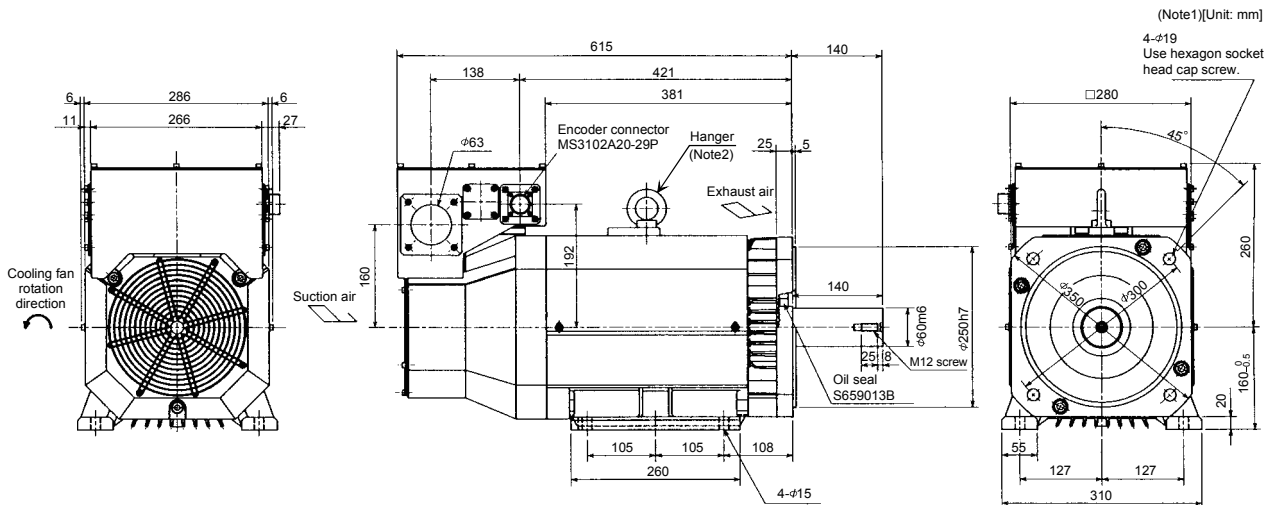

Note: 1. The dimensions without tolerances are reference dimensions.
 2. When the motor is used without the hanger, plug the threaded hole with a bolt of M16×20mm or less.

BC12180*

7. OUTLINE DIMENSION DRAWINGS

Model	Output [kW]	Inertia Moment J [$\times 10^{-4}$ kg \cdot m ²]	Mass [kg]
HA-LF37K2	37	650	180

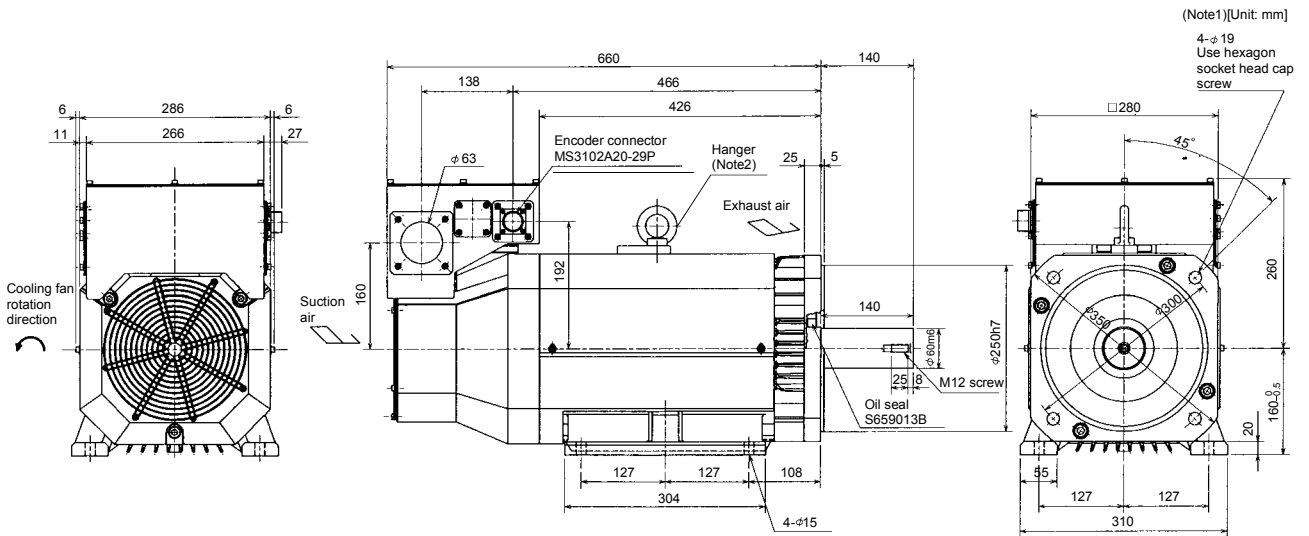

Note: 1. The dimensions without tolerances are reference dimensions.

2. When the motor is used without the hanger, plug the threaded hole with a bolt of M16 \times 20 mm or less.

BC12181*

7. OUTLINE DIMENSION DRAWINGS

7.1.11 HC-MFS • HC-KFS series

(1) Standard (without electromagnetic brake, without reduction gear)

Model	Output [W]	Variable Dimensions		Inertia Moment $J[\times 10^{-4} \text{ kg} \cdot \text{m}^2]$	Mass [kg]
		L	KL		
HC-MFS053	50	81.5	29.5	0.019	0.40
HC-MFS13	100	96.5	44.5	0.03	0.53
HC-KFS053	50	81.5	29.5	0.053	0.40
HC-KFS13	100	96.5	44.5	0.084	0.53

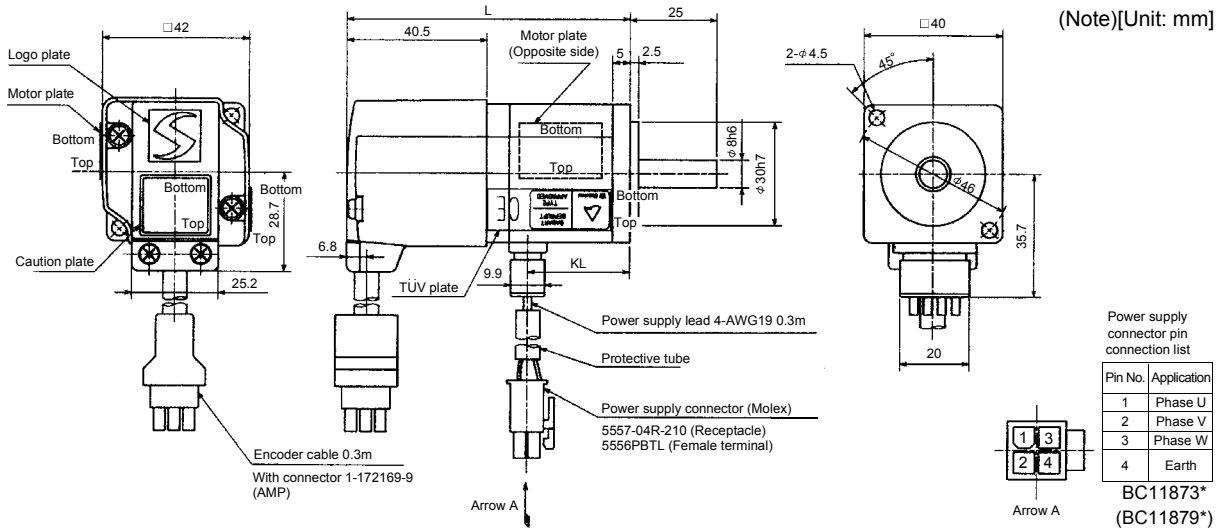

Note: The dimensions without tolerances are reference dimensions.

Model	Output [W]	Variable Dimensions		Inertia Moment $J[\times 10^{-4} \text{ kg} \cdot \text{m}^2]$	Mass [kg]
		L	KL		
HC-MFS23	200	99.5	49.1	0.088	0.99
HC-MFS43	400	124.5	72.1	0.143	1.45
HC-KFS23	200	99.5	49.1	0.42	0.99
HC-KFS43	400	124.5	72.1	0.67	1.45

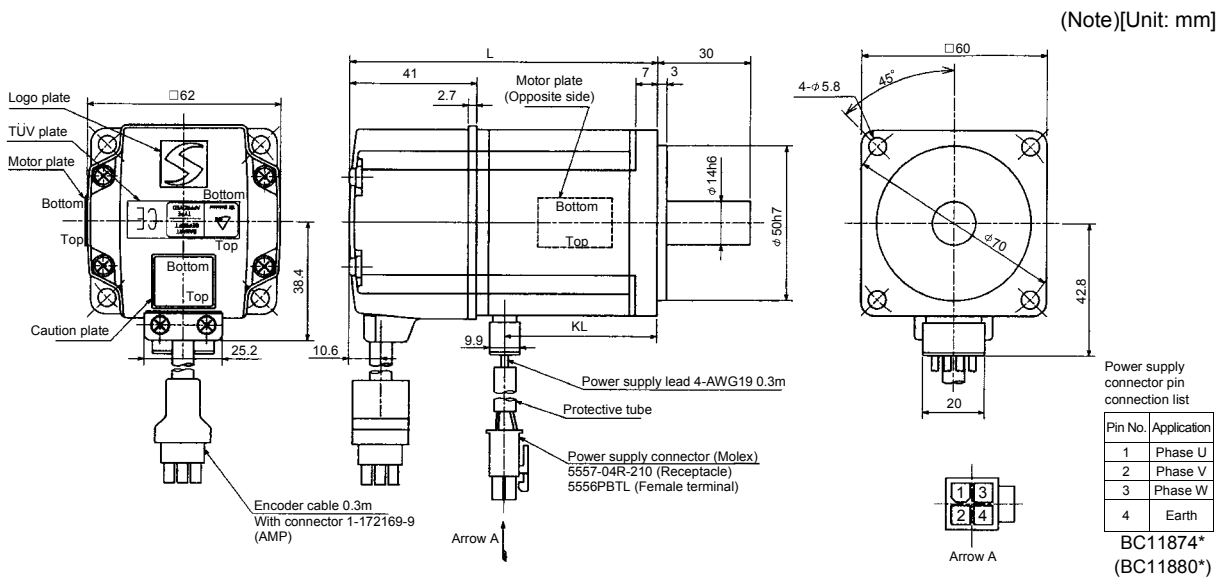

Note: The dimensions without tolerances are reference dimensions.

7. OUTLINE DIMENSION DRAWINGS

Model	Output [W]	Inertia Moment $J[\times 10^{-4} \text{ kg} \cdot \text{m}^2]$	Mass [kg]
HC-MFS73	750	0.6	3
HC-KFS73	750	1.51	3

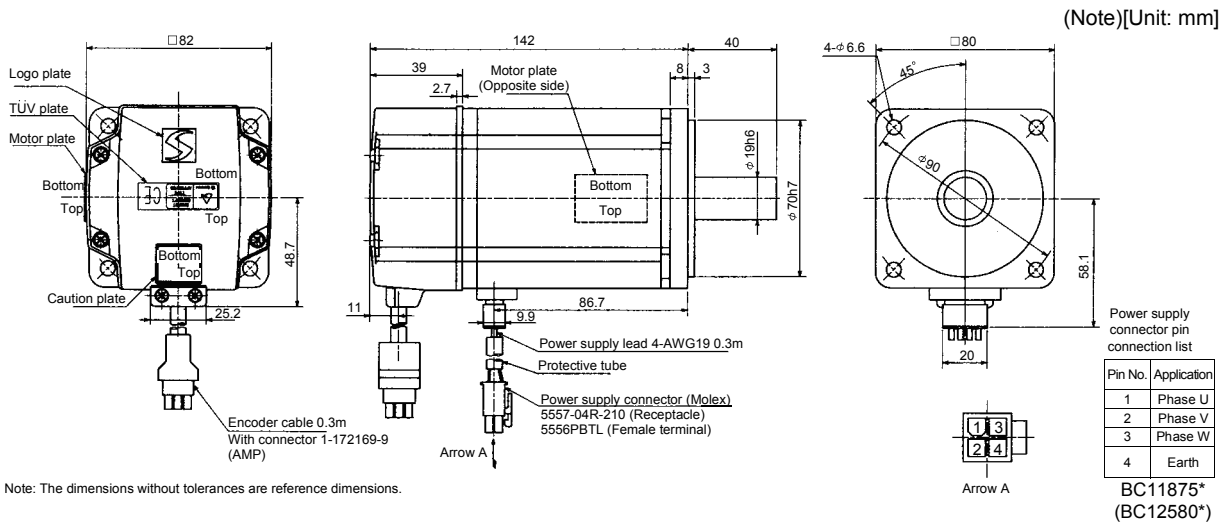

(2) With electromagnetic brake

Model	Output [W]	Variable Dimensions		Brake static friction torque [N · m]	Inertia Moment $J[\times 10^{-4} \text{ kg} \cdot \text{m}^2]$	Mass [kg]
		L	KL			
HC-MFS053B	50	109.5	29.5	0.32	0.022	0.75
HC-MFS13B	100	124.5	44.5	0.32	0.032	0.89
HC-KFS053B	50	109.5	29.5	0.32	0.056	0.75
HC-KFS13B	100	124.5	44.5	0.32	0.087	0.89

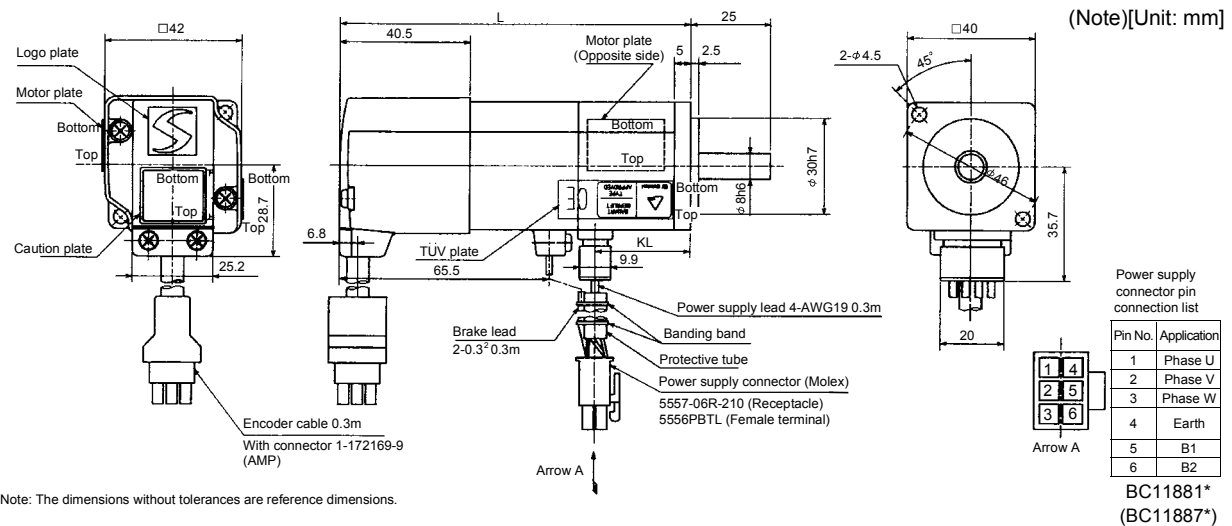

7. OUTLINE DIMENSION DRAWINGS

Model	Output [W]	Variable Dimensions		Brake static friction torque [N · m]	Inertia Moment $J[\times 10^{-4} \text{ kg} \cdot \text{m}^2]$	Mass [kg]
		L	KL			
HC-MFS23B	200	131.5	49.1	1.3	0.136	1.6
HC-MFS43B	400	156.5	72.1	1.3	0.191	2.1
HC-KFS23B	200	131.5	49.1	1.3	0.310	1.6
HC-KFS43B	400	156.5	72.1	1.3	0.510	2.1

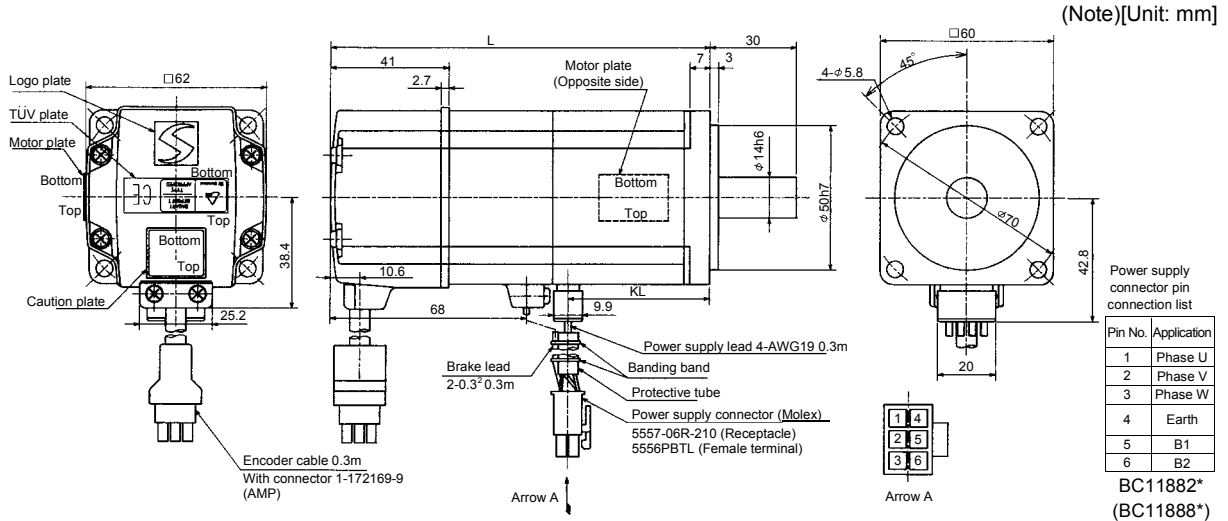

Note: The dimensions without tolerances are reference dimensions.

Model	Output [W]	Brake static friction torque [N · m]	Inertia Moment $J[\times 10^{-4} \text{ kg} \cdot \text{m}^2]$	Mass [kg]
HC-MFS73B	750	2.4	0.725	4.0
HC-KFS73B	750	2.4	1.635	4.0

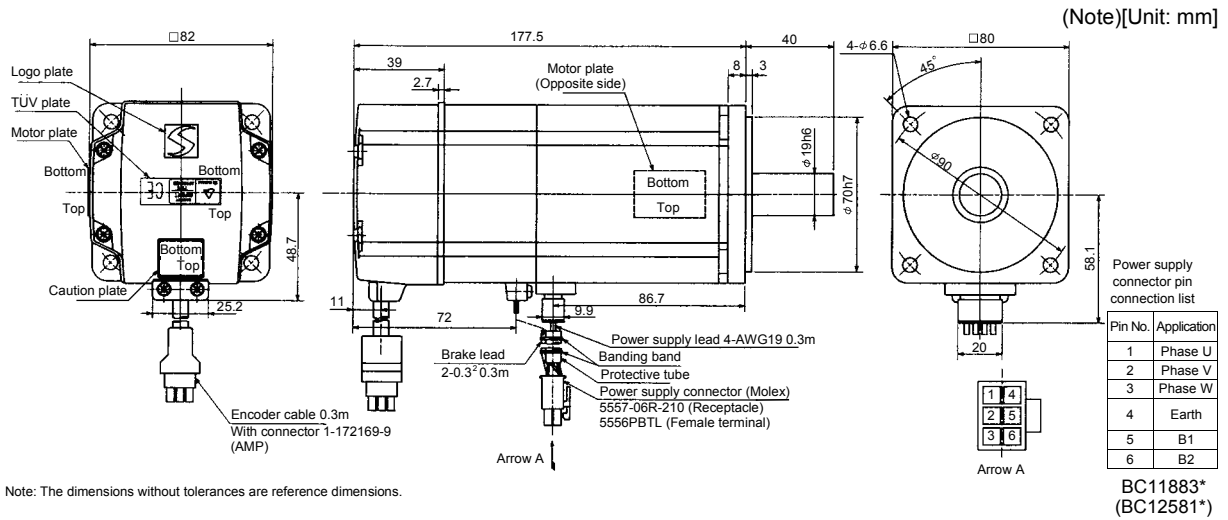

Note: The dimensions without tolerances are reference dimensions.

7. OUTLINE DIMENSION DRAWINGS

(3) With reduction gear for general industrial machine

The outer frame of the reduction gear is a material surface such as casting. Its actual dimensions may be 1 to 3mm larger than the drawing dimensions. Design the machine side with allowances.

(a) Without electromagnetic brake

Model	Output [W]	Variable Dimensions		Reduction Gear Model	Reduction Ratio (Actual Reduction Ratio)	Inertia Moment $J[\times 10^{-4} \text{ kg} \cdot \text{m}^2]$	Backlash	Mass [kg]
		L	KL					
HC-MFS053G1	50	126	74	K6505	1/5(9/44)	0.055	60min. max.	1.4
HC-MFS053G1	50	144	92	K6512	1/12(49/576)	0.077	60min. max.	1.8
HC-MFS053G1	50	144	92	K6520	1/20(25/484)	0.059	60min. max.	1.8
HC-KFS053G1	50	126	74	K6505	1/5(9/44)	0.090	60min. max.	1.4
HC-KFS053G1	50	144	92	K6512	1/12(49/576)	0.112	60min. max.	1.8
HC-KFS053G1	50	144	92	K6520	1/20(25/484)	0.094	60min. max.	1.8

(Note)[Unit: mm]

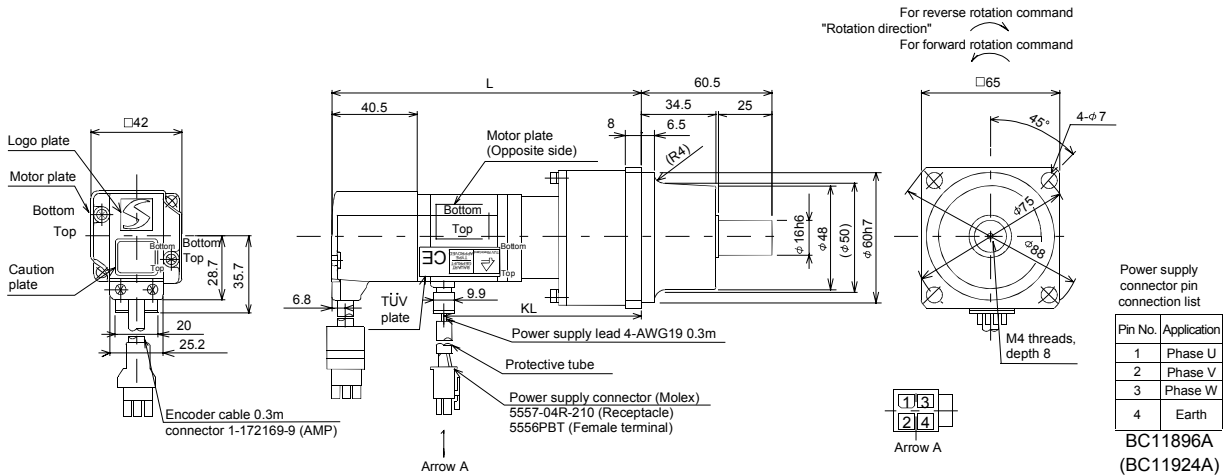

Note: The dimensions without tolerances are reference dimensions.

Model	Output [W]	Variable Dimensions		Reduction Gear Model	Reduction Ratio (Actual Reduction Ratio)	Inertia Moment $J[\times 10^{-4} \text{ kg} \cdot \text{m}^2]$	Backlash	Mass [kg]
		L	KL					
HC-MFS13G1	100	141	89	K6505	1/5(9/44)	0.067	60min. max.	1.5
HC-MFS13G1	100	159	107	K6512	1/12(49/576)	0.089	60min. max.	1.9
HC-MFS13G1	100	159	107	K6520	1/20(25/484)	0.071	60min. max.	1.9
HC-KFS13G1	100	141	89	K6505	1/5(9/44)	0.121	60min. max.	1.5
HC-KFS13G1	100	159	107	K6512	1/12(49/576)	0.143	60min. max.	1.9
HC-KFS13G1	100	159	107	K6520	1/20(25/484)	0.125	60min. max.	1.9

(Note)[Unit: mm]

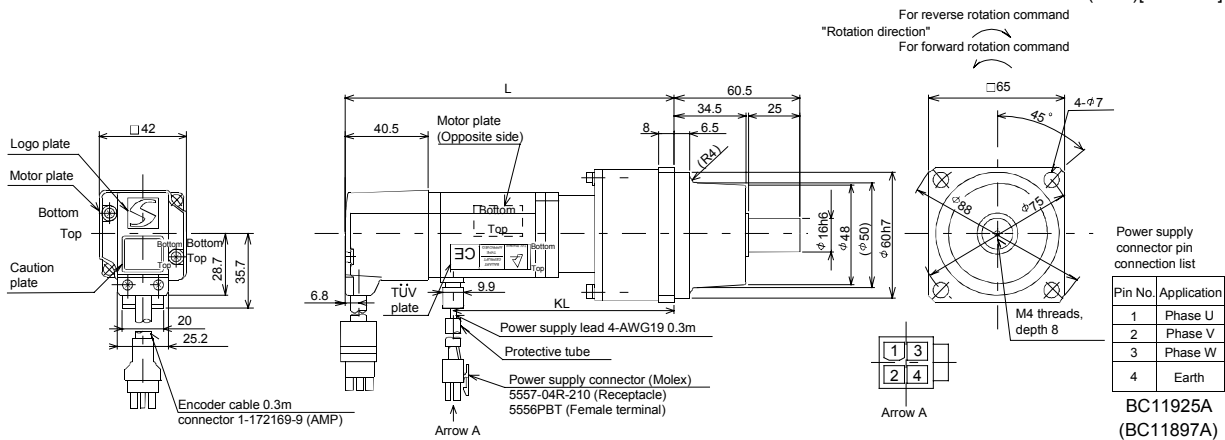

Note: The dimensions without tolerances are reference dimensions.

7. OUTLINE DIMENSION DRAWINGS

Model	Output [W]	Variable Dimensions		Reduction Gear Model	Reduction Ratio (Actual Reduction Ratio)	Inertia Moment J [$\times 10^{-4} \text{ kg} \cdot \text{m}^2$]	Mass [kg]
		L	KL				
HC-MFS23G1	200	153	102.6	K9005	1/5(19/96)	0.249	3.3
HC-MFS23G1	200	173	122.6	K9012	1/12(25/288)	0.293	3.9
HC-MFS23G1	200	173	122.6	K9020	1/20(253/5000)	0.266	3.9
HC-KFS23G1	200	153	102.6	K9005	1/5(19/96)	0.420	3.3
HC-KFS23G1	200	173	122.6	K9012	1/12(25/288)	0.470	3.9
HC-KFS23G1	200	173	122.6	K9020	1/20(253/5000)	0.440	3.9

(Note)[Unit: mm]

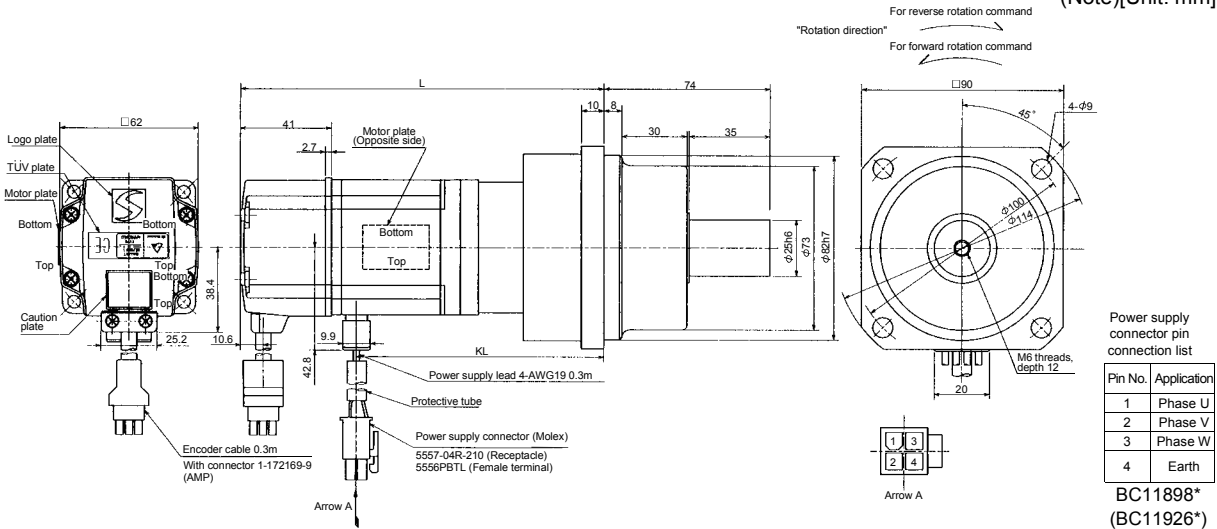

Note: The dimensions without tolerances are reference dimensions.

Model	Output [W]	Variable Dimensions		Reduction Gear Model	Reduction Ratio (Actual Reduction Ratio)	Inertia Moment J [$\times 10^{-4} \text{ kg} \cdot \text{m}^2$]	Mass [kg]
		L	KL				
HC-MFS43G1	400	178	125.6	K9005	1/5(19/96)	0.296	3.8
HC-MFS43G1	400	198	145.6	K9012	1/12(25/288)	0.339	4.4
HC-KFS43G1	400	178	125.6	K9005	1/5(19/96)	0.610	3.8
HC-KFS43G1	400	198	145.6	K9012	1/12(25/288)	0.660	4.4

(Note)[Unit: mm]

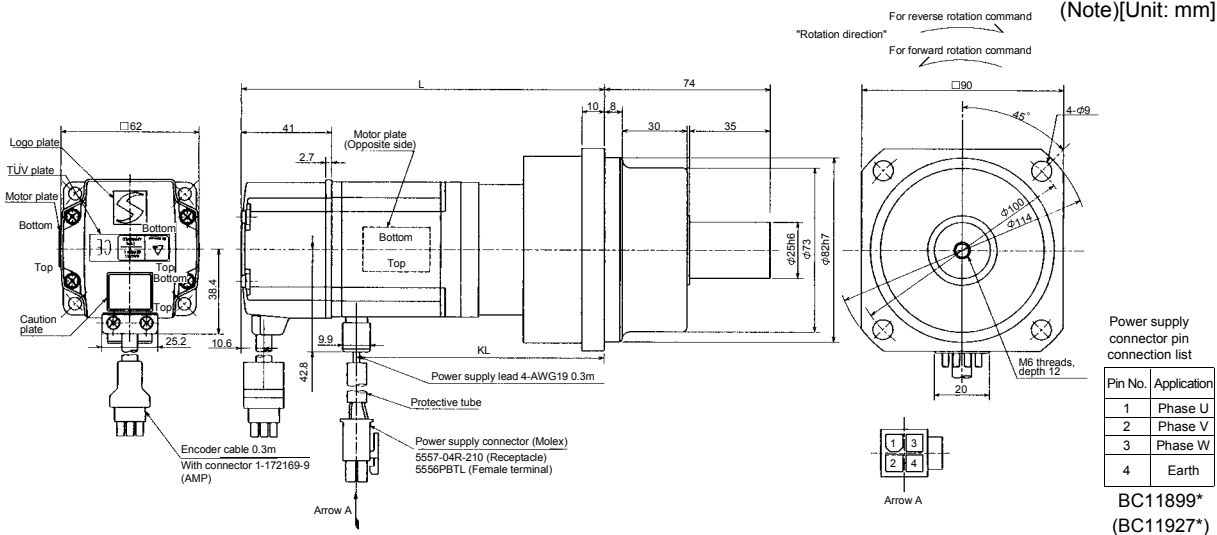

Note: The dimensions without tolerances are reference dimensions.

7. OUTLINE DIMENSION DRAWINGS

Model	Output [W]	Reduction Gear Model	Reduction Ratio		Inertia Moment J [$\times 10^{-4}$ kg · m ²]	Backlash	Mass [kg]
			Normal Reduction ratio	Actual Reduction Ratio			
HC-MFS43G1	400	K10020	1/20	253/5000	0.653	60min. max.	5.5
HC-MFS73G1	750	K10005	1/5	1/5	1.02	60min. max.	6.2
HC-MFS73G1	750	K10012	1/12	525/6048	1.686	60min. max.	7.3
HC-MFS73G1	750	K12020	1/20	625/12544	1.75	60min. max.	10.1

Model	Output [W]	Variable Dimensions																						
		D	LH	LK	LT	H	LA	LB	LC	LD	LE	LF	LG	LM	LN	LP	L	LR	KL	LZ	Q	S	P	R
HC-MFS43G1	400	62	38.4	41	10.6	42.8	115	95	132	100	10	73	10	13	16	86	201.5	90	149.1	9	50	32	M8	16
HC-MFS73G1	750	82	48.7	39	11	58.1	115	95	132	100	10	73	10	13	16	86	207	90	151.7	9	50	32	M8	16
HC-MFS73G1	750	82	48.7	39	11	58.1	115	95	132	100	10	73	10	13	16	86	229	90	173.7	9	50	32	M8	16
HC-MFS73G1	750	82	48.7	39	11	58.1	140	115	162	120	12	90	15	13	20	104	242	106	186.7	14	60	40	M10	20

Model	Output [W]	Reduction Gear Model	Reduction Ratio		Inertia Moment J [$\times 10^{-4}$ kg · m ²]	Backlash	Mass [kg]
			Normal Reduction ratio	Actual Reduction Ratio			
HC-KFS43G1	400	K10020	1/20	253/5000	0.970	60min. max.	5.5
HC-KFS73G1	750	K10005	1/5	1/5	1.930	60min. max.	6.2
HC-KFS73G1	750	K10012	1/12	525/6048	2.596	60min. max.	7.3
HC-KFS73G1	750	K12020	1/20	625/12544	2.660	60min. max.	10.1

Model	Output [W]	Variable Dimensions																						
		D	LH	LK	LT	H	LA	LB	LC	LD	LE	LF	LG	LM	LN	LP	L	LR	KL	LZ	Q	S	P	R
HC-KFS43G1	400	62	38.4	41	10.6	42.8	115	95	132	100	10	73	10	13	16	86	201.5	90	149.1	9	50	32	M8	16
HC-KFS73G1	750	82	48.7	39	11	58.1	115	95	132	100	10	73	10	13	16	86	207	90	151.7	9	50	32	M8	16
HC-KFS73G1	750	82	48.7	39	11	58.1	115	95	132	100	10	73	10	13	16	86	229	90	173.7	9	50	32	M8	16
HC-KFS73G1	750	82	48.7	39	11	58.1	140	115	162	120	12	90	15	13	20	104	242	106	186.7	14	60	40	M10	20

(Note)[Unit: mm]

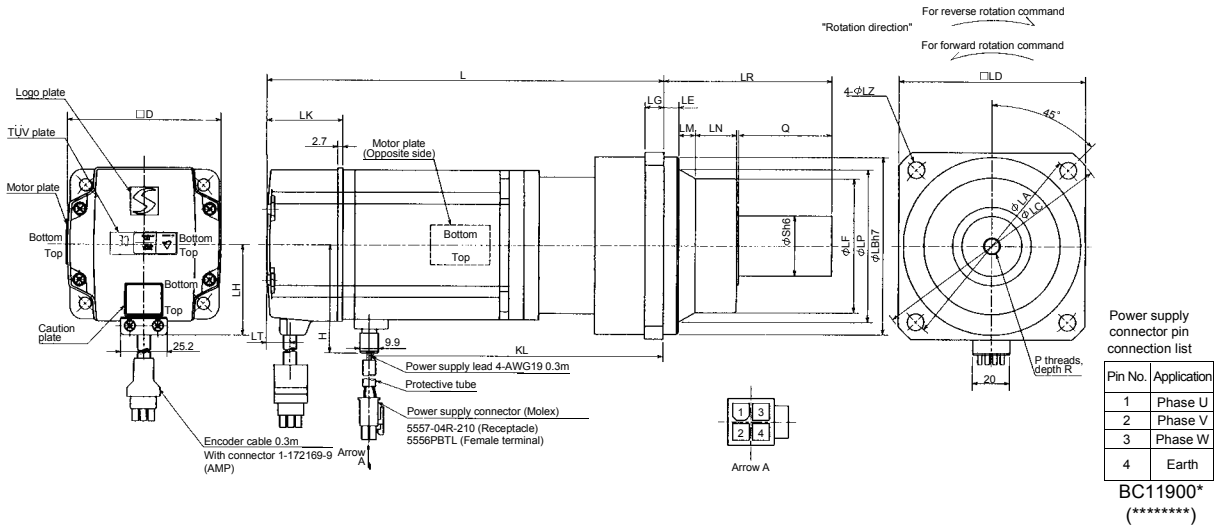

Note: The dimensions without tolerances are reference dimensions.

7. OUTLINE DIMENSION DRAWINGS

(b) With electromagnetic brake

Model	Output [W]	Variable Dimensions		Brake static friction torque [N · m]	Reduction Gear Model	Reduction Ratio (Actual Reduction Ratio)	Inertia Moment $J[\times 10^{-4} \text{ kg} \cdot \text{m}^2]$	Backlash	Mass [kg]
		L	KL						
HC-MFS053BG1	50	154	74	0.32	K6505	1/5(9/44)	0.058	60min. max.	1.8
HC-MFS053BG1	50	172	92	0.32	K6512	1/12(49/576)	0.080	60min. max.	2.2
HC-MFS053BG1	50	172	92	0.32	K6520	1/20(25/484)	0.062	60min. max.	2.2
HC-KFS053BG1	50	154	74	0.32	K6505	1/5(9/44)	0.093	60min. max.	1.8
HC-KFS053BG1	50	172	92	0.32	K6512	1/12(49/576)	0.115	60min. max.	2.2
HC-KFS053BG1	50	172	92	0.32	K6520	1/20(25/484)	0.097	60min. max.	2.2

(Note)[Unit: mm]

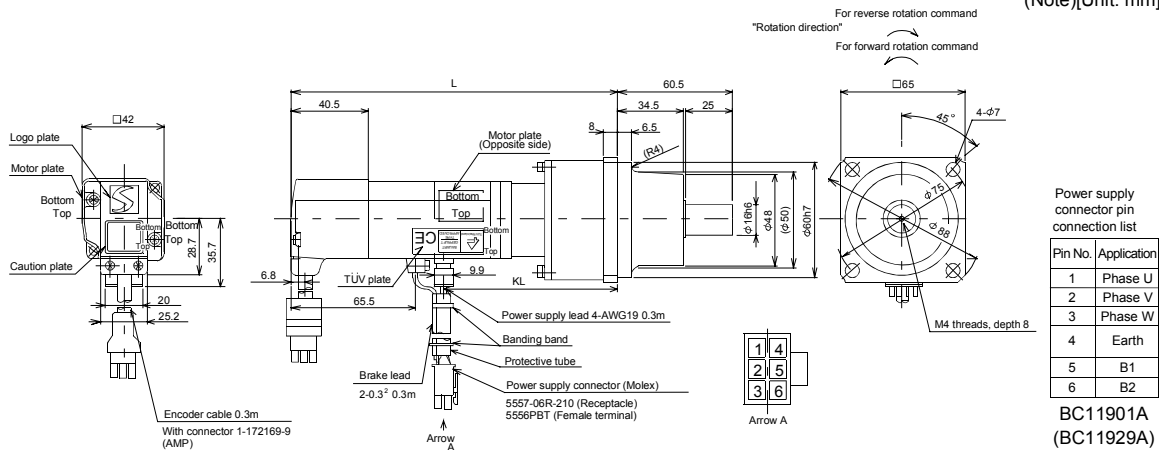

Note: The dimensions without tolerances are reference dimensions.

Model	Output [W]	Variable Dimensions		Brake static friction torque [N · m]	Reduction Gear Model	Reduction Ratio (Actual Reduction Ratio)	Inertia Moment $J[\times 10^{-4} \text{ kg} \cdot \text{m}^2]$	Backlash	Mass [kg]
		L	KL						
HC-MFS13BG1	100	169	89	0.32	K6505	1/5(9/44)	0.069	60min. max.	1.9
HC-MFS13BG1	100	187	107	0.32	K6512	1/12(49/576)	0.091	60min. max.	2.3
HC-MFS13BG1	100	187	107	0.32	K6520	1/20(25/484)	0.073	60min. max.	2.3
HC-KFS13BG1	100	169	89	0.32	K6505	1/5(9/44)	0.124	60min. max.	1.9
HC-KFS13BG1	100	187	107	0.32	K6512	1/12(49/576)	0.146	60min. max.	2.3
HC-KFS13BG1	100	187	107	0.32	K6520	1/20(25/484)	0.128	60min. max.	2.3

(Note)[Unit: mm]

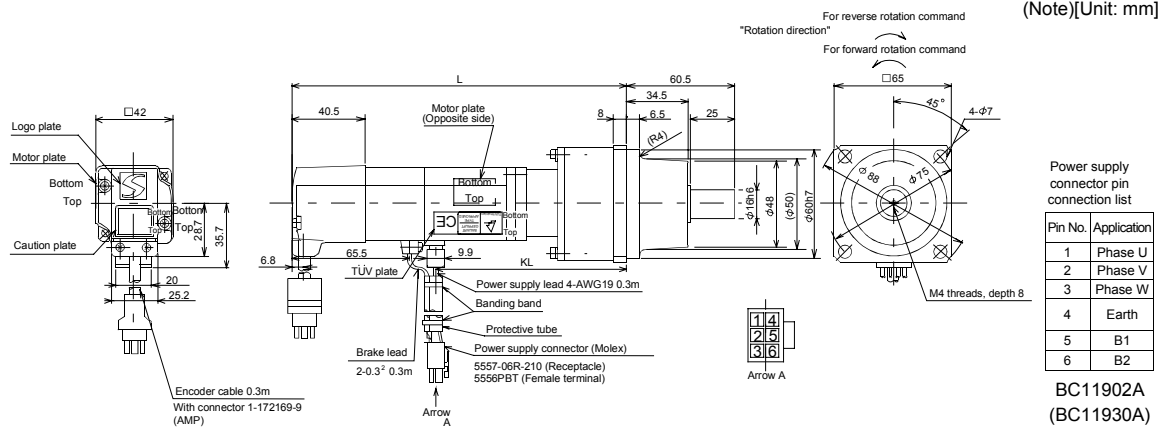

Note: The dimensions without tolerances are reference dimensions.

7. OUTLINE DIMENSION DRAWINGS

Model	Output [W]	Variable Dimensions		Reduction Gear Model	Reduction Ratio (Actual Reduction Ratio)	Inertia Moment $J[\times 10^{-4} \text{kg} \cdot \text{m}^2]$	Mass [kg]	Brake static friction torque [N · m]
		L	KL					
HC-MFS23BG1	200	185	102.6	K9005	1/5(19/96)	0.289	3.9	1.3
HC-MFS23BG1	200	205	122.6	K9012	1/12(25/288)	0.333	4.5	1.3
HC-MFS23BG1	200	205	122.6	K9020	1/20(253/5000)	0.306	4.5	1.3
HC-KFS23BG1	200	185	102.6	K9005	1/5(19/96)	0.470	3.9	1.3
HC-KFS23BG1	200	205	122.6	K9012	1/12(25/288)	0.520	4.5	1.3
HC-KFS23BG1	200	205	122.6	K9020	1/20(253/5000)	0.490	4.5	1.3

(Note)[Unit: mm]

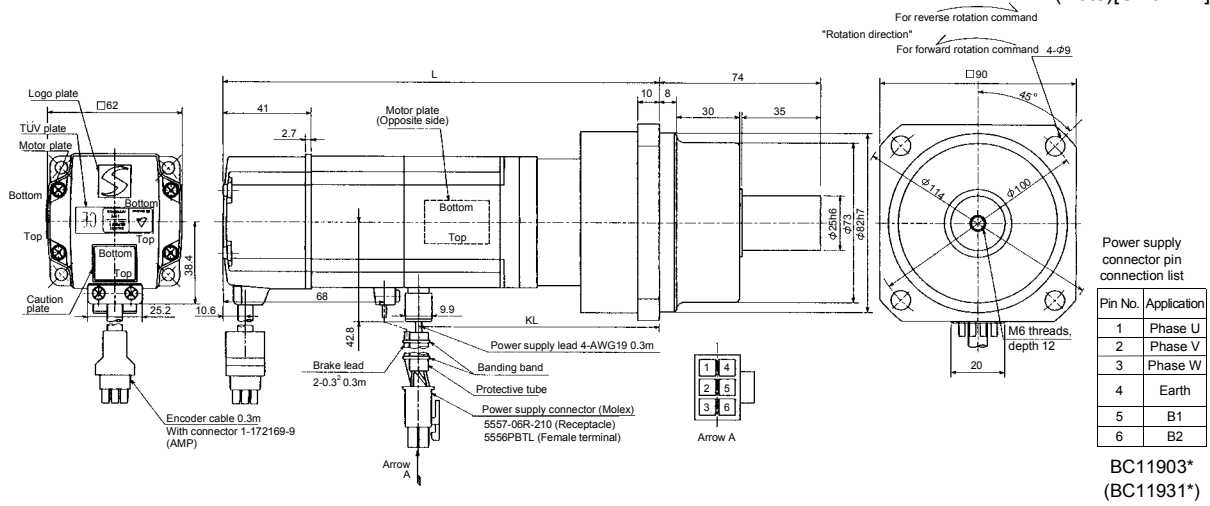

Note: The dimensions without tolerances are reference dimensions.

Model	Output [W]	Variable Dimensions		Reduction Gear Model	Reduction Ratio (Actual Reduction Ratio)	Inertia Moment $J[\times 10^{-4} \text{kg} \cdot \text{m}^2]$	Mass [kg]	Brake static friction torque [N · m]
		L	KL					
HC-MFS43BG1	400	210	125.6	K9005	1/5(19/96)	0.344	4.4	1.3
HC-MFS43BG1	400	230	145.6	K9012	1/12(25/288)	0.388	5.0	1.3
HC-KFS43BG1	400	210	125.6	K9005	1/5(19/96)	0.660	4.4	1.3
HC-KFS43BG1	400	230	145.6	K9012	1/12(25/288)	0.710	5.0	1.3

(Note)[Unit: mm]

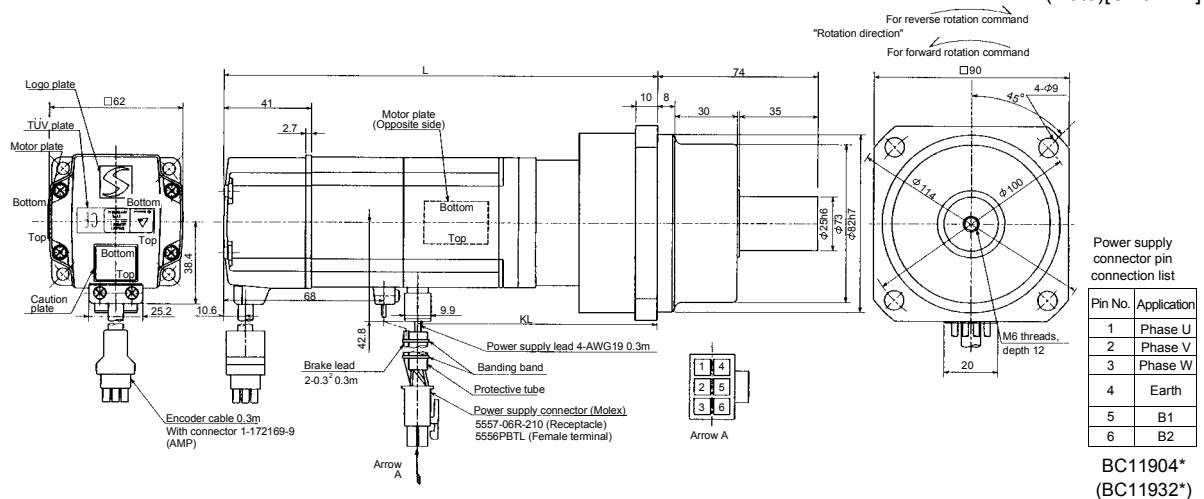

Note: The dimensions without tolerances are reference dimensions.

7. OUTLINE DIMENSION DRAWINGS

Model	Output [W]	Brake static friction torque [N · m]	Reduction Gear Model	Reduction Ratio		Inertia Moment J[×10 ⁻⁴ kg · m ²]	Backlash	Mass [kg]
				Normal Reduction ratio	Actual Reduction Ratio			
HC-MFS43BG1	400	1.3	K10020	1/20	253/5000	0.700	60min. max.	6.1
HC-MFS73BG1	750	2.4	K10005	1/5	1/5	1.145	60min. max.	7.2
HC-MFS73BG1	750	2.4	K10012	1/12	525/6048	1.811	60min. max.	8.3
HC-MFS73BG1	750	2.4	K12020	1/20	625/12544	1.875	60min. max.	11.1

Model	Output [W]	Variable Dimensions																							
		D	LH	LK	LT	LX	H	LA	LB	LC	LD	LE	LF	LG	LM	LN	LP	L	LR	KL	LZ	Q	S	P	R
HC-MFS43BG1	400	62	38.4	41	10.6	68	42.8	115	95	132	100	10	73	10	13	16	86	233.5	90	149.1	9	50	32	M8	16
HC-MFS73BG1	750	82	48.7	39	11	72	58.1	115	95	132	100	10	73	10	13	16	86	242.5	90	151.7	9	50	32	M8	16
HC-MFS73BG1	750	82	48.7	39	11	72	58.1	115	95	132	100	10	73	10	13	16	86	264.5	90	173.7	9	50	32	M8	16
HC-MFS73BG1	750	82	48.7	39	11	72	58.1	140	115	162	120	12	90	15	13	20	104	277.5	106	186.7	14	60	40	M10	20

Model	Output [W]	Brake static friction torque [N · m]	Reduction Gear Model	Reduction Ratio		Inertia Moment J[×10 ⁻⁴ kg · m ²]	Backlash	Mass [kg]
				Normal Reduction ratio	Actual Reduction Ratio			
HC-KFS43BG1	400	1.3	K10020	1/20	253/5000	1.02	60min. max.	6.1
HC-KFS73BG1	750	2.4	K10005	1/5	1/5	2.055	60min. max.	7.2
HC-KFS73BG1	750	2.4	K10012	1/12	525/6048	2.721	60min. max.	8.3
HC-KFS73BG1	750	2.4	K12020	1/20	625/12544	2.785	60min. max.	11.1

Model	Output [W]	Variable Dimensions																							
		D	LH	LK	LT	LX	H	LA	LB	LC	LD	LE	LF	LG	LM	LN	LP	L	LR	KL	LZ	Q	S	P	R
HC-KFS43BG1	400	62	38.4	41	10.6	68	42.8	115	95	132	100	10	73	10	13	16	86	233.5	90	149.1	9	50	32	M8	16
HC-KFS73BG1	750	82	48.7	39	11	72	58.1	115	95	132	100	10	73	10	13	16	86	242.5	90	151.7	9	50	32	M8	16
HC-KFS73BG1	750	82	48.7	39	11	72	58.1	115	95	132	100	10	73	10	13	16	86	264.5	90	173.7	9	50	32	M8	16
HC-KFS73BG1	750	82	48.7	39	11	72	58.1	140	115	162	120	12	90	15	13	20	104	277.5	106	186.7	14	60	40	M10	20

(Note)[Unit: mm]

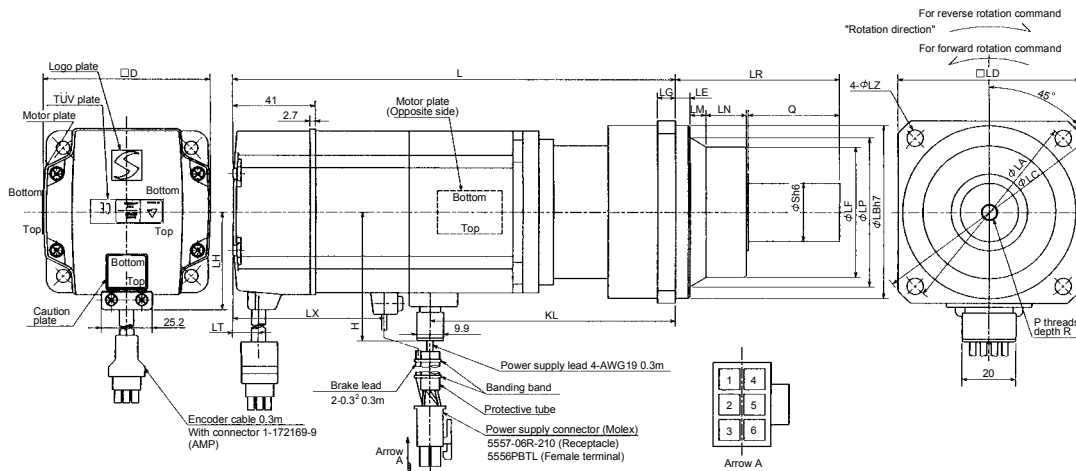

Power supply connector pin connection list

Pin No.	Application
1	Phase U
2	Phase V
3	Phase W
4	Earth
5	B1
6	B2

Note: The dimensions without tolerances are reference dimensions.

BC11905*
(*****)

7. OUTLINE DIMENSION DRAWINGS

(4) With reduction gear for precision application

The outer frame of the reduction gear is a material surface such as casting. Its actual dimensions may be 1 to 3mm larger than the drawing dimensions. Design the machine side with allowances.

(a) Without electromagnetic brake

Model	Output [W]	Variable Dimensions		Reduction Gear Model	Reduction Ratio	Inertia Moment $J[\times 10^{-4} \text{kg} \cdot \text{m}^2]$	Backlash	Mass [kg]
		L	KL					
HC-MFS053G2	50	130	78	BK1-05B-A5MEKA	1/5	0.067	3 min. max.	1.4
HC-MFS053G2	50	146	94	BK1-09B-A5MEKA	1/9	0.060	3 min. max.	1.7
HC-MFS053G2	50	146	94	BK1-20B-A5MEKA	1/20	0.069	3 min. max.	1.8
HC-MFS053G2	50	146	94	BK1-29B-A5MEKA	1/29	0.057	3 min. max.	1.8
HC-KFS053G2	50	130	78	BK1-05B-A5MEKA	1/5	0.101	3 min. max.	1.4
HC-KFS053G2	50	146	94	BK1-09B-A5MEKA	1/9	0.095	3 min. max.	1.7
HC-KFS053G2	50	146	94	BK1-20B-A5MEKA	1/20	0.104	3 min. max.	1.8
HC-KFS053G2	50	146	94	BK1-29B-A5MEKA	1/29	0.092	3 min. max.	1.8

(Note)[Unit: mm]

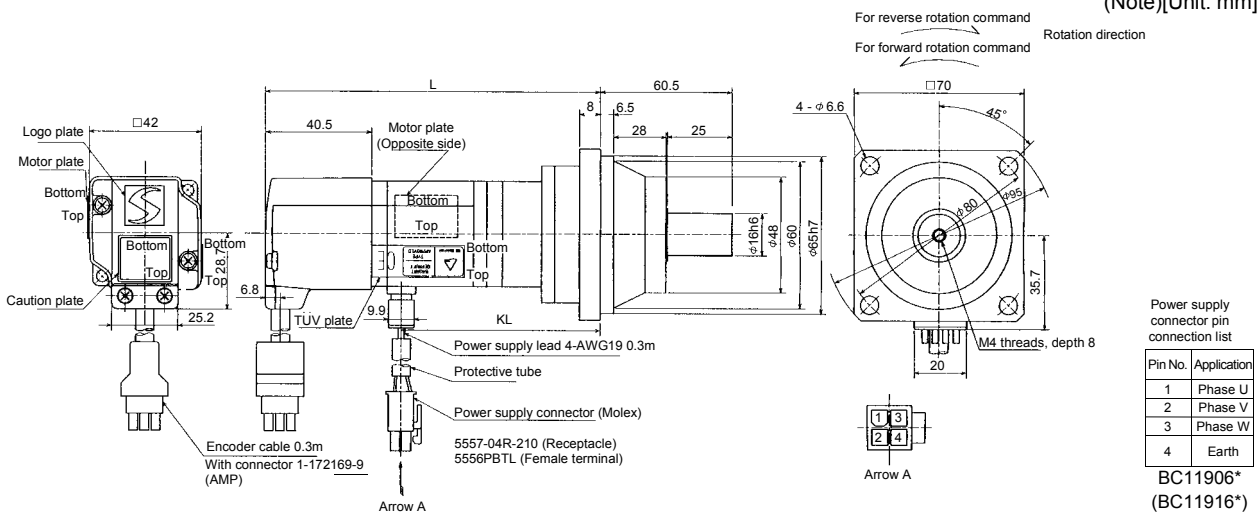

Note: The dimensions without tolerances are reference dimensions.

7. OUTLINE DIMENSION DRAWINGS

Model	Output [W]	Reduction Gear Model	Reduction Ratio	Inertia Moment $J[\times 10^{-4} \text{kg} \cdot \text{m}^2]$	Backlash	Mass [kg]
HC-MFS13G2	100	BK1-05B-01MEKA	1/5	0.078	3 min. max.	1.5
HC-MFS13G2	100	BK1-09B-01MEKA	1/9	0.072	3 min. max.	1.8
HC-MFS13G2	100	BK2-20B-01MEKA	1/20	0.122	3 min. max.	3.0
HC-MFS13G2	100	BK2-29B-01MEKA	1/29	0.096	3 min. max.	3.0

Model	Output [W]	Variable Dimensions																
		LA	LB	LC	LD	LE	LF	LG	LH	LK	L	LR	KL	LZ	Q	S	P	R
HC-MFS13G2	100	80	65	95	70	6	48	8	60	23	145	55	93	6.6	25	16	M4	8
HC-MFS13G2	100	80	65	95	70	6	48	8	60	23	161	55	109	6.6	25	16	M4	8
HC-MFS13G2	100	100	80	115	85	6	65	10	74	33	167	75	115	6.6	35	20	M5	10
HC-MFS13G2	100	100	80	115	85	6	65	10	74	33	167	75	115	6.6	35	20	M5	10

Model	Output [W]	Reduction Gear Model	Reduction Ratio	Inertia Moment $J[\times 10^{-4} \text{kg} \cdot \text{m}^2]$	Backlash	Mass [kg]
HC-KFS13G2	100	BK1-05B-01MEKA	1/5	0.132	3 min. max.	1.5
HC-KFS13G2	100	BK1-09B-01MEKA	1/9	0.126	3 min. max.	1.8
HC-KFS13G2	100	BK2-20B-01MEKA	1/20	0.176	3 min. max.	3.0
HC-KFS13G2	100	BK2-29B-01MEKA	1/29	0.150	3 min. max.	3.0

Model	Output [W]	Variable Dimensions																
		LA	LB	LC	LD	LE	LF	LG	LH	LK	L	LR	KL	LZ	Q	S	P	R
HC-KFS13G2	100	80	65	95	70	6	48	8	60	23	145	55	93	6.6	25	16	M4	8
HC-KFS13G2	100	80	65	95	70	6	48	8	60	23	161	55	109	6.6	25	16	M4	8
HC-KFS13G2	100	100	80	115	85	6	65	10	74	33	167	75	115	6.6	35	20	M5	10
HC-KFS13G2	100	100	80	115	85	6	65	10	74	33	167	75	115	6.6	35	20	M5	10

(Note)[Unit: mm]

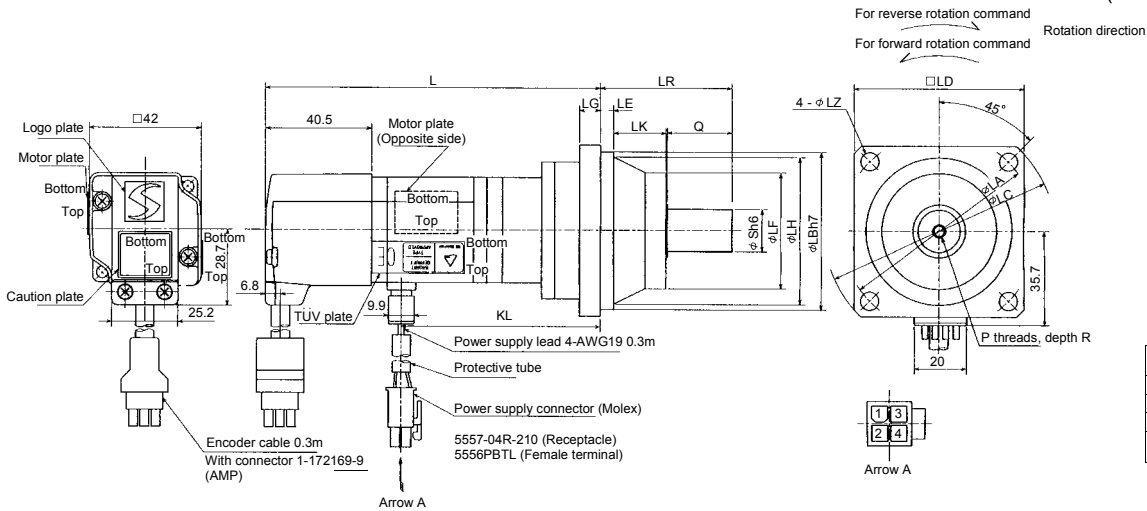

Power supply connector pin connection list

Pin No.	Application
1	Phase U
2	Phase V
3	Phase W
4	Earth

BC11907*
(BC11917*)

Note: The dimensions without tolerances are reference dimensions.

7. OUTLINE DIMENSION DRAWINGS

Model	Output [W]	Reduction Gear Model	Reduction Ratio	Inertia Moment J[$\times 10^{-4}$ kg \cdot m ²]	Mass [kg]
HC-MFS23G2	200	BK1-05B-02MEKA	1/5	0.191	2.1
HC-MFS23G2	200	BK2-09B-02MEKA	1/9	0.208	3.5
HC-MFS23G2	200	BK3-20B-02MEKA	1/20	0.357	5.0
HC-MFS23G2	200	BK3-29B-02MEKA	1/29	0.276	5.0

Model	Output [W]	Variable Dimensions																
		LA	LB	LC	LD	LE	LF	LG	LH	LK	L	LR	KL	LZ	Q	S	P	R
HC-MFS23G2	200	80	65	95	70	6	48	8	60	23	157	55	106.6	6.6	25	16	M4	8
HC-MFS23G2	200	100	80	115	85	6	65	10	74	33	175	75	124.6	6.6	35	20	M5	10
HC-MFS23G2	200	115	95	135	100	8	75	10	85	35	180	85	129.6	9	40	25	M6	12
HC-MFS23G2	200	115	95	135	100	8	75	10	85	35	180	85	129.6	9	40	25	M6	12

Model	Output [W]	Reduction Gear Model	Reduction Ratio	Inertia Moment J[$\times 10^{-4}$ kg \cdot m ²]	Mass [kg]
HC-KFS23G2	200	BK1-05B-02MEKA	1/5	0.360	2.1
HC-KFS23G2	200	BK2-09B-02MEKA	1/9	0.380	3.5
HC-KFS23G2	200	BK3-20B-02MEKA	1/20	0.530	5.0
HC-KFS23G2	200	BK3-29B-02MEKA	1/29	0.450	5.0

Model	Output [W]	Variable Dimensions																
		LA	LB	LC	LD	LE	LF	LG	LH	LK	L	LR	KL	LZ	Q	S	P	R
HC-KFS23G2	200	80	65	95	70	6	48	8	60	23	157	55	106.6	6.6	25	16	M4	8
HC-KFS23G2	200	100	80	115	85	6	65	10	74	33	175	75	124.6	6.6	35	20	M5	10
HC-KFS23G2	200	115	95	135	100	8	75	10	85	35	180	85	129.6	9	40	25	M6	12
HC-KFS23G2	200	115	95	135	100	8	75	10	85	35	180	85	129.6	9	40	25	M6	12

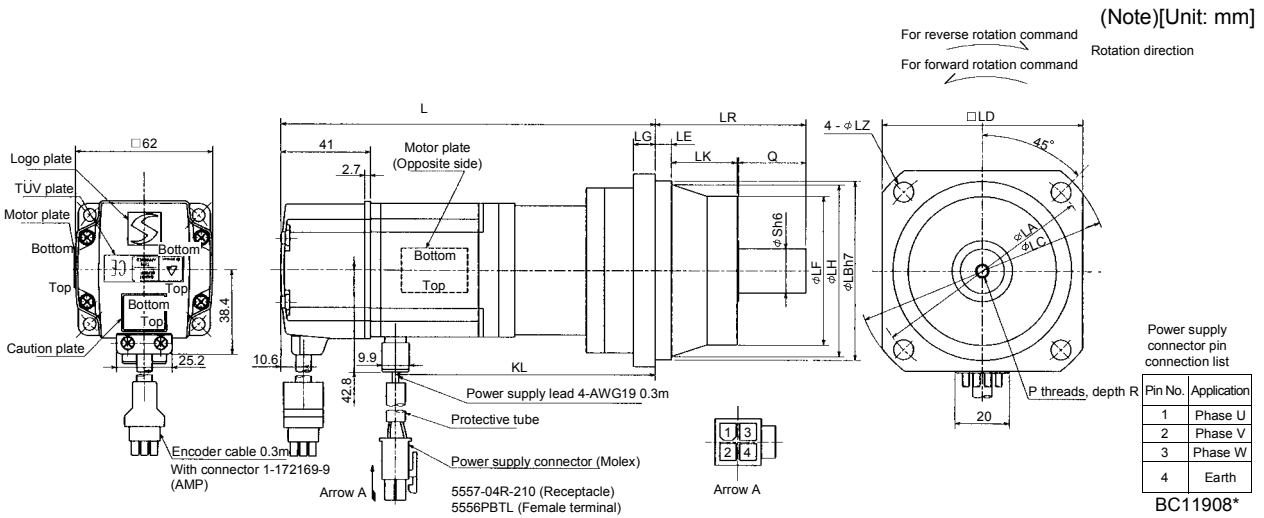

Note: The dimensions without tolerances are reference dimensions.

7. OUTLINE DIMENSION DRAWINGS

Model	Output [W]	Reduction Gear Model	Reduction Ratio	Inertia Moment $J[\times 10^{-4} \text{kg} \cdot \text{m}^2]$	Mass [kg]
HC-MFS43G2	400	BK2-05B-04MEKA	1/5	0.295	3.7
HC-MFS43G2	400	BK3-09B-04MEKA	1/9	0.323	5.3
HC-MFS43G2	400	BK4-20B-04MEKA	1/20	0.426	7.5
HC-MFS43G2	400	BK4-29B-04MEKA	1/29	0.338	7.5

Model	Output [W]	Variable Dimensions																
		LA	LB	LC	LD	LE	LF	LG	LH	LK	L	LR	KL	LZ	Q	S	P	R
HC-MFS43G2	400	100	80	115	85	6	65	10	74	33	184	75	131.6	6.6	35	20	M5	10
HC-MFS43G2	400	115	95	135	100	8	75	10	85	35	205	85	152.6	9	40	25	M6	12
HC-MFS43G2	400	135	110	155	115	8	90	12	100	40	211	100	158.6	11	50	32	M8	16
HC-MFS43G2	400	135	110	155	115	8	90	12	100	40	211	100	158.6	11	50	32	M8	16

Model	Output [W]	Reduction Gear Model	Reduction Ratio	Inertia Moment $J[\times 10^{-4} \text{kg} \cdot \text{m}^2]$	Mass [kg]
HC-KFS43G2	400	BK2-05B-04MEKA	1/5	0.610	3.7
HC-KFS43G2	400	BK3-09B-04MEKA	1/9	0.640	5.3
HC-KFS43G2	400	BK4-20B-04MEKA	1/20	0.740	7.5
HC-KFS43G2	400	BK4-29B-04MEKA	1/29	0.660	7.5

Model	Output [W]	Variable Dimensions																
		LA	LB	LC	LD	LE	LF	LG	LH	LK	L	LR	KL	LZ	Q	S	P	R
HC-KFS43G2	400	100	80	115	85	6	65	10	74	33	184	75	131.6	6.6	35	20	M5	10
HC-KFS43G2	400	115	95	135	100	8	75	10	85	35	205	85	152.6	9	40	25	M6	12
HC-KFS43G2	400	135	110	155	115	8	90	12	100	40	211	100	158.6	11	50	32	M8	16
HC-KFS43G2	400	135	110	155	115	8	90	12	100	40	211	100	158.6	11	50	32	M8	16

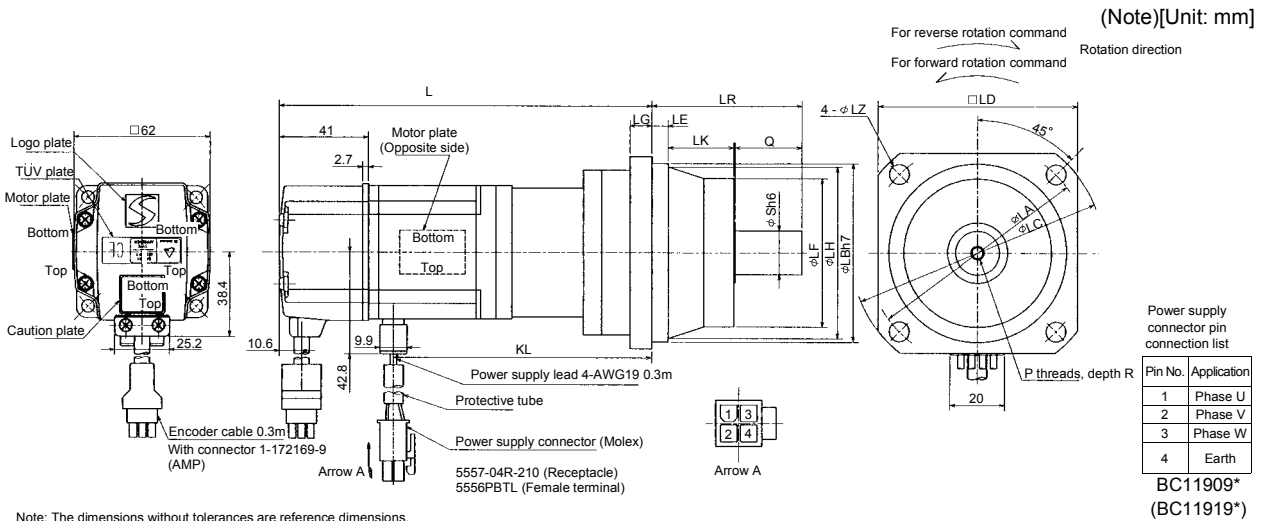

7. OUTLINE DIMENSION DRAWINGS

Model	Output [W]	Reduction Gear Model	Reduction Ratio	Inertia Moment J [$\times 10^{-4}$ kg · m ²]	Mass [kg]
HC-MFS73G2	750	BK3-05B-08MEKA	1/5	0.973	6.3
HC-MFS73G2	750	BK4-09B-08MEKA	1/9	0.980	8.6
HC-MFS73G2	750	BK5-20B-08MEKA	1/20	1.016	12.0
HC-MFS73G2	750	BK5-29B-08MEKA	1/29	0.910	12.0

Model	Output [W]	Variable Dimensions																
		LA	LB	LC	LD	LE	LF	LG	LH	LK	L	LR	KL	LZ	Q	S	P	R
HC-MFS73G2	750	115	95	135	100	8	75	10	85	35	212	85	156.7	9	40	25	M6	12
HC-MFS73G2	750	135	110	155	115	8	90	12	100	40	240	100	184.7	11	50	32	M8	16
HC-MFS73G2	750	150	125	175	130	10	105	15	115	43	248	115	192.7	14	60	40	M10	20
HC-MFS73G2	750	150	125	175	130	10	105	15	115	43	248	115	192.7	14	60	40	M10	20

Model	Output [W]	Reduction Gear Model	Reduction Ratio	Inertia Moment J [$\times 10^{-4}$ kg · m ²]	Mass [kg]
HC-KFS73G2	750	BK3-05B-08MEKA	1/5	1.883	6.3
HC-KFS73G2	750	BK4-09B-08MEKA	1/9	1.890	8.6
HC-KFS73G2	750	BK5-20B-08MEKA	1/20	1.926	12.0
HC-KFS73G2	750	BK5-29B-08MEKA	1/29	1.820	12.0

Model	Output [W]	Variable Dimensions																
		LA	LB	LC	LD	LE	LF	LG	LH	LK	L	LR	KL	LZ	Q	S	P	R
HC-KFS73G2	750	115	95	135	100	8	75	10	85	35	212	85	156.7	9	40	25	M6	12
HC-KFS73G2	750	135	110	155	115	8	90	12	100	40	240	100	184.7	11	50	32	M8	16
HC-KFS73G2	750	150	125	175	130	10	105	15	115	43	248	115	192.7	14	60	40	M10	20
HC-KFS73G2	750	150	125	175	130	10	105	15	115	43	248	115	192.7	14	60	40	M10	20

(Note)[Unit: mm]

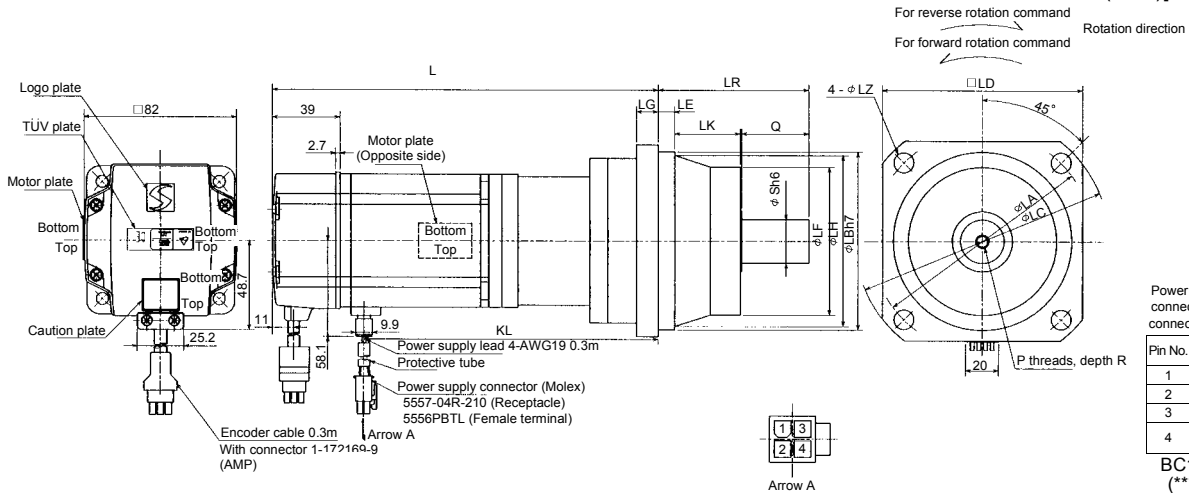

Note: The dimensions without tolerances are reference dimensions.

7. OUTLINE DIMENSION DRAWINGS

(b) With electromagnetic brake

Model	Output [W]	Variable Dimensions		Brake static friction torque [N · m]	Reduction Gear Model	Reduction Ratio	Inertia Moment J [$\times 10^{-4}$ kg · m ²]	Backlash	Mass [kg]
		L	KL						
HC-MFS053BG2	50	158	78	0.32	BK1-05B-A5MEKA	1/5	0.070	3 min. max.	1.8
HC-MFS053BG2	50	174	94	0.32	BK1-09B-A5MEKA	1/9	0.063	3 min. max.	2.1
HC-MFS053BG2	50	174	94	0.32	BK1-20B-A5MEKA	1/20	0.072	3 min. max.	2.2
HC-MFS053BG2	50	174	94	0.32	BK1-29B-A5MEKA	1/29	0.060	3 min. max.	2.2
HC-KFS053BG2	50	158	78	0.32	BK1-05B-A5MEKA	1/5	0.104	3 min. max.	1.8
HC-KFS053BG2	50	174	94	0.32	BK1-09B-A5MEKA	1/9	0.098	3 min. max.	2.1
HC-KFS053BG2	50	174	94	0.32	BK1-20B-A5MEKA	1/20	0.107	3 min. max.	2.2
HC-KFS053BG2	50	174	94	0.32	BK1-29B-A5MEKA	1/29	0.095	3 min. max.	2.2

(Note)[Unit: mm]

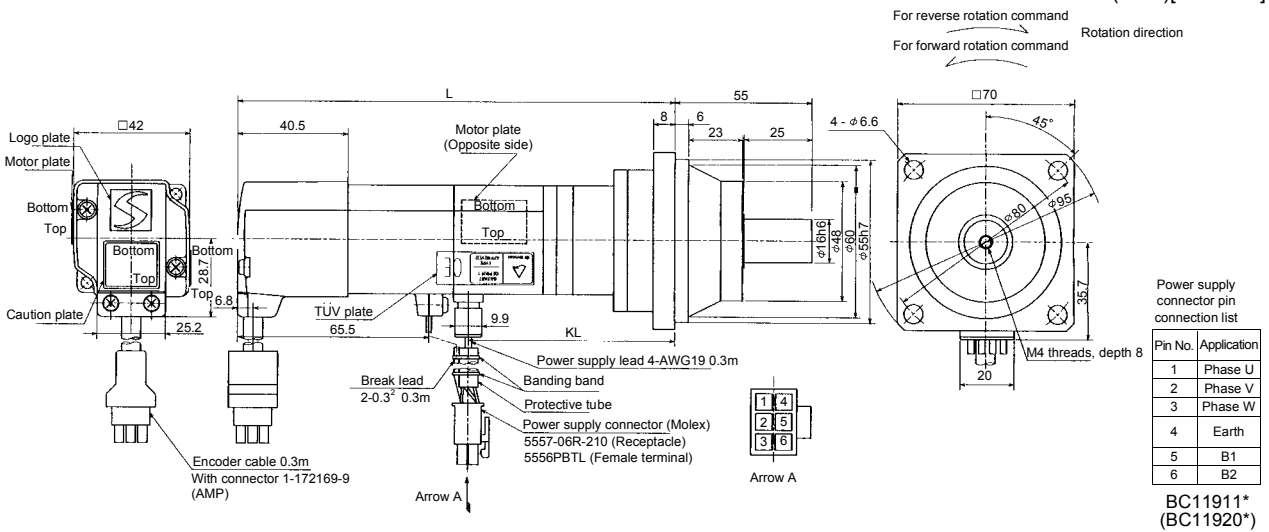

Note: The dimensions without tolerances are reference dimensions.

7. OUTLINE DIMENSION DRAWINGS

Model	Output [W]	Brake static friction torque [N · m]	Reduction Gear Model	Reduction Ratio	Inertia Moment $J[\times 10^{-4} \text{ kg} \cdot \text{m}^2]$	Backlash	Mass [kg]
HC-MFS13BG2	100	0.32	BK1-05B-01MEKA	1/5	0.080	3 min. max.	1.9
HC-MFS13BG2	100	0.32	BK1-09B-01MEKA	1/9	0.074	3 min. max.	2.2
HC-MFS13BG2	100	0.32	BK2-20B-01MEKA	1/20	0.124	3 min. max.	3.4
HC-MFS13BG2	100	0.32	BK2-29B-01MEKA	1/29	0.098	3 min. max.	3.4

Model	Output [W]	Variable Dimensions																
		LA	LB	LC	LD	LE	LF	LG	LH	LK	L	LR	KL	LZ	Q	S	P	R
HC-MFS13BG2	100	80	65	95	70	6	48	8	60	23	173	55	93	6.6	25	16	M4	8
HC-MFS13BG2	100	80	65	95	70	6	48	8	60	23	189	55	109	6.6	25	16	M4	8
HC-MFS13BG2	100	100	80	115	85	6	65	10	74	33	195	75	115	6.6	35	20	M5	10
HC-MFS13BG2	100	100	80	115	85	6	65	10	74	33	195	75	115	6.6	35	20	M5	10

Model	Output [W]	Brake static friction torque [N · m]	Reduction Gear Model	Reduction Ratio	Inertia Moment $J[\times 10^{-4} \text{ kg} \cdot \text{m}^2]$	Backlash	Mass [kg]
HC-KFS13BG2	100	0.32	BK1-05B-01MEKA	1/5	0.135	3 min. max.	1.9
HC-KFS13BG2	100	0.32	BK1-09B-01MEKA	1/9	0.129	3 min. max.	2.2
HC-KFS13BG2	100	0.32	BK2-20B-01MEKA	1/20	0.179	3 min. max.	3.4
HC-KFS13BG2	100	0.32	BK2-29B-01MEKA	1/29	0.153	3 min. max.	3.4

Model	Output [W]	Variable Dimensions																
		LA	LB	LC	LD	LE	LF	LG	LH	LK	L	LR	KL	LZ	Q	S	P	R
HC-KFS13BG2	100	80	65	95	70	6	48	8	60	23	173	55	93	6.6	25	16	M4	8
HC-KFS13BG2	100	80	65	95	70	6	48	8	60	23	189	55	109	6.6	25	16	M4	8
HC-KFS13BG2	100	100	80	115	85	6	65	10	74	33	195	75	115	6.6	35	20	M5	10
HC-KFS13BG2	100	100	80	115	85	6	65	10	74	33	195	75	115	6.6	35	20	M5	10

(Note)[Unit: mm]

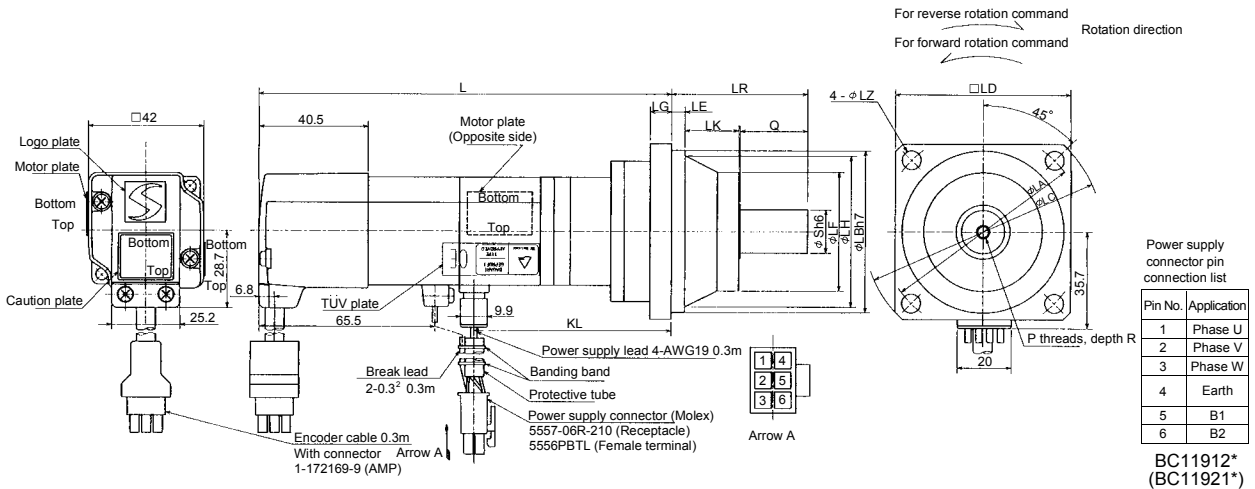

Note: The dimensions without tolerances are reference dimensions.

7. OUTLINE DIMENSION DRAWINGS

Model	Output [W]	Brake static friction torque [N · m]	Reduction Gear Model	Reduction Ratio	Inertia Moment $J[\times 10^{-4} \text{ kg} \cdot \text{m}^2]$	Mass [kg]
HC-MFS23BG2	200	1.3	BK1-05B-02MEKA	1/5	0.239	2.7
HC-MFS23BG2	200	1.3	BK2-09B-02MEKA	1/9	0.256	4.1
HC-MFS23BG2	200	1.3	BK3-20B-02MEKA	1/20	0.405	5.6
HC-MFS23BG2	200	1.3	BK3-29B-02MEKA	1/29	0.324	5.6

Model	Output [W]	Variable Dimensions																
		LA	LB	LC	LD	LE	LF	LG	LH	LK	L	LR	KL	LZ	Q	S	P	R
HC-MFS23BG2	200	80	65	95	70	6	48	8	60	23	189	55	106.6	6.6	25	16	M4	8
HC-MFS23BG2	200	100	80	115	85	6	65	10	74	33	207	75	124.6	6.6	35	20	M5	10
HC-MFS23BG2	200	115	95	135	100	8	75	10	85	35	212	85	129.6	9	40	25	M6	12
HC-MFS23BG2	200	115	95	135	100	8	75	10	85	35	212	85	129.6	9	40	25	M6	12

Model	Output [W]	Brake static friction torque [N · m]	Reduction Gear Model	Reduction Ratio	Inertia Moment $J[\times 10^{-4} \text{ kg} \cdot \text{m}^2]$	Mass [kg]
HC-KFS23BG2	200	1.3	BK1-05B-02MEKA	1/5	0.410	2.7
HC-KFS23BG2	200	1.3	BK2-09B-02MEKA	1/9	0.430	4.1
HC-KFS23BG2	200	1.3	BK3-20B-02MEKA	1/20	0.580	5.6
HC-KFS23BG2	200	1.3	BK3-29B-02MEKA	1/29	0.500	5.6

Model	Output [W]	Variable Dimensions																
		LA	LB	LC	LD	LE	LF	LG	LH	LK	L	LR	KL	LZ	Q	S	P	R
HC-KFS23BG2	200	80	65	95	70	6	48	8	60	23	189	55	106.6	6.6	25	16	M4	8
HC-KFS23BG2	200	100	80	115	85	6	65	10	74	33	207	75	124.6	6.6	35	20	M5	10
HC-KFS23BG2	200	115	95	135	100	8	75	10	85	35	212	85	129.6	9	40	25	M6	12
HC-KFS23BG2	200	115	95	135	100	8	75	10	85	35	212	85	129.6	9	40	25	M6	12

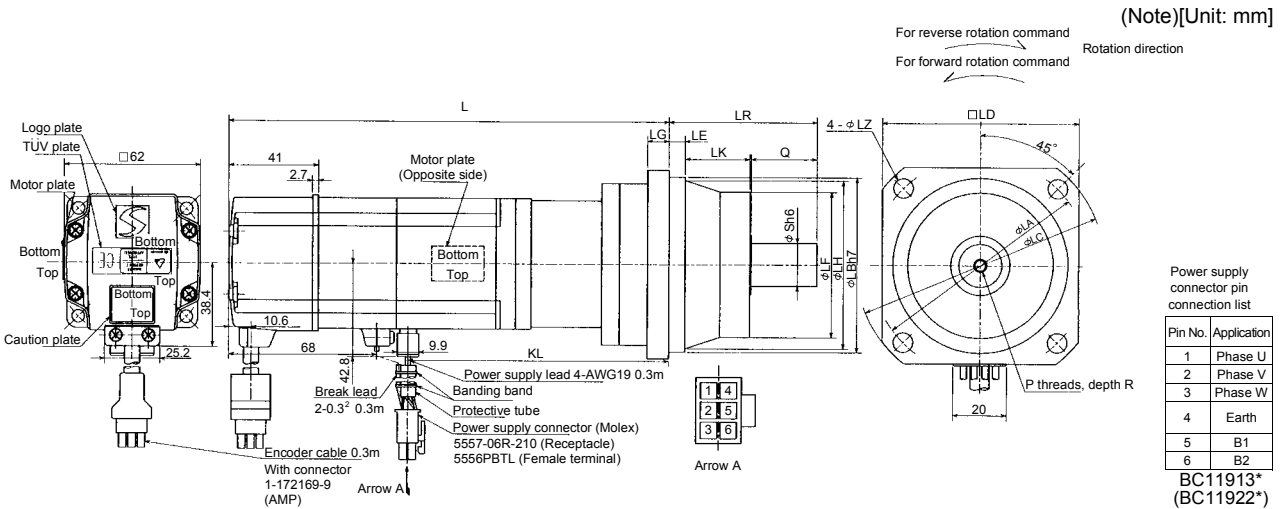

Note: The dimensions without tolerances are reference dimensions.

7. OUTLINE DIMENSION DRAWINGS

Model	Output [W]	Brake static friction torque [N · m]	Reduction Gear Model	Reduction Ratio	Inertia Moment $J[\times 10^{-4} \text{ kg} \cdot \text{m}^2]$	Mass [kg]
HC-MFS43BG2	400	1.3	BK2-05B-04MEKA	1/5	0.344	4.3
HC-MFS43BG2	400	1.3	BK3-09B-04MEKA	1/9	0.372	5.9
HC-MFS43BG2	400	1.3	BK4-20B-04MEKA	1/20	0.475	8.1
HC-MFS43BG2	400	1.3	BK4-29B-04MEKA	1/29	0.386	8.1

Model	Output [W]	Variable Dimensions																
		LA	LB	LC	LD	LE	LF	LG	LH	LK	L	LR	KL	LZ	Q	S	P	R
HC-MFS43BG2	400	100	80	115	85	6	65	10	74	33	216	75	131.6	6.6	35	20	M5	10
HC-MFS43BG2	400	115	95	135	100	8	75	10	85	35	237	85	152.6	9	40	25	M6	12
HC-MFS43BG2	400	135	110	155	115	8	90	12	100	40	243	100	158.6	11	50	32	M8	16
HC-MFS43BG2	400	135	110	155	115	8	90	12	100	40	243	100	158.6	11	50	32	M8	16

Model	Output [W]	Brake static friction torque [N · m]	Reduction Gear Model	Reduction Ratio	Inertia Moment $J[\times 10^{-4} \text{ kg} \cdot \text{m}^2]$	Mass [kg]
HC-KFS43BG2	400	1.3	BK2-05B-04MEKA	1/5	0.660	4.3
HC-KFS43BG2	400	1.3	BK3-09B-04MEKA	1/9	0.690	5.9
HC-KFS43BG2	400	1.3	BK4-20B-04MEKA	1/20	0.790	8.1
HC-KFS43BG2	400	1.3	BK4-29B-04MEKA	1/29	0.710	8.1

Model	Output [W]	Variable Dimensions																
		LA	LB	LC	LD	LE	LF	LG	LH	LK	L	LR	KL	LZ	Q	S	P	R
HC-KFS43BG2	400	100	80	115	85	6	65	10	74	33	216	75	131.6	6.6	35	20	M5	10
HC-KFS43BG2	400	115	95	135	100	8	75	10	85	35	237	85	152.6	9	40	25	M6	12
HC-KFS43BG2	400	135	110	155	115	8	90	12	100	40	243	100	158.6	11	50	32	M8	16
HC-KFS43BG2	400	135	110	155	115	8	90	12	100	40	243	100	158.6	11	50	32	M8	16

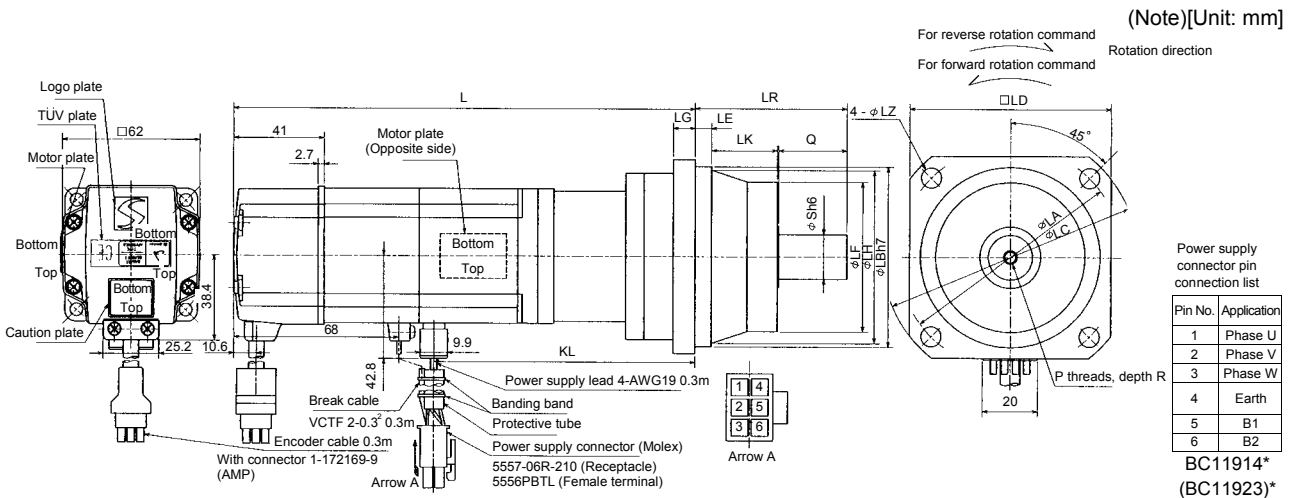

7. OUTLINE DIMENSION DRAWINGS

Model	Output [W]	Brake static friction torque [N · m]	Reduction Gear Model	Reduction Ratio	Inertia Moment $J[\times 10^{-4} \text{ kg} \cdot \text{m}^2]$	Mass [kg]
HC-MFS73BG2	750	2.4	BK3-05B-08MEKA	1/5	1.098	7.3
HC-MFS73BG2	750	2.4	BK4-09B-08MEKA	1/9	1.105	9.6
HC-MFS73BG2	750	2.4	BK5-20B-08MEKA	1/20	1.141	13.0
HC-MFS73BG2	750	2.4	BK5-29B-08MEKA	1/29	1.035	13.0

Model	Output [W]	Variable Dimensions																
		LA	LB	LC	LD	LE	LF	LG	LH	LK	L	LR	KL	LZ	Q	S	P	R
HC-MFS73BG2	750	115	95	135	100	8	75	10	85	35	247.5	85	156.7	9	40	25	M6	12
HC-MFS73BG2	750	135	110	155	115	8	90	12	100	40	275.5	100	184.7	11	50	32	M8	16
HC-MFS73BG2	750	150	125	175	130	10	105	15	115	43	283.5	115	192.7	14	60	40	M10	20
HC-MFS73BG2	750	150	125	175	130	10	105	15	115	43	283.5	115	192.7	14	60	40	M10	20

Model	Output [W]	Brake static friction torque [N · m]	Reduction Gear Model	Reduction Ratio	Inertia Moment $J[\times 10^{-4} \text{ kg} \cdot \text{m}^2]$	Mass [kg]
HC-KFS73BG2	750	2.4	BK3-05B-08MEKA	1/5	2.008	7.3
HC-KFS73BG2	750	2.4	BK4-09B-08MEKA	1/9	2.015	9.6
HC-KFS73BG2	750	2.4	BK5-20B-08MEKA	1/20	2.051	13.0
HC-KFS73BG2	750	2.4	BK5-29B-08MEKA	1/29	1.945	13.0

Model	Output [W]	Variable Dimensions																
		LA	LB	LC	LD	LE	LF	LG	LH	LK	L	LR	KL	LZ	Q	S	P	R
HC-KFS73BG2	750	115	95	135	100	8	75	10	85	35	247.5	85	156.7	9	40	25	M6	12
HC-KFS73BG2	750	135	110	155	115	8	90	12	100	40	275.5	100	184.7	11	50	32	M8	16
HC-KFS73BG2	750	150	125	175	130	10	105	15	115	43	283.5	115	192.7	14	60	40	M10	20
HC-KFS73BG2	750	150	125	175	130	10	105	15	115	43	283.5	115	192.7	14	60	40	M10	20

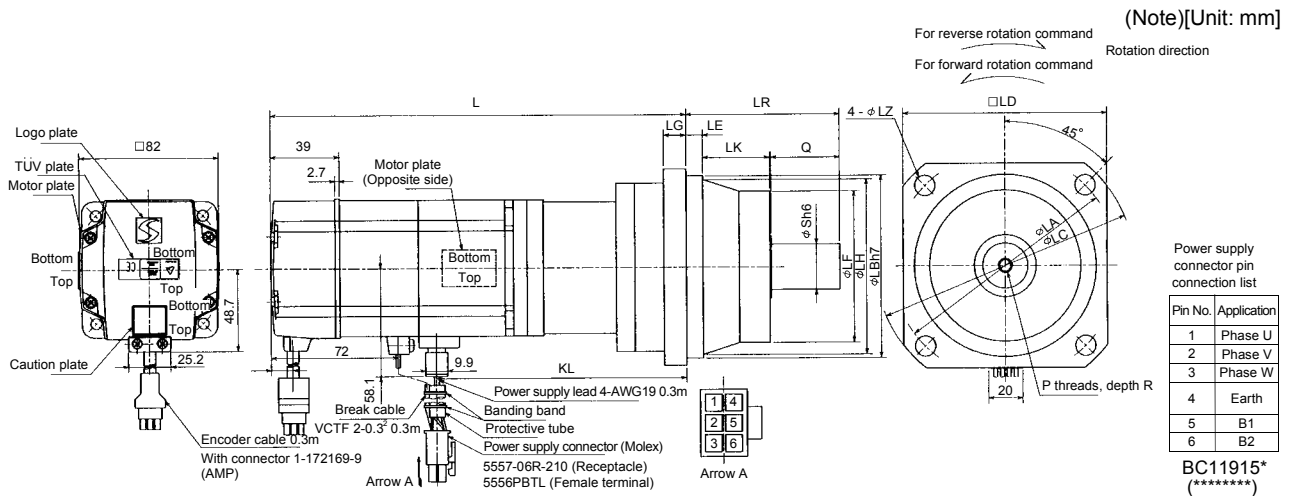

Note: The dimensions without tolerances are reference dimensions.

7. OUTLINE DIMENSION DRAWINGS

7.1.12 HC-UFS 3000r/min series

(1) Standard (without electromagnetic brake)

Model	Output [W]	Inertia Moment J [$\times 10^{-4} \text{ kg} \cdot \text{m}^2$]	Mass [kg]
HC-UFS13	100	0.066	0.8

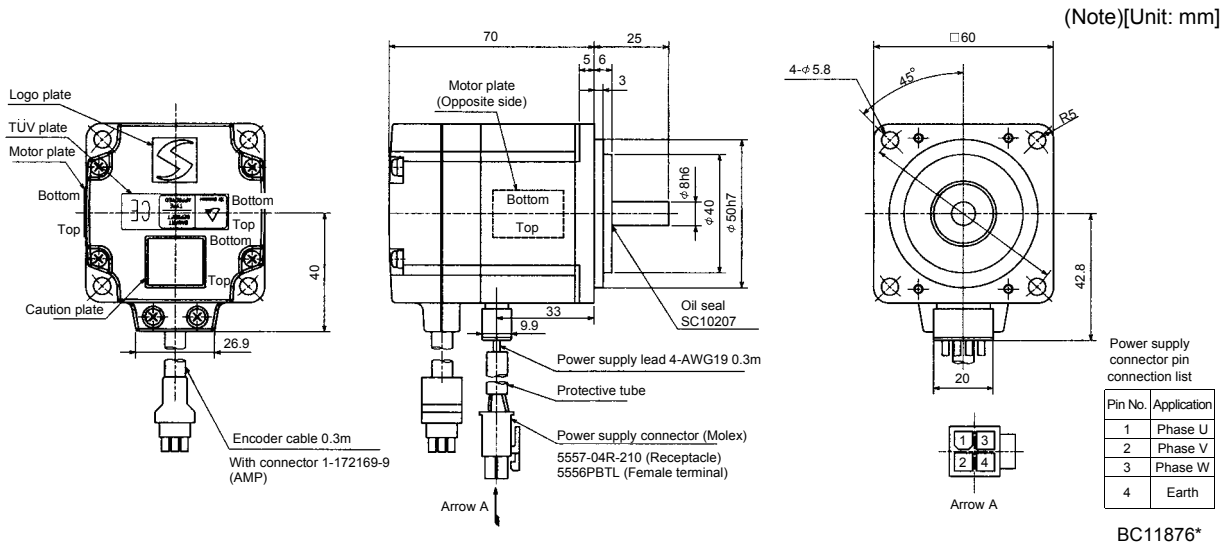

Note: The dimensions without tolerances are reference dimensions.

Model	Output [W]	Variable Dimensions		Inertia Moment J [$\times 10^{-4} \text{ kg} \cdot \text{m}^2$]	Mass [kg]
		L	KL		
HC-UFS23	200	77	43.8	0.241	1.5
HC-UFS43	400	92	58.8	0.365	1.7

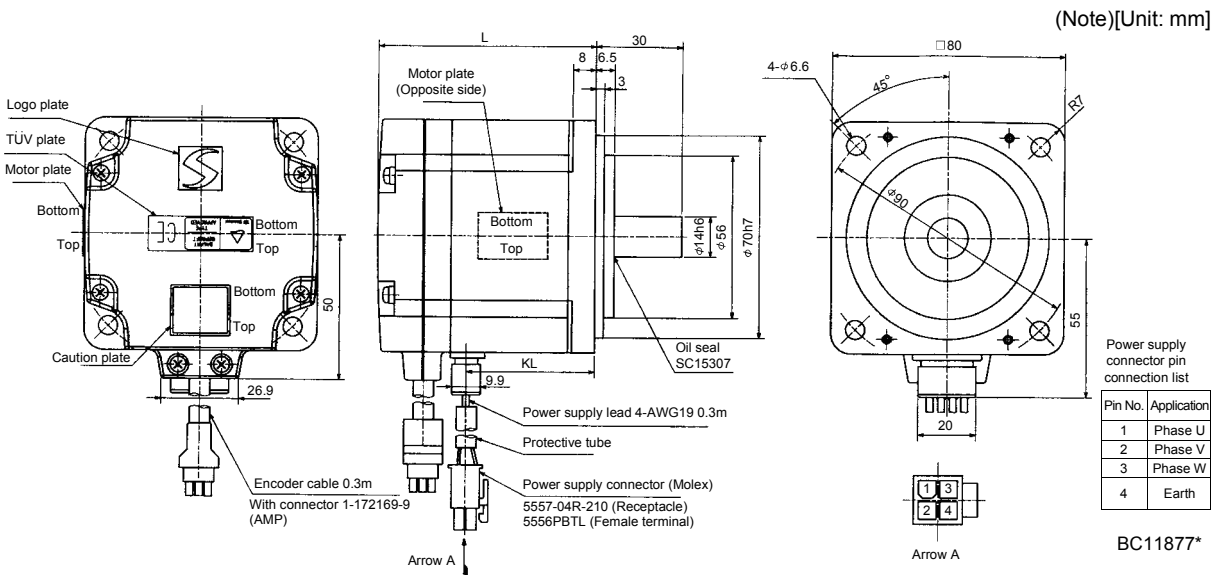

Note: The dimensions without tolerances are reference dimensions.

7. OUTLINE DIMENSION DRAWINGS

Model	Output [W]	Inertia Moment $J[\times 10^{-4} \text{kg} \cdot \text{m}^2]$	Mass [kg]
HC-UFS73	750	5.9	5.0

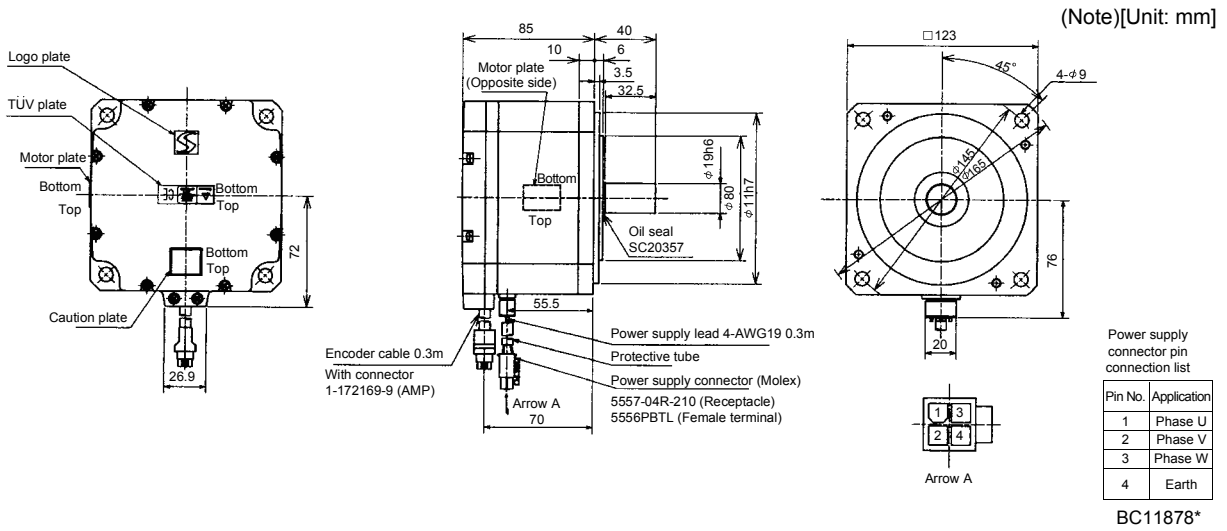

Note: The dimensions without tolerances are reference dimensions.

(2) With electromagnetic brake

Model	Output [W]	Brake static friction torque [N · m]	Inertia Moment $J[\times 10^{-4} \text{kg} \cdot \text{m}^2]$	Mass [kg]
HC-UFS13B	100	0.32	0.074	1.2

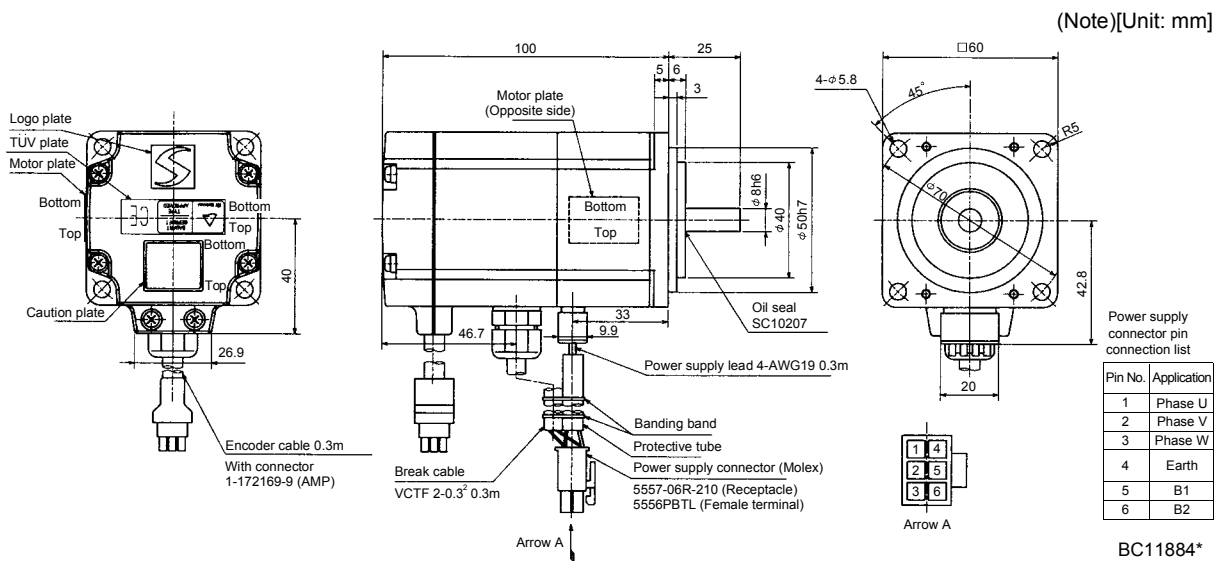

Note: The dimensions without tolerances are reference dimensions.

7. OUTLINE DIMENSION DRAWINGS

Model	Output [W]	Variable Dimensions		Brake static friction torque [N · m]	Inertia Moment $J[\times 10^{-4} \text{kg} \cdot \text{m}^2]$	Mass [kg]
		L	KL			
HC-UFS23B	200	111	43.8	1.3	0.323	2.2
HC-UFS43B	400	126	58.8	1.3	0.447	2.4

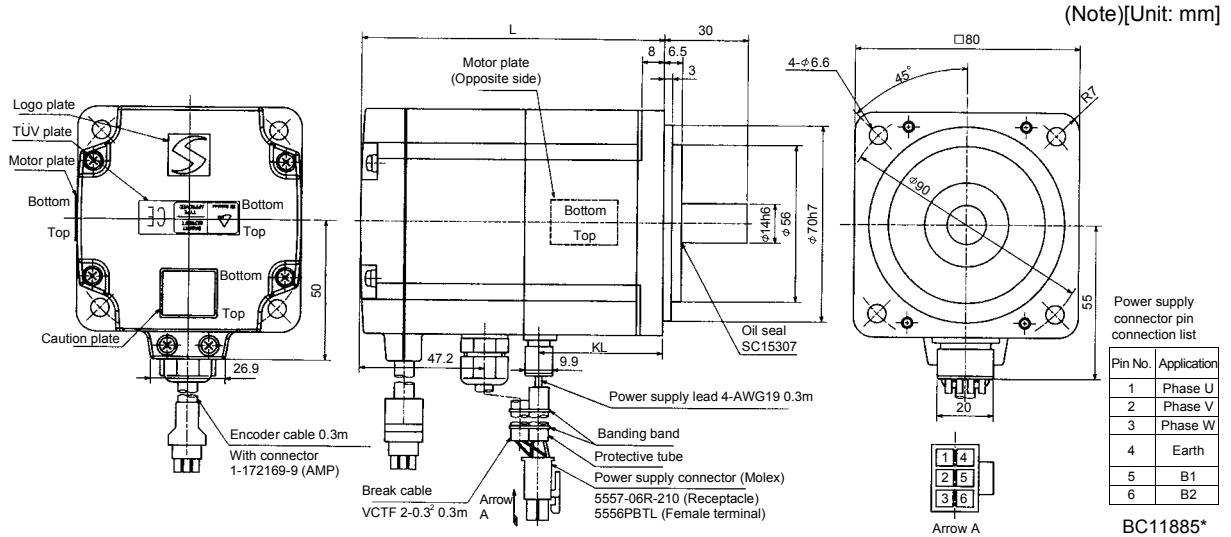

Note: The dimensions without tolerances are reference dimensions.

Model	Output [W]	Brake static friction torque [N · m]	Inertia Moment $J[\times 10^{-4} \text{kg} \cdot \text{m}^2]$	Mass [kg]
HC-UFS73B	750	2.4	6.1	6.2

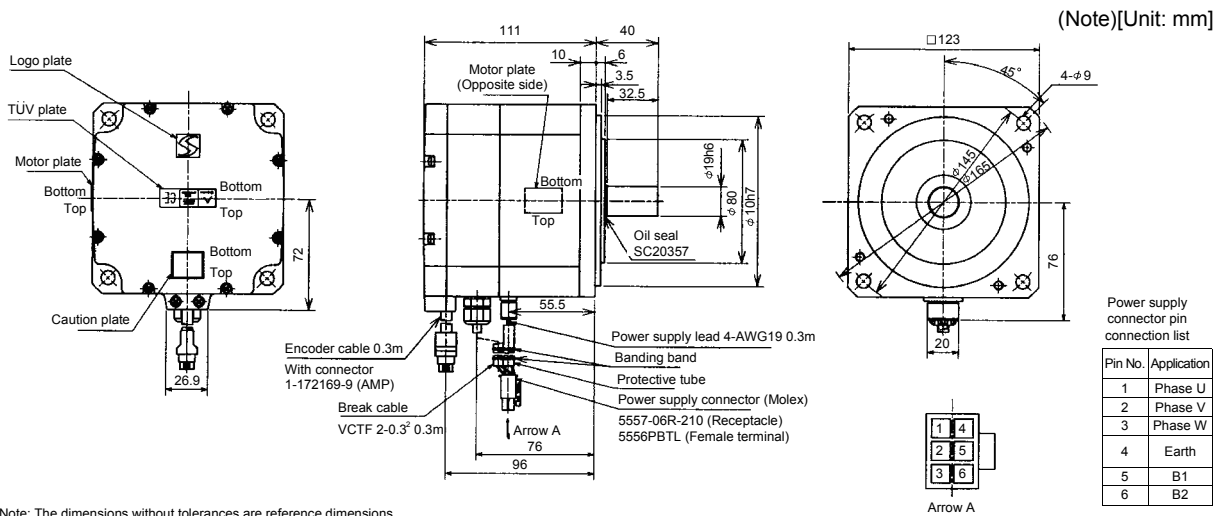

Note: The dimensions without tolerances are reference dimensions.

7. OUTLINE DIMENSION DRAWINGS

7.1.13 HA-LFS series

Terminal box detail diagram

Motor Model	HA-LFS15K1	HA-LFS25K1 to 37K1 HA-LFS30K1M • 37K1M HA-LFS30K2 • 37K2 HA-LFS25K14 to 37K14 HA-LFS37K1M4 to 50K1M4 HA-LFS45K24 • 55K24	
	HA-LFS20K1		
	HA-LFS22K1M		
	HA-LFS15K14		
	HA-LFS20K14		
	HA-LFS22K1M4		
	HA-LFS30K1M4		
Motor power supply lead size	8mm ² (AWG8) × 2 parallel	22mm ² (AWG4) × 2 parallel	
Motor power supply terminal block screw size	M8	M10	
Terminal box dimensions (mm)	LA	220	266
	LB	210	230

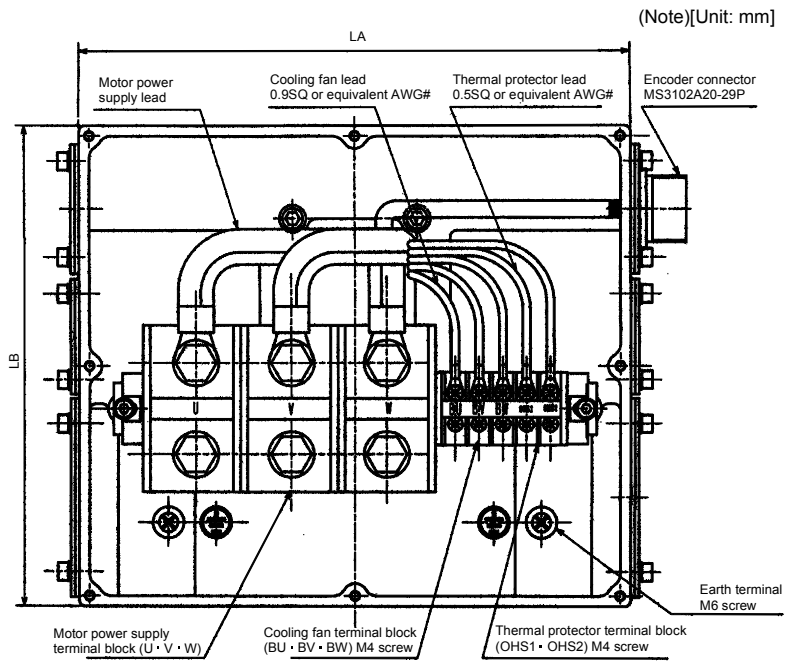

HA-LFS 601 • 701M • 11K2 • 6014 • 701M4 • 11K24 terminal box detail diagram

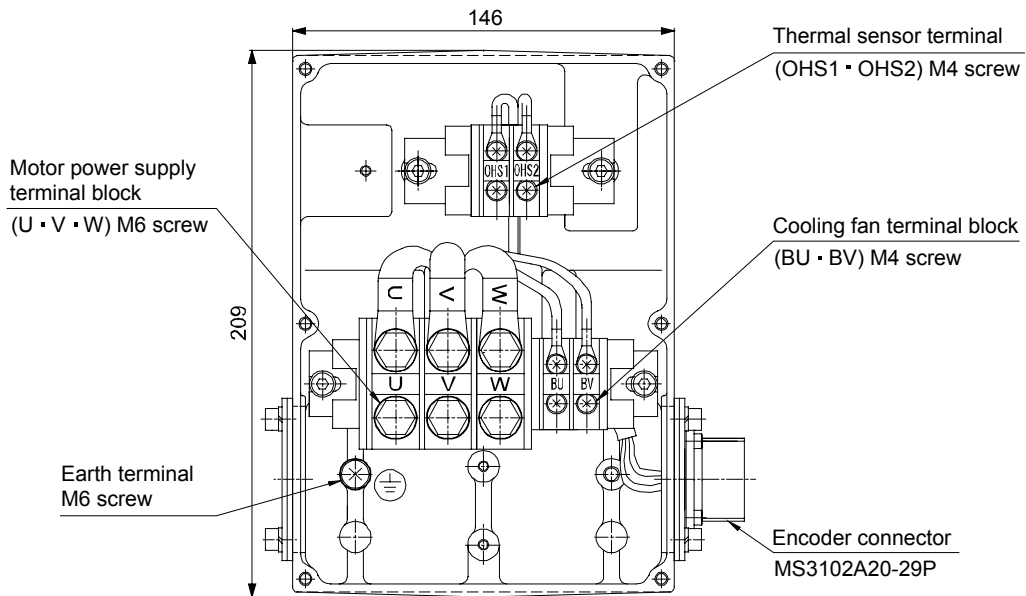

Note. The dimensions without tolerances are reference dimensions.

7. OUTLINE DIMENSION DRAWINGS

HA-LFS 801 · 12K1 · 11K1M · 15K1M · 15K2 · 22K2 · 8014 · 12K14 · 11K1M4 · 15K1M4 · 15K24 · 22K24
terminal box detail diagram

(Note)[Unit: mm]

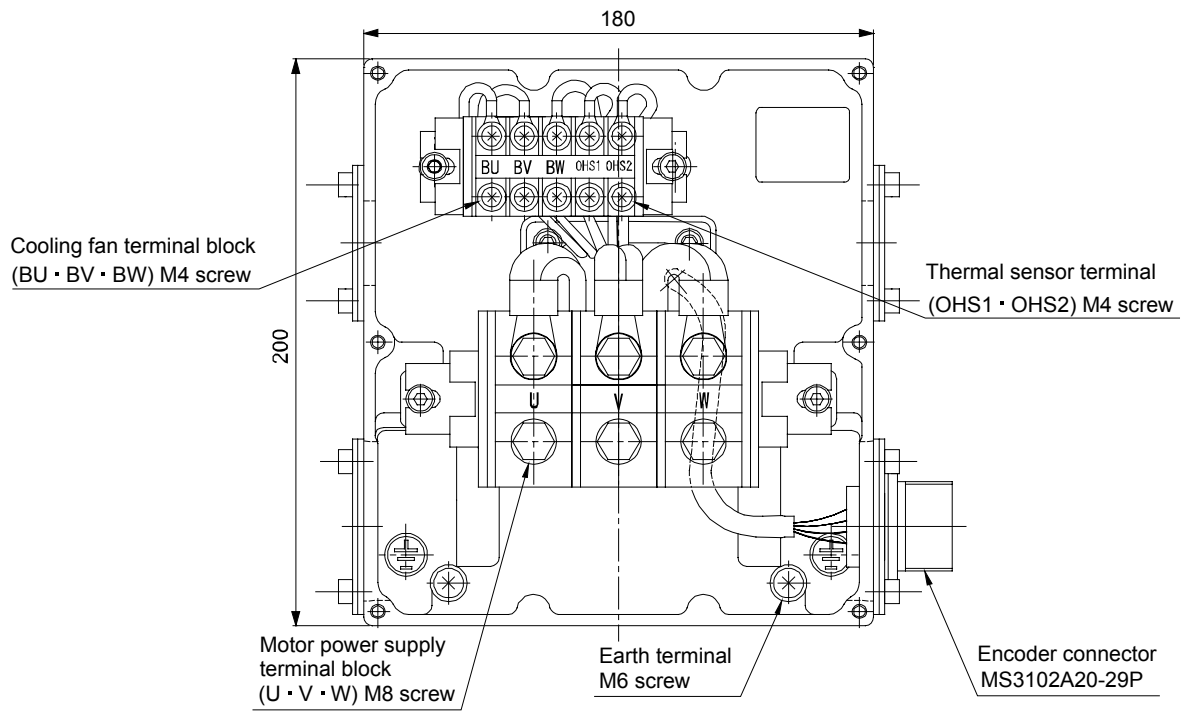

BG72706

Note. The dimensions without tolerances are reference dimensions.

7. OUTLINE DIMENSION DRAWINGS

(1) Standard (Without electromagnetic brake, without reduction gear)

Model	Output [kW]	Inertia Moment $J[\times 10^{-4} \text{kg} \cdot \text{m}^2]$	Mass [kg]
HA-LFS502	5	74.0	28

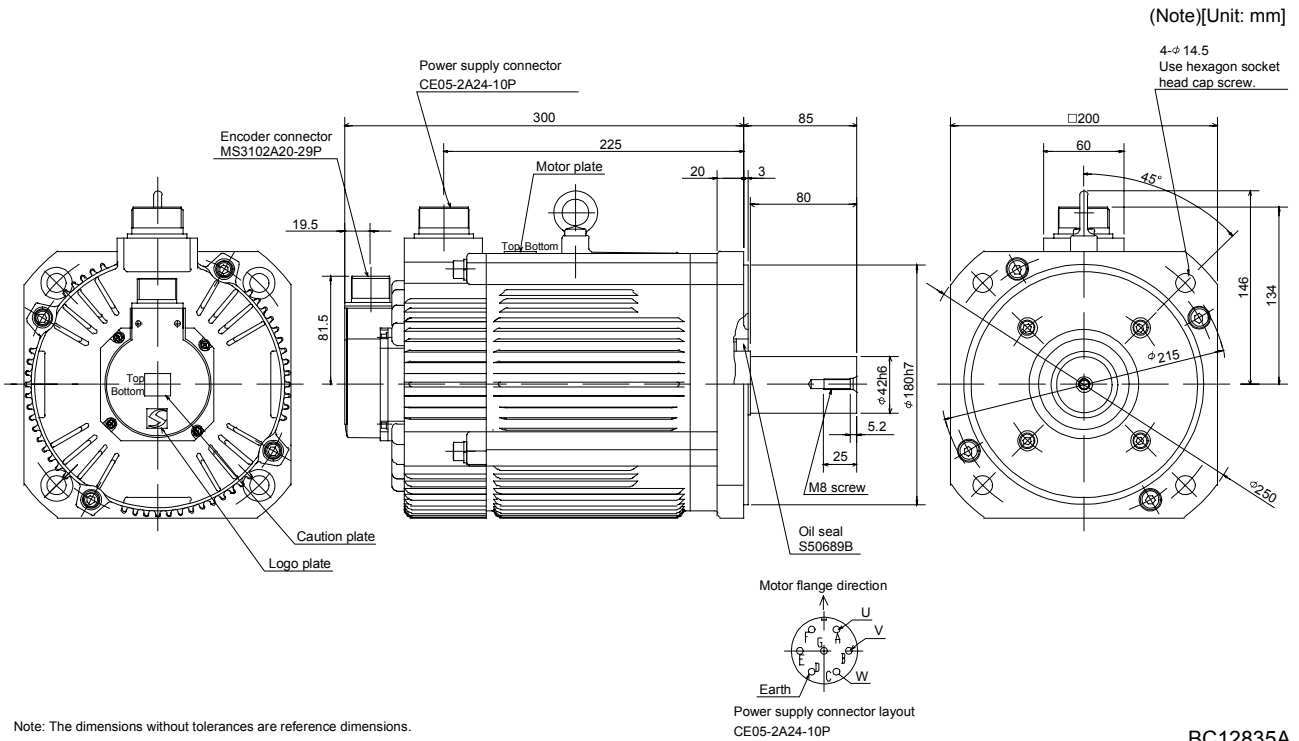

BC12835A

Model	Output [kW]	Inertia Moment $J[\times 10^{-4} \text{kg} \cdot \text{m}^2]$	Mass [kg]
HA-LFS702	7	94.2	35

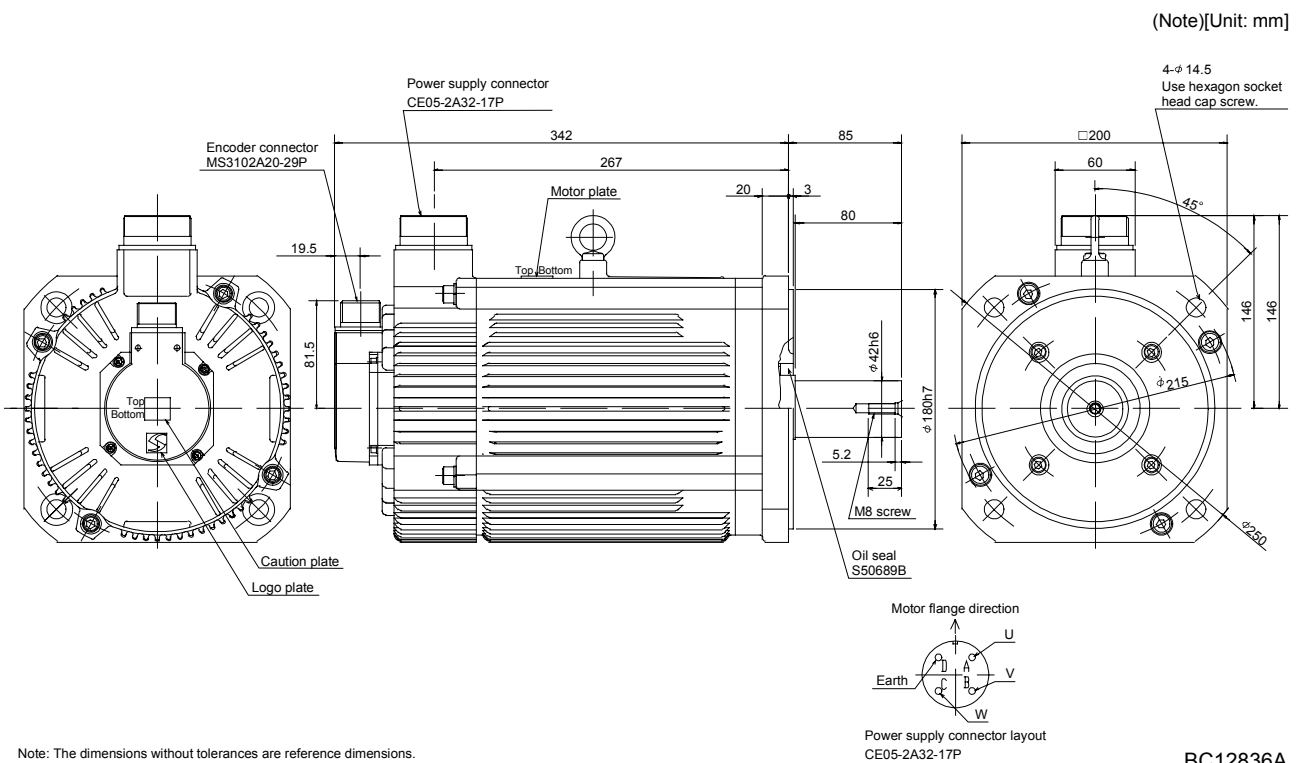

BC12836A

7. OUTLINE DIMENSION DRAWINGS

Model	Output [kW]	Inertia Moment J [$\times 10^{-4} \text{kg} \cdot \text{m}^2$]	Mass [kg]
HA-LFS601 HA-LFS6014	6	105	55
HA-LFS701M HA-LFS701M4	7		
HA-LFS11K2 HA-LFS11K24	11		

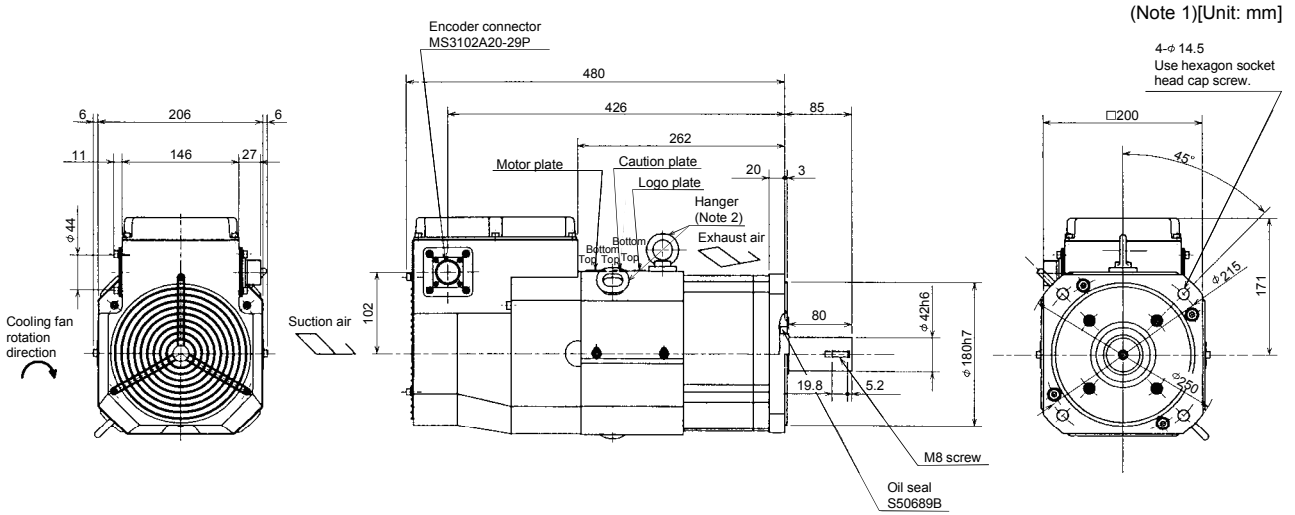

Note 1. The dimensions without tolerances are reference dimensions.
2. When the motor is used without the hanger, plug the threaded hole with a bolt of M12 X 20 mm or less.

Model	Output [kW]	Inertia Moment J [$\times 10^{-4} \text{kg} \cdot \text{m}^2$]	Mass [kg]
HA-LFS801 HA-LFS8014	8	220	95
HA-LFS11K1M HA-LFS11K1M4	11		
HA-LFS15K2 HA-LFS15K24	15		

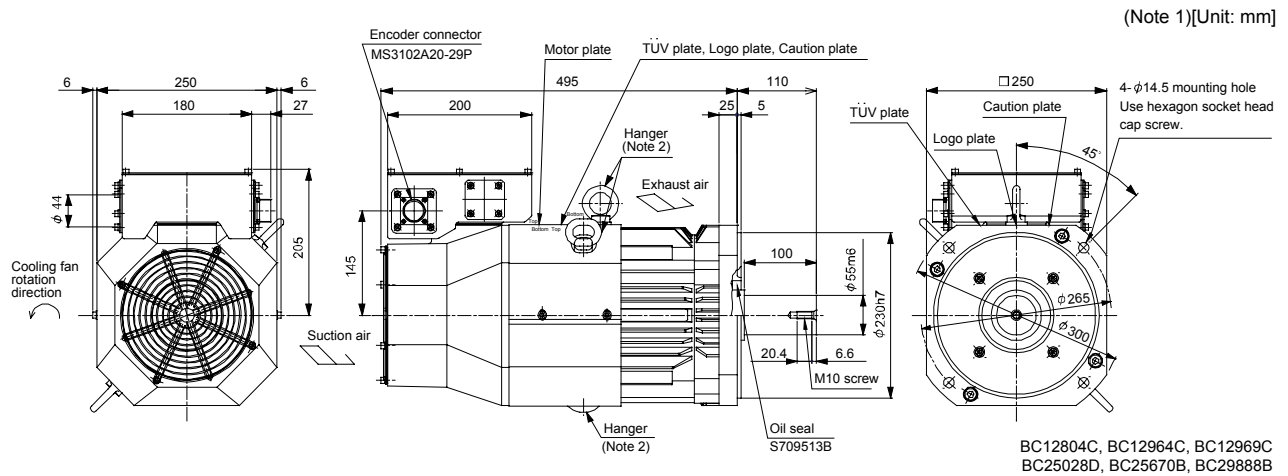

Note 1. The dimensions without tolerances are reference dimensions.
2. When the motor is used without the hanger, plug the threaded hole with a bolt of M12 X 20 mm or less.

7. OUTLINE DIMENSION DRAWINGS

Model	Output [kW]	Inertia Moment $J[\times 10^{-4} \text{kg} \cdot \text{m}^2]$	Mass [kg]
HA-LFS12K1 HA-LFS12K14	12	295	115
HA-LFS15K1M HA-LFS15K1M4	15		
HA-LFS22K2 HA-LFS22K24	22		

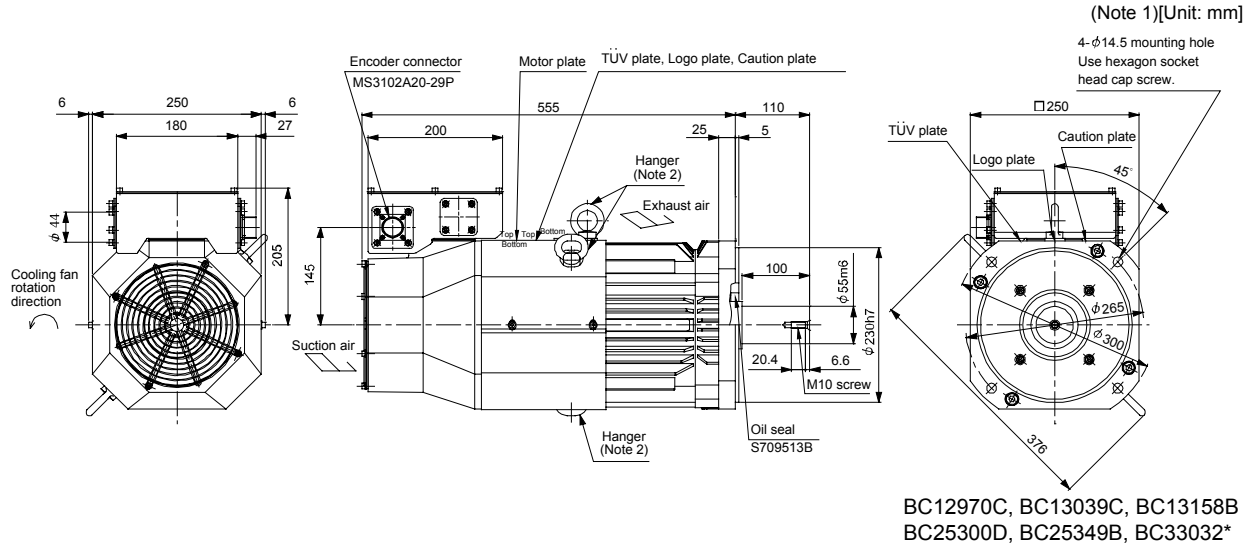

Note 1. The dimensions without tolerances are reference dimensions.

2. When the motor is used without the hanger, plug the threaded hole with a bolt of M12 X 20 mm or less.

Model	Output [kW]	Inertia Moment $J[\times 10^{-4} \text{kg} \cdot \text{m}^2]$	Mass [kg]
HA-LFS15K1 HA-LFS15K14	15	550	160
HA-LFS22K1M HA-LFS22K1M4	22		
HA-LFS30K24	30		

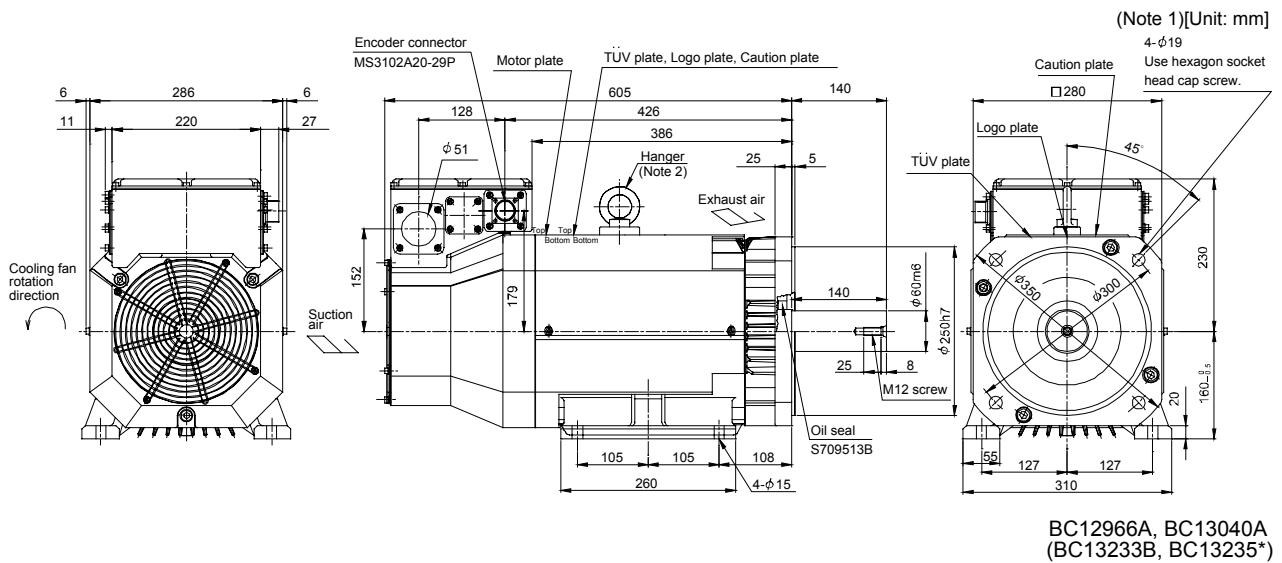

Note 1. The dimensions without tolerances are reference dimensions.

2. When the motor is used without the hanger, plug the threaded hole with a bolt of M16 X 20 mm or less.

7. OUTLINE DIMENSION DRAWINGS

Model	Output [kW]	Inertia Moment $J[\times 10^{-4} \text{kg} \cdot \text{m}^2]$	Mass [kg]
HA-LFS20K1 HA-LFS20K14	20	650	180
HA-LFS30K1M4	30		
HA-LFS37K24	37		

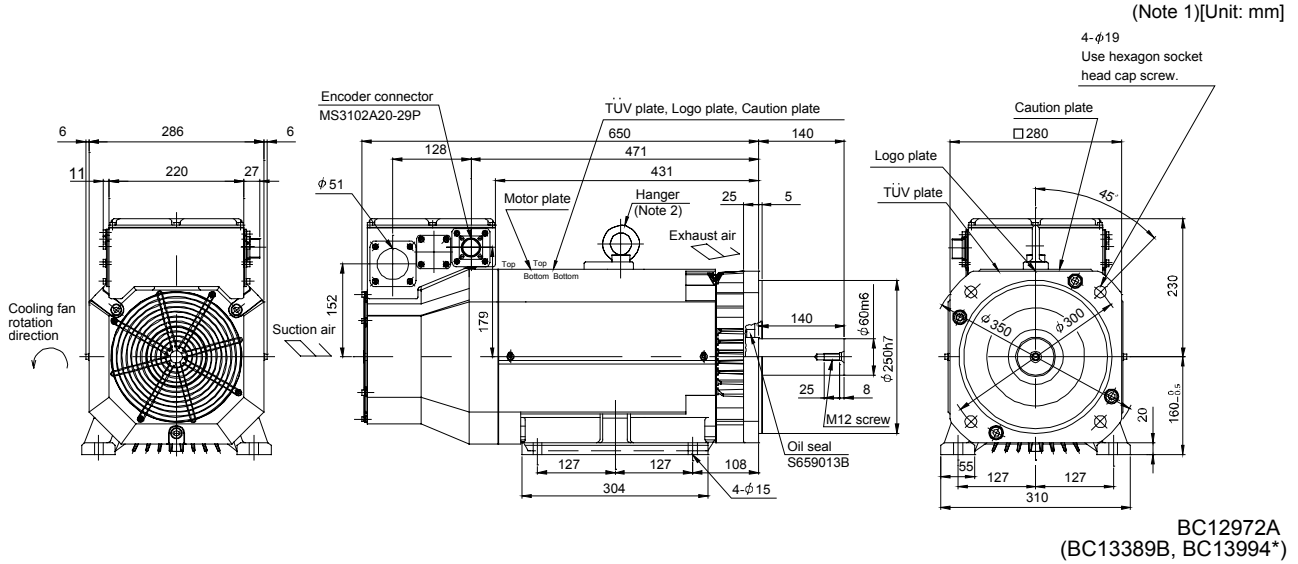

Note 1. The dimensions without tolerances are reference dimensions.
 2. When the motor is used without the hanger, plug the threaded hole with a bolt of M16 X 20 mm or less.

Model	Output [kW]	Inertia Moment $J[\times 10^{-4} \text{kg} \cdot \text{m}^2]$	Mass [kg]
HA-LFS25K1 HA-LFS25K14	25	1080	230
HA-LFS37K1M HA-LFS37K1M4	37		
HA-LFS45K24	45		

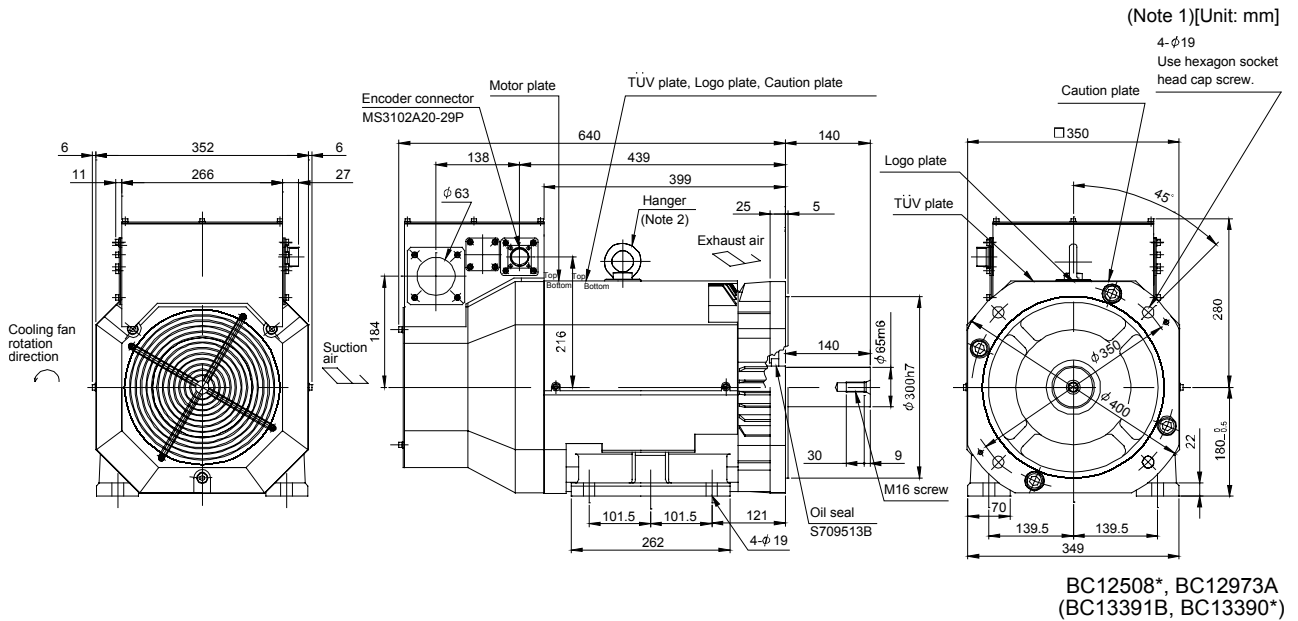

Note 1. The dimensions without tolerances are reference dimensions.
 2. When the motor is used without the hanger, plug the threaded hole with a bolt of M16 X 20 mm or less.

7. OUTLINE DIMENSION DRAWINGS

Model	Output [kW]	Inertia Moment $J[\times 10^{-4} \text{kg} \cdot \text{m}^2]$	Mass [kg]
HA-LFS30K1 HA-LFS30K14	30	1310	250
HA-LFS45K1M4	45		
HA-LFS55K24	55		

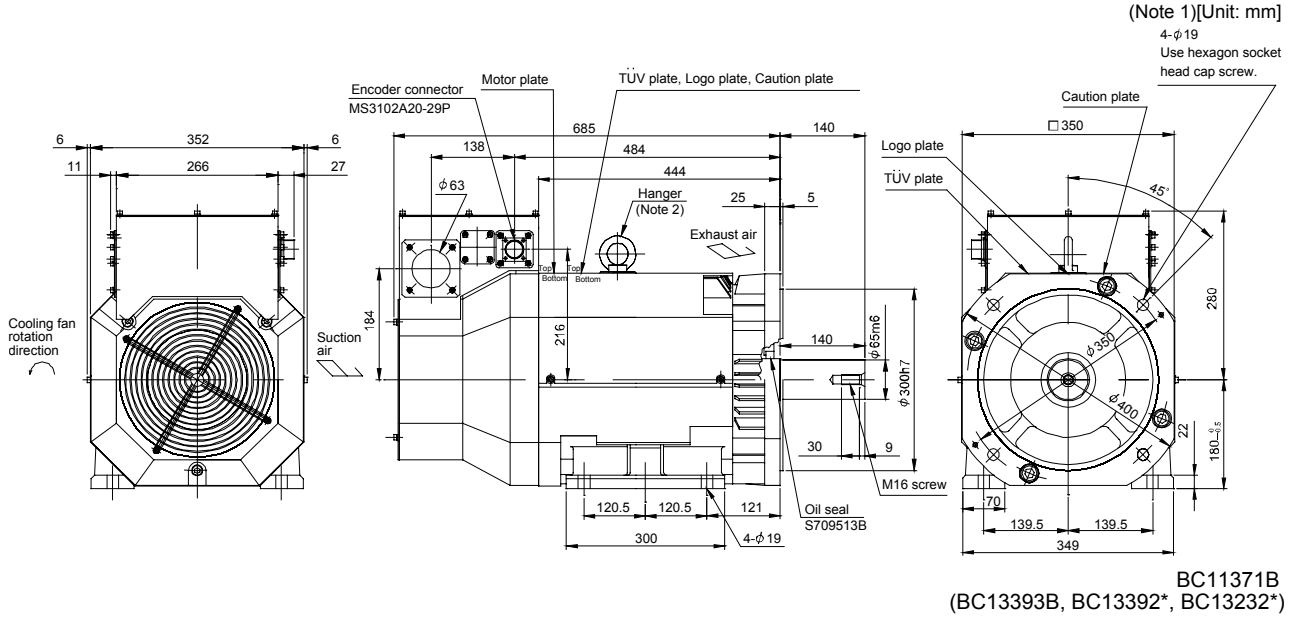

Note 1. The dimensions without tolerances are reference dimensions.

2. When the motor is used without the hanger, plug the threaded hole with a bolt of M16 X 20 mm or less.

Model	Output [kW]	Inertia Moment $J[\times 10^{-4} \text{kg} \cdot \text{m}^2]$	Mass [kg]
HA-LFS37K1 HA-LFS37K14	37	1870	335
HA-LFS50K1M4	50		

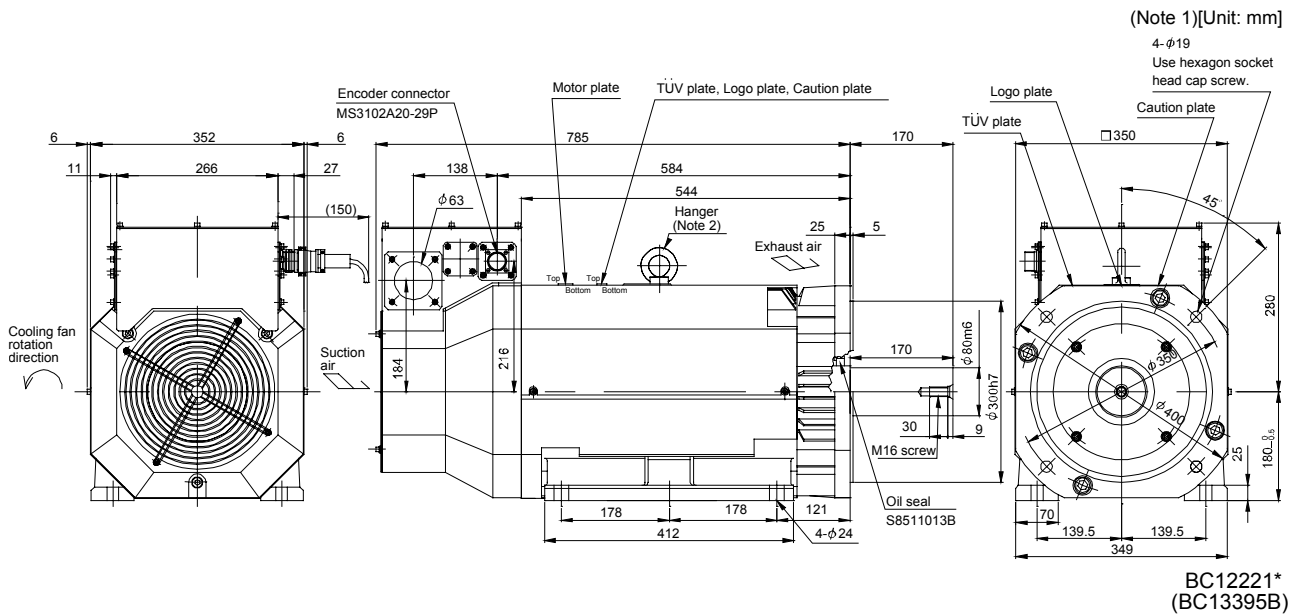

Note 1. The dimensions without tolerances are reference dimensions.

2. When the motor is used without the hanger, plug the threaded hole with a bolt of M16 X 20 mm or less.

7. OUTLINE DIMENSION DRAWINGS

Model	Output [kW]	Inertia Moment $J[\times 10^{-4} \text{kg} \cdot \text{m}^2]$	Mass [kg]
HA-LFS30K1M	30	650	180
HA-LFS37K2	37		

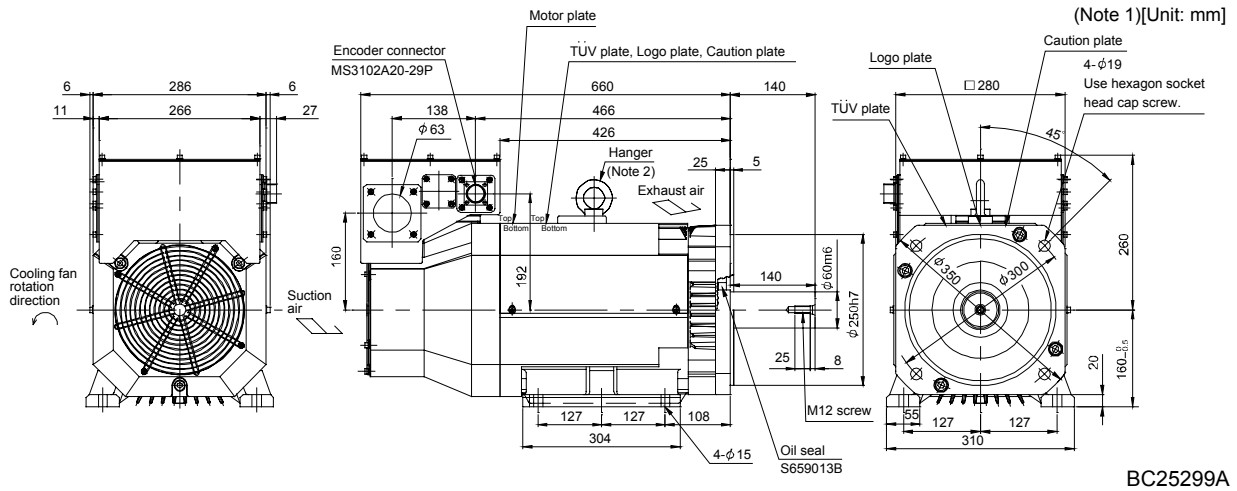

Note 1. The dimensions without tolerances are reference dimensions.
 2. When the motor is used without the hanger, plug the threaded hole with a bolt of M16 X 20 mm or less.

Model	Output [kW]	Inertia Moment $J[\times 10^{-4} \text{kg} \cdot \text{m}^2]$	Mass [kg]
HA-LFS30K2	30	550	160

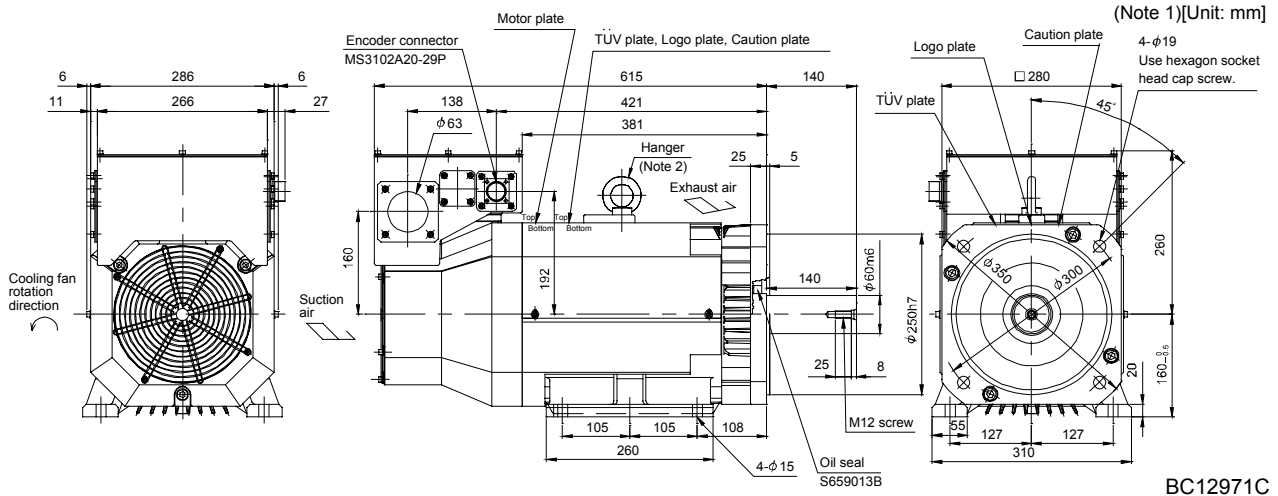

Note 1. The dimensions without tolerances are reference dimensions.
 2. When the motor is used without the hanger, plug the threaded hole with a bolt of M16 X 20 mm or less.

7. OUTLINE DIMENSION DRAWINGS

(2) With electromagnetic brake

Model	Output [kW]	Brake static friction torque [N · m]	Inertia Moment $J[\times 10^{-4} \text{ kg} \cdot \text{m}^2]$	Mass [kg]
HA-LFS601B HA-LFS6014B	6	82	113	70
HA-LFS701MB HA-LFS701M4B	7			
HA-LFS11K2B HA-LFS11K24B	11			

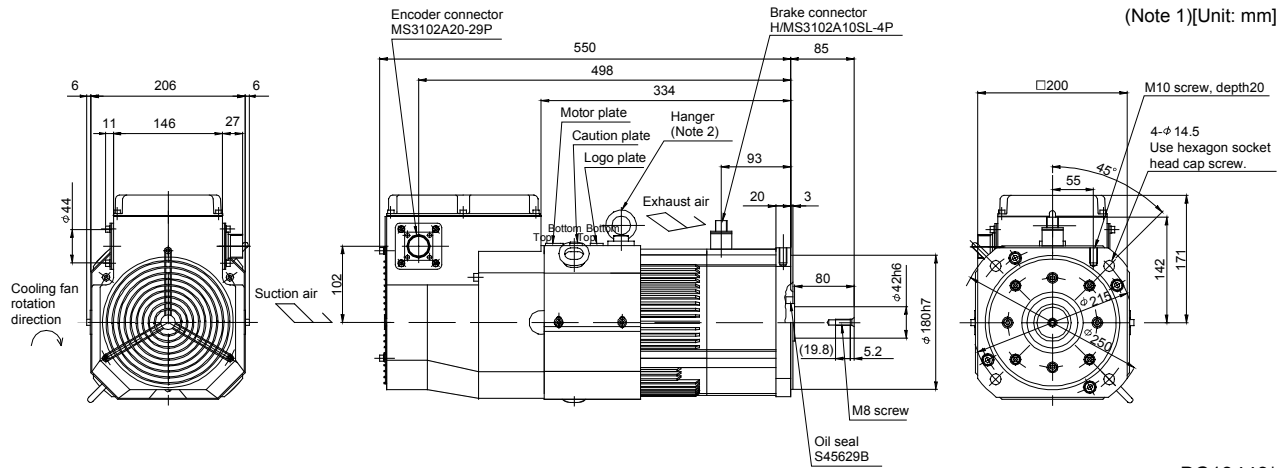

Note 1. The dimensions without tolerances are reference dimensions.
2. When the motor is used without the hanger, plug the threaded hole with a bolt of M10 × 20 mm or less.

Model	Output [kW]	Variable dimensions L	Brake static friction torque [N · m]	Inertia Moment $J[\times 10^{-4} \text{ kg} \cdot \text{m}^2]$	Mass [kg]
HA-LFS801B HA-LFS8014B	8	610	160.5	293	126.0
HA-LFS11K1MB HA-LFS11K1M4B	11				
HA-LFS15K2B HA-LFS15K24B	15	670	160.5	369	146.0
HA-LFS12K1B HA-LFS12K14B	12				
HA-LFS15K1MB HA-LFS15K1M4B	15				
HA-LFS22K2B HA-LFS22K24B	22				

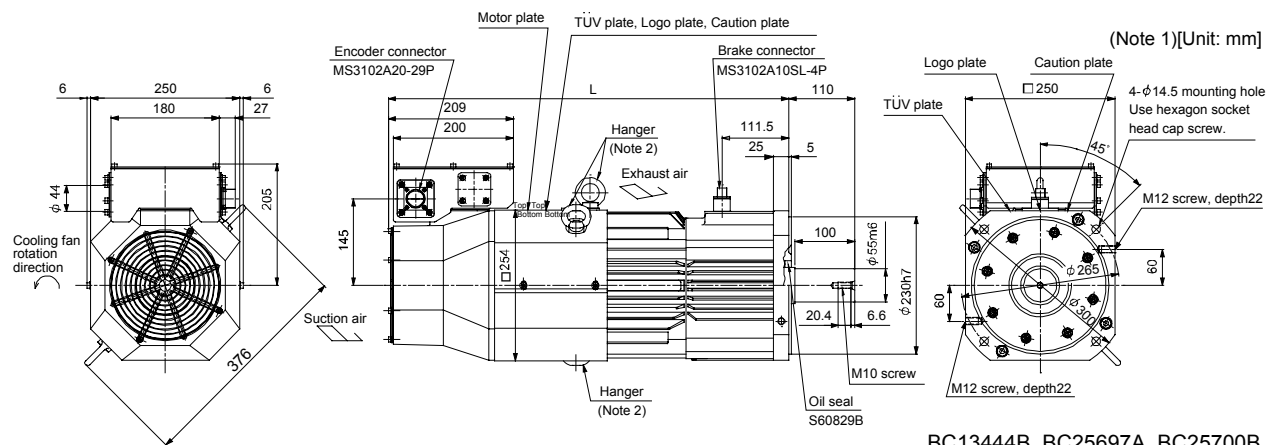

Note 1. The dimensions without tolerances are reference dimensions.
2. When the motor is used without the hanger, plug the threaded hole with a bolt of M12 × 20 mm or less.

7. OUTLINE DIMENSION DRAWINGS

7.1.14 HC-LFS series

(1) Standard (without electromagnetic brake)

Model	Output [kW]	Inertia Moment $J[\times 10^{-4} \text{ kg} \cdot \text{m}^2]$	Mass [kg]
HC-LFS52	0.5	3.2	6.5

(Note)[Unit: mm]

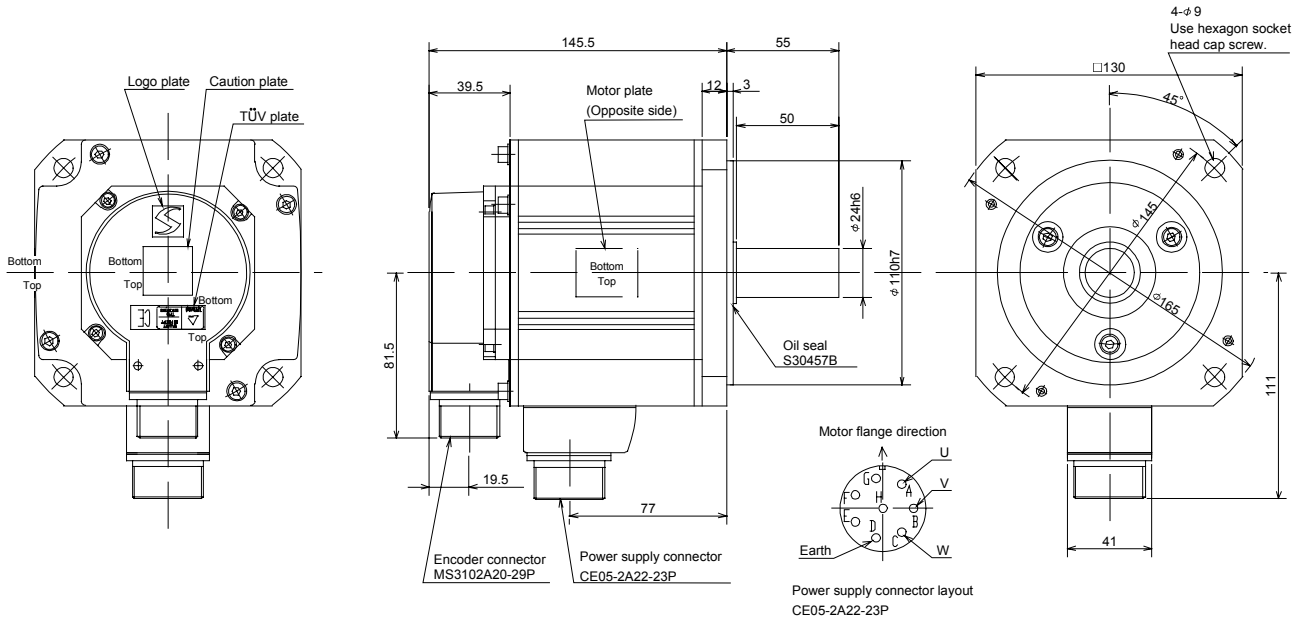

Note: The dimensions without tolerances are reference dimensions.

BC12908*

Model	Output [kW]	Inertia Moment $J[\times 10^{-4} \text{ kg} \cdot \text{m}^2]$	Mass [kg]
HC-LFS102	1.0	4.6	8

(Note)[Unit: mm]

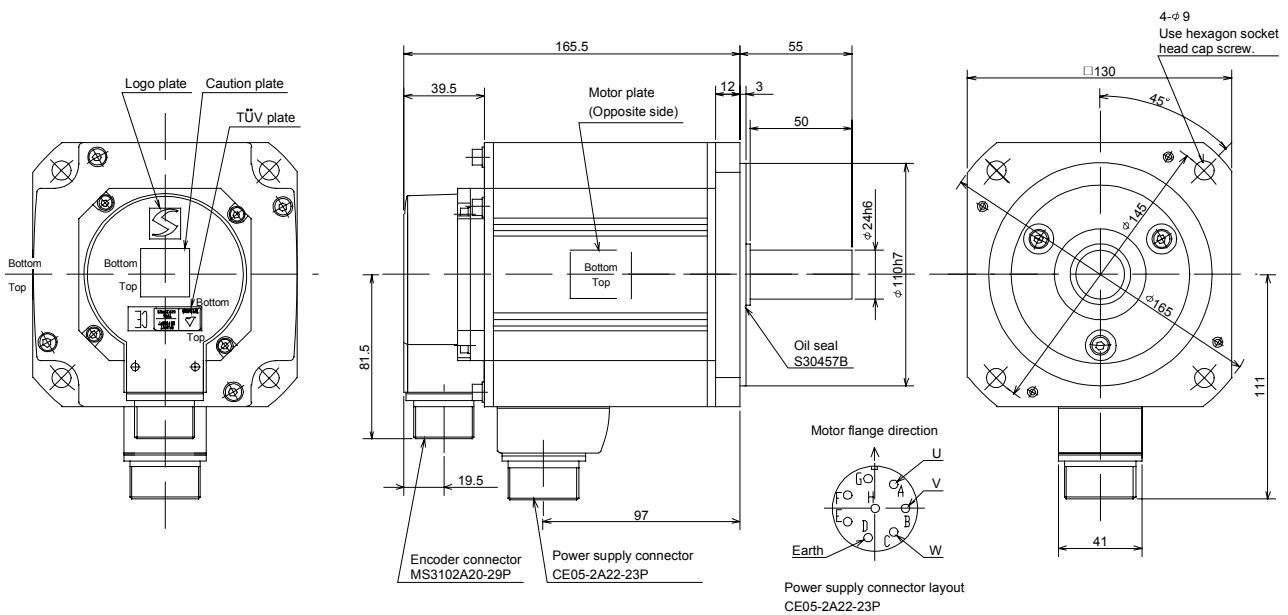

Note: The dimensions without tolerances are reference dimensions.

BC12909*

7. OUTLINE DIMENSION DRAWINGS

Model	Output [kW]	Inertia Moment $J[\times 10^{-4} \text{ kg} \cdot \text{m}^2]$	Mass [kg]
HC-LFS152	1.5	6.4	10

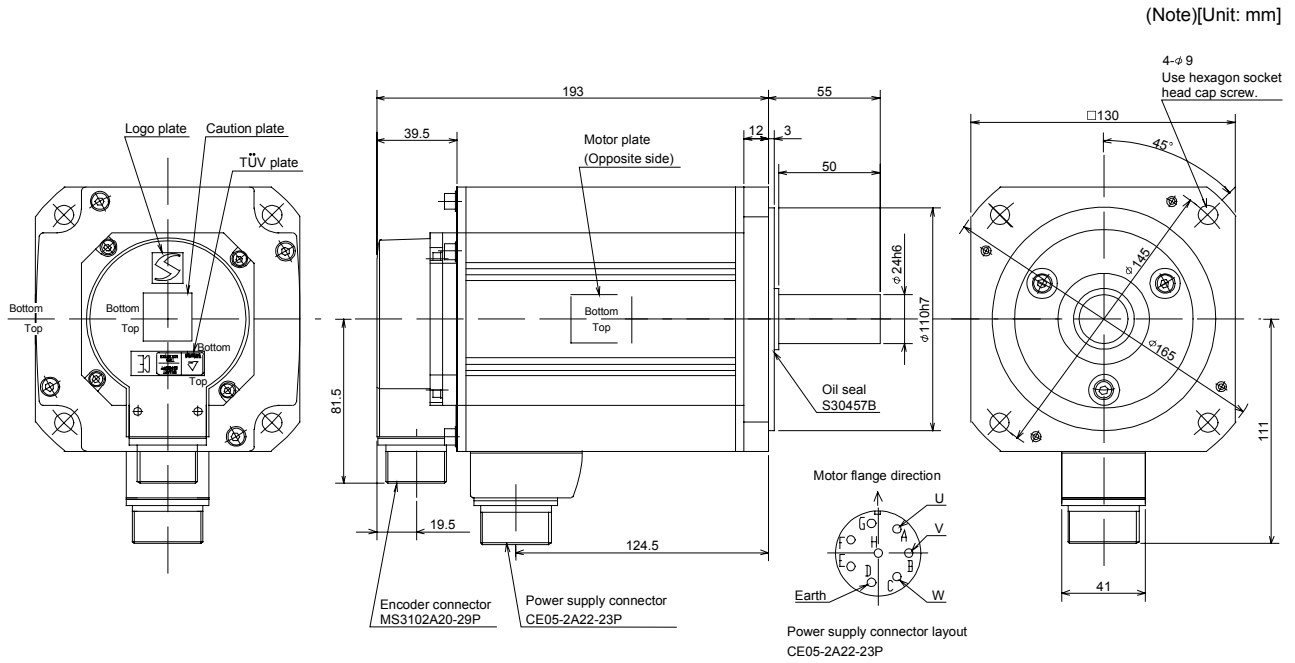

Note: The dimensions without tolerances are reference dimensions.

BC12910A

Model	Output [kW]	Inertia Moment $J[\times 10^{-4} \text{ kg} \cdot \text{m}^2]$	Mass [kg]
HC-LFS202	2.0	22	21

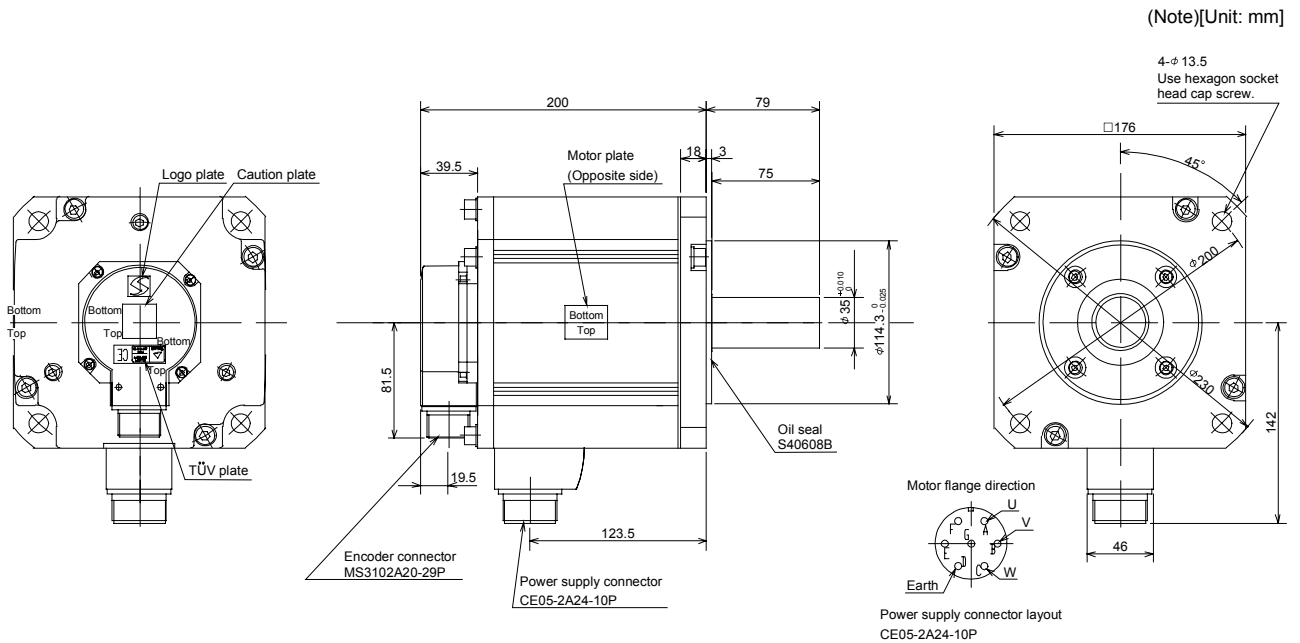

Note: The dimensions without tolerances are reference dimensions.

BC13035*

7. OUTLINE DIMENSION DRAWINGS

Model	Output [kW]	Inertia Moment $J[\times 10^{-4} \text{ kg} \cdot \text{m}^2]$	Mass [kg]
HC-LFS302	3.0	36	28

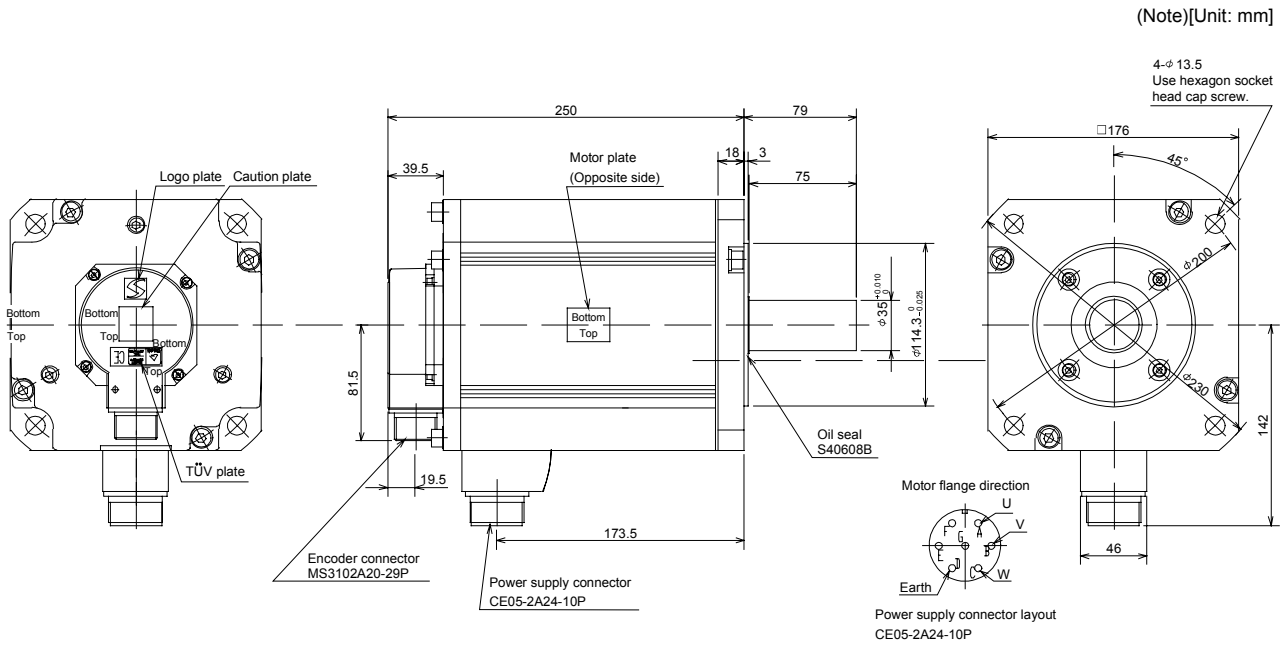

Note: The dimensions without tolerances are reference dimensions.

BC13036*

(2) With electromagnetic brake

Model	Output [kW]	Inertia Moment $J[\times 10^{-4} \text{ kg} \cdot \text{m}^2]$	Mass [kg]	Brake static friction torque [N · m]
HC-LFS52B	0.5	5.2	9	8.3

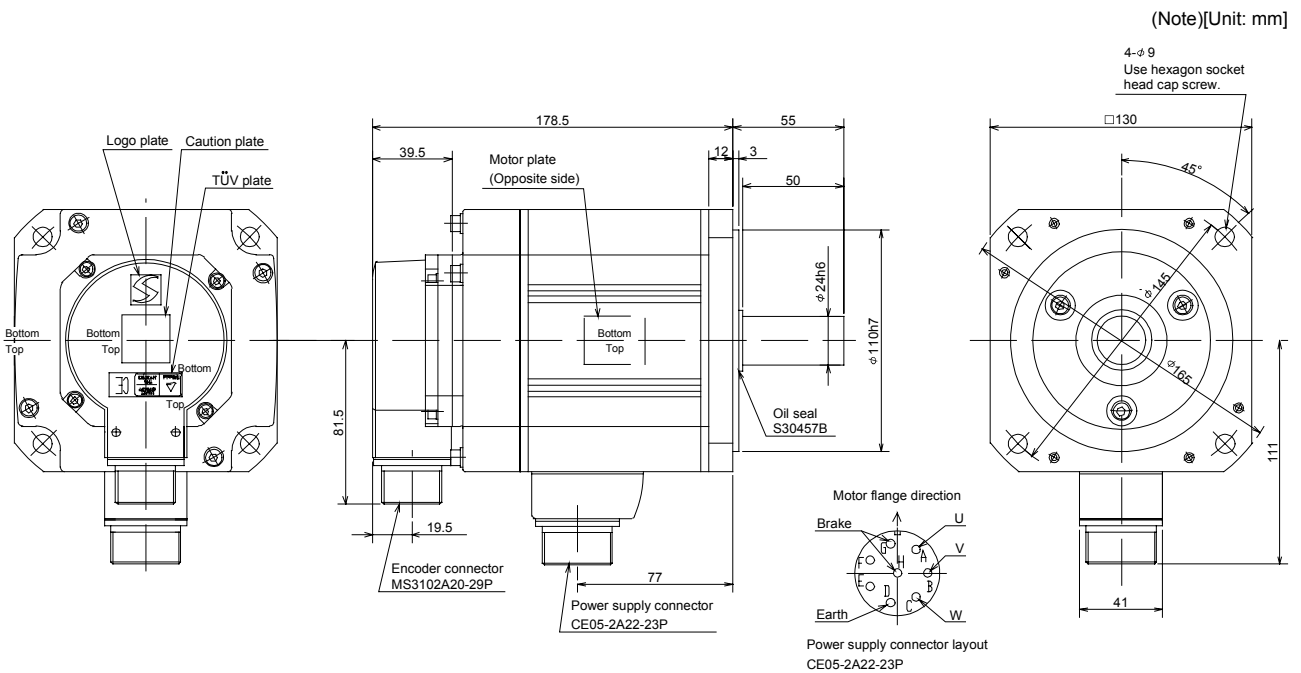

Note: The dimensions without tolerances are reference dimensions.

BC12984*

7. OUTLINE DIMENSION DRAWINGS

Model	Output [kW]	Inertia Moment J [$\times 10^{-4}$ kg · m ²]	Mass [kg]	Brake static friction torque [N · m]
HC-LFS102B	1.0	6.6	10.5	8.3

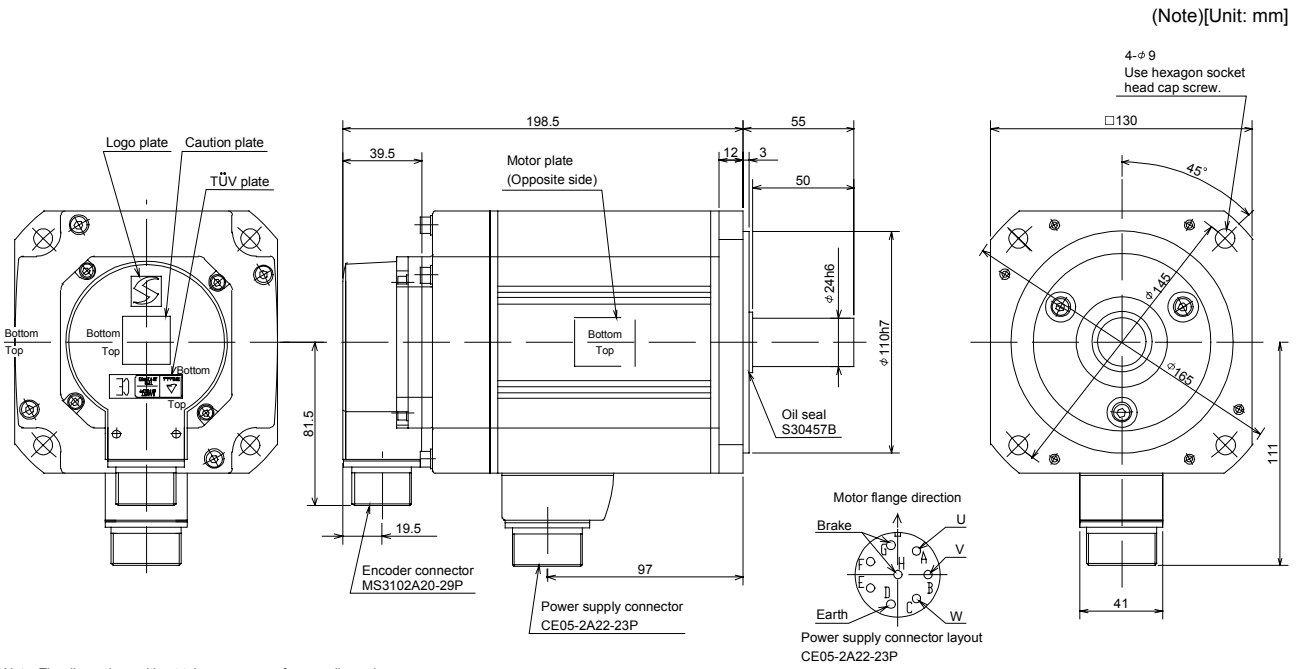

Note: The dimensions without tolerances are reference dimensions.

BC12985*

Model	Output [kW]	Inertia Moment J [$\times 10^{-4}$ kg · m ²]	Mass [kg]	Brake static friction torque [N · m]
HC-LFS152B	1.5	8.4	12.5	8.3

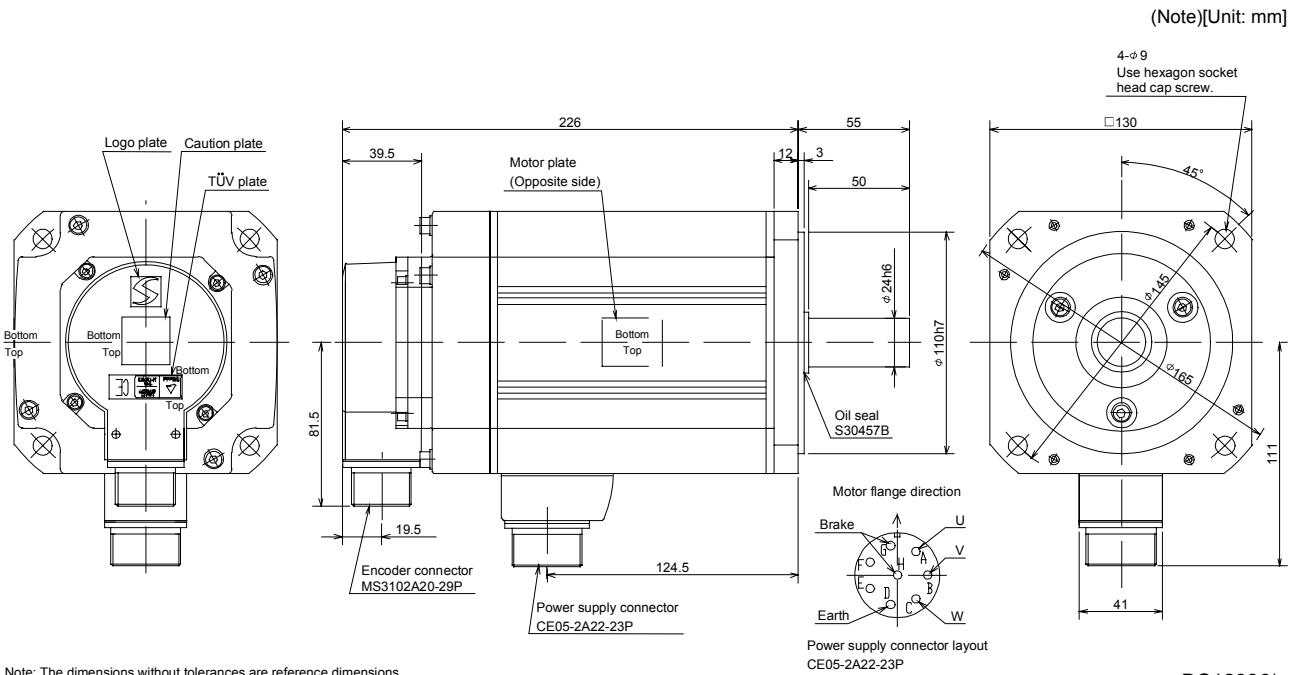

Note: The dimensions without tolerances are reference dimensions.

BC12986*

7. OUTLINE DIMENSION DRAWINGS

Model	Output [kW]	Inertia Moment $J[\times 10^{-4} \text{ kg} \cdot \text{m}^2]$	Mass [kg]	Brake static friction torque [N · m]
HC-LFS202B	2.0	32	27	43.1

(Note)[Unit: mm]

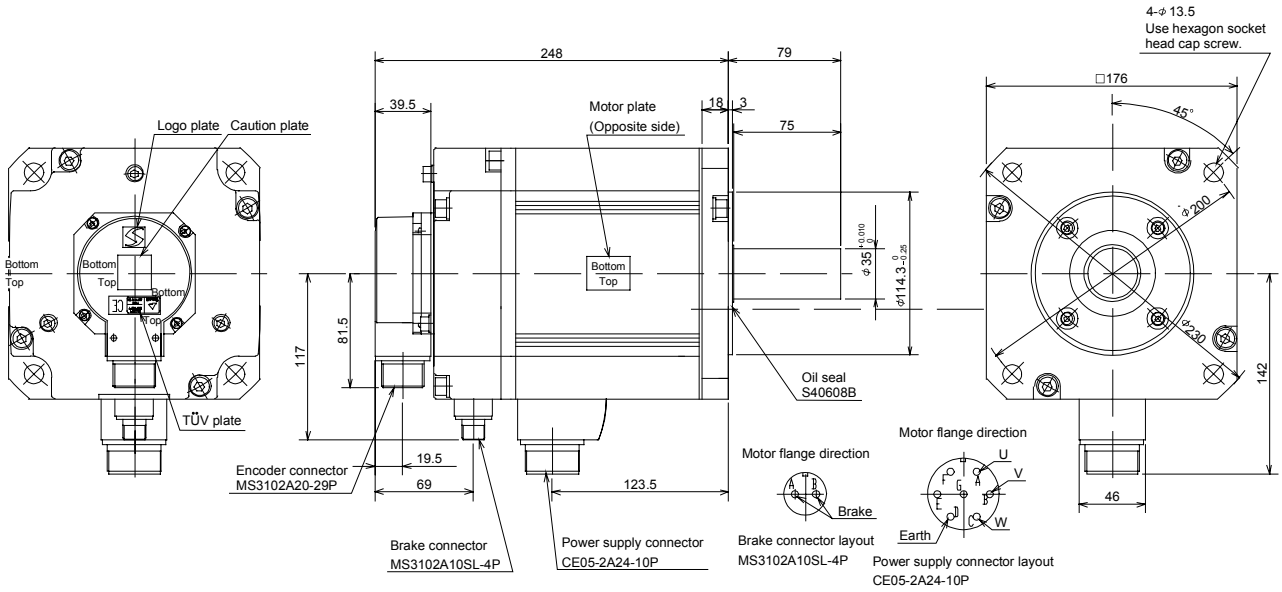

Note: The dimensions without tolerances are reference dimensions.

BC13037A

Model	Output [kW]	Inertia Moment $J[\times 10^{-4} \text{ kg} \cdot \text{m}^2]$	Mass [kg]	Brake static friction torque [N · m]
HC-LFS302B	3.0	46	34	43.1

(Note)[Unit: mm]

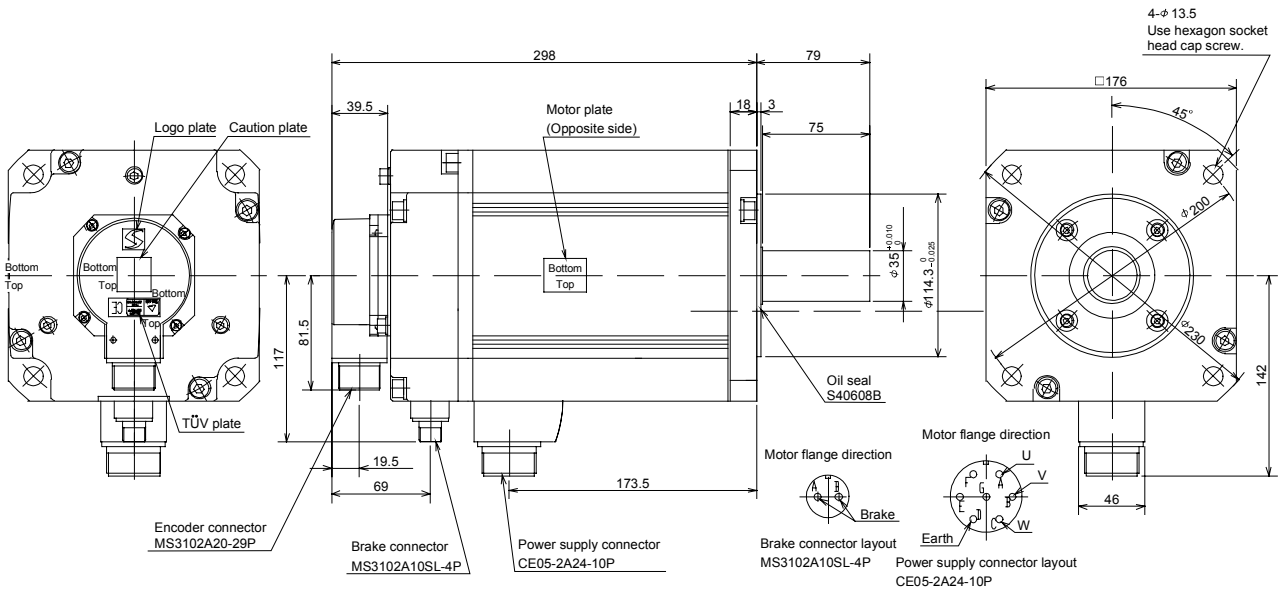

Note: The dimensions without tolerances are reference dimensions.

BC13038A

7. OUTLINE DIMENSION DRAWINGS

7.2 Servo motors (in inches)

POINT
The values in yards/pounds are reference values.

7.2.1 HC-MF • HC-KF series

(1) Standard (without electromagnetic brake, without reduction gear)

Model	Output [W]	Variable Dimensions [in]		Inertia Moment WK ² [oz • in ²]	Mass [lb]
		L	KL		
HC-MF053	50	3.21	1.16	0.10	0.9
HC-MF13	100	3.80	0.18	0.16	1.2
HC-KF053	50	3.21	0.12	0.29	0.9
HC-KF13	100	3.80	1.75	0.46	1.2

[Unit: in]

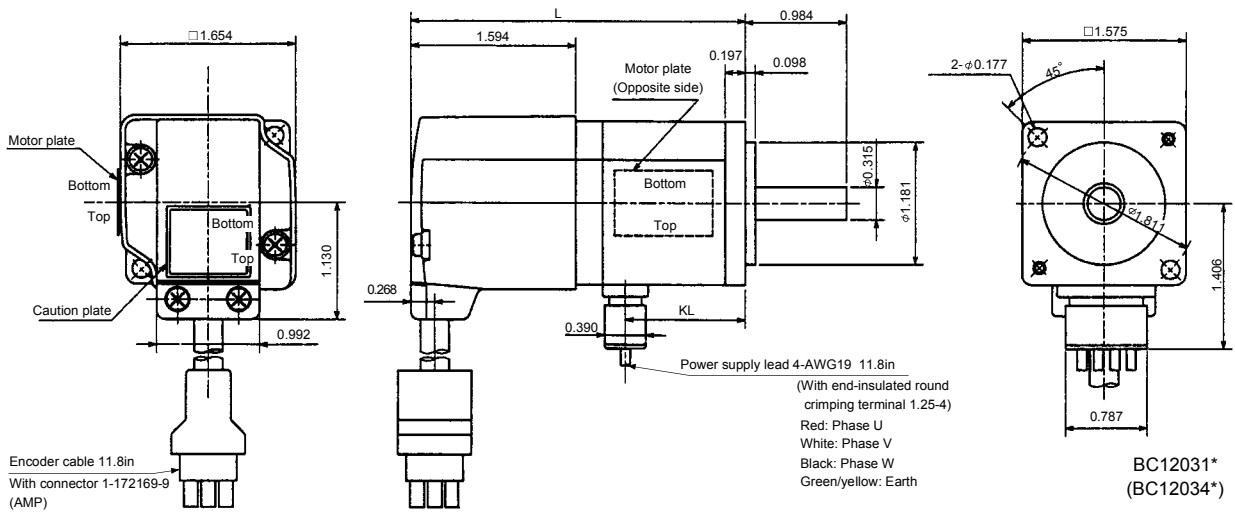

Model	Output [W]	Variable Dimensions [in]		Inertia Moment WK ² [oz • in ²]	Mass [lb]
		L	KL		
HC-MF23	200	3.92	1.93	0.48	2.2
HC-MF43	400	4.90	0.06	0.78	3.2
HC-KF23	200	3.92	1.93	1.422	2.2
HC-KF43	400	4.90	0.06	2.515	3.2

[Unit: in]

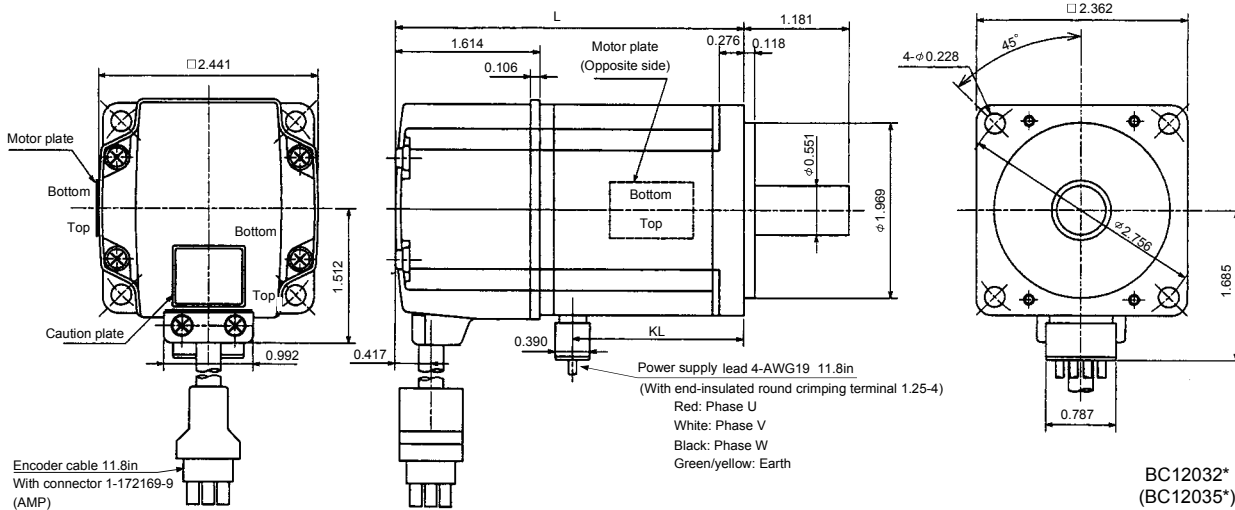

7. OUTLINE DIMENSION DRAWINGS

Model	Output [W]	Inertia Moment WK^2 [oz · in ²]	Mass [lb]
HC-MF73	750	3.28	6.6

[Unit: in]

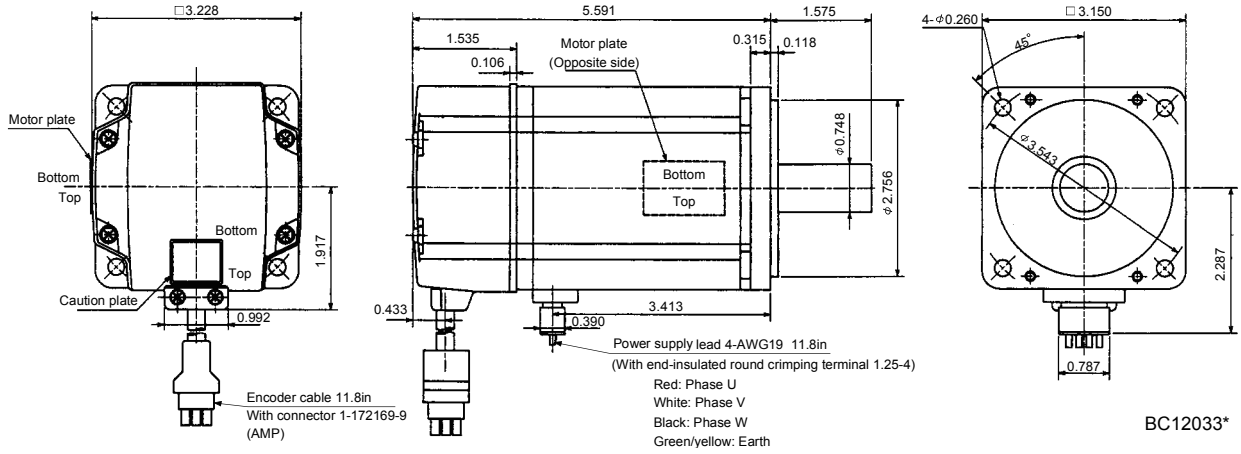

(2) With electromagnetic brake

Model	Output [W]	Variable Dimensions [in]		Brake static friction torque [oz · in]	Inertia Moment WK^2 [oz · in ²]	Mass [lb]
		L	KL			
HC-MF053B	50	4.31	1.16	45.32	0.12	1.7
HC-MF13B	100	4.90	1.75	45.32	0.18	2.0
HC-KF053B	50	4.31	1.16	45.32	0.31	1.7
HC-KF13B	100	4.90	1.75	45.32	0.48	2.0

[Unit: in]

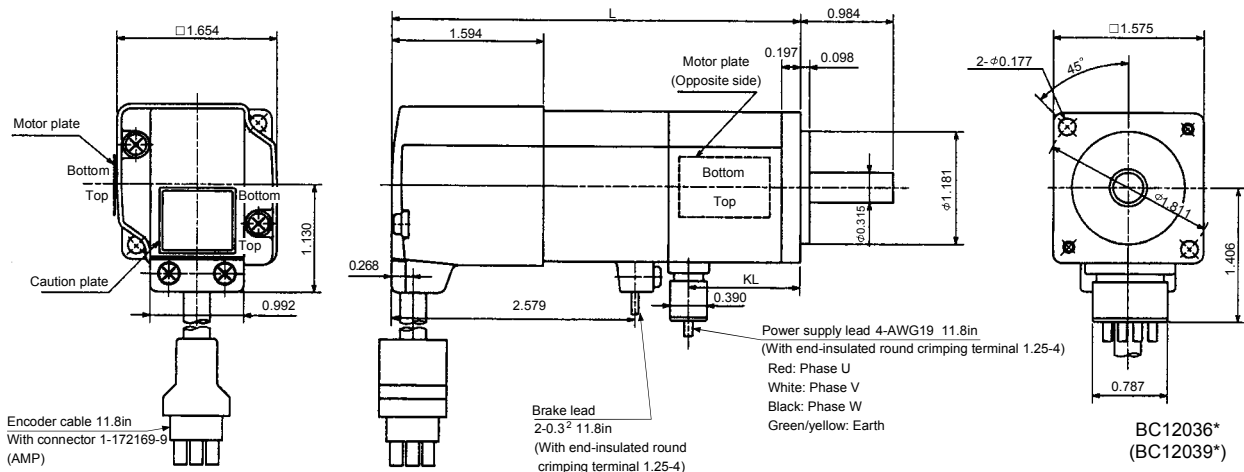

7. OUTLINE DIMENSION DRAWINGS

Model	Output [W]	Variable Dimensions [in]		Brake static friction torque [oz · in]	Inertia Moment WK^2 [oz · in ²]	Mass [lb]
		L	KL			
HC-MF23B	200	5.18	1.93	184	0.74	3.5
HC-MF43B	400	6.16	2.84	184	1.04	4.6
HC-KF23B	200	5.18	1.93	184	1.694	3.5
HC-KF43B	400	6.16	2.84	184	2.788	4.6

[Unit: in]

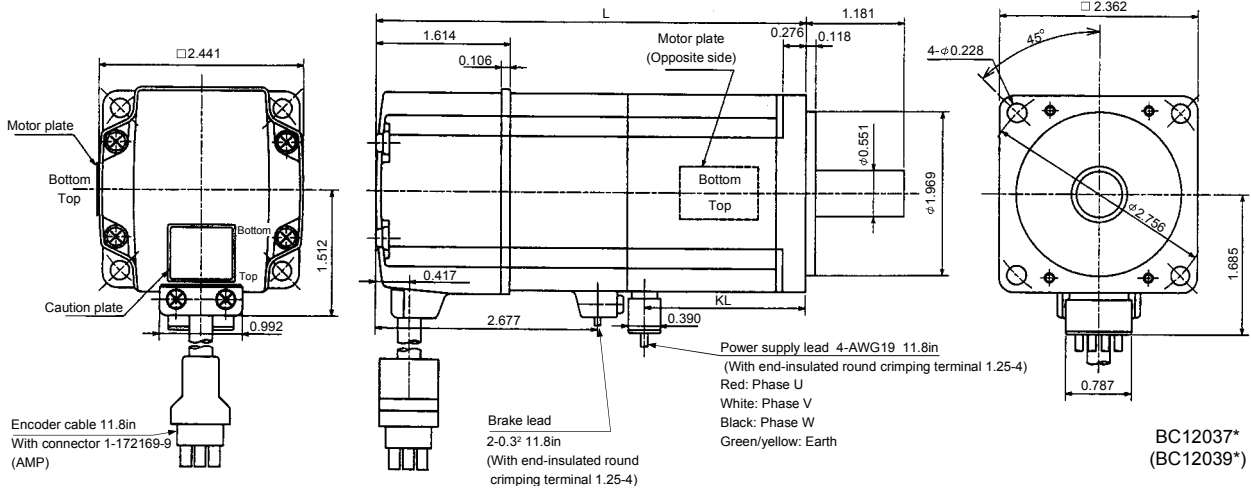

Model	Output [W]	Brake static friction torque [oz · in]	Inertia Moment WK^2 [oz · in ²]	Mass [lb]
HC-MF73B	750	340	3.96	8.8

[Unit: in]

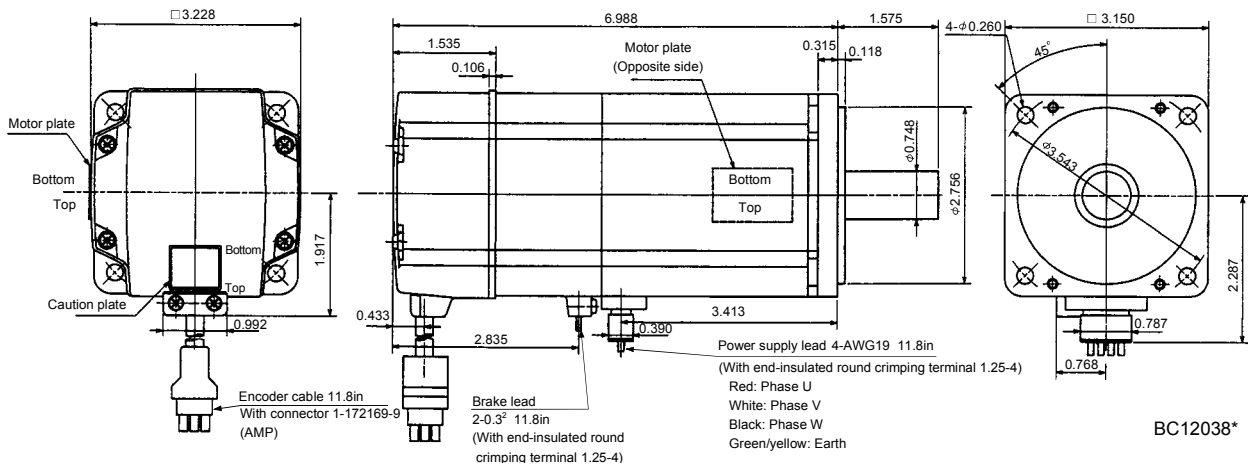

7. OUTLINE DIMENSION DRAWINGS

(3) With reduction gear for general industrial machine

The outer frame of the reduction gear is a material surface such as casting. Its actual dimensions may be 0.039 to 0.118 in larger than the drawing dimensions. Design the machine side with allowances.

(a) Without electromagnetic brake

Model	Output [W]	Variable Dimensions [in]		Reduction Gear Model	Reduction Ratio (Actual Reduction Ratio)	Inertia Moment WK^2 [oz · in ²]	Backlash	Mass [lb]
		L	KL					
HC-MF053G1	50	4.96	2.91	K6505	1/5(9/44)	0.30	60min. max.	3.1
HC-MF053G1	50	5.669	3.62	K6512	1/12(49/576)	0.42	60min. max.	4.0
HC-MF053G1	50	5.669	3.62	K6520	1/20(25/484)	0.32	60min. max.	4.0
HC-KF053G1	50	4.96	2.91	K6505	1/5(9/44)	0.49	60min. max.	3.1
HC-KF053G1	50	5.669	3.62	K6512	1/12(49/576)	0.61	60min. max.	4.0
HC-KF053G1	50	5.669	3.62	K6520	1/20(25/484)	0.51	60min. max.	4.0

[Unit: in]

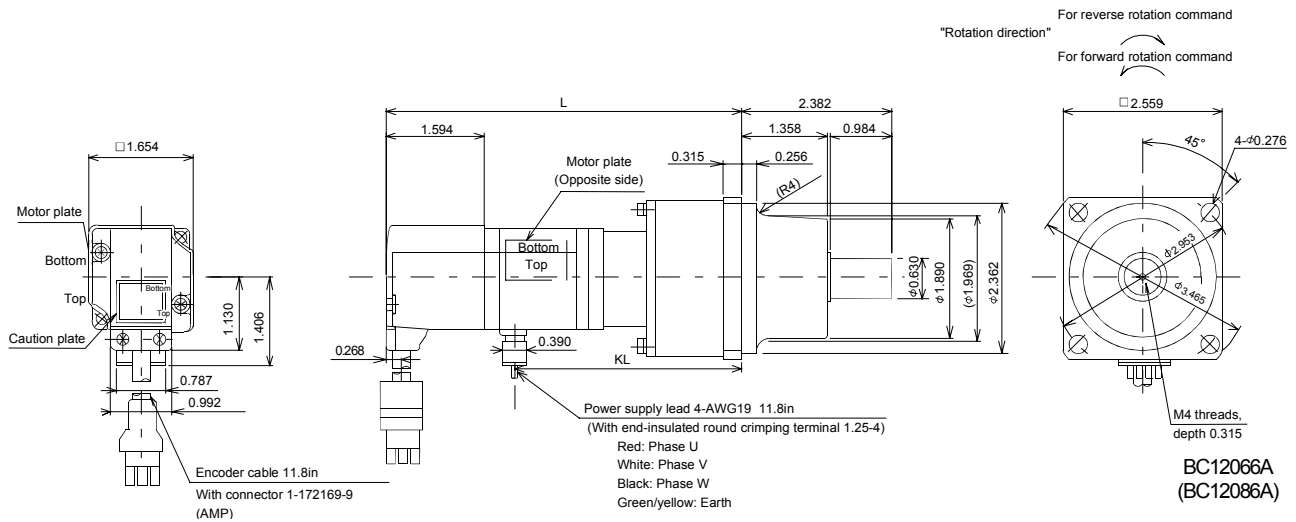

Model	Output [W]	Variable Dimensions [in]		Reduction Gear Model	Reduction Ratio (Actual Reduction Ratio)	Inertia Moment WK^2 [oz · in ²]	Backlash	Mass [lb]
		L	KL					
HC-MF13G1	100	5.551	3.5	K6505	1/5(9/44)	0.36	60min. max.	3.3
HC-MF13G1	100	6.26	4.21	K6512	1/12(49/576)	0.48	60min. max.	4.2
HC-MF13G1	100	6.26	4.21	K6520	1/20(25/484)	0.38	60min. max.	4.2
HC-KF13G1	100	5.551	3.5	K6505	1/5(9/44)	0.66	60min. max.	3.3
HC-KF13G1	100	6.26	4.21	K6512	1/12(49/576)	0.78	60min. max.	4.2
HC-KF13G1	100	6.26	4.21	K6520	1/20(25/484)	0.68	60min. max.	4.2

[Unit: in]

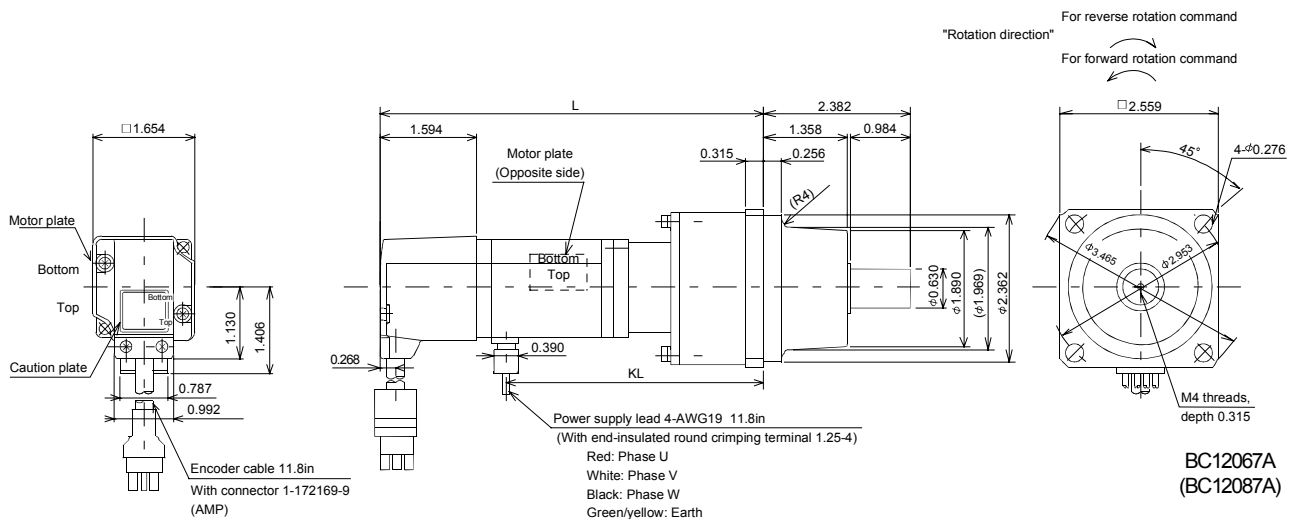

7. OUTLINE DIMENSION DRAWINGS

Model	Output [W]	Variable Dimensions [in]		Reduction Gear Model	Reduction Ratio (Actual Reduction Ratio)	Inertia Moment WK^2 [oz · in ²]	Mass [lb]
		L	KL				
HC-MF23G1	200	6.02	4.04	K9005	1/5(19/96)	1.36	7.3
HC-MF23G1	200	6.81	4.83	K9012	1/12(25/288)	1.60	8.6
HC-MF23G1	200	6.81	4.83	K9020	1/20(253/5000)	1.45	8.6
HC-KF23G1	200	6.02	4.04	K9005	1/5(19/96)	2.296	7.3
HC-KF23G1	200	6.81	4.83	K9012	1/12(25/288)	2.569	8.6
HC-KF23G1	200	6.81	4.83	K9020	1/20(253/5000)	2.406	8.6

[Unit: in]

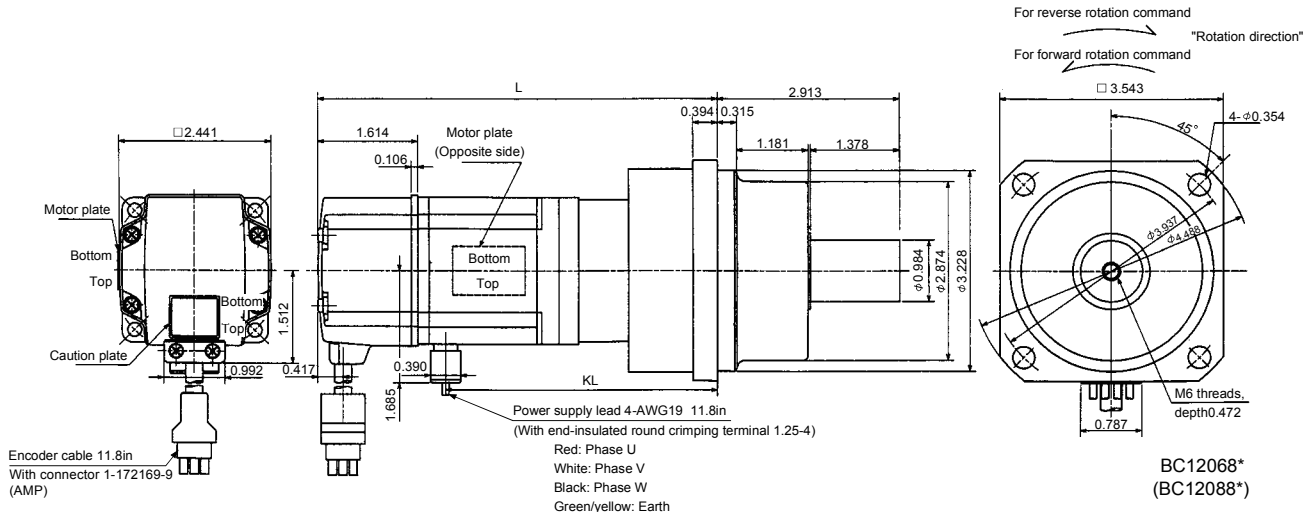

Model	Output [W]	Variable Dimensions [in]		Reduction Gear Model	Reduction Ratio (Actual Reduction Ratio)	Inertia Moment WK^2 [oz · in ²]	Mass [lb]
		L	KL				
HC-MF43G1	400	7.01	4.95	K9005	1/5(19/96)	1.62	8.4
HC-MF43G1	400	7.80	5.73	K9012	1/12(25/288)	1.85	9.7
HC-KF43G1	400	7.01	4.95	K9005	1/5(19/96)	3.335	8.4
HC-KF43G1	400	7.80	5.73	K9012	1/12(25/288)	3.609	9.7

[Unit: in]

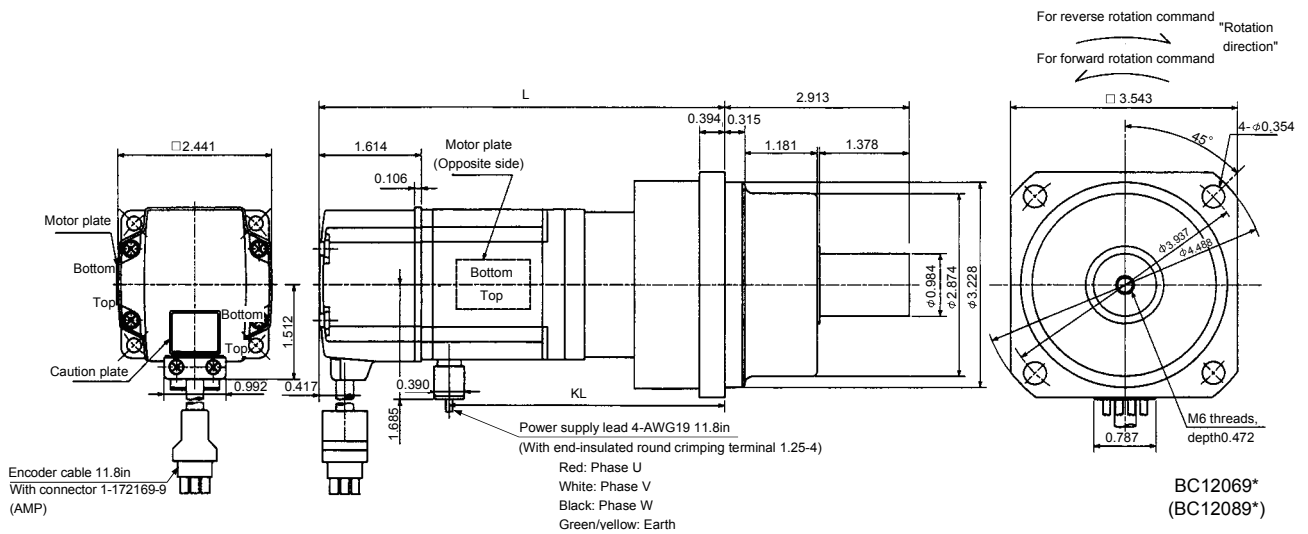

7. OUTLINE DIMENSION DRAWINGS

Model	Output [W]	Reduction Gear Model	Reduction Ratio		Inertia Moment WK ² [oz · in ²]	Backlash	Mass [lb]
			Normal Reduction ratio	Actual Reduction Ratio			
HC-MF43G1	400	K10020	1/20	253/5000	3.57	60min. max.	12.13
HC-MF73G1	750	K10005	1/5	1/5	5.58	60min. max.	13.67
HC-MF73G1	750	K10012	1/12	525/6048	9.22	60min. max.	16.09
HC-MF73G1	750	K12020	1/20	625/12544	9.57	60min. max.	22.27

Model	Output [W]	Variable Dimensions [in]																						
		D	LH	LK	LT	H	LA	LB	LC	LD	LE	LF	LG	LM	LN	LP	L	LR	KL	LZ	Q	S	P	R
HC-MF43G1	400	2.362	1.50	1.61	0.42	1.69	4.53	3.74	5.20	3.94	0.39	2.87	0.39	0.512	0.63	3.39	7.933	3.54	5.87	0.35	1.97	1.26	M8	0.63
HC-MF73G1	750	3.15	1.89	1.54	0.43	2.29	4.53	3.74	5.20	3.94	0.39	2.87	0.39	0.512	0.63	3.39	8.15	3.54	5.97	0.35	1.97	1.26	M8	0.63
HC-MF73G1	750	3.15	1.89	1.54	0.43	2.29	4.53	3.74	5.20	3.94	0.39	2.87	0.39	0.512	0.63	3.39	9.016	3.54	6.84	0.35	1.97	1.26	M8	0.63
HC-MF73G1	750	3.15	1.89	1.54	0.43	2.29	5.51	4.53	6.38	4.72	0.47	3.54	0.59	0.512	0.787	4.09	9.528	4.17	7.35	0.55	2.36	1.57	M10	0.79

[Unit: in]

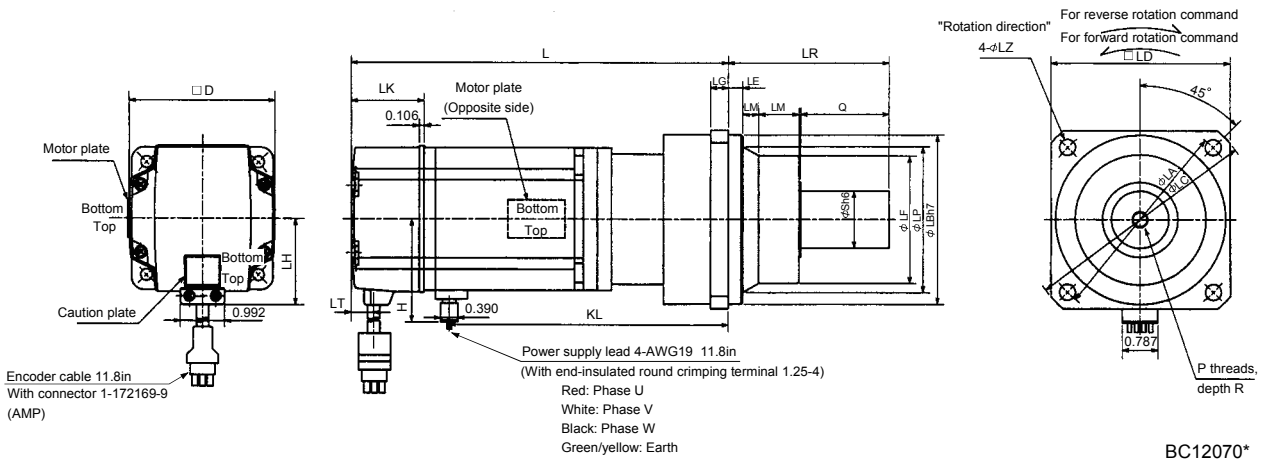

Model	Output [W]	Reduction Gear Model	Reduction Ratio		Inertia Moment WK ² [oz · in ²]	Backlash	Mass [lb]
			Normal Reduction ratio	Actual Reduction Ratio			
HC-KF43G1	400	K10020	1/20	253/5000	5.303	60min. max.	12.13

[Unit: in]

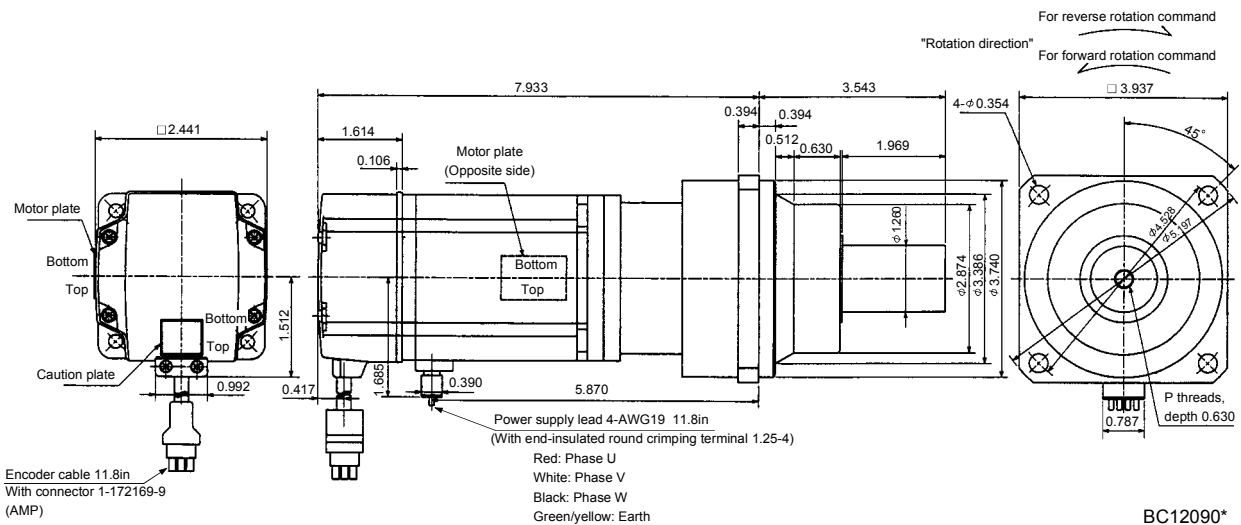

7. OUTLINE DIMENSION DRAWINGS

(b) With electromagnetic brake

Model	Output [W]	Variable Dimensions [in]		Brake static friction torque [oz · in]	Reduction Gear Model	Reduction Ratio (Actual Reduction Ratio)	Inertia Moment WK ² [oz · in ²]	Backlash	Mass [lb]
		L	KL						
HC-MF053BG1	50	6.06	2.91	45	K6505	1/5(9/44)	0.32	60min. max.	4.0
HC-MF053BG1	50	6.77	3.62	45	K6512	1/12(49/576)	0.44	60min. max.	4.9
HC-MF053BG1	50	6.77	3.62	45	K6520	1/20(25/484)	0.34	60min. max.	4.9
HC-KF053BG1	50	6.02	2.91	45	K6505	1/5(9/44)	0.51	60min. max.	4.0
HC-KF053BG1	50	6.77	3.62	45	K6512	1/12(49/576)	0.63	60min. max.	4.9
HC-KF053BG1	50	6.77	3.62	45	K6520	1/20(25/484)	0.53	60min. max.	4.9

[Unit: in]

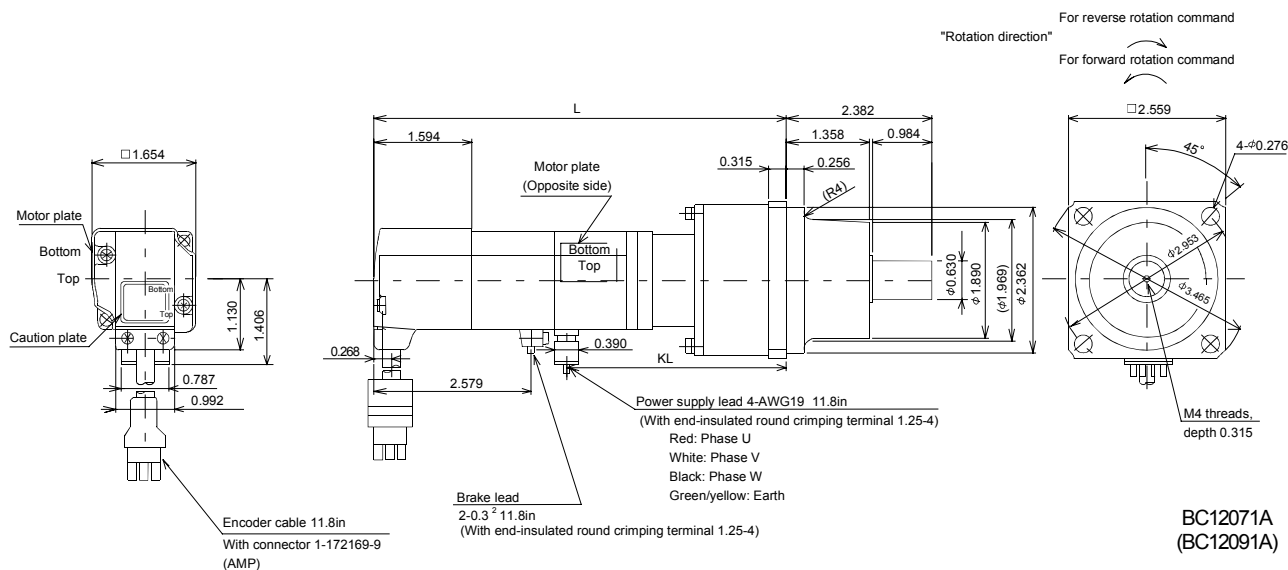

Model	Output [W]	Variable Dimensions [in]		Brake static friction torque [oz · in]	Reduction Gear Model	Reduction Ratio (Actual Reduction Ratio)	Inertia Moment WK ² [oz · in ²]	Backlash	Mass [lb]
		L	KL						
HC-MF13BG1	100	6.65	3.43	45	K6505	1/5(9/44)	0.38	60min. max.	4.2
HC-MF13BG1	100	7.36	4.21	45	K6512	1/12(49/576)	0.50	60min. max.	5.1
HC-MF13BG1	100	7.36	4.21	45	K6520	1/20(25/484)	0.40	60min. max.	5.1
HC-KF13BG1	100	6.65	3.43	45	K6505	1/5(9/44)	0.68	60min. max.	4.2
HC-KF13BG1	100	7.36	4.21	45	K6512	1/12(49/576)	0.80	60min. max.	5.1
HC-KF13BG1	100	7.36	4.21	45	K6520	1/20(25/484)	0.7	60min. max.	5.1

[Unit: in]

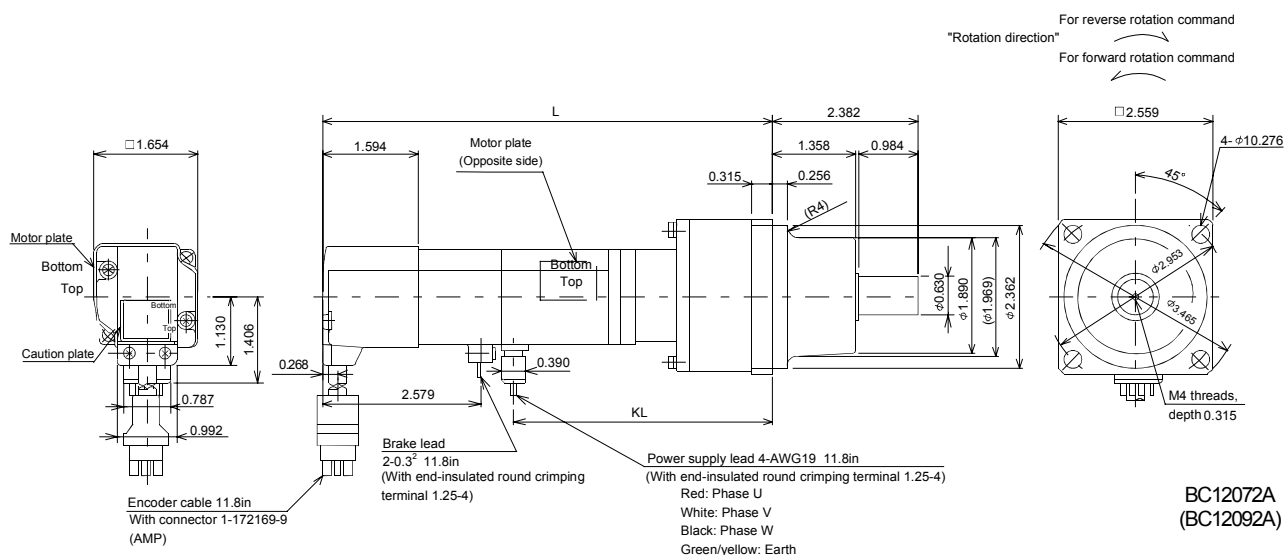

7. OUTLINE DIMENSION DRAWINGS

Model	Output [W]	Variable Dimensions [in]		Reduction Gear Model	Reduction Ratio (Actual Reduction Ratio)	Inertia Moment WK ² [oz · in ²]	Mass [lb]	Brake static friction torque [oz · in]
		L	KL					
HC-MF23BG1	200	6.65	4.04	K9005	1/5(19/96)	1.58	8.6	184
HC-MF23BG1	200	7.36	4.23	K9012	1/12(25/288)	1.82	9.9	184
HC-MF23BG1	200	7.36	4.23	K9020	1/20(253/5000)	1.67	9.9	184
HC-KF23BG1	200	6.65	4.04	K9005	1/5(19/96)	2.569	8.6	184
HC-KF23BG1	200	7.36	4.23	K9012	1/12(25/288)	2.843	9.9	184
HC-KF23BG1	200	7.36	4.23	K9020	1/20(253/5000)	2.679	9.9	184

[Unit: in]

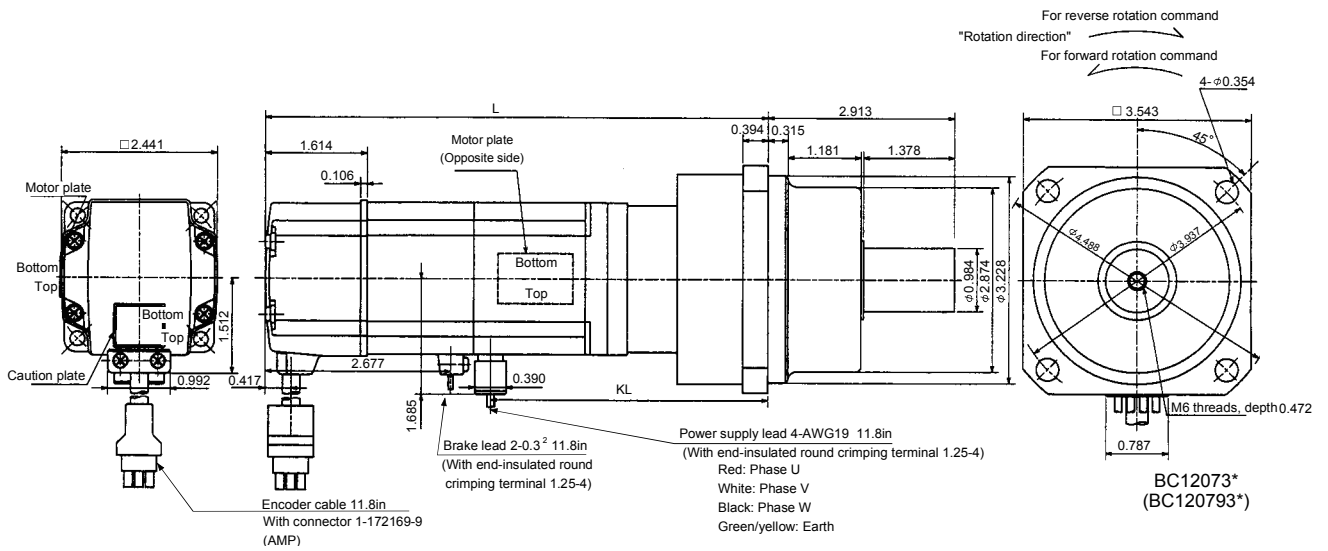

Model	Output [W]	Variable Dimensions [in]		Brake static friction torque [oz · in]	Reduction Gear Model	Reduction Ratio (Actual Reduction Ratio)	Inertia Moment WK ² [oz · in ²]	Mass [lb]
		L	KL					
HC-MF43BG1	400	8.27	4.95	184	K9005	1/5(19/96)	1.88	9.7
HC-MF43BG1	400	9.06	5.73	184	K9012	1/12(25/288)	2.12	11.0
HC-KF43BG1	400	8.27	4.95	184	K9005	1/5(19/96)	3.609	9.7
HC-KF43BG1	400	9.06	5.73	184	K9012	1/12(25/288)	3.882	11.0

[Unit: in]

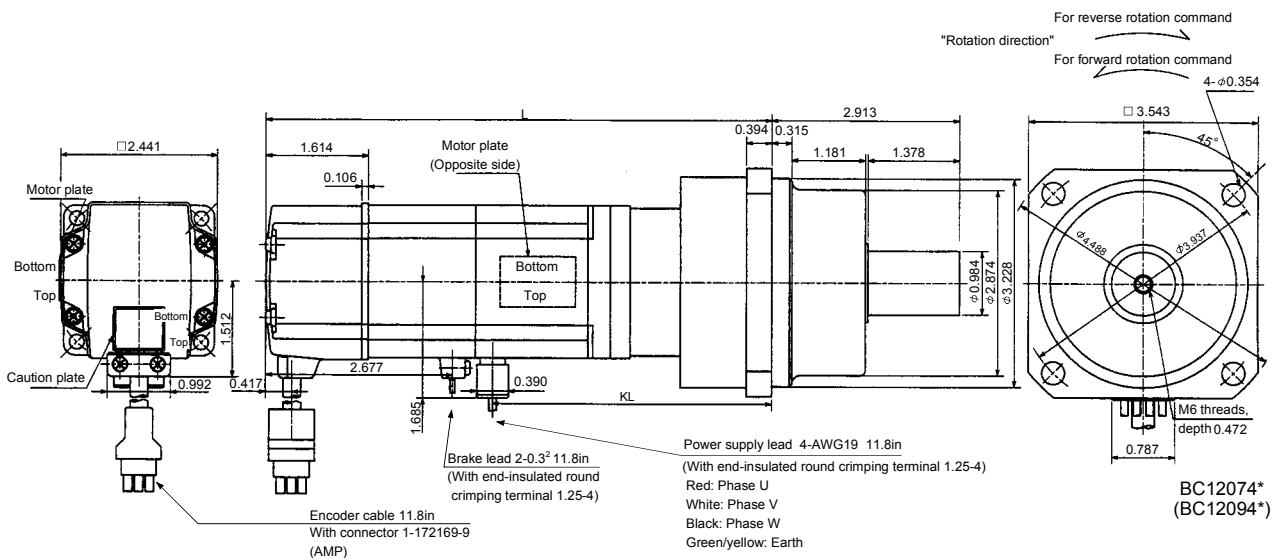

7. OUTLINE DIMENSION DRAWINGS

Model	Output [W]	Brake static friction torque [oz · in]	Reduction Gear Model	Reduction Ratio		Inertia Moment WK ² [oz · in ²]	Backlash	Mass [lb]
				Normal Reduction ratio	Actual Reduction Ratio			
HC-MF43BG1	400	184	K10020	1/20	253/5000	3.83	60min. max.	13.4
HC-MF73BG1	750	340	K10005	1/5	1/5	6.26	60min. max.	15.9
HC-MF73BG1	750	340	K10012	1/12	525/6048	9.90	60min. max.	18.3
HC-MF73BG1	750	340	K12020	1/20	625/12544	10.25	60min. max.	25.8

Model	Output [W]	Variable Dimensions [in]																							
		D	LH	LK	LT	LX	H	LA	LB	LC	LD	LE	LF	LG	LM	LN	LP	L	LR	KL	LZ	Q	S	P	R
HC-MF43BG1	400	2.44	1.51	1.64	0.14	2.68	1.69	4.53	3.74	5.20	3.94	0.39	2.87	0.39	0.512	0.63	3.39	9.19	3.54	5.87	0.35	1.97	1.26	M8	0.63
HC-MF73BG1	750	3.23	1.92	1.54	0.43	2.84	1.69	4.53	3.74	5.20	3.94	0.39	2.87	0.39	0.512	0.63	3.39	9.55	3.54	5.92	0.35	1.97	1.26	M8	0.63
HC-MF73BG1	750	3.23	1.92	1.54	0.43	2.84	1.69	4.53	3.74	5.20	3.94	0.39	2.87	0.39	0.512	0.63	3.39	10.41	3.54	6.84	0.35	1.97	1.26	M8	0.63
HC-MF73BG1	750	3.23	1.92	1.54	0.43	2.84	1.69	5.51	4.53	6.38	4.72	0.47	3.54	0.59	0.512	0.787	4.09	10.93	4.17	7.35	0.55	2.36	1.57	M10	0.79

[Unit: in]

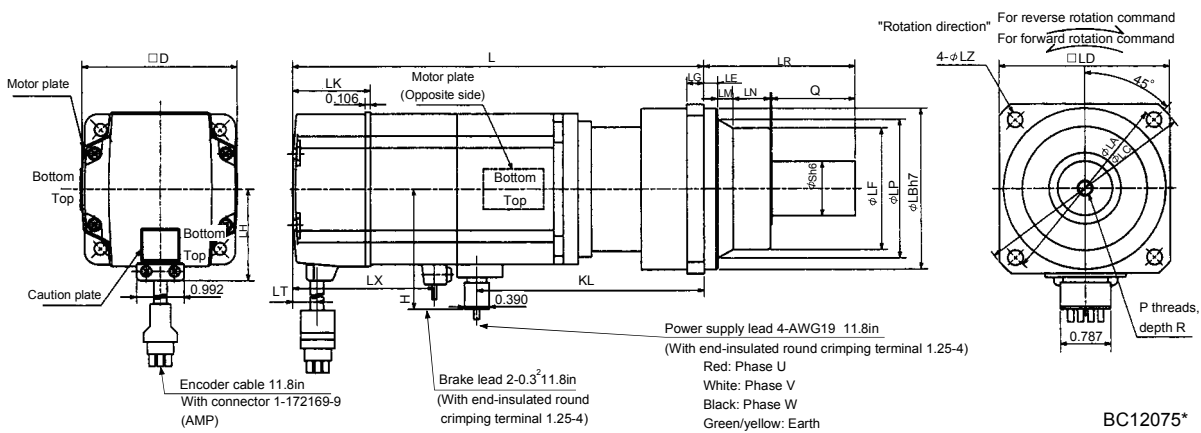

Model	Output [W]	Brake static friction torque [oz · in]	Reduction Gear Model	Reduction Ratio		Inertia Moment WK ² [oz · in ²]	Backlash	Mass [lb]
				Normal Reduction ratio	Actual Reduction Ratio			
HC-KF43BG1	400	184	K10020	1/20	253/5000	5.577	60min. max.	13.4

[Unit: in]

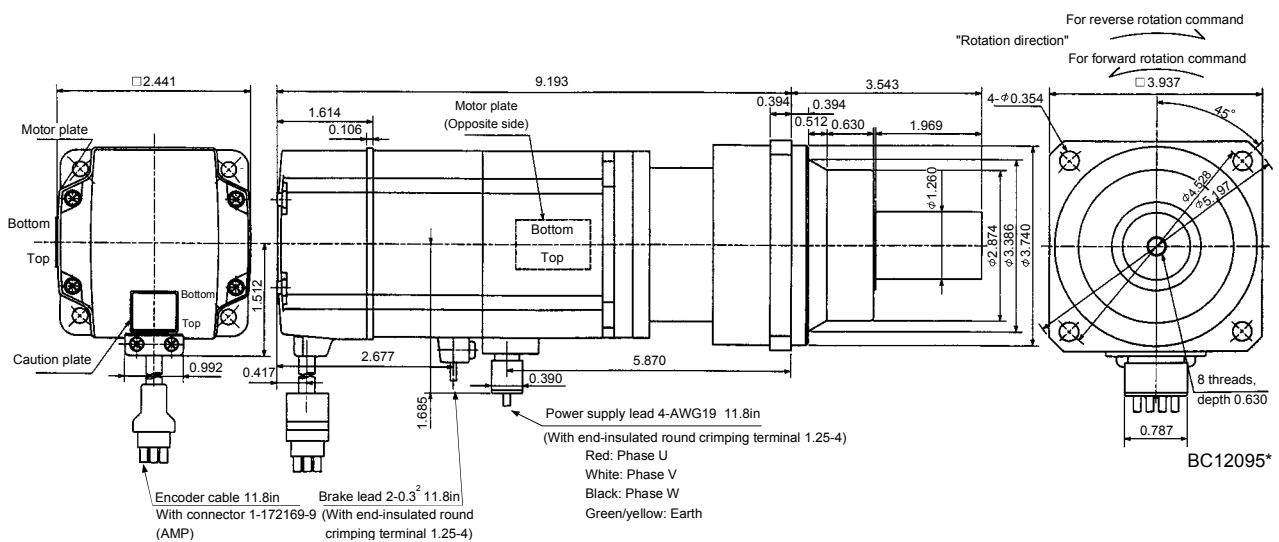

7. OUTLINE DIMENSION DRAWINGS

(4) With reduction gear for precision application

The outer frame of the reduction gear is a material surface such as casting. Its actual dimensions may be 0.039 to 0.118 in larger than the drawing dimensions. Design the machine side with allowances.

(a) Without electromagnetic brake

Model	Output [W]	Variable Dimensions [in]		Reduction Gear Model	Reduction Ratio	Inertia Moment WK ² [oz · in ²]	Backlash	Mass [lb]
		L	KL					
HC-MF053G2	50	5.12	3.07	BK1-05B-A5MEKA	1/5	0.36	3 min. max.	3.1
HC-MF053G2	50	5.75	3.70	BK1-09B-A5MEKA	1/9	0.33	3 min. max.	3.7
HC-MF053G2	50	5.75	3.70	BK1-20B-A5MEKA	1/20	0.38	3 min. max.	4.0
HC-MF053G2	50	5.75	3.70	BK1-29B-A5MEKA	1/29	0.31	3 min. max.	4.0
HC-KF053G2	50	5.12	3.07	BK1-05B-A5MEKA	1/5	0.55	3 min. max.	3.1
HC-KF053G2	50	5.75	3.70	BK1-09B-A5MEKA	1/9	0.52	3 min. max.	3.7
HC-KF053G2	50	5.75	3.70	BK1-20B-A5MEKA	1/20	0.57	3 min. max.	4.0
HC-KF053G2	50	5.75	3.70	BK1-29B-A5MEKA	1/29	0.50	3 min. max.	4.0

[Unit: in]

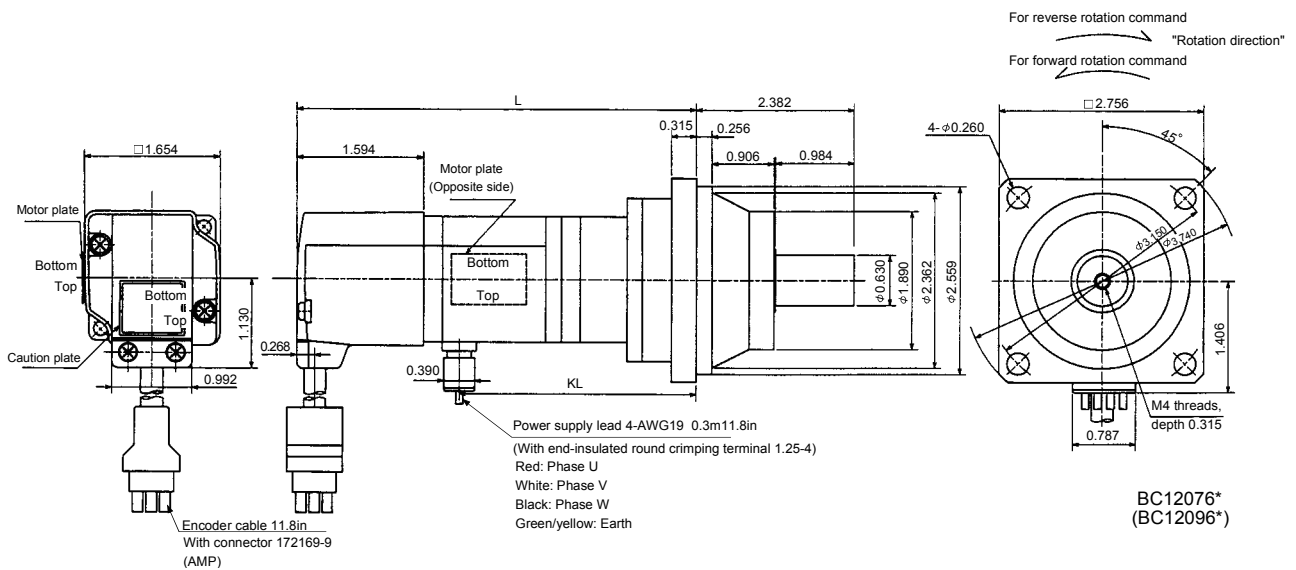

7. OUTLINE DIMENSION DRAWINGS

Model	Output [W]	Reduction Gear Model	Reduction Ratio	Inertia Moment Wk^2 [oz · in ²]	Backlash	Mass [lb]
HC-MF13G2	100	BK1-05B-01MEKA	1/5	0.43	3 min. max.	3.3
HC-MF13G2	100	BK1-09B-01MEKA	1/9	0.39	3 min. max.	4.0
HC-MF13G2	100	BK2-20B-01MEKA	1/20	0.66	3 min. max.	6.6
HC-MF13G2	100	BK2-29B-01MEKA	1/29	0.52	3 min. max.	6.6

Model	Output [W]	Variable Dimensions [in]																
		LA	LB	LC	LD	LE	LF	LG	LH	LK	L	LR	KL	LZ	Q	S	P	R
HC-MF13G2	100	3.15	2.56	3.74	2.76	0.24	1.89	0.31	2.362	0.906	5.71	2.17	3.66	0.26	0.98	0.63	M4	0.31
HC-MF13G2	100	3.15	2.56	3.74	2.76	0.24	1.89	0.31	2.362	0.906	6.34	2.17	4.29	0.26	0.98	0.63	M4	0.31
HC-MF13G2	100	3.94	3.15	4.53	3.35	0.24	2.559	0.39	2.913	1.299	6.57	2.95	4.53	0.26	1.38	0.79	M5	0.39
HC-MF13G2	100	3.94	3.15	4.53	3.35	0.24	2.559	0.39	2.913	1.299	6.57	2.95	4.53	0.26	1.38	0.79	M5	0.39

Model	Output [W]	Reduction Gear Model	Reduction Ratio	Inertia Moment Wk^2 [oz · in ²]	Backlash	Mass [lb]
HC-KF13G2	100	BK1-05B-01MEKA	1/5	0.72	3 min. max.	3.3
HC-KF13G2	100	BK1-09B-01MEKA	1/9	0.69	3 min. max.	4.0
HC-KF13G2	100	BK2-20B-01MEKA	1/20	0.96	3 min. max.	6.6
HC-KF13G2	100	BK2-29B-01MEKA	1/29	0.82	3 min. max.	6.6

Model	Output [W]	Variable Dimensions [in]																
		LA	LB	LC	LD	LE	LF	LG	LH	LK	L	LR	KL	LZ	Q	S	P	R
HC-KF13G2	100	3.15	2.56	3.74	2.76	0.24	1.89	0.31	2.362	0.906	5.71	2.17	3.66	0.26	0.98	0.63	M4	0.31
HC-KF13G2	100	3.15	2.56	3.74	2.76	0.24	1.89	0.31	2.362	0.906	6.34	2.17	4.29	0.26	0.98	0.63	M4	0.31
HC-KF13G2	100	3.94	3.15	4.53	3.35	0.24	2.559	0.39	2.913	1.299	6.57	2.95	4.53	0.26	1.38	0.79	M5	0.39
HC-KF13G2	100	3.94	3.15	4.53	3.35	0.24	2.559	0.39	2.913	1.299	6.57	2.95	4.53	0.26	1.38	0.79	M5	0.39

[Unit: in]

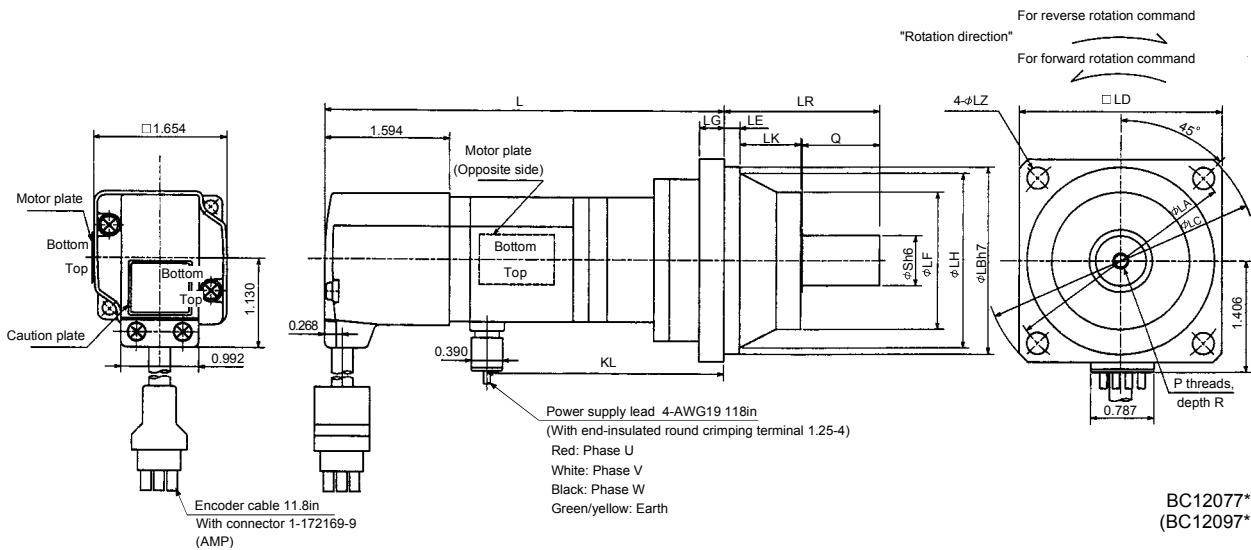

BC12077*
(BC12097*)

7. OUTLINE DIMENSION DRAWINGS

Model	Output [W]	Reduction Gear Model	Reduction Ratio	Inertia Moment WK^2 [oz · in ²]	Mass [lb]
HC-MF23G2	200	BK1-05B-02MEKA	1/5	1.04	4.6
HC-MF23G2	200	BK2-09B-02MEKA	1/9	1.14	7.7
HC-MF23G2	200	BK3-20B-02MEKA	1/20	1.95	11.0
HC-MF23G2	200	BK3-29B-02MEKA	1/29	1.51	11.0

Model	Output [W]	Variable Dimensions [in]																
		LA	LB	LC	LD	LE	LF	LG	LH	LK	L	LR	KL	LZ	Q	S	P	R
HC-MF23G2	200	3.15	2.56	3.74	2.76	0.24	1.89	0.31	2.362	0.906	6.18	2.17	4.20	0.26	0.98	0.63	M4	0.31
HC-MF23G2	200	3.94	3.15	4.53	3.35	0.24	2.559	0.39	2.913	1.299	6.89	2.95	4.91	0.26	1.38	0.79	M5	0.39
HC-MF23G2	200	4.53	3.74	5.31	3.94	0.31	2.953	0.39	3.346	1.378	7.09	3.35	5.10	0.35	1.57	0.98	M6	0.47
HC-MF23G2	200	4.53	3.74	5.31	3.94	0.31	2.953	0.39	3.346	1.378	7.09	3.35	5.10	0.35	1.57	0.98	M6	0.47

Model	Output [W]	Reduction Gear Model	Reduction Ratio	Inertia Moment WK^2 [oz · in ²]	Mass [lb]
HC-KF23G2	200	BK1-05B-02MEKA	1/5	1.968	4.6
HC-KF23G2	200	BK2-09B-02MEKA	1/9	2.078	7.7
HC-KF23G2	200	BK3-20B-02MEKA	1/20	2.898	11.0
HC-KF23G2	200	BK3-29B-02MEKA	1/29	2.460	11.0

Model	Output [W]	Variable Dimensions [in]																
		LA	LB	LC	LD	LE	LF	LG	LH	LK	L	LR	KL	LZ	Q	S	P	R
HC-KF23G2	200	3.15	2.56	3.74	2.76	0.24	1.89	0.31	2.362	0.906	6.18	2.17	4.20	0.26	0.98	0.63	M4	0.31
HC-KF23G2	200	3.94	3.15	4.53	3.35	0.24	2.559	0.39	2.913	1.299	6.89	2.95	4.91	0.26	1.38	0.79	M5	0.39
HC-KF23G2	200	4.53	3.74	5.31	3.94	0.31	2.953	0.39	3.346	1.378	7.09	3.35	5.10	0.35	1.57	0.98	M6	0.47
HC-KF23G2	200	4.53	3.74	5.31	3.94	0.31	2.953	0.39	3.346	1.378	7.09	3.35	5.10	0.35	1.57	0.98	M6	0.47

[Unit: in]

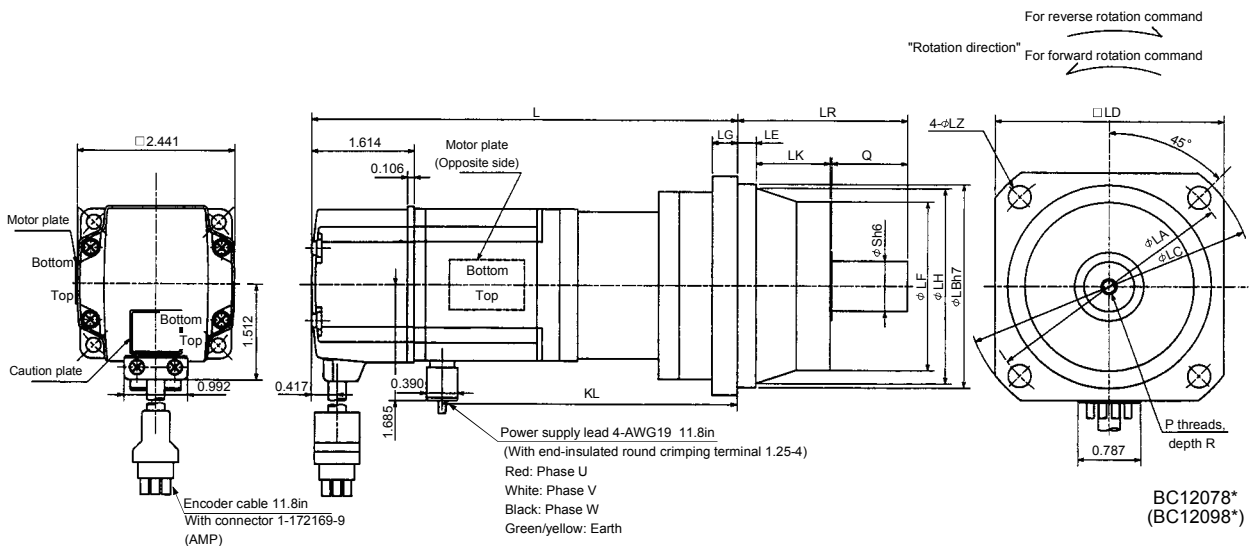

7. OUTLINE DIMENSION DRAWINGS

Model	Output [W]	Reduction Gear Model	Reduction Ratio	Inertia Moment Wk^2 [oz · in ²]	Mass [lb]
HC-MF43G2	400	BK2-05B-04MEKA	1/5	1.61	8.2
HC-MF43G2	400	BK3-09B-04MEKA	1/9	1.77	11.7
HC-MF43G2	400	BK4-20B-04MEKA	1/20	2.33	16.5
HC-MF43G2	400	BK4-29B-04MEKA	1/29	1.85	16.5

Model	Output [W]	Variable Dimensions [in]																
		LA	LB	LC	LD	LE	LF	LG	LH	LK	L	LR	KL	LZ	Q	S	P	R
HC-MF43G2	400	3.94	3.15	4.53	3.35	0.24	2.56	0.39	2.91	1.3	7.24	2.95	5.18	0.26	1.38	0.79	M5	0.39
HC-MF43G2	400	4.53	3.74	5.32	3.94	0.31	2.95	0.39	3.35	1.38	8.07	3.35	6.01	0.35	1.58	0.98	M6	0.47
HC-MF43G2	400	5.32	3.94	6.10	4.53	0.31	3.54	0.47	3.94	1.58	8.31	3.94	6.24	0.43	1.97	1.26	M8	0.63
HC-MF43G2	400	5.32	4.33	6.10	4.53	0.31	3.54	0.47	3.94	1.58	8.31	3.94	6.24	0.43	1.97	1.26	M8	0.63

Model	Output [W]	Reduction Gear Model	Reduction Ratio	Inertia Moment Wk^2 [oz · in ²]	Mass [lb]
HC-KF43G2	400	BK2-05B-04MEKA	1/5	3.335	8.2
HC-KF43G2	400	BK3-09B-04MEKA	1/9	3.499	11.7
HC-KF43G2	400	BK4-20B-04MEKA	1/20	4.046	16.5
HC-KF43G2	400	BK4-29B-04MEKA	1/29	3.609	16.5

Model	Output [W]	Variable Dimensions [in]																
		LA	LB	LC	LD	LE	LF	LG	LH	LK	L	LR	KL	LZ	Q	S	P	R
HC-KF43G2	400	3.94	3.15	4.53	3.35	0.24	2.56	0.39	2.91	1.3	7.24	2.95	5.18	0.26	1.38	0.79	M5	0.39
HC-KF43G2	400	4.53	3.74	5.32	3.94	0.31	2.95	0.39	3.35	1.38	8.07	3.35	6.01	0.35	1.58	0.98	M6	0.47
HC-KF43G2	400	5.32	3.94	6.10	4.53	0.31	3.54	0.47	3.94	1.58	8.31	3.94	6.24	0.43	1.97	1.26	M8	0.63
HC-KF43G2	400	5.32	4.33	6.10	4.53	0.31	3.54	0.47	3.94	1.58	8.31	3.94	6.24	0.43	1.97	1.26	M8	0.63

[Unit: in]

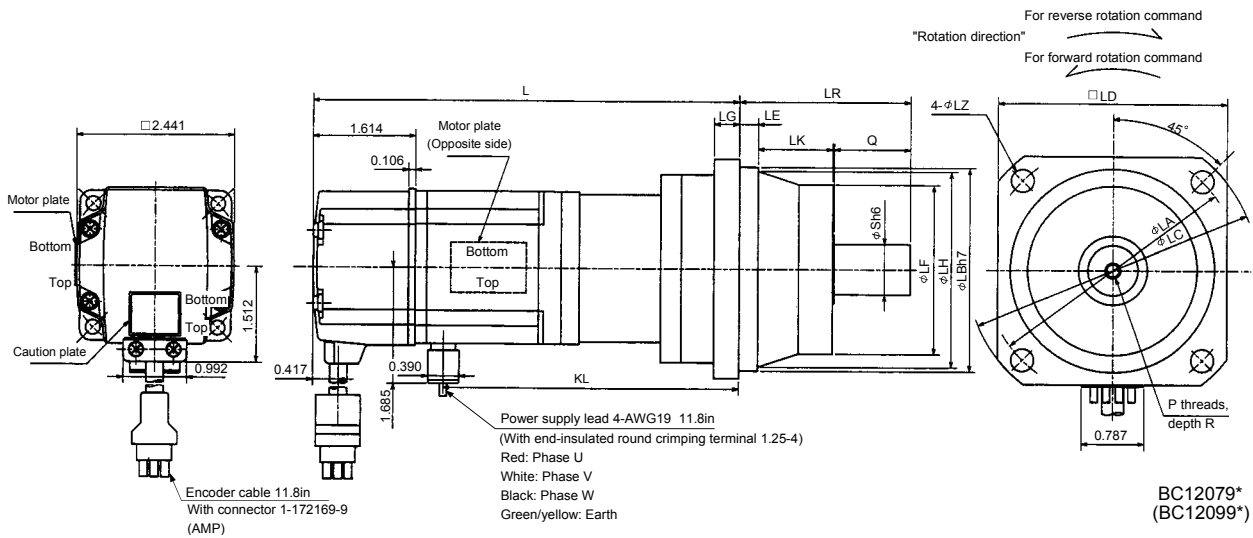

7. OUTLINE DIMENSION DRAWINGS

Model	Output [W]	Reduction Gear Model	Reduction Ratio	Inertia Moment Wk^2 [oz · in ²]	Mass [lb]
HC-MF73G2	750	BK3-05B-08MEKA	1/5	5.32	13.89
HC-MF73G2	750	BK4-09B-08MEKA	1/9	5.36	18.96
HC-MF73G2	750	BK5-20B-08MEKA	1/20	5.55	26.46
HC-MF73G2	750	BK5-29B-08MEKA	1/29	4.97	26.46

Model	Output [W]	Variable Dimensions [in]																
		LA	LB	LC	LD	LE	LF	LG	LH	LK	L	LR	KL	LZ	Q	S	P	R
HC-MF73G2	750	4.53	3.74	5.31	3.94	0.31	2.953	0.39	3.346	1.378	8.35	3.35	6.17	0.35	1.57	0.98	M6	0.47
HC-MF73G2	750	5.31	4.33	6.10	4.53	0.31	3.543	0.47	3.937	1.575	9.76	3.94	7.27	0.43	1.97	1.26	M8	0.63
HC-MF73G2	750	5.91	4.92	6.89	5.12	0.39	4.134	0.59	4.528	1.693	9.76	4.53	7.59	0.55	2.36	1.57	M10	0.79
HC-MF73G2	750	5.91	4.92	6.89	5.12	0.39	4.134	0.59	4.528	1.693	9.76	4.53	7.59	0.55	2.36	1.57	M10	0.79

[Unit: in]

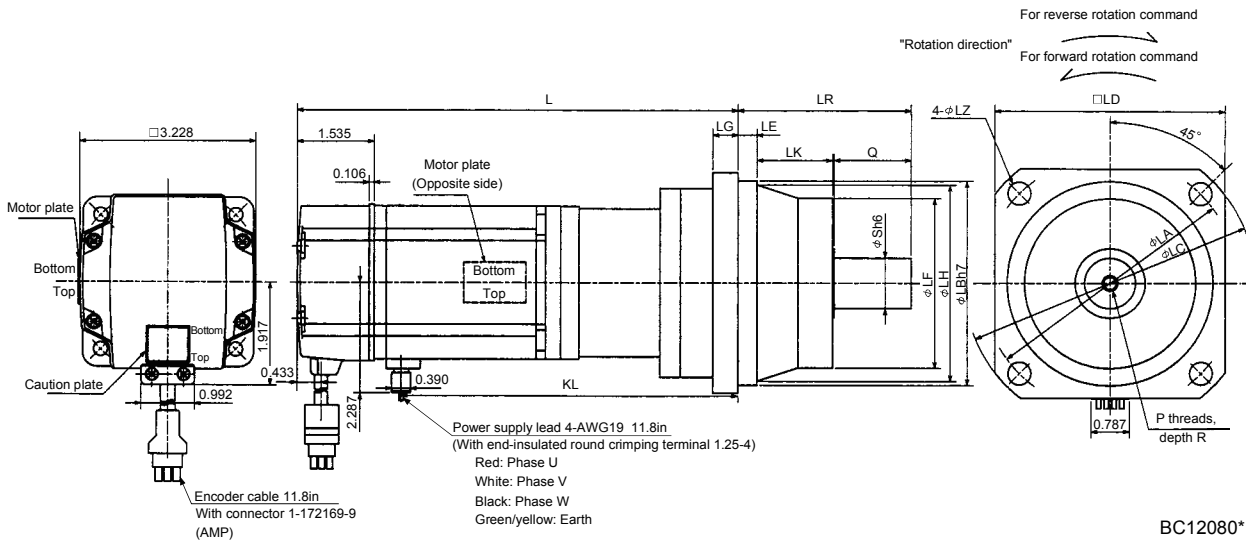

7. OUTLINE DIMENSION DRAWINGS

(b) With electromagnetic brake

Model	Output [W]	Variable Dimensions [in]		Brake static friction torque [oz · in]	Reduction Gear Model	Reduction Ratio	Inertia Moment WK^2 [oz · in ²]	Backlash	Mass [lb]
		L	KL						
HC-MF053BG2	50	6.22	3.07	45	BK1-05B-A5MEKA	1/5	0.38	3 min. max.	4.0
HC-MF053BG2	50	6.85	3.70	45	BK1-09B-A5MEKA	1/9	0.34	3 min. max.	4.6
HC-MF053BG2	50	6.85	3.70	45	BK1-20B-A5MEKA	1/20	0.39	3 min. max.	4.9
HC-MF053BG2	50	6.85	3.70	45	BK1-29B-A5MEKA	1/29	0.33	3 min. max.	4.9
HC-KF053BG2	50	6.22	3.07	45	BK1-05B-A5MEKA	1/5	0.57	3 min. max.	4.0
HC-KF053BG2	50	6.85	3.70	45	BK1-09B-A5MEKA	1/9	0.54	3 min. max.	4.6
HC-KF053BG2	50	6.85	3.70	45	BK1-20B-A5MEKA	1/20	0.59	3 min. max.	4.9
HC-KF053BG2	50	6.85	3.70	45	BK1-29B-A5MEKA	1/29	0.52	3 min. max.	4.9

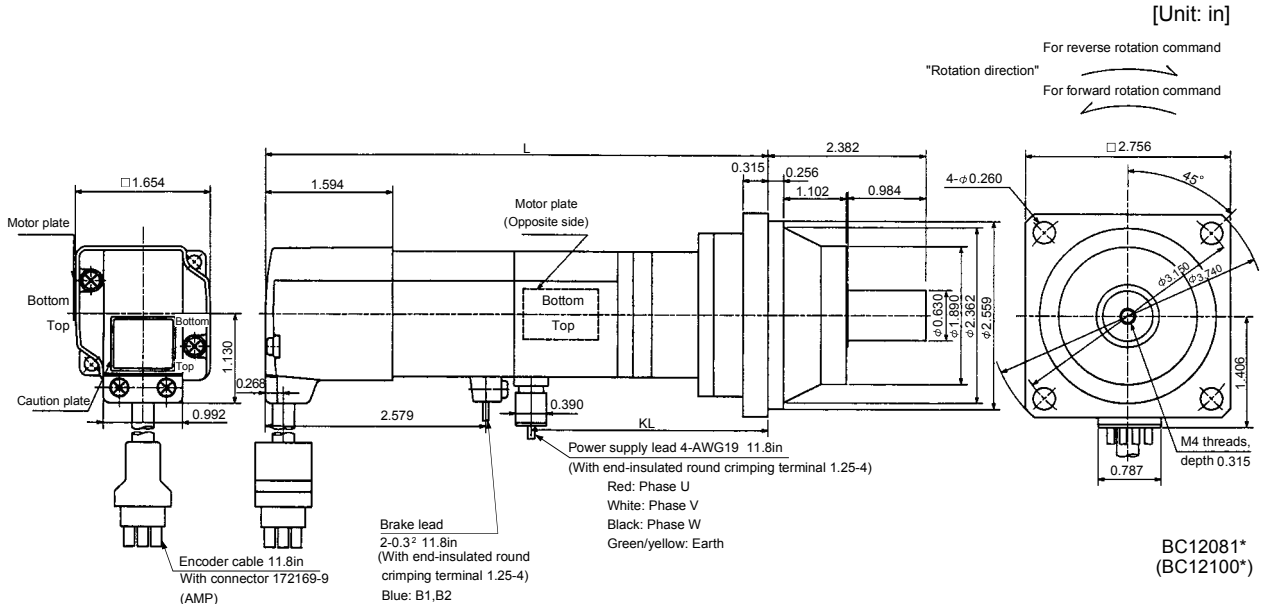

7. OUTLINE DIMENSION DRAWINGS

Model	Output [W]	Brake static friction torque [oz · in]	Reduction Gear Model	Reduction Ratio	Inertia Moment WK^2 [oz · in ²]	Backlash	Mass [lb]
HC-MF13BG2	100	45	BK1-05B-01MEKA	1/5	0.44	3 min. max.	4.2
HC-MF13BG2	100	45	BK1-09B-01MEKA	1/9	0.40	3 min. max.	4.9
HC-MF13BG2	100	45	BK2-20B-01MEKA	1/20	0.68	3 min. max.	7.5
HC-MF13BG2	100	45	BK2-29B-01MEKA	1/29	0.53	3 min. max.	7.5

Model	Output [W]	Variable Dimensions [in]																
		LA	LB	LC	LD	LE	LF	LG	LH	LK	L	LR	KL	LZ	Q	S	P	R
HC-MF13BG2	100	3.15	2.56	3.74	2.76	0.24	1.89	0.31	2.362	0.906	6.81	2.17	3.66	0.26	0.98	0.63	M4	0.31
HC-MF13BG2	100	3.15	2.56	3.74	2.76	0.24	1.89	0.31	2.362	0.906	7.44	2.17	4.29	0.26	0.98	0.63	M4	0.31
HC-MF13BG2	100	3.94	3.15	4.53	3.35	0.24	2.559	0.39	2.913	1.299	7.68	2.95	4.53	0.26	1.38	0.79	M5	0.39
HC-MF13BG2	100	3.94	3.15	4.53	3.35	0.24	2.559	0.39	2.913	1.299	7.68	2.95	4.53	0.26	1.38	0.79	M5	0.39

Model	Output [W]	Brake static friction torque [oz · in]	Reduction Gear Model	Reduction Ratio	Inertia Moment WK^2 [oz · in ²]	Backlash	Mass [lb]
HC-KF13BG2	100	45	BK1-05B-01MEKA	1/5	0.74	3 min. max.	4.2
HC-KF13BG2	100	45	BK1-09B-01MEKA	1/9	0.71	3 min. max.	4.9
HC-KF13BG2	100	45	BK2-20B-01MEKA	1/20	0.98	3 min. max.	7.5
HC-KF13BG2	100	45	BK2-29B-01MEKA	1/29	0.84	3 min. max.	7.5

Model	Output [W]	Variable Dimensions [in]																
		LA	LB	LC	LD	LE	LF	LG	LH	LK	L	LR	KL	LZ	Q	S	P	R
HC-KF13BG2	100	3.15	2.56	3.74	2.76	0.24	1.89	0.31	2.362	0.906	6.81	2.17	3.66	0.26	0.98	0.63	M4	0.31
HC-KF13BG2	100	3.15	2.56	3.74	2.76	0.24	1.89	0.31	2.362	0.906	7.44	2.17	4.29	0.26	0.98	0.63	M4	0.31
HC-KF13BG2	100	3.94	3.15	4.53	3.35	0.24	2.559	0.39	2.913	1.299	7.68	2.95	4.53	0.26	1.38	0.79	M5	0.39
HC-KF13BG2	100	3.94	3.15	4.53	3.35	0.24	2.559	0.39	2.913	1.299	7.68	2.95	4.53	0.26	1.38	0.79	M5	0.39

[Unit: in]

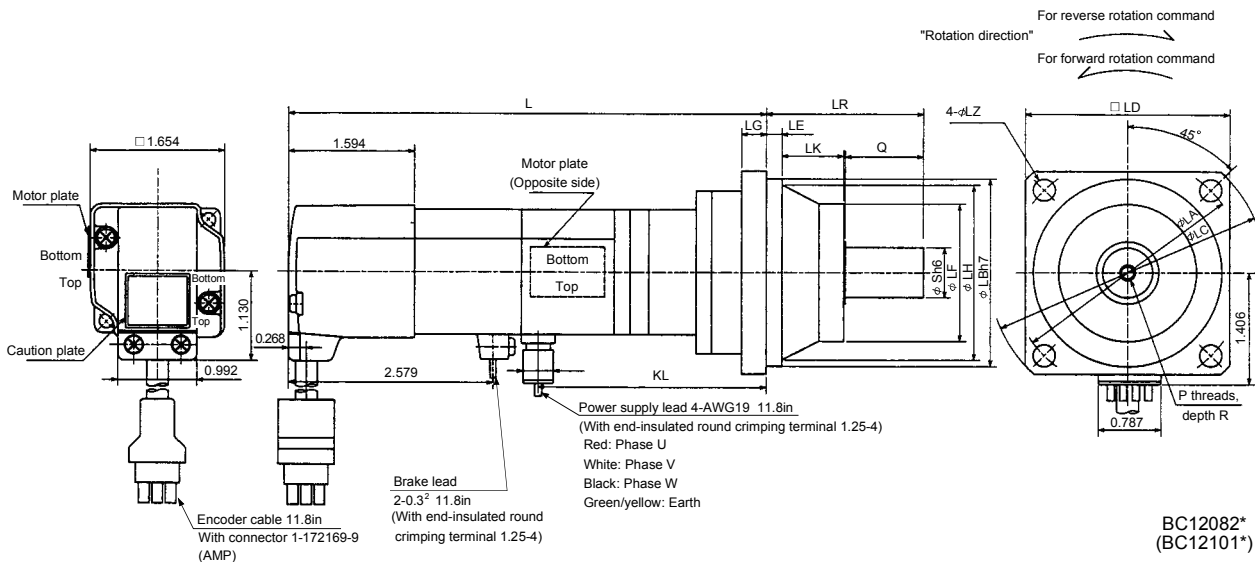

7. OUTLINE DIMENSION DRAWINGS

Model	Output [W]	Brake static friction torque [oz · in]	Reduction Gear Model	Reduction Ratio	Inertia Moment WK ² [oz · in ²]	Mass [lb]
HC-MF23BG2	200	184	BK1-05B-02MEKA	1/5	1.31	6.0
HC-MF23BG2	200	184	BK2-09B-02MEKA	1/9	1.40	9.0
HC-MF23BG2	200	184	BK3-20B-02MEKA	1/20	2.21	12.3
HC-MF23BG2	200	184	BK3-29B-02MEKA	1/29	1.77	12.3

Model	Output [W]	Variable Dimensions [in]																
		LA	LB	LC	LD	LE	LF	LG	LH	LK	L	LR	KL	LZ	Q	S	P	R
HC-MF23BG2	200	3.15	2.56	3.74	2.76	0.24	1.89	0.31	2.362	0.906	7.44	2.17	4.20	0.26	0.98	0.63	M4	0.31
HC-MF23BG2	200	3.94	3.15	4.53	3.35	0.24	2.559	0.39	2.913	1.299	8.15	2.95	4.91	0.26	1.38	0.79	M5	0.39
HC-MF23BG2	200	4.53	3.74	5.31	3.94	0.31	2.953	0.39	3.346	1.378	8.35	3.35	5.10	0.35	1.57	0.98	M6	0.47
HC-MF23BG2	200	4.53	3.74	5.31	3.94	0.31	2.953	0.39	3.346	1.378	8.35	3.35	5.10	0.35	1.57	0.98	M6	0.47

Model	Output [W]	Brake static friction torque [oz · in]	Reduction Gear Model	Reduction Ratio	Inertia Moment WK ² [oz · in ²]	Mass [lb]
HC-KF23BG2	200	184	BK1-05B-02MEKA	1/5	2.242	6.0
HC-KF23BG2	200	184	BK2-09B-02MEKA	1/9	2.351	9.0
HC-KF23BG2	200	184	BK3-20B-02MEKA	1/20	3.171	12.3
HC-KF23BG2	200	184	BK3-29B-02MEKA	1/29	2.734	12.3

Model	Output [W]	Variable Dimensions [in]																
		LA	LB	LC	LD	LE	LF	LG	LH	LK	L	LR	KL	LZ	Q	S	P	R
HC-KF23BG2	200	3.15	2.56	3.74	2.76	0.24	1.89	0.31	2.362	0.906	7.44	2.17	4.20	0.26	0.98	0.63	M4	0.31
HC-KF23BG2	200	3.94	3.15	4.53	3.35	0.24	2.559	0.39	2.913	1.299	8.15	2.95	4.91	0.26	1.38	0.79	M5	0.39
HC-KF23BG2	200	4.53	3.74	5.31	3.94	0.31	2.953	0.39	3.346	1.378	8.35	3.35	5.10	0.35	1.57	0.98	M6	0.47
HC-KF23BG2	200	4.53	3.74	5.31	3.94	0.31	2.953	0.39	3.346	1.378	8.35	3.35	5.10	0.35	1.57	0.98	M6	0.47

[Unit: in]

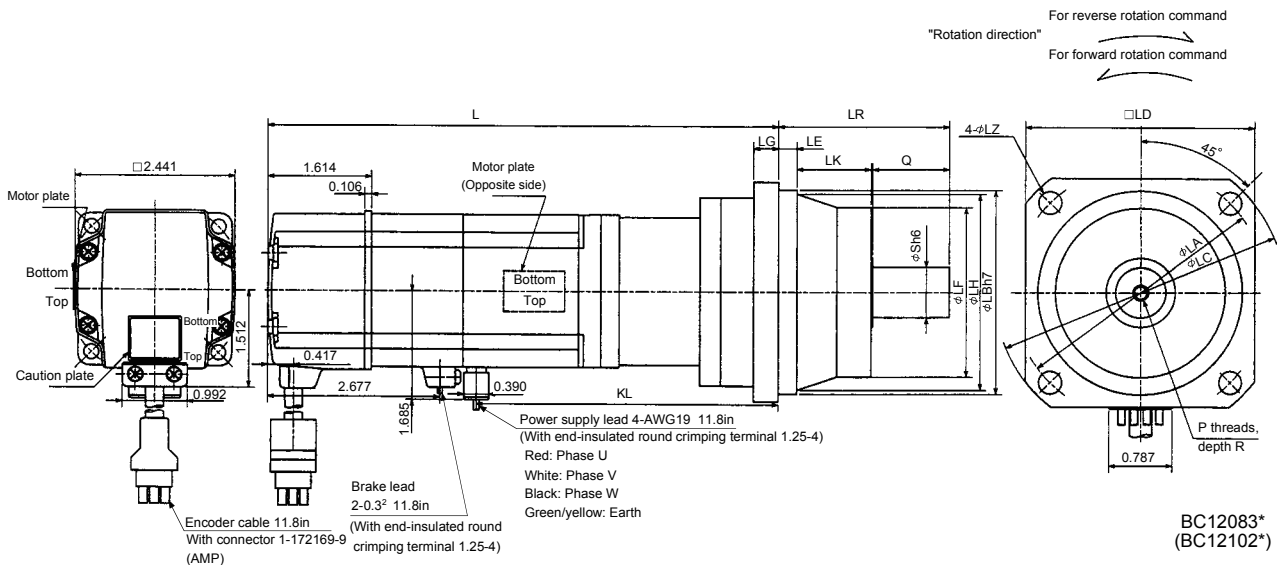

7. OUTLINE DIMENSION DRAWINGS

Model	Output [W]	Brake static friction torque [oz · in]	Reduction Gear Model	Reduction Ratio	Inertia Moment WK ² [oz · in ²]	Mass [lb]
HC-MF43BG2	400	184	BK2-05B-04MEKA	1/5	1.88	9.5
HC-MF43BG2	400	184	BK3-09B-04MEKA	1/9	2.03	13.0
HC-MF43BG2	400	184	BK4-20B-04MEKA	1/20	2.59	17.9
HC-MF43BG2	400	184	BK4-29B-04MEKA	1/29	2.11	17.9

Model	Output [W]	Variable Dimensions [in]																
		LA	LB	LC	LD	LE	LF	LG	LH	LK	L	LR	KL	LZ	Q	S	P	R
HC-MF43BG2	400	3.94	3.15	4.53	3.35	0.24	2.559	0.39	2.913	1.299	8.50	2.95	5.18	0.26	1.38	0.79	M5	0.39
HC-MF43BG2	400	4.53	3.74	5.31	3.94	0.31	2.953	0.39	3.346	1.378	9.33	3.35	6.01	0.35	1.57	0.98	M6	0.47
HC-MF43BG2	400	5.31	4.33	6.10	4.53	0.31	3.543	0.47	3.937	1.575	9.57	3.94	6.24	0.43	1.97	1.26	M8	0.63
HC-MF43BG2	400	5.31	4.33	6.10	4.53	0.31	3.543	0.47	3.937	1.575	9.57	3.94	6.24	0.43	1.97	1.26	M8	0.63

Model	Output [W]	Brake static friction torque [oz · in]	Reduction Gear Model	Reduction Ratio	Inertia Moment WK ² [oz · in ²]	Mass [lb]
HC-KF43BG2	400	184	BK2-05B-04MEKA	1/5	3.609	9.5
HC-KF43BG2	400	184	BK3-09B-04MEKA	1/9	3.773	13.0
HC-KF43BG2	400	184	BK4-20B-04MEKA	1/20	4.319	17.9
HC-KF43BG2	400	184	BK4-29B-04MEKA	1/29	3.882	17.9

Model	Output [W]	Variable Dimensions [in]																
		LA	LB	LC	LD	LE	LF	LG	LH	LK	L	LR	KL	LZ	Q	S	P	R
HC-KF43BG2	400	3.94	3.15	4.53	3.35	0.24	2.559	0.39	2.913	1.299	8.50	2.95	5.18	0.26	1.38	0.79	M5	0.39
HC-KF43BG2	400	4.53	3.74	5.31	3.94	0.31	2.953	0.39	3.346	1.378	9.33	3.35	6.01	0.35	1.57	0.98	M6	0.47
HC-KF43BG2	400	5.31	4.33	6.10	4.53	0.31	3.543	0.47	3.937	1.575	9.57	3.94	6.24	0.43	1.97	1.26	M8	0.63
HC-KF43BG2	400	5.31	4.33	6.10	4.53	0.31	3.543	0.47	3.937	1.575	9.57	3.94	6.24	0.43	1.97	1.26	M8	0.63

[Unit: in]

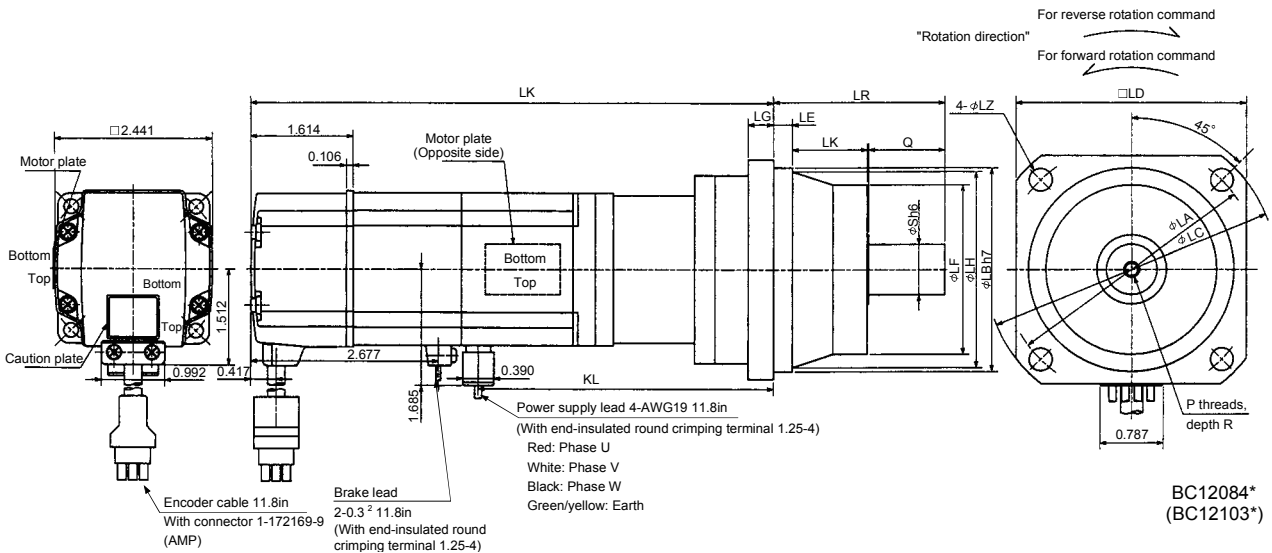

7. OUTLINE DIMENSION DRAWINGS

Model	Output [W]	Brake static friction torque [oz · in]	Reduction Gear Model	Reduction Ratio	Inertia Moment WK ² [oz · in ²]	Mass [lb]
HC-MF73BG2	750	340	BK3-05B-08MEKA	1/5	6.00	16.1
HC-MF73BG2	750	340	BK4-09B-08MEKA	1/9	6.04	21.2
HC-MF73BG2	750	340	BK5-20B-08MEKA	1/20	6.24	28.7
HC-MF73BG2	750	340	BK5-29B-08MEKA	1/29	5.66	28.7

Model	Output [W]	Variable Dimensions [in]																
		LA	LB	LC	LD	LE	LF	LG	LH	LK	L	LR	KL	LZ	Q	S	P	R
HC-MF73BG2	750	4.53	3.74	5.31	3.94	0.31	2.953	0.39	3.346	1.378	9.74	3.35	6.17	0.35	1.57	0.98	M6	0.47
HC-MF73BG2	750	5.31	4.33	6.10	4.53	0.31	3.543	0.47	3.937	1.575	10.85	3.94	7.27	0.43	1.97	1.26	M8	0.63
HC-MF73BG2	750	5.91	4.92	6.89	5.12	0.39	4.134	0.59	4.528	1.693	11.16	4.53	7.59	0.55	2.36	1.57	M10	0.79
HC-MF73BG2	750	5.91	4.92	6.89	5.12	0.39	4.134	0.59	4.528	1.693	11.16	4.53	7.59	0.55	2.36	1.57	M10	0.79

[Unit: in]

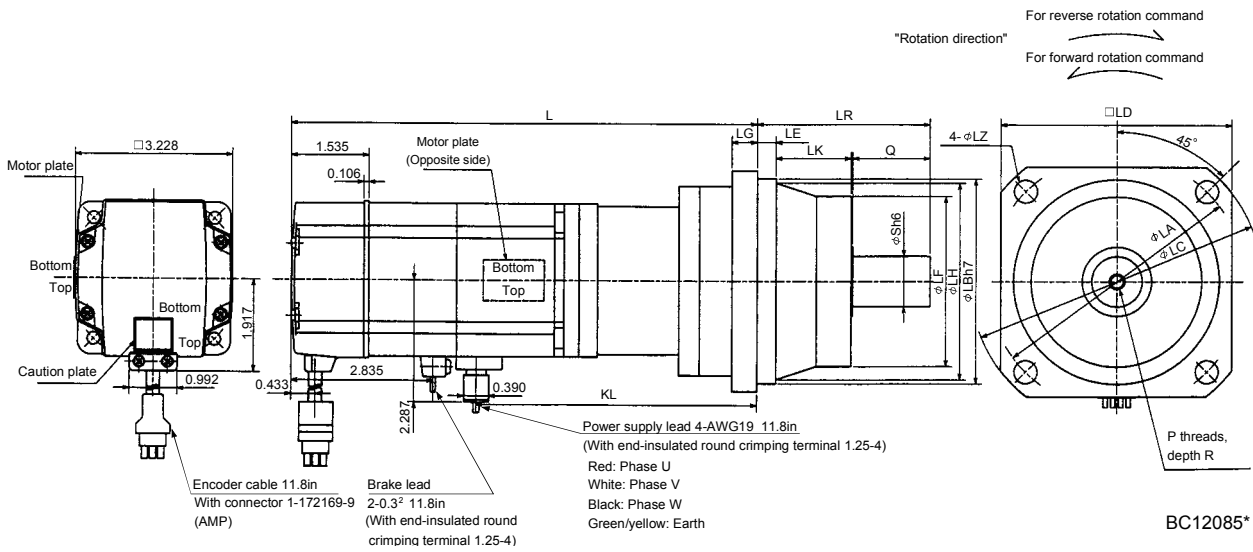

7. OUTLINE DIMENSION DRAWINGS

(5) EN • UL/C-UL Standard-compliant models

(a) Standard (without electromagnetic brake, without reduction gear)

Model	Output [W]	Variable Dimensions [in]		Inertia Moment WK ² [oz • in ²]	Mass [lb]
		L	KL		
HC-MF053-UE	50	3.52	1.48	0.10	1.1
HC-MF13-UE	100	4.11	2.07	0.16	1.3
HC-KF053-UE	50	3.52	1.48	0.30	1.1
HC-KF13-UE	100	4.11	2.07	0.47	1.3

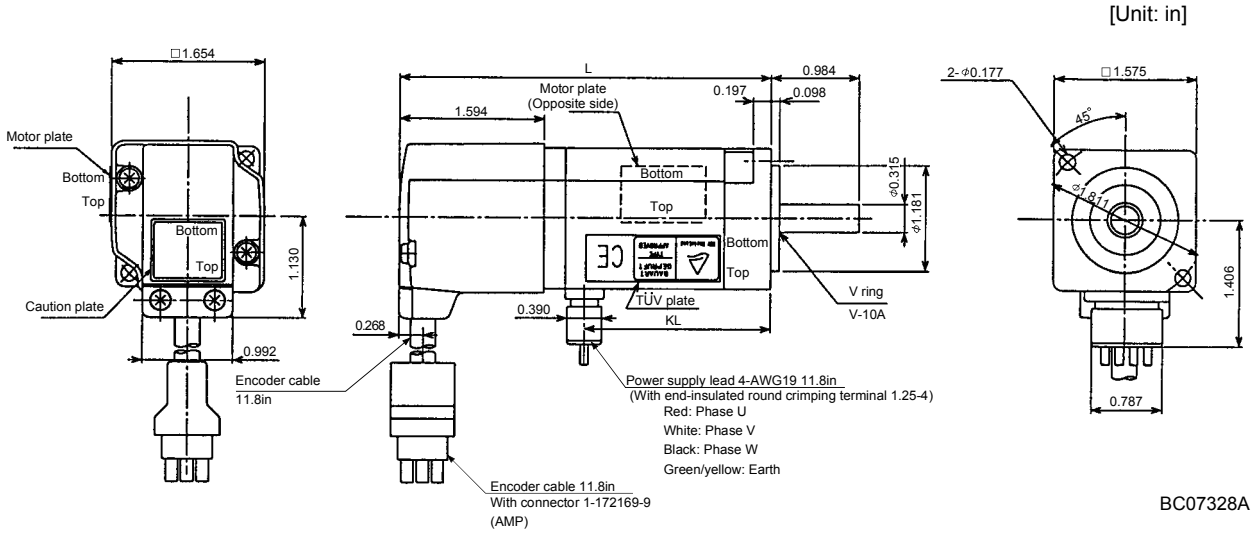

Model	Output [W]	Variable Dimensions [in]		Inertia Moment WK ² [oz • in ²]	Mass [lb]
		L	KL		
HC-MF23-UE	200	4.27	2.28	0.49	2.6
HC-MF43-UE	400	5.26	3.19	0.77	3.7
HC-KF23-UE	200	4.27	2.28	1.476	2.6
HC-KF43-UE	400	5.26	3.19	2.569	3.7

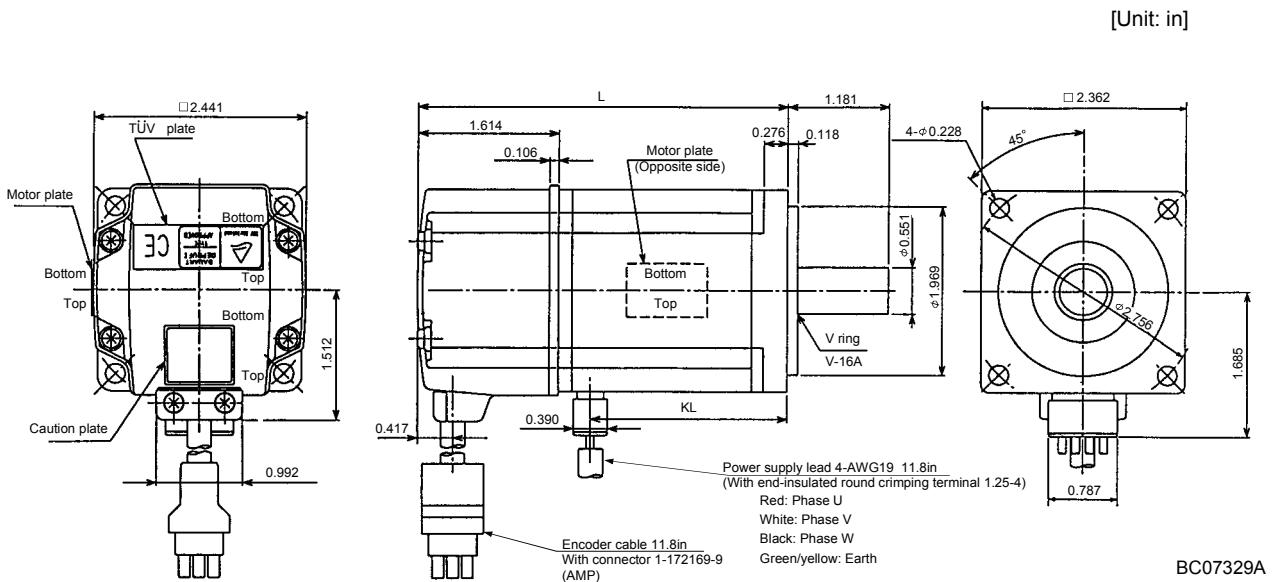

7. OUTLINE DIMENSION DRAWINGS

Model	Output [W]	Inertia Moment WK^2 [oz · in ²]	Mass [lb]
HC-MF73-UE	750	3.69	6.8

[Unit: in]

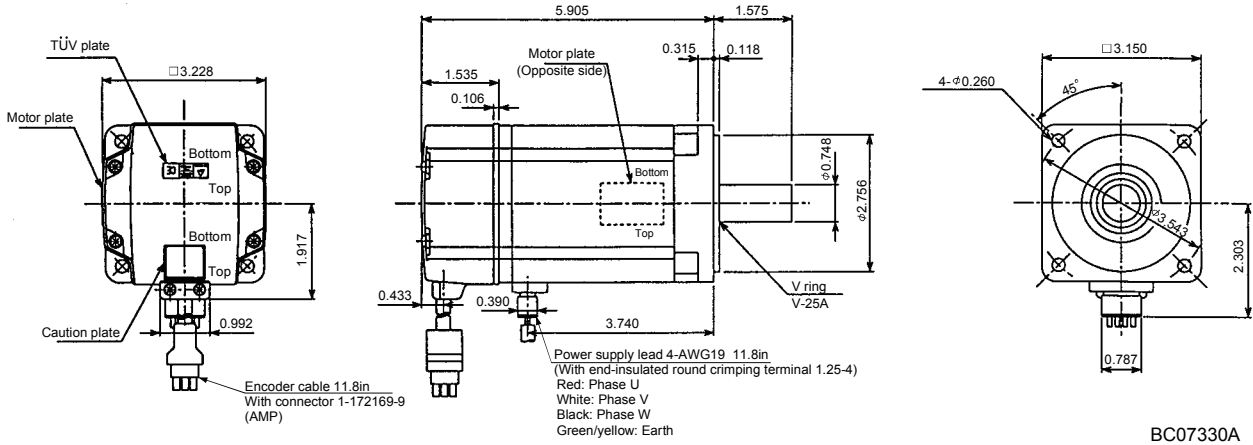

BC07330A

(b) With electromagnetic brake

Model	Output [W]	Variable Dimensions [in]		Brake static friction torque [oz · in]	Inertia Moment WK^2 [oz · in ²]	Mass [lb]
		L	KL			
HC-MF053B-UE	50	4.63	1.48	45	0.12	2.0
HC-MF13B-UE	100	5.22	2.08	45	0.18	2.2
HC-KF053B-UE	50	4.63	1.48	45	0.31	2.0
HC-KF13B-UE	100	5.22	2.08	45	0.48	2.2

[Unit: in]

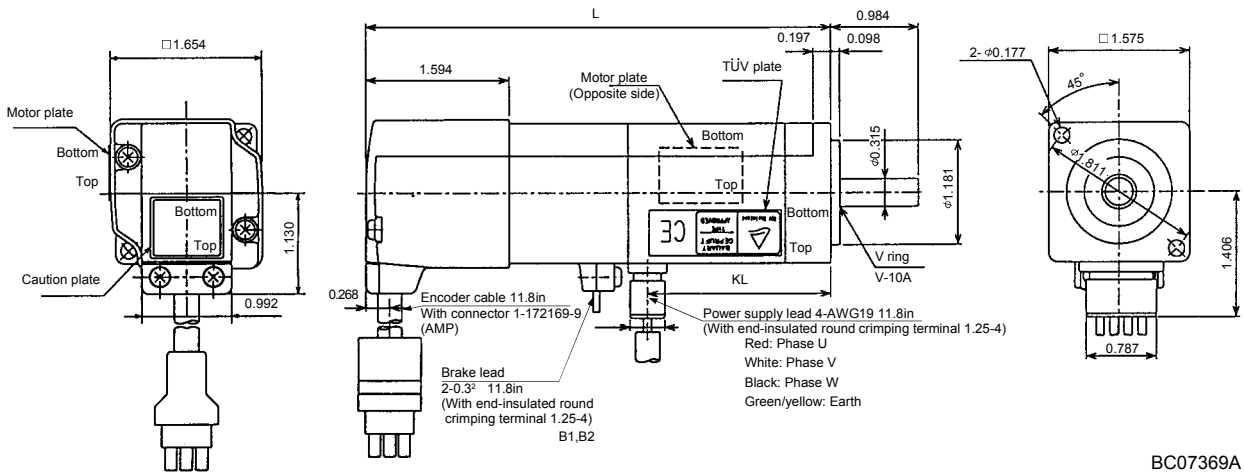

BC07369A

7. OUTLINE DIMENSION DRAWINGS

Model	Output [W]	Variable Dimensions [in]		Brake static friction torque [oz · in]	Inertia Moment WK ² [oz · in ²]	Mass [lb]
		L	KL			
HC-MF23B-UE	200	5.53	2.28	184	0.47	3.7
HC-MF43B-UE	400	6.52	3.19	184	1.04	4.9
HC-KF23B-UE	200	5.53	2.28	184	1.749	3.7
HC-KF43B-UE	400	6.52	3.19	184	2.843	4.9

[Unit: in]

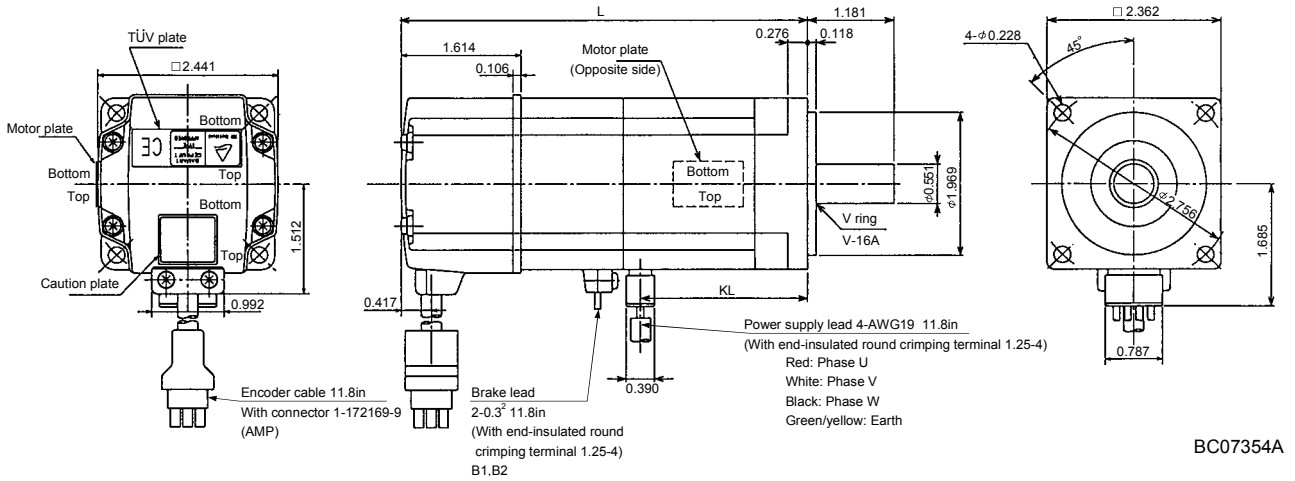

BC07354A

Model	Output [W]	Brake static friction torque [oz · in]	Inertia Moment WK ² [oz · in ²]	Mass [lb]
HC-MF73B-UE	750	340	4.10	9.3

[Unit: in]

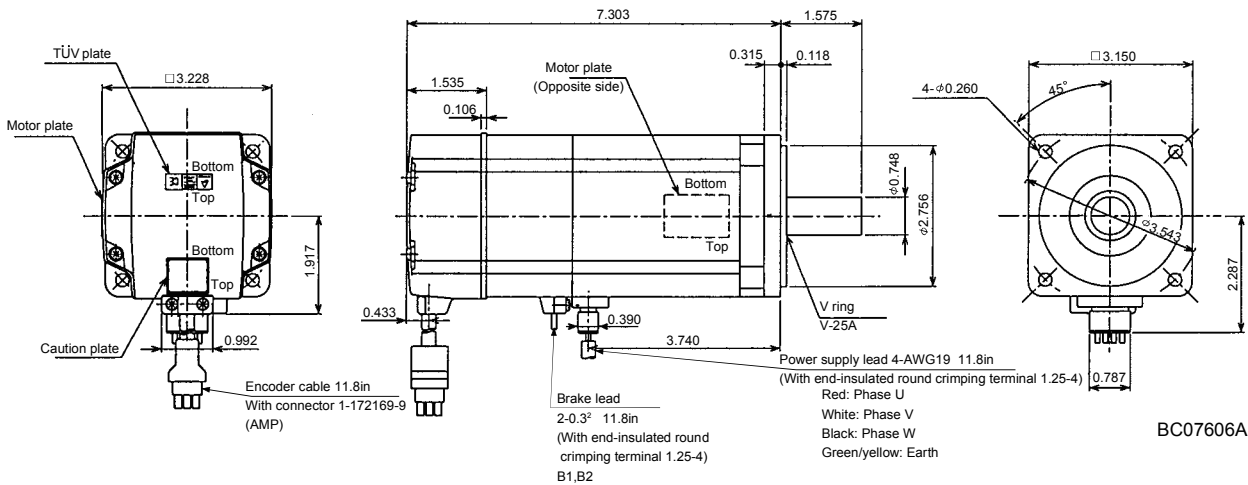

BC07606A

7. OUTLINE DIMENSION DRAWINGS

7.2.2 HA-FF series

(1) Standard (without electromagnetic brake, without reduction gear)

Model	Output [W]	Variable Dimensions [in]	Inertia Moment WK^2 [oz · in ²]	Mass [lb]
		L		
HA-FF053	50	4.17	0.34	2.9
HA-FF13	100	4.84	0.55	3.3

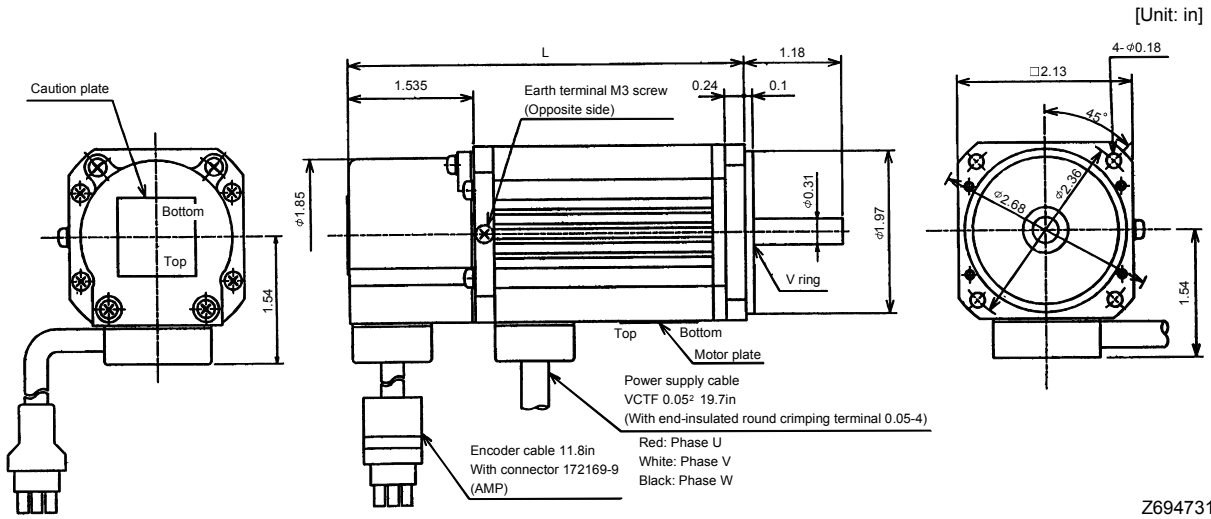

Model	Output [W]	Variable Dimensions [in]	Inertia Moment WK^2 [oz · in ²]	Mass [lb]
		L		
HA-FF23	200	5.138	1.91	5.1
HA-FF33	300	5.83	2.73	5.7

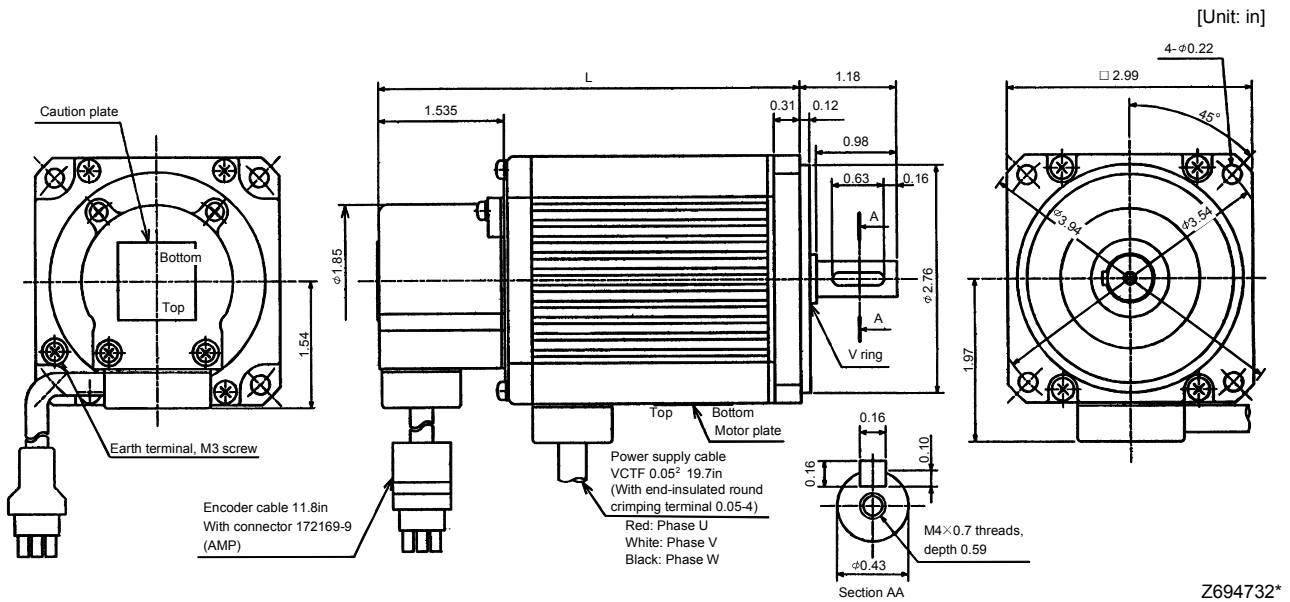

7. OUTLINE DIMENSION DRAWINGS

Model	Output [W]	Variable Dimensions [in]	Inertia Moment WK ² [oz · in ²]	Mass [lb]
		L		
HA-FF43	400	6.08	5.36	9.3
HA-FF63	600	6.67	6.56	10.6

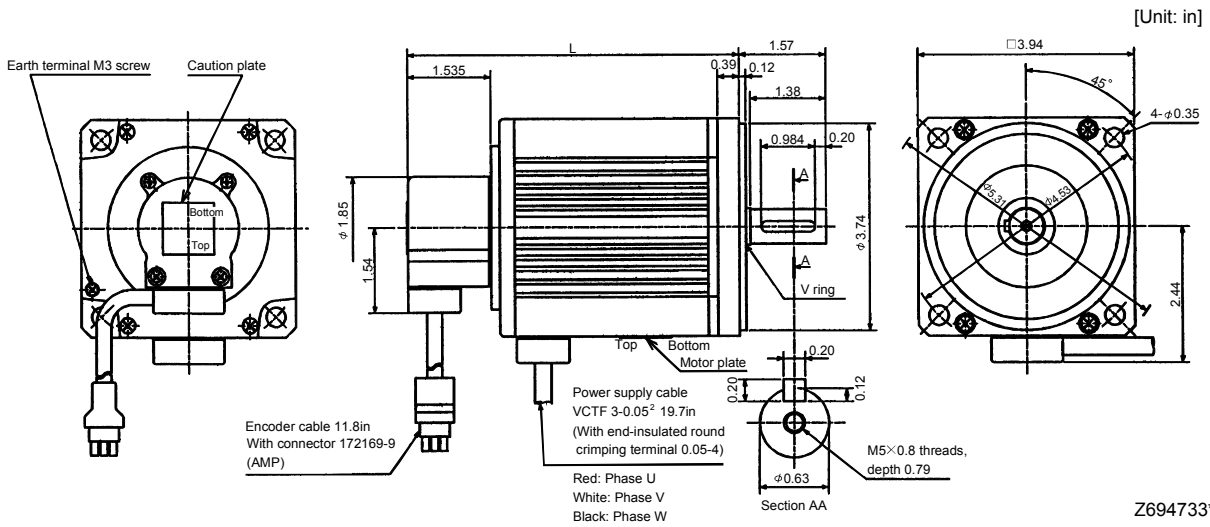

(2) With electromagnetic brake

Model	Output [W]	Variable Dimensions [in]	Brake static friction torque [oz · in]	Inertia Moment WK ² [oz · in ²]	Mass [lb]
		L			
HA-FF053B	50	5.551	55	0.44	3.5
HA-FF13B	100	6.22	55	0.60	4.0

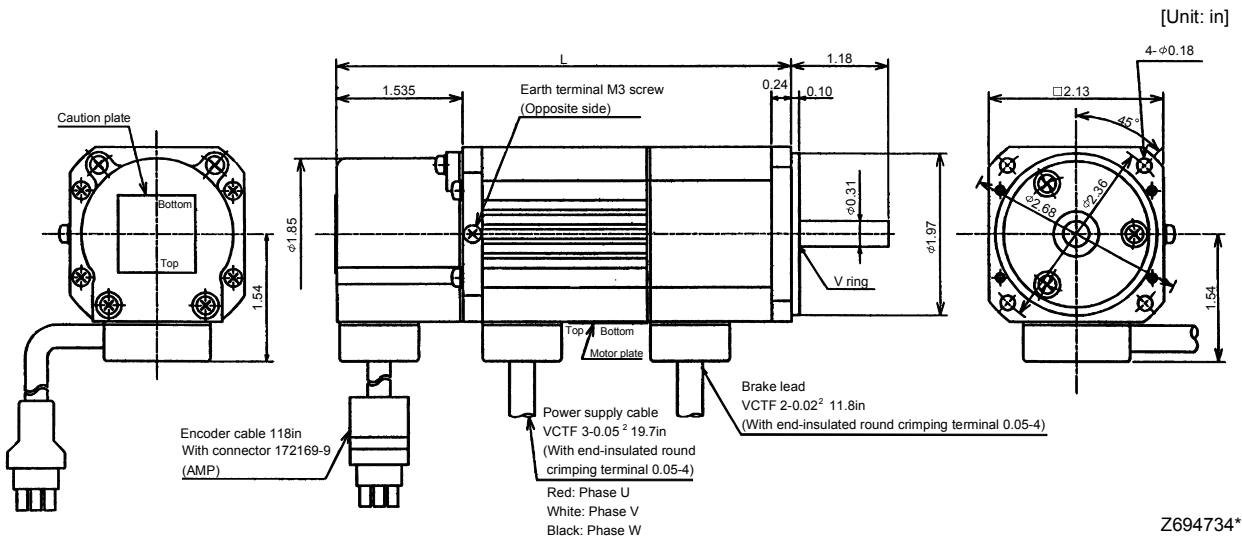

7. OUTLINE DIMENSION DRAWINGS

Model	Output [W]	Variable Dimensions [in]	Brake static friction torque [oz · in]	Inertia Moment WK ² [oz · in ²]	Mass [lb]
		L			
HA-FF23B	200	6.614	170	2.62	6.4
HA-FF33B	300	7.303	170	3.44	7.1

[Unit: in]

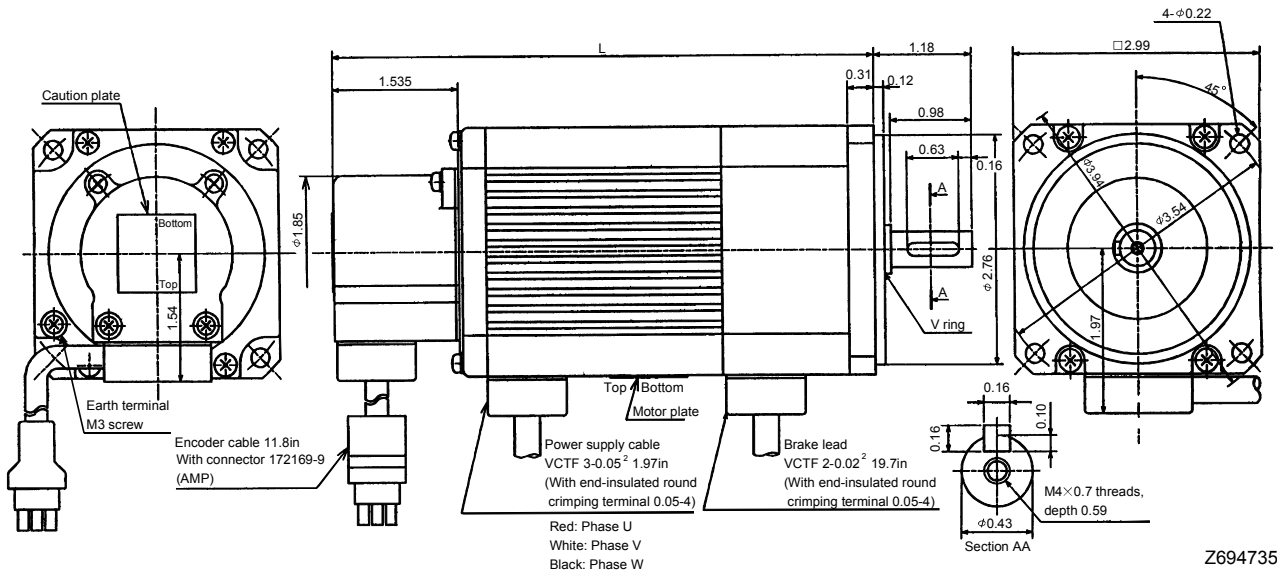

Z694735*

Model	Output [W]	Variable Dimensions [in]	Brake static friction torque [oz · in]	Inertia Moment WK ² [oz · in ²]	Mass [lb]
		L			
HA-FF43B	400	7.54	326	7.27	11.0
HA-FF63B	600	8.13	326	8.48	12.3

[Unit: in]

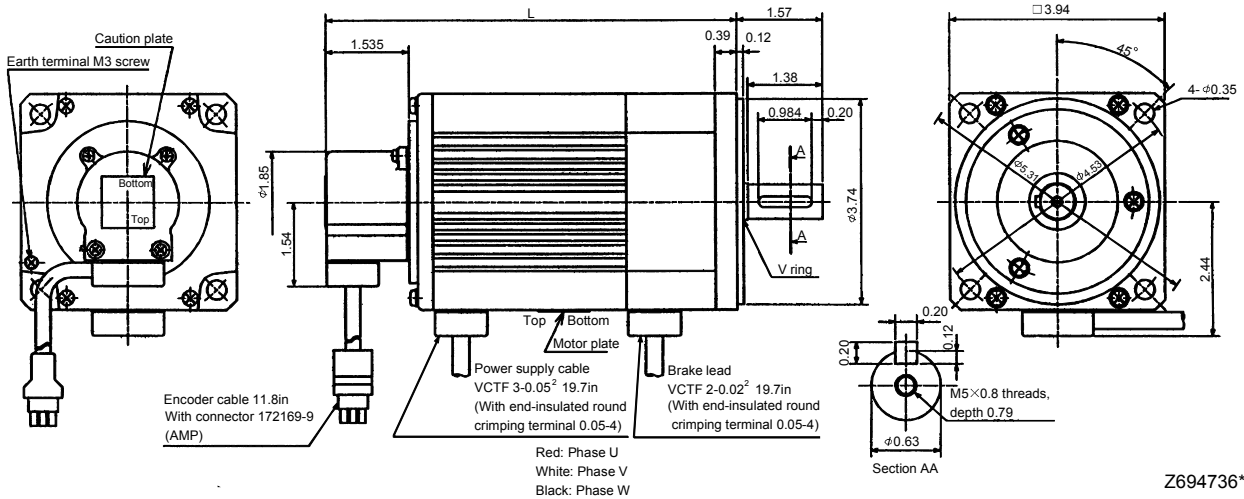

Z694736*

7. OUTLINE DIMENSION DRAWINGS

(3) With reduction gear for general industrial machine

The outer frame of the reduction gear is a material surface such as casting. Its actual dimensions may be 0.039 to 0.118 in larger than the drawing dimensions. Design the machine side with allowances.

(a) Without electromagnetic brake

Model	Output [W]	Reduction Gear Model	Reduction Ratio (Actual Reduction Ratio)	Inertia Moment WK^2 [oz · in ²]	Backlash	Mass [lb]	Output Shaft Rotation Direction
HA-FF053G1	50	GR-S-10	1/5(9/44)	0.369	40min. to 1.5°	5.5	Same as that of motor shaft
			1/10(3/29)				
			1/20(99/1972)	0.342			Opposite to that of motor shaft
			1/30(144/4205)				

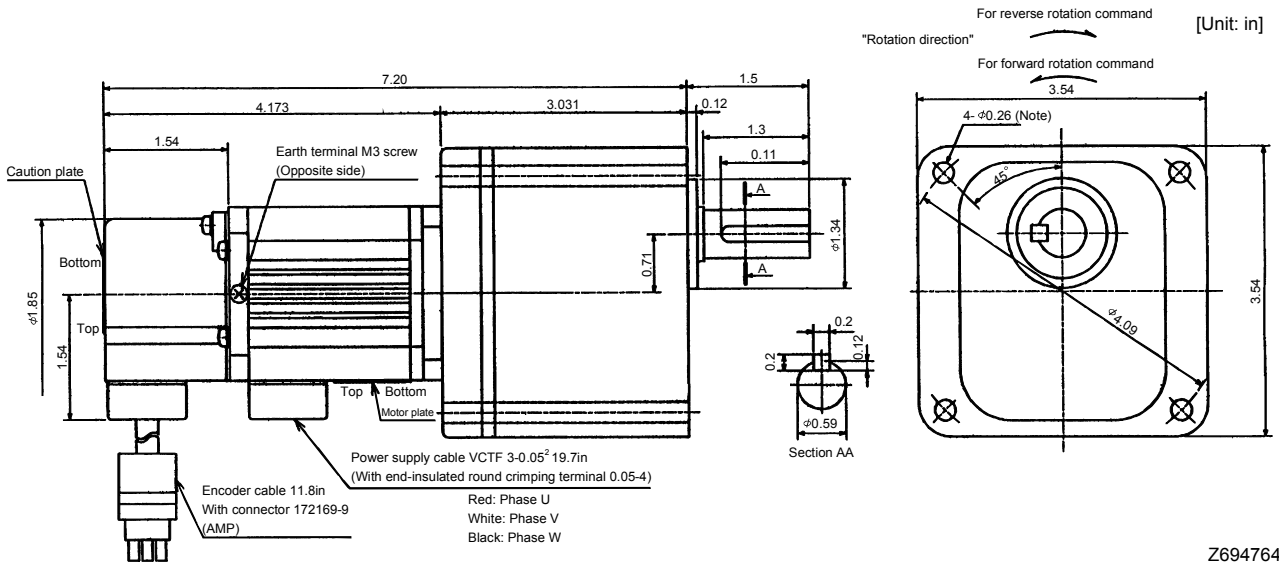

Z694764*

Note: Four M6 × 90 through bolts are provided.

Model	Output [W]	Reduction Gear Model	Reduction Ratio (Actual Reduction Ratio)	Inertia Moment WK^2 [oz · in ²]	Backlash	Mass [lb]	Output Shaft Rotation Direction
HA-FF13G1	100	GR-S-10	1/5(9/44)	0.547	40min. to 1.5°	6.0	Same as that of motor shaft
			1/10(3/29)				
			1/20(99/1972)	0.519			Opposite to that of motor shaft
			1/30(144/4205)				

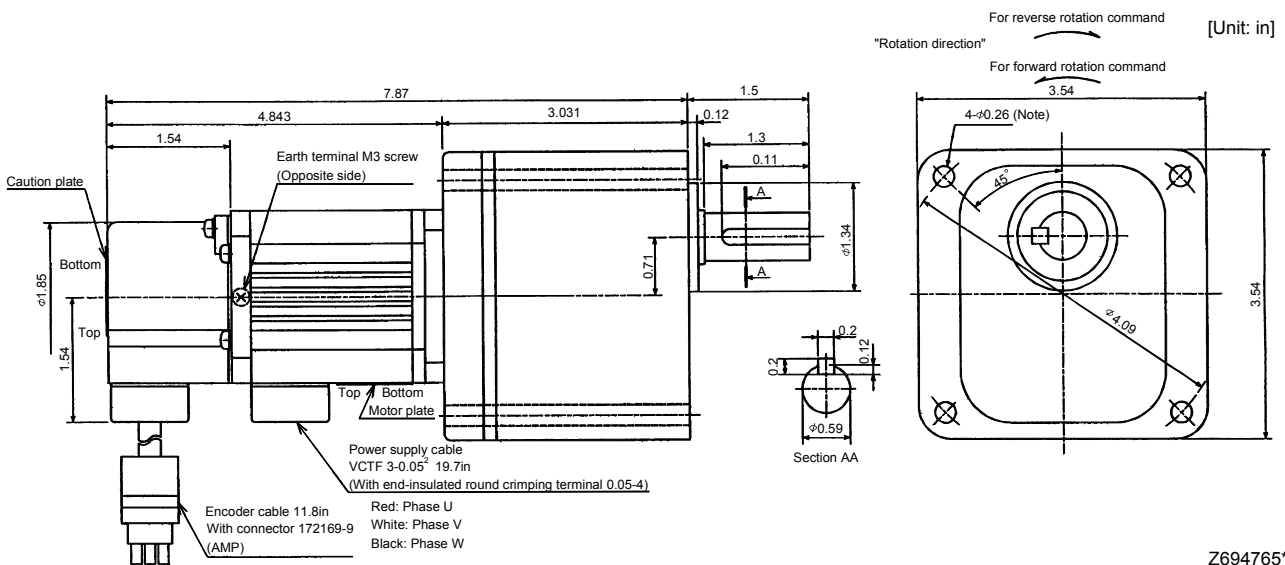

Z694765*

Note: Four M6 × 90 through bolts are provided.

7. OUTLINE DIMENSION DRAWINGS

Model	Output [W]	Reduction Gear Model	Reduction Ratio (Actual Reduction Ratio)	Inertia Moment WK^2 [oz · in ²]	Backlash	Mass [lb]	Output Shaft Rotation Direction
HA-FF23G1	200	GR-S-20	1/5(57/280)	2.039	40min. to 1.5°	11	Same as that of motor shaft
			1/10(39/400)				
			1/20(51/980)	2.023			
			1/30(1/30)				

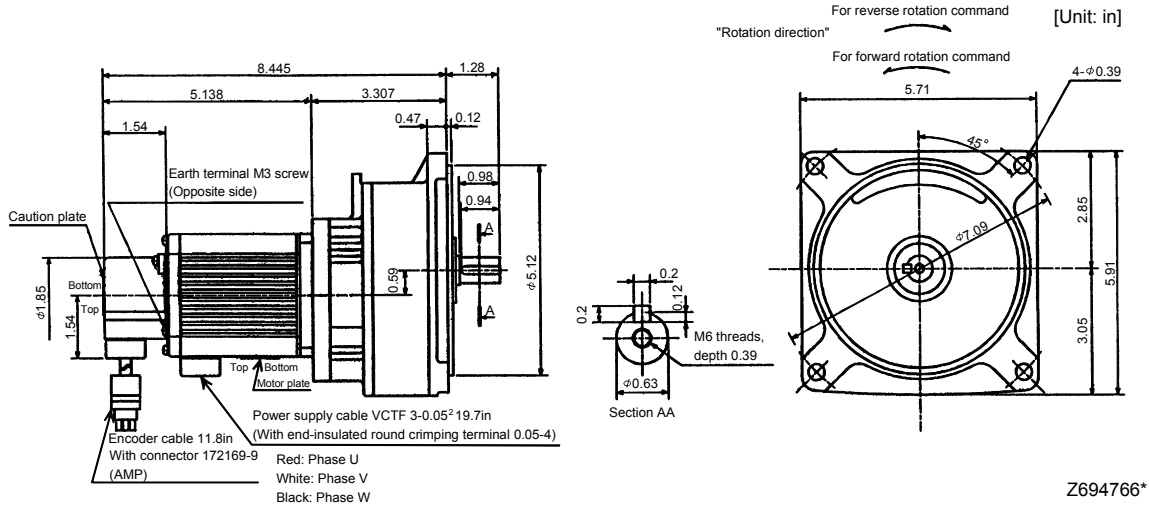

Model	Output [W]	Reduction Gear Model	Reduction Ratio (Actual Reduction Ratio)	Inertia Moment WK^2 [oz · in ²]	Backlash	Mass [lb]	Output Shaft Rotation Direction
HA-FF33G1	300	GR-S-30	1/5(19/94)	2.980	40min. to 1.5°	14.3	Same as that of motor shaft
			1/10(39/376)				
			1/20(72/1363)	2.939			
			1/30(11/329)				

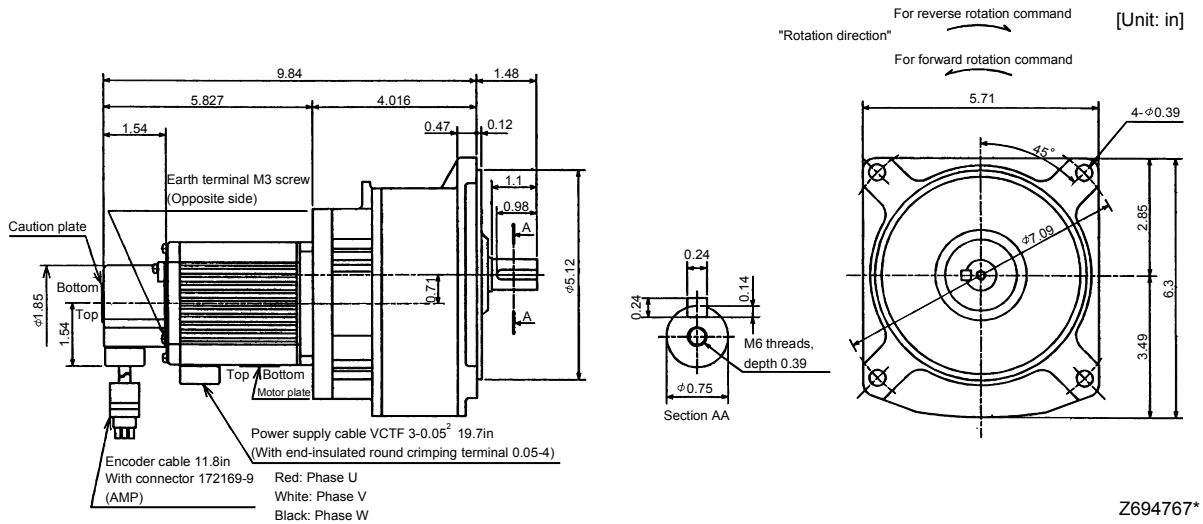

7. OUTLINE DIMENSION DRAWINGS

Model	Output [W]	Reduction Gear Model	Reduction Ratio (Actual Reduction Ratio)	Inertia Moment WK^2 [oz · in ²]	Backlash	Mass [lb]	Output Shaft Rotation Direction
HA-FF43G1	400	GR-S-40	1/5(19/94)	5.577	40min. to 1.5°	17.6	Same as that of motor shaft
			1/10(39/376)				
			1/20(72/1363)	5.536			
			1/30(11/329)				

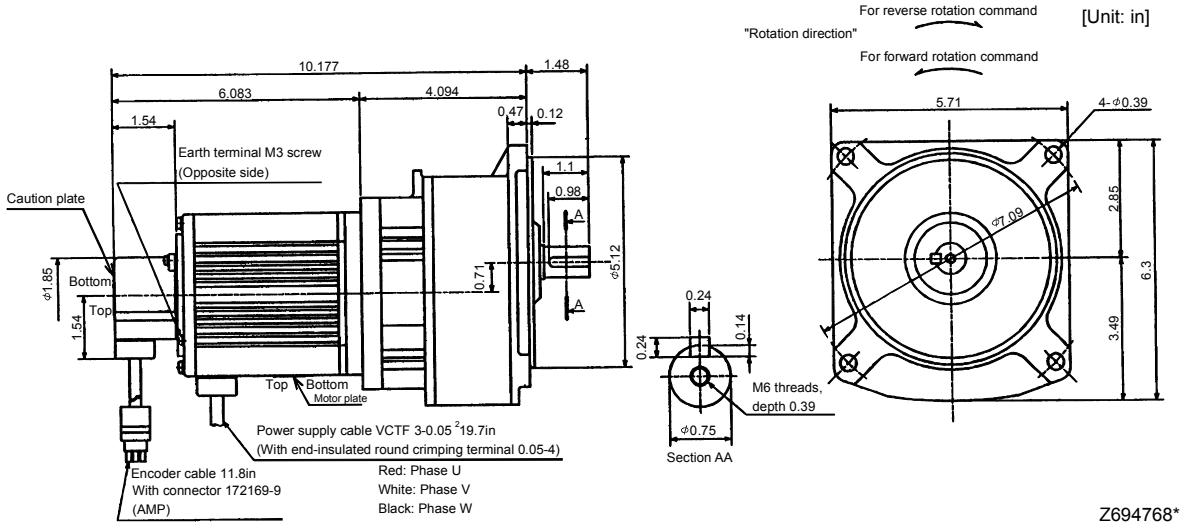

Z694768*

Model	Output [W]	Reduction Gear Model	Reduction Ratio (Actual Reduction Ratio)	Inertia Moment WK^2 [oz · in ²]	Backlash	Mass [lb]	Output Shaft Rotation Direction
HA-FF63G1	600	GR-S-60	1/5(10/49)	7.326	40min. to 1.5°	28.7	Same as that of motor shaft
			1/10(243/2401)				
			1/20(153/2891)	7.217			
			1/30(27/784)				

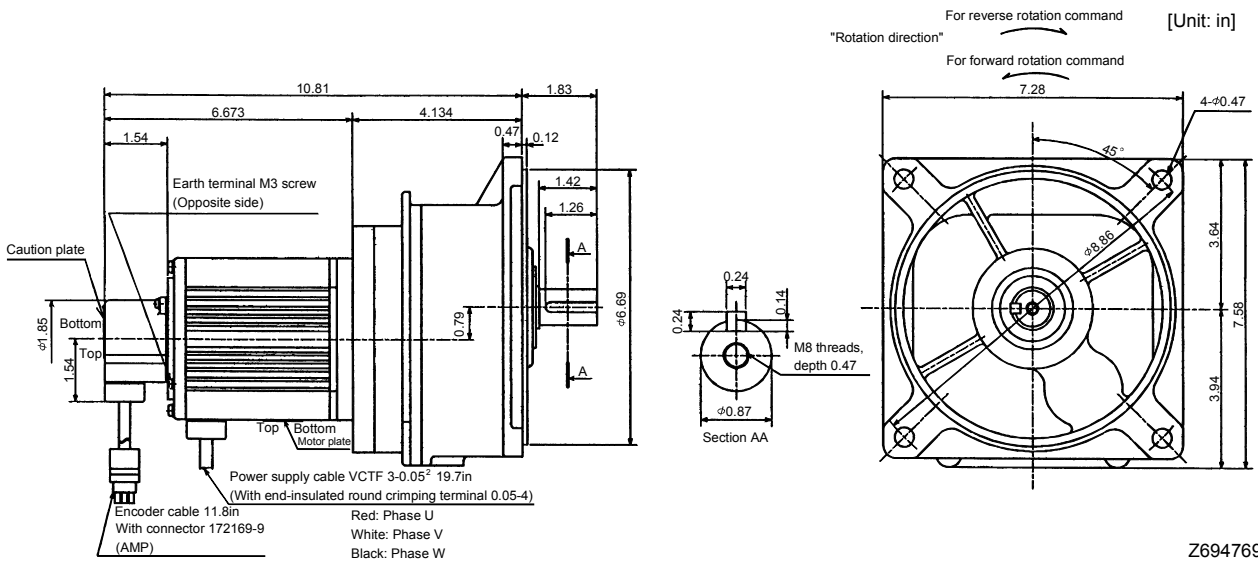

Z694769*

7. OUTLINE DIMENSION DRAWINGS

(b) With electromagnetic brake

Model	Output [W]	Brake static friction torque [oz · in]	Reduction Gear Model	Reduction Ratio (Actual Reduction Ratio)	Inertia Moment WK^2 [oz · in ²]	Backlash	Mass [lb]	Output Shaft Rotation Direction
HA-FF053BG1	50	55	GR-S-10	1/5(9/44)	0.465	40min. to 1.5°	6.2	Same as that of motor shaft
				1/10(3/29)				
				1/20(99/1972)	0.437			Opposite to that of motor shaft
				1/30(144/4205)				

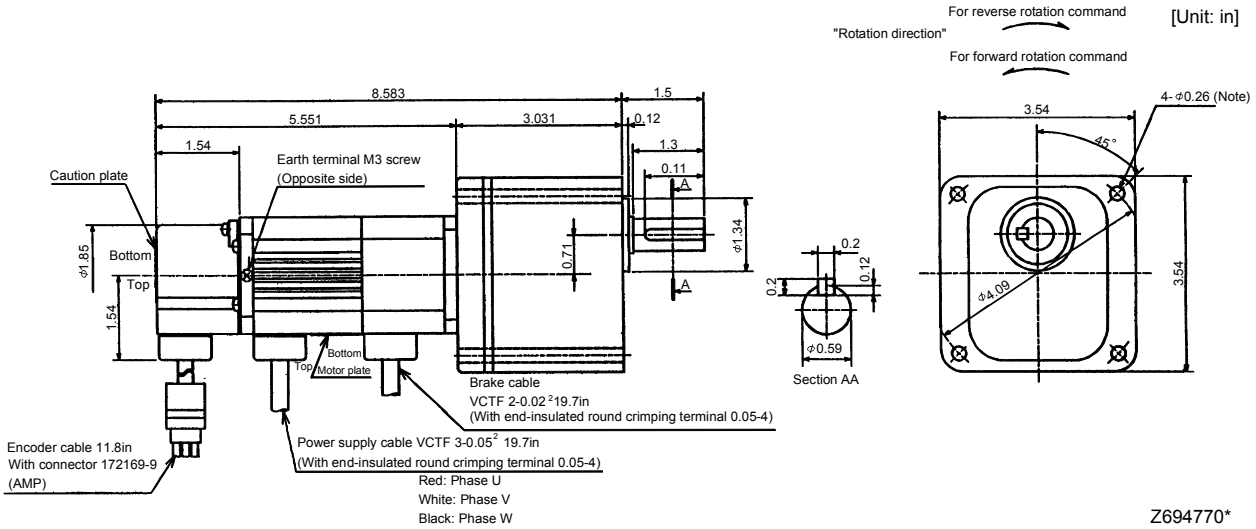

Note: Four M6 × 90 through bolts are provided.

Model	Output [W]	Brake static friction torque [oz · in]	Reduction Gear Model	Reduction Ratio (Actual Reduction Ratio)	Inertia Moment WK^2 [oz · in ²]	Backlash	Mass [lb]	Output Shaft Rotation Direction
HA-FF13BG1	100	55	GR-S-10	1/5(9/44)	0.629	40min. to 1.5°	6.6	Same as that of motor shaft
				1/10(3/29)				
				1/20(99/1972)	0.601			Opposite to that of motor shaft
				1/30(144/4205)				

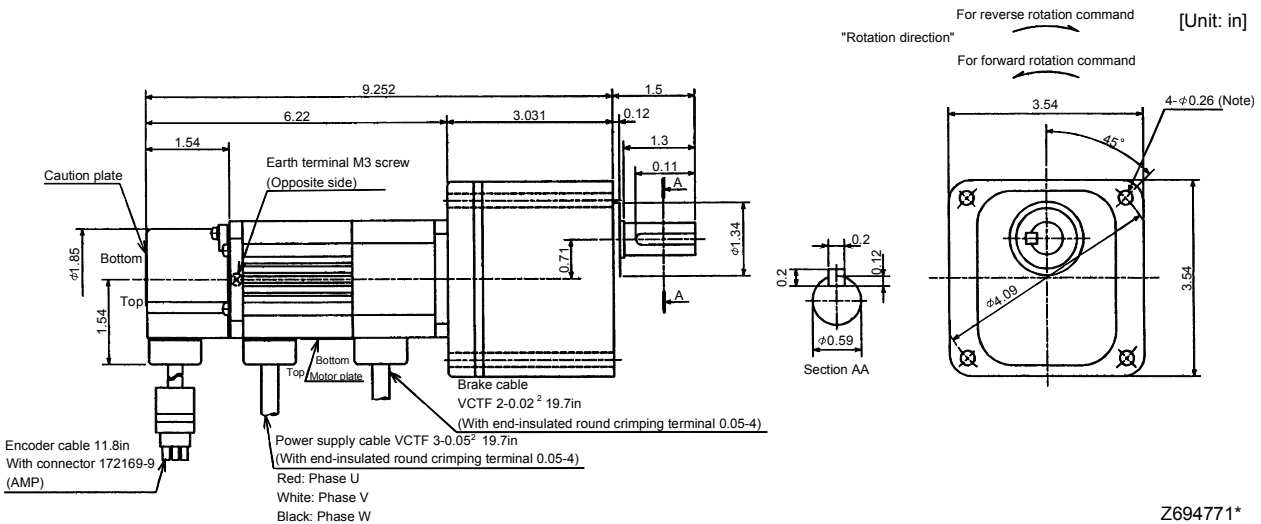

Note: Four M6 × 90 through bolts are provided.

7. OUTLINE DIMENSION DRAWINGS

Model	Output [W]	Brake static friction torque [oz · in]	Reduction Gear Model	Reduction Ratio (Actual Reduction Ratio)	Inertia Moment WK ² [oz · in ²]	Backlash	Mass [lb]	Output Shaft Rotation Direction
HA-FF23BG1	200	170	GR-S-20	1/5(57/280)	2.75	40min. to 1.5°	12.3	Same as that of motor shaft
				1/10(39/400)				
				1/20(51/980)	2.734			
				1/30(1/30)				

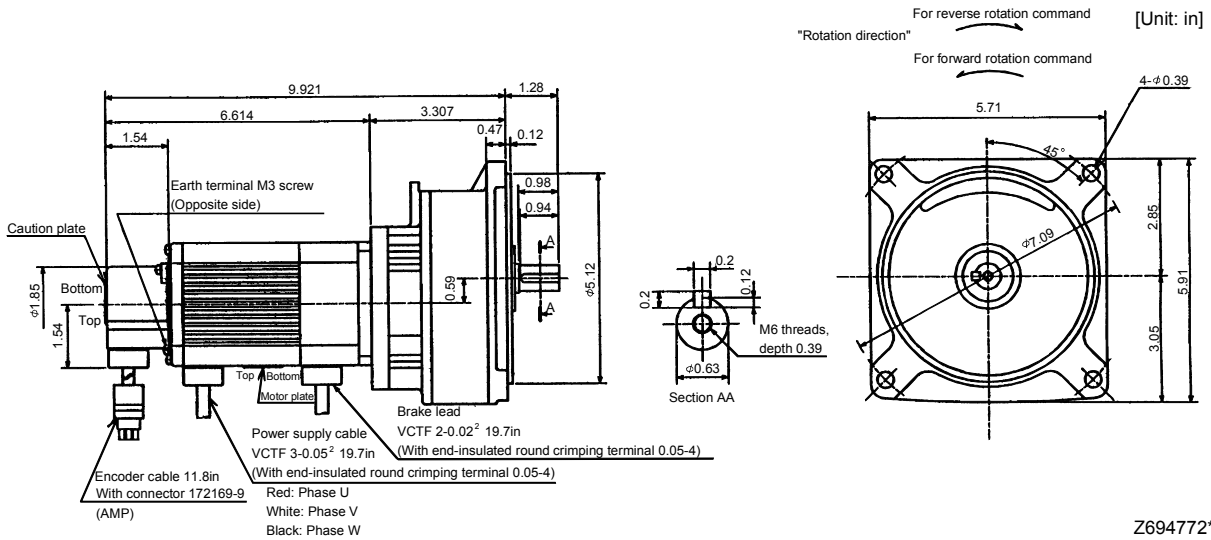

Model	Output [W]	Brake static friction torque [oz · in]	Reduction Gear Model	Reduction Ratio (Actual Reduction Ratio)	Inertia Moment WK ² [oz · in ²]	Backlash	Mass [lb]	Output Shaft Rotation Direction
HA-FF33BG1	300	170	GR-S-30	1/5(19/94)	3.707	40min. to 1.5°	15.9	Same as that of motor shaft
				1/10(39/376)				
				1/20(72/1363)	3.663			
				1/30(11/329)				

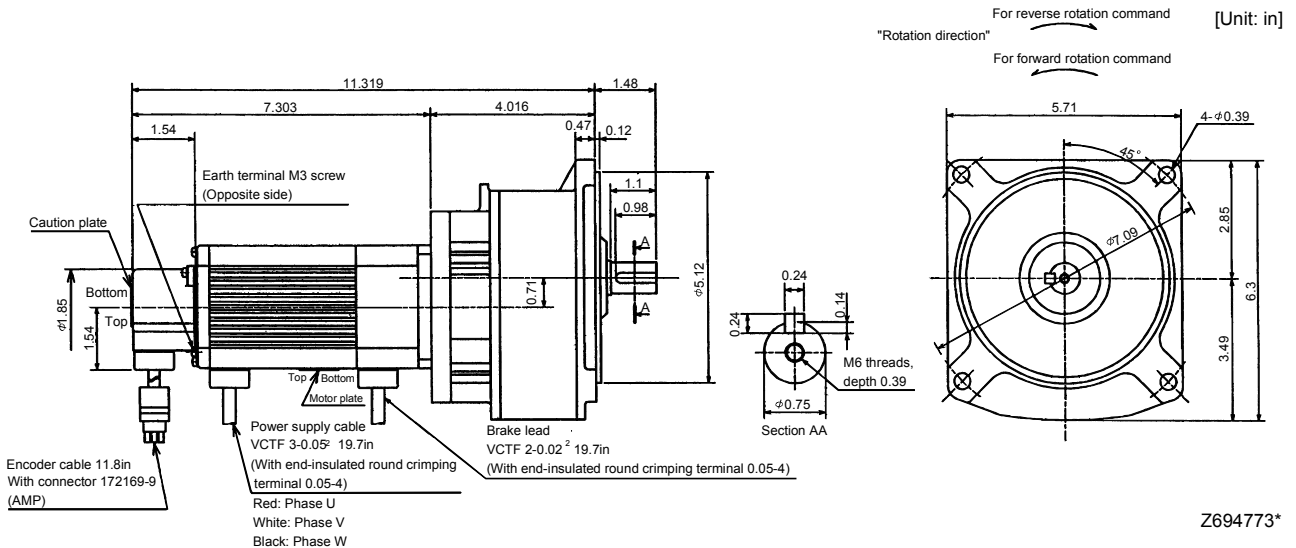

7. OUTLINE DIMENSION DRAWINGS

Model	Output [W]	Brake static friction torque [oz · in]	Reduction Gear Model	Reduction Ratio (Actual Reduction Ratio)	Inertia Moment WK ² [oz · in ²]	Backlash	Mass [lb]	Output Shaft Rotation Direction
HA-FF43BG1	400	326	GR-S-40	1/5(19/94)	7.490	40min. to 1.5°	19.6	Same as that of motor shaft
				1/10(39/376)				
				1/20(72/1363)	7.449			
				1/30(11/329)				

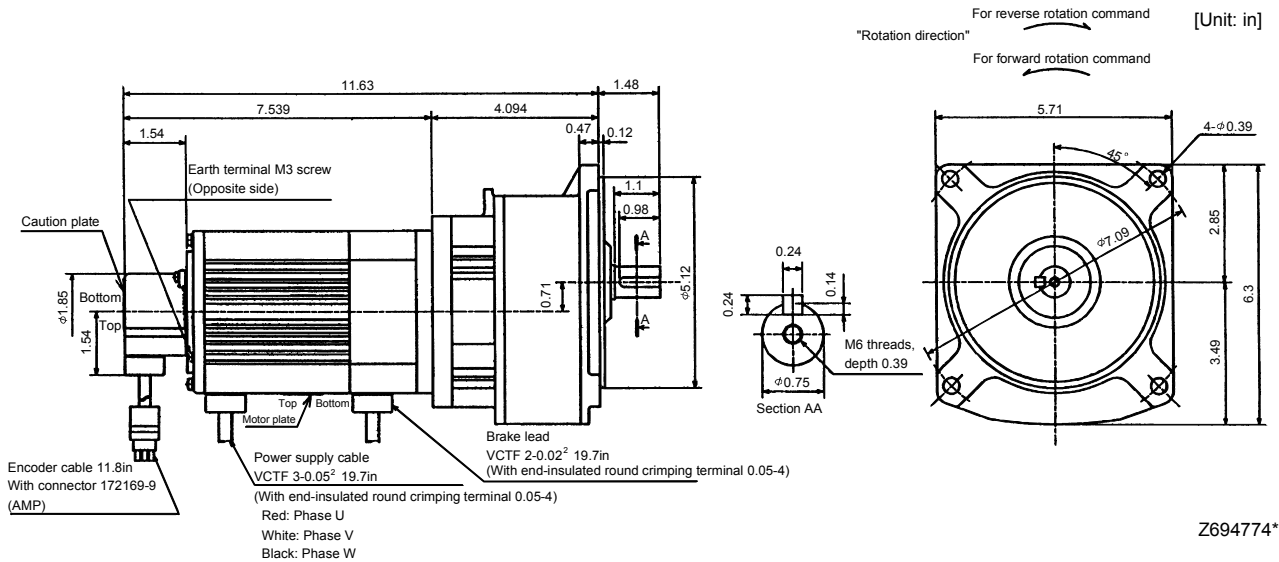

Model	Output [W]	Brake static friction torque [oz · in]	Reduction Gear Model	Reduction Ratio (Actual Reduction Ratio)	Inertia Moment WK ² [oz · in ²]	Backlash	Mass [lb]	Output Shaft Rotation Direction
HA-FF63BG1	600	326	GR-S-60	1/5(10/49)	9.240	40min. to 1.5°	30.6	Same as that of motor shaft
				1/10(243/2401)				
				1/20(153/2891)	9.131			
				1/30(27/784)				

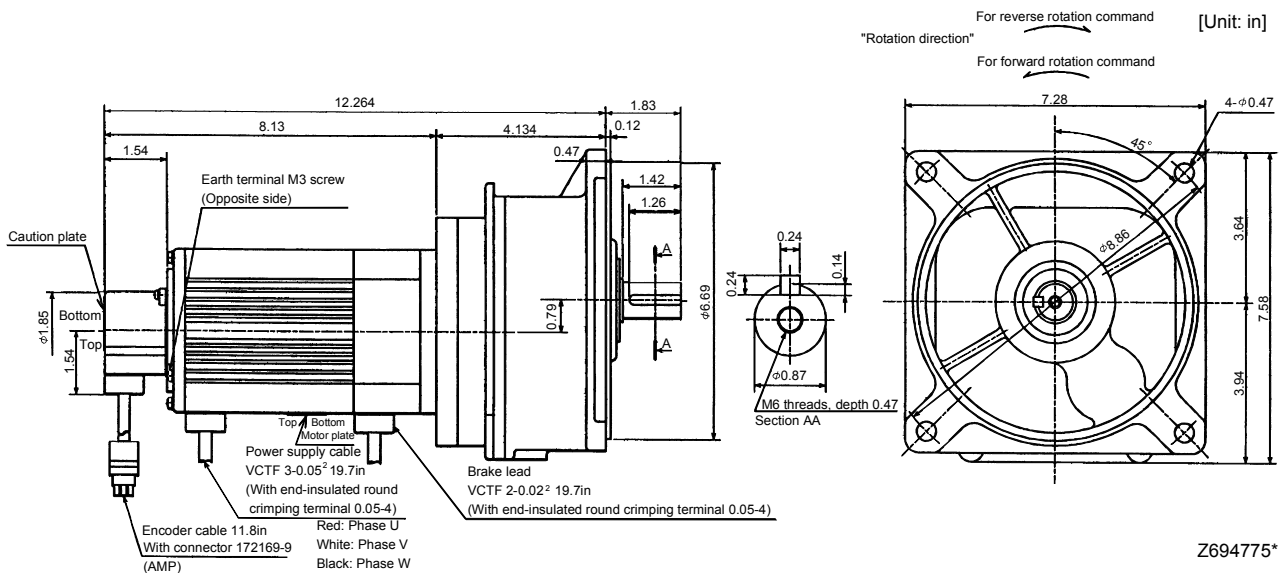

7. OUTLINE DIMENSION DRAWINGS

(4) With reduction gear for precision application

The outer frame of the reduction gear is a material surface such as casting. Its actual dimensions may be 0.039 to 0.118 in larger than the drawing dimensions. Design the machine side with allowances.

(a) Without electromagnetic brake

Model	Output [W]	Reduction Gear Model	Reduction Ratio	Inertia Moment WK ² [oz · in ²]	Backlash	Mass [lb]
HA-FF053G2	50	BM2-05B-A5MES	1/5	0.60	3 min. max.	5.1

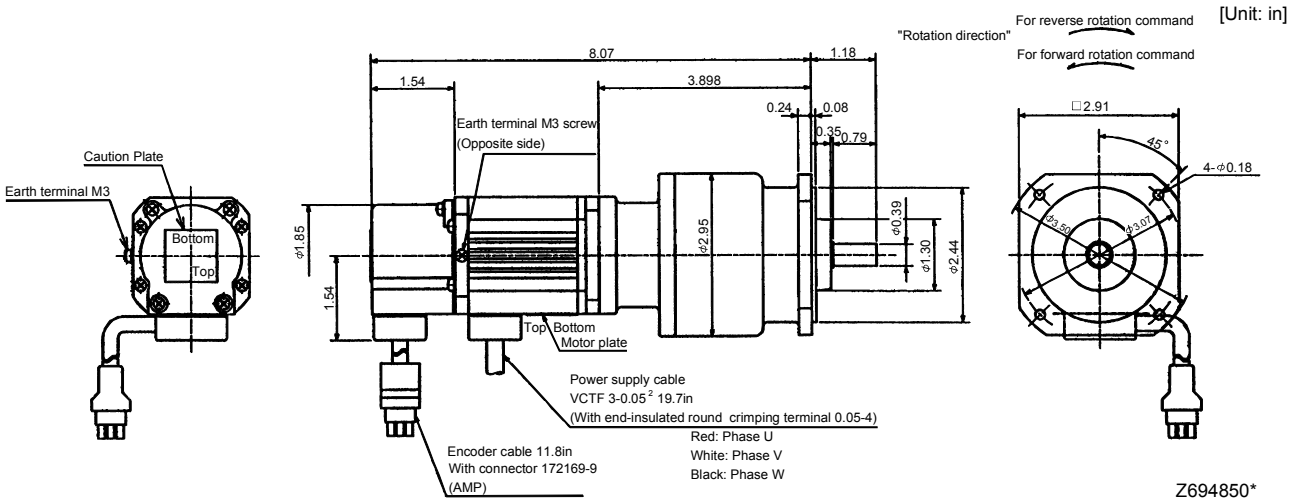

Model	Output [W]	Variable Dimensions [in]		Reduction Gear Model	Reduction Ratio	Inertia Moment WK ² [oz · in ²]	Backlash	Mass [lb]
		L						
HA-FF053G2	50	8.07		BM2-10B-A5MES	1/10	0.59	3 min. max.	5.1
HA-FF053G2	50	8.07		BM2-15B-A5MES	1/15	0.57	3 min. max.	5.1
HA-FF13G2	100	8.74		BM2-05B-01MES	1/5	0.78	3 min. max.	5.5

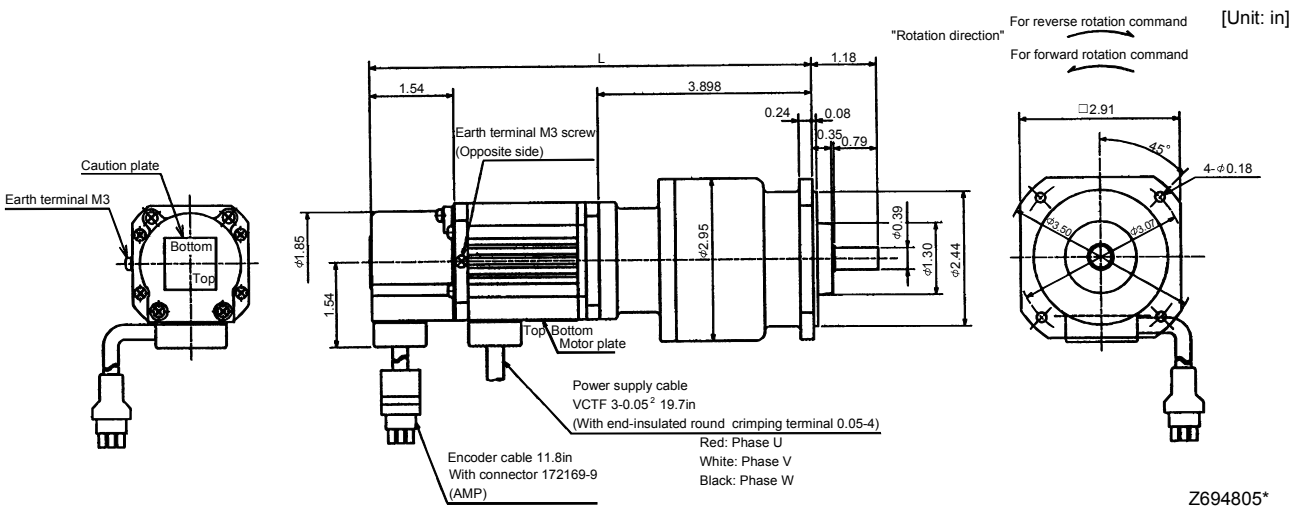

7. OUTLINE DIMENSION DRAWINGS

Model	Output [W]	Variable Dimensions [in]	Reduction Gear Model	Reduction Ratio	Inertia Moment WK^2 [oz · in ²]	Backlash	Mass [lb]
		L					
HA-FF053G2	50	8.39	BM3-25B-A5MES	1/25	0.601	3min. max.	6.2
HA-FF13G2	100	9.06	BM3-10B-01MES	1/10	0.90	3min. max.	6.6
HA-FF13G2	100	9.06	BM3-15B-01MES	1/15	0.85	3min. max.	6.6

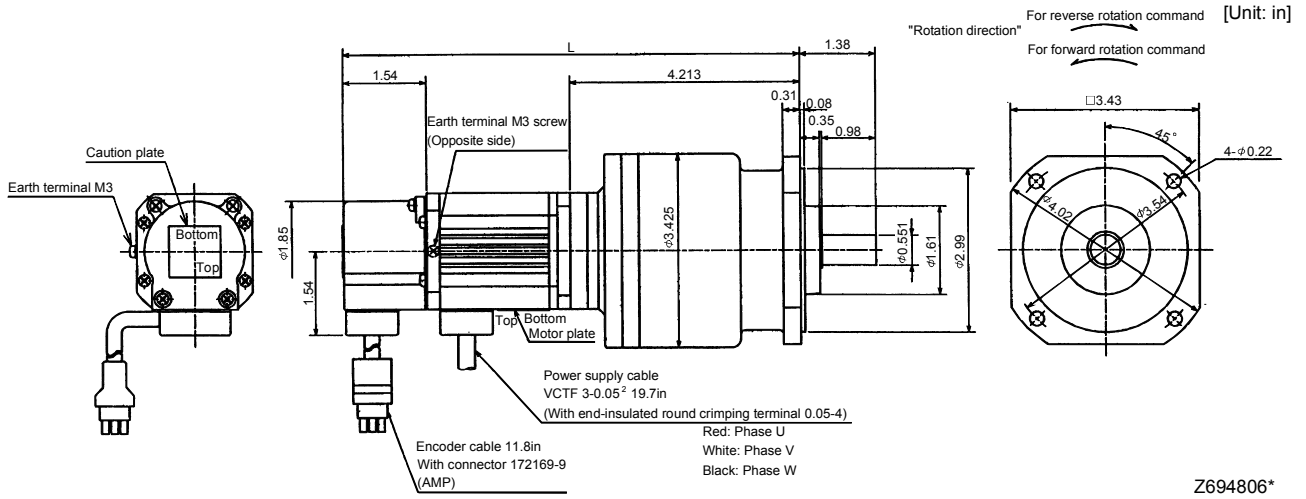

Model	Output [W]	Reduction Gear Model	Reduction Ratio	Inertia Moment WK^2 [oz · in ²]	Backlash	Mass [lb]
HA-FF13G2	100	BM4-25B-01MES	1/25	1.59	3min. max.	11.0

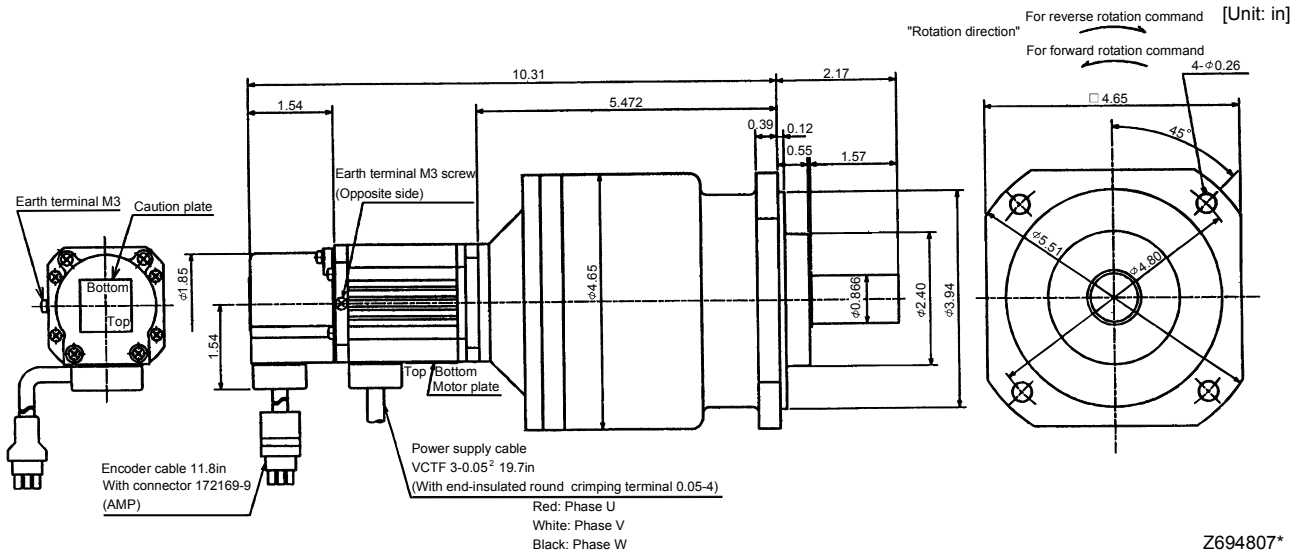

7. OUTLINE DIMENSION DRAWINGS

Model	Output [W]	Reduction Gear Model	Reduction Ratio	Inertia Moment WK^2 [oz · in ²]	Backlash	Mass [lb]
HA-FF13G2	100	BL1-45B-01MES	1/45	1.60	3min. max.	13.2

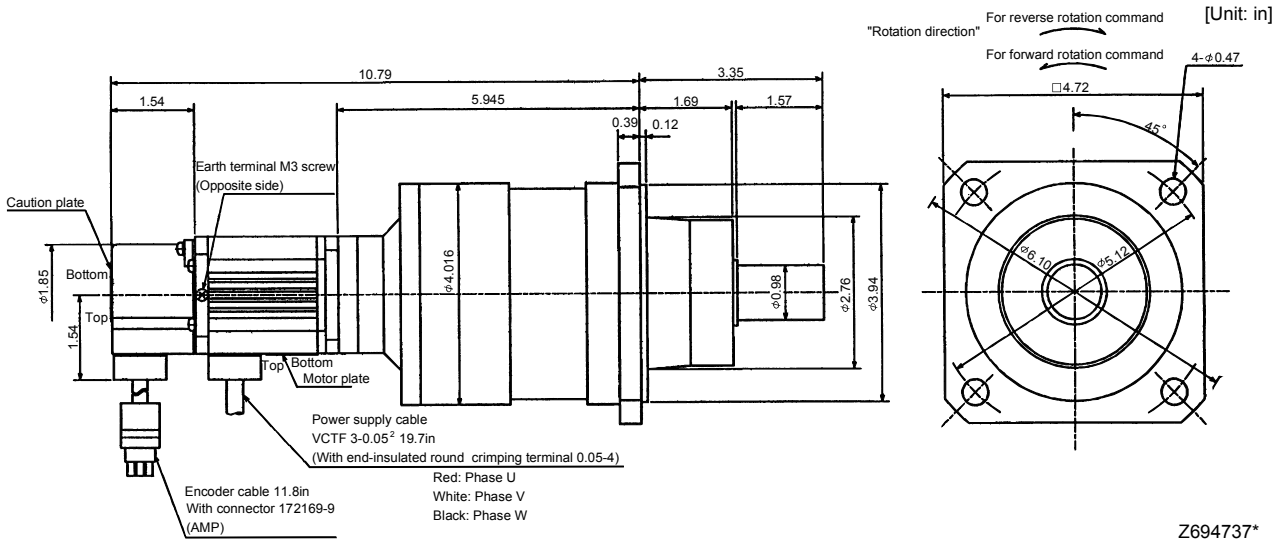

Model	Output [W]	Reduction Gear Model	Reduction Ratio	Inertia Moment WK^2 [oz · in ²]	Backlash	Mass [lb]
HA-FF23G2	200	BM3-05B-02MES	1/5	2.32	3min. max.	8.4

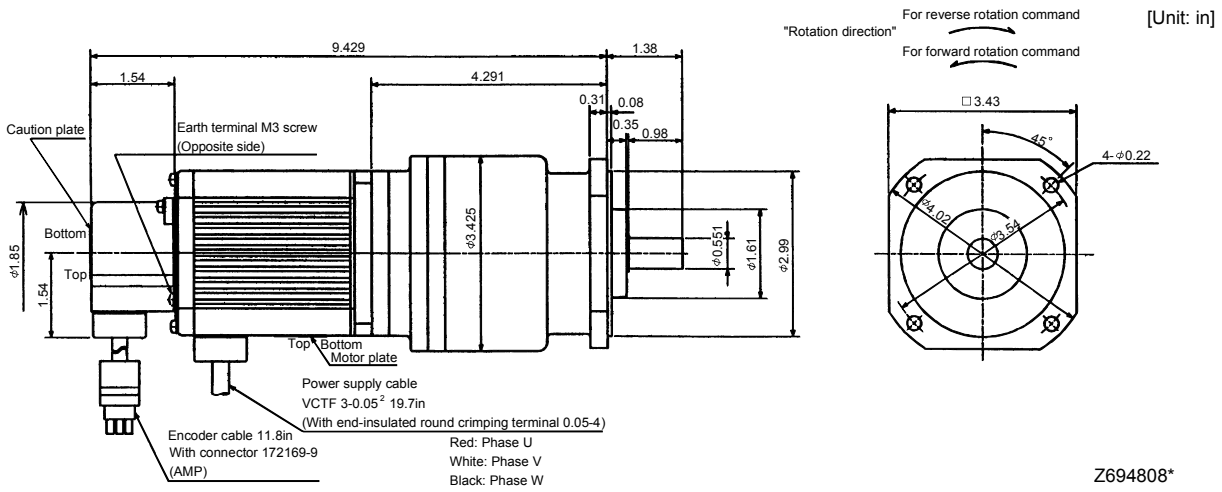

7. OUTLINE DIMENSION DRAWINGS

Model	Output [W]	Variable Dimensions [in]	Reduction Gear Model	Reduction Ratio	Inertia Moment WK^2 [oz · in ²]	Backlash	Mass [lb]
		L					
HA-FF23G2	200	10.61	BM4-10B-02MES	1/10	3.53	3min. max.	12.8
HA-FF23G2	200	10.61	BM4-15B-02MES	1/15	3.38	3min. max.	12.8
HA-FF33G2	300	11.30	BM4-10B-03MES	1/10	4.35	3min. max.	13.4

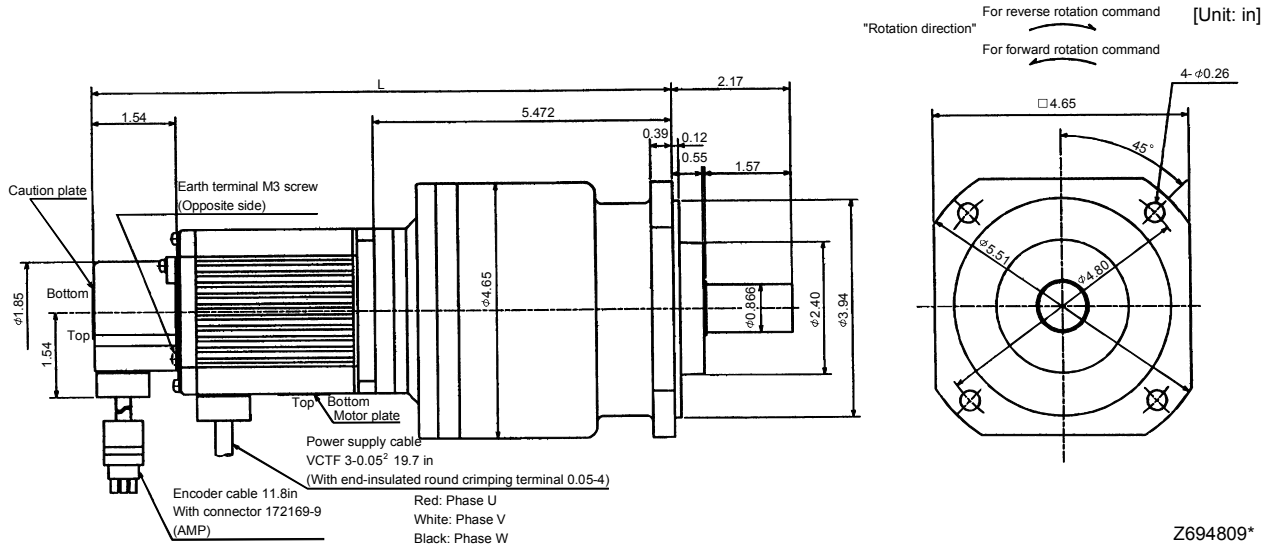

Model	Output [W]	Variable Dimensions [in]	Reduction Gear Model	Reduction Ratio	Inertia Moment WK^2 [oz · in ²]	Backlash	Mass [lb]
		L					
HA-FF23G2	200	10.94	BL1-20B-02MES	1/20	3.99	3min. max.	15.0
HA-FF23G2	200	10.94	BL1-29B-02MES	1/29	3.46	3min. max.	15.0
HA-FF33G2	300	11.61	BL1-20B-03MES	1/20	4.81	3min. max.	15.7

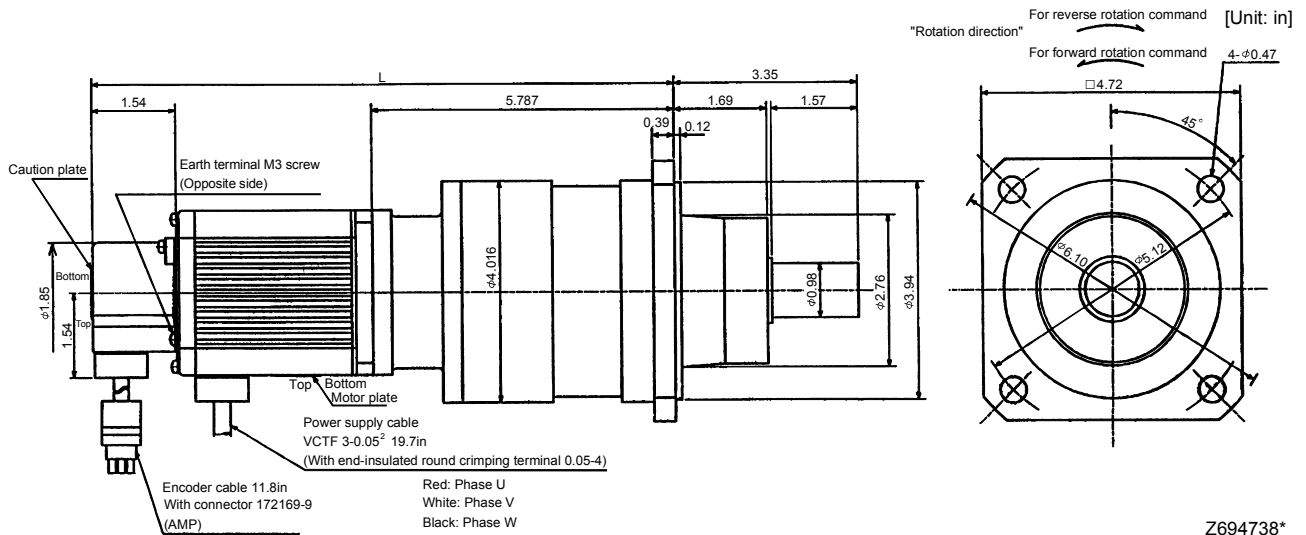

7. OUTLINE DIMENSION DRAWINGS

Model	Output [W]	Variable Dimensions [in]		Reduction Gear Model	Reduction Ratio	Inertia Moment WK^2 [oz · in ²]	Backlash	Mass [lb]
		L						
HA-FF23G2	200	11.77		BL2-45B-02MES	1/45	4.17	3min. max.	27.1
HA-FF33G2	300	12.44		BL2-29B-03MES	1/29	83.9	3min. max.	27.8
HA-FF33G2	300	12.44		BL2-45B-03MES	1/45	4.99	3min. max.	27.8

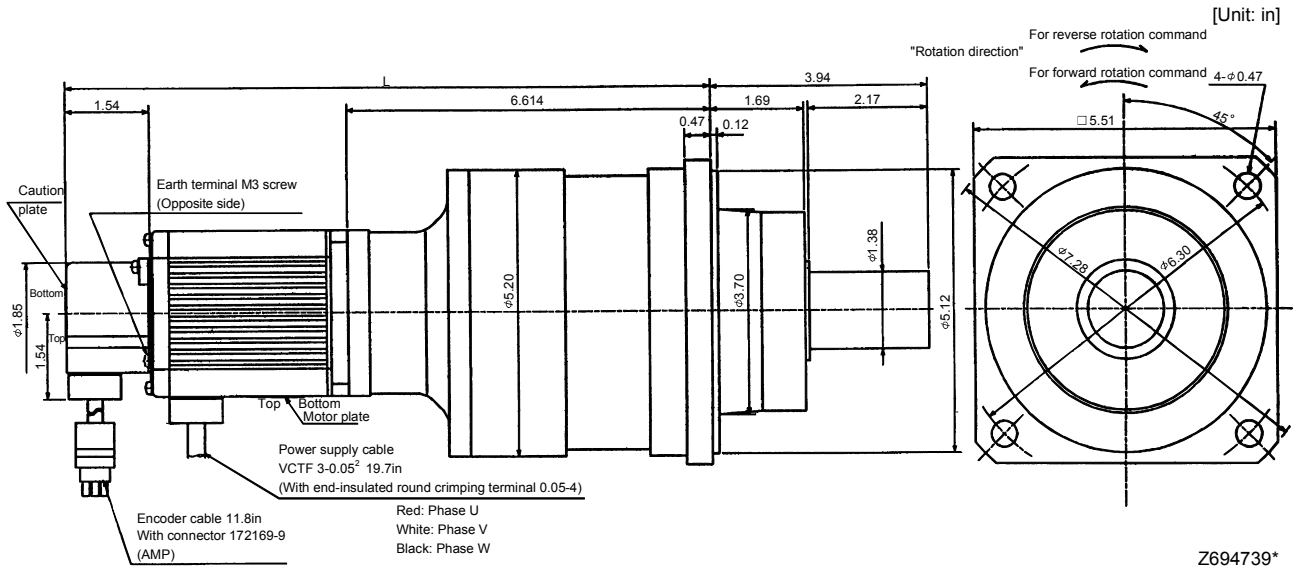

Model	Output [W]	Reduction Gear Model	Reduction Ratio	Inertia Moment WK^2 [oz · in ²]	Backlash	Mass [lb]
HA-FF33G2	300	BM4-05B-03MES	1/5	4.47	3min. max.	13.4

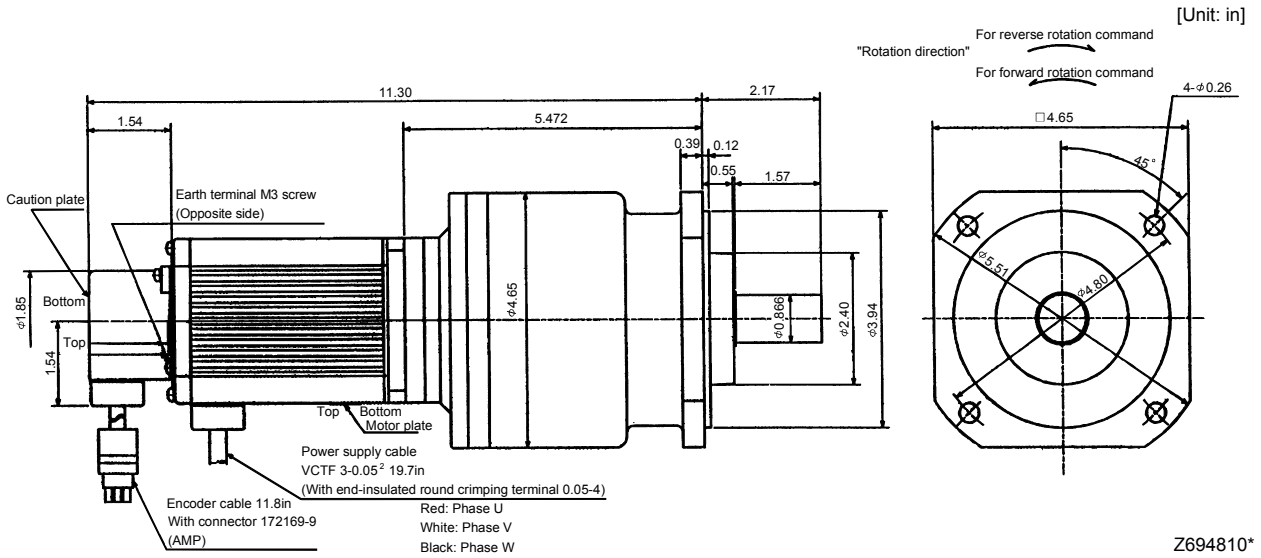

7. OUTLINE DIMENSION DRAWINGS

Model	Output [W]	Reduction Gear Model	Reduction Ratio	Inertia Moment WK^2 [oz · in ²]	Backlash	Mass [lb]
HA-FF43G2	400	BM4-05B-04MES	1/5	7.07	3min. max.	17.0

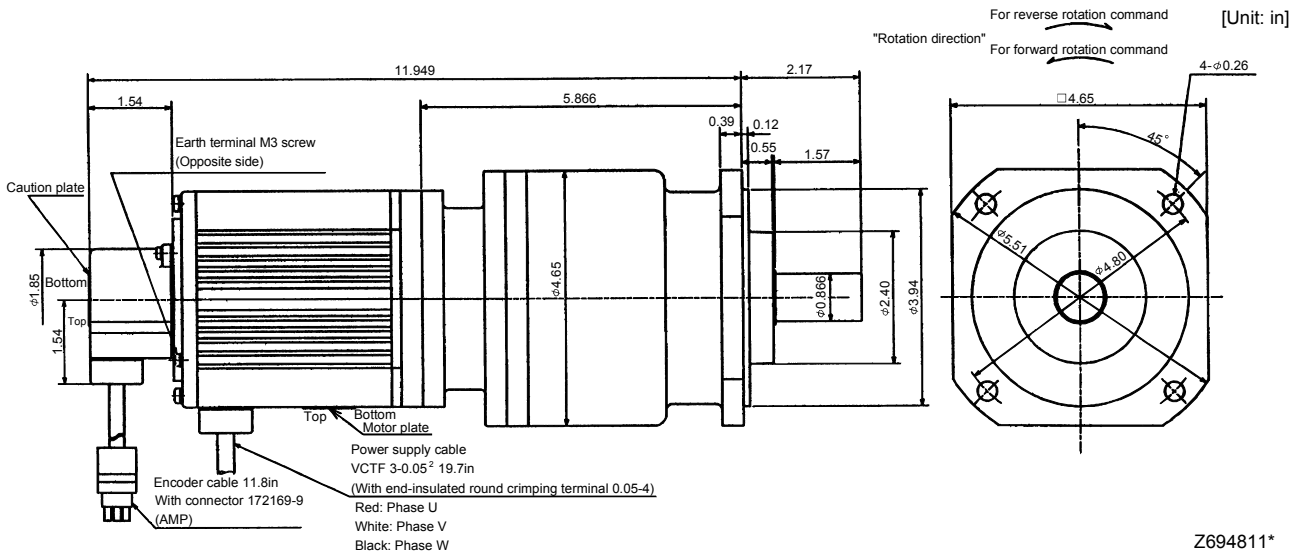

Model	Output [W]	Variable Dimensions [in]		Reduction Gear Model	Reduction Ratio	Inertia Moment WK^2 [oz · in ²]	Backlash	Mass [lb]
		L	H					
HA-FF43G2	400	11.63	5.557	BL1-09B-04MES	1/9	6.52	3min. max.	18.1
HA-FF63G2	600	11.83	5.157	BL1-05B-06MES	1/5	7.01	3min. max.	19.4
HA-FF63G2	600	12.22	5.557	BL1-09B-06MES	1/9	7.75	3min. max.	19.4

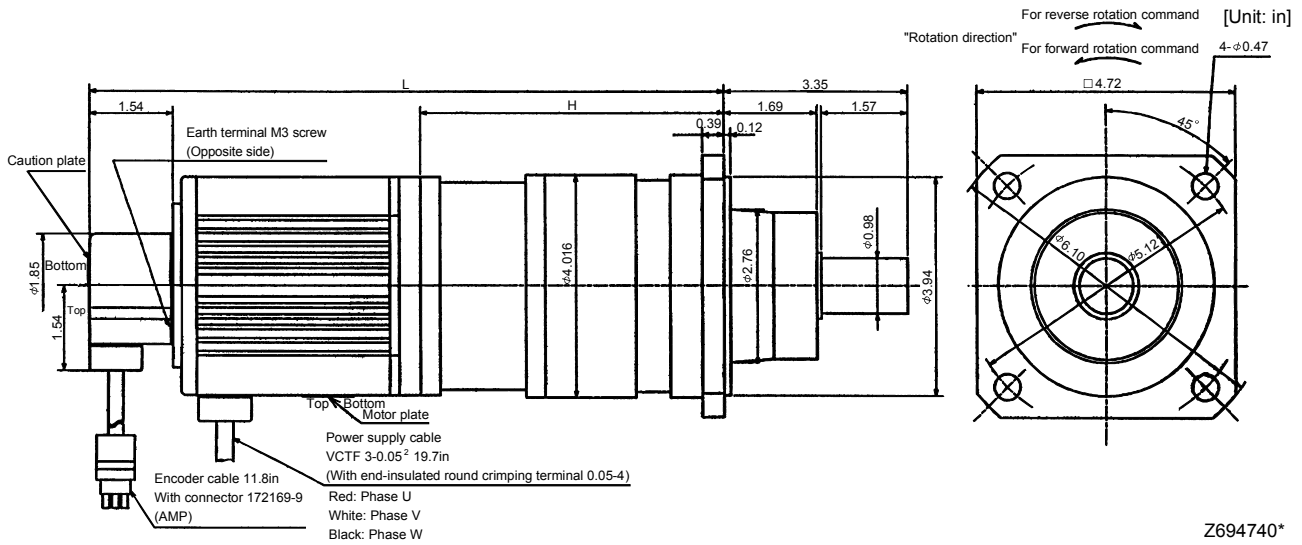

7. OUTLINE DIMENSION DRAWINGS

Model	Output [W]	Variable Dimensions [in]		Reduction Gear Model	Reduction Ratio	Inertia Moment WK^2 [oz · in ²]	Backlash	Mass [lb]
		L	H					
HA-FF43G2	400	12.74	6.654	BL2-20B-04MES	1/20	13.00	3min. max	31.3
HA-FF43G2	400	12.74	6.654	BL2-29B-04MES	1/29	10.99	3min. max	31.3
HA-FF43G2	400	13.13	7.047	BL2-45B-04MES	1/45	7.59	3min. max	31.3
HA-FF63G2	600	13.33	6.654	BL2-20B-06MES	1/20	14.23	3min. max	32.6
HA-FF63G2	600	13.33	6.654	BL2-29B-06MES	1/29	12.22	3min. max	32.6

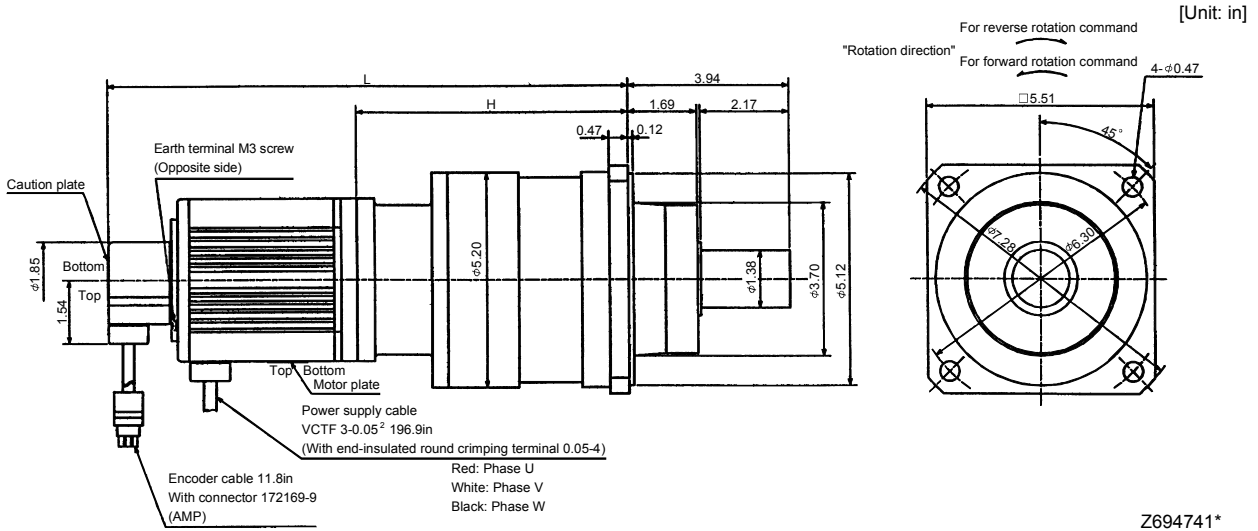

Model	Output [W]	Reduction Gear Model	Reduction Ratio	Inertia Moment WK^2 [oz · in ²]	Backlash	Mass [lb]
HA-FF63G2	600	BL3-45B-06MES	1/45	17.11	3min. max.	65.7

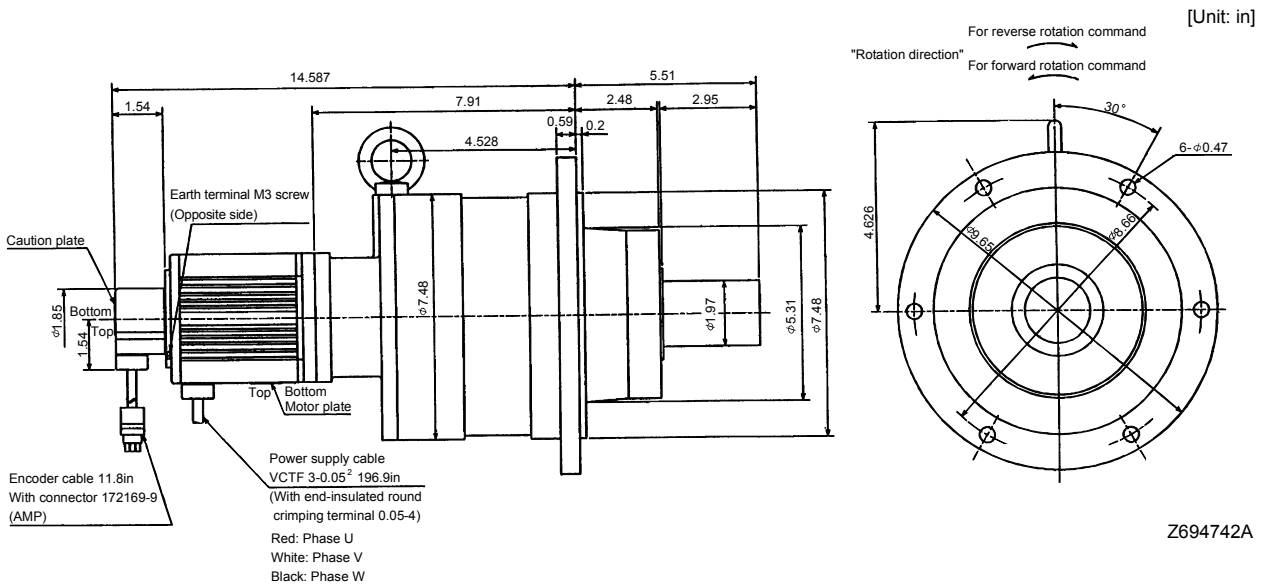

7. OUTLINE DIMENSION DRAWINGS

(b) With electromagnetic brake

Model	Output [W]	Brake static friction torque [oz · in]	Reduction Gear Model	Reduction Ratio	Inertia Moment WK ² [oz · in ²]	Backlash	Mass [lb]
HA-FF053BG2	50	55	BM2-05B-A5MES	1/5	0.70	3min. max.	5.7

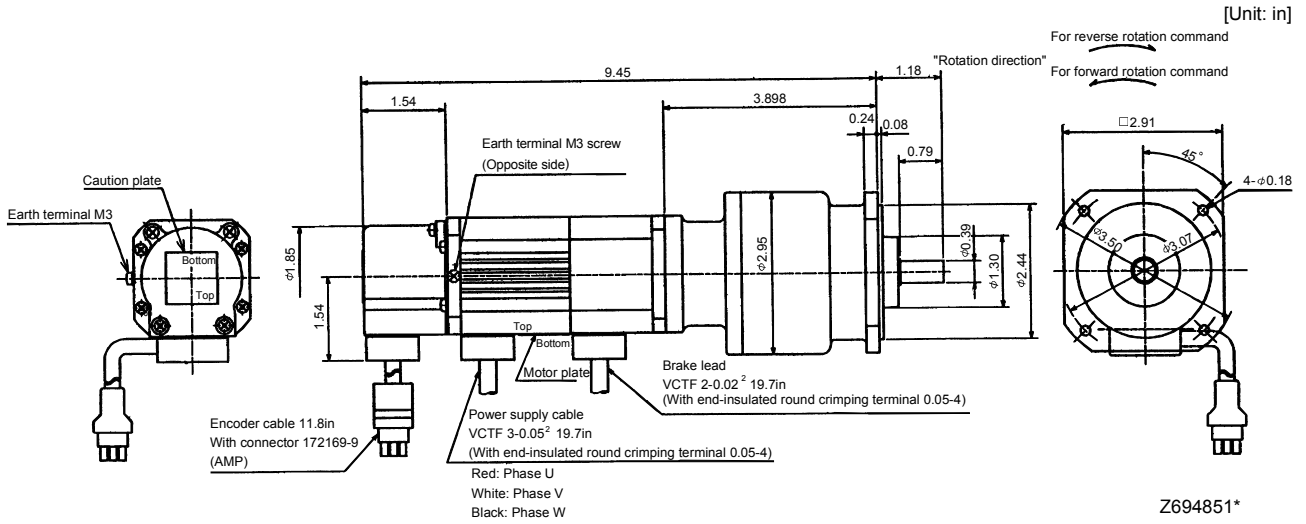

Model	Output [W]	Variable Dimensions [in]	Brake static friction torque [oz · in]	Reduction Gear Model	Reduction Ratio	Inertia Moment WK ² [oz · in ²]	Backlash	Mass [lb]
		L						
HA-FF053BG2	50	9.45	55	BM2-05B-A5MES	1/10	0.68	3 min. max.	5.7
HA-FF053BG2	50	9.45	55	BM2-15B-A5MES	1/15	0.67	3 min. max.	5.7
HA-FF13BG2	100	10.118	55	BM2-05B-01MES	1/5	0.87	3 min. max.	6.2

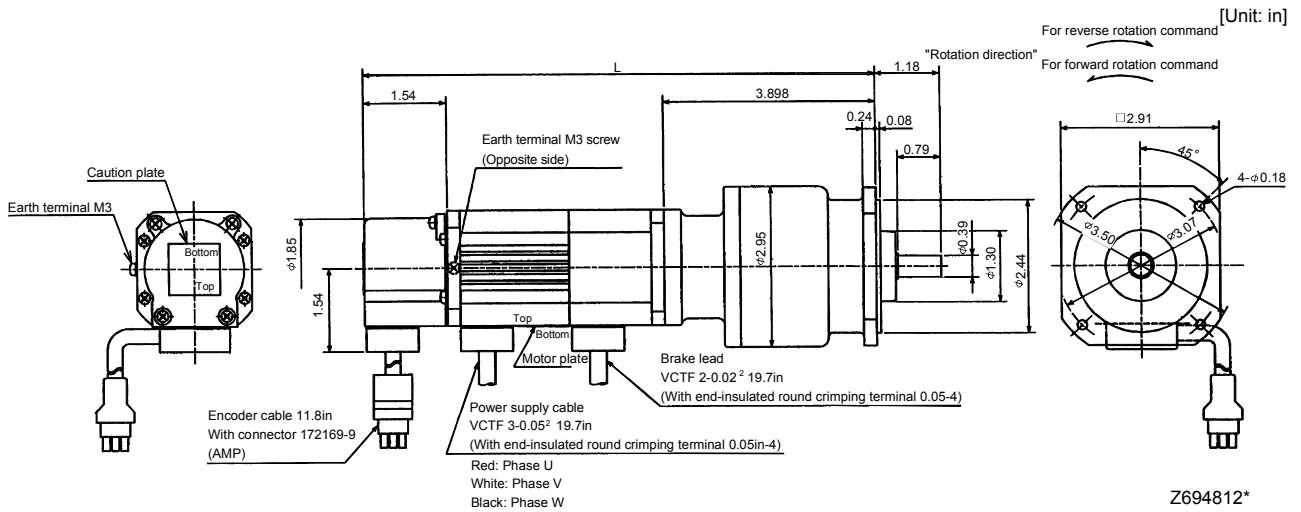

7. OUTLINE DIMENSION DRAWINGS

Model	Output [W]	Variable Dimensions [in]	Brake static friction torque [oz · in]	Reduction Gear Model	Reduction Ratio	Inertia Moment WK^2 [oz · in ²]	Backlash	Mass [lb]
		L						
HA-FF053BG2	50	9.764	55	BM3-25B-A5MES	1/25	0.66	3 min. max.	7.1
HA-FF13BG2	100	10.433	55	BM3-10B-01MES	1/10	1.00	3 min. max.	7.5
HA-FF13BG2	100	10.433	55	BM3-15B-01MES	1/15	0.95	3 min. max.	7.5

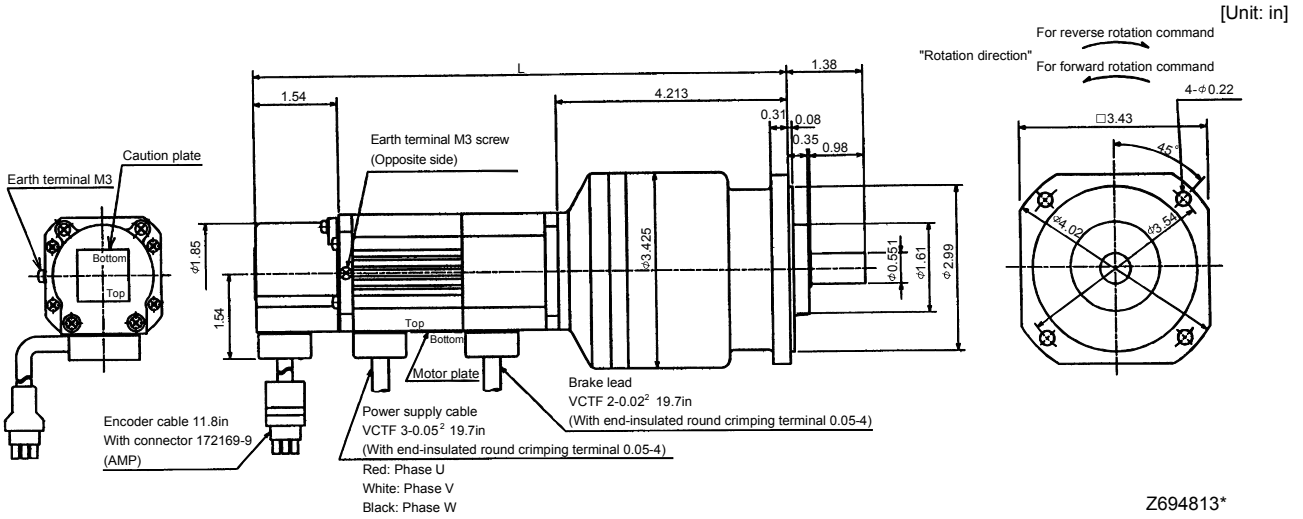

Model	Output [W]	Brake static friction torque [oz · in]	Reduction Gear Model	Reduction Ratio	Inertia Moment WK^2 [oz · in ²]	Backlash	Mass [lb]
HA-FF13BG2	100	55	BM4-25B-01MES	1/25	1.68	3 min. max.	11.7

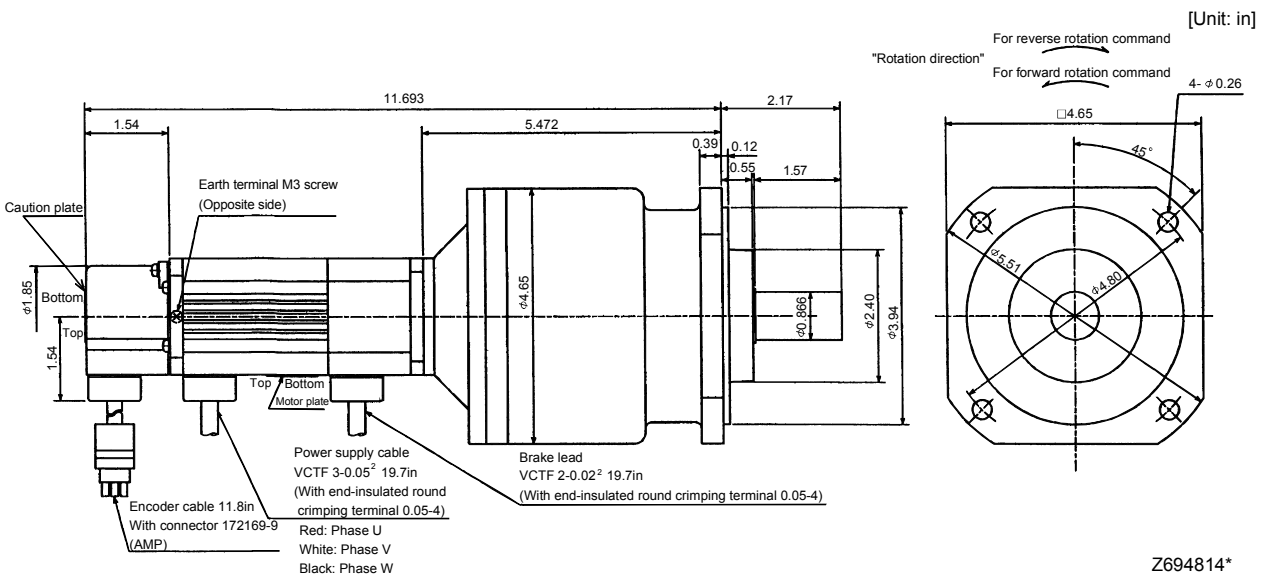

7. OUTLINE DIMENSION DRAWINGS

Model	Output [W]	Variable Dimensions [in]		Brake static friction torque [oz · in]	Reduction Gear Model	Reduction Ratio	Inertia Moment WK ² [oz · in ²]	Backlash	Mass [lb]
		L	H						
HA-FF23BG2	200	12.087		170	BM4-10B-02MES	1/10	4.25	3 min. max.	14.1
HA-FF23BG2	200	12.087		170	BM4-15B-02MES	1/15	4.10	3 min. max.	14.1
HA-FF33BG2	300	12.78		170	BM4-10B-03MES	1/10	5.07	3 min. max.	14.8

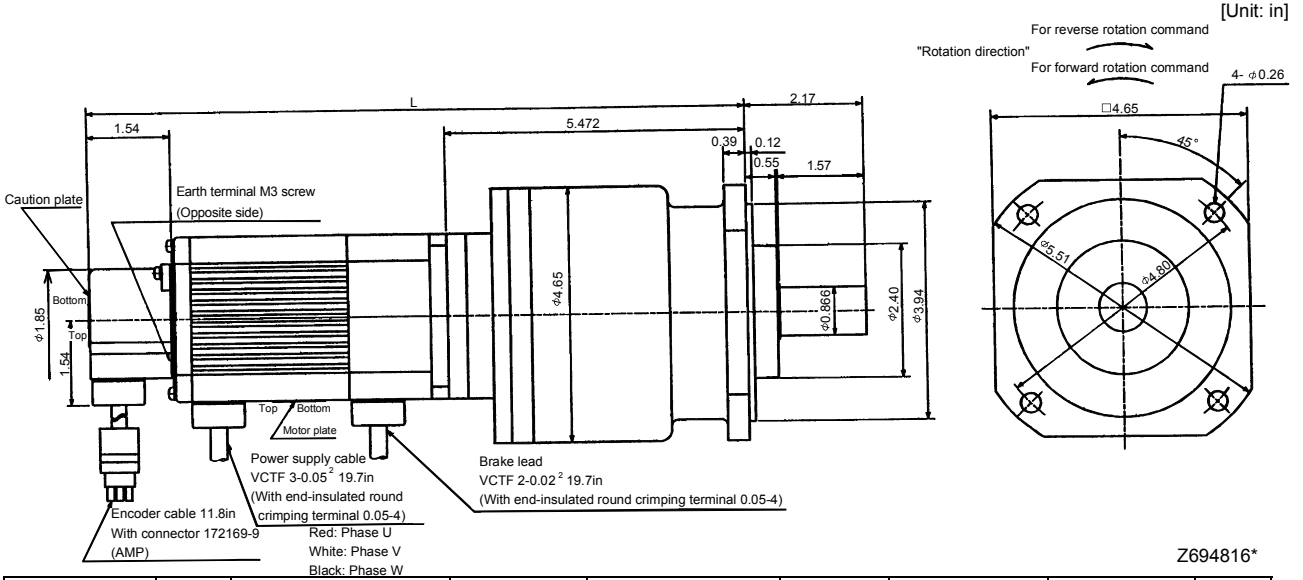

Model	Output [W]	Variable Dimensions [in]		Brake static friction torque [oz · in]	Reduction Gear Model	Reduction Ratio	Inertia Moment WK ² [oz · in ²]	Backlash	Mass [lb]
		L	H						
HA-FF23BG2	200	12.26	5.669	170	BL1-20B-02MES	1/20	4.84	3 min. max.	16.3
HA-FF23BG2	200	12.38	5.787	170	BL1-29B-02MES	1/29	4.18	3 min. max.	16.3
HA-FF33BG2	300	12.97	5.669	170	BL1-20B-03MES	1/20	5.54	3 min. max.	17.0

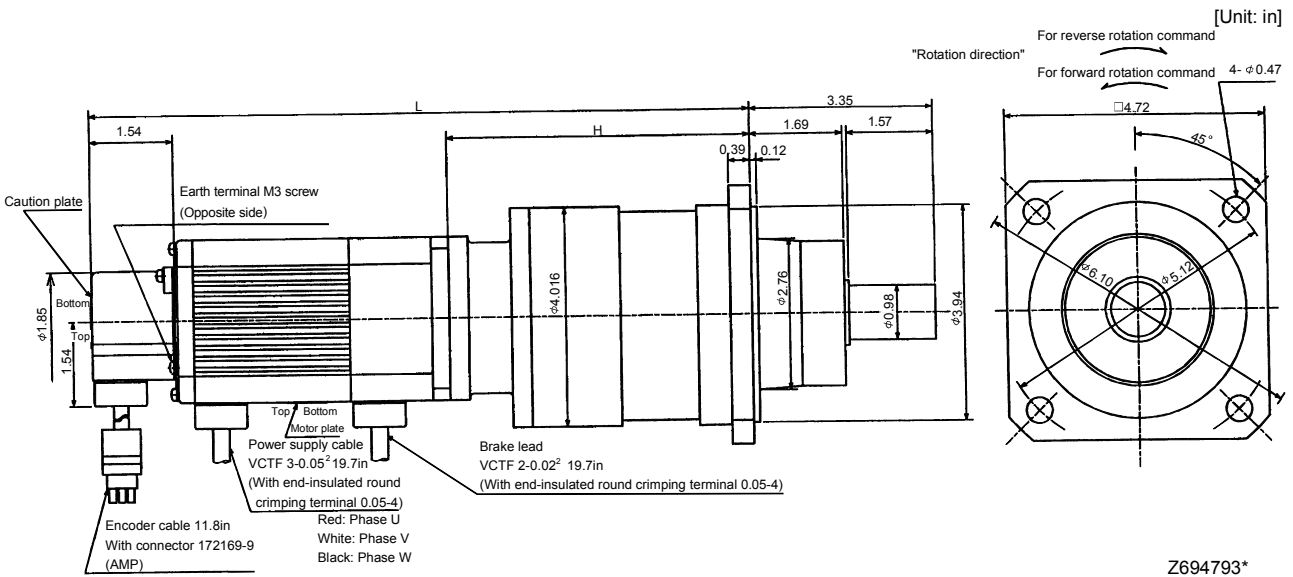

7. OUTLINE DIMENSION DRAWINGS

Model	Output [W]	Variable Dimensions [in]	Brake static friction torque [oz · in]	Reduction Gear Model	Reduction Ratio	Inertia Moment WK^2 [oz · in ²]	Backlash	Mass [lb]
		L						
HA-FF23BG2	200	13.23	170	BL2-45B-02MES	1/45	4.89	3 min. max.	28.4
HA-FF33BG2	300	13.92	170	BL2-29B-03MES	1/29	9.12	3 min. max.	29.1
HA-FF33BG2	300	14.31	170	BL2-45B-03MES	1/45	5.71	3 min. max.	29.1

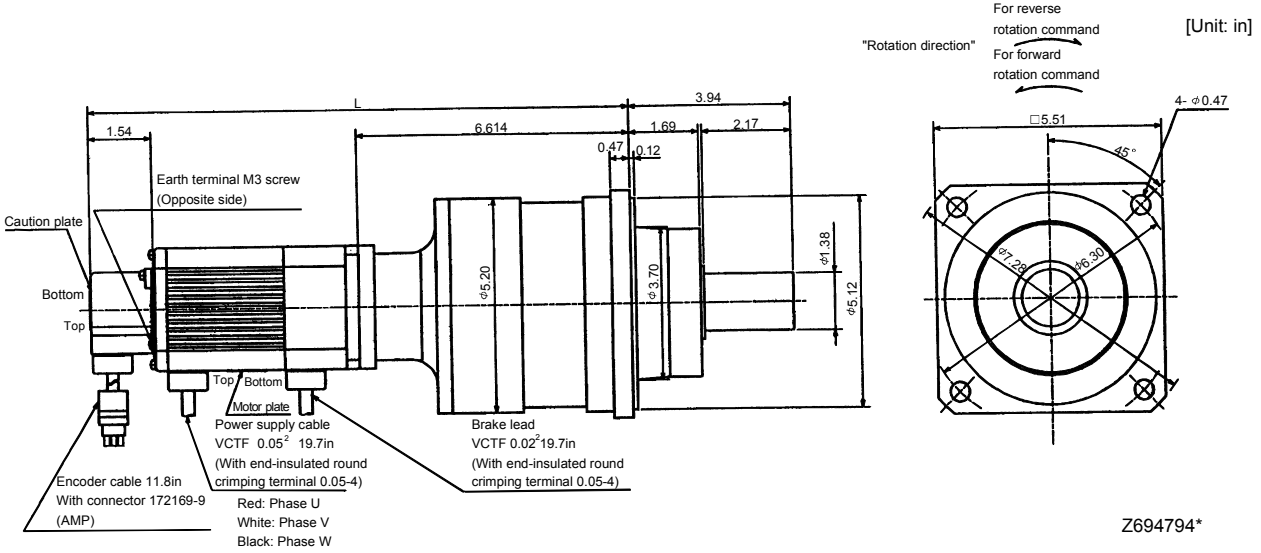

Model	Output [W]	Brake static friction torque [oz · in]	Reduction Gear Model	Reduction Ratio	Inertia Moment WK^2 [oz · in ²]	Backlash	Mass [lb]
HA-FF33BG2	300	170	BM4-05B-03MES	1/5	5.19	3 min. max.	14.8

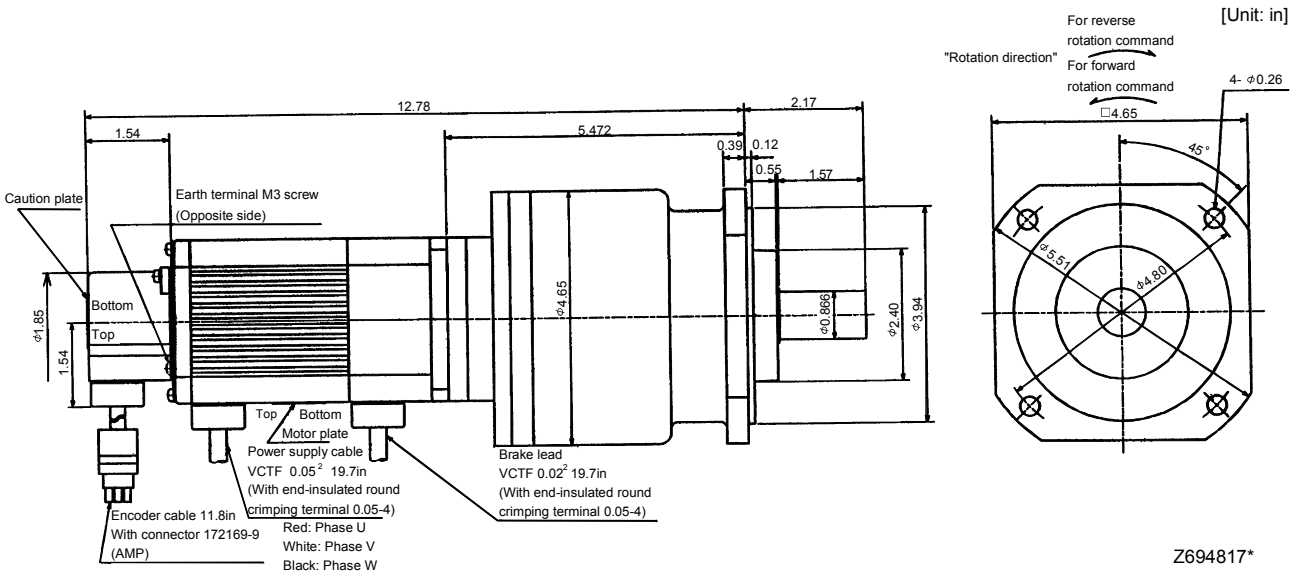

7. OUTLINE DIMENSION DRAWINGS

Model	Output [W]	Brake static friction torque [oz · in]	Reduction Gear Model	Reduction Ratio	Inertia Moment WK ² [oz · in ²]	Backlash	Mass [lb]
HA-FF43BG2	400	326	BM4-05B-04MES	1/5	8.98	3 min. max.	18.7

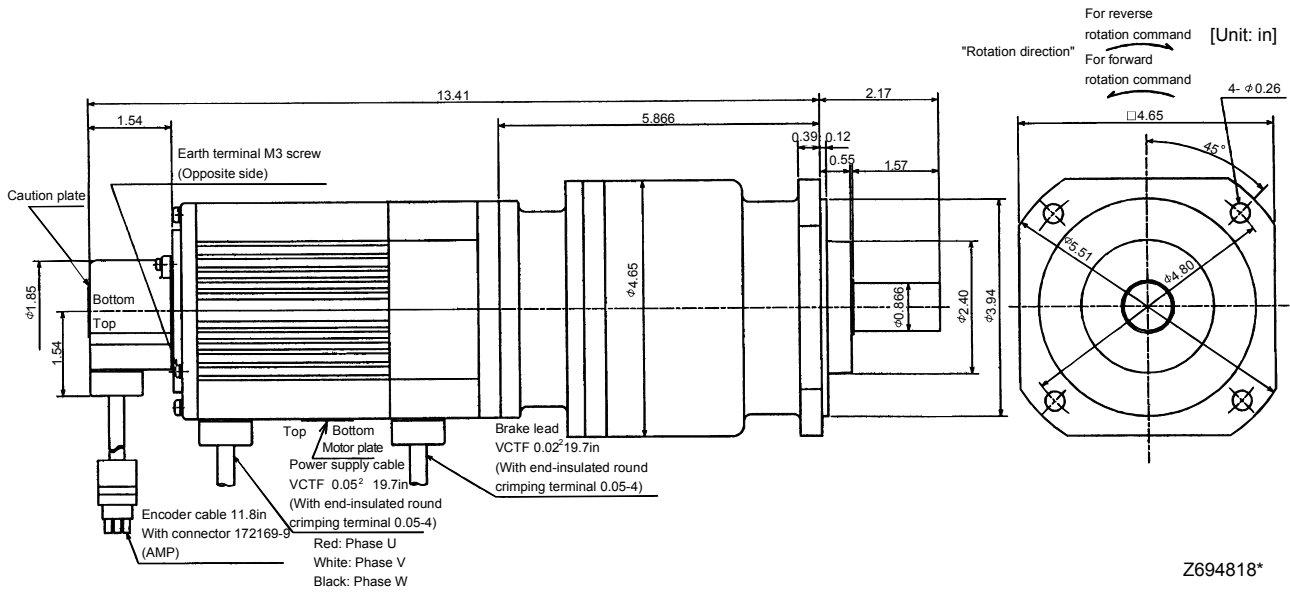

Model	Output [W]	Variable Dimensions [in]		Brake static friction torque [oz · in]	Reduction Gear Model	Reduction Ratio	Inertia Moment WK ² [oz · in ²]	Backlash	Mass [lb]
		L	H						
HA-FF43BG2	400	13.09	5.551	326	BL1-09B-04MES	1/9	8.43	3 min. max.	19.8
HA-FF63BG2	600	13.29	5.157	326	BL1-05B-06MES	1/5	10.16	3 min. max.	21.2
HA-FF63BG2	600	13.68	5.551	326	BL1-09B-06MES	1/9	9.66	3 min. max.	21.2

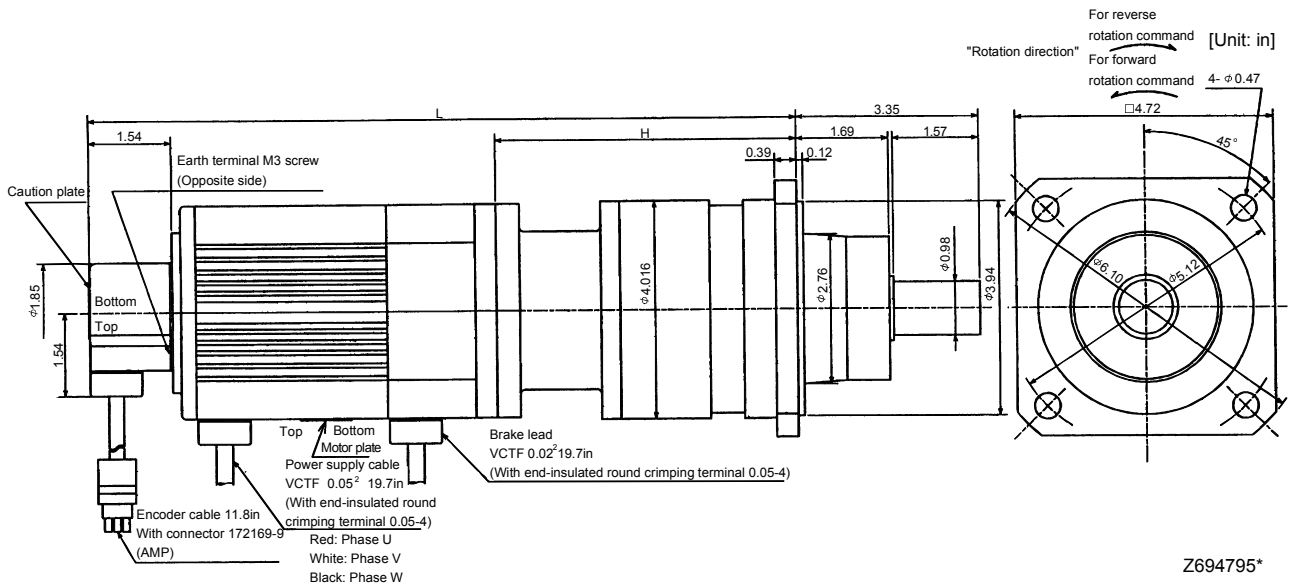

7. OUTLINE DIMENSION DRAWINGS

Model	Output [W]	Variable Dimensions [in]		Brake static friction torque [oz · in]	Reduction Gear Model	Reduction Ratio	Inertia Moment WK ² [oz · in ²]	Backlash	Mass [lb]
		L	H						
HA-FF43BG2	400	360.5	6.654	326	BL2-20B-04MES	1/20	14.91	3 min. max.	33.1
HA-FF43BG2	400	360.5	6.654	326	BL2-29B-04MES	1/29	12.90	3 min. max.	33.1
HA-FF43BG2	400	370.5	7.047	326	BL2-45B-04MES	1/45	9.50	3 min. max.	33.1
HA-FF63BG2	600	375.5	6.654	326	BL2-20B-06MES	1/20	16.14	3 min. max.	34.4
HA-FF63BG2	600	375.5	6.654	326	BL2-29B-06MES	1/29	14.13	3 min. max.	34.4

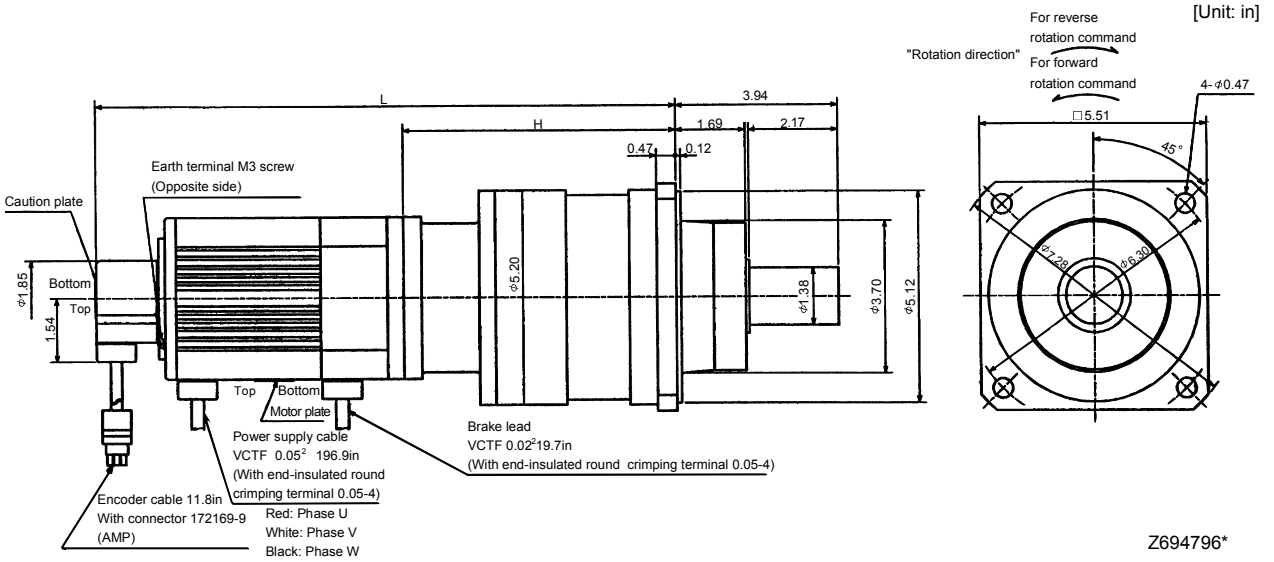

Model	Output [W]	Brake static friction torque [oz · in]	Reduction Gear Model	Reduction Ratio	Inertia Moment WK ² [oz · in ²]	Backlash	Mass [lb]
HA-FF63BG2	600	326	BM3-45B-06MES	1/45	19.00	3 min. max.	74.3

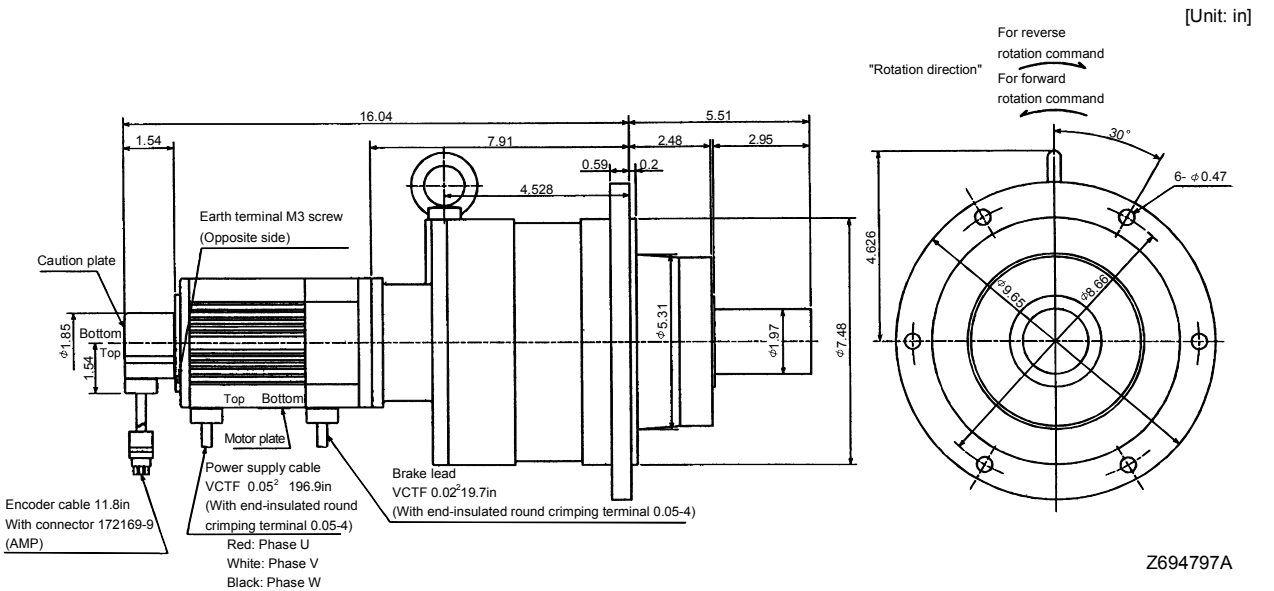

7. OUTLINE DIMENSION DRAWINGS

(5) EN · UL/C-UL Standard-Compliant model

(a) Standard (without electromagnetic brake, without reduction gear)

Model	Output [W]	Inertia Moment WK ² [oz · in ²]	Mass [lb]
HA-FF053C-UE	50	0.342	4.0

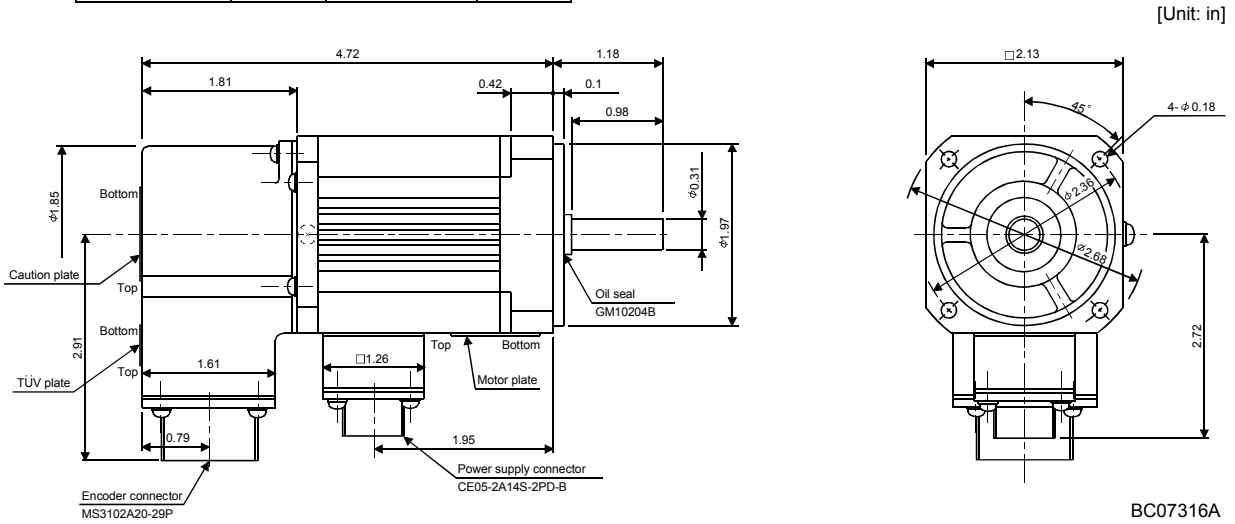

Model	Output [W]	Inertia Moment WK ² [oz · in ²]	Mass [lb]
HA-FF13C-UE	100	0.519	4.4

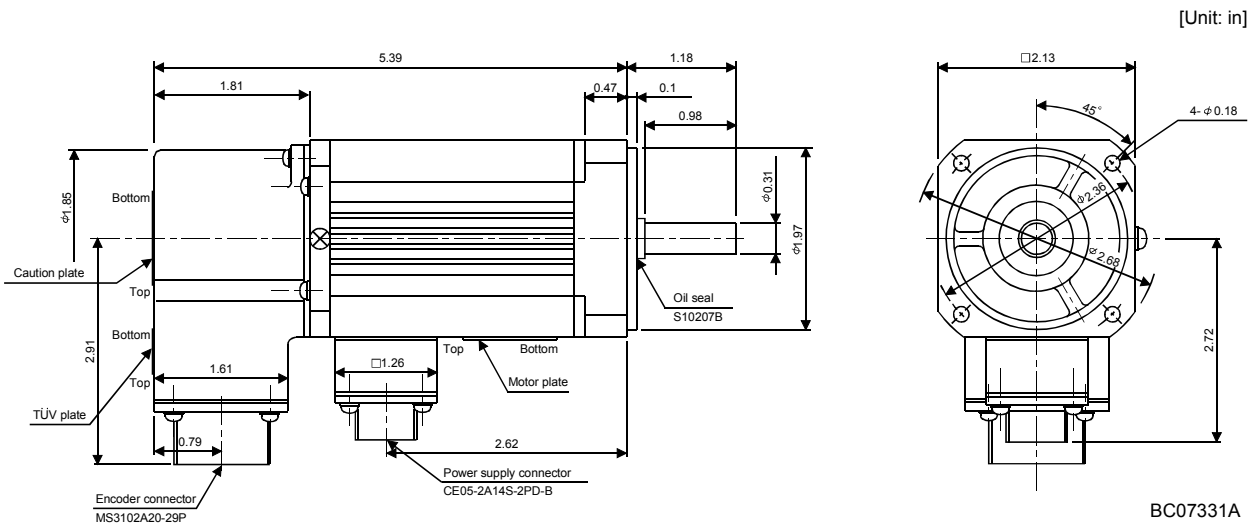

7. OUTLINE DIMENSION DRAWINGS

Model	Output [W]	Variable Dimensions [in]		Inertia Moment WK^2 [oz · in ²]	Mass [lb]
		L	KL		
HA-FF23C-UE	200	5.71	2.82	1.91	5.7
HA-FF33C-UE	300	6.38	3.50	2.73	6.4

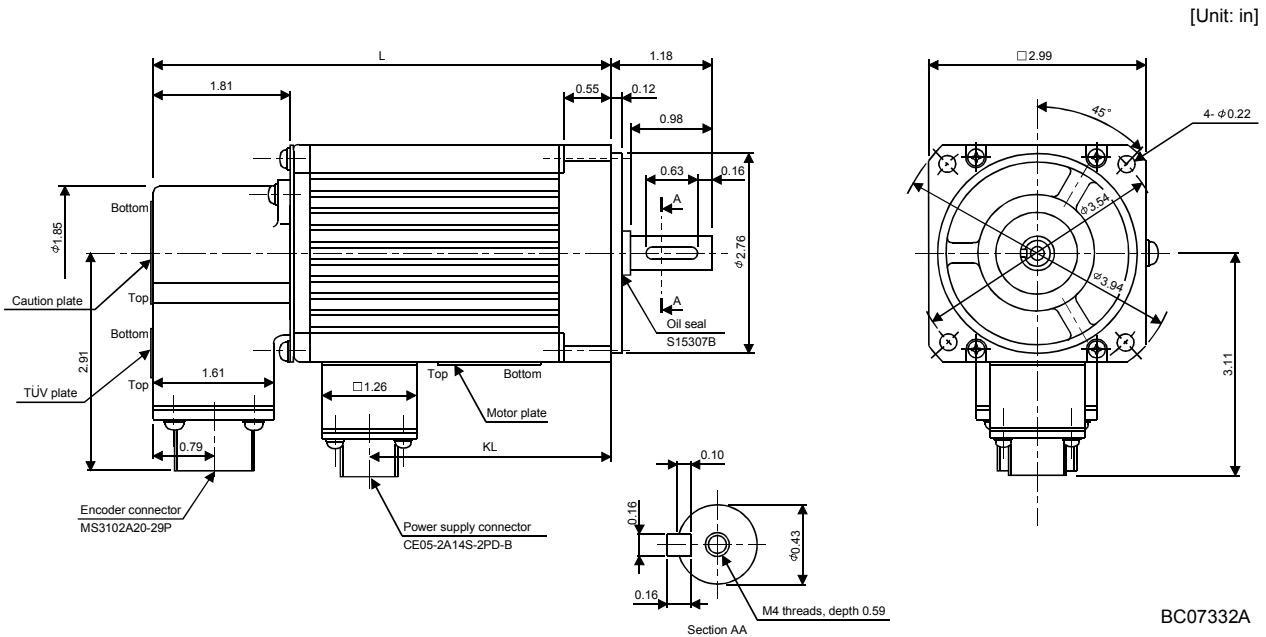

Model	Output [W]	Variable Dimensions [in]		Inertia Moment WK^2 [oz · in ²]	Mass [lb]
		L	KL		
HA-FF43C-UE	400	6.65	3.66	5.33	10.4
HA-FF63C-UE	600	7.24	4.25	6.56	11.7

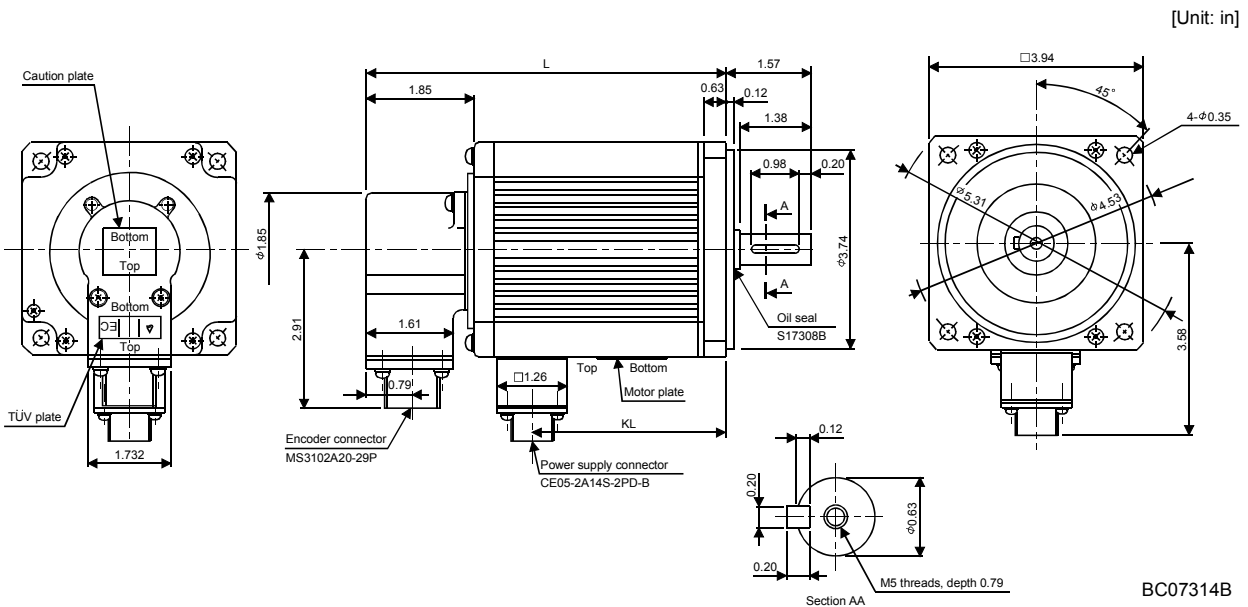

7. OUTLINE DIMENSION DRAWINGS

(b) With electromagnetic brake

Model	Output [W]	Inertia Moment WK^2 [oz · in ²]	Brake static friction torque [oz · in]	Mass [lb]
HA-FF053CB-UE	50	0.437	55	4.6

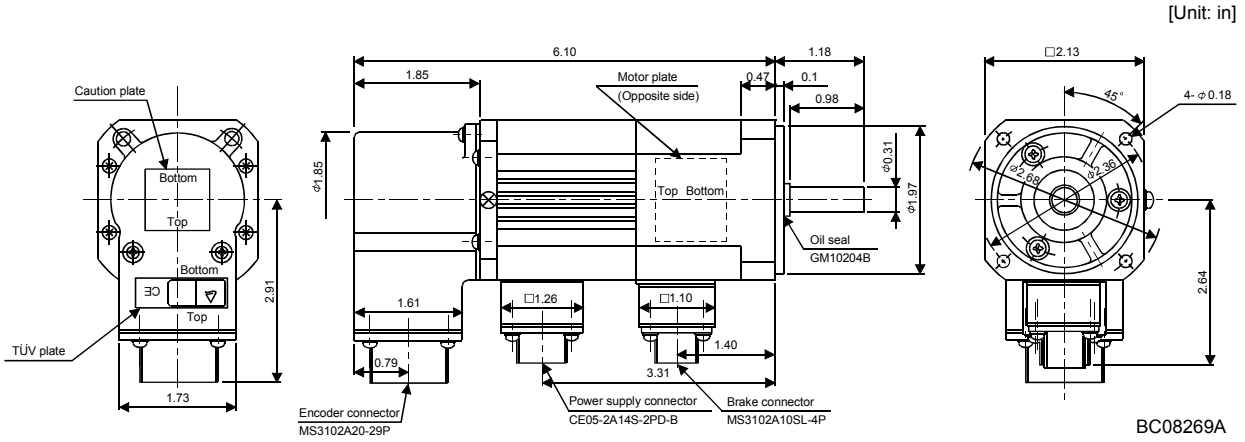

Model	Output [W]	Inertia Moment WK^2 [oz · in ²]	Brake static friction torque [oz · in]	Mass [lb]
HA-FF13CB-UE	100	0.615	55	5.1

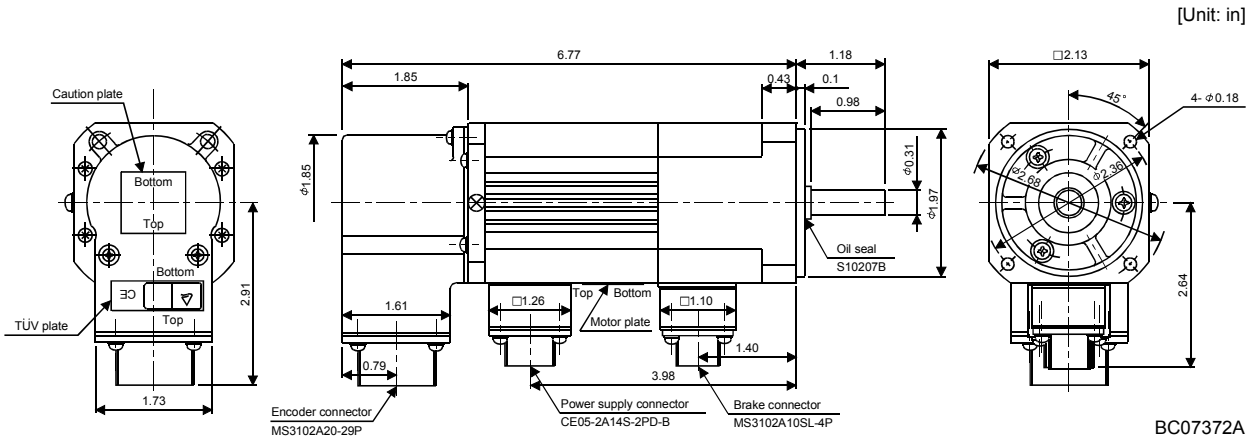

7. OUTLINE DIMENSION DRAWINGS

Model	Output [W]	Variable Dimensions [in]		Brake static friction torque [oz · in]	Inertia Moment WK^2 [oz · in ²]	Mass [lb]
		L	KL			
HA-FF23CB-UE	200	7.17	4.29	170	2.64	7.7
HA-FF33CB-UE	300	7.87	5.0		3.46	8.4

[Unit: in]

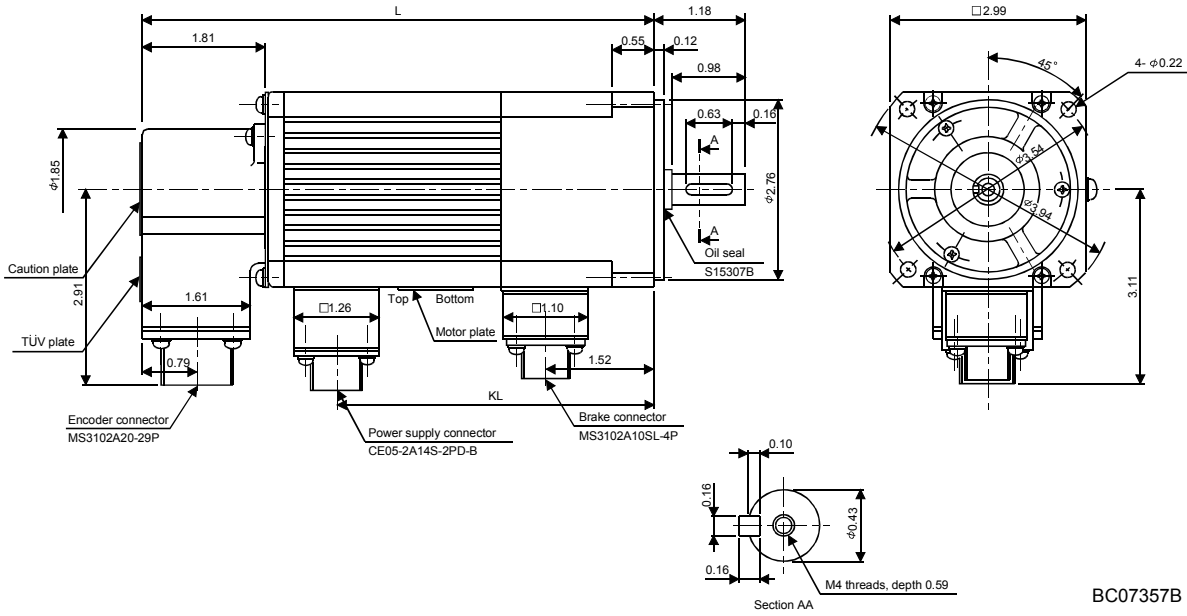

Model	Output [W]	Variable Dimensions [in]		Brake static friction torque [oz · in]	Inertia Moment WK^2 [oz · in ²]	Mass [lb]
		L	KL			
HA-FF43CB-UE	400	8.11	5.12	326	7.24	12.8
HA-FF63CB-UE	600	8.70	5.71		8.47	14.1

[Unit: in]

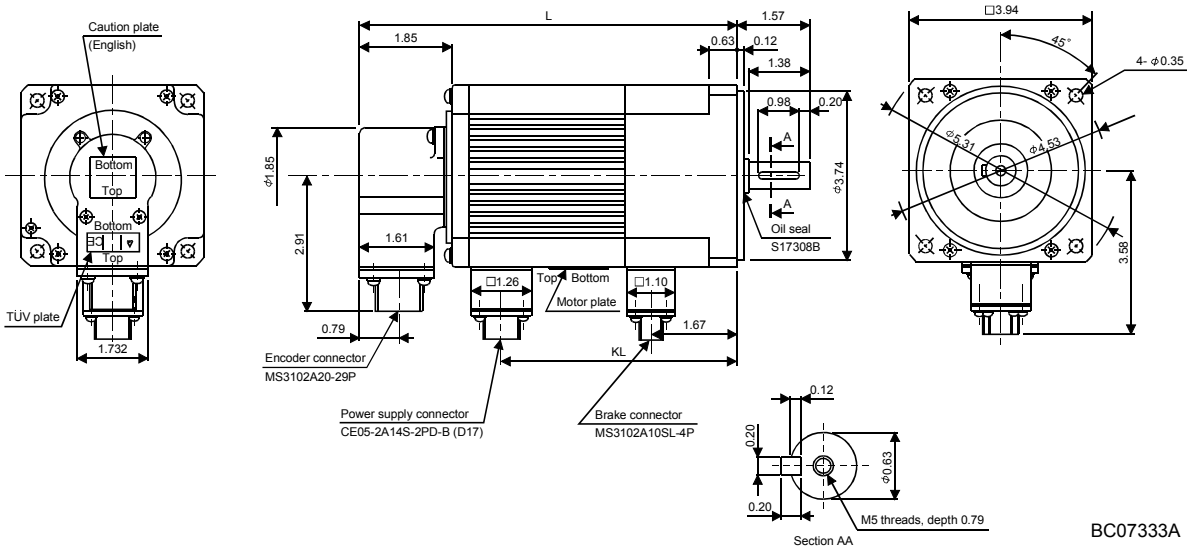

7. OUTLINE DIMENSION DRAWINGS

7.2.3 HC-SF • HC-SFS series

(1) Standard (without electromagnetic brake, without reduction gear)

Model			Output [kW]	Variable Dimensions [in]		Inertia Moment WK ² [oz • in ²]	Mass [lb]
				L	KL		
HC-SF52	HC-SFS52	HC-SFS524	0.5	4.72	2.03	36.22	11.0
HC-SF53	HC-SFS53						
HC-SF102	HC-SFS102	HC-SFS1024	1.0	5.71	3.02	74.90	15.4
HC-SF103	HC-SFS103						
HC-SF81	HC-SFS81	HC-SFS1524	0.85	6.69	4.00	109.08	19.8
HC-SF152	HC-SFS152		1.5				
HC-SF153	HC-SFS153						

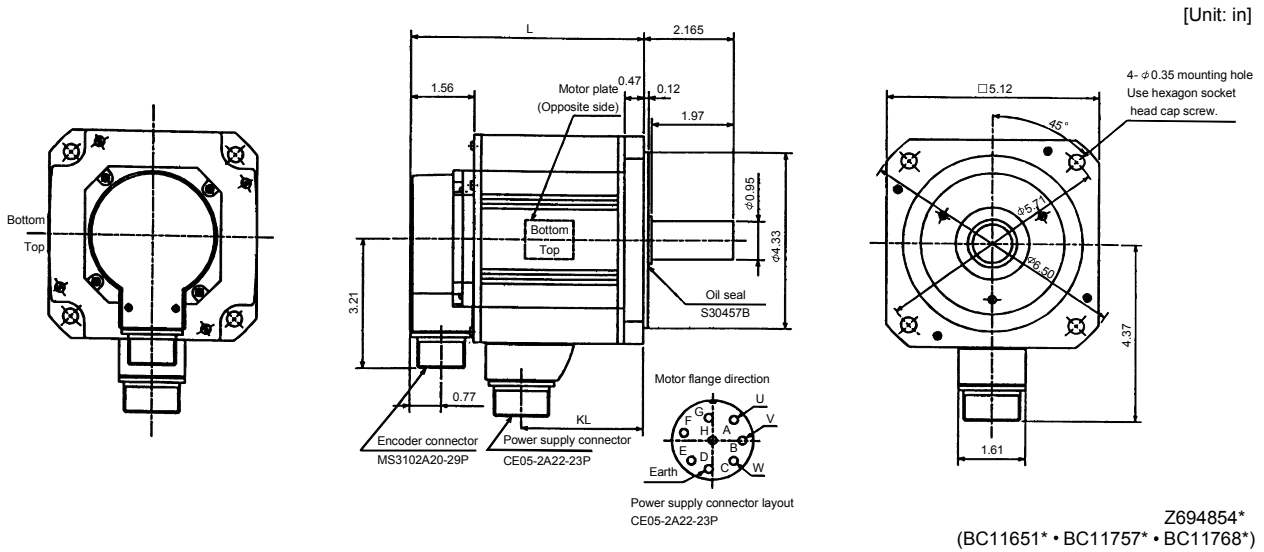

Model			Output [kW]	Variable Dimensions [in]		Inertia Moment WK ² [oz • in ²]	Mass [lb]
				L	KL		
HC-SF121	HC-SFS121	HC-SFS2024	1.2	5.71	2.70	232.37	26.5
HC-SF202	HC-SFS202		2.0				
HC-SF203	HC-SFS203		2.0				
HC-SF201	HC-SFS201	HC-SFS3524	2.0	7.36	4.35	448.33	41.9
HC-SF352	HC-SFS352		3.5				
HC-SF353	HC-SFS353						

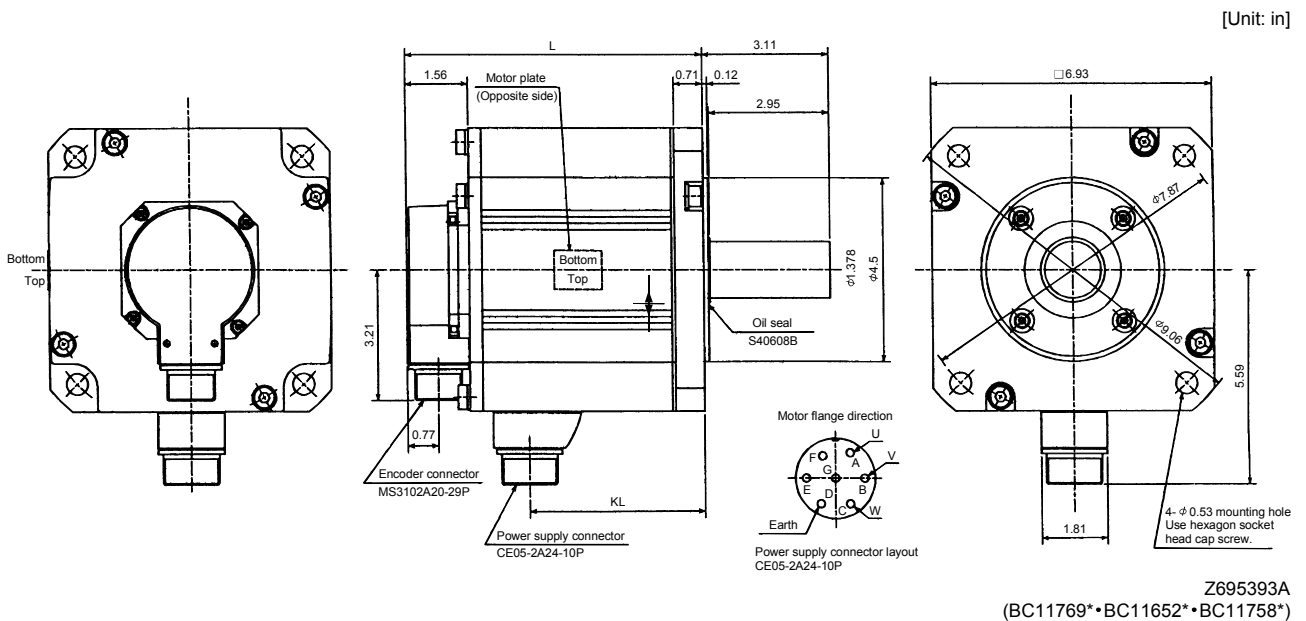

7. OUTLINE DIMENSION DRAWINGS

Model		Output [kW]	Inertia Moment WK^2 [oz · in ²]	Mass [lb]
HC-SF301	HC-SFS301	3.0	552.212	50.7

[Unit: in]

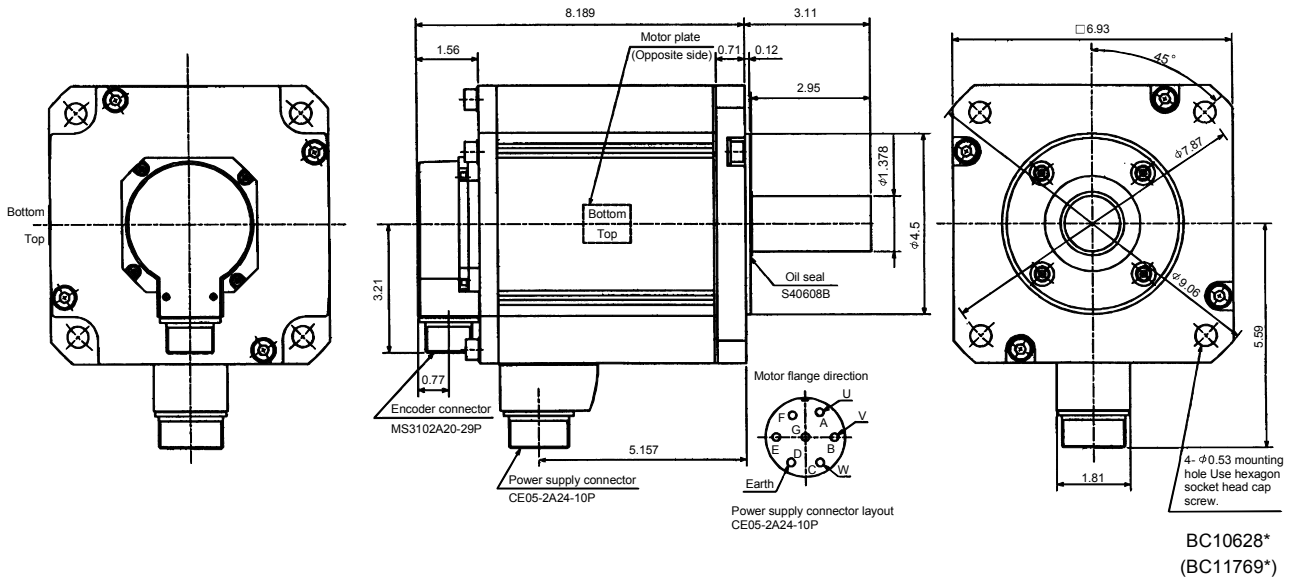

Model		Output [kW]	Inertia Moment WK^2 [oz · in ²]	Mass [lb]
HC-SF502	HC-SFS502 HC-SFS5024	5.0	552.212	50.7

[Unit: in]

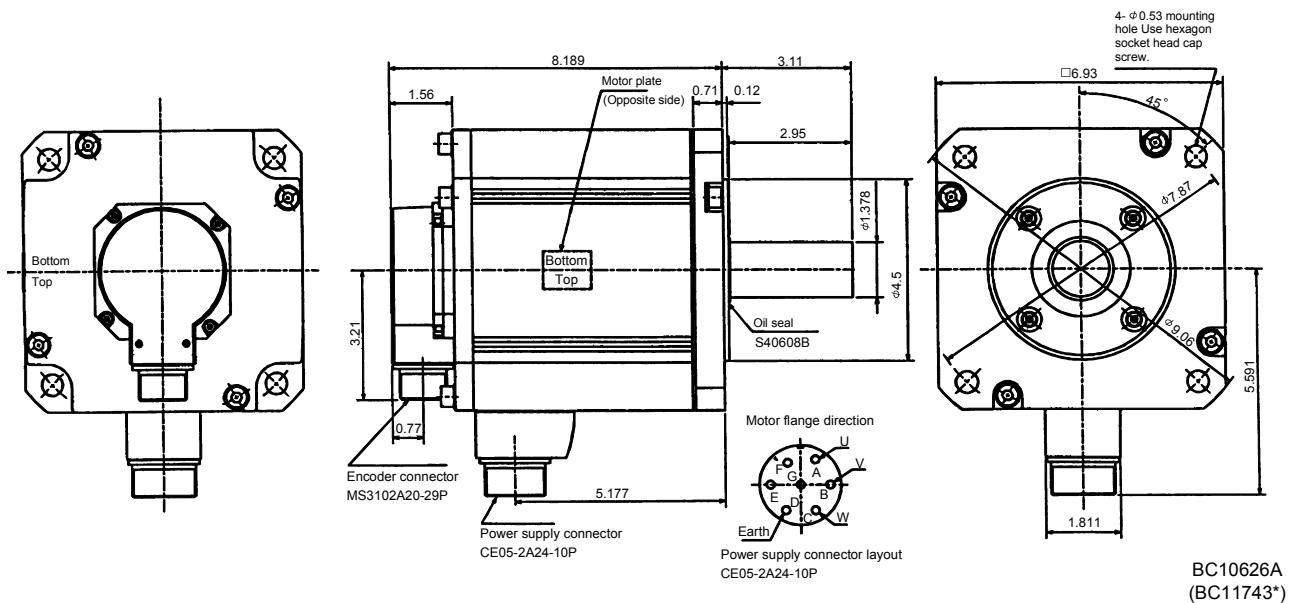

7. OUTLINE DIMENSION DRAWINGS

Model	Output [kW]	Inertia Moment WK ² [oz · in ²]	Mass [lb]
HC-SF702 HC-SFS702 HC-SFS7024	7.0	874.791	70.5

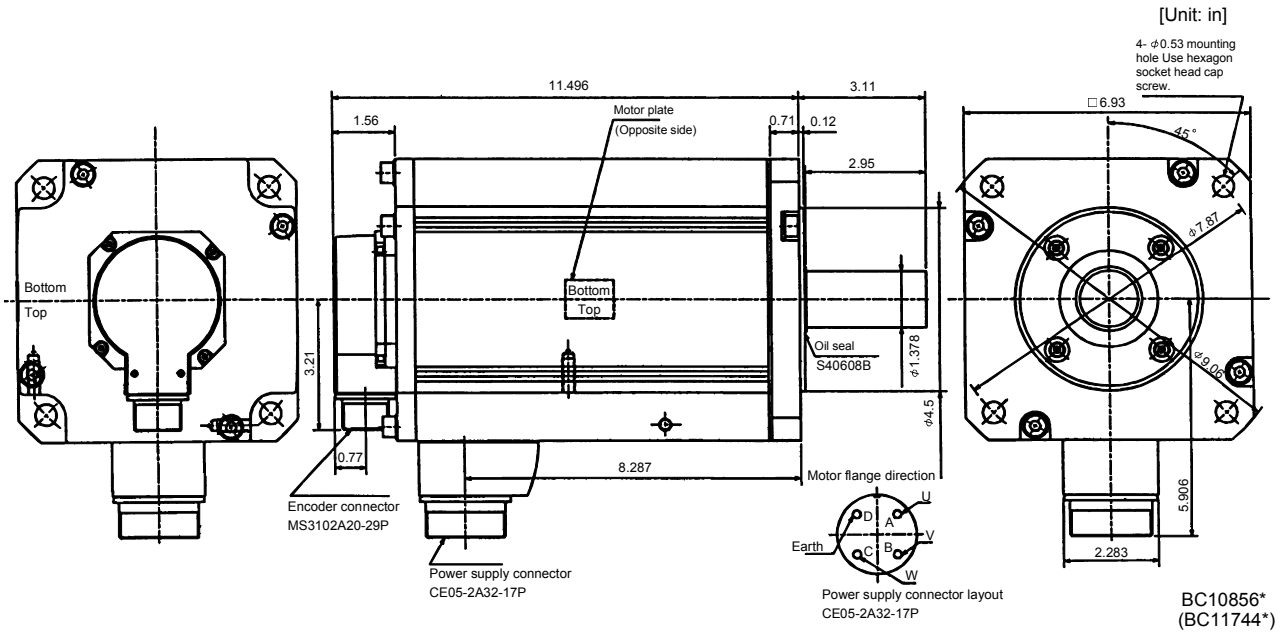

(2) With electromagnetic brake

Model	Output [kW]	Variable Dimensions [in]		Brake static friction torque [oz · in]	Inertia Moment WK ² [oz · in ²]	Mass [lb]
		L	KL			
HC-SF52B HC-SF53B HC-SFS524B	0.5	6.02	2.03	1204	45.52	16.535
HC-SF102B HC-SF103B HC-SFS1024B	1.0	7.01	3.02	1204	84.20	20.944
HC-SF81B HC-SF152B HC-SF153B	0.85 1.5	7.99	4.00	1204	118.37	25.353

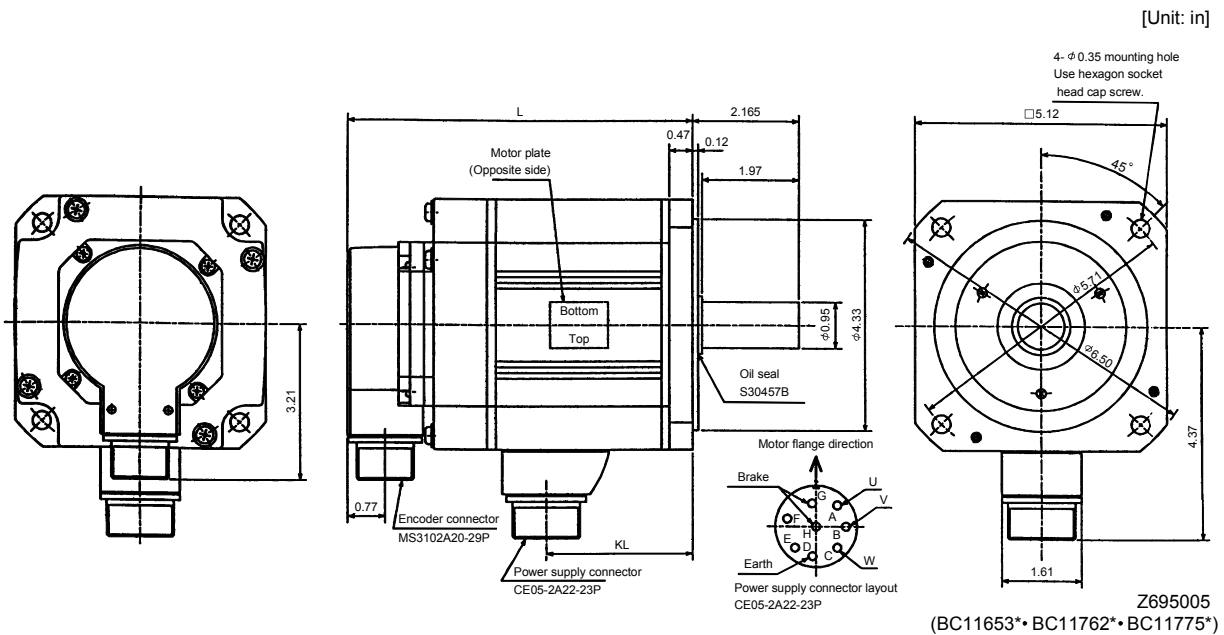

7. OUTLINE DIMENSION DRAWINGS

Model	Output [kW]	Variable Dimensions [in]		Brake static friction torque [oz · in]	Inertia Moment WK^2 [oz · in ²]	Mass [lb]
		L	KL			
HC-SF121B HC-SFS 121B	1.2					
HC-SF202B HC-SFS 202B HC-SF203B HC-SFS 203B HC-SFS 2024B	2.0	7.60	2.70	6103	287.04	39.683
HC-SF201B HC-SFS 201B	2.0					
HC-SF352B HC-SFS 352B HC-SF353B HC-SFS 353B HC-SFS3524B	3.5	9.25	4.35	6103	503.01	55.115

[Unit: in]

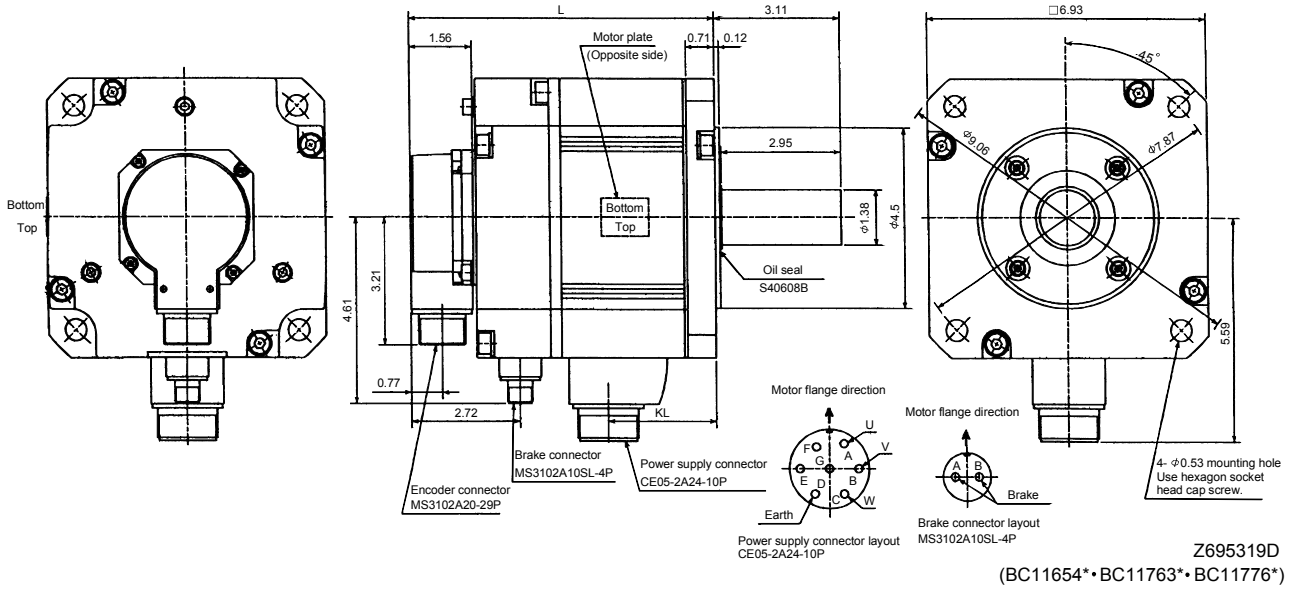

Model	Output [kW]	Brake static friction torque [oz · in]	Inertia Moment WK^2 [oz · in ²]	Mass [lb]
HC-SF301B HC-SFS301B	3.0	6103	606.886	63.9

[Unit: in]

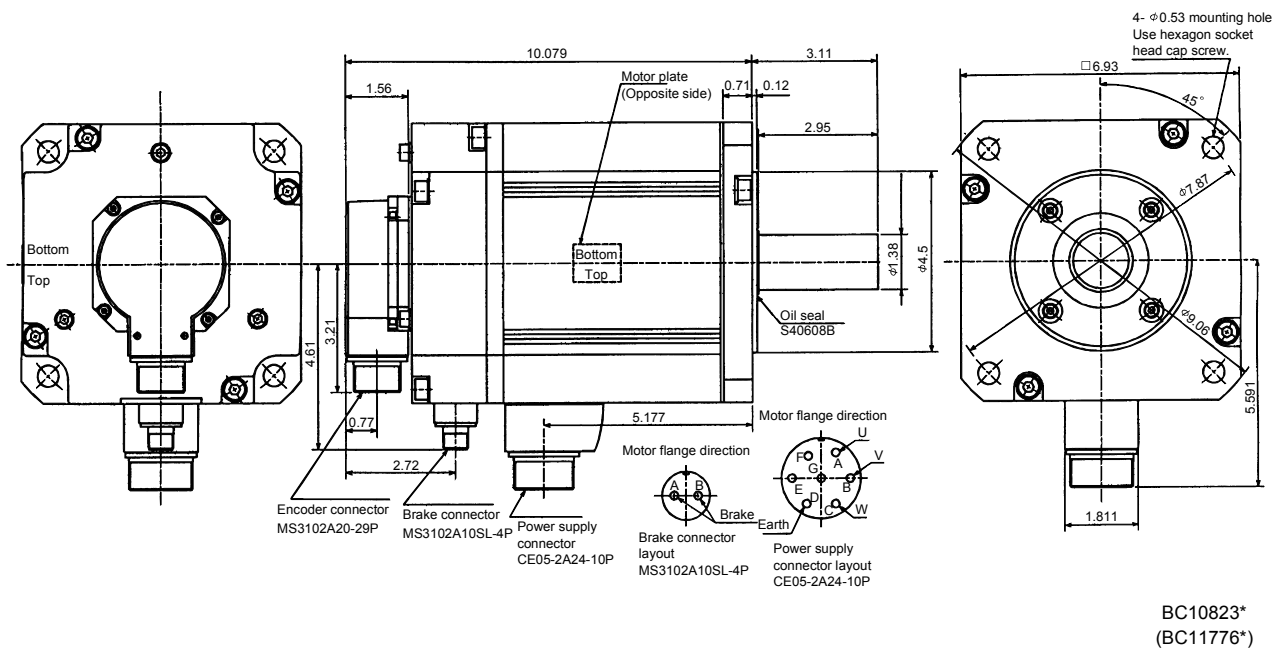

7. OUTLINE DIMENSION DRAWINGS

Model	Output [kW]	Brake static friction torque [oz · in]	Inertia Moment WK^2 [oz · in ²]	Mass [lb]
HC-SF502B HC-SFS502B HC-SFS5024B	5.0	6103	606.886	63.9

[Unit: in]

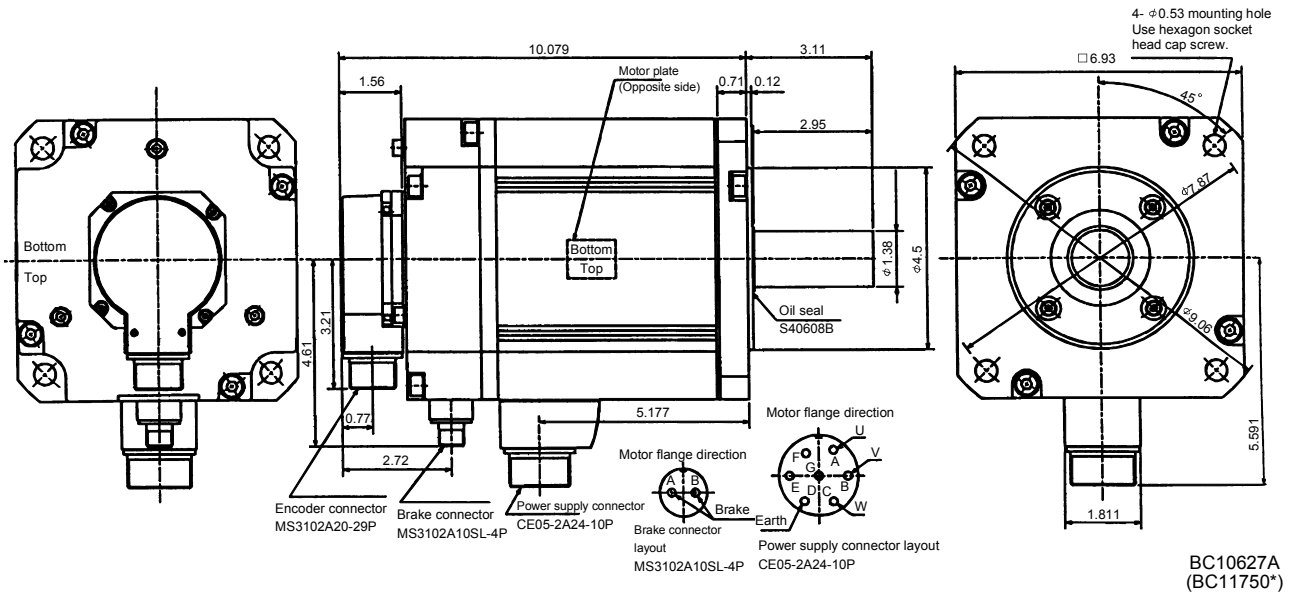

Model	Output [kW]	Brake static friction torque [oz · in]	Inertia Moment WK^2 [oz · in ²]	Mass [lb]
HC-SF702B HC-SFS702B HC-SFS7024B	7.0	6103	929.466	83.8

[Unit: in]

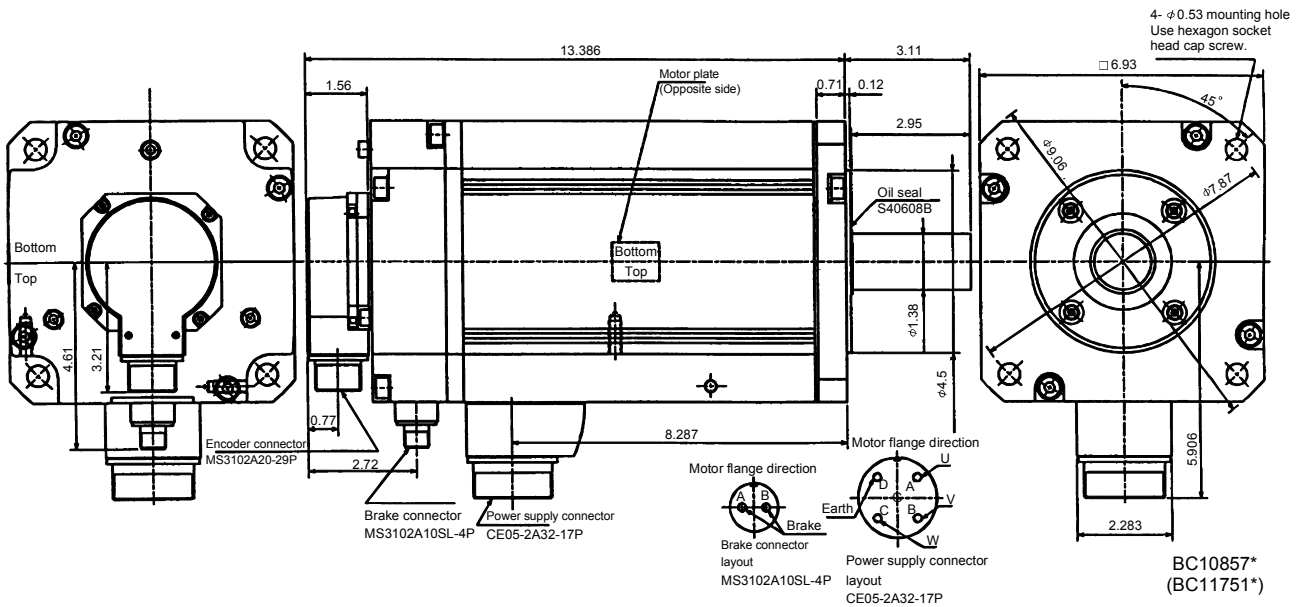

7. OUTLINE DIMENSION DRAWINGS

(3) With reduction gear for general industrial machine (leg type)

The outer frame of the reduction gear is a material surface such as casting. Its actual dimensions may be 0.039 to 0.118 in larger than the drawing dimensions. Design the machine side with allowances.

(a) Without electromagnetic brake

Model			Output [kW]	Reduction Ratio	Inertia Moment WK ² [oz · in ²]	Variable Dimensions [in]	Mass [lb]
						L	
HC-SF52G1H	HC-SFS52G1H	HC-SFS524G1H	0.5	1/35	41.01	13.31	61.7
HC-SF52G1H	HC-SFS52G1H	HC-SFS524G1H	0.5	1/43	40.73	13.31	61.7
HC-SF52G1H	HC-SFS52G1H	HC-SFS524G1H	0.5	1/59	40.60	13.31	61.7
HC-SF102G1H	HC-SFS102G1H	HC-SFS1024G1H	1.0	1/6	91.85	14.30	66.1
HC-SF102G1H	HC-SFS102G1H	HC-SFS1024G1H	1.0	1/11	83.7	14.30	66.1
HC-SF102G1H	HC-SFS102G1H	HC-SFS1024G1H	1.0	1/17	81.47	14.30	66.1
HC-SF102G1H	HC-SFS102G1H	HC-SFS1024G1H	1.0	1/29	79.83	14.30	66.1
HC-SF102G1H	HC-SFS102G1H	HC-SFS1024G1H	1.0	1/35	79.8	14.30	66.1
HC-SF152G1H	HC-SFS152G1H	HC-SFS1524G1H	1.5	1/6	126.3	15.28	70.5
HC-SF152G1H	HC-SFS152G1H	HC-SFS1524G1H	1.5	1/11	117.55	15.28	70.5
HC-SF152G1H	HC-SFS152G1H	HC-SFS1524G1H	1.5	1/17	115.9	15.28	70.5

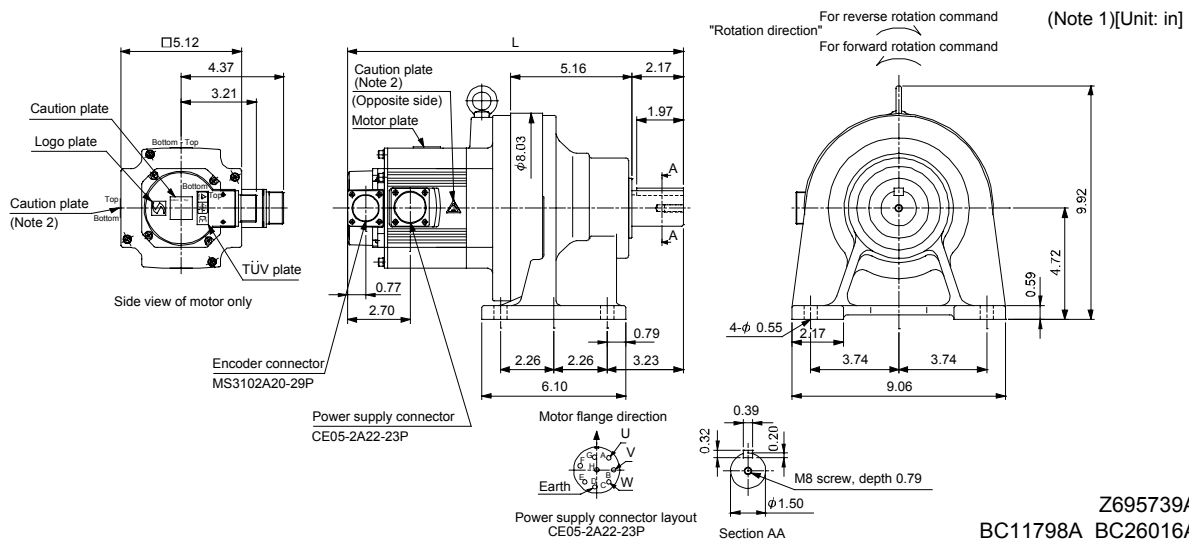

Note 1. The dimensions without tolerances are reference dimensions.
2. This caution plate is attached to the 400V class motors only, not to the 200V class.

Model			Output [kW]	Reduction Ratio	Inertia Moment WK ² [oz · in ²]	Mass [lb]
HC-SF52G1H	HC-SFS52G1H	HC-SFS524G1H				
HC-SF52G1H	HC-SFS52G1H	HC-SFS524G1H	0.5	1/11	38.00	46.3
HC-SF52G1H	HC-SFS52G1H	HC-SFS524G1H	0.5	1/17	37.45	46.3
HC-SF52G1H	HC-SFS52G1H	HC-SFS524G1H	0.5	1/29	37.04	46.3

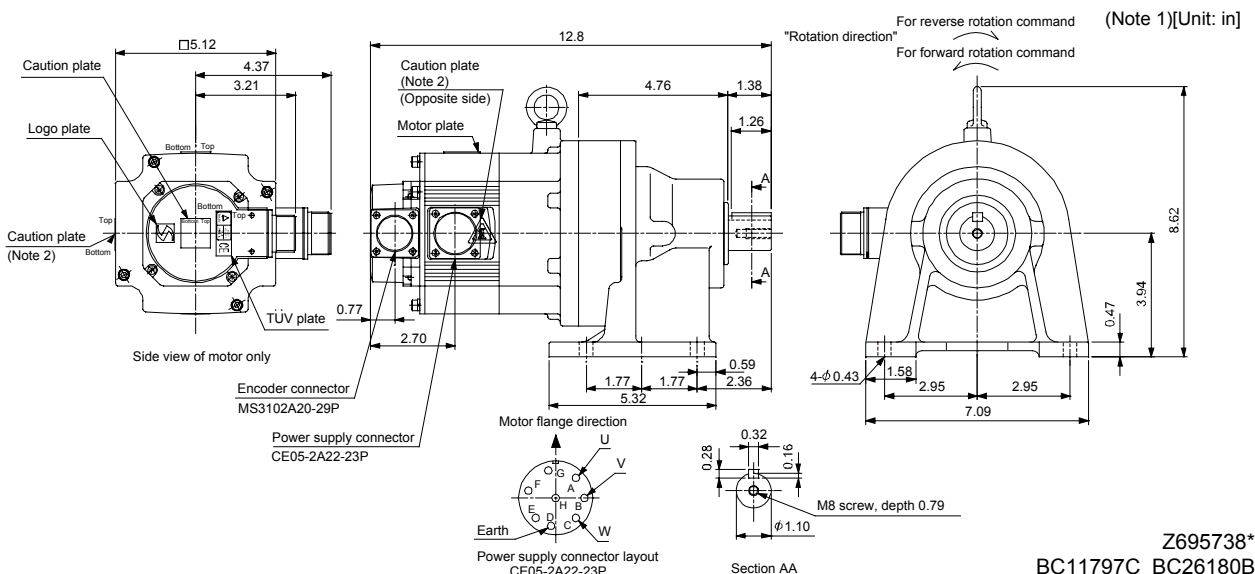

Note 1. The dimensions without tolerances are reference dimensions.
2. This caution plate is attached to the 400V class motors only, not to the 200V class.

7. OUTLINE DIMENSION DRAWINGS

Model			Output [kW]	Reduction Ratio	Inertia Moment WK ² [oz · in ²]	Variable Dimensions [in]	Mass [lb]
						L	
HC-SF102G1H	HC-SFS102G1H	HC-SFS1024G1H	1.0	1/59	106.51	19.21	198.4
HC-SF152G1H	HC-SFS152G1H	HC-SFS1524G1H	1.5	1/43	141.06	20.20	202.8
HC-SF152G1H	HC-SFS152G1H	HC-SFS1524G1H	1.5	1/59	140.68	20.20	202.8

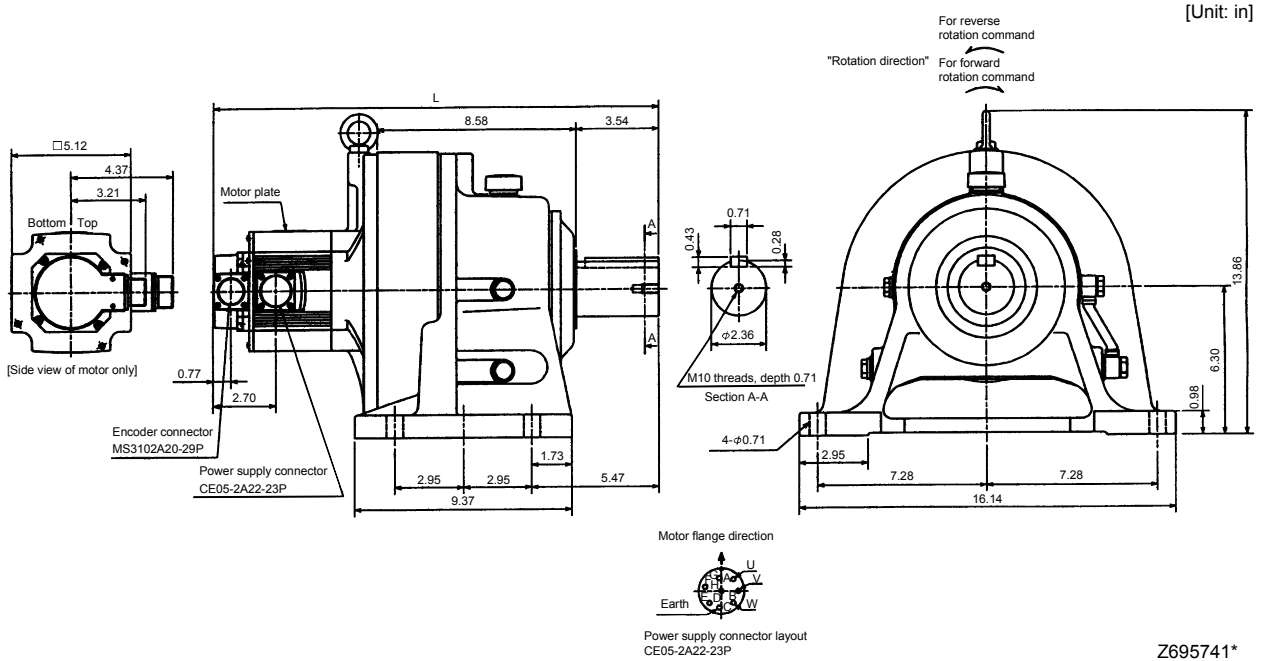

Model			Output [kW]	Reduction Ratio	Inertia Moment WK ² [oz · in ²]	Variable Dimensions [in]	Mass [lb]
						L	
HC-SF102G1H	HC-SFS102G1H	HC-SFS1024G1H	1.0	1/43	85.57	16.38	112.4
HC-SF152G1H	HC-SFS152G1H	HC-SFS1524G1H	1.5	1/29	120.72	17.36	116.8
HC-SF152G1H	HC-SFS152G1H	HC-SFS1524G1H	1.5	1/35	120.45	17.36	116.8

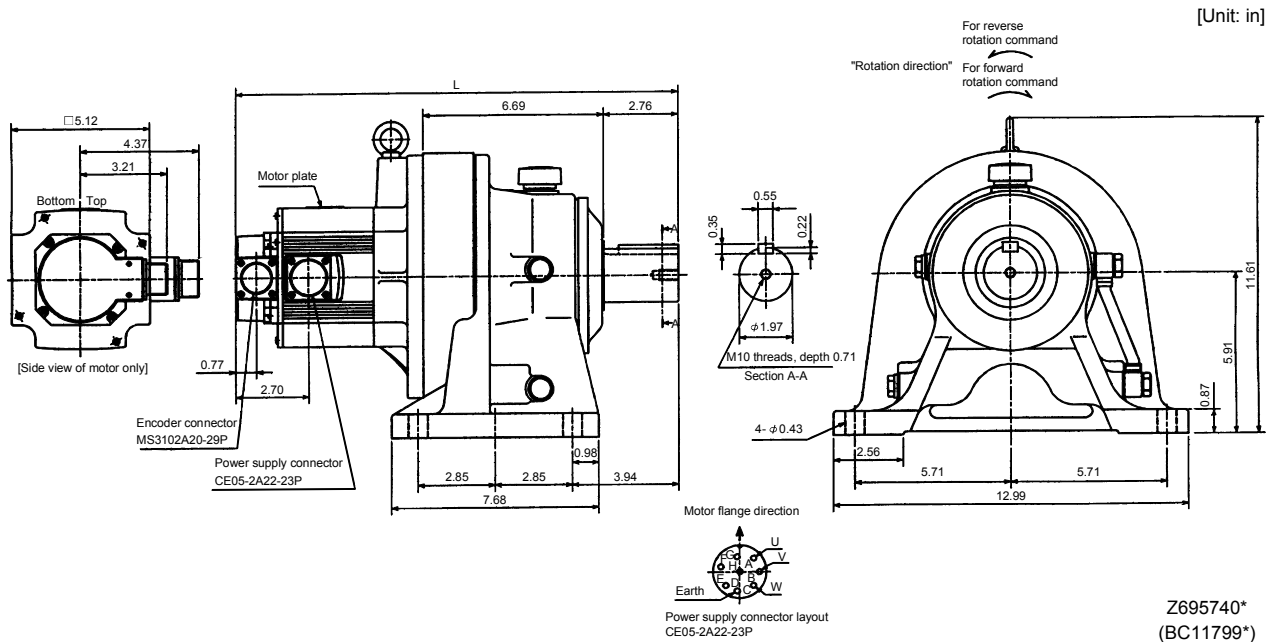

7. OUTLINE DIMENSION DRAWINGS

Model	Output [kW]	Reduction Ratio	Inertia Moment WK ² [oz · in ²]	Mass [lb]
HC-SF202G1H HC-SFS202G1H HC-SFS2024G1H	2.0	1/6	249.32	77.2
HC-SF202G1H HC-SFS202G1H HC-SFS2024G1H	2.0	1/11	241.11	77.2
HC-SF202G1H HC-SFS202G1H HC-SFS2024G1H	2.0	1/17	238.93	77.2

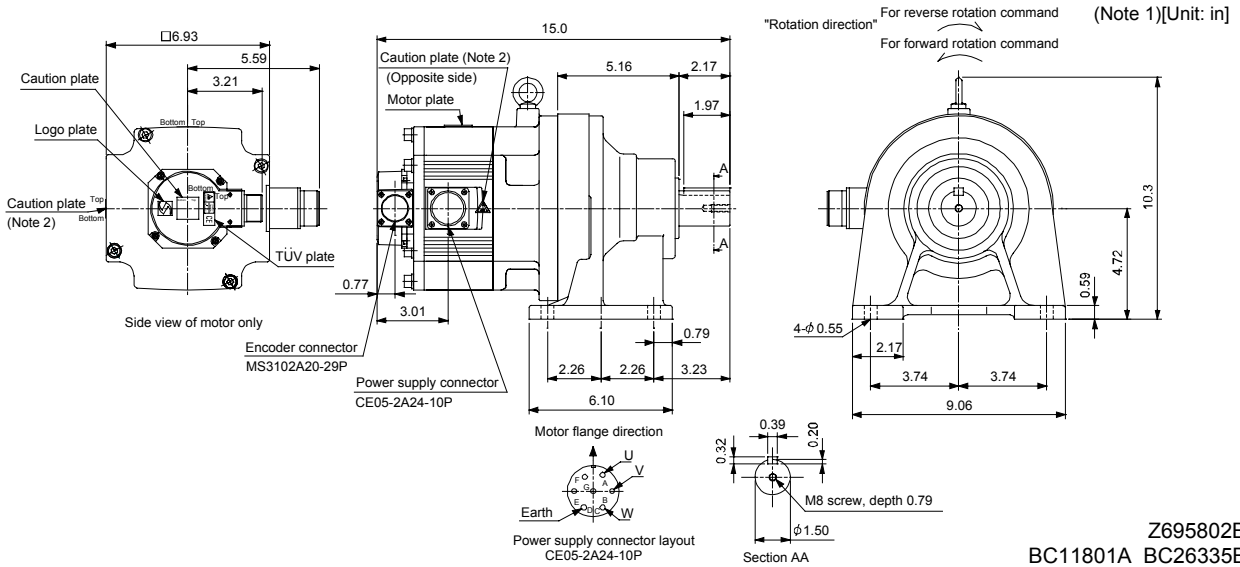

Note 1. The dimensions without tolerances are reference dimensions.
 2. This caution plate is attached to the 400V class motors only, not to the 200V class.

Model	Output [kW]	Reduction Ratio	Inertia Moment WK ² [oz · in ²]	Mass [lb]
HC-SF352G1H HC-SFS352G1H HC-SFS3524G1H	3.5	1/6	492.62	132.3
HC-SF352G1H HC-SFS352G1H HC-SFS3524G1H	3.5	1/11	471.21	132.3
HC-SF352G1H HC-SFS352G1H HC-SFS3524G1H	3.5	1/17	464.73	132.3

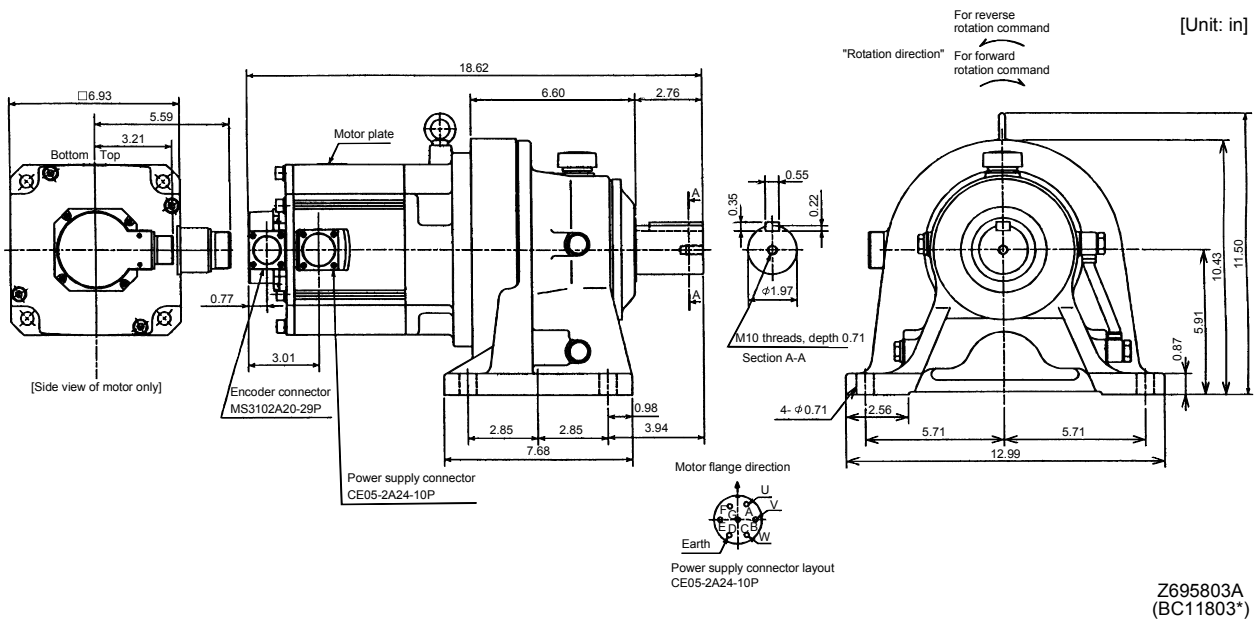

7. OUTLINE DIMENSION DRAWINGS

Model		Output [kW]	Reduction Ratio	Inertia Moment WK ² [oz · in ²]	Variable Dimensions [in]	Mass [lb]
					L	
HC-SF202G1H	HC-SFS202G1H HC-SFS2024G1H	2.0	1/29	267.36	19.61	200.6
HC-SF202G1H	HC-SFS202G1H HC-SFS2024G1H	2.0	1/35	265.72	19.61	200.6
HC-SF202G1H	HC-SFS202G1H HC-SFS2024G1H	2.0	1/43	264.62	19.61	200.6
HC-SF202G1H	HC-SFS202G1H HC-SFS2024G1H	2.0	1/59	464.08	19.61	200.6
HC-SF352G1H	HC-SFS352G1H HC-SFS3524G1H	3.5	1/29	483.32	21.26	216.1
HC-SF352G1H	HC-SFS352G1H HC-SFS3524G1H	3.5	1/35	481.68	21.26	216.1

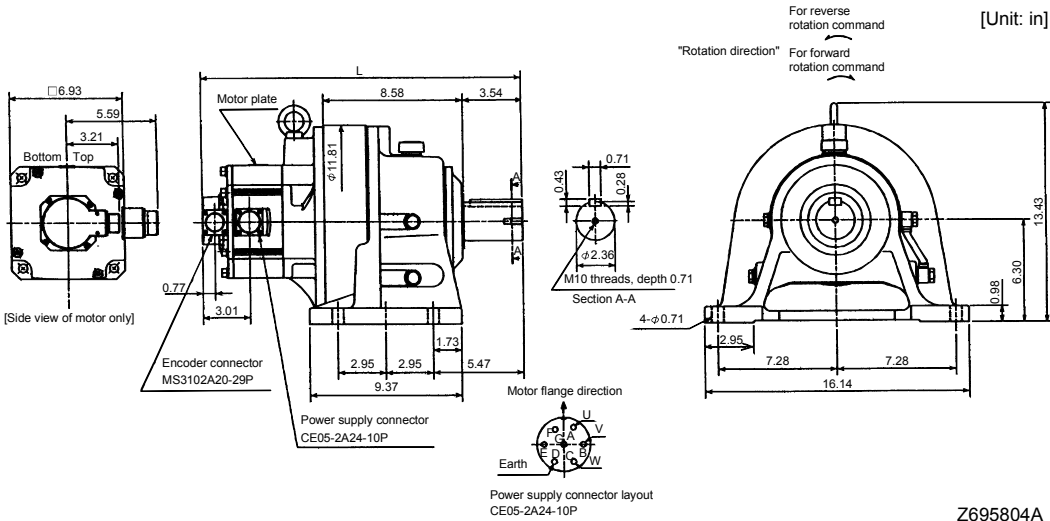

Model		Output [kW]	Reduction Ratio	Inertia Moment WK ² [oz · in ²]	Mass [lb]
HC-SF352G1H	HC-SFS352G1H HC-SFS3524G1H	3.5	1/43	582.28	306.4
HC-SF352G1H	HC-SFS352G1H HC-SFS3524G1H	3.5	1/59	579.0	306.4

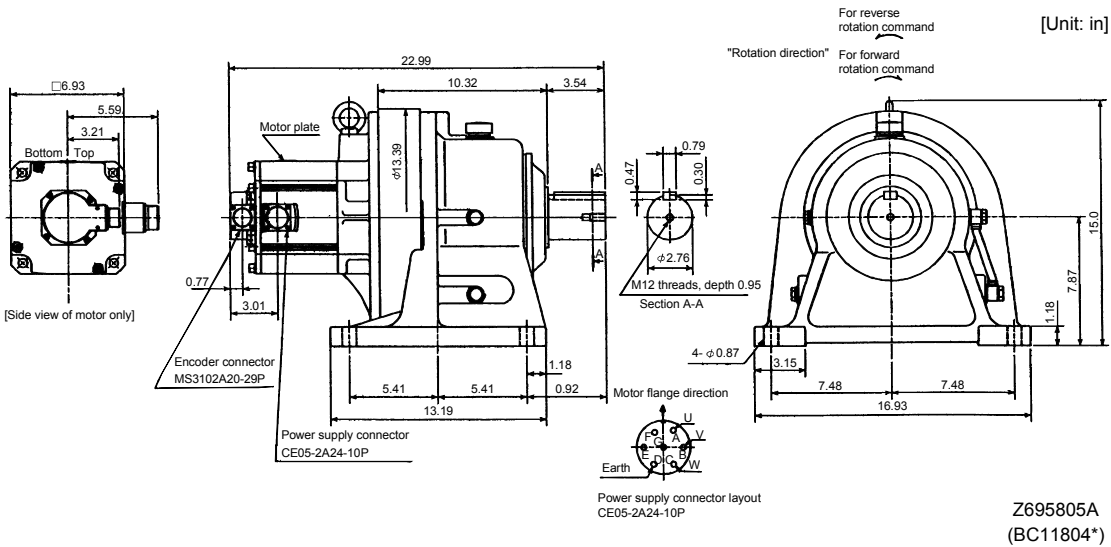

7. OUTLINE DIMENSION DRAWINGS

Model		Output [kW]	Reduction Ratio	Inertia Moment WK^2 [oz · in ²]	Mass [lb]
HC-SF502G1H	HC-SFS502G1H HC-SFS5024G1H	5.0	1/11	620.01	225
HC-SF502G1H	HC-SFS502G1H HC-SFS5024G1H	5.0	1/17	598.14	225

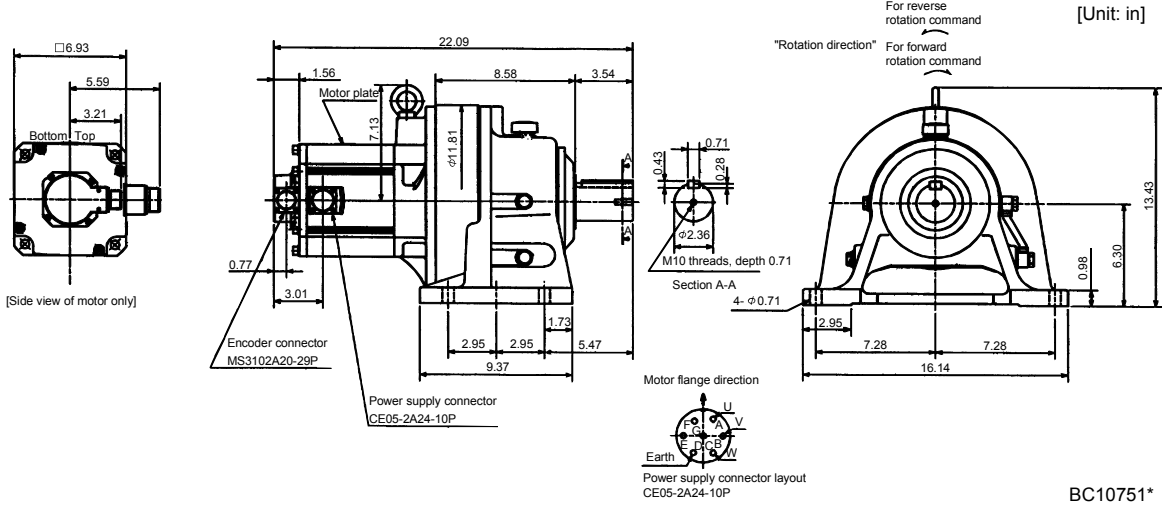

Model		Output [kW]	Reduction Ratio	Inertia Moment WK^2 [oz · in ²]	Mass [lb]
HC-SF502G1H	HC-SFS502G1H HC-SFS5024G1H	5.0	1/29	757.24	377
HC-SF502G1H	HC-SFS502G1H HC-SFS5024G1H	5.0	1/35	754.51	377
HC-SF502G1H	HC-SFS502G1H HC-SFS5024G1H	5.0	1/43	749.04	377

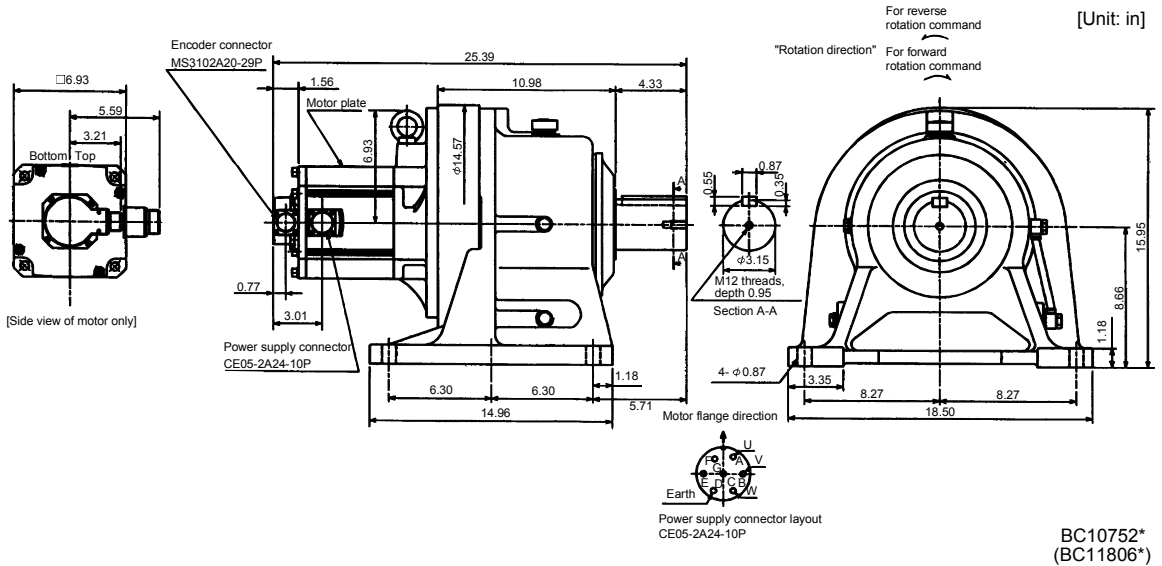

7. OUTLINE DIMENSION DRAWINGS

Model		Output [kW]	Reduction Ratio	Inertia Moment WK^2 [oz · in ²]	Mass [lb]
HC-SF702G1H	HC-SFS702G1H HC-SFS7024G1H	7.0	1/11	1086.93	304
HC-SF702G1H	HC-SFS702G1H HC-SFS7024G1H	7.0	1/17	1038.82	304

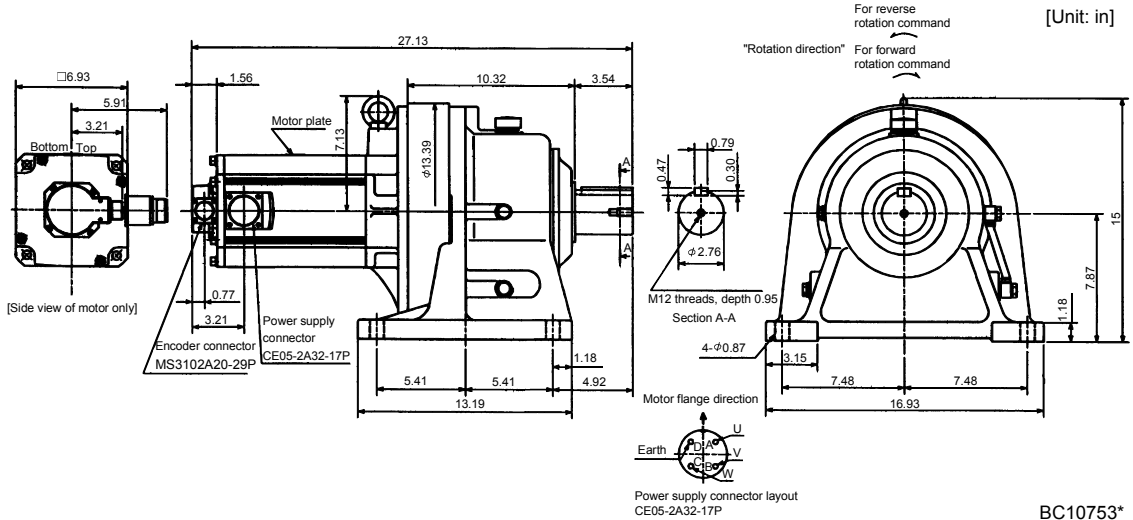

Model		Output [kW]	Reduction Ratio	Inertia Moment WK^2 [oz · in ²]	Mass [lb]
HC-SF702G1H	HC-SFS702G1H HC-SFS7024G1H	7.0	1/29	1079.82	397
HC-SF702G1H	HC-SFS702G1H HC-SFS7024G1H	7.0	1/35	1077.09	397

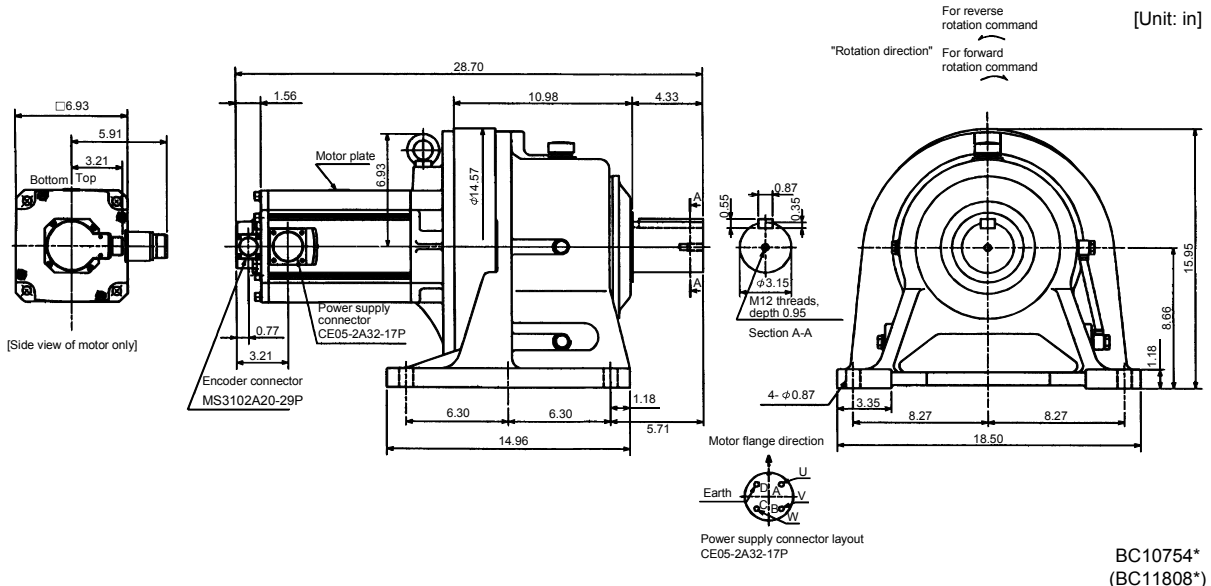

7. OUTLINE DIMENSION DRAWINGS

Model	Output [kW]	Reduction Ratio	Inertia Moment WK^2 [oz · in ²]	Mass [lb]
HC-SF702G1H HC-SFS702G1H HC-SFS7024G1H	7.0	1/43	1404.04	575

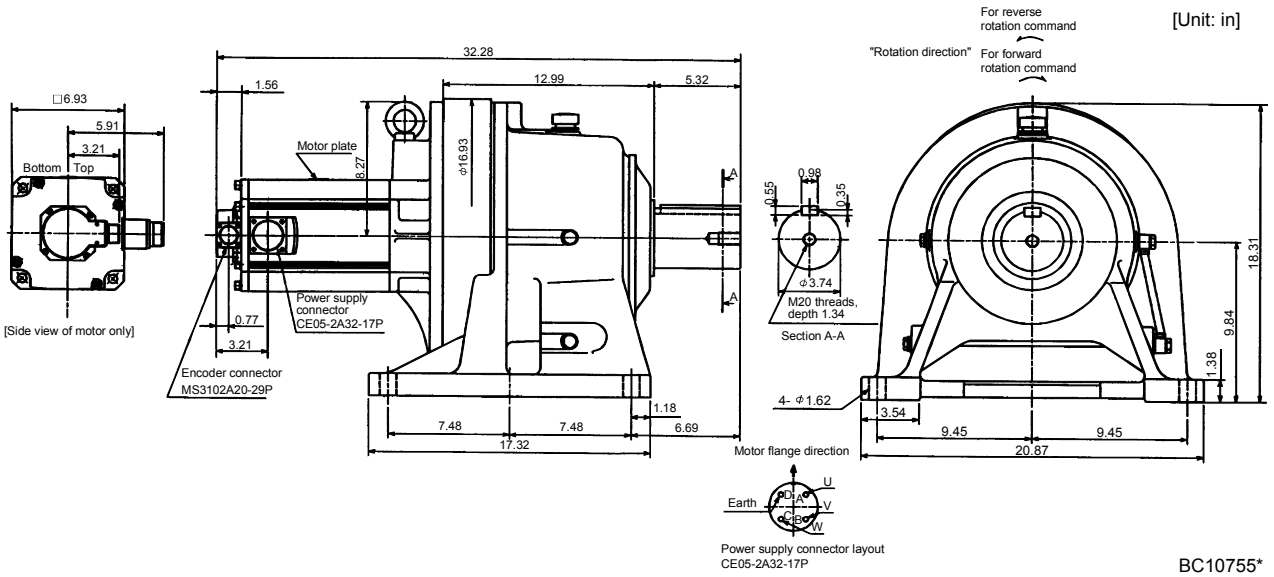

7. OUTLINE DIMENSION DRAWINGS

(b) With electromagnetic brake

Model			Output [kW]	Reduction Ratio	Inertia Moment WK ² [oz · in ²]	Variable Dimensions [in]	Mass [lb]	Brake static friction torque [oz · in]
						L		
HC-SF52BG1H	HC-SFS52BG1H	HC-SFS524BG1H	0.5	1/35	50.3	14.61	72.8	1175
HC-SF52BG1H	HC-SFS52BG1H	HC-SFS524BG1H	0.5	1/43	50.03	14.61	72.8	1175
HC-SF52BG1H	HC-SFS52BG1H	HC-SFS524BG1H	0.5	1/59	49.89	14.61	72.8	1175
HC-SF102BG1H	HC-SFS102BG1H	HC-SFS1024BG1H	1.0	1/6	101.15	15.59	77.2	1175
HC-SF102BG1H	HC-SFS102BG1H	HC-SFS1024BG1H	1.0	1/11	92.9	15.59	77.2	1175
HC-SF102BG1H	HC-SFS102BG1H	HC-SFS1024BG1H	1.0	1/17	90.76	15.59	77.2	1175
HC-SF102BG1H	HC-SFS102BG1H	HC-SFS1024BG1H	1.0	1/29	89.12	15.59	77.2	1175
HC-SF102BG1H	HC-SFS102BG1H	HC-SFS1024BG1H	1.0	1/35	89.1	15.59	77.2	1175
HC-SF152BG1H	HC-SFS152BG1H	HC-SFS1524BG1H	1.5	1/6	135.6	16.58	81.6	1175
HC-SF152BG1H	HC-SFS152BG1H	HC-SFS1524BG1H	1.5	1/11	126.85	16.58	81.6	1175
HC-SF152BG1H	HC-SFS152BG1H	HC-SFS1524BG1H	1.5	1/17	125.2	16.58	81.6	1175

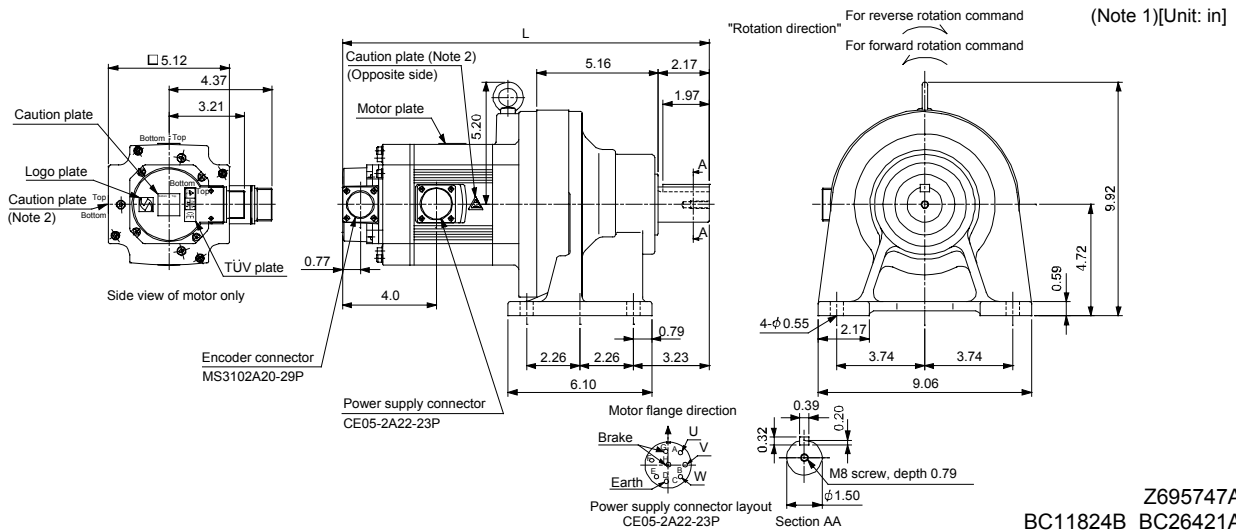

Note 1. The dimensions without tolerances are reference dimensions.
 2. This caution plate is attached to the 400V class motors only, not to the 200V class.

Model			Output [kW]	Reduction Ratio	Inertia Moment WK ² [oz · in ²]	Mass [lb]	Brake static friction torque [oz · in]
HC-SF52BG1H	HC-SFS52BG1H	HC-SFS524BG1H	0.5	1/6	49.34	50.7	1175
HC-SF52BG1H	HC-SFS52BG1H	HC-SFS524BG1H	0.5	1/11	47.29	50.7	1175
HC-SF52BG1H	HC-SFS52BG1H	HC-SFS524BG1H	0.5	1/17	46.75	50.7	1175
HC-SF52BG1H	HC-SFS52BG1H	HC-SFS524BG1H	0.5	1/29	46.34	50.7	1175

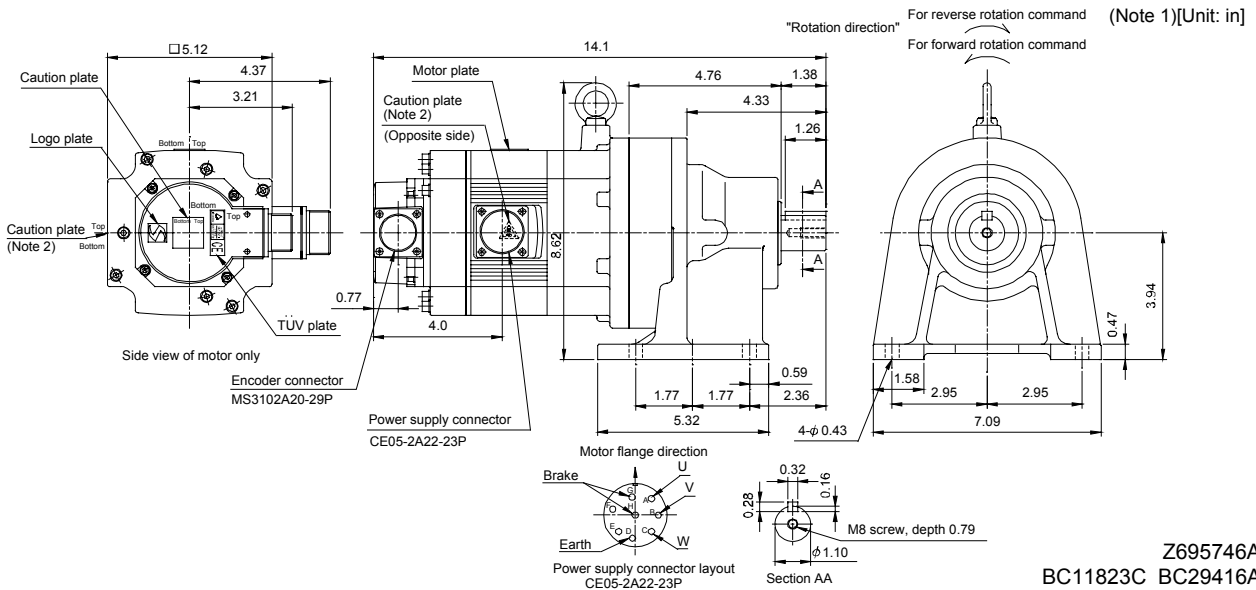

Note 1. The dimensions without tolerances are reference dimensions.
 2. This caution plate is attached to the 400V class motors only, not to the 200V class.

7. OUTLINE DIMENSION DRAWINGS

Model	Output [kW]	Reduction Ratio	Inertia Moment WK^2 [oz · in ²]	Variable Dimensions [in]	Mass [lb]	Brake static friction torque [oz · in]
				L		
HC-SF102BG1H HC-SFS1024BG1H	1.0	1/59	115.80	20.51	202.8	1175
HC-SF152BG1H HC-SFS1524BG1H	1.5	1/43	150.36	21.50	207.2	1175
HC-SF152BG1H HC-SFS1524BG1H	1.5	1/59	149.97	21.50	207.2	1175

[Unit: in]

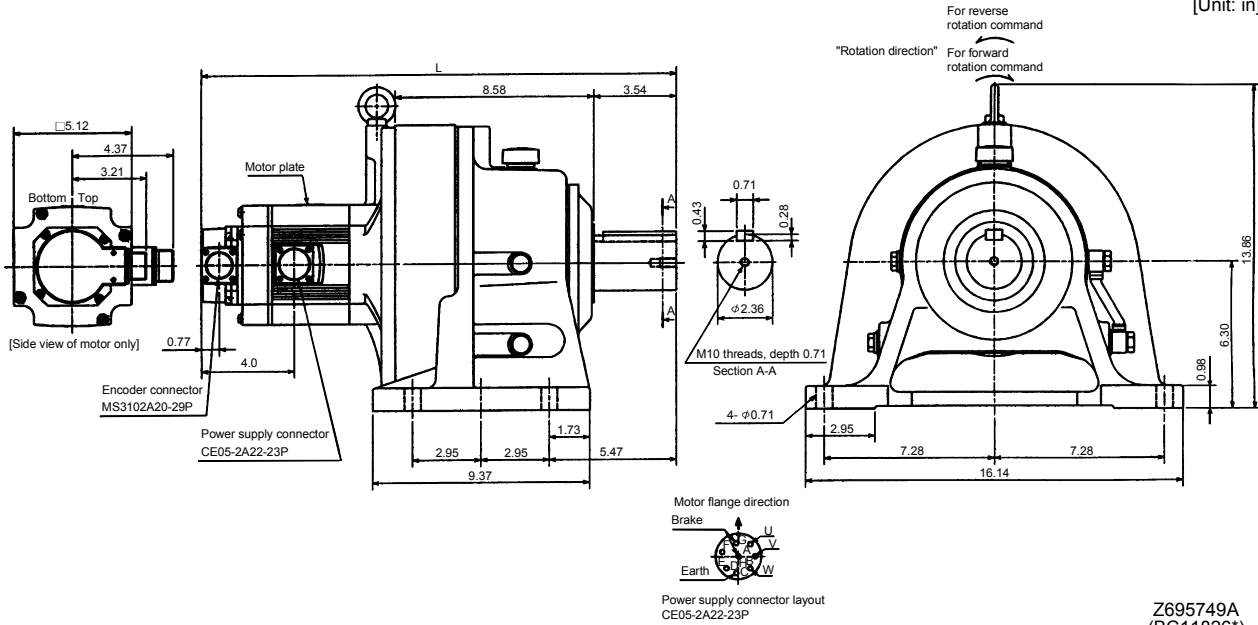

Model	Output [kW]	Reduction Ratio	Inertia Moment WK^2 [oz · in ²]	Variable Dimensions [in]	Mass [lb]	Brake static friction torque [oz · in]
				L		
HC-SF102BG1H HC-SFS1024BG1H	1.0	1/43	94.86	17.68	116.8	1175
HC-SF152BG1H HC-SFS1524BG1H	1.5	1/29	130.02	18.66	121.3	1175
HC-SF152BG1H HC-SFS1524BG1H	1.5	1/35	129.74	18.66	121.3	1175

[Unit: in]

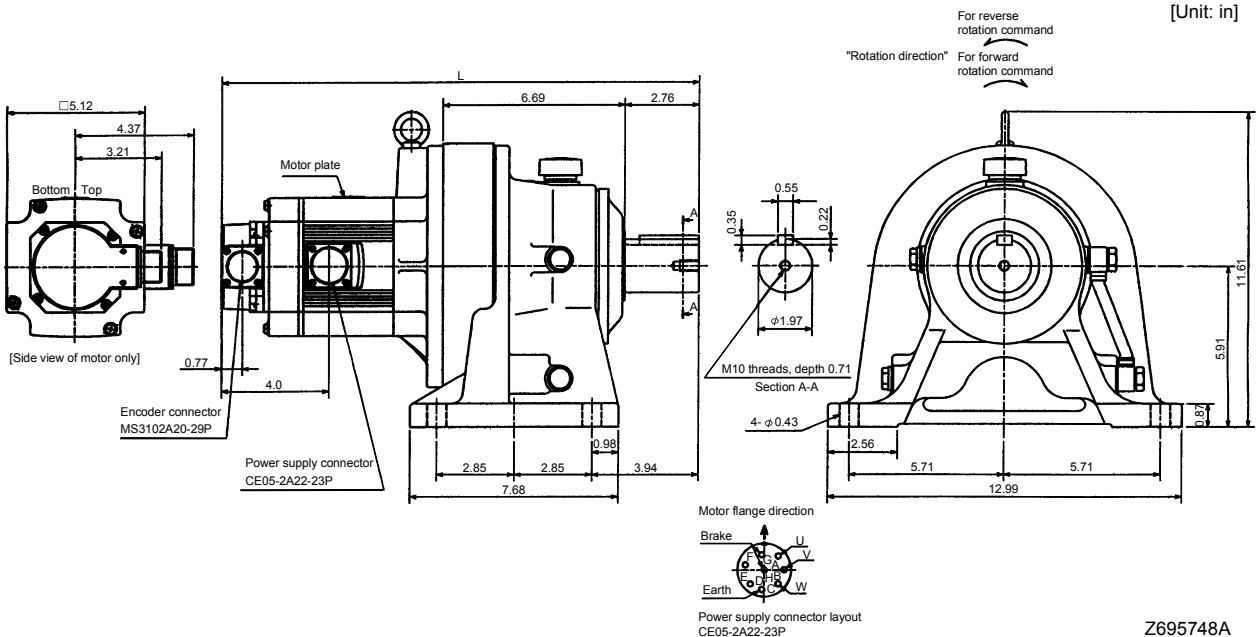

7. OUTLINE DIMENSION DRAWINGS

Model	Output [kW]	Reduction Ratio	Inertia Moment WK ² [oz · in ²]	Mass [lb]	Brake static friction torque [oz · in]
HC-SF202BG1H HC-SFS202BG1H HC-SFS2024BG1H	2.0	1/6	303.99	90.4	6103
HC-SF202BG1H HC-SFS202BG1H HC-SFS2024BG1H	2.0	1/11	295.79	90.4	6103
HC-SF202BG1H HC-SFS202BG1H HC-SFS2024BG1H	2.0	1/17	293.60	90.4	6103

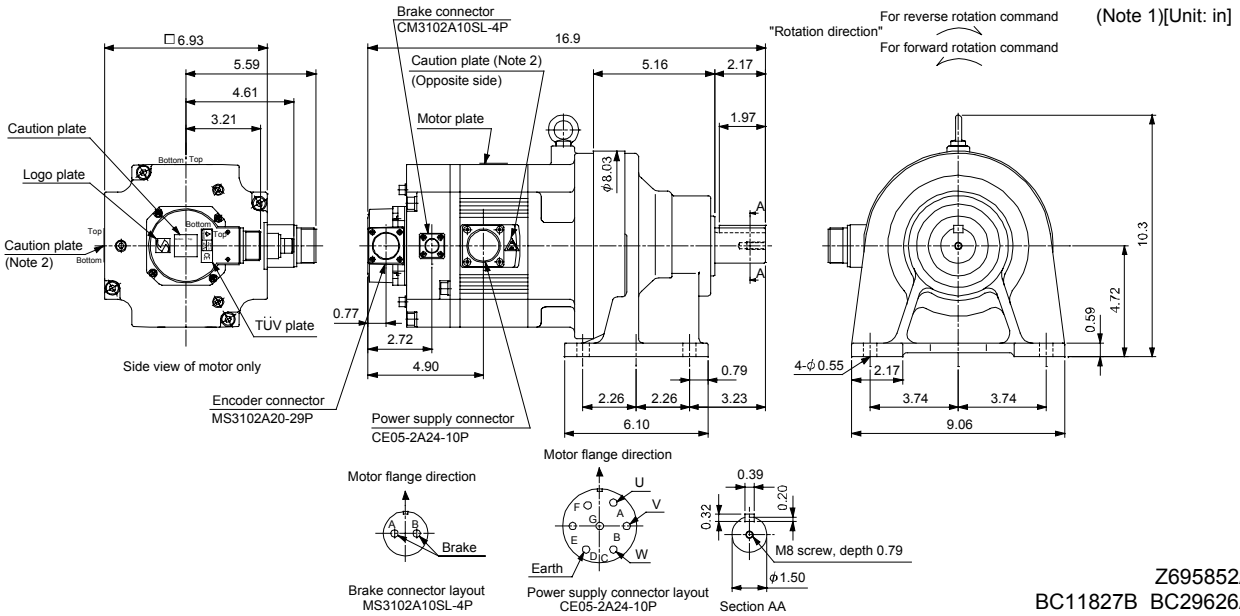

Z695852A
BC11827B BC29626A

Note 1. The dimensions without tolerances are reference dimensions.
2. This caution plate is attached to the 400V class motors only, not to the 200V class.

Model	Output [kW]	Reduction Ratio	Inertia Moment WK ² [oz · in ²]	Mass [lb]	Brake static friction torque [oz · in]
HC-SF352BG1H HC-SFS352BG1H HC-SFS3524BG1H	3.5	1/6	547.29	145.5	6103
HC-SF352BG1H HC-SFS352BG1H HC-SFS3524BG1H	3.5	1/11	525.97	145.5	6103
HC-SF352BG1H HC-SFS352BG1H HC-SFS3524BG1H	3.5	1/17	519.41	145.5	6103

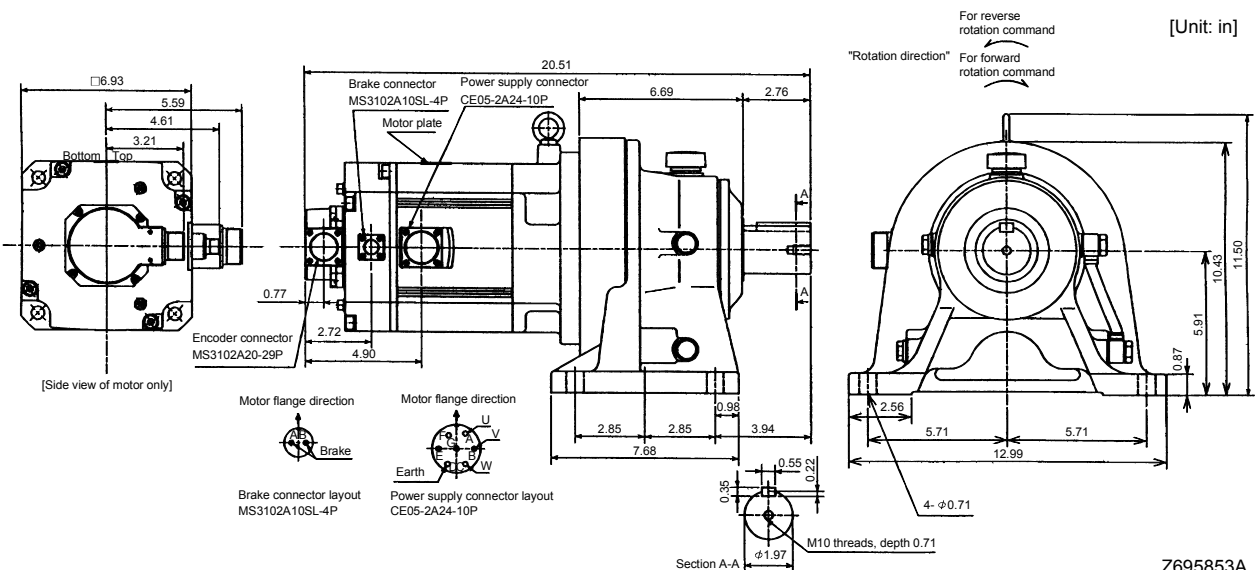

Z695853A
(BC11829*)

7. OUTLINE DIMENSION DRAWINGS

Model		Output [kW]	Reduction Ratio	Inertia Moment WK ² [oz · in ²]	Variable Dimensions [in]	Mass [lb]	Brake static friction torque [oz · in]
					L		
HC-SF202BG1H	HC-SFS202BG1H HC-SFS2024BG1H	2.0	1/29	322.03	21.50	213.8	6103
HC-SF202BG1H	HC-SFS202BG1H HC-SFS2024BG1H	2.0	1/35	320.39	21.50	213.8	6103
HC-SF202BG1H	HC-SFS202BG1H HC-SFS2024BG1H	2.0	1/43	319.30	21.50	213.8	6103
HC-SF202BG1H	HC-SFS202BG1H HC-SFS2024BG1H	2.0	1/59	318.75	21.50	213.8	6103
HC-SF352BG1H	HC-SFS352BG1H HC-SFS3524BG1H	3.5	1/29	538.8	23.15	229.3	6103
HC-SF352BG1H	HC-SFS352BG1H HC-SFS3524BG1H	3.5	1/35	536.36	23.15	229.3	6103

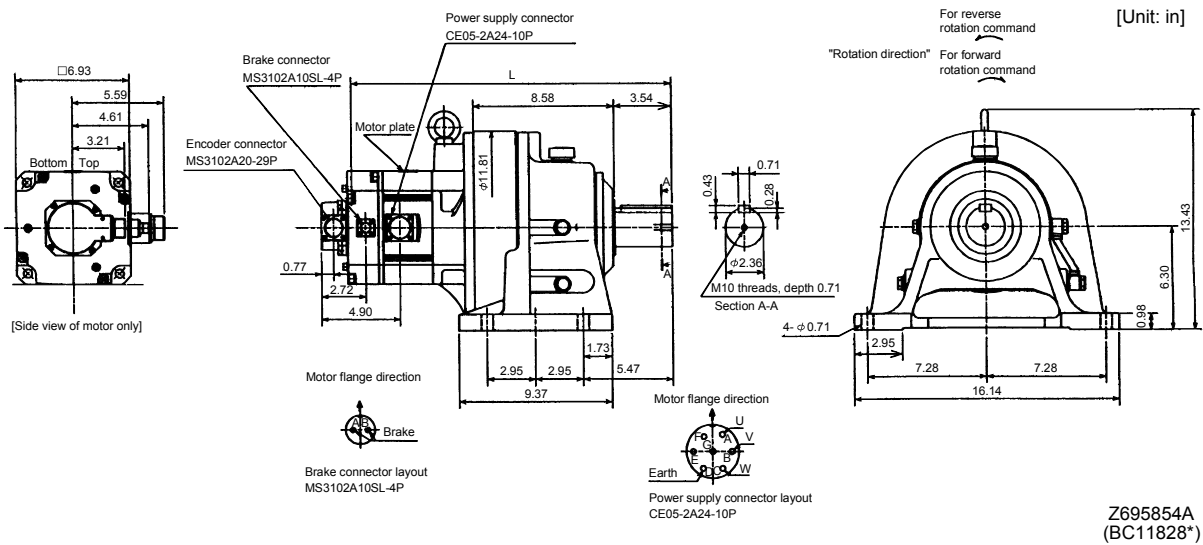

Model		Output [kW]	Reduction Ratio	Inertia Moment WK ² [oz · in ²]	Mass [lb]	Brake static friction torque [oz · in]
HC-SF352BG1H	HC-SFS352BG1H HC-SFS3524BG1H					
HC-SF352BG1H	HC-SFS352BG1H HC-SFS3524BG1H	3.5	1/59	633.68	319.7	6103

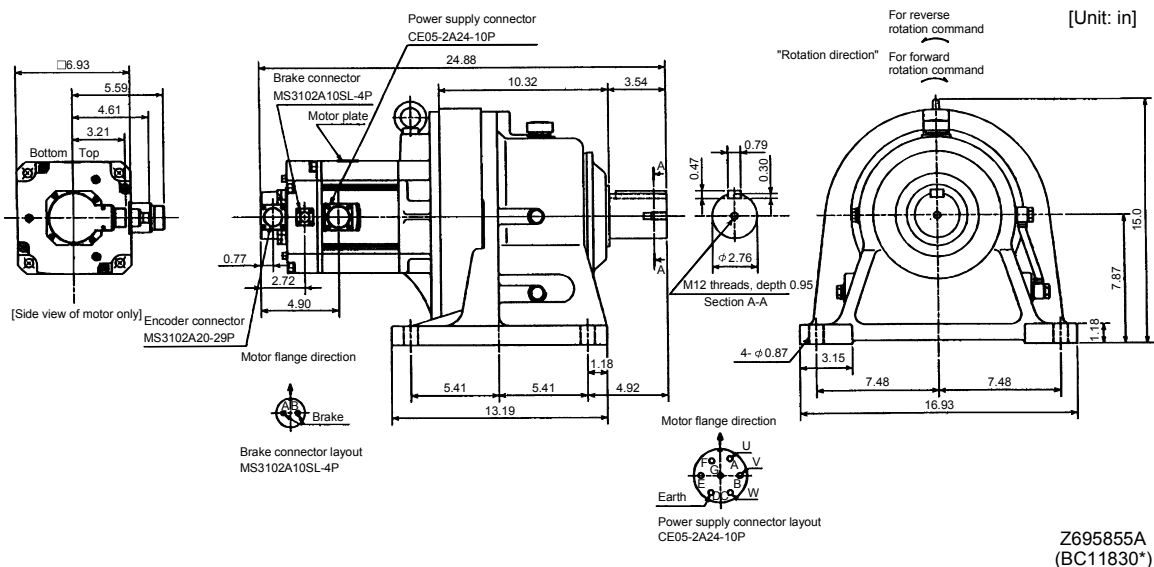

7. OUTLINE DIMENSION DRAWINGS

Model		Output [kW]	Reduction Ratio	Inertia Moment WK ² [oz · in ²]	Mass [lb]	Brake static friction torque [oz · in]
HC-SF502BG1H	HC-SFS502BG1H HC-SFS5024BG1H	5.0	1/11	674.68	238.1	6103
HC-SF502BG1H	HC-SFS502BG1H HC-SFS5024BG1H	5.0	1/17	652.81	238.1	6103

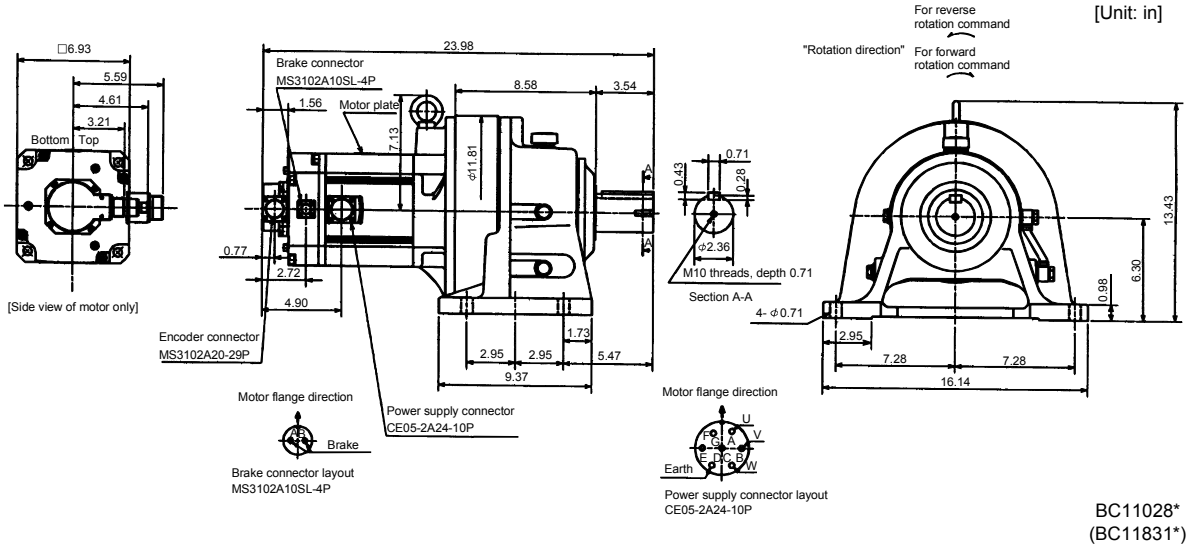

Model		Output [kW]	Reduction Ratio	Inertia Moment WK ² [oz · in ²]	Mass [lb]	Brake static friction torque [oz · in]
HC-SF502BG1H	HC-SFS502BG1H HC-SFS5024BG1H	5.0	1/29	811.92	390.2	6103
HC-SF502BG1H	HC-SFS502BG1H HC-SFS5024BG1H	5.0	1/35	809.18	390.2	6103
HC-SF502BG1H	HC-SFS502BG1H HC-SFS5024BG1H	5.0	1/43	803.71	390.2	6103

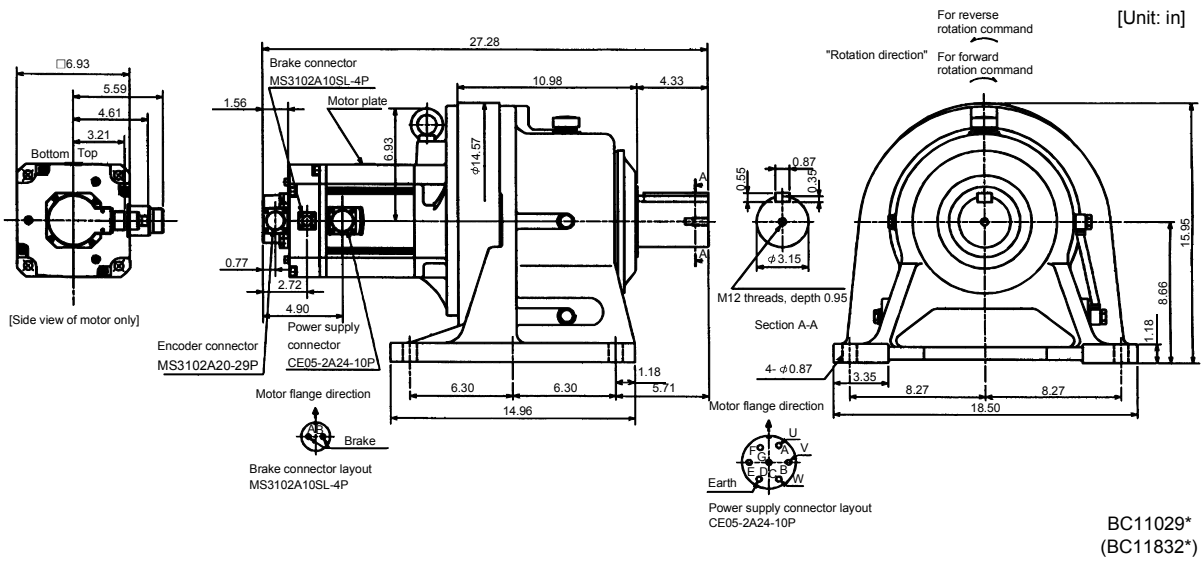

7. OUTLINE DIMENSION DRAWINGS

Model		Output [kW]	Reduction Ratio	Inertia Moment WK^2 [oz · in ²]	Mass [lb]	Brake static friction torque [oz · in]
HC-SF702BG1H	HC-SFS702BG1H HC-SFS7024BG1H	7.0	1/11	1141.60	317.5	6103
HC-SF702BG1H	HC-SFS702BG1H HC-SFS7024BG1H	7.0	1/17	1093.49	317.5	6103

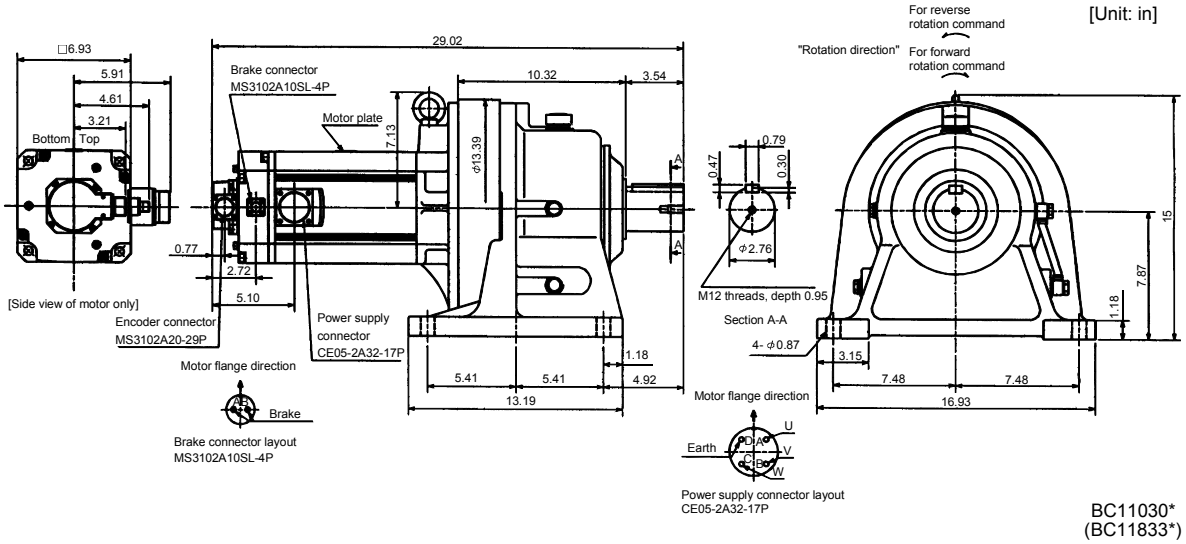

Model		Output [kW]	Reduction Ratio	Inertia Moment WK^2 [oz · in ²]	Mass [lb]	Brake static friction torque [oz · in]
HC-SF702BG1H	HC-SFS702BG1H HC-SFS7024BG1H	7.0	1/29	1134.50	410.1	6103
HC-SF702BG1H	HC-SFS702BG1H HC-SFS7024BG1H	7.0	1/35	1131.76	410.1	6103

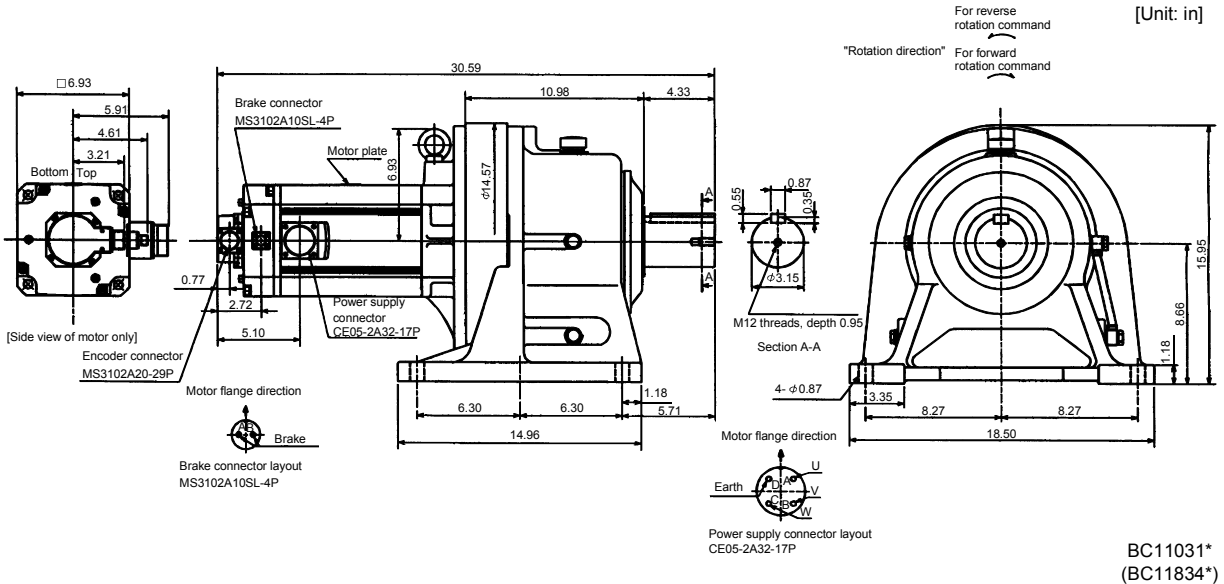

7. OUTLINE DIMENSION DRAWINGS

Model	Output [kW]	Reduction Ratio	Inertia Moment WK ² [oz · in ²]	Mass [lb]	Brake static friction torque [oz · in]
HC-SF702BG1H HC-SFS702BG1H HC-SFS7024BG1H	7.0	1/43	1458.71	588.6	6103

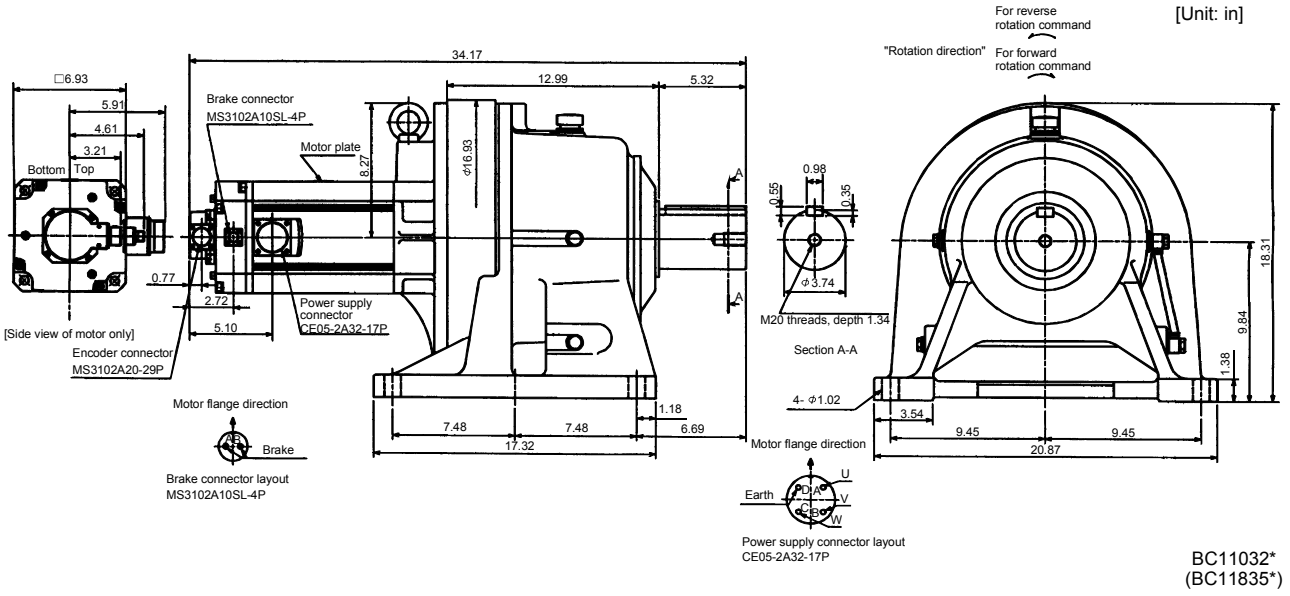

BC11032*
(BC11835*)

7. OUTLINE DIMENSION DRAWINGS

(4) With reduction gear for general industrial machine (flange type)

The outer frame of the reduction gear is a material surface such as casting. Its actual dimensions may be 0.039 to 0.118 in larger than the drawing dimensions. Design the machine side with allowances.

(a) Without electromagnetic brake

Model			Output [kW]	Reduction Ratio	Inertia Moment WK ² [oz · in ²]	Variable Dimensions [in]		Mass [lb]
						L		
HC-SF52G1	HC-SFS52G1	HC-SFS524G1	0.5	1/35	41.01	10.59	59.5	
HC-SF52G1	HC-SFS52G1	HC-SFS524G1	0.5	1/43	40.73	10.59	59.5	
HC-SF52G1	HC-SFS52G1	HC-SFS524G1	0.5	1/59	40.60	10.59	59.5	
HC-SF102G1	HC-SFS102G1	HC-SFS1024G1	1.0	1/6	91.85	11.58	63.9	
HC-SF102G1	HC-SFS102G1	HC-SFS1024G1	1.0	1/11	83.7	11.58	63.9	
HC-SF102G1	HC-SFS102G1	HC-SFS1024G1	1.0	1/17	81.47	11.58	63.9	
HC-SF102G1	HC-SFS102G1	HC-SFS1024G1	1.0	1/29	79.83	11.58	63.9	
HC-SF102G1	HC-SFS102G1	HC-SFS1024G1	1.0	1/35	79.8	11.58	63.9	
HC-SF152G1	HC-SFS152G1	HC-SFS1524G1	1.5	1/6	126.3	12.56	68.3	
HC-SF152G1	HC-SFS152G1	HC-SFS1524G1	1.5	1/11	117.55	12.56	68.3	
HC-SF152G1	HC-SFS152G1	HC-SFS1524G1	1.5	1/17	115.9	12.56	68.3	

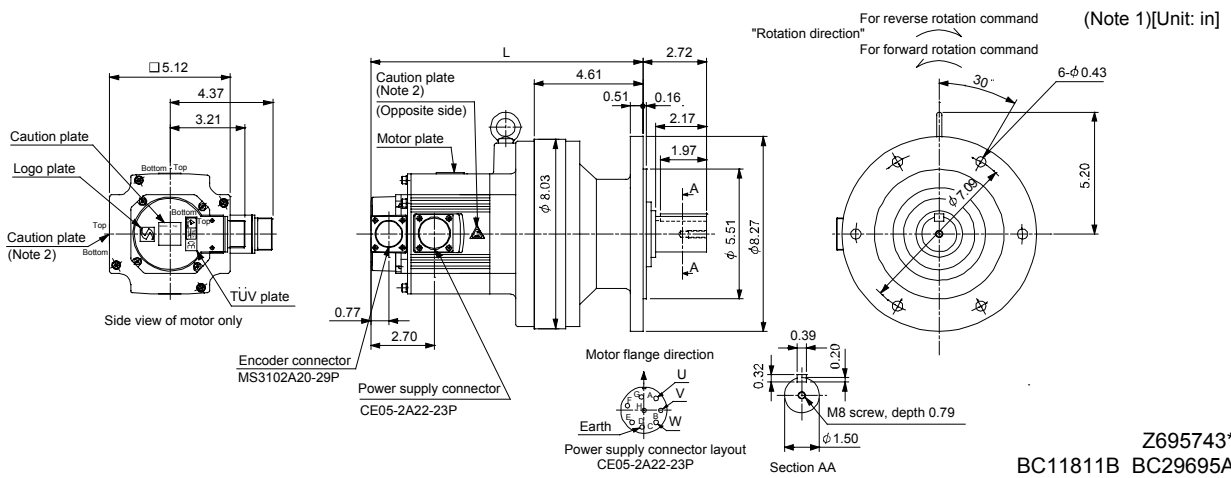

Note 1. The dimensions without tolerances are reference dimensions.
2. This caution plate is attached to the 400V class motors only, not to the 200V class.

Model			Output [kW]	Reduction Ratio	Inertia Moment WK ² [oz · in ²]	Mass [lb]
HC-SF52G1	HC-SFS52G1	HC-SFS524G1				
HC-SF52G1	HC-SFS52G1	HC-SFS524G1	0.5	1/11	38.00	40.8
HC-SF52G1	HC-SFS52G1	HC-SFS524G1	0.5	1/17	37.45	40.8
HC-SF52G1	HC-SFS52G1	HC-SFS524G1	0.5	1/29	37.04	40.8

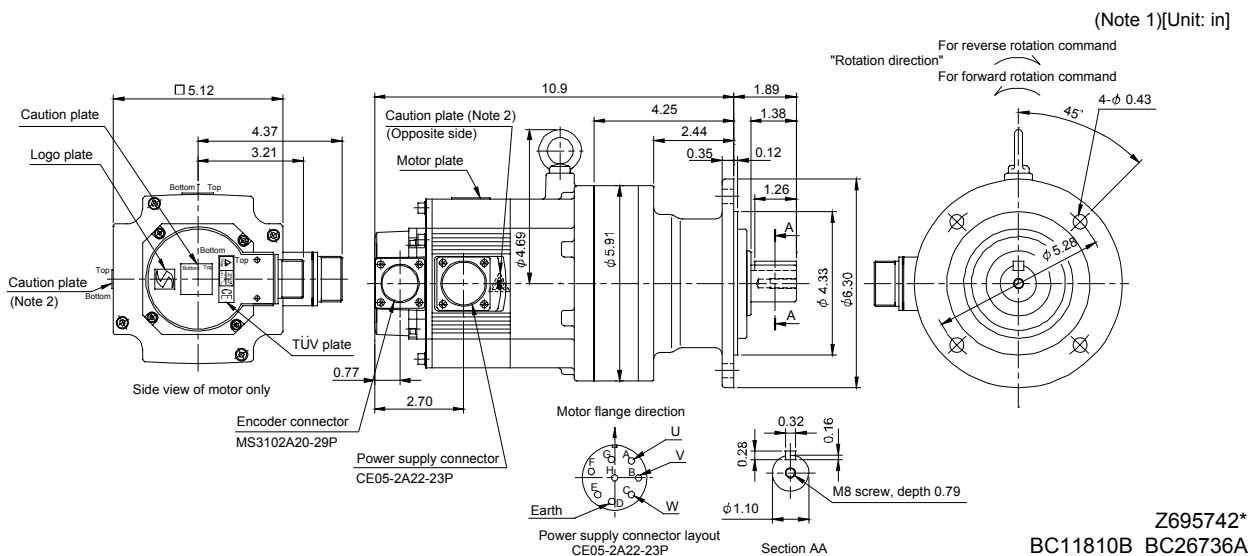

Note 1. The dimensions without tolerances are reference dimensions.
2. This caution plate is attached to the 400V class motors only, not to the 200V class.

7. OUTLINE DIMENSION DRAWINGS

Model		Output [kW]	Reduction Ratio	Inertia Moment WK^2 [oz · in ²]	Variable Dimensions [in]	Mass [lb]
					L	
HC-SF102G1	HC-SFS102G1	1.0	1/59	106.48	13.35	183.0
	HC-SFS1024G1					
HC-SF152G1	HC-SFS152G1	1.5	1/43	141.06	16.69	187.4
	HC-SFS1524G1					
HC-SF152G1	HC-SFS152G1	1.5	1/59	140.65	16.69	187.4
	HC-SFS1524G1					

[Unit: in]

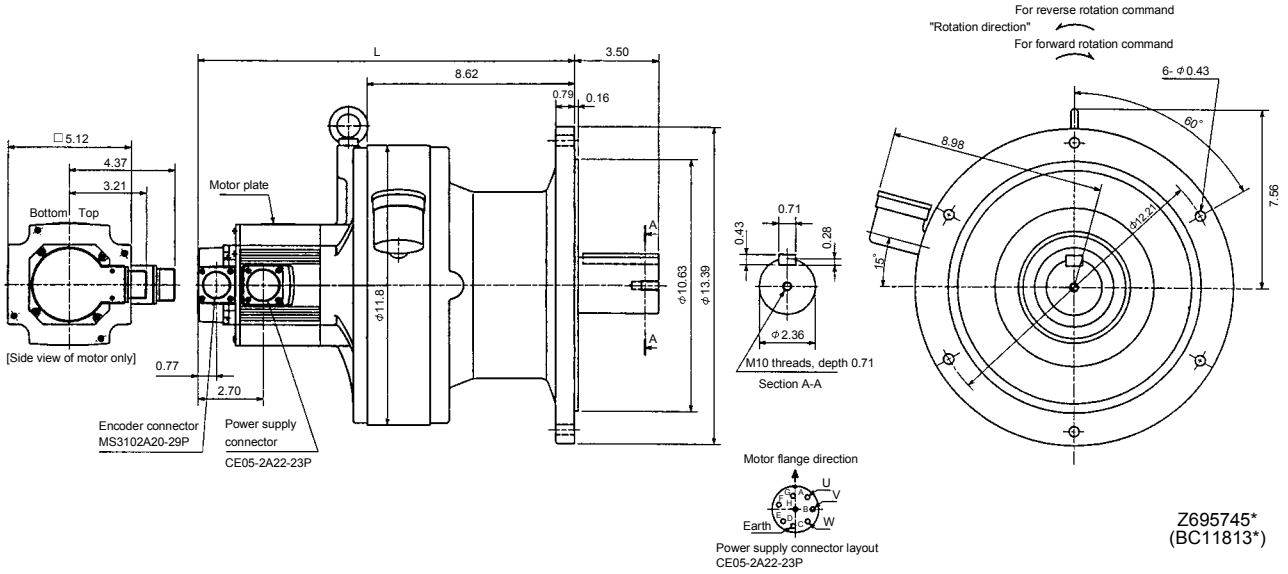

Z695745*
(BC11813*)

Model		Output [kW]	Reduction Ratio	Inertia Moment WK^2 [oz · in ²]	Variable Dimensions [in]	Mass [lb]
					L	
HC-SF102G1	HC-SFS102G1	1.0	1/43	85.57	13.39	105.8
	HC-SFS1024G1					
HC-SF152G1	HC-SFS152G1	1.5	1/29	120.69	14.37	110.2
	HC-SFS1524G1					
HC-SF152G1	HC-SFS152G1	1.5	1/35	120.42	14.37	110.2
	HC-SFS1524G1					

[Unit: in]

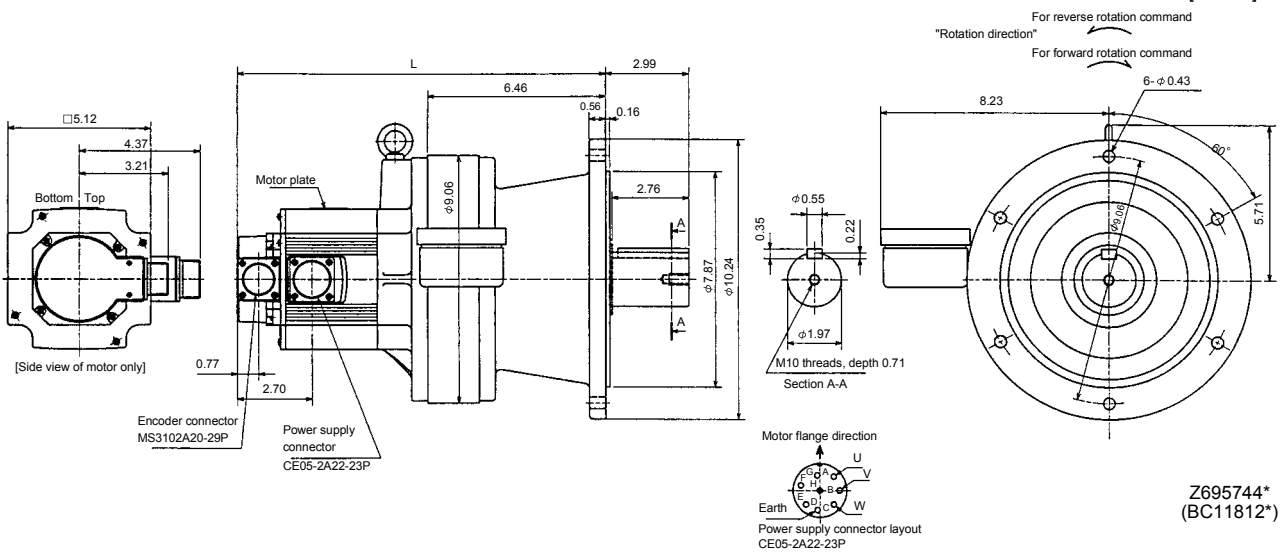

Z695744*
(BC11812*)

7. OUTLINE DIMENSION DRAWINGS

Model	Output [kW]	Reduction Ratio	Inertia Moment WK^2 [oz · in ²]	Mass [lb]
HC-SF202G1 HC-SFS202G1 HC-SFS2024G1	2.0	1/6	249.32	75.0
HC-SF202G1 HC-SFS202G1 HC-SFS2024G1	2.0	1/11	241.11	75.0
HC-SF202G1 HC-SFS202G1 HC-SFS2024G1	2.0	1/17	238.93	75.0

(Note 1)[Unit: in]

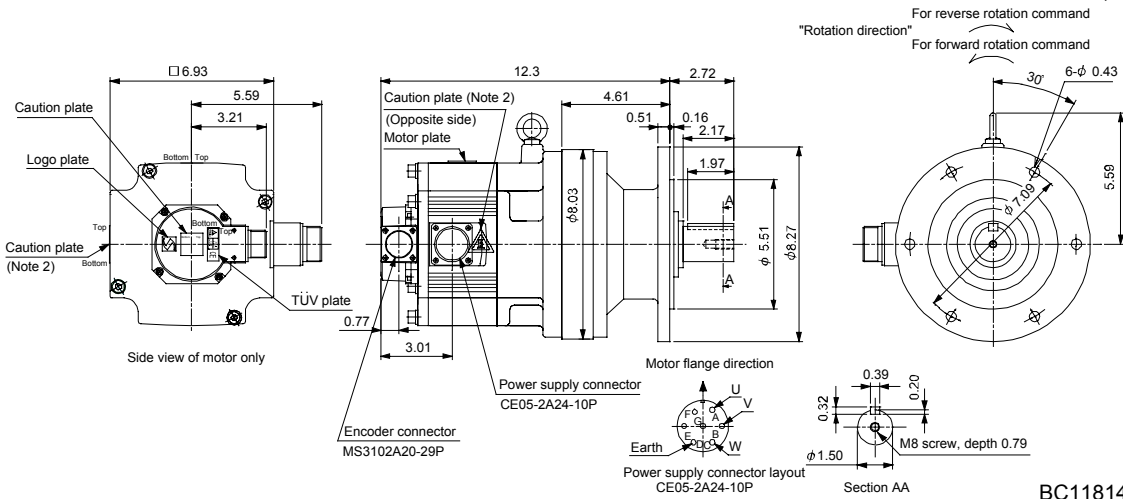

Z695806A
BC11814B BC30689*

Note 1. The dimensions without tolerances are reference dimensions.
2. This caution plate is attached to the 400V class motors only, not to the 200V class.

Model	Output [kW]	Reduction Ratio	Inertia Moment WK^2 [oz · in ²]	Mass [lb]
HC-SF352G1 HC-SFS352G1 HC-SFS3524G1	3.5	1/6	492.62	125.7
HC-SF352G1 HC-SFS352G1 HC-SFS3524G1	3.5	1/11	471.29	125.7
HC-SF352G1 HC-SFS352G1 HC-SFS3524G1	3.5	1/17	464.73	125.7

[Unit: in]

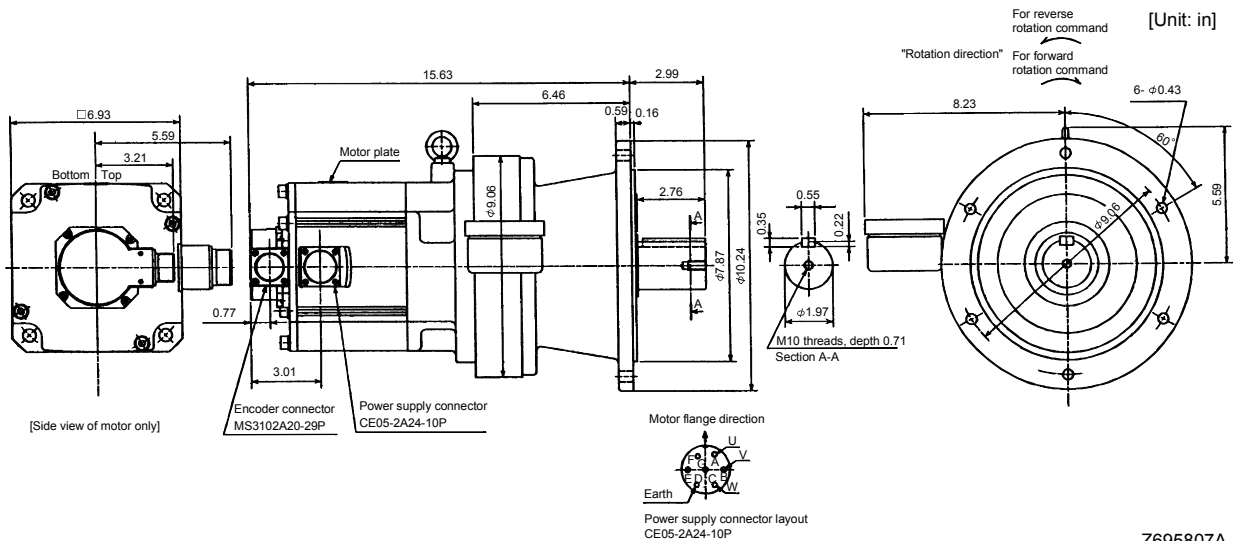

Z695807A
(BC11816*)

7. OUTLINE DIMENSION DRAWINGS

Model	Output [kW]	Reduction Ratio	Inertia Moment WK^2 [oz · in ²]	Variable Dimensions [in]	Mass [lb]
				L	
HC-SF202G1 HC-SFS202G1 HC-SFS2024G1	2.0	1/29	267.36	16.10	185.2
HC-SF202G1 HC-SFS202G1 HC-SFS2024G1	2.0	1/35	265.72	16.10	185.2
HC-SF202G1 HC-SFS202G1 HC-SFS2024G1	2.0	1/43	264.62	16.10	185.2
HC-SF202G1 HC-SFS202G1 HC-SFS2024G1	2.0	1/59	264.08	16.10	185.2
HC-SF352G1 HC-SFS352G1 HC-SFS3524G1	3.5	1/29	483.32	17.76	200.6
HC-SF352G1 HC-SFS352G1 HC-SFS3524G1	3.5	1/35	481.68	17.76	200.6

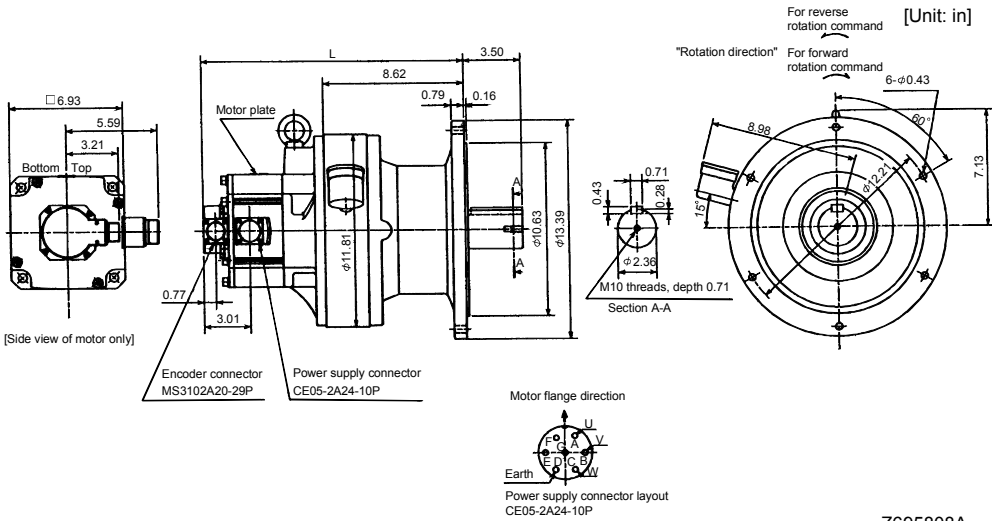

Model	Output [kW]	Reduction Ratio	Inertia Moment WK^2 [oz · in ²]	Mass [lb]
HC-SF352G1 HC-SFS352G1 HC-SFS3524G1	3.5	1/43	582.28	293.2
HC-SF352G1 HC-SFS352G1 HC-SFS3524G1	3.5	1/59	579.0	293.2

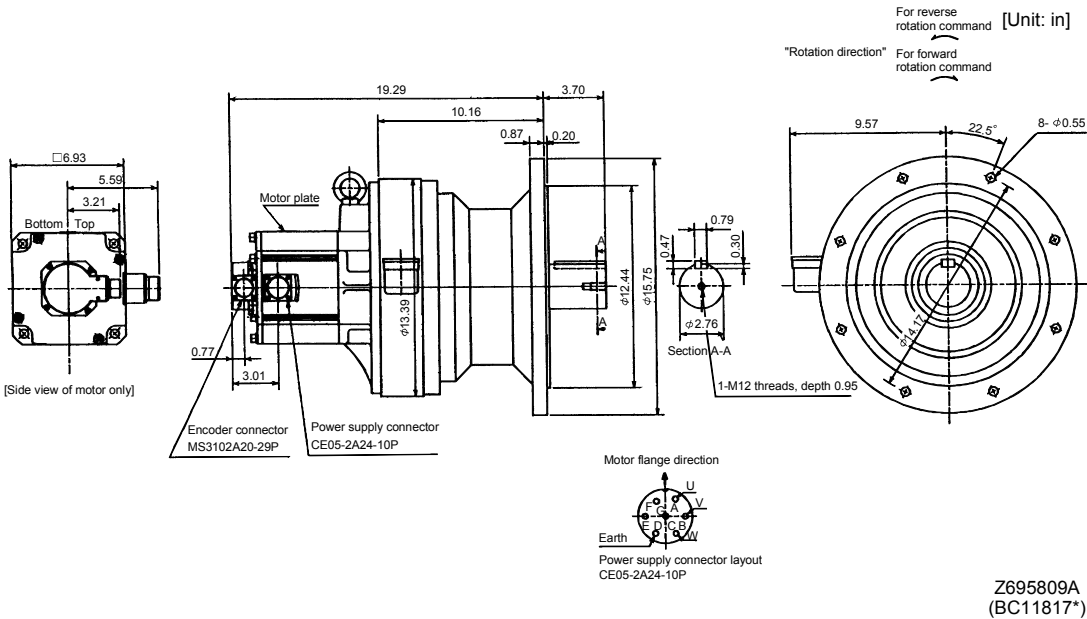

7. OUTLINE DIMENSION DRAWINGS

Model	Output [kW]	Reduction Ratio	Inertia Moment WK ² [oz · in ²]	Mass [lb]
HC-SF502G1 HC-SFS502G1 HC-SFS5024G1	5.0	1/11	620.01	209.4
HC-SF502G1 HC-SFS502G1 HC-SFS5024G1	5.0	1/17	598.14	209.4

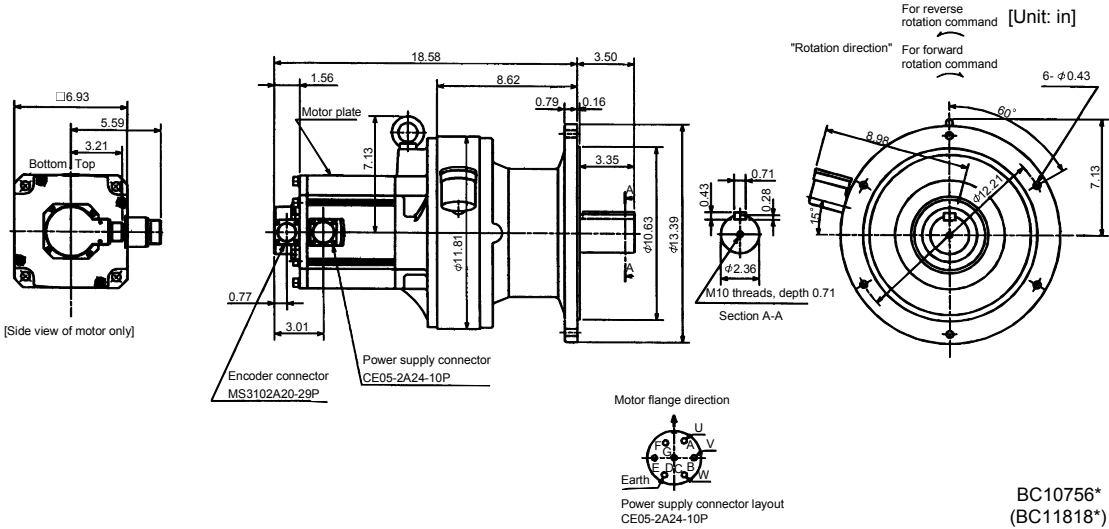

Model	Output [kW]	Reduction Ratio	Inertia Moment WK ² [oz · in ²]	Mass [lb]
HC-SF502G1 HC-SFS502G1 HC-SFS5024G1	5.0	1/29	757.24	357.1
HC-SF502G1 HC-SFS502G1 HC-SFS5024G1	5.0	1/35	754.51	357.1
HC-SF502G1 HC-SFS502G1 HC-SFS5024G1	5.0	1/43	749.04	357.1

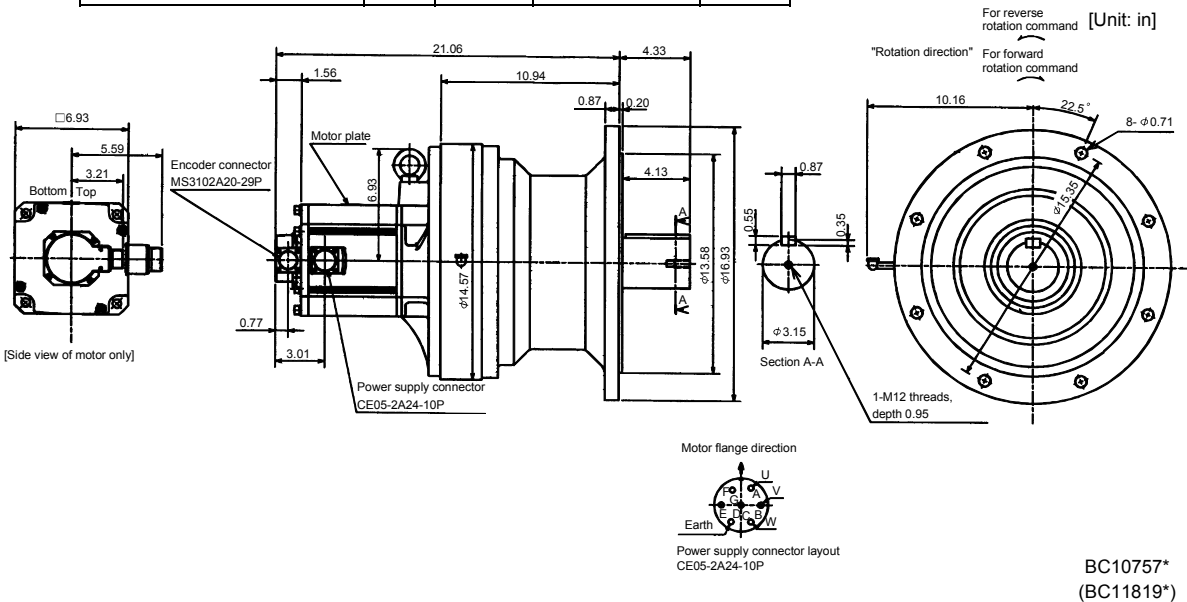

7. OUTLINE DIMENSION DRAWINGS

Model	Output [kW]	Reduction Ratio	Inertia Moment WK^2 [oz · in ²]	Mass [lb]
HC-SF702G1 HC-SFS702G1 HC-SFS7024G1	7.0	1/11	1086.93	321.9
HC-SF702G1 HC-SFS702G1 HC-SFS7024G1	7.0	1/17	1038.82	321.9

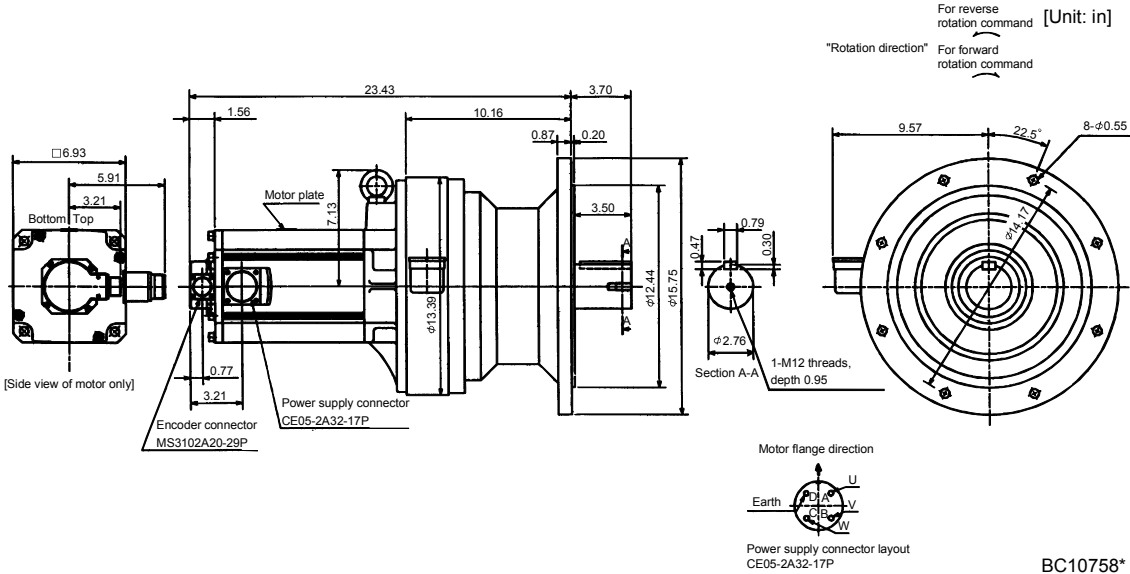

Model	Output [kW]	Reduction Ratio	Inertia Moment WK^2 [oz · in ²]	Mass [lb]
HC-SF702G1 HC-SFS702G1 HC-SFS7024G1	7.0	1/29	1079.82	377.0
HC-SF702G1 HC-SFS702G1 HC-SFS7024G1	7.0	1/35	1077.09	377.0

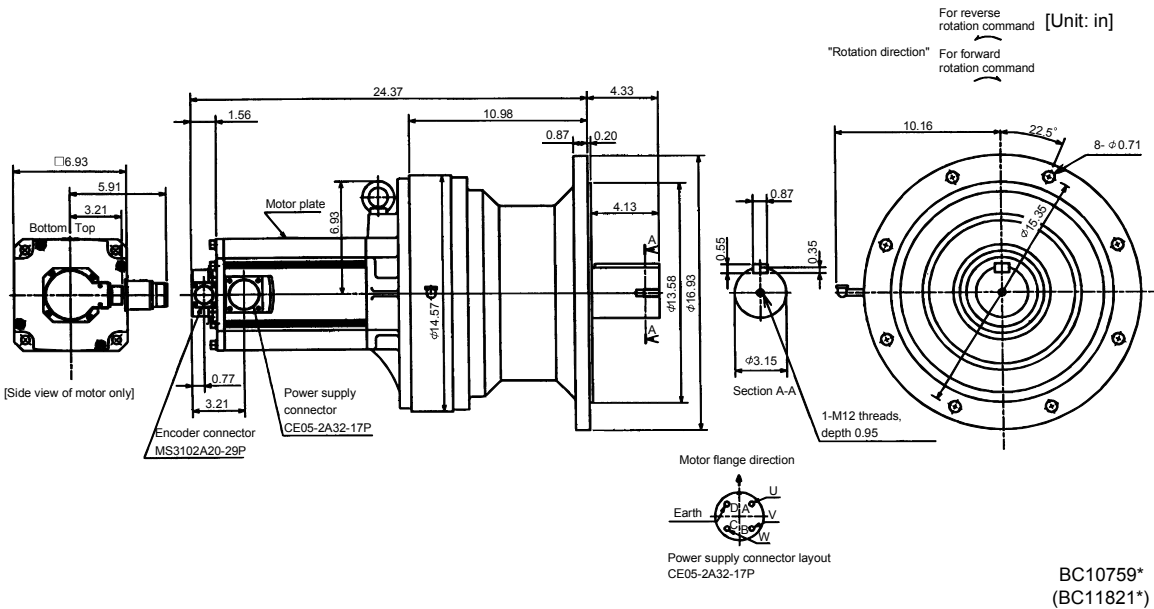

7. OUTLINE DIMENSION DRAWINGS

Model	Output [kW]	Reduction Ratio	Inertia Moment WK ² [oz · in ²]	Mass [lb]
HC-SF702G1	7.0	1/43	1404.04	529.1
HC-SFS702G1 HC-SFS7024G1				

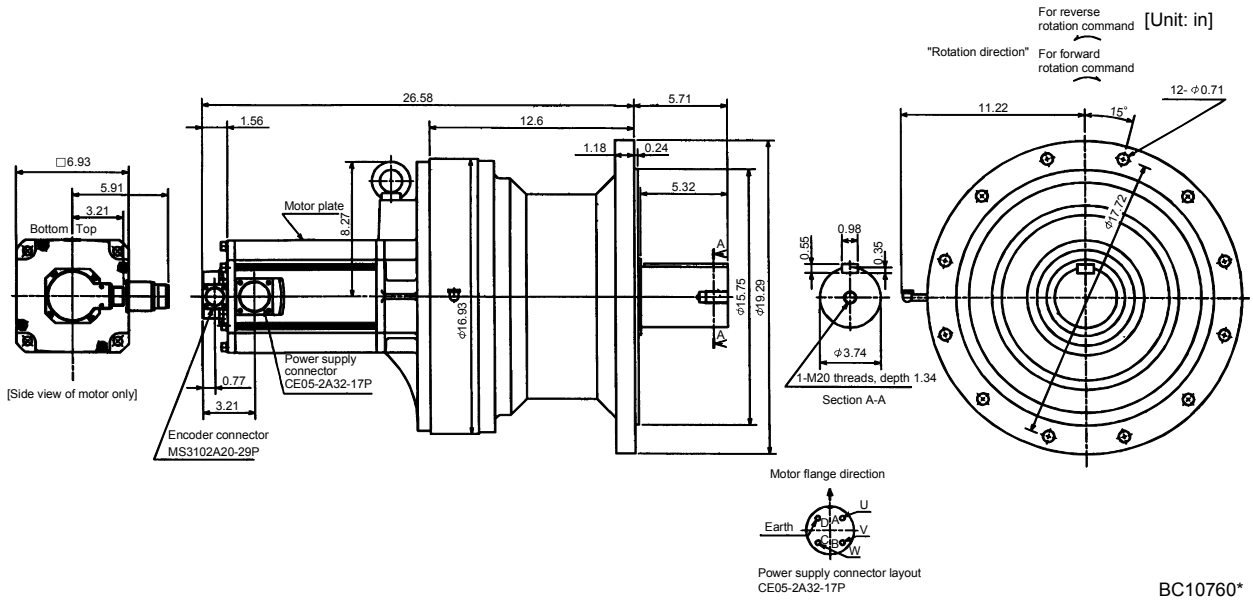

BC10760*
(BC11822*)

7. OUTLINE DIMENSION DRAWINGS

(b) With electromagnetic brake

Model	Output [kW]	Reduction Ratio	Inertia Moment WK ² [oz · in ²]	Variable Dimensions [in]	Mass [lb]	Brake static friction torque [oz · in]
				L		
HC-SF52BG1 HC-SFS52BG1 HC-SFS524BG1	0.5	1/35	50.3	11.89	71.7	1175
HC-SF52BG1 HC-SFS52BG1 HC-SFS524BG1	0.5	1/43	50.03	11.89	71.7	1175
HC-SF52BG1 HC-SFS52BG1 HC-SFS524BG1	0.5	1/59	49.89	11.89	71.7	1175
HC-SF102BG1 HC-SFS102BG1 HC-SFS1024BG1	1.0	1/6	101.15	12.87	76.1	1175
HC-SF102BG1 HC-SFS102BG1 HC-SFS1024BG1	1.0	1/11	92.9	12.87	76.1	1175
HC-SF102BG1 HC-SFS102BG1 HC-SFS1024BG1	1.0	1/17	90.76	12.87	76.1	1175
HC-SF102BG1 HC-SFS102BG1 HC-SFS1024BG1	1.0	1/29	89.12	12.87	76.1	1175
HC-SF102BG1 HC-SFS102BG1 HC-SFS1024BG1	1.0	1/35	89.1	12.87	76.1	1175
HC-SF152BG1 HC-SFS152BG1 HC-SFS1524BG1	1.5	1/6	135.6	13.86	80.5	1175
HC-SF152BG1 HC-SFS152BG1 HC-SFS1524BG1	1.5	1/11	126.85	13.86	80.5	1175
HC-SF152BG1 HC-SFS152BG1 HC-SFS1524BG1	1.5	1/17	125.2	13.86	80.5	1175

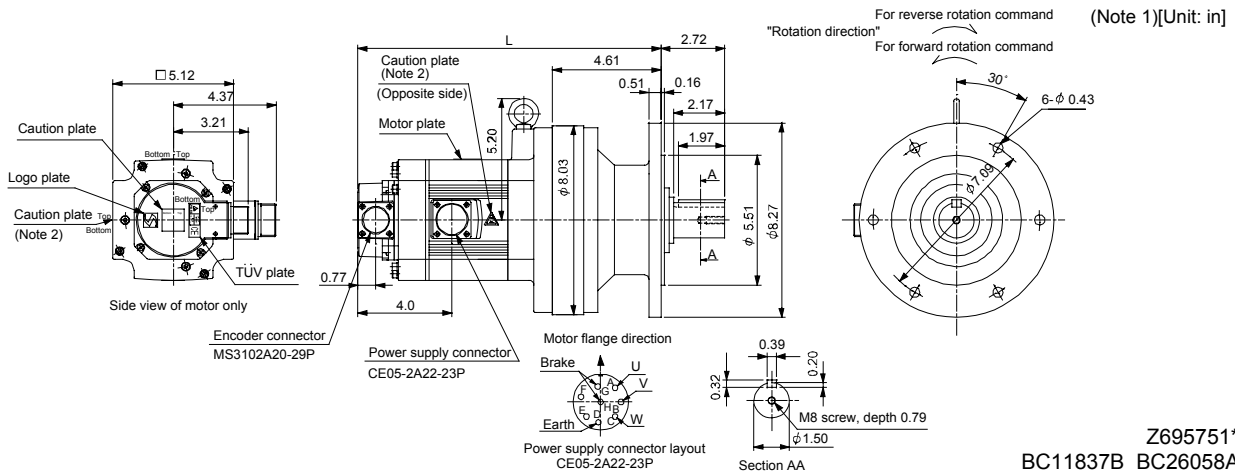

Note 1. The dimensions without tolerances are reference dimensions.
 2. This caution plate is attached to the 400V class motors only, not to the 200V class.

Model	Output [kW]	Reduction Ratio	Inertia Moment WK ² [oz · in ²]	Mass [lb]	Brake static friction torque [oz · in]
HC-SF52BG1 HC-SFS52BG1 HC-SFS524BG1	0.5	1/6	49.34	45.2	1175
HC-SF52BG1 HC-SFS52BG1 HC-SFS524BG1	0.5	1/11	47.29	45.2	1175
HC-SF52BG1 HC-SFS52BG1 HC-SFS524BG1	0.5	1/17	46.75	45.2	1175
HC-SF52BG1 HC-SFS52BG1 HC-SFS524BG1	0.5	1/29	46.34	45.2	1175

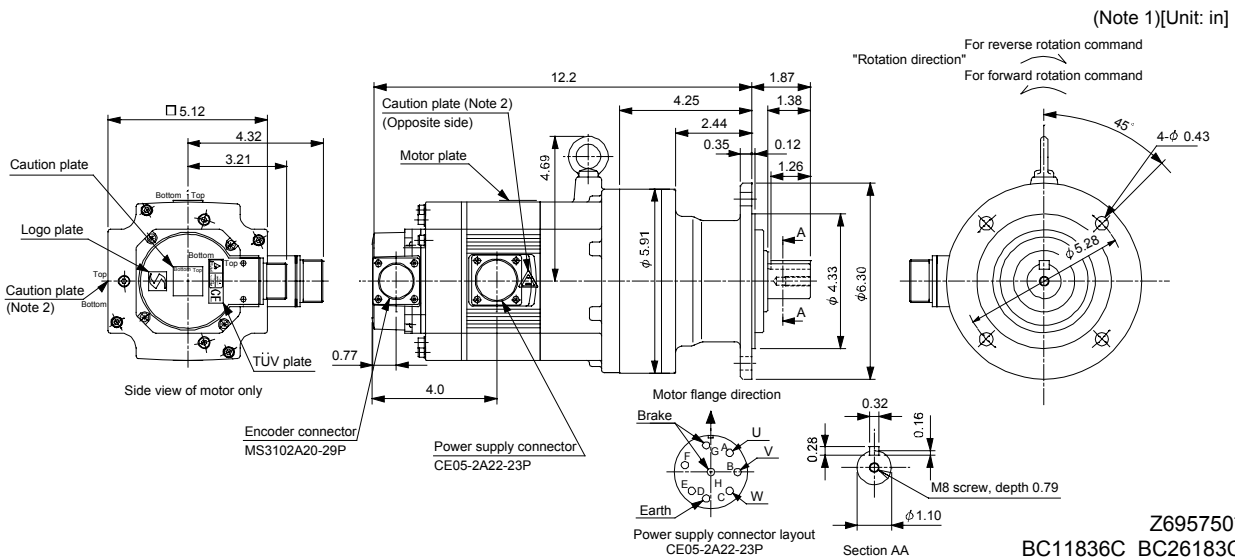

Note 1. The dimensions without tolerances are reference dimensions.
 2. This caution plate is attached to the 400V class motors only, not to the 200V class.

7. OUTLINE DIMENSION DRAWINGS

Model		Output [kW]	Reduction Ratio	Inertia Moment WK ² [oz · in ²]	Variable Dimensions [in]	Mass [lb]	Brake static friction torque [oz · in]
					L		
HC-SF102BG1	HC-SFS102BG1 HC-SFS1024BG1	1.0	1/59	115.77	17.01	187.4	1175
HC-SF152BG1	HC-SFS152BG1 HC-SFS1524BG1	1.5	1/43	150.36	17.99	191.8	1175
HC-SF152BG1	HC-SFS152BG1 HC-SFS1524BG1	1.5	1/59	149.95	17.99	191.8	1175

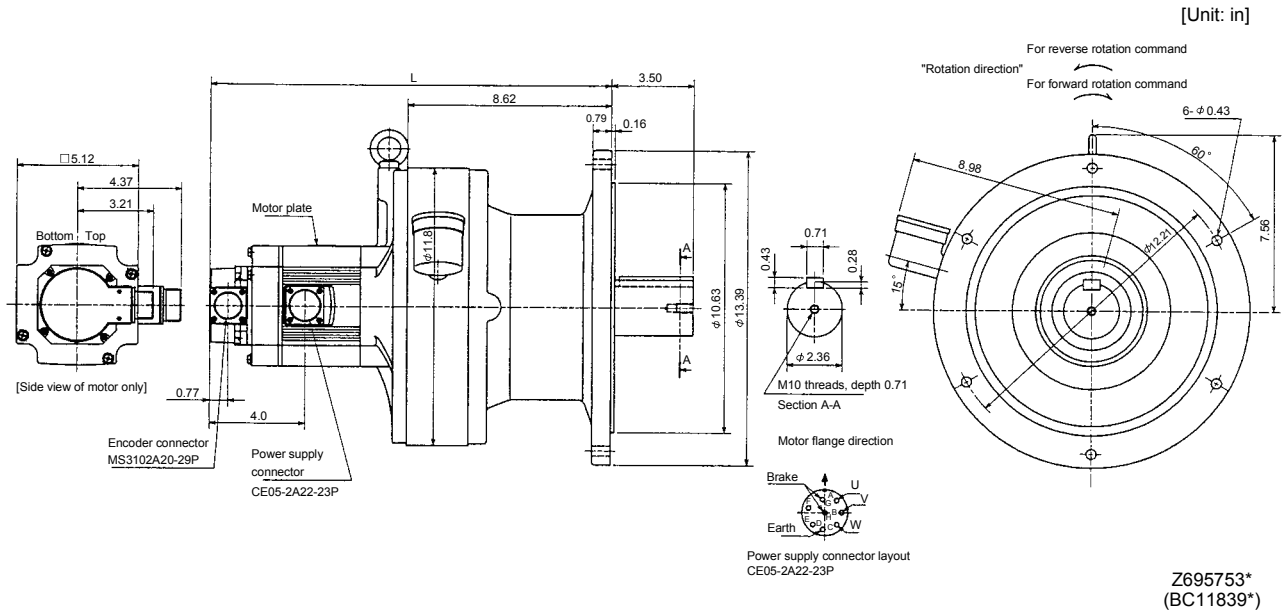

Model		Output [kW]	Reduction Ratio	Inertia Moment WK ² [oz · in ²]	Variable Dimensions [in]	Mass [lb]	Brake static friction torque [oz · in]
					L		
HC-SF102BG1	HC-SFS102BG1 HC-SFS1024BG1	1.0	1/43	94.86	14.69	110.2	1175
HC-SF152BG1	HC-SFS152BG1 HC-SFS1524BG1	1.5	1/29	129.99	15.67	114.6	1175
HC-SF152BG1	HC-SFS152BG1 HC-SFS1524BG1	1.5	1/35	129.72	15.67	114.6	1175

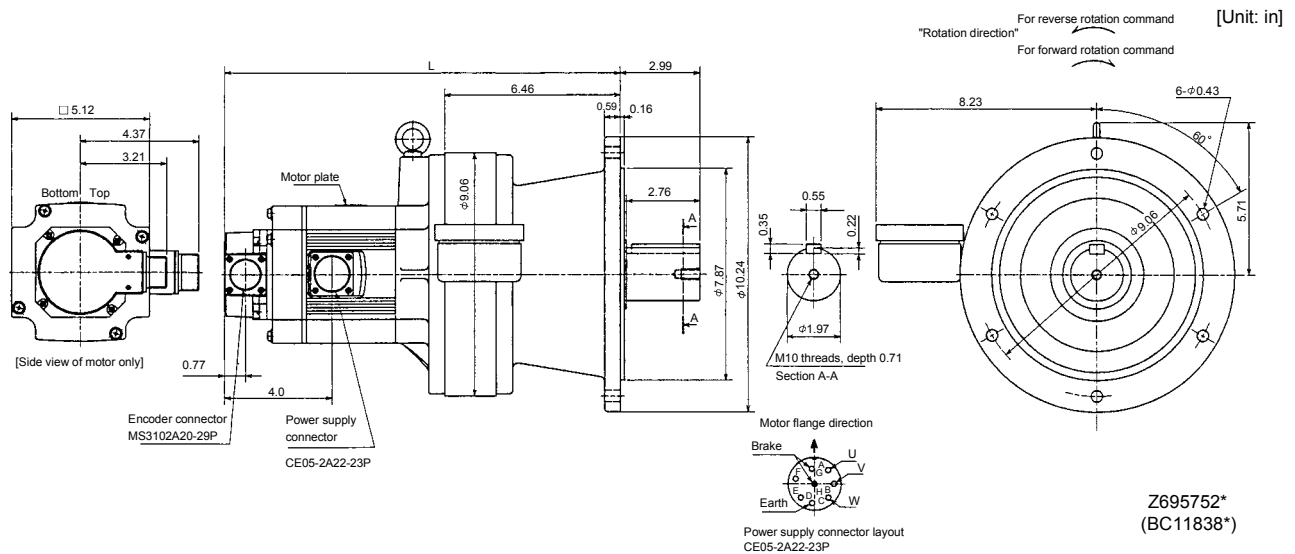

7. OUTLINE DIMENSION DRAWINGS

Model	Output [kW]	Reduction Ratio	Inertia Moment WK^2 [oz · in ²]	Mass [lb]	Brake static friction torque [oz · in]
HC-SF202BG1 HC-SFS202BG1 HC-SFS2024BG1	2.0	1/6	303.99	88.2	6103
HC-SF202BG1 HC-SFS202BG1 HC-SFS2024BG1	2.0	1/11	295.79	88.2	6103
HC-SF202BG1 HC-SFS202BG1 HC-SFS2024BG1	2.0	1/17	293.60	88.2	6103

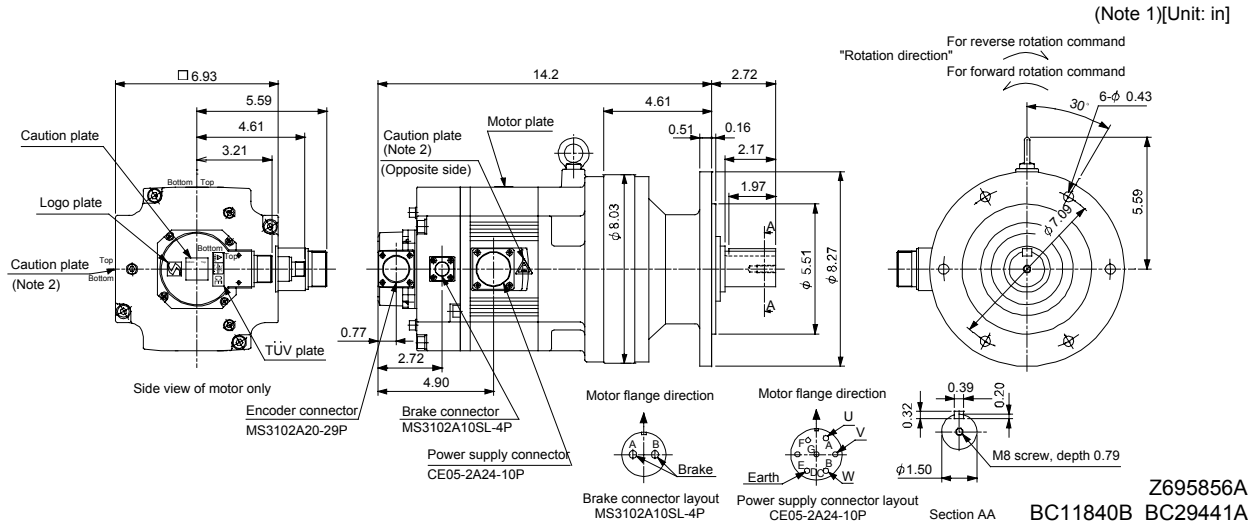

Note 1. The dimensions without tolerances are reference dimensions.
2. This caution plate is attached to the 400V class motors only, not to the 200V class.

Model	Output [kW]	Reduction Ratio	Inertia Moment WK^2 [oz · in ²]	Mass [lb]	Brake static friction torque [oz · in]
HC-SF352BG1 HC-SFS352BG1 HC-SFS3524BG1	3.5	1/6	547.29	138.9	6103
HC-SF352BG1 HC-SFS352BG1 HC-SFS3524BG1	3.5	1/11	525.97	138.9	6103
HC-SF352BG1 HC-SFS352BG1 HC-SFS3524BG1	3.5	1/17	519.41	138.9	6103

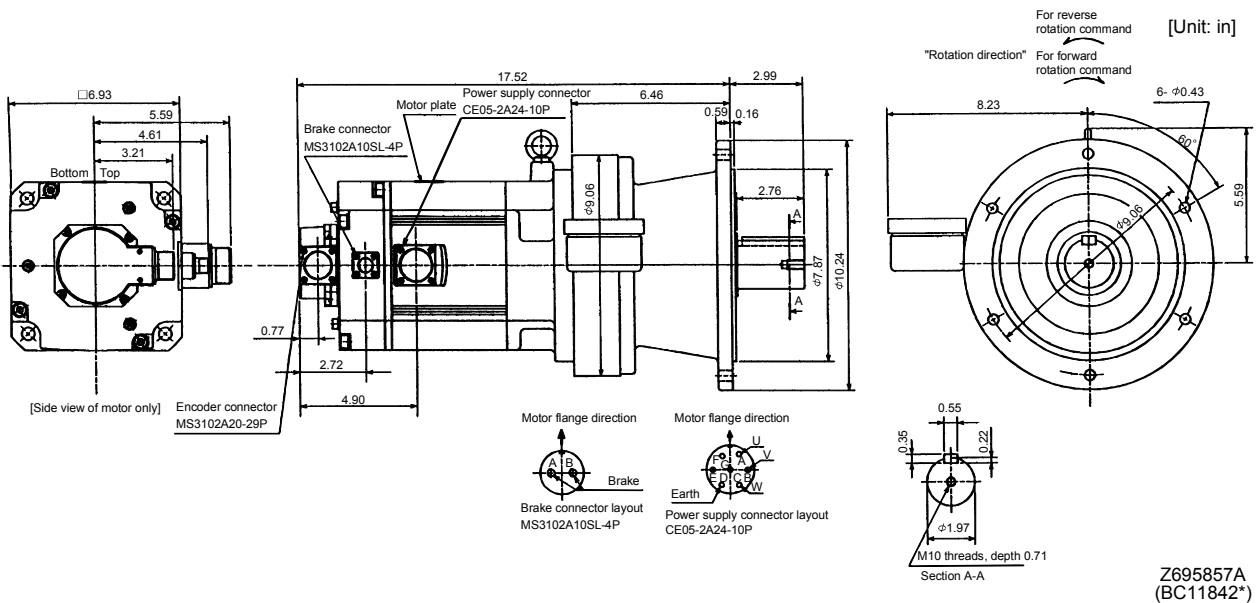

7. OUTLINE DIMENSION DRAWINGS

Model	Output [kW]	Reduction Ratio	Inertia Moment WK ² [oz · in ²]	Variable Dimensions [in]	Mass [lb]	Brake static friction torque [oz · in]
				L		
HC-SF202BG1 HC-SFS202BG1 HC-SFS2024BG1	2.0	1/29	322.03	17.99	198.4	6103
HC-SF202BG1 HC-SFS202BG1 HC-SFS2024BG1	2.0	1/35	320.39	17.99	198.4	6103
HC-SF202BG1 HC-SFS202BG1 HC-SFS2024BG1	2.0	1/43	319.30	17.99	198.4	6103
HC-SF202BG1 HC-SFS202BG1 HC-SFS2024BG1	2.0	1/59	318.75	17.99	198.4	6103
HC-SF352BG1 HC-SFS352BG1 HC-SFS3524BG1	3.5	1/29	538.0	19.65	213.8	6103
HC-SF352BG1 HC-SFS352BG1 HC-SFS3524BG1	3.5	1/35	536.36	19.65	213.8	6103

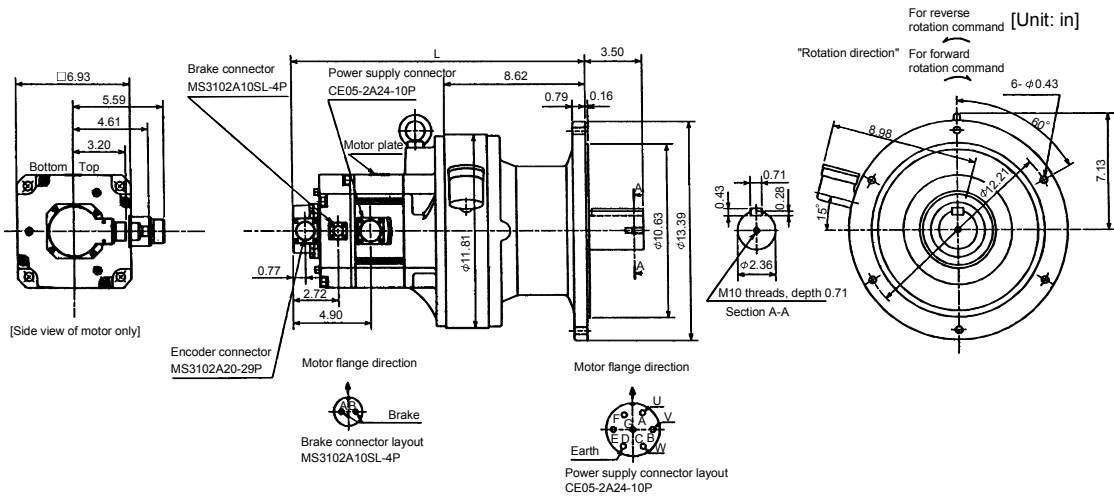

Z695858A
(BC11841*)

Model	Output [kW]	Reduction Ratio	Inertia Moment WK ² [oz · in ²]	Mass [lb]	Brake static friction torque [oz · in]
HC-SF352BG1 HC-SFS352BG1 HC-SFS3524BG1	3.5	1/43	636.96	306.4	6103
HC-SF352BG1 HC-SFS352BG1 HC-SFS3524BG1	3.5	1/59	633.68	306.4	6103

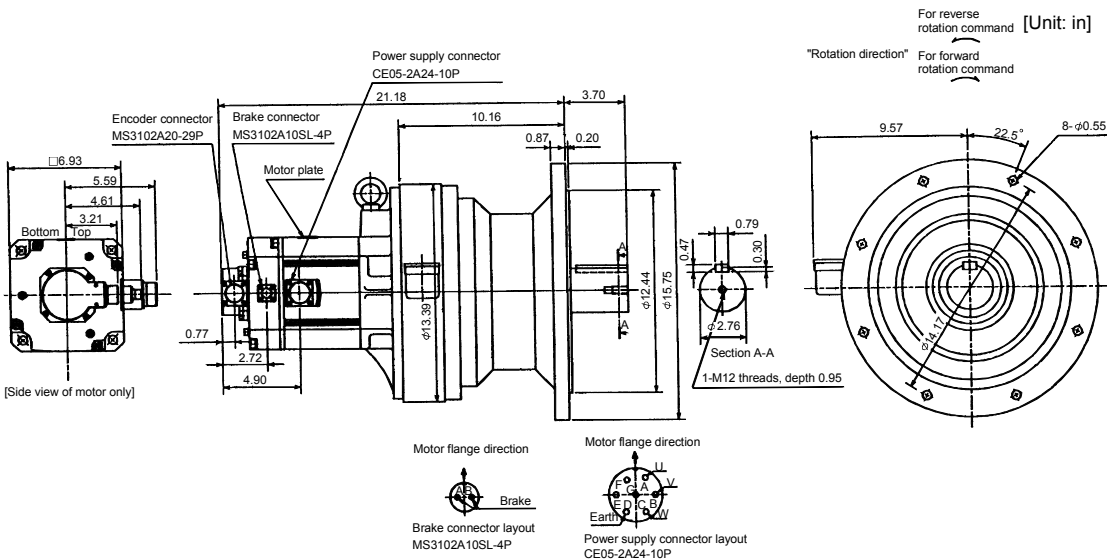

Z695859A
(BC11843*)

7. OUTLINE DIMENSION DRAWINGS

Model		Output [kW]	Reduction Ratio	Inertia Moment WK^2 [oz · in ²]	Mass [lb]	Brake static friction torque [oz · in]
HC-SF502BG1	HC-SFS502BG1 HC-SFS5024BG1	5.0	1/11	674.68	222.7	6103
HC-SF502BG1	HC-SFS502BG1 HC-SFS5024BG1	5.0	1/17	652.81	222.7	6103

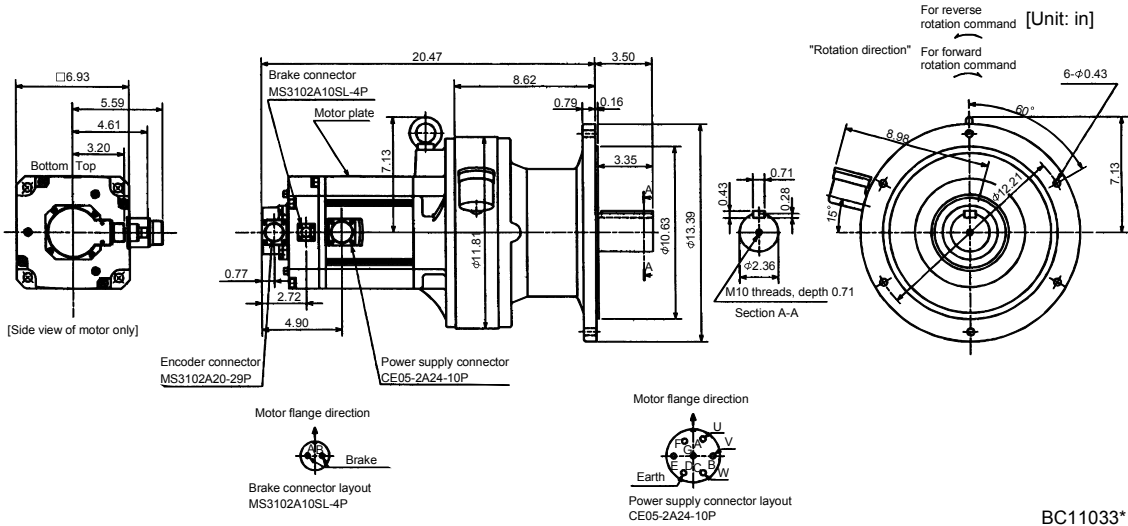

BC11033*
(BC11844*)

Model		Output [kW]	Reduction Ratio	Inertia Moment WK^2 [oz · in ²]	Mass [lb]	Brake static friction torque [oz · in]
HC-SF502BG1	HC-SFS502BG1 HC-SFS5024BG1	5.0	1/29	811.92	370.4	6103
HC-SF502BG1	HC-SFS502BG1 HC-SFS5024BG1	5.0	1/35	809.18	370.4	6103
HC-SF502BG1	HC-SFS502BG1 HC-SFS5024BG1	5.0	1/43	803.71	370.4	6103

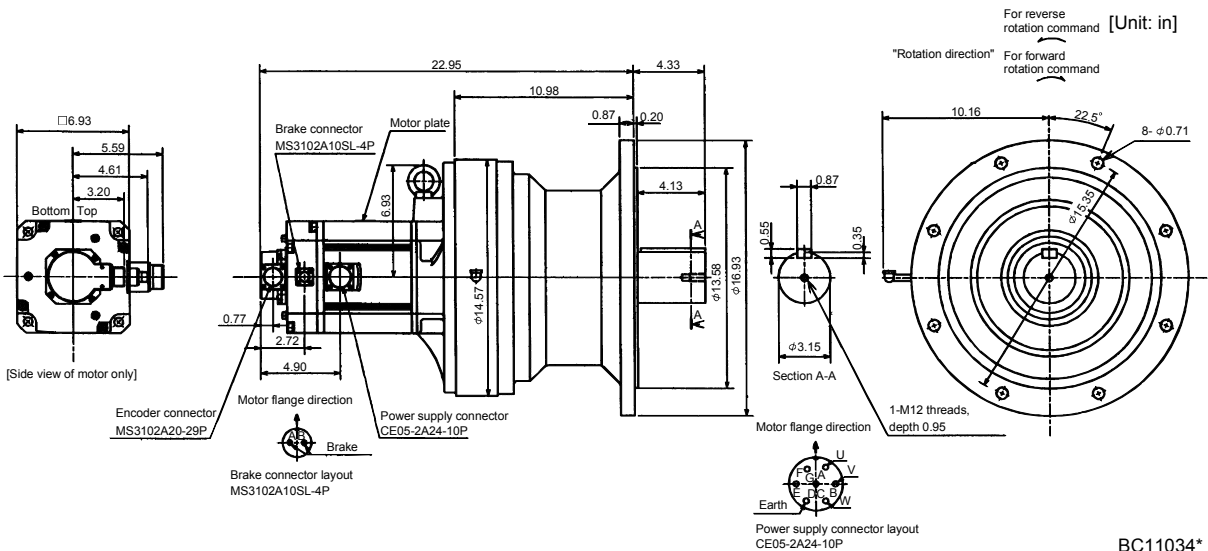

BC11034*
(BC11845*)

7. OUTLINE DIMENSION DRAWINGS

Model	Output [kW]	Reduction Ratio	Inertia Moment WK^2 [oz · in ²]	Mass [lb]	Brake static friction torque [oz · in]
HC-SF702BG1 HC-SFS7024BG1	7.0	1/11	1141.60	335.1	6103
HC-SF702BG1 HC-SFS7024BG1	7.0	1/17	1093.49	335.1	6103

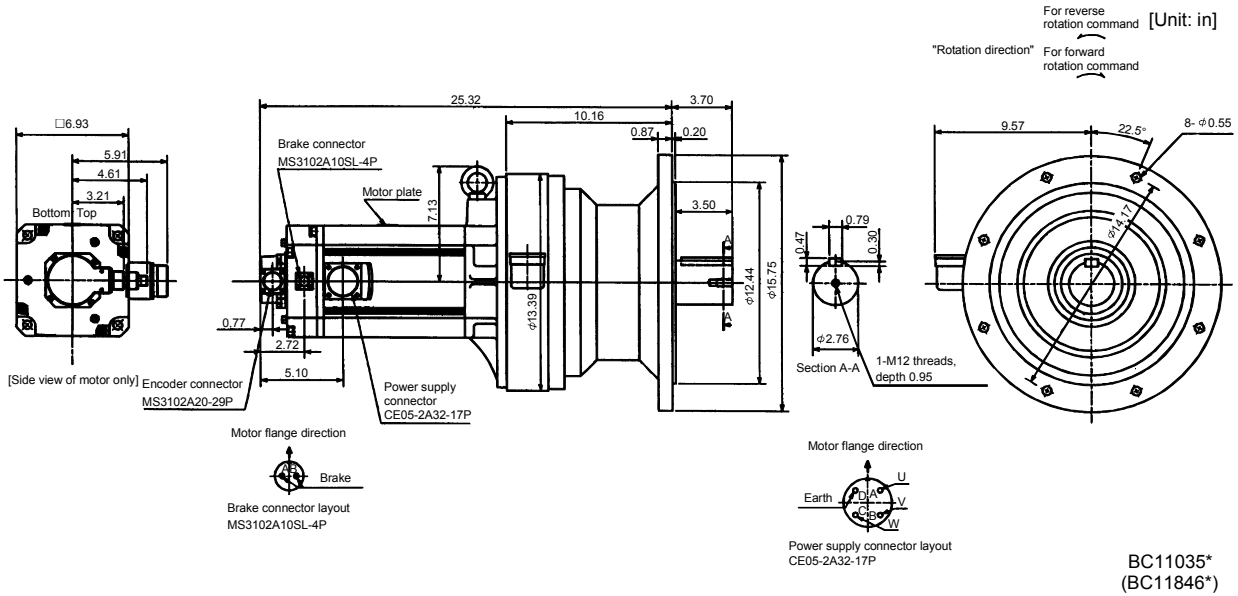

Model	Output [kW]	Reduction Ratio	Inertia Moment WK^2 [oz · in ²]	Mass [lb]	Brake static friction torque [oz · in]
HC-SF702BG1 HC-SFS7024BG1	7.0	1/29	1134.50	390.2	6103
HC-SF702BG1 HC-SFS7024BG1	7.0	1/35	1131.76	390.2	6103

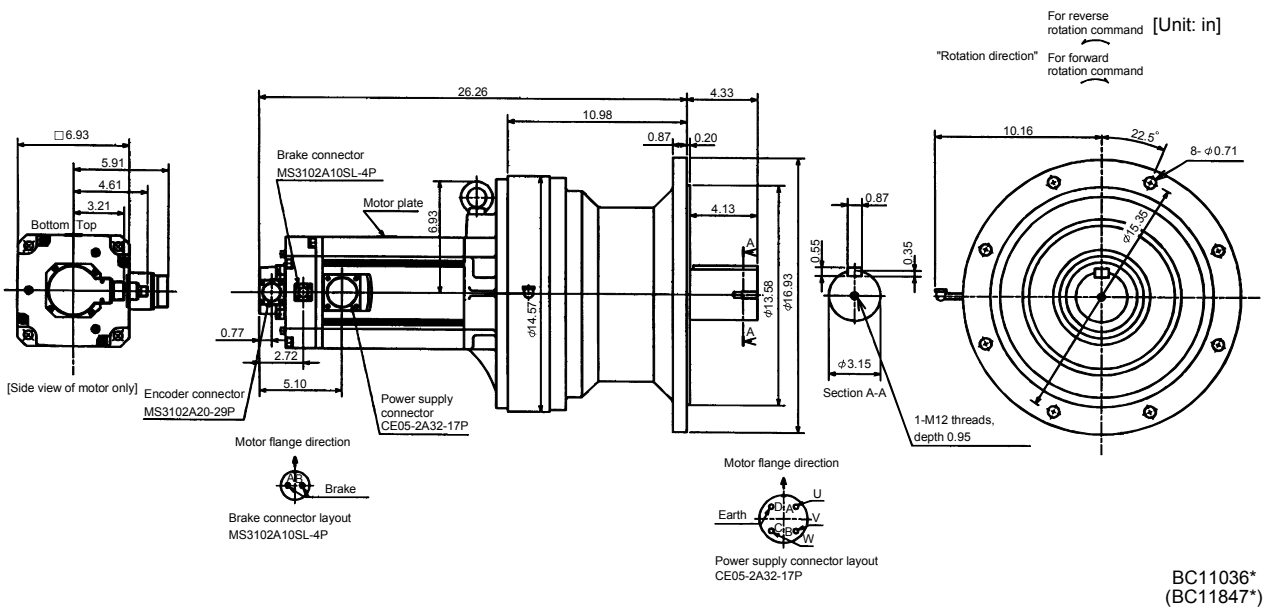

7. OUTLINE DIMENSION DRAWINGS

Model	Output [kW]	Reduction Ratio	Inertia Moment WK^2 [oz · in ²]	Mass [lb]	Brake static friction torque [oz · in]
HC-SF702BG1 HC-SFS702BG1 HC-SFS7024BG1	7.0	1/43	1458.71	542.3	6103

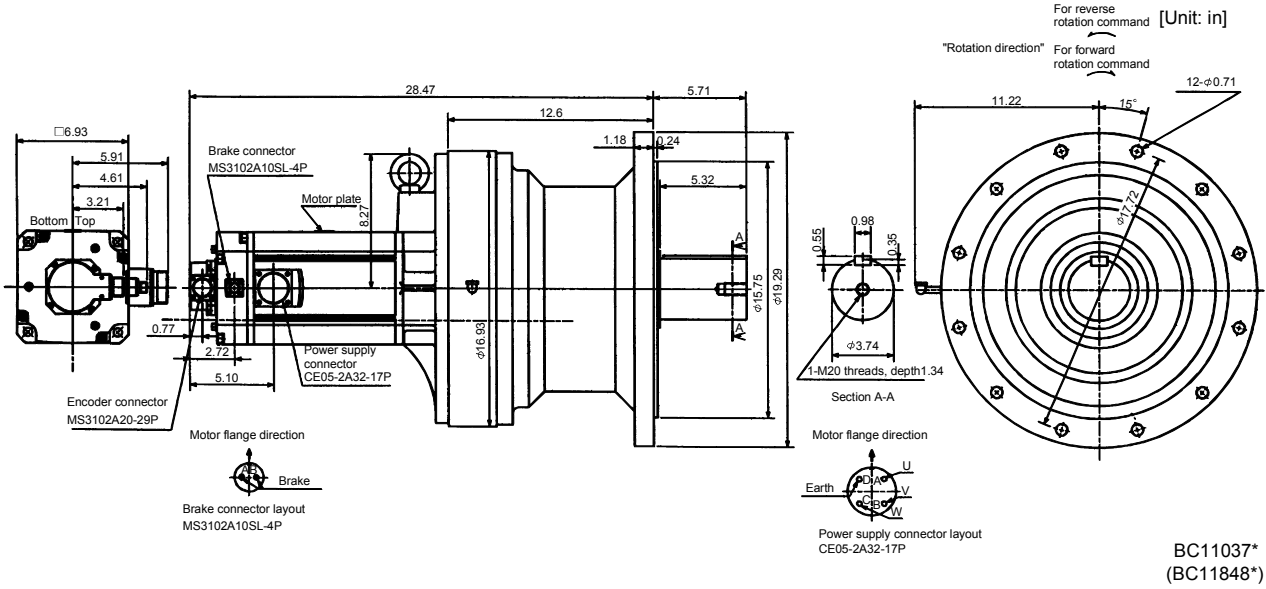

7. OUTLINE DIMENSION DRAWINGS

(5) With reduction gear for precision application

The outer frame of the reduction gear is a material surface such as casting. Its actual dimensions may be 0.039 to 0.118 in larger than the drawing dimensions. Design the machine side with allowances.

(a) Without electromagnetic brake

Model			Output [kW]	Reduction Gear Model	Reduction Ratio	Inertia Moment WK^2 [oz · in ²]	Variable Dimensions [in]		Mass [lb]
L	H								
HC-SF52G2	HC-SFS52G2	HC-SFS524G2	0.5	BL2-05B-05MEH	1/5	43.19	10.87	6.14	28.7
HC-SF52G2	HC-SFS52G2	HC-SFS524G2	0.5	BL2-09B-05MEH	1/9	41.28	11.34	6.61	28.7
HC-SF52G2	HC-SFS52G2	HC-SFS524G2	0.5	BL2-20B-05MEH	1/20	43.88	12.17	7.44	33.1
HC-SF102G2	HC-SFS102G2	HC-SFS1024G2	1.0	BL2-05B-10MEH	1/5	81.88	11.85	6.14	33.1
HC-SF102G2	HC-SFS102G2	HC-SFS1024G2	1.0	BL2-09B-10MEH	1/9	79.96	12.32	6.61	33.1
HC-SF152G2	HC-SFS152G2	HC-SFS1524G2	1.5	BL2-05B-15MEH	1/5	116.05	12.84	6.14	37.5

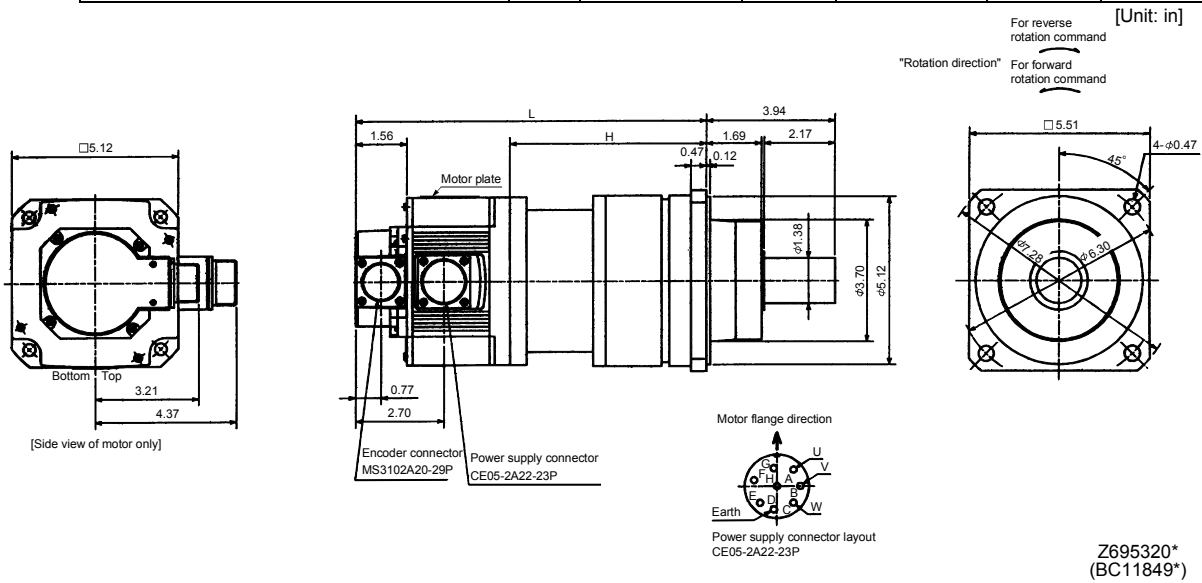

Model			Output [kW]	Reduction Gear Model	Reduction Ratio	Inertia Moment WK^2 [oz · in ²]	Variable Dimensions [in]		Mass [lb]
L	H								
HC-SF52G2	HC-SFS52G2	HC-SFS524G2	0.5	BL3-29B-05MEH	1/29	51.39	13.27	8.54	66.1
HC-SF52G2	HC-SFS52G2	HC-SFS524G2	0.5	BL3-45B-05MEH	1/45	46.06	13.50	8.78	66.1
HC-SF102G2	HC-SFS102G2	HC-SFS1024G2	1.0	BL3-20B-10MEH	1/20	100.46	14.25	8.54	70.5
HC-SF102G2	HC-SFS102G2	HC-SFS1024G2	1.0	BL3-29B-10MEH	1/29	90.08	14.25	8.54	70.5
HC-SF152G2	HC-SFS152G2	HC-SFS1524G2	1.5	BL3-09B-15MEH	1/9	134.77	14.92	8.23	75.0
HC-SF152G2	HC-SFS152G2	HC-SFS1524G2	1.5	BL3-20B-15MEH	1/20	134.64	15.24	8.54	75.0

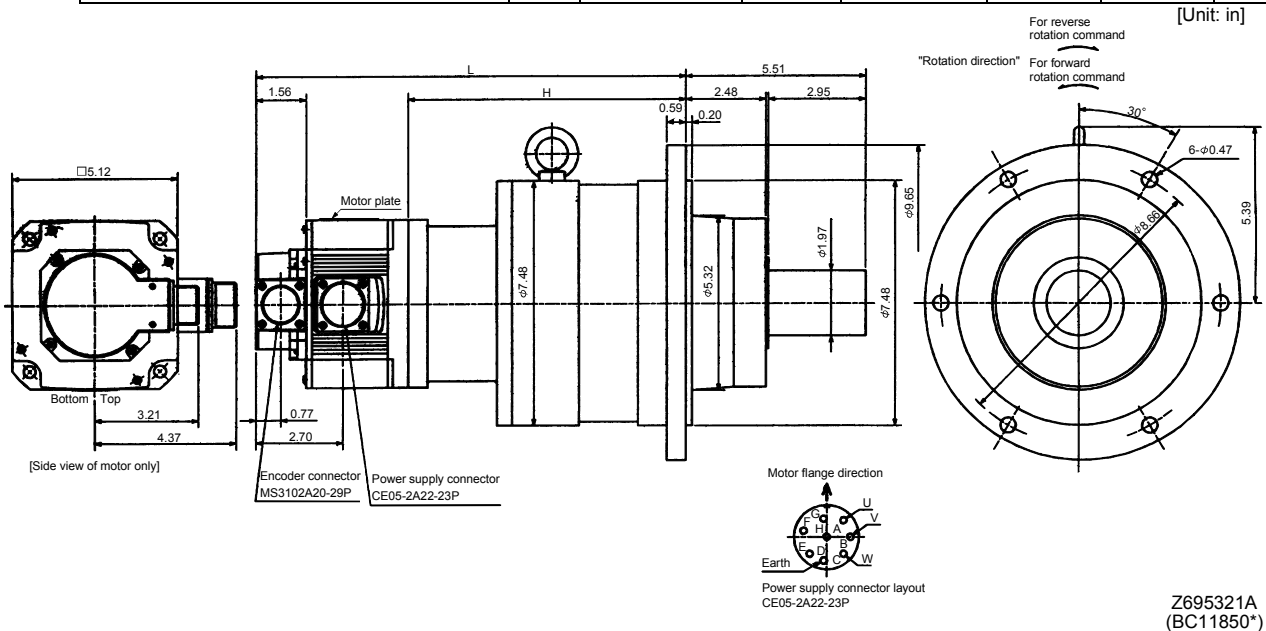

7. OUTLINE DIMENSION DRAWINGS

Model	Output [kW]	Reduction Gear Model	Reduction Ratio	Inertia Moment WK ² [oz · in ²]	Variable Dimensions [in]		Mass [lb]
					L	H	
HC-SF102G2 HC-SFS102G2 HC-SFS1024G2	1.0	BL4-45B-10MEH	1/45	110.85	15.32	9.61	114.6
HC-SF152G2 HC-SFS152G2 HC-SFS1524G2	1.5	BL4-29B-15MEH	1/29	165.53	16.18	9.49	119.0
HC-SF152G2 HC-SFS152G2 HC-SFS1524G2	1.5	BL4-45B-15MEH	1/45	145.02	16.30	9.61	119.0

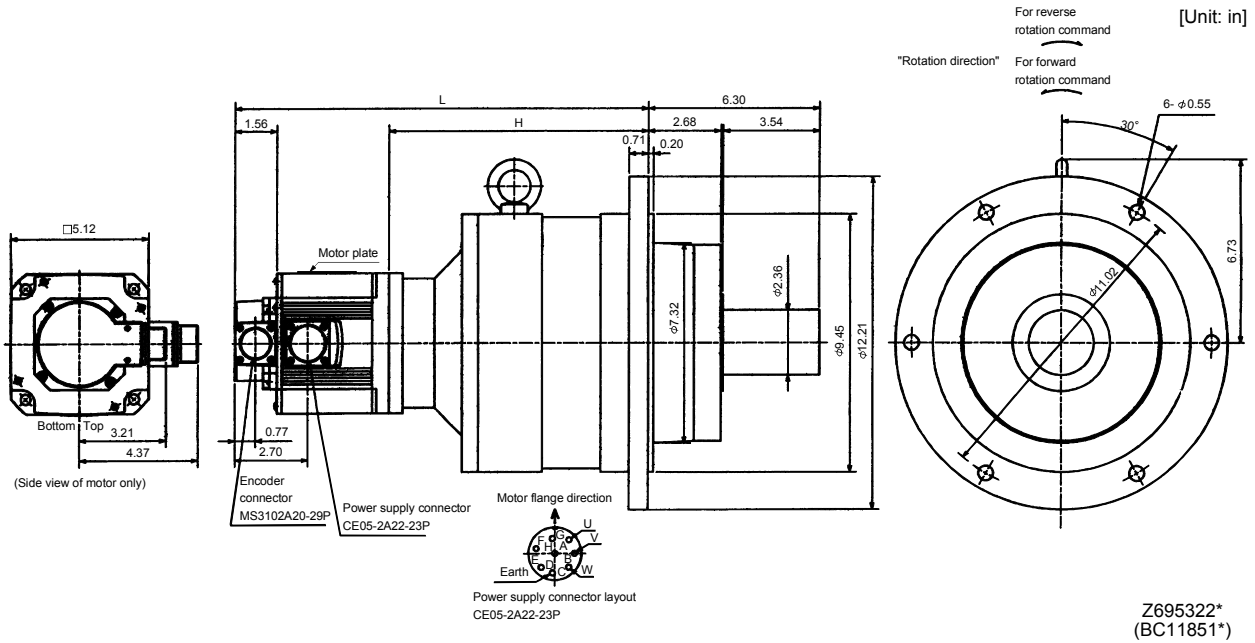

Model	Output [kW]	Reduction Gear Model	Reduction Ratio	Inertia Moment WK ² [oz · in ²]	Variable Dimensions [in]		Mass [lb]
					L	H	
HC-SF202G2 HC-SFS202G2 HC-SFS2024G2	2.0	BL3-05B-20MEH	1/5	271.19	13.70	7.99	66.1
HC-SF202G2 HC-SFS202G2 HC-SFS2024G2	2.0	BL3-09B-20MEH	1/9	258.06	14.76	9.06	81.6

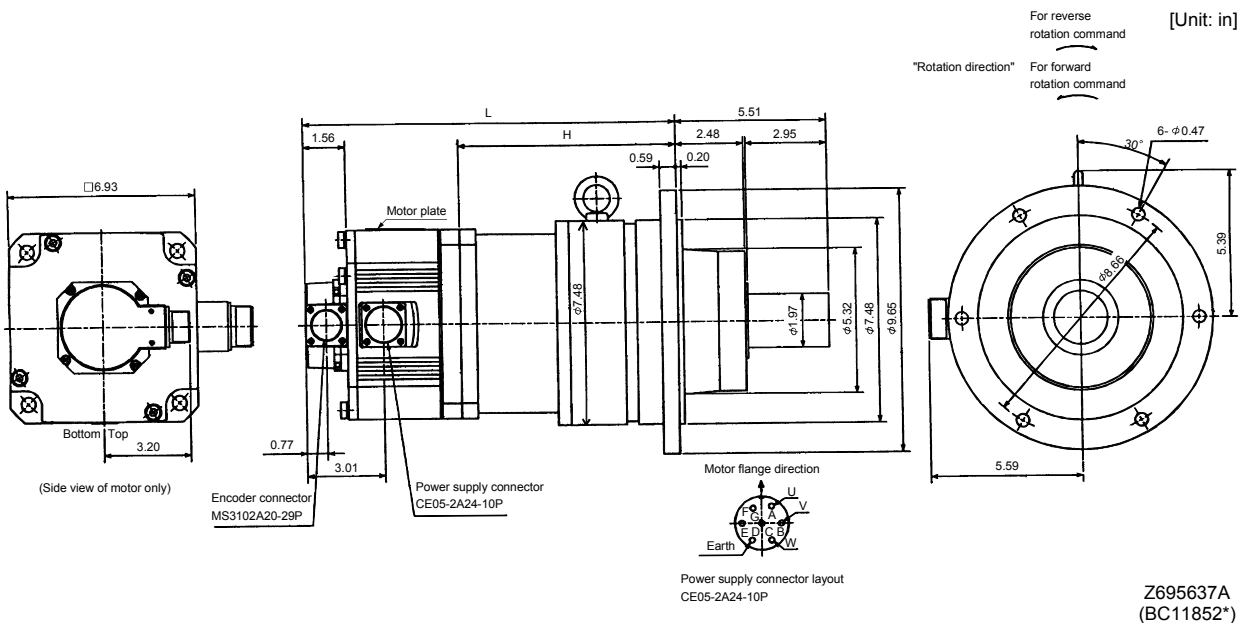

7. OUTLINE DIMENSION DRAWINGS

Model	Output [kW]	Reduction Gear Model	Reduction Ratio	Variable Dimensions [in]		Inertia Moment WK ² [oz · in ²]	Mass [lb]
				L	H		
HC-SF202G2 HC-SFS202G2 HC-SFS2024G2	2.0	BL4-20B-20MEH	1/20	10.32	326.0	16.02	125.7
HC-SF202G2 HC-SFS202G2 HC-SFS2024G2	2.0	BL4-29B-20MEH	1/29	10.32	288.82	16.02	125.7
HC-SF202G2 HC-SFS202G2 HC-SFS2024G2	2.0	BL4-45B-20MEH	1/45	10.43	268.32	16.14	125.7
HC-SF352G2 HC-SFS352G2 HC-SFS3524G2	3.5	BL4-05B-35MEH	1/5	8.78	543.33	16.14	119.0
HC-SF352G2 HC-SFS352G2 HC-SFS3524G2	3.5	BL4-09B-35MEH	1/9	10.04	500.14	17.40	141.1
HC-SF352G2 HC-SFS352G2 HC-SFS3524G2	3.5	BL4-20B-35MEH	1/20	10.32	541.96	17.68	141.1

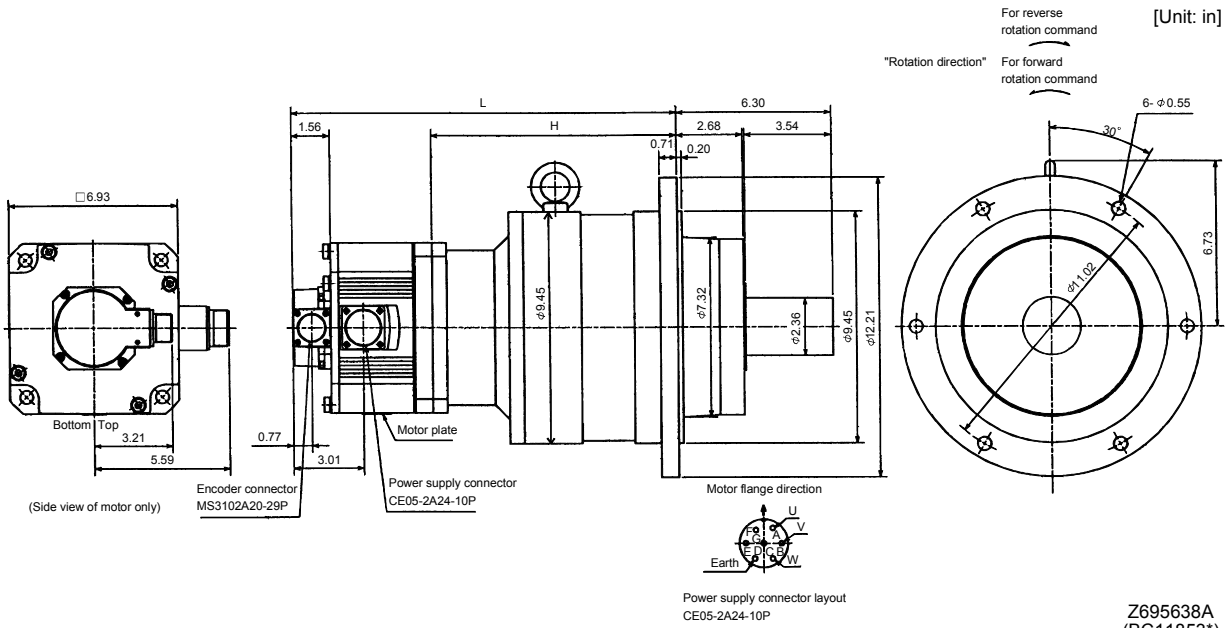

Z695638A
(BC11853*)

Model	Output [kW]	Reduction Gear Model	Reduction Ratio	Variable Dimensions [in]		Inertia Moment WK ² [oz · in ²]	Mass [lb]
				L	H		
HC-SF502G2 HC-SFS502G2 HC-SFS5024G2	5.0	BL4-05B-50MEH	1/5	16.97	10.04	647.35	127.9
HC-SF502G2 HC-SFS502G2 HC-SFS5024G2	5.0	BL4-09B-50MEH	1/9	18.23	8.78	604.15	149.9

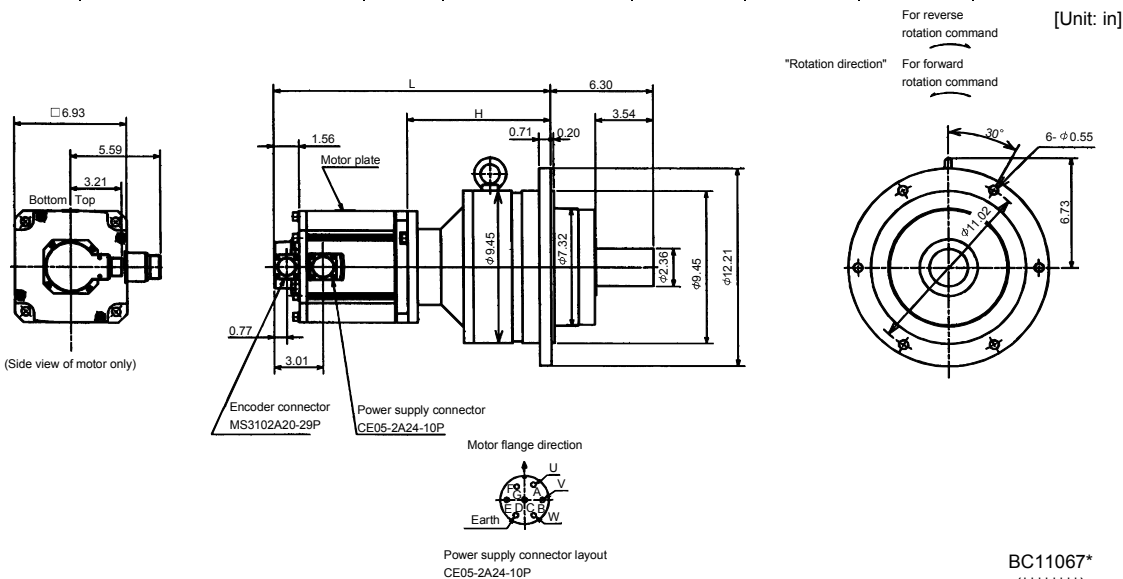

BC11067*
(*****)

7. OUTLINE DIMENSION DRAWINGS

Model	Output [kW]	Reduction Gear Model	Reduction Ratio	Inertia Moment WK^2 [oz · in ²]	Mass [lb]
HC-SF702G2 HC-SFS702G2 HC-SFS7024G2	7.0	BL4-05B-70MEH	1/5	969.93	147.7

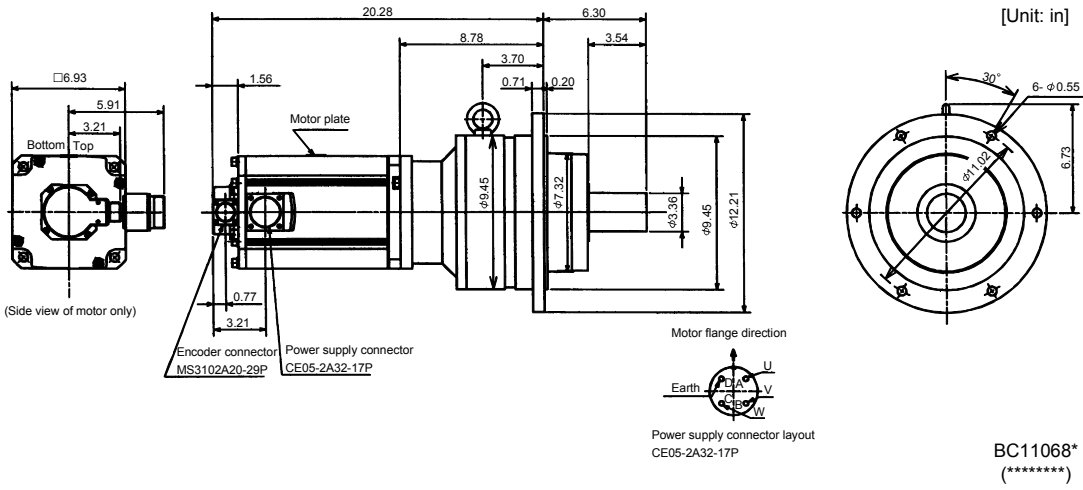

(b) With electromagnetic brake

Model	Output [kW]	Reduction Gear Model	Reduction Ratio	Inertia Moment WK^2 [oz · in ²]	Variable Dimensions [in]		Brake static friction torque [oz · in]	Mass [lb]
					L	H		
HC-SF52BG2 HC-SFS52BG2 HC-SFS524BG2	0.5	BL2-05B-05MEH	1/5	52.49	12.17	6.14	1204	33.1
HC-SF52BG2 HC-SFS52BG2 HC-SFS524BG2	0.5	BL2-09B-05MEH	1/9	50.57	12.64	6.61	1204	33.1
HC-SF52BG2 HC-SFS52BG2 HC-SFS524BG2	0.5	BL2-20B-05MEH	1/20	53.17	13.47	7.44	1204	37.5
HC-SF102BG2 HC-SFS102BG2 HC-SFS1024BG2	1.0	BL2-05B-10MEH	1/5	91.17	13.15	6.14	1204	37.5
HC-SF102BG2 HC-SFS102BG2 HC-SFS1024BG2	1.0	BL2-09B-10MEH	1/9	89.26	13.62	6.61	1204	37.5
HC-SF152BG2 HC-SFS152BG2 HC-SFS1524BG2	1.5	BL2-05B-15MEH	1/5	125.34	14.13	6.14	1204	41.9

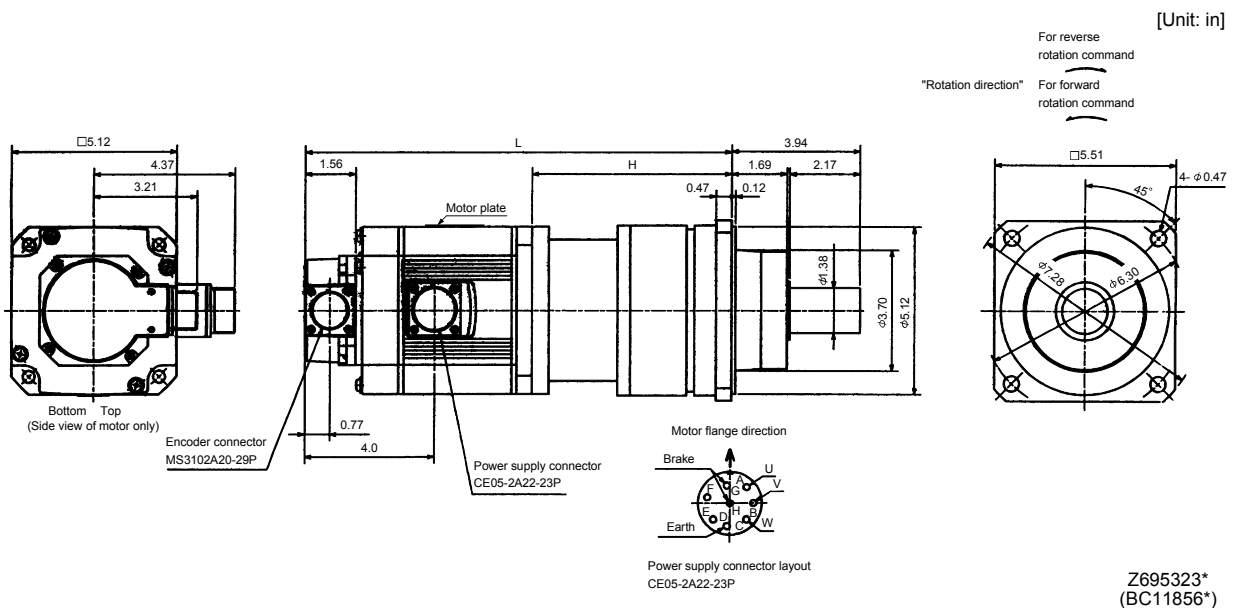

7. OUTLINE DIMENSION DRAWINGS

Model			Output [kW]	Reduction Gear Model	Reduction Ratio	Inertia Moment WK ² [oz · in ²]	Variable Dimensions [in]		Brake static friction torque [oz · in]	Mass [lb]
							L	H		
HC-SF52BG2	HC-SFS52BG2	HC-SFS524BG2	0.5	BL3-29B-05MEH	1/29	60.69	14.57	8.54	1204	70.5
HC-SF52BG2	HC-SFS52BG2	HC-SFS524BG2	0.5	BL3-45B-05MEH	1/45	55.36	14.80	8.78	1204	70.5
HC-SF102BG2	HC-SFS102BG2	HC-SFS1024BG2	1.0	BL3-20B-10MEH	1/20	109.76	15.55	8.54	1204	75.0
HC-SF102BG2	HC-SFS102BG2	HC-SFS1024BG2	1.0	BL3-29B-10MEH	1/29	99.37	15.55	8.54	1204	75.0
HC-SF152BG2	HC-SFS152BG2	HC-SFS1524BG2	1.5	BL3-09B-15MEH	1/9	144.07	16.22	8.23	1204	79.4
HC-SF152BG2	HC-SFS152BG2	HC-SFS1524BG2	1.5	BL3-20B-15MEH	1/20	143.93	16.54	8.54	1204	79.4

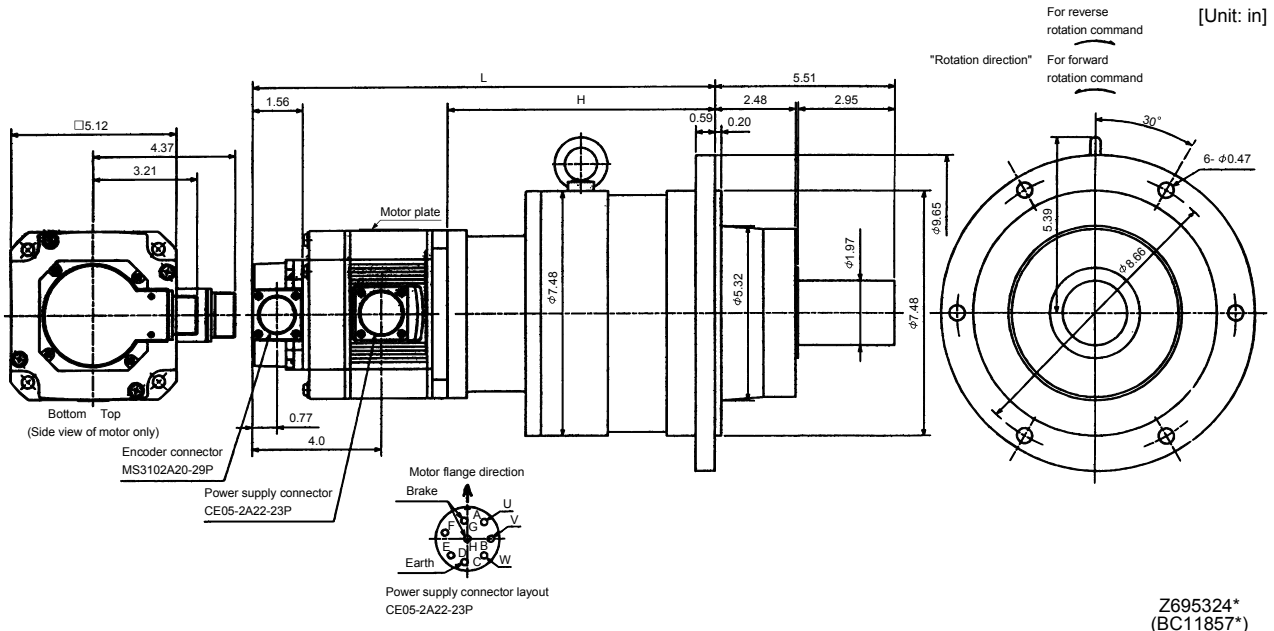

Model			Output [kW]	Reduction Gear Model	Reduction Ratio	Inertia Moment WK ² [oz · in ²]	Variable Dimensions [in]		Brake static friction torque [oz · in]	Mass [lb]
							L	H		
HC-SF102BG2	HC-SFS102BG2	HC-SFS1024BG2	1.0	BL4-45B-10MEH	1/45	120.15	16.61	9.61	1204	114.6
HC-SF152BG2	HC-SFS152BG2	HC-SFS1524BG2	1.5	BL4-29B-15MEH	1/29	174.82	17.48	9.49	1204	123.5
HC-SF152BG2	HC-SFS152BG2	HC-SFS1524BG2	1.5	BL4-45B-15MEH	1/45	154.32	17.60	9.61	1204	123.5

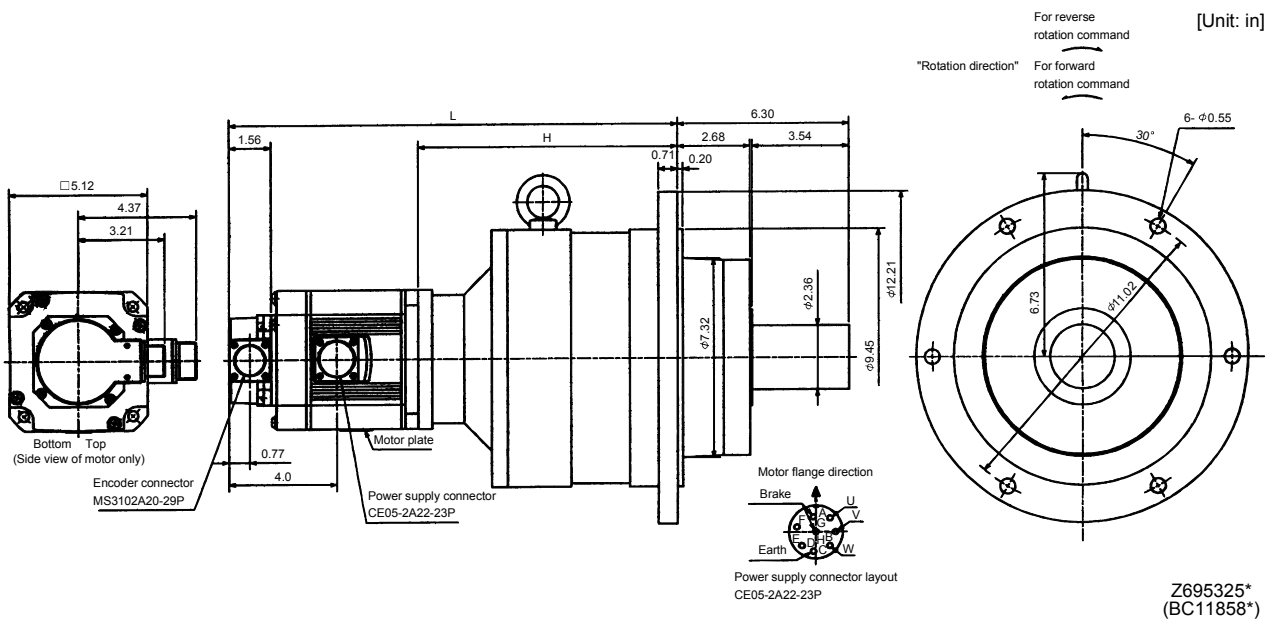

7. OUTLINE DIMENSION DRAWINGS

Model	Output [kW]	Reduction Gear Model	Reduction Ratio	Variable Dimensions [in]		Brake static friction torque [oz · in]	Inertia Moment WK ² [oz · in ²]	Mass [lb]
				L	H			
HC-SF202BG2 HC-SFS202BG2 HC-SFS2024BG2	2.0	BL3-05B-20MEH	1/5	15.59	7.99	6103	325.86	79.4
HC-SF202BG2 HC-SFS202BG2 HC-SFS2024BG2	2.0	BL3-09B-20MEH	1/9	16.65	9.06	6103	312.74	94.8

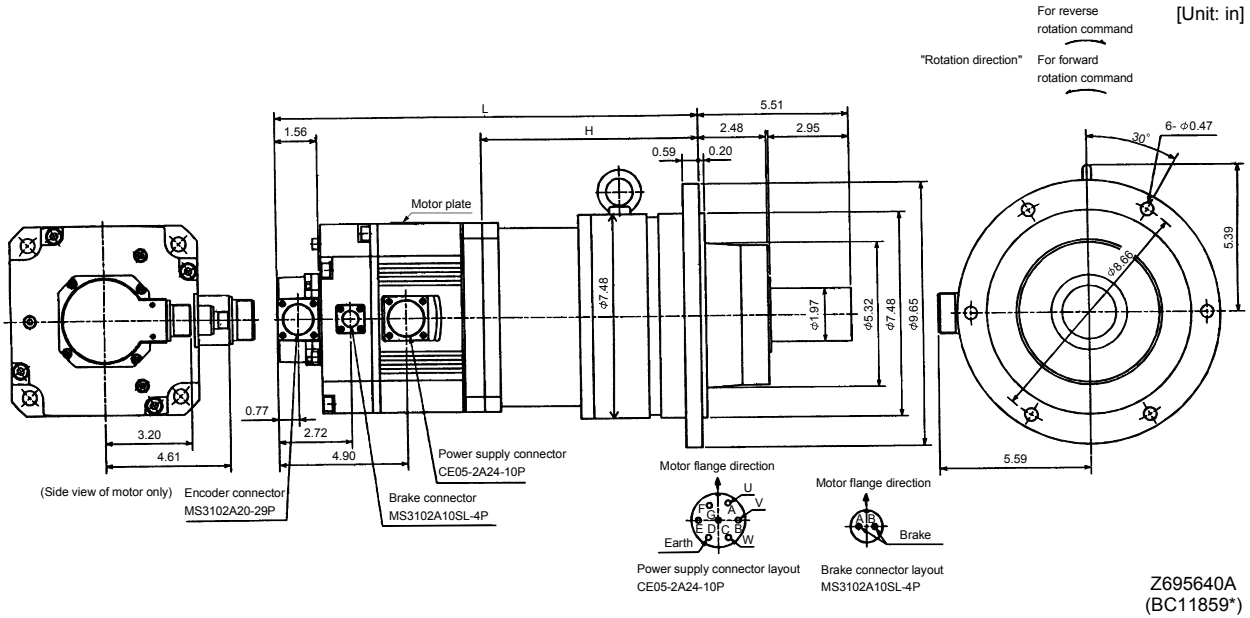

Model	Output [kW]	Reduction Gear Model	Reduction Ratio	Variable Dimensions [in]		Brake static friction torque [oz · in]	Inertia Moment WK ² [oz · in ²]	Mass [lb]
				L	H			
HC-SF202BG2 HC-SFS202BG2 HC-SFS2024BG2	2.0	BL4-20B-20MEH	1/20	17.91	10.32	6103	380.67	138.9
HC-SF202BG2 HC-SFS202BG2 HC-SFS2024BG2	2.0	BL4-29B-20MEH	1/29	17.91	10.32	6103	343.49	138.9
HC-SF202BG2 HC-SFS202BG2 HC-SFS2024BG2	2.0	BL4-45B-20MEH	1/45	18.03	10.43	6103	322.99	138.9
HC-SF352BG2 HC-SFS352BG2 HC-SFS3524BG2	3.5	BL4-05B-35MEH	1/5	18.03	8.78	6103	598.0	132.3
HC-SF352BG2 HC-SFS352BG2 HC-SFS3524BG2	3.5	BL4-09B-35MEH	1/9	19.29	10.04	6103	554.81	154.3
HC-SF352BG2 HC-SFS352BG2 HC-SFS3524BG2	3.5	BL4-20B-35MEH	1/20	19.57	10.32	6103	596.64	154.3

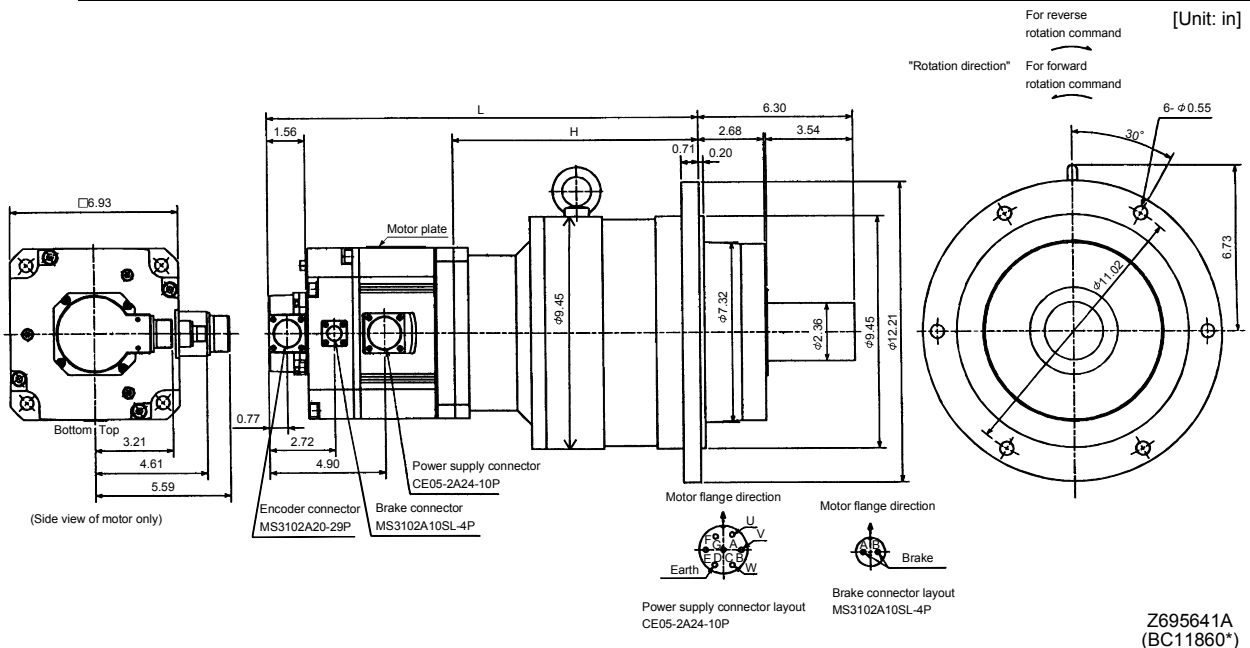

7. OUTLINE DIMENSION DRAWINGS

Model	Output [kW]	Reduction Gear Model	Reduction Ratio	Variable Dimensions [in]		Inertia Moment WK ² [oz · in ²]	Mass [lb]	Brake static friction torque [oz · in]
				L	H			
HC-SF502BG2 HC-SFS502BG2 HC-SFS5024BG2	5.0	BL4-05B-50MEH	1/5	18.86	8.78	702.02	141.1	6103
HC-SF502BG2 HC-SFS502BG2 HC-SFS5024BG2	5.0	BL4-09B-50MEH	1/9	20.12	10.04	658.83	163.1	6103

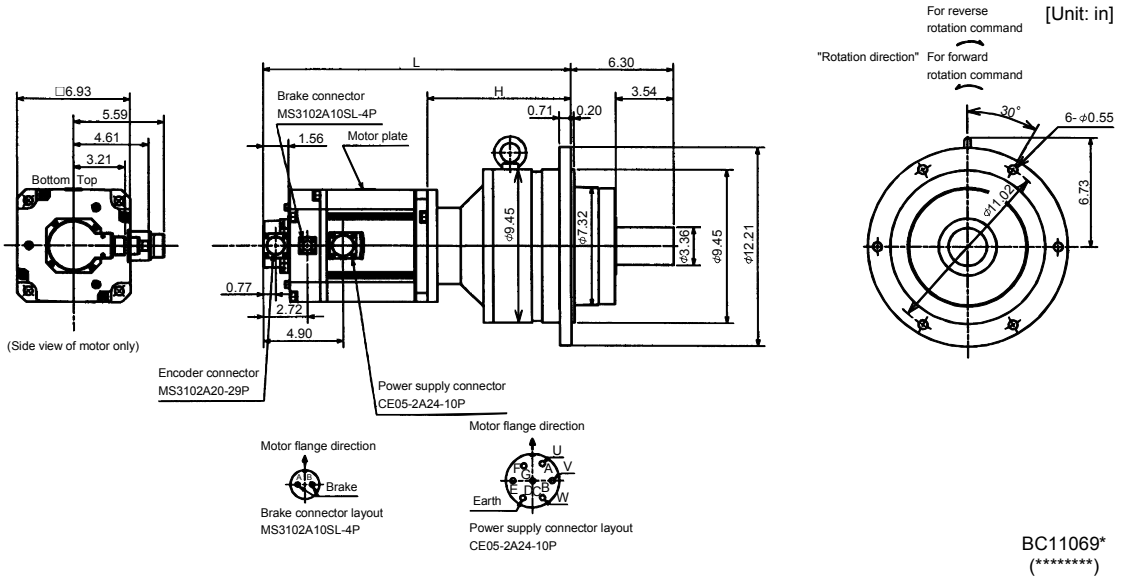

Model	Output [kW]	Reduction Gear Model	Reduction Ratio	Inertia Moment WK ² [oz · in ²]	Mass [lb]	Brake static friction torque [oz · in]
HC-SF702BG2 HC-SFS702BG2 HC-SFS7024BG2	7.0	BL4-05B-70MEH	1/5	1024.60	160.9	6103

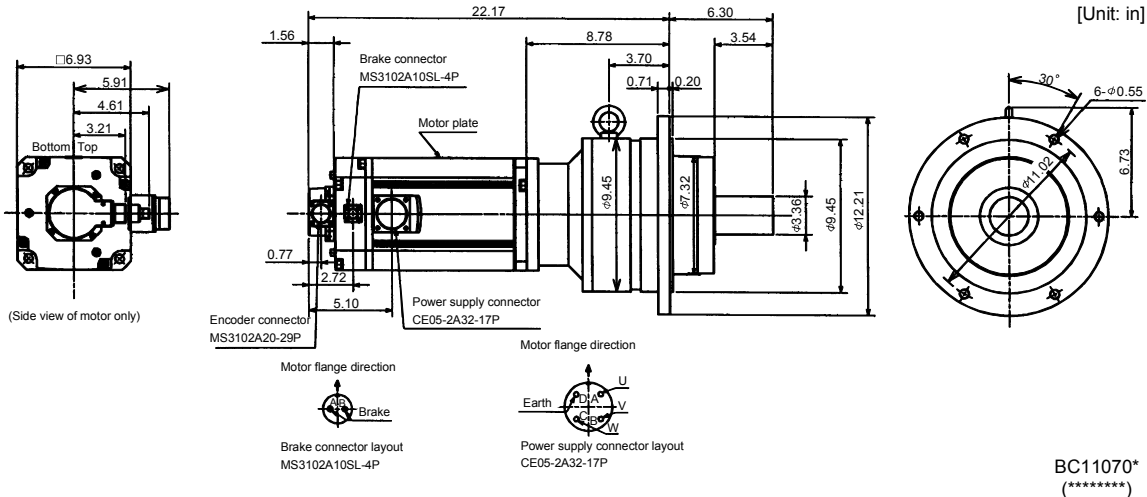

7. OUTLINE DIMENSION DRAWINGS

7.2.4 HC-RF • HC-RFS series

(1) Standard (without electromagnetic brake, without reduction gear)

Model		Output [kW]	Inertia Moment WK ² [oz • in ²]	Variable Dimensions [in]		Mass [lb]
				L	KL	
HC-RF103	HC-RFS103	1.0	8.20	5.79	2.80	8.6
HC-RF153	HC-RFS153	1.5	10.39	6.77	3.78	11.0
HC-RF203	HC-RFS203	2.0	12.58	7.76	4.76	13.7

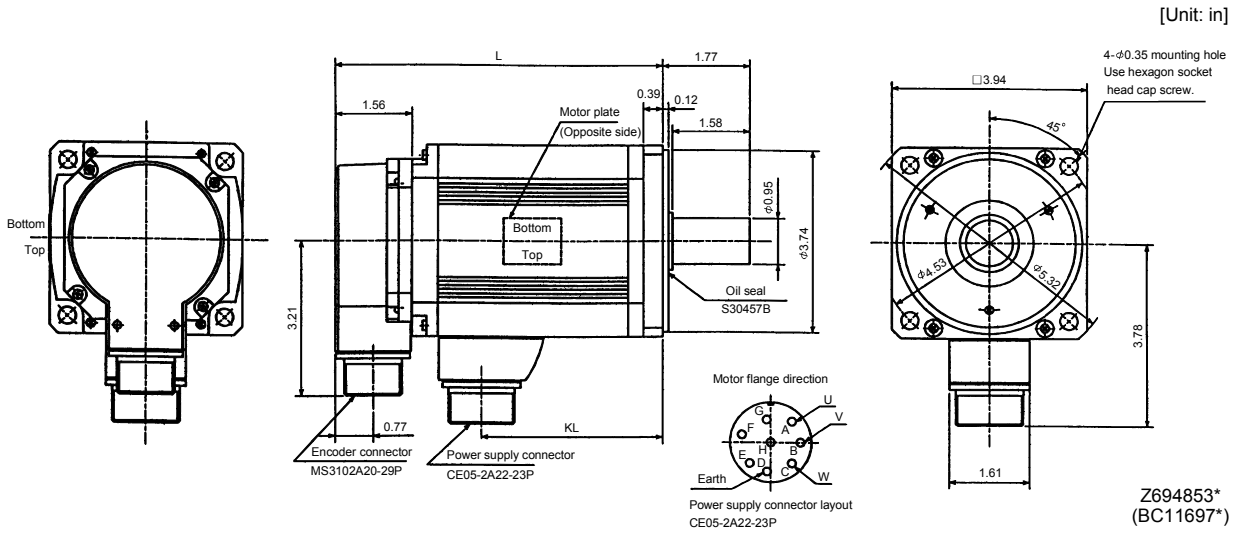

Model		Output [kW]	Variable Dimensions [in]		Inertia Moment WK ² [oz • in ²]	Mass [lb]
			L	KL		
HC-RF353	HC-RFS353	3.5	8.543	5.827	47.02	26.5
HC-RF503	HC-RFS503	5.0	10.787	8.071	65.609	37.5

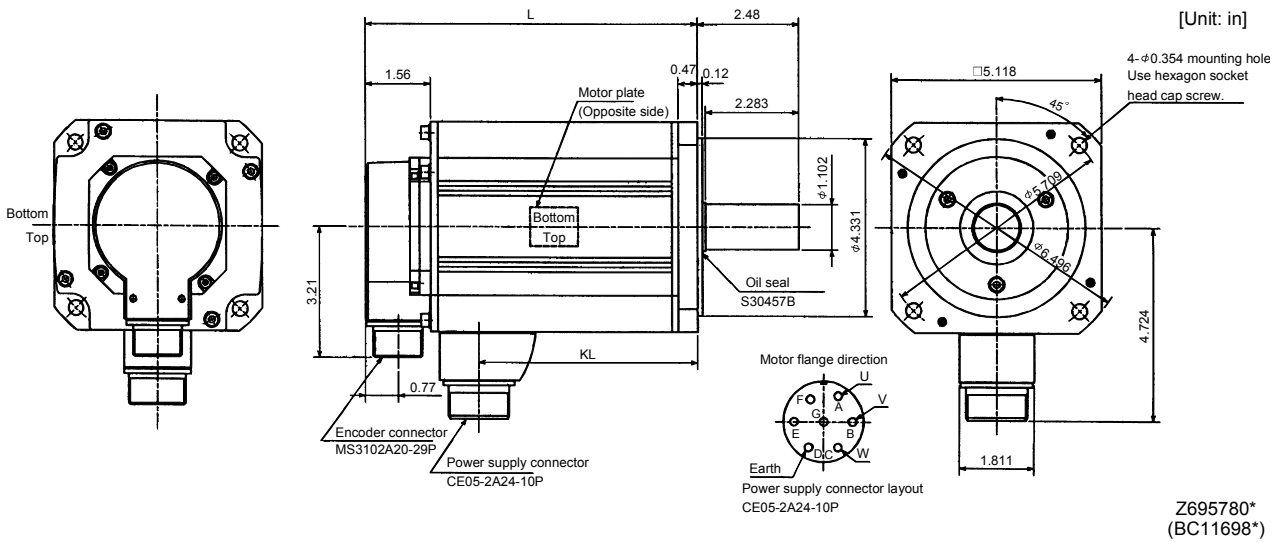

7. OUTLINE DIMENSION DRAWINGS

(2) With electromagnetic brake

Model	Output [kW]	Inertia Moment WK^2 [oz · in ²]	Variable Dimensions [in]		Brake static friction torque [oz · in]	Mass [lb]
			L	KL		
HC-RF103B HC-RFS103B	1.0	10.12	7.28	2.80	991	13.2
HC-RF153B HC-RFS153B	1.5	12.30	8.27	3.78	991	15.4
HC-RF203B HC-RFS203B	2.0	14.49	9.25	4.76	991	18.3

[Unit: in]

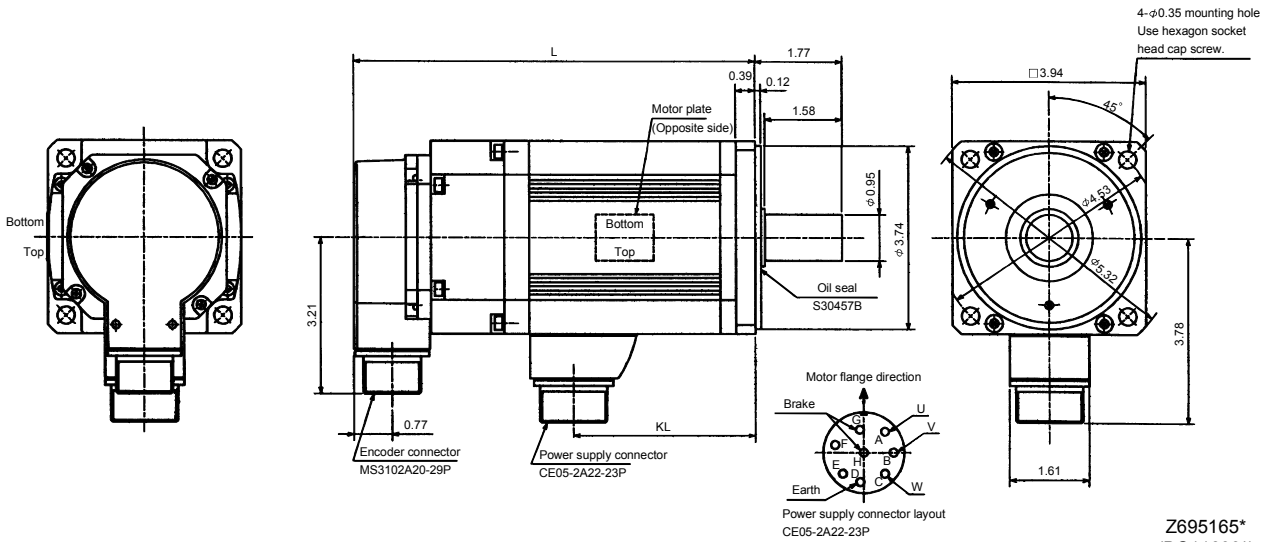

Z695165*
(BC11699*)

Model	Output [kW]	Variable Dimensions [in]		Brake static friction torque [oz · in]	Inertia Moment WK^2 [oz · in ²]	Mass [lb]
		L	KL			
HC-RF353B HC-RFS353B	3.5	10	5.827	2365	64.516	33.1
HC-RF503B HC-RFS503B	5.0	12.244	8.071	2365	84.745	46.3

[Unit: in]

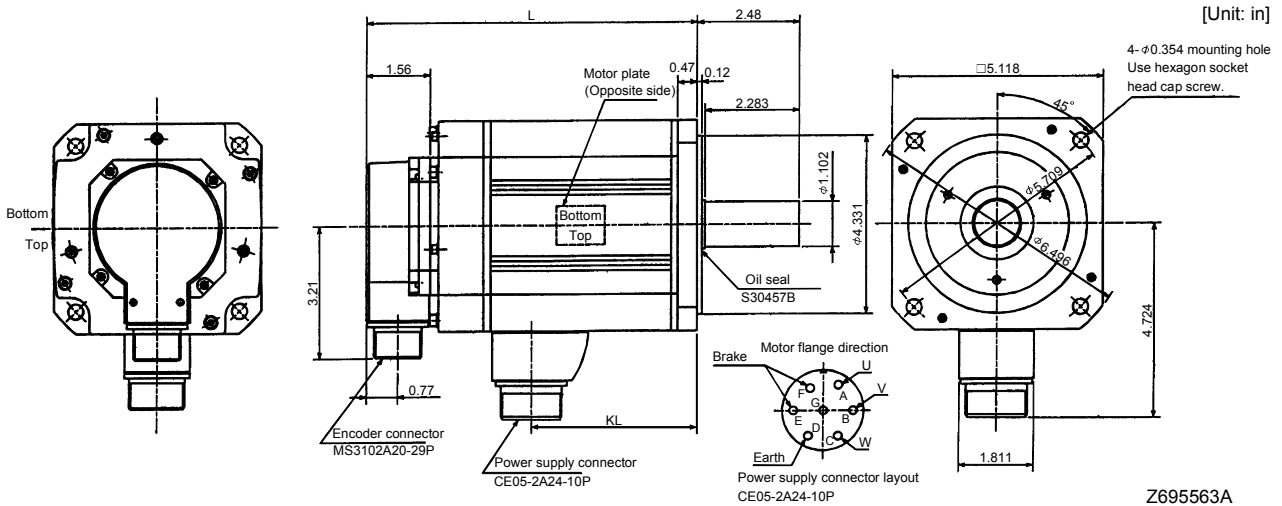

Z695563A
(BC11700*)

7. OUTLINE DIMENSION DRAWINGS

(3) With reduction gear for precision application

The outer frame of the reduction gear is a material surface such as casting. Its actual dimensions may be 0.039 to 0.118 in larger than the drawing dimensions. Design the machine side with allowances.

(a) Without electromagnetic brake

Model	Output [kW]	Reduction Gear Model	Reduction Ratio	Inertia Moment WK^2 [oz · in ²]	Variable Dimensions [in]		Mass [lb]
					L	KL	
HC-RF103G2 HC-RFS103G2	1.0	BL2-05B-10MEKD	1/5	27.06	11.85	6.06	26.2
HC-RF103G2 HC-RFS103G2	1.0	BL2-09B-10MEKD	1/9	25.15	12.32	6.54	26.2
HC-RF153G2 HC-RFS153G2	1.5	BL2-05B-15MEKD	1/5	29.25	12.84	6.06	28.7
HC-RF203G2 HC-RFS203G2	2.0	BL2-05B-20MEKD	1/5	31.44	13.82	6.06	31.3

[Unit: in]

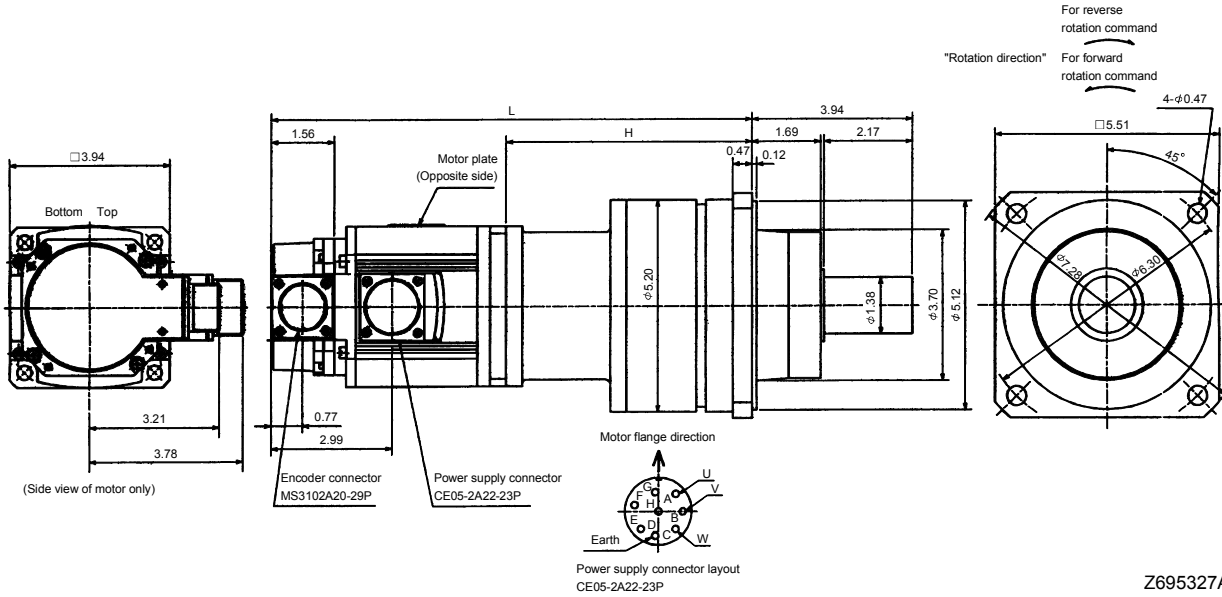

Z695327A

Model	Output [kW]	Reduction Gear Model	Reduction Ratio	Inertia Moment WK^2 [oz · in ²]	Variable Dimensions [in]			Mass [lb]
					L	H	LI	
HC-RF103G2 HC-RFS103G2	1.0	BL3-20B-10MEKD	1/20	45.65	13.94	8.15	4.13	63.7
HC-RF103G2 HC-RFS103G2	1.0	BL3-29B-10MEKD	1/29	35.27	13.94	8.15	4.13	63.7
HC-RF103G2 HC-RFS103G2	1.0	BL3-45B-10MEKD	1/45	29.93	14.33	8.54	4.53	63.7
HC-RF153G2 HC-RFS153G2	1.5	BL3-09B-15MEKD	1/9	36.50	14.76	7.99	3.98	66.1
HC-RF153G2 HC-RFS153G2	1.5	BL3-20B-15MEKD	1/20	47.84	14.92	8.15	4.13	66.1
HC-RF153G2 HC-RFS153G2	1.5	BL3-29B-15MEKD	1/29	37.45	14.92	8.15	4.13	66.1
HC-RF203G2 HC-RFS203G2	2.0	BL3-09B-20MEKD	1/9	38.71	15.75	7.99	3.98	68.8
HC-RF203G2 HC-RFS203G2	2.0	BL3-20B-20MEKD	1/20	50.03	15.91	8.15	4.13	68.8

[Unit: in]

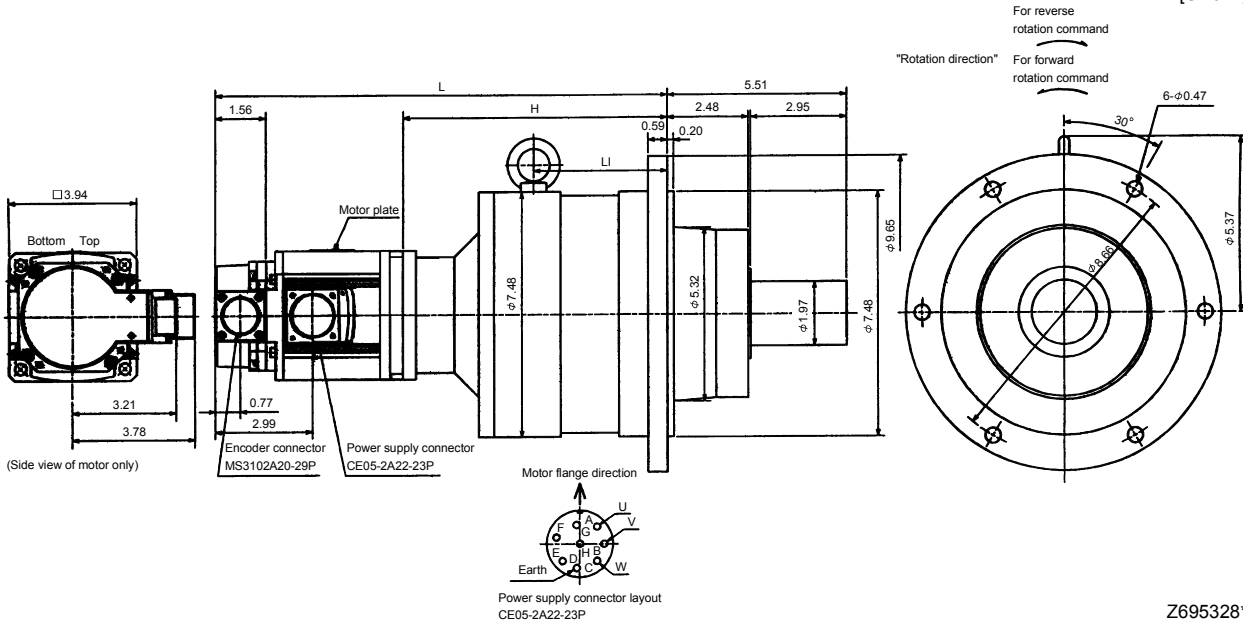

Z695328*

7. OUTLINE DIMENSION DRAWINGS

Model	Output [kW]	Reduction Gear Model	Reduction Ratio	Inertia Moment WK^2 [oz · in ²]	Variable Dimensions [in]			Mass [lb]	
					L	H	LI		
HC-RF353G2	HC-RFS353G2	3.5	BL4-09B-35MEKD	1/9	115.363	18.504	9.961	4.961	125.7
HC-RF353G2	HC-RFS353G2	3.5	BL4-20B-35MEKD	1/20	157.462	18.504	9.961	4.961	125.7
HC-RF353G2	HC-RFS353G2	3.5	BL4-29B-35MEKD	1/29	120.284	18.504	9.961	4.961	125.7
HC-RF503G2	HC-RFS503G2	5.0	BL4-05B-50MEKD	1/5	177.145	19.488	8.701	3.701	114.6
HC-RF503G2	HC-RFS503G2	5.0	BL4-09B-50MEKD	1/9	133.952	20.748	9.961	4.961	136.7
HC-RF503G2	HC-RFS503G2	5.0	BL4-20B-50MEKD	1/20	176.052	20.748	9.961	4.961	136.7

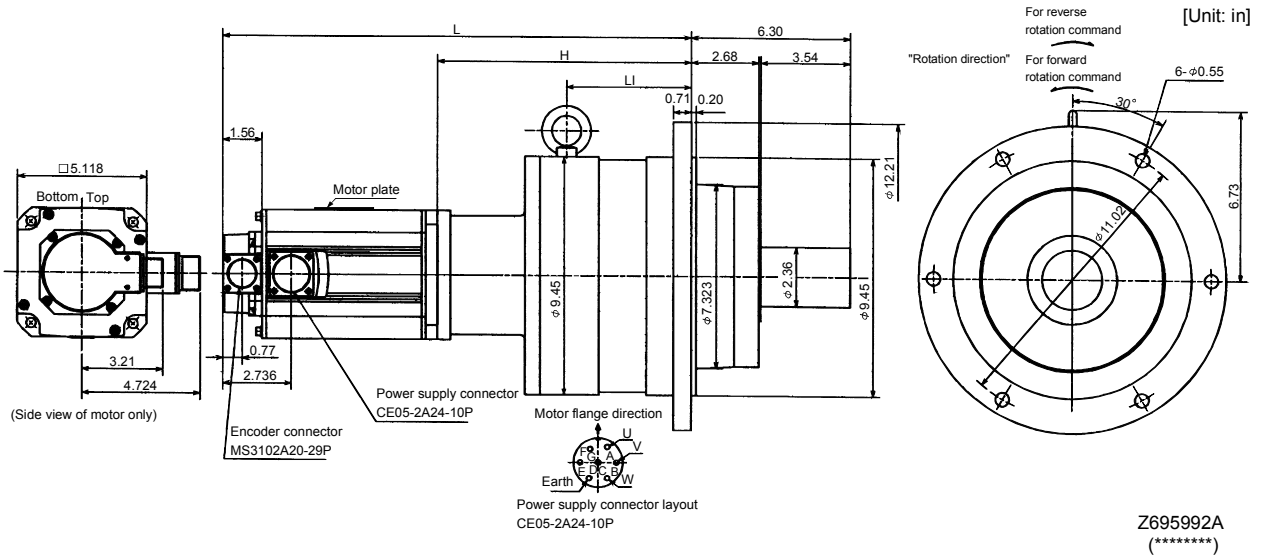

(b) With electromagnetic brake

Model	Output [kW]	Reduction Gear Model	Reduction Ratio	Inertia Moment WK^2 [oz · in ²]	Variable Dimensions [in]		Brake static friction torque [oz · in]	Mass (lb)	
					L	H			
HC-RF103BG2	HC-RFS103BG2	1.0	BL2-05B-10MEKD	1/5	28.98	13.35	6.06	991	30.9
HC-RF103BG2	HC-RFS103BG2	1.0	BL2-09B-10MEKD	1/9	27.06	13.82	6.54	991	30.9
HC-RF153BG2	HC-RFS153BG2	1.5	BL2-05B-15MEKD	1/5	31.16	14.33	6.06	991	33.3
HC-RF203BG2	HC-RFS203BG2	2.0	BL2-05B-20MEKD	1/5	33.35	15.32	6.06	991	35.9

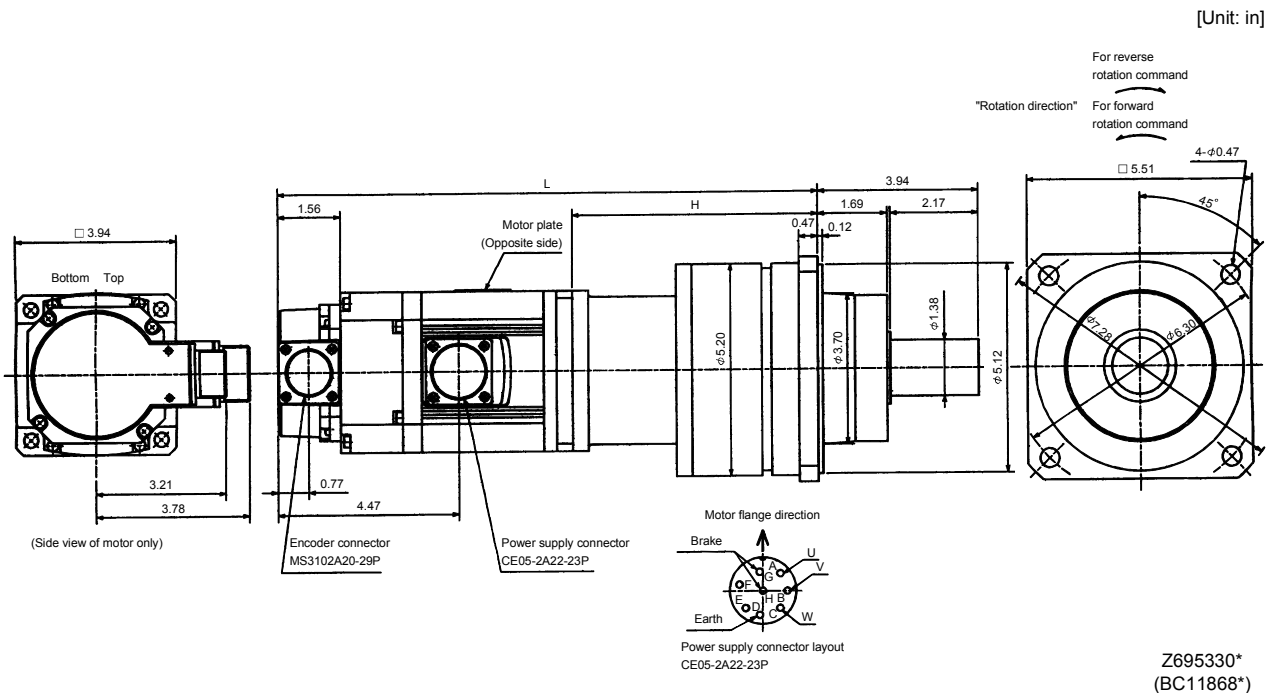

7. OUTLINE DIMENSION DRAWINGS

Model	Output [kW]	Reduction Gear Model	Reduction Ratio	Inertia Moment WK^2 [oz · in ²]	Variable Dimensions [in]			Brake static friction torque [oz · in]	Mass [lb]
					L	H	LI		
HC-RF103BG2 HC-RFS103BG2	1.0	BL3-20B-10MEKD	1/20	47.57	15.43	8.15	4.13	991	68.3
HC-RF103BG2 HC-RFS103BG2	1.0	BL3-29B-10MEKD	1/29	37.18	15.43	8.15	4.13	991	68.3
HC-RF103BG2 HC-RFS103BG2	1.0	BL3-45B-10MEKD	1/45	31.85	15.83	8.54	4.53	991	68.3
HC-RF153BG2 HC-RFS153BG2	1.5	BL3-09B-15MEKD	1/9	38.41	16.26	7.99	3.98	991	70.8
HC-RF153BG2 HC-RFS153BG2	1.5	BL3-20B-15MEKD	1/20	49.75	16.42	8.15	4.13	991	70.8
HC-RF153BG2 HC-RFS153BG2	1.5	BL3-29B-15MEKD	1/29	39.37	16.42	8.15	4.13	991	70.8
HC-RF203BG2 HC-RFS203BG2	2.0	BL3-09B-20MEKD	1/9	40.60	17.24	7.99	3.98	991	73.4
HC-RF203BG2 HC-RFS203BG2	2.0	BL3-20B-20MEKD	1/20	51.94	17.40	8.15	4.13	991	73.4

[Unit: in]

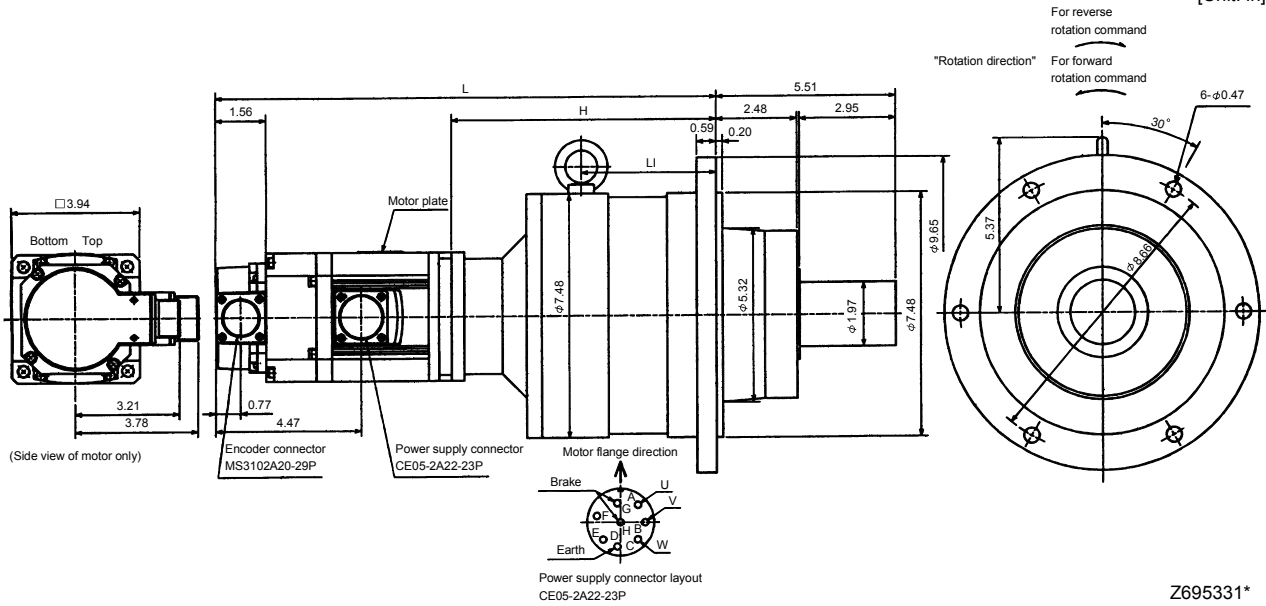

Z695331*
(BC11869*)

Model	Output [kW]	Reduction Gear Model	Reduction Ratio	Inertia Moment WK^2 [oz · in ²]	Variable Dimensions [in]			Brake static friction torque [oz · in]	Mass [lb]
					L	H	LI		
HC-RF153BG2 HC-RFS153BG2	1.5	BL4-45B-15MEKD	1/45	48.66	17.64	9.37	5.35	991	114.9
HC-RF203BG2 HC-RFS203BG2	2.0	BL4-29B-20MEKD	1/29	71.35	18.23	8.98	4.96	991	117.5
HC-RF203BG2 HC-RFS203BG2	2.0	BL4-45B-20MEKD	1/45	50.85	18.62	9.37	5.35	991	117.5

[Unit: in]

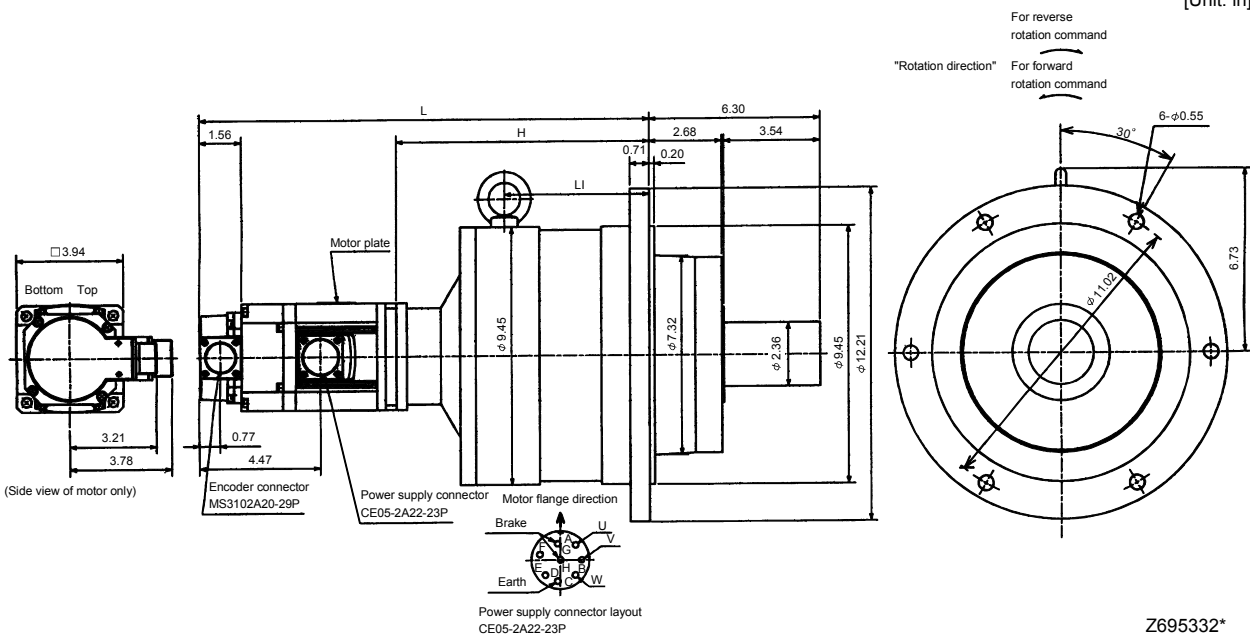

Z695332*
(BC11870*)

7. OUTLINE DIMENSION DRAWINGS

Model	Output [kW]	Reduction Gear Model	Reduction Ratio	Brake static friction torque [oz · in]	Inertia Moment WK ² [oz · in ²]	Mass [lb]
HC-RF353BG2 HC-RFS353BG2	3.5	BL3-05B-35MEKD	1/5	2365	113.723	72.8

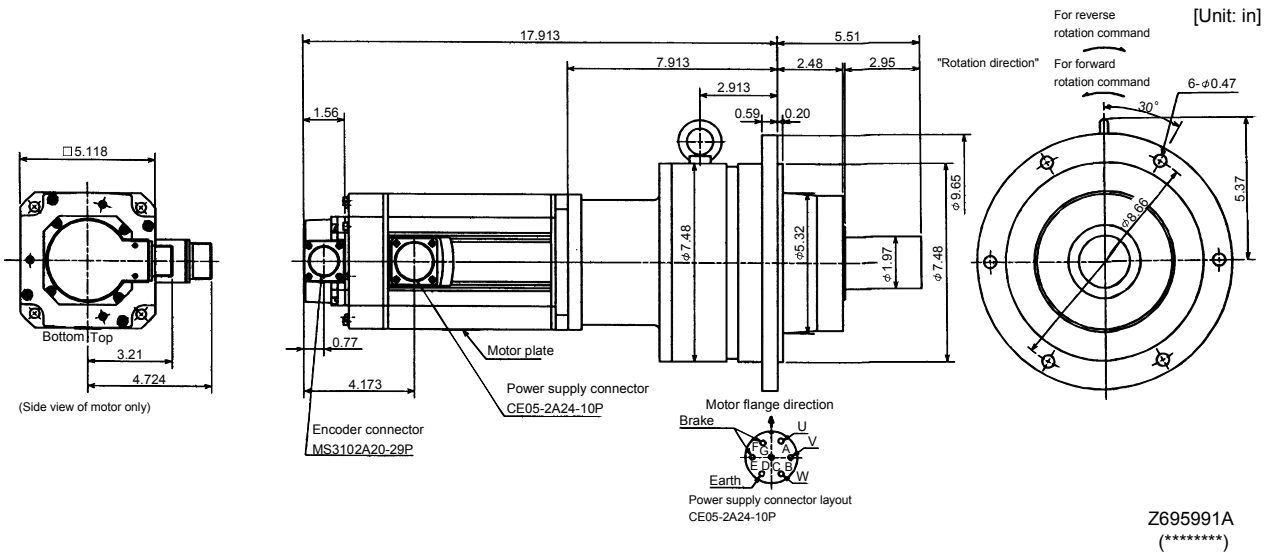

Model	Output [kW]	Reduction Gear Model	Reduction Ratio	Variable Dimensions [in]			Brake static friction torque [oz · in]	Inertia Moment WK ² [oz · in ²]	Mass [lb]
				L	H	LI			
HC-RF353BG2 HC-RFS353BG2	3.5	BL4-09B-35MEKD	1/9	19.961	9.961	4.961	2365	126.298	132.3
HC-RF353BG2 HC-RFS353BG2	3.5	BL4-20B-35MEKD	1/20	19.961	9.961	4.961	2365	168.397	132.3
HC-RF353BG2 HC-RFS353BG2	3.5	BL4-29B-35MEKD	1/29	19.961	9.961	4.961	2365	120.284	132.3
HC-RF503BG2 HC-RFS503BG2	5.0	BL4-05B-50MEKD	1/5	20.945	8.701	3.701	2365	188.08	123.5
HC-RF503BG2 HC-RFS503BG2	5.0	BL4-09B-50MEKD	1/9	22.205	9.961	4.961	2365	144.887	145.5
HC-RF503BG2 HC-RFS503BG2	5.0	BL4-20B-50MEKD	1/20	22.205	9.961	4.961	2365	186.987	145.5

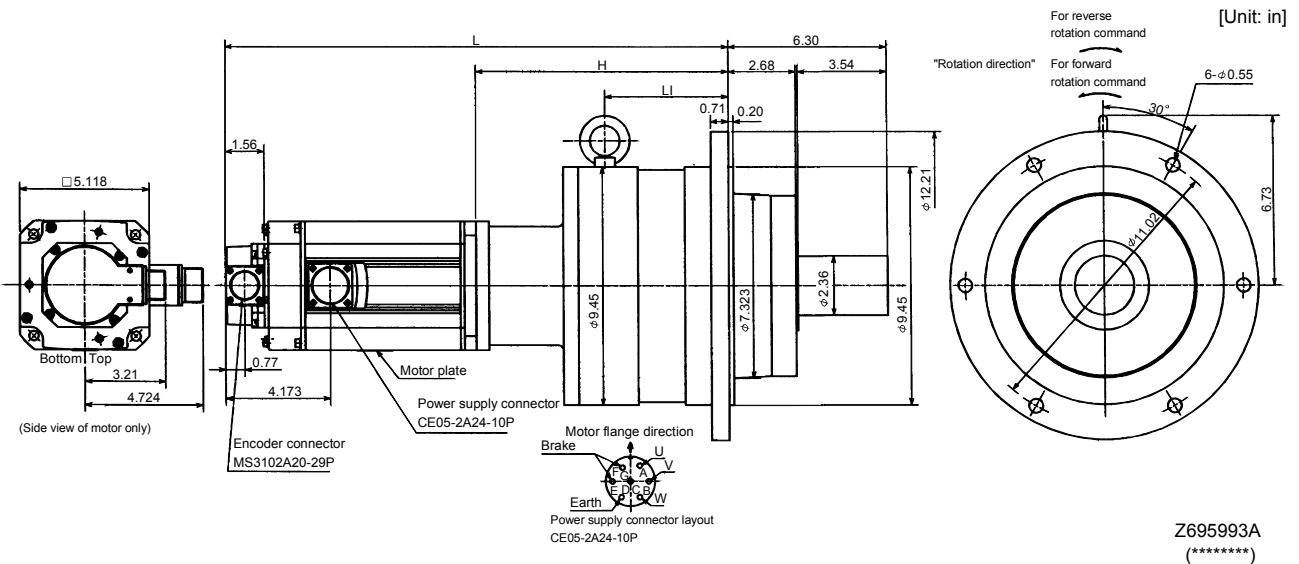

7. OUTLINE DIMENSION DRAWINGS

7.2.5 HC-UF 2000r/min · HC-UFS 2000r/min series

(1) Standard (without electromagnetic brake)

Model	Output [kW]	Inertia Moment WK^2 [oz · in ²]	Mass [lb]
HC-UF72 HC-UFS72	0.75	56.861	17.6

[Unit: in]

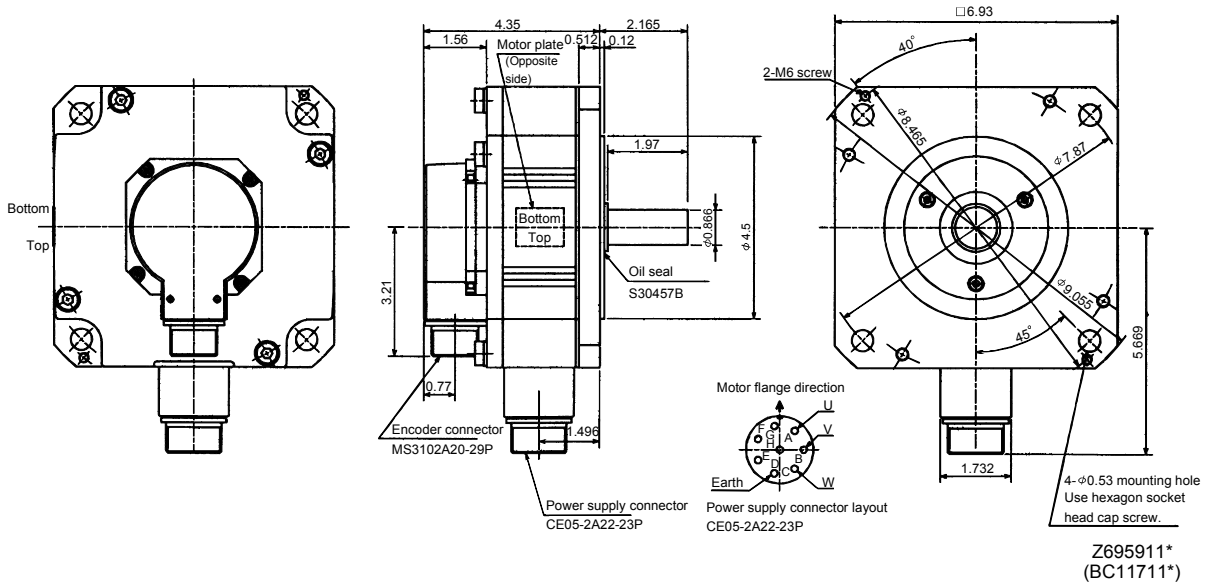

Model	Output [kW]	Inertia Moment WK^2 [oz · in ²]	Mass [lb]
HC-UF152 HC-UFS152	1.5	120.831	24.3

[Unit: in]

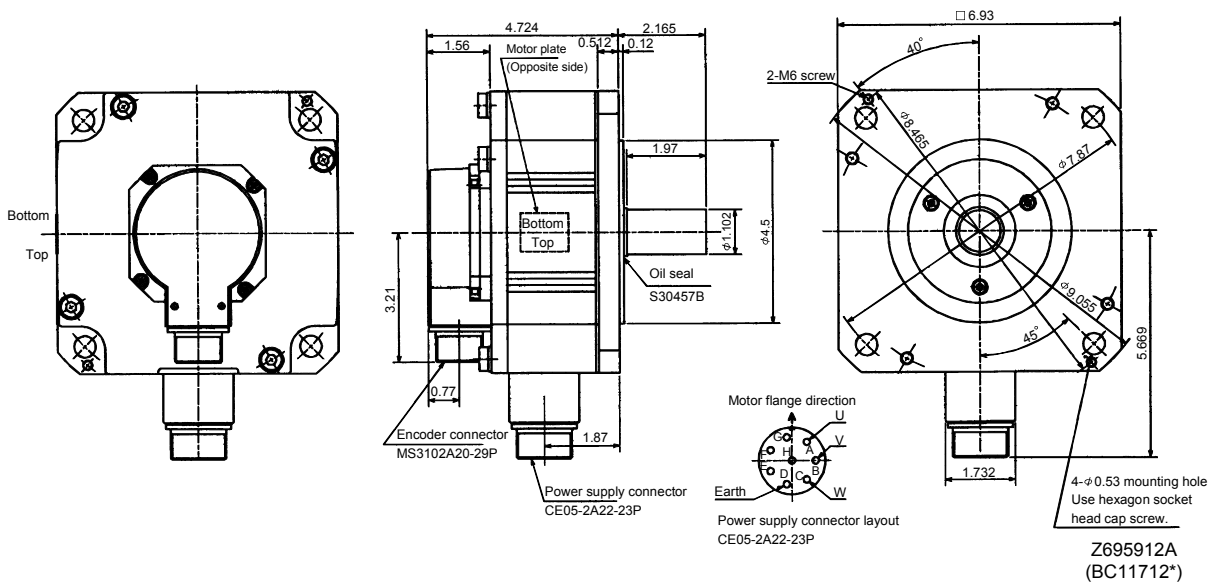

7. OUTLINE DIMENSION DRAWINGS

Model	Output [kW]	Brake static friction torque [oz · in]	Inertia Moment WK^2 [oz · in ²]	Mass [lb]
HC-UF152B HC-UFS152B	1.5	1204	131.765	28.7

[Unit: in]

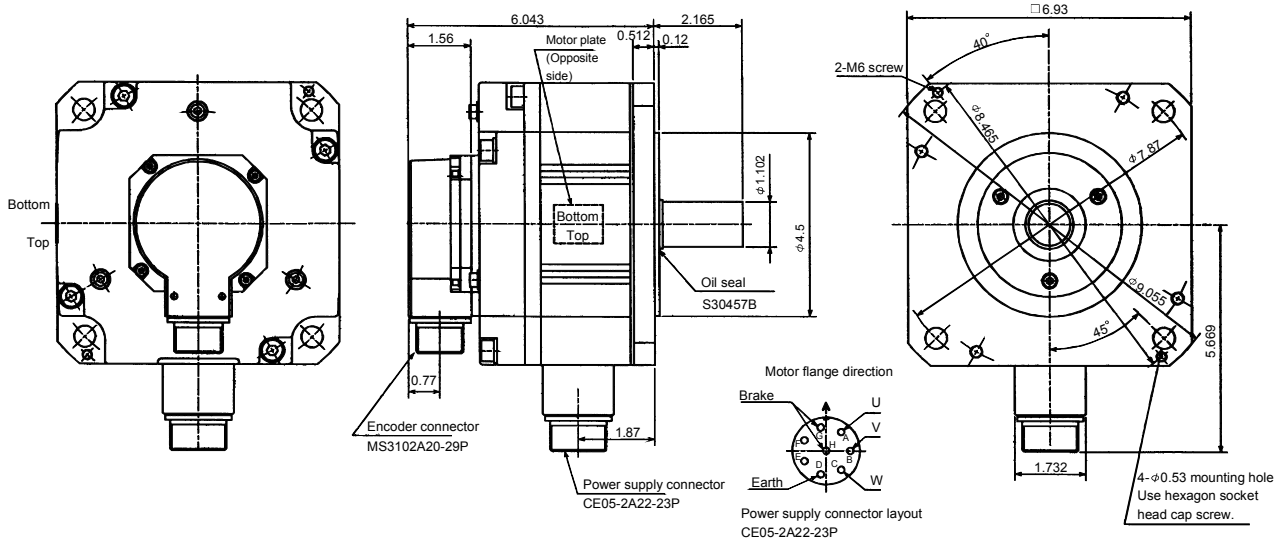

Z695982B
(BC11715*)

Model	Output [kW]	Variable Dimensions [in]		Brake static friction torque [oz · in]	Inertia Moment WK^2 [oz · in ²]	Mass [lb]
		L	KL			
HC-UF202B HC-UFS202B	2.0	6.339	1.673	6103	255.876	48.5
HC-UF352B HC-UFS352B	3.5	7.283	2.618	6103	465.28	57.3
HC-UF502B HC-UFS502B	5.0	8.228	3.563	6103	675.776	66.1

[Unit: in]

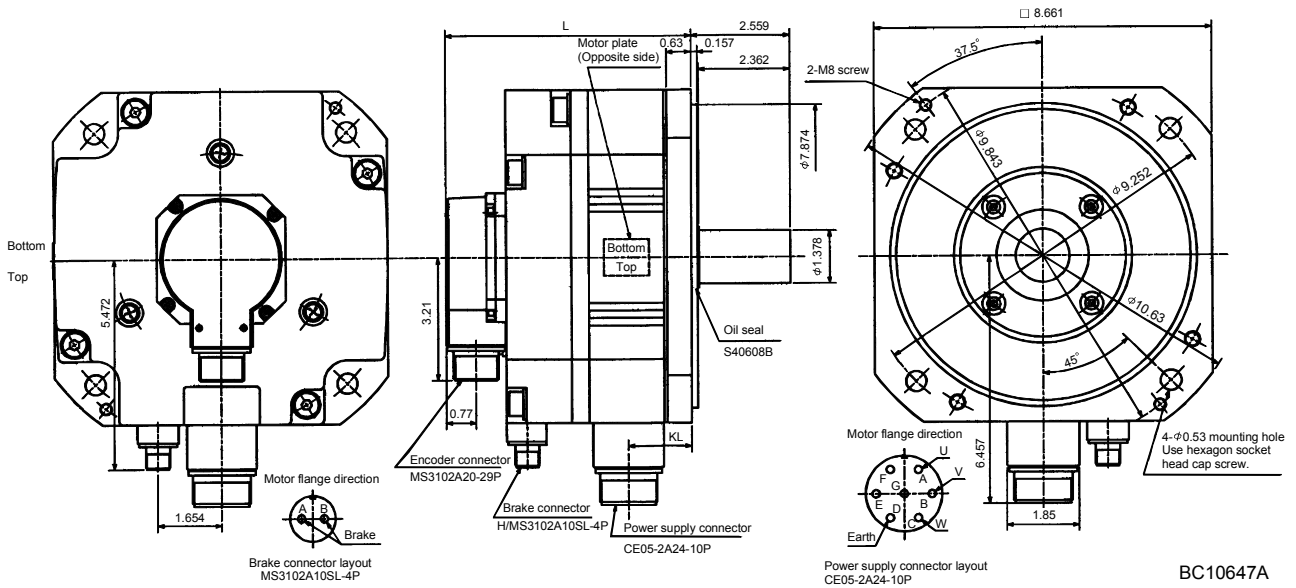

BC10647A
(BC12766*)

7. OUTLINE DIMENSION DRAWINGS

7.2.6 HC-UF 3000r/min series

(1) Standard (without electromagnetic brake)

Model	Output [W]	Inertia Moment WK ² [oz · in ²]	Mass [lb]
HC-UF13	100	0.361	1.8

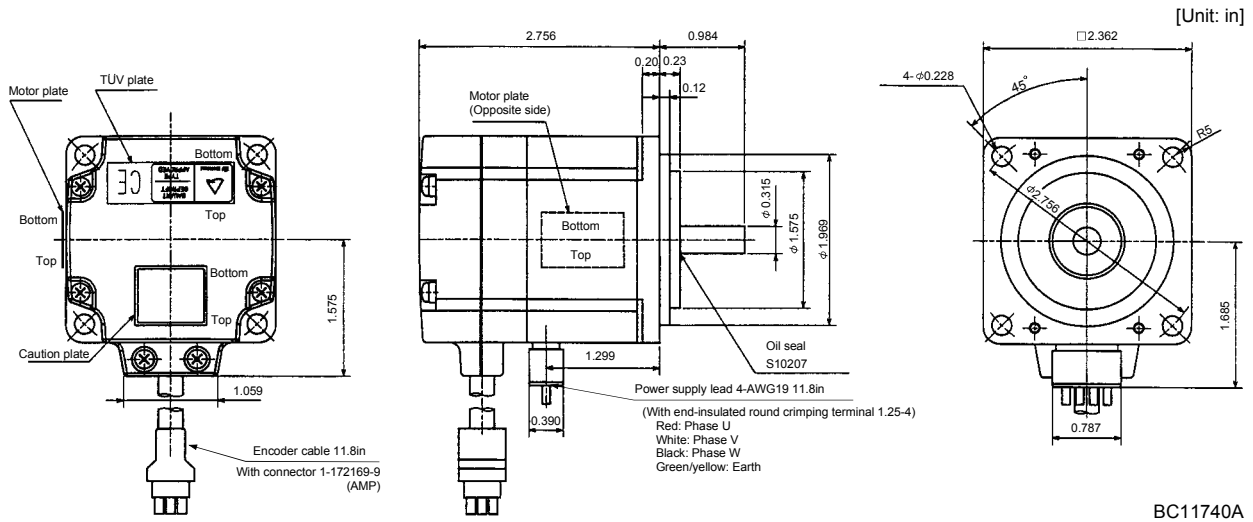

Model	Output [W]	Variable Dimensions [in]		Inertia Moment WK ² [oz · in ²]	Mass [lb]
		L	KL		
HC-UF23	200	2.953	1.724	1.318	3.3
HC-UF43	400	3.543	2.315	1.996	3.7

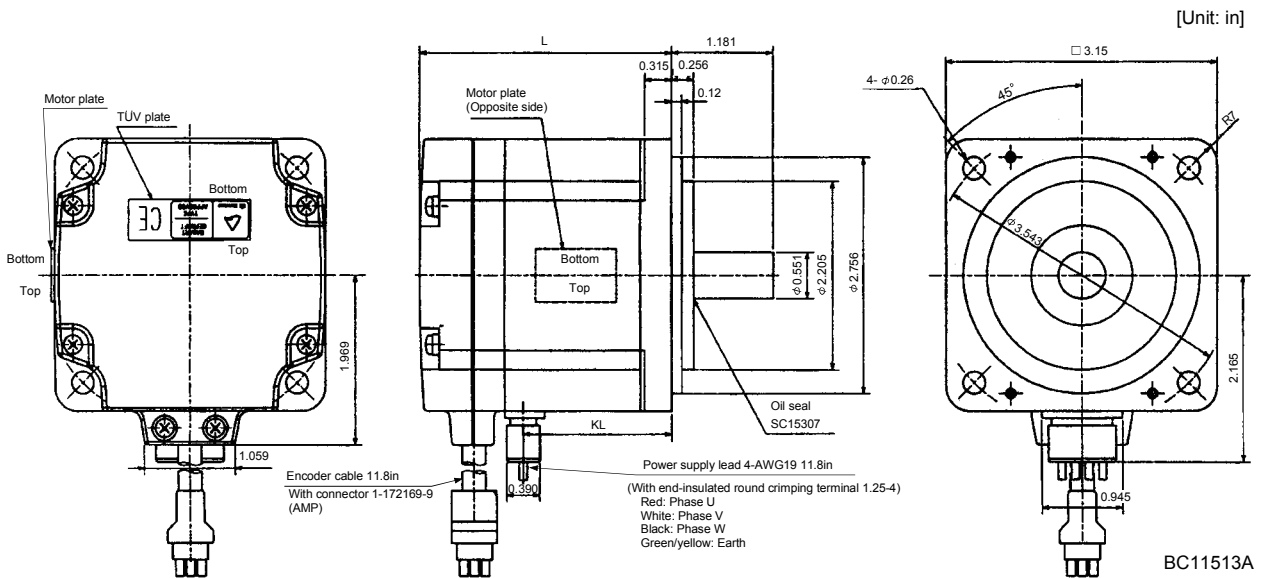

7. OUTLINE DIMENSION DRAWINGS

Model	Output [W]	Inertia Moment WK ² [oz · in ²]	Mass [lb]
HC-UF73	750	32.258	11.0

[Unit: in]

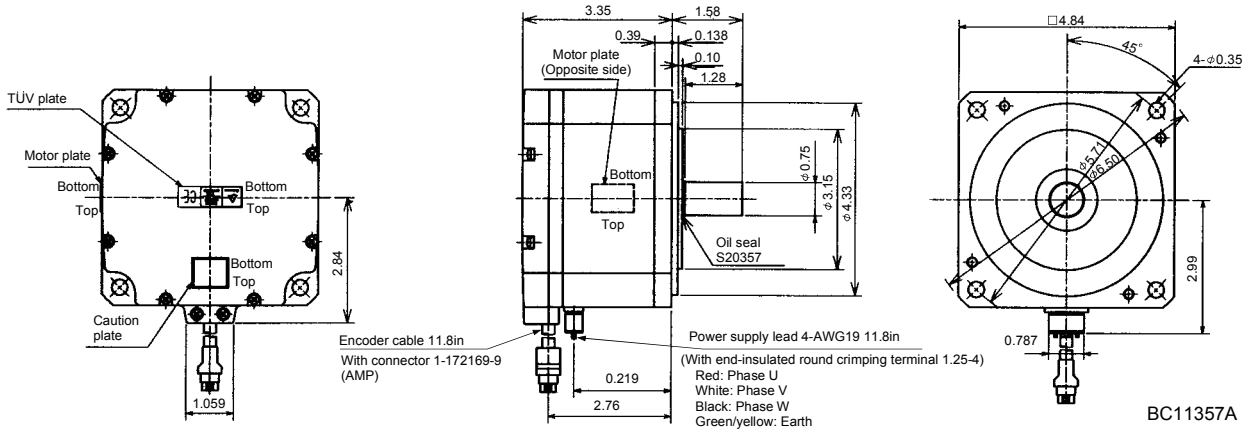

BC11357A

(2) With electromagnetic brake

Model	Output [W]	Brake static friction torque [oz · in]	Inertia Moment WK ² [oz · in ²]	Mass [lb]
HC-UF13B	100	45	0.405	2.6

[Unit: in]

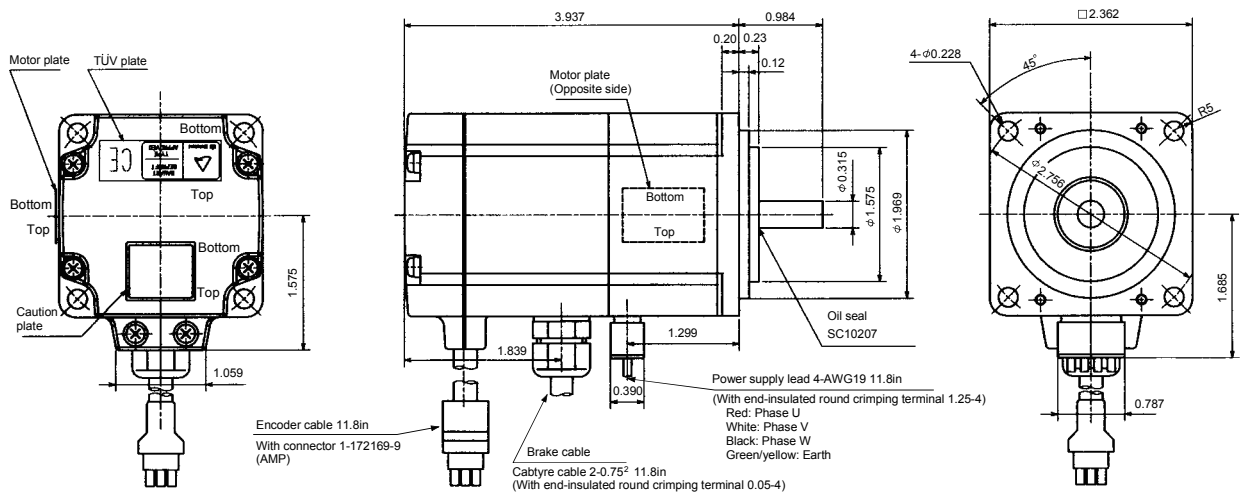

BC11767A

7. OUTLINE DIMENSION DRAWINGS

Model	Output [W]	Variable Dimensions [in]		Brake static friction torque [oz · in]	Inertia Moment WK ² [oz · in ²]	Mass [lb]
		L	KL			
HC-UF23B	200	4.291	1.724	184	1.766	4.9
HC-UF43B	400	4.882	2.315	184	2.444	5.3

[Unit: in]

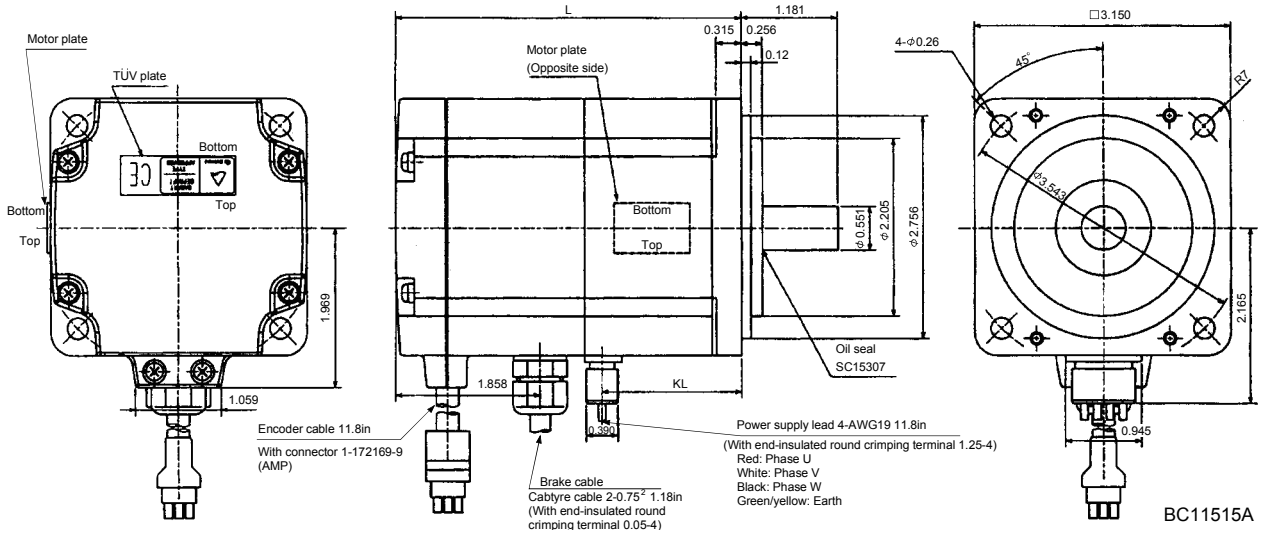

Model	Output [W]	Brake static friction torque [oz · in]	Inertia Moment WK ² [oz · in ²]	Mass [lb]
HC-UF73B	750	339.87	33.35	13.7

[Unit: in]

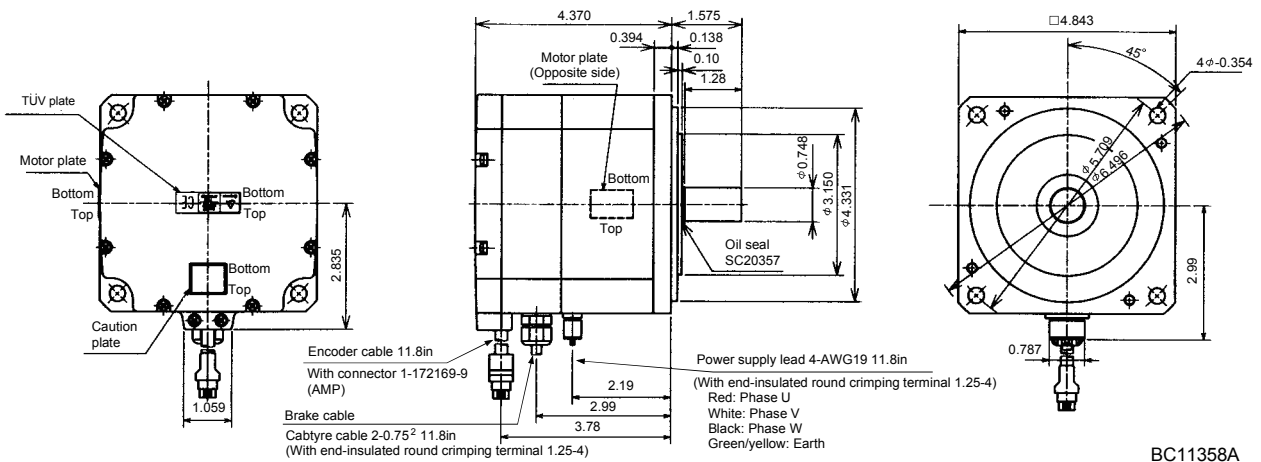

7. OUTLINE DIMENSION DRAWINGS

7.2.7 HC-UF3000r/min, HC-UFS3000r/min series with IP65-compliant connectors

(1) Without electromagnetic brake

Model		Output [W]	Inertia Moment WK^2 [oz · in ²]	Mass [lb]
HC-UF13-S1	HC-UFS13-S1	100	0.361	1.8

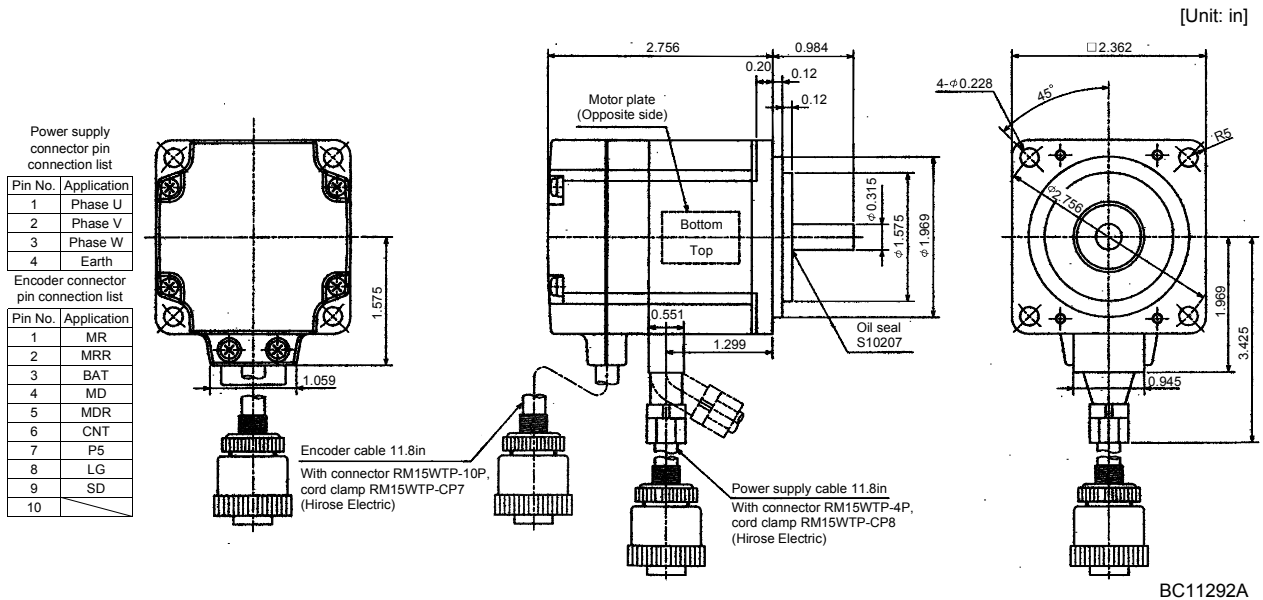

Model		Output [W]	Variable Dimensions [in]		Inertia Moment WK^2 [oz · in ²]	Mass [lb]
			L	KL		
HC-UF23-S1	HC-UFS23-S1	200	0.2953	1.732	1.318	3.3
HC-UF43-S1	HC-UFS43-S1	400	3.543	2.323	1.996	3.7

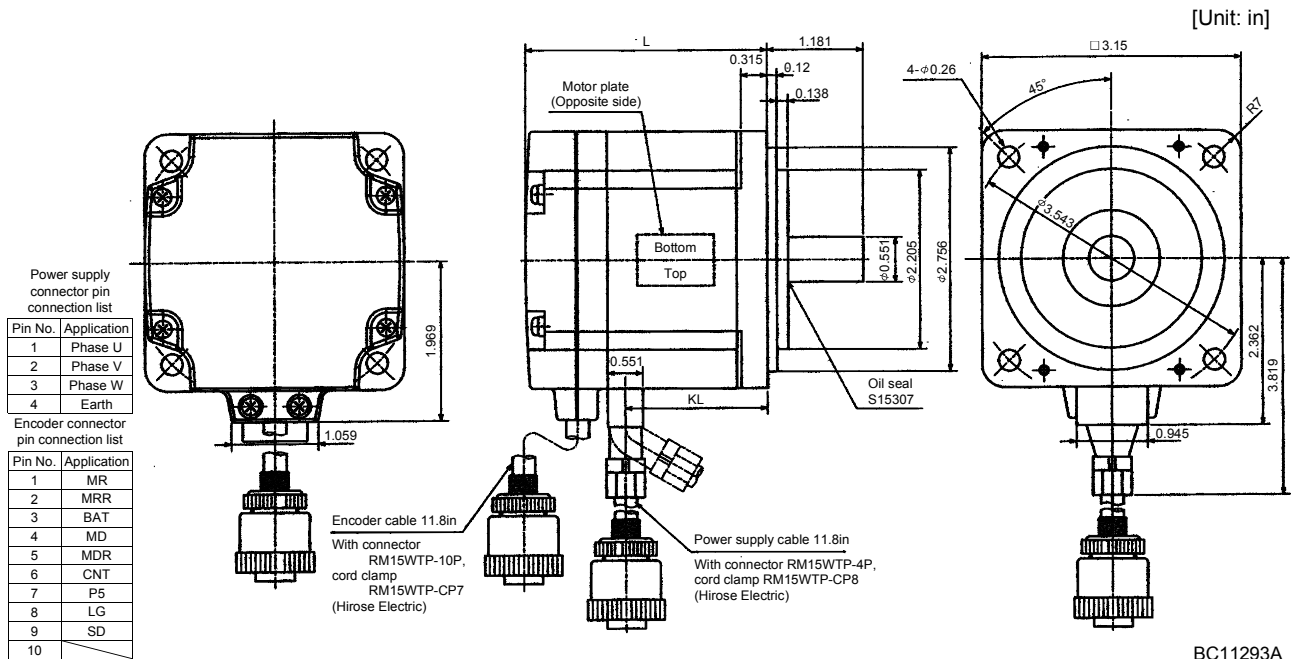

7. OUTLINE DIMENSION DRAWINGS

Model		Output [W]	Inertia Moment WK^2 [oz · in ²]	Mass [lb]
HC-UF73-S1	HC-UFS73-S1	750	32.258	11.0

[Unit: in]

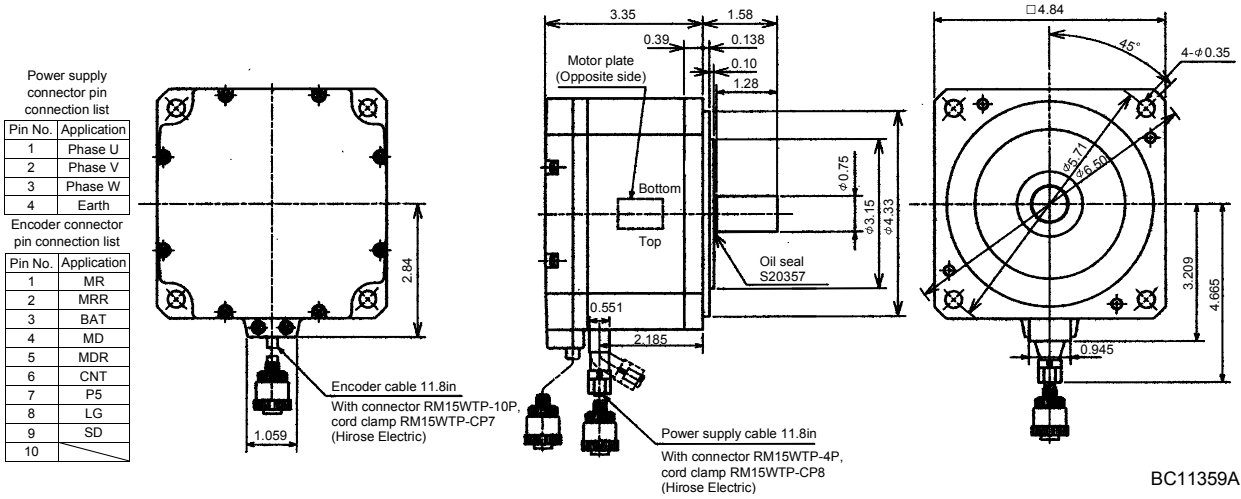

(2) With electromagnetic brake

Model		Output [W]	Brake static friction torque [oz · in]	Inertia Moment WK^2 [oz · in ²]	Mass [lb]
HC-UF13B-S1	HC-UFS13B-S1	100	45	0.405	2.6

[Unit: in]

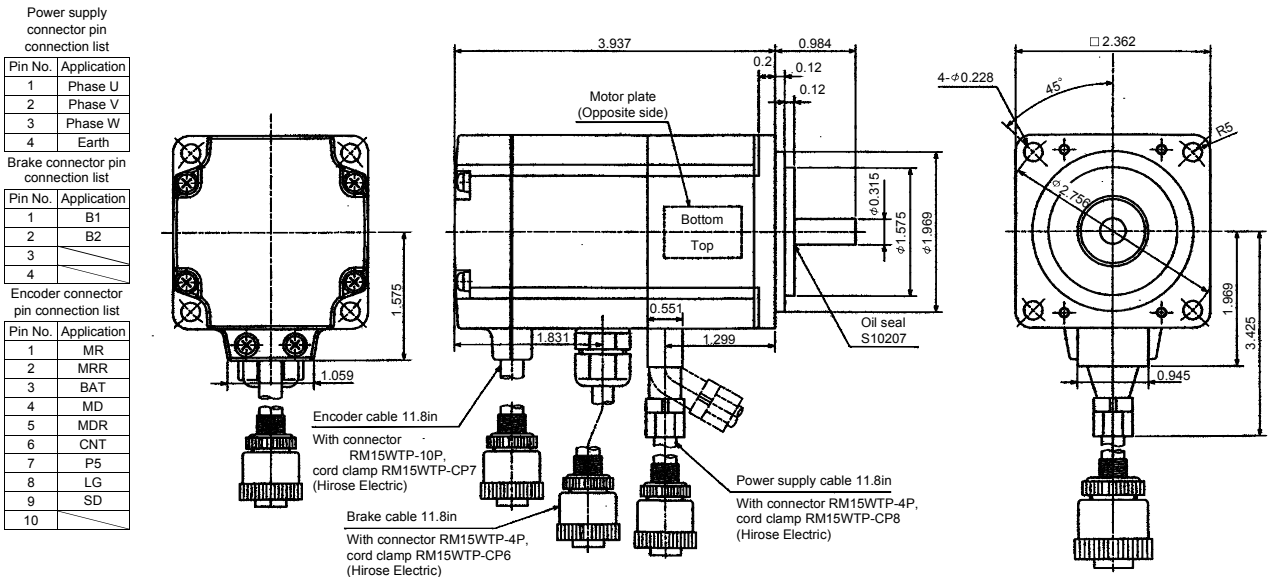

7. OUTLINE DIMENSION DRAWINGS

Model	Output [W]	Variable Dimensions [in]		Brake static friction torque [oz · in]	Inertia Moment WK ² [oz · in ²]	Mass [lb]
		L	KL			
HC-UF23B-S1 HC-UFS23B-S1	200	4.291	1.732	184	1.766	4.9
HC-UF43B-S1 HC-UFS43B-S1	400	4.882	2.323	184	2.444	5.3

[Unit: in]

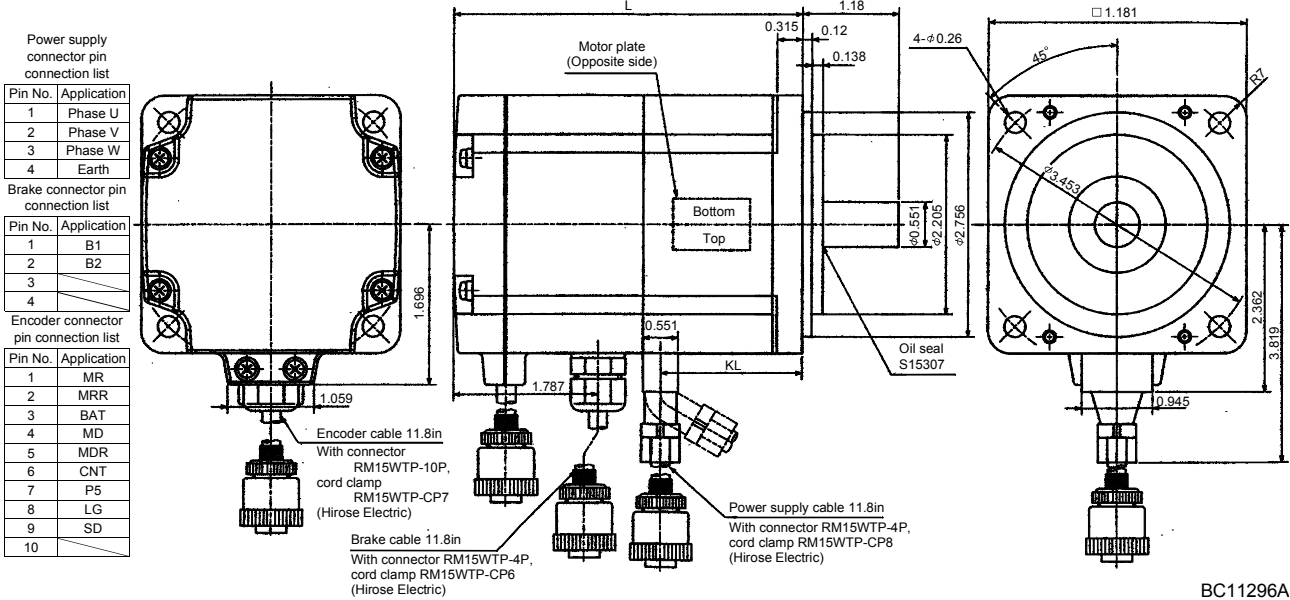

BC11296A

Model	Output [W]	Brake static friction torque [oz · in]	Inertia Moment WK ² [oz · in ²]	Mass [lb]
HC-UF73B-S1 HC-UFS73B-S1	750	339.869	33.351	13.7

[Unit: in]

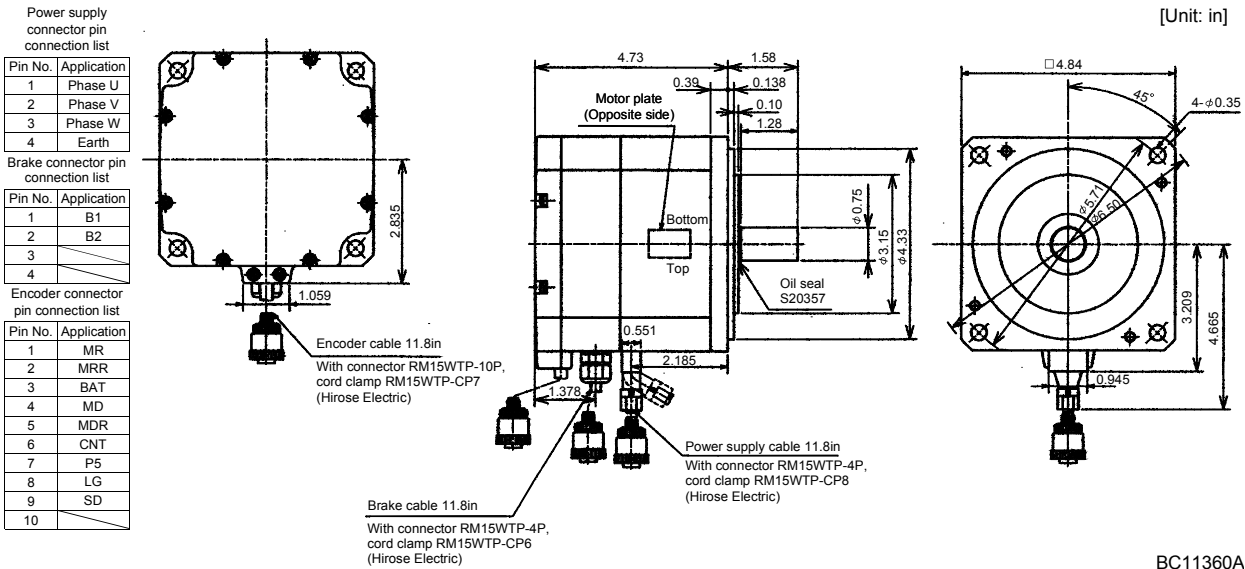

BC11360A

7. OUTLINE DIMENSION DRAWINGS

7.2.8 HA-LH series

(1) Standard (without electromagnetic brake)

Model	Variable Dimensions [in]																Inertia Moment WK ² [oz · in ²]	Oil Seal	Mass [lb]	
	F	L	LA	LB	LC	LD	LG	LT	KL	KH	IE	IF	Hanger	E	LR	Q				S
HA-LH11K2(-Y)	8.189	20.827	8.465	7.087	9.843	8.031	0.787	12.441	18.819	4.016	5.984	12.48	M10	0.118	3.346	3.15	1.654	645.16	S45629B	46.30
HA-LH15K2(-Y)	10	22.756	10.433	9.055	11.811	9.843	0.984	14.252	20.948	4.606	7.087	14.803	M12	0.197	4.331	3.937	2.165	1585.56	S608295	37.48
HA-LH22K2(-Y)		16.929						23.307	2159.64									66.14		

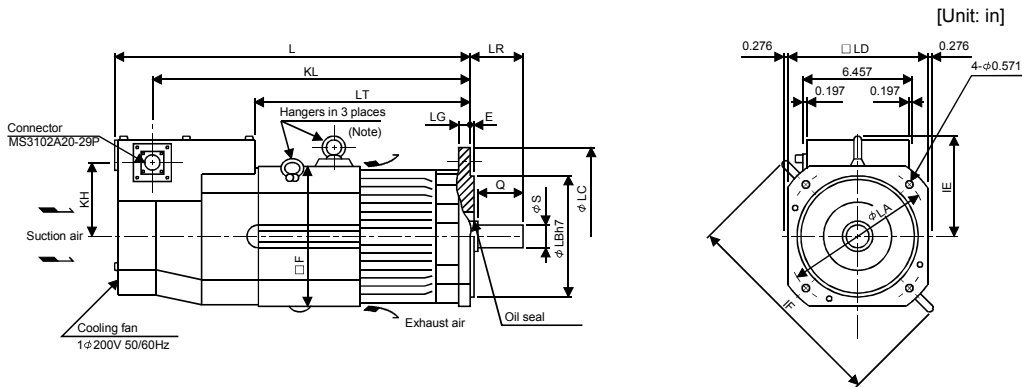

Note: When using the motor without the hangers, plug the screw holes with the following bolts:
 HA-LH11K2: M10 × 0.591in max.
 HA-LH15K2, 22K2: M12 × 0.709in max.

Terminal Box of HA-LH11K2 to 22K2

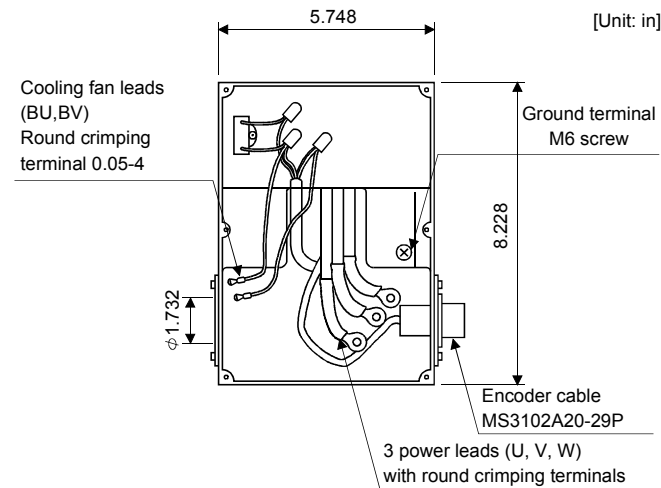

Power Connection Screw Size

Servo Motor	Power Connection Screw Size
HA-LH11K2	8-6
HA-LH15K2 · 22K2	14-6

7. OUTLINE DIMENSION DRAWINGS

(2) EN • UL/C-UL Standard-Compliant model

Model	Output [W]	Inertia Moment WK^2 [oz · in ²]	Mass [lb]
HA-LH11K2-EC	11	642.425	154.3

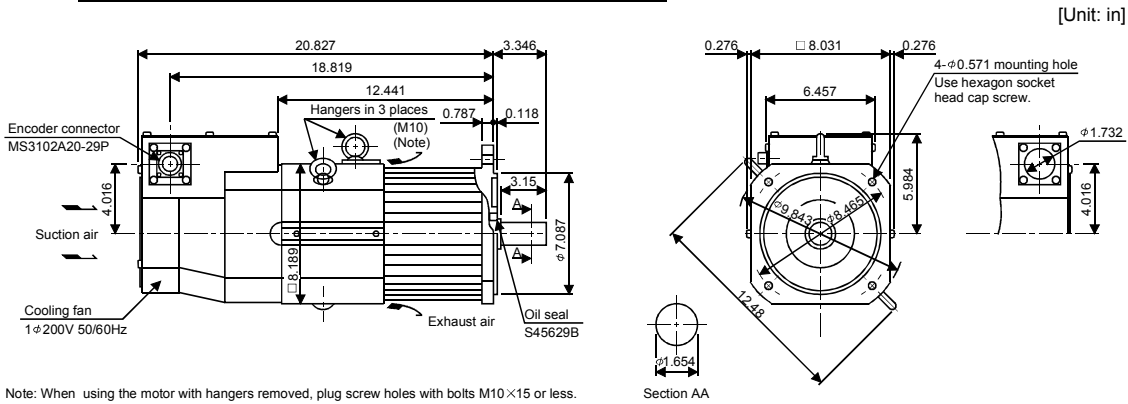

Model	Output [W]	Variable Dimensions [in]			Inertia Moment WK^2 [oz · in ²]	Mass [lb]
		L	KL	LT		
HA-LH15K2-EC	15	22.756	20.748	14.252	1585.559	238.1
HA-LH22K2-EC	22	25.315	23.307	16.929	2159.641	297.6

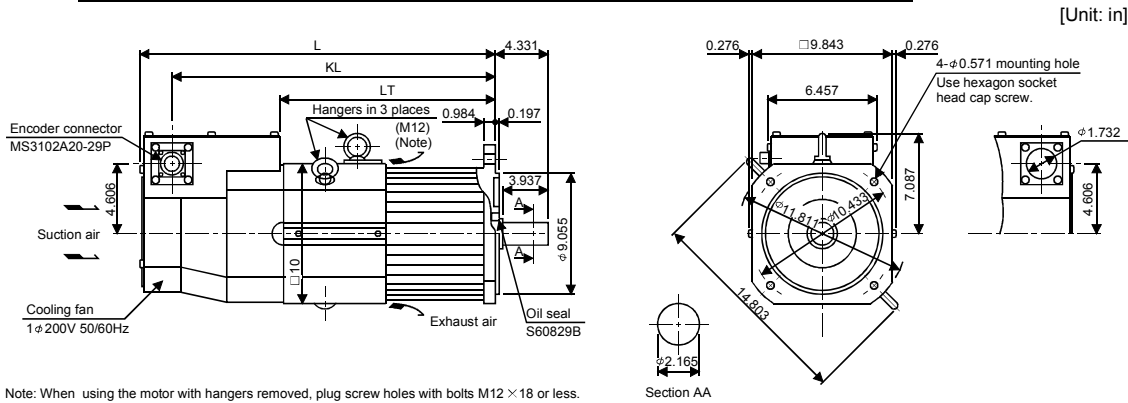

Terminal Box of HA-LH11K2-EC to 22K2-EC

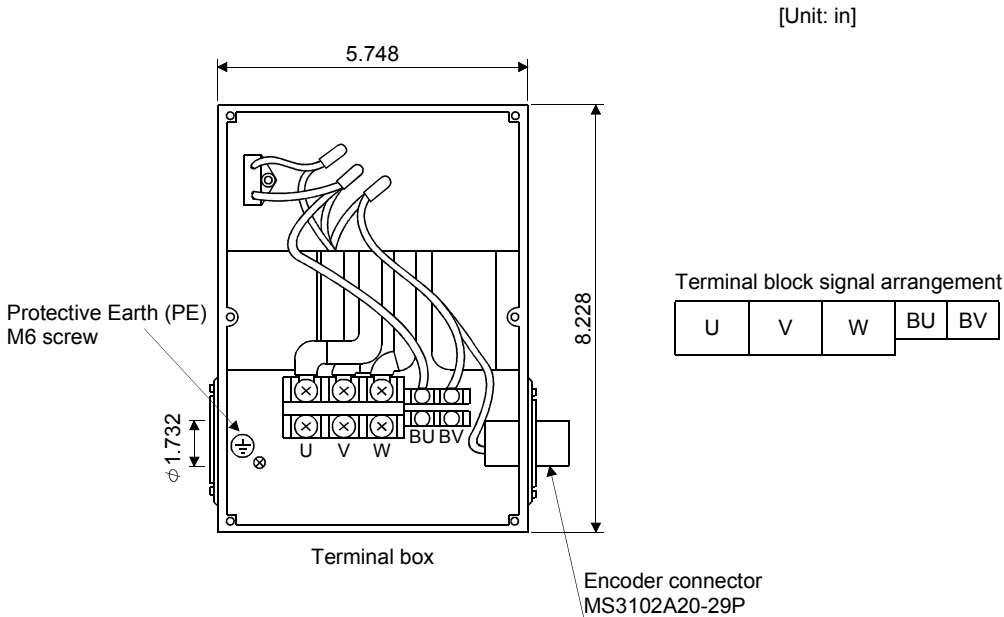

Model	Power Connection Screw Size	Cooling fan Connection Screw Size
HA-LH11K2-EC	M6	M4
HA-LH15K2-EC • 22K2-EC	M8	M4

7. OUTLINE DIMENSION DRAWINGS

7.2.9 HC-AQ series

(1) Standard (without electromagnetic brake)

Model	Output [W]	Variable Dimensions [in]	Inertia Moment WK ² [oz · in ²]	Mass [lb]
		L		
HC-AQ0135D	10	2.126	0.027	0.419
HC-AQ0235D	20	2.402	0.039	0.485
HC-AQ0335D	30	2.677	0.051	0.551

[Unit: in]

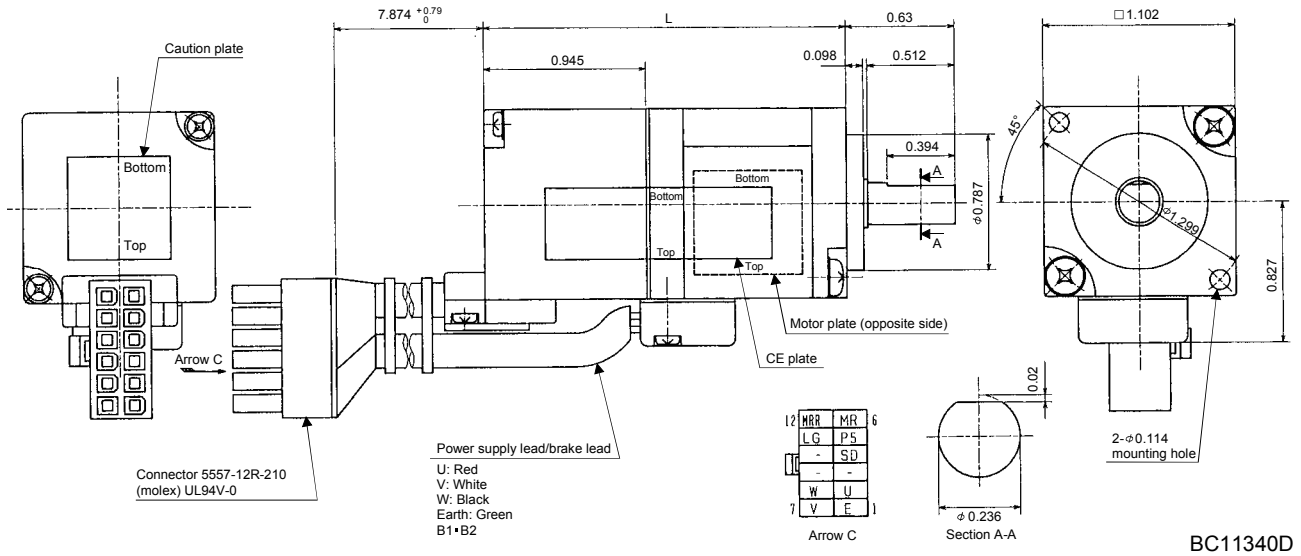

(2) With electromagnetic brake

Model	Output [W]	Variable Dimensions [in]	Inertia Moment WK ² [oz · in ²]	Mass [lb]
		L		
HC-AQ0135BD	10	3.189	0.05	0.639
HC-AQ0235BD	20	3.465	0.062	0.705
HC-AQ0335BD	30	3.74	0.074	0.772

[Unit: in]

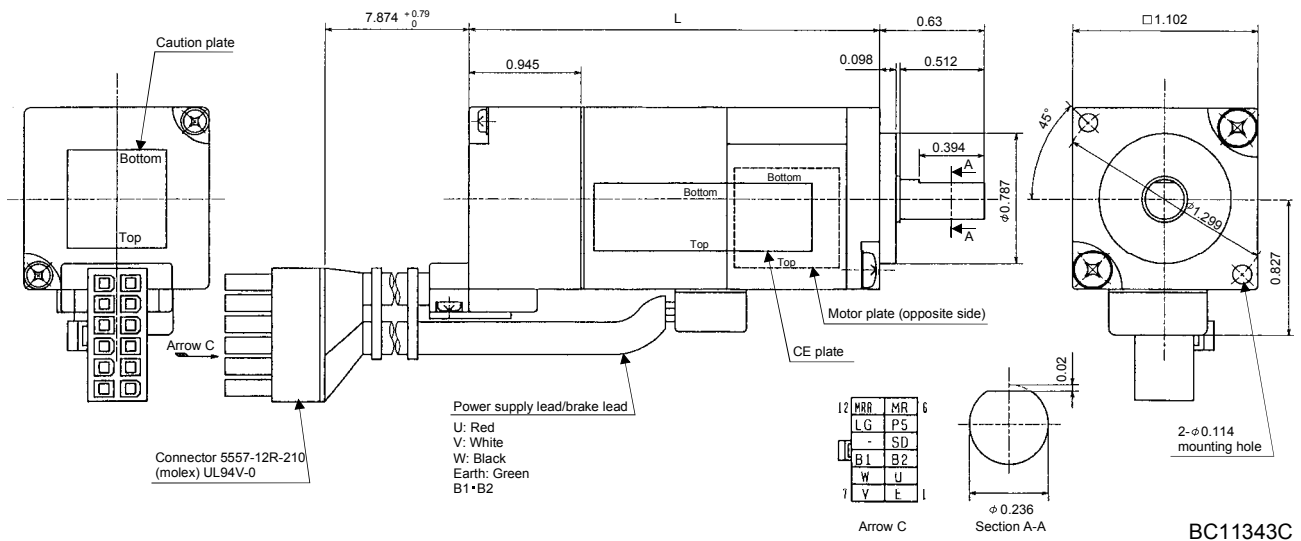

7. OUTLINE DIMENSION DRAWINGS

7.2.10 HA-LF series

Terminal box detail diagram

Motor Model	HA-LF30K2 HA-LF37K2 HA-LF30K24 HA-LF37K24	HA-LF45K24 HA-LF55K24
Motor power supply lead size	0.0124in ² (AWG8) × 2 parallel	0.0341in ² (AWG4) × 2 parallel
Motor power supply terminal block screw size	M8	M10
Terminal box dimensions (in)	LA	8.661
	LB	8.268
		10.472
		9.055

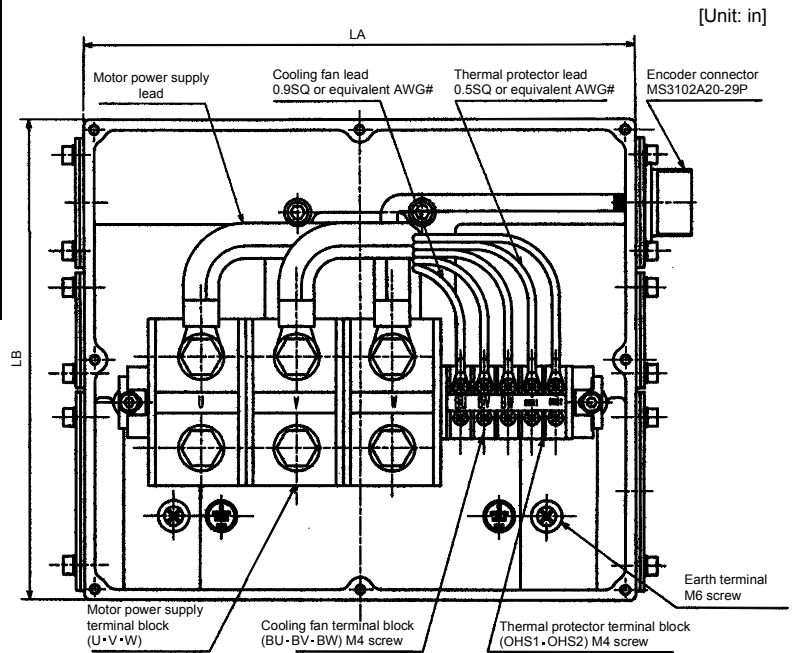

[Unit: in]

Model	Output [kW]	Inertia Moment WK ² [oz · in ²]	Mass [lb]
HA-LF30K24	30	3007.095	352.739

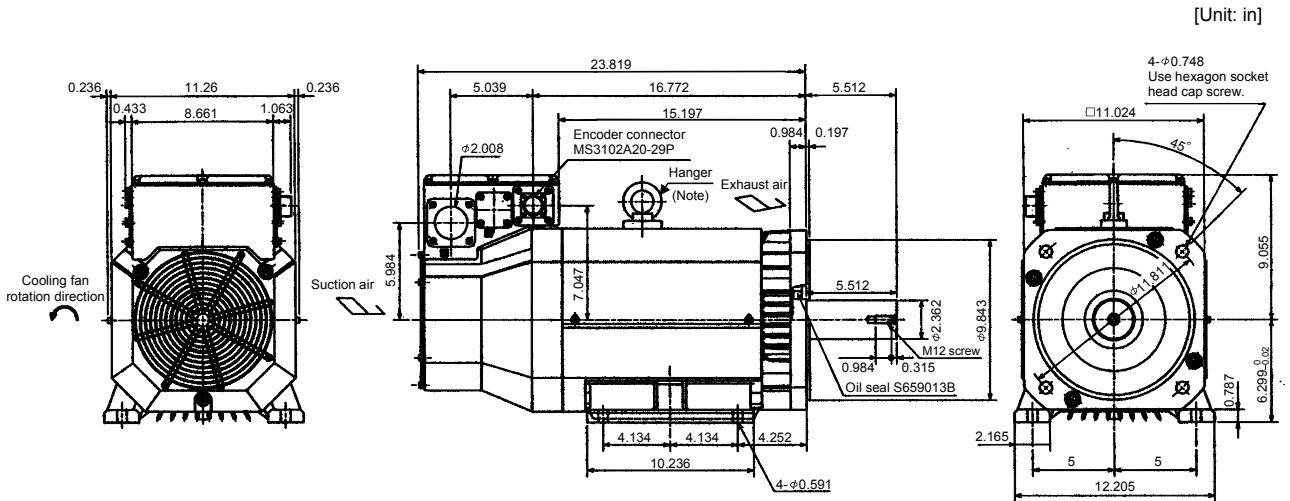

[Unit: in]

Note: When the motor is used without the hanger, plug the threaded hole with a bolt of M16×20mm or less.

BC10833

7. OUTLINE DIMENSION DRAWINGS

Model	Output [kW]	Inertia Moment WK^2 [oz · in ²]	Mass [lb]
HA-LF37K24	37	3553.84	396.832

[Unit: in]

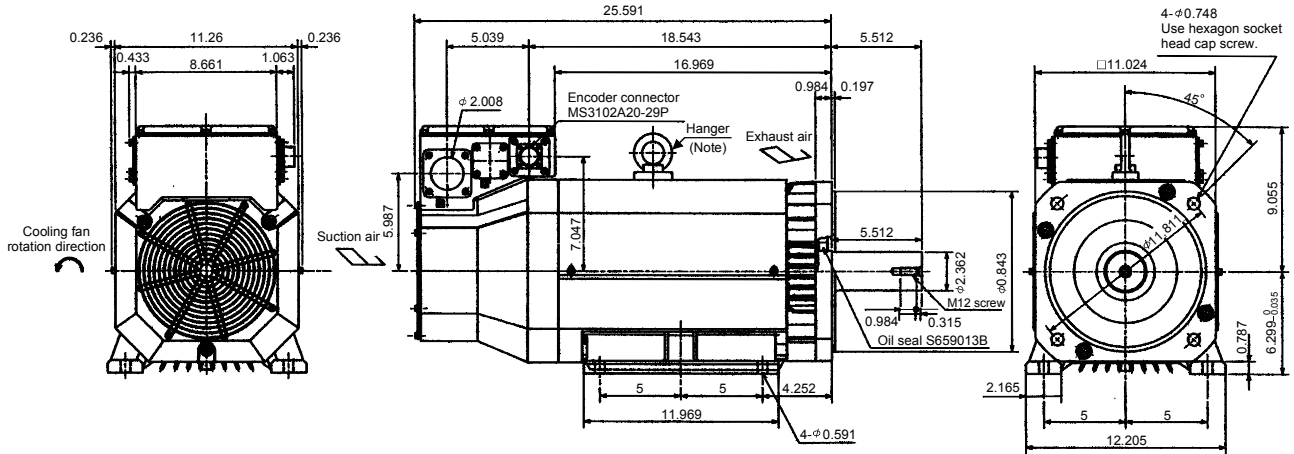

Note: When the motor is used without the hanger, plug the threaded hole with a bolt of M16×20mm or less.

BC10788C

Model	Output [kW]	Inertia Moment WK^2 [oz · in ²]	Mass [lb]
HA-LF45K24	45	5904.841	507.063

[Unit: in]

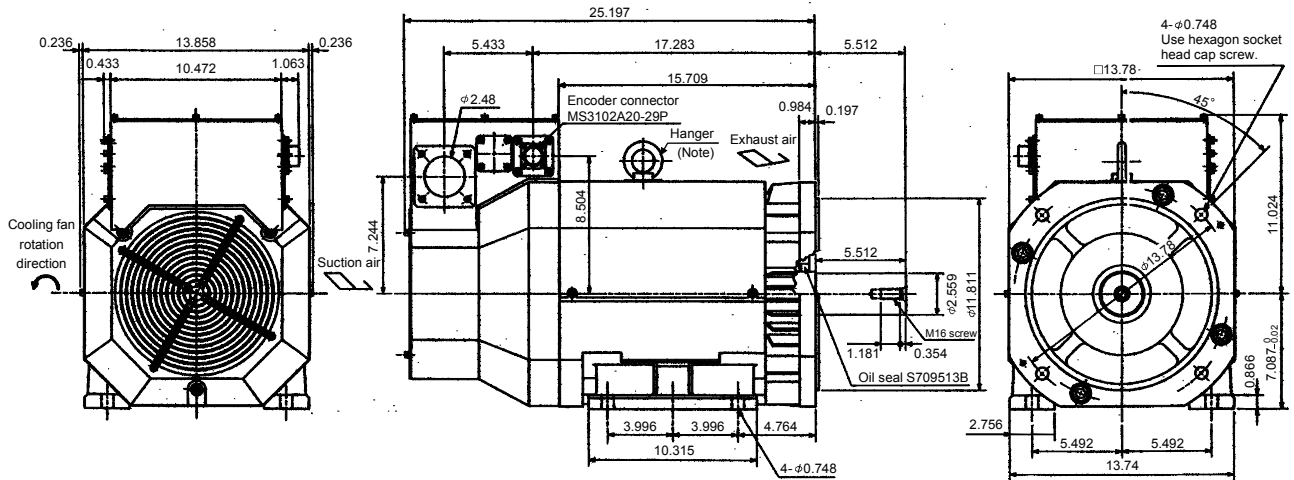

Note: When the motor is used without the hanger, plug the threaded hole with a bolt of M16×20mm or less.

BC11107A

7. OUTLINE DIMENSION DRAWINGS

Model	Output [kW]	Inertia Moment WK^2 [oz · in ²]	Mass [lb]
HA-LF55K24	55	7162.354	551.155

[Unit: in]

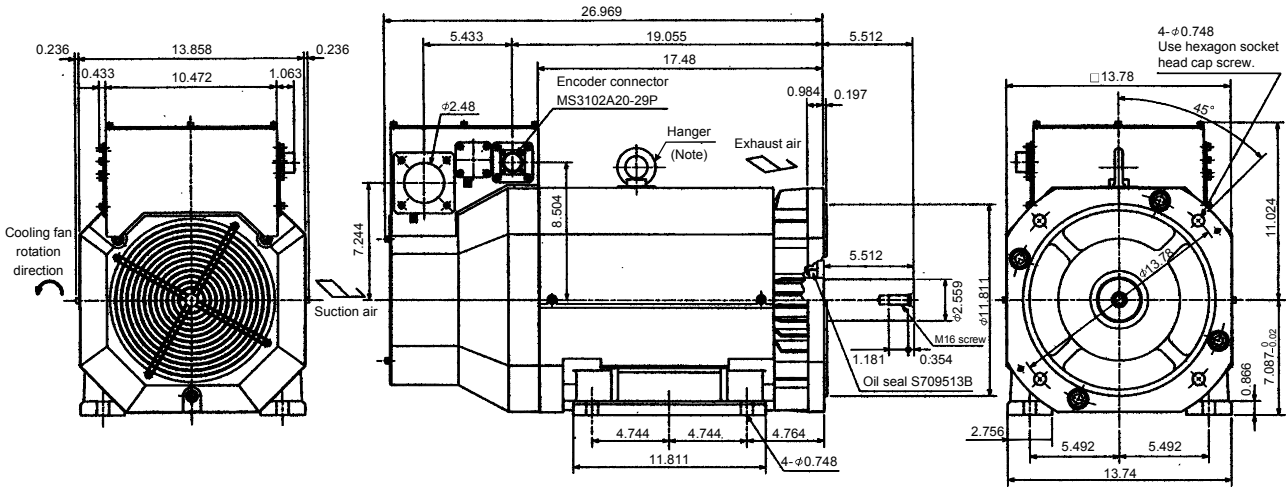

BC10522F

Model	Output [kW]	Inertia Moment WK^2 [oz · in ²]	Mass [lb]
HA-LF30K2	30	3007.095	352.739

[Unit: in]

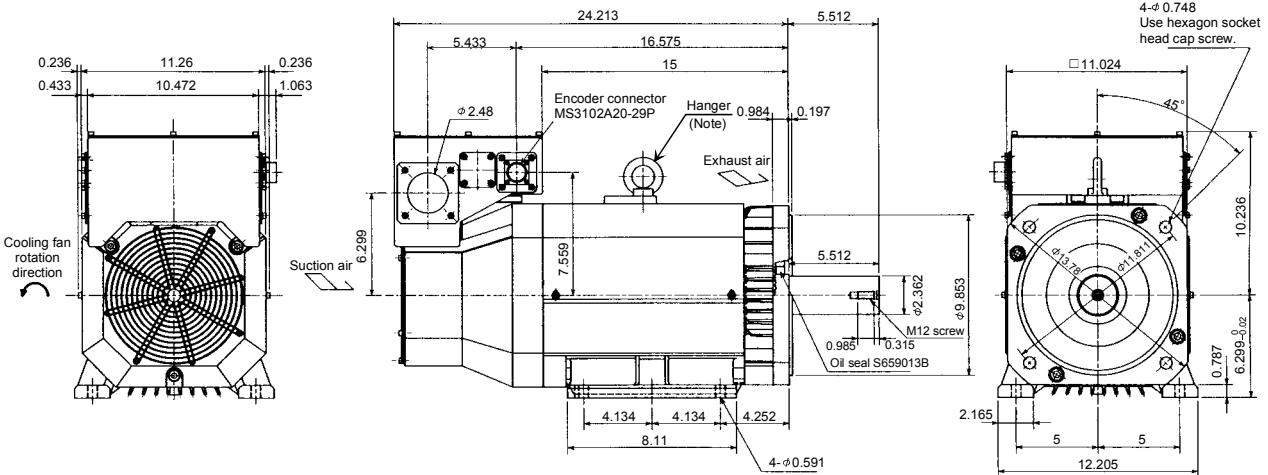

BC12180*

7. OUTLINE DIMENSION DRAWINGS

Model	Output [kW]	Inertia Moment WK ² [oz · in ²]	Mass [lb]
HA-LF37K2	37	3553.8	396.8

[Unit: in]

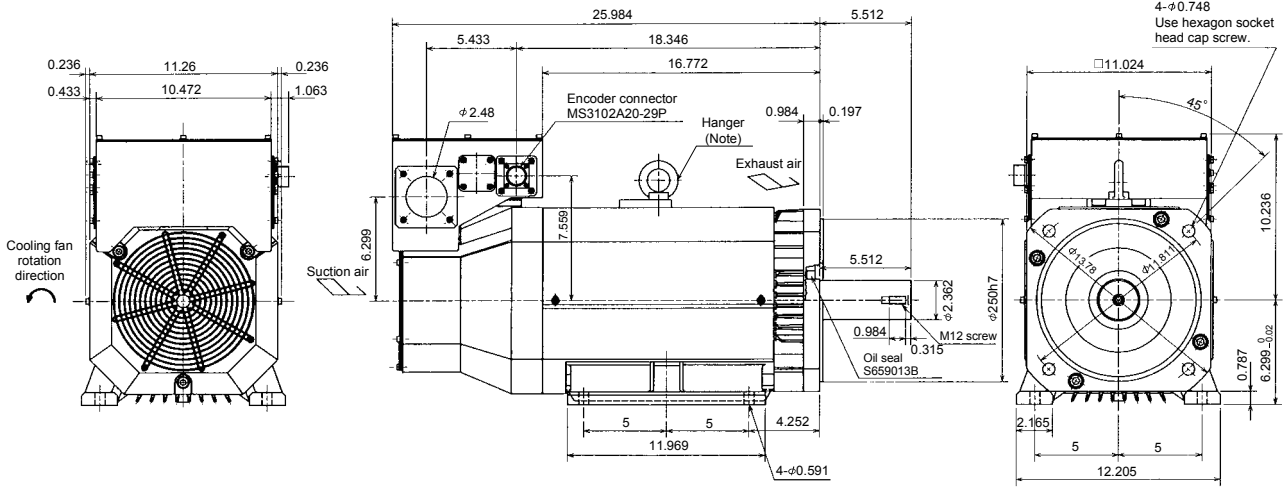

Note: When the motor is used without the hanger, plug the threaded hole with a bolt of M16 × 20mm or less.

BC12181*

7. OUTLINE DIMENSION DRAWINGS

7.2.11 HC-MFS • HC-KFS series

(1) Standard (without electromagnetic brake, without reduction gear)

Model	Output [W]	Variable Dimensions [in]		Inertia Moment WK ² [oz • in ²]	Mass [lb]
		L	KL		
HC-MFS053	50	3.21	1.16	0.10	0.9
HC-MFS13	100	3.80	0.18	0.16	1.2
HC-KFS053	50	3.21	0.12	0.29	0.9
HC-KFS13	100	3.80	1.75	0.46	1.2

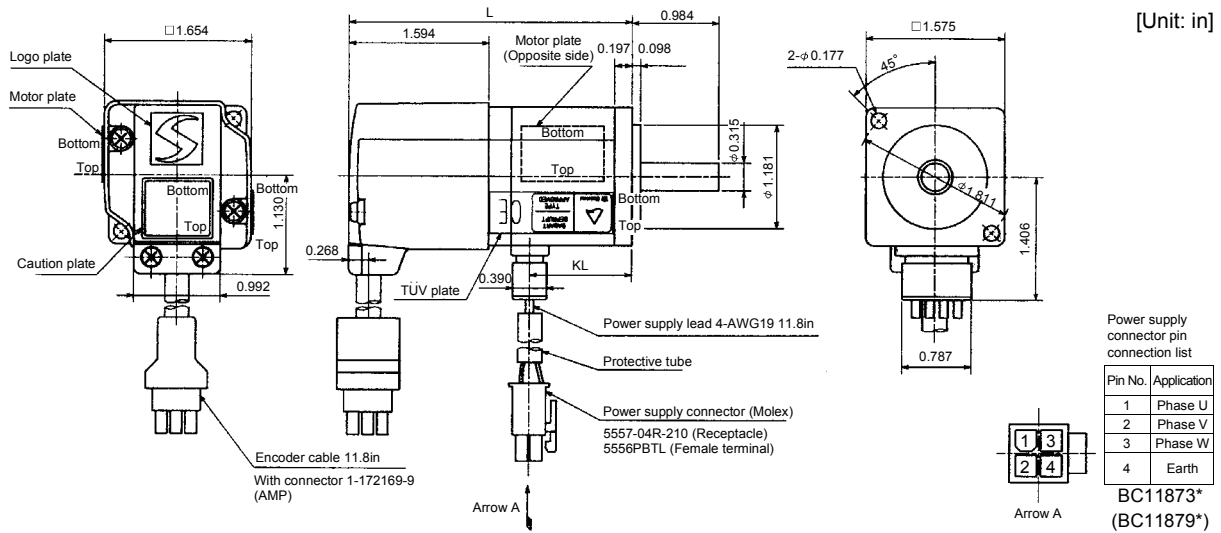

Model	Output [W]	Variable Dimensions [in]		Inertia Moment WK ² [oz • in ²]	Mass [lb]
		L	KL		
HC-MFS23	200	3.92	1.93	0.48	2.2
HC-MFS43	400	4.90	0.06	0.78	3.2
HC-KFS23	200	3.92	1.93	2.30	2.2
HC-KFS43	400	4.90	0.06	3.66	3.2

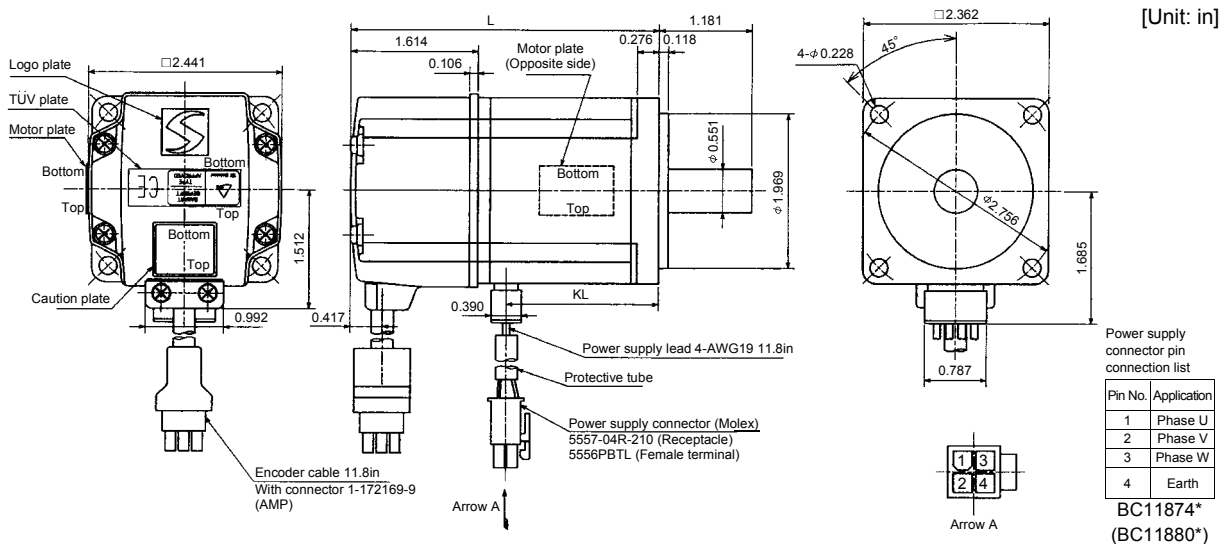

7. OUTLINE DIMENSION DRAWINGS

Model	Output [W]	Inertia Moment WK^2 [oz · in ²]	Mass [lb]
HC-MFS73	750	3.28	6.6
HC-KFS73	750	8.256	6.6

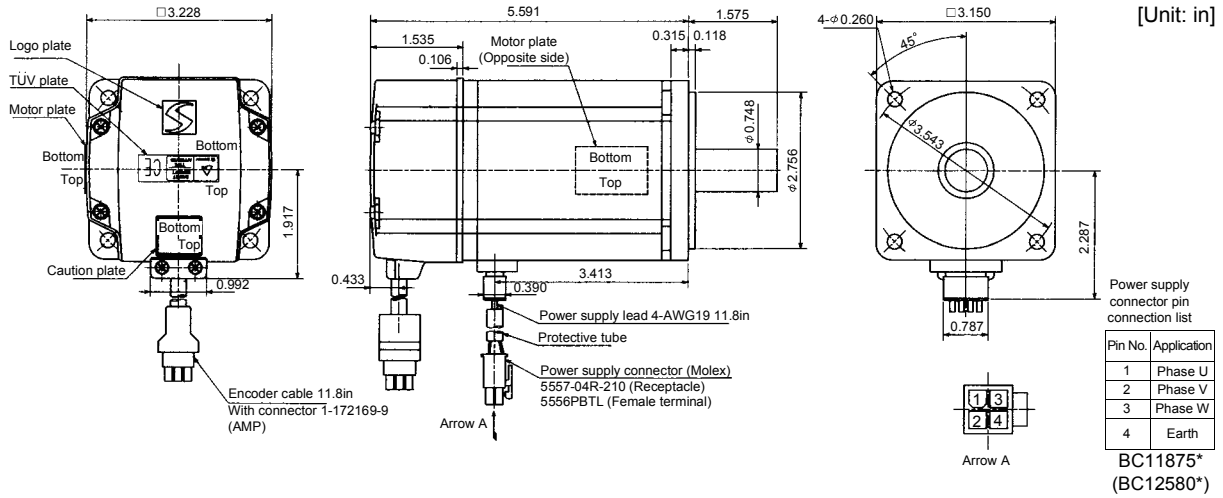

(2) With electromagnetic brake

Model	Output [W]	Variable Dimensions [in]		Brake static friction torque [oz · in]	Inertia Moment WK^2 [oz · in ²]	Mass [lb]
		L	KL			
HC-MFS053B	50	4.31	1.16	45.32	0.12	1.7
HC-MFS13B	100	4.90	1.75	45.32	0.18	2.0
HC-KFS053B	50	4.31	1.16	45.32	0.31	1.7
HC-KFS13B	100	4.90	1.75	45.32	0.48	2.0

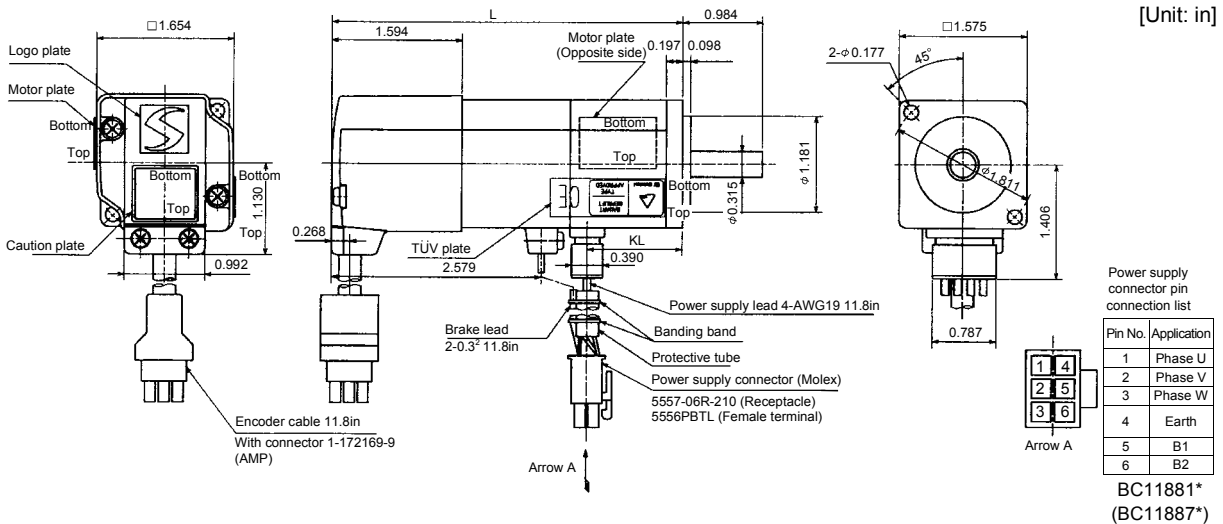

7. OUTLINE DIMENSION DRAWINGS

Model	Output [W]	Variable Dimensions [in]		Brake static friction torque [oz · in]	Inertia Moment WK^2 [oz · in ²]	Mass [lb]
		L	KL			
HC-MFS23B	200	5.18	1.93	184	0.74	3.5
HC-MFS43B	400	6.16	2.84	184	1.04	4.6
HC-KFS23B	200	5.18	1.93	184	1.694	3.5
HC-KFS43B	400	6.16	2.84	184	2.788	4.6

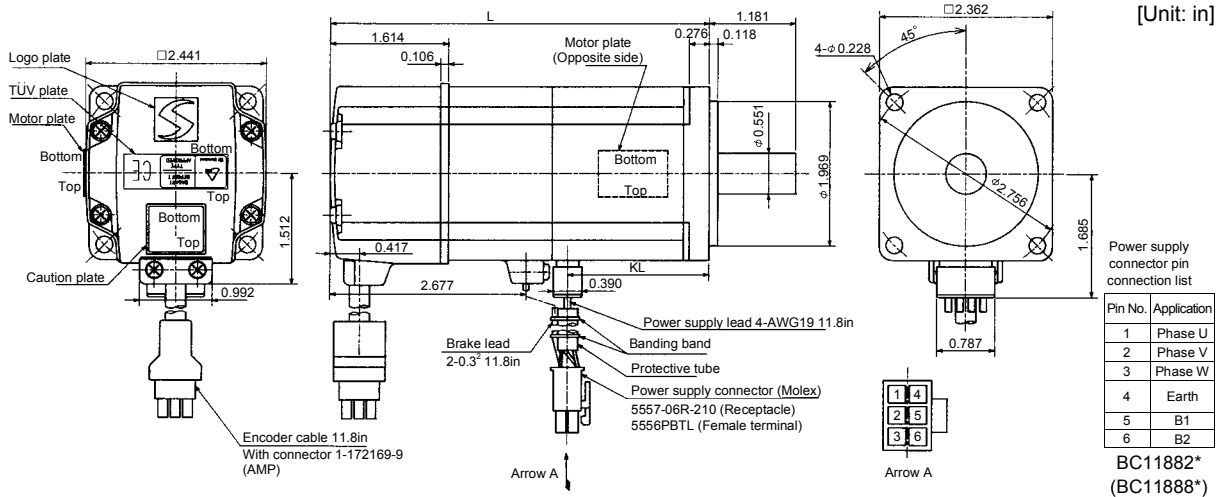

Model	Output [W]	Brake static friction torque [oz · in]	Inertia Moment WK^2 [oz · in ²]	Mass [lb]
HC-MFS73B	750	340	3.96	8.8
HC-KFS73B	750	340	8.94	8.8

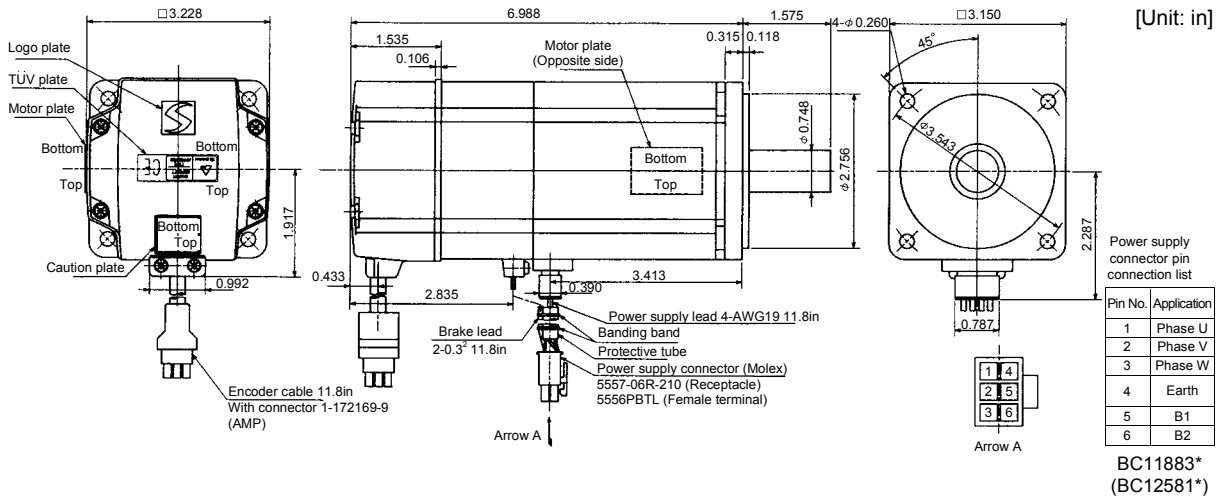

7. OUTLINE DIMENSION DRAWINGS

(3) With reduction gear for general industrial machine

The outer frame of the reduction gear is a material surface such as casting. Its actual dimensions may be 0.039 to 0.118 in larger than the drawing dimensions. Design the machine side with allowances.

(a) Without electromagnetic brake

Model	Output [W]	Variable Dimensions [in]		Reduction Gear Model	Reduction Ratio (Actual Reduction Ratio)	Inertia Moment WK^2 [oz · in ²]	Backlash	Mass [lb]
		L	KL					
HC-MFS053G1	50	4.96	2.91	K6505	1/5(9/44)	0.30	60min. max.	3.1
HC-MFS053G1	50	5.669	3.62	K6512	1/12(49/576)	0.42	60min. max.	4.0
HC-MFS053G1	50	5.669	3.62	K6520	1/20(25/484)	0.32	60min. max.	4.0
HC-KFS053G1	50	4.96	2.91	K6505	1/5(9/44)	0.49	60min. max.	3.1
HC-KFS053G1	50	5.669	3.62	K6512	1/12(49/576)	0.61	60min. max.	4.0
HC-KFS053G1	50	5.669	3.62	K6520	1/20(25/484)	0.51	60min. max.	4.0

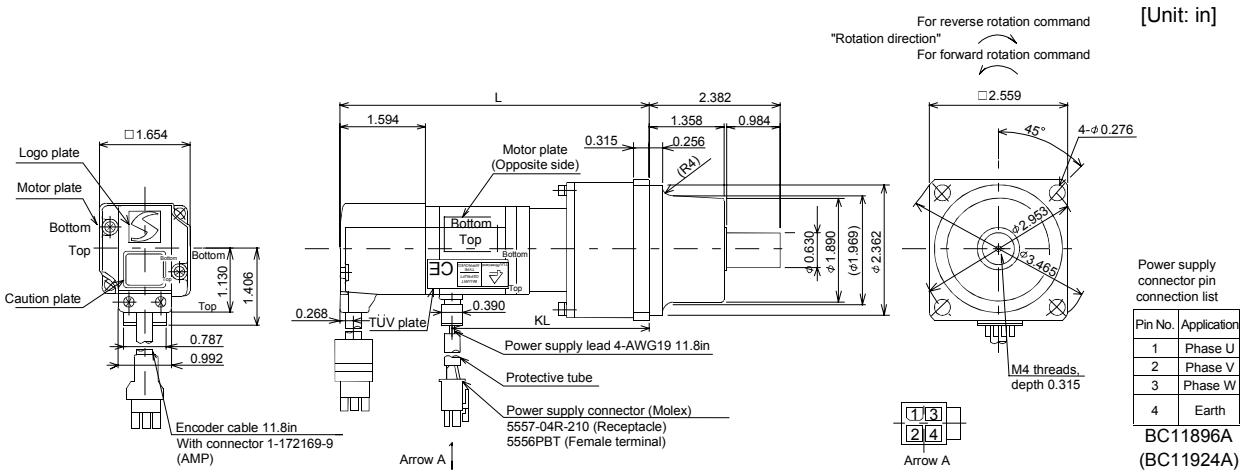

Model	Output [W]	Variable Dimensions [in]		Reduction Gear Model	Reduction Ratio (Actual Reduction Ratio)	Inertia Moment WK^2 [oz · in ²]	Backlash	Mass [lb]
		L	KL					
HC-MFS13G1	100	5.551	3.5	K6505	1/5(9/44)	0.36	60min. max.	3.31
HC-MFS13G1	100	6.26	4.21	K6512	1/12(49/576)	0.48	60min. max.	4.19
HC-MFS13G1	100	6.26	4.21	K6520	1/20(25/484)	0.38	60min. max.	4.19
HC-KFS13G1	100	5.551	3.5	K6505	1/5(9/44)	0.66	60min. max.	3.31
HC-KFS13G1	100	6.26	4.21	K6512	1/12(49/576)	0.78	60min. max.	4.19
HC-KFS13G1	100	6.26	4.21	K6520	1/20(25/484)	0.68	60min. max.	4.19

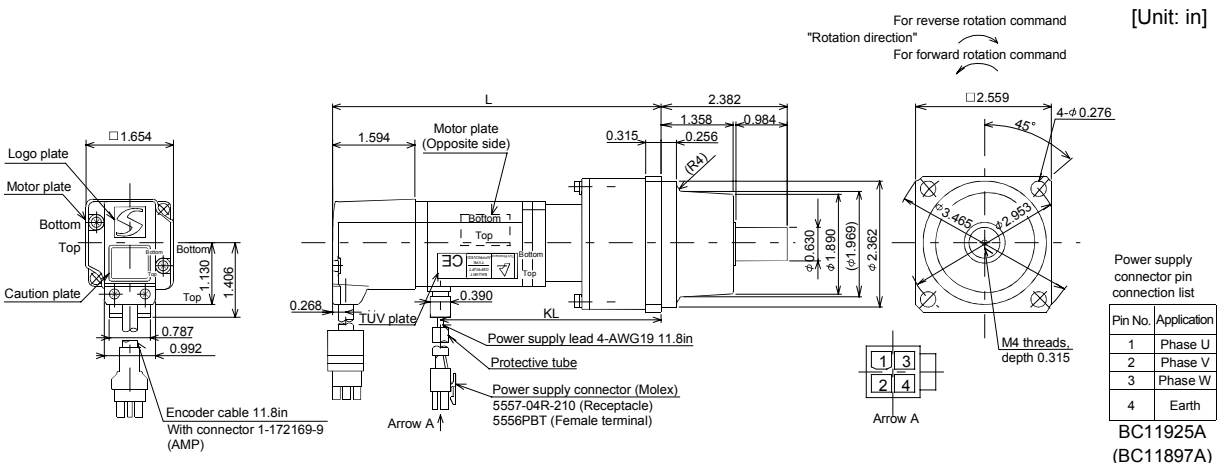

7. OUTLINE DIMENSION DRAWINGS

Model	Output [W]	Variable Dimensions [in]		Reduction Gear Model	Reduction Ratio (Actual Reduction Ratio)	Inertia Moment WK^2 [oz · in ²]	Mass [lb]
		L	KL				
HC-MFS23G1	200	6.02	4.04	K9005	1/5(19/96)	1.36	7.3
HC-MFS23G1	200	6.81	4.83	K9012	1/12(25/288)	1.60	8.6
HC-MFS23G1	200	6.81	4.83	K9020	1/20(253/5000)	1.45	8.6
HC-KFS23G1	200	6.02	4.04	K9005	1/5(19/96)	2.296	7.3
HC-KFS23G1	200	6.81	4.83	K9012	1/12(25/288)	2.569	8.6
HC-KFS23G1	200	6.81	4.83	K9020	1/20(253/5000)	2.406	8.6

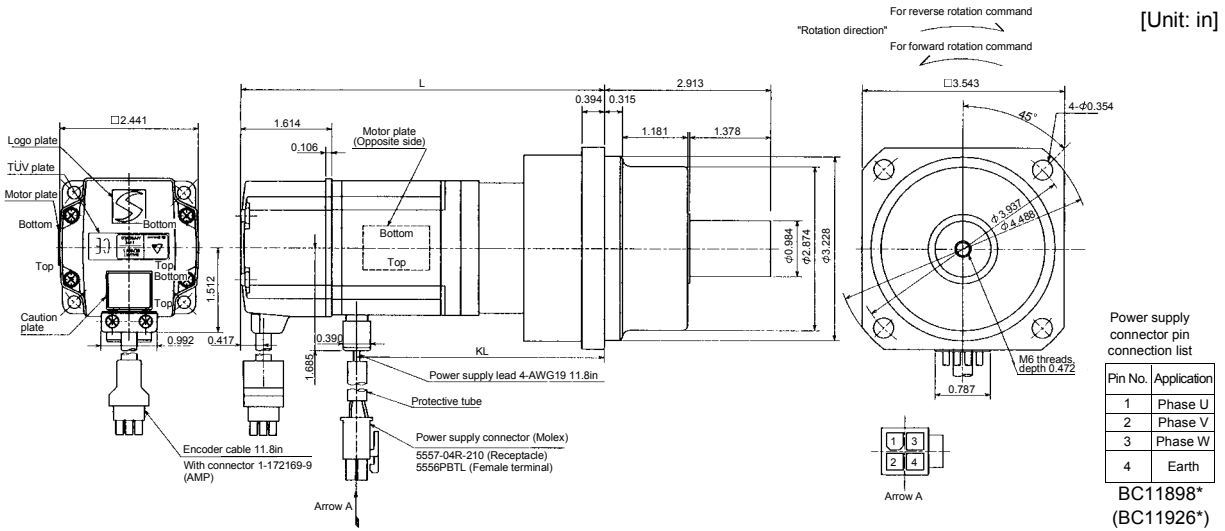

Model	Output [W]	Variable Dimensions [in]		Reduction Gear Model	Reduction Ratio (Actual Reduction Ratio)	Inertia Moment WK^2 [oz · in ²]	Mass [lb]
		L	KL				
HC-MFS43G1	400	7.01	4.95	K9005	1/5(19/96)	1.62	8.4
HC-MFS43G1	400	7.80	5.73	K9012	1/12(25/288)	1.85	9.7
HC-KFS43G1	400	7.01	4.95	K9005	1/5(19/96)	3.335	8.4
HC-KFS43G1	400	7.80	5.73	K9012	1/12(25/288)	3.609	9.7

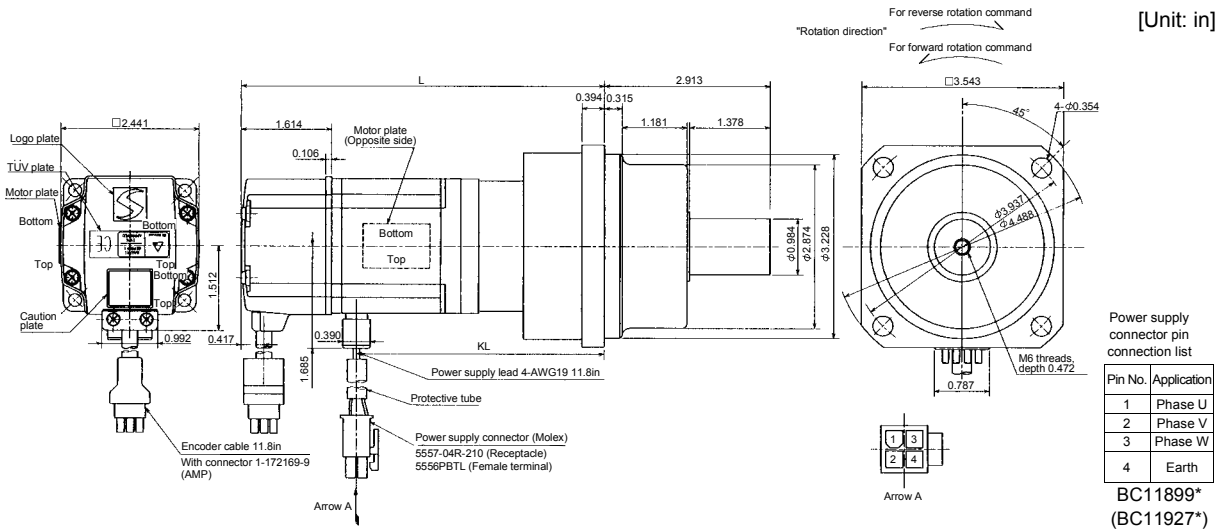

7. OUTLINE DIMENSION DRAWINGS

Model	Output [W]	Reduction Gear Model	Reduction Ratio		Inertia Moment WK ² [oz · in ²]	Backlash	Mass [lb]
			Normal Reduction ratio	Actual Reduction Ratio			
HC-MFS43G1	400	K10020	1/20	253/5000	3.57	60min. max.	12.13
HC-MFS73G1	750	K10005	1/5	1/5	5.58	60min. max.	13.67
HC-MFS73G1	750	K10012	1/12	525/6048	9.22	60min. max.	16.09
HC-MFS73G1	750	K12020	1/20	625/12544	9.57	60min. max.	22.27

Model	Output [W]	Variable Dimensions [in]																						
		D	LH	LK	LT	H	LA	LB	LC	LD	LE	LF	LG	LM	LN	LP	L	LR	KL	LZ	Q	S	P	R
HC-MFS43G1	400	2.362	1.50	1.61	0.42	1.69	4.53	3.74	5.20	3.94	0.39	2.87	0.39	0.512	0.63	3.39	7.933	3.54	5.87	0.35	1.97	1.26	M8	0.63
HC-MFS73G1	750	3.15	1.89	1.54	0.43	2.29	4.53	3.74	5.20	3.94	0.39	2.87	0.39	0.512	0.63	3.39	8.15	3.54	5.97	0.35	1.97	1.26	M8	0.63
HC-MFS73G1	750	3.15	1.89	1.54	0.43	2.29	4.53	3.74	5.20	3.94	0.39	2.87	0.39	0.512	0.63	3.39	9.016	3.54	6.84	0.35	1.97	1.26	M8	0.63
HC-MFS73G1	750	3.15	1.89	1.54	0.43	2.29	5.51	4.53	6.38	4.72	0.47	3.54	0.59	0.512	0.787	4.09	9.528	4.17	7.35	0.55	2.36	1.57	M10	0.79

Model	Output [W]	Reduction Gear Model	Reduction Ratio		Inertia Moment WK ² [oz · in ²]	Backlash	Mass [lb]
			Normal Reduction ratio	Actual Reduction Ratio			
HC-KFS43G1	400	K10020	1/20	253/5000	5.303	60min. max.	12.13
HC-KFS73G1	750	K10005	1/5	1/5	10.55	60min. max.	13.67
HC-KFS73G1	750	K10012	1/12	525/6048	14.19	60min. max.	16.09
HC-KFS73G1	750	K12020	1/20	625/12544	14.54	60min. max.	22.27

Model	Output [W]	Variable Dimensions [in]																						
		D	LH	LK	LT	H	LA	LB	LC	LD	LE	LF	LG	LM	LN	LP	L	LR	KL	LZ	Q	S	P	R
HC-KFS43G1	400	2.362	1.50	1.61	0.42	1.69	4.53	3.74	5.20	3.94	0.39	2.87	0.39	0.512	0.63	3.39	7.933	3.54	5.87	0.35	1.97	1.26	M8	0.63
HC-KFS73G1	750	3.15	1.89	1.54	0.43	2.29	4.53	3.74	5.20	3.94	0.39	2.87	0.39	0.512	0.63	3.39	8.15	3.54	5.97	0.35	1.97	1.26	M8	0.63
HC-KFS73G1	750	3.15	1.89	1.54	0.43	2.29	4.53	3.74	5.20	3.94	0.39	2.87	0.39	0.512	0.63	3.39	9.016	3.54	6.84	0.35	1.97	1.26	M8	0.63
HC-KFS73G1	750	3.15	1.89	1.54	0.43	2.29	5.51	4.53	6.38	4.72	0.47	3.54	0.59	0.512	0.787	4.09	9.528	4.17	7.35	0.55	2.36	1.57	M10	0.79

[Unit: in]

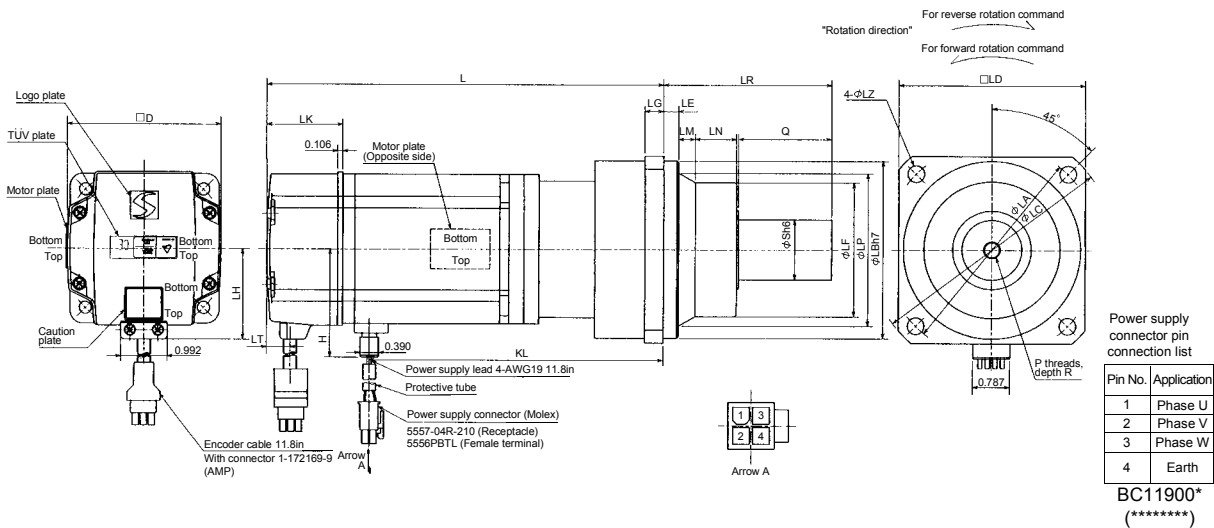

7. OUTLINE DIMENSION DRAWINGS

(b) With electromagnetic brake

Model	Output [W]	Variable Dimensions [in]		Brake static friction torque [oz · in]	Reduction Gear Model	Reduction Ratio (Actual Reduction Ratio)	Inertia Moment WK ² [oz · in ²]	Backlash	Mass [lb]
		L	KL						
HC-MFS053BG1	50	6.06	2.91	45	K6505	1/5(9/44)	0.32	60min. max.	4.0
HC-MFS053BG1	50	6.77	3.62	45	K6512	1/12(49/576)	0.44	60min. max.	4.9
HC-MFS053BG1	50	6.77	3.62	45	K6520	1/20(25/484)	0.34	60min. max.	4.9
HC-KFS053BG1	50	6.02	2.91	45	K6505	1/5(9/44)	0.51	60min. max.	4.0
HC-KFS053BG1	50	6.77	3.62	45	K6512	1/12(49/576)	0.63	60min. max.	4.9
HC-KFS053BG1	50	6.77	3.62	45	K6520	1/20(25/484)	0.53	60min. max.	4.9

[Unit: in]

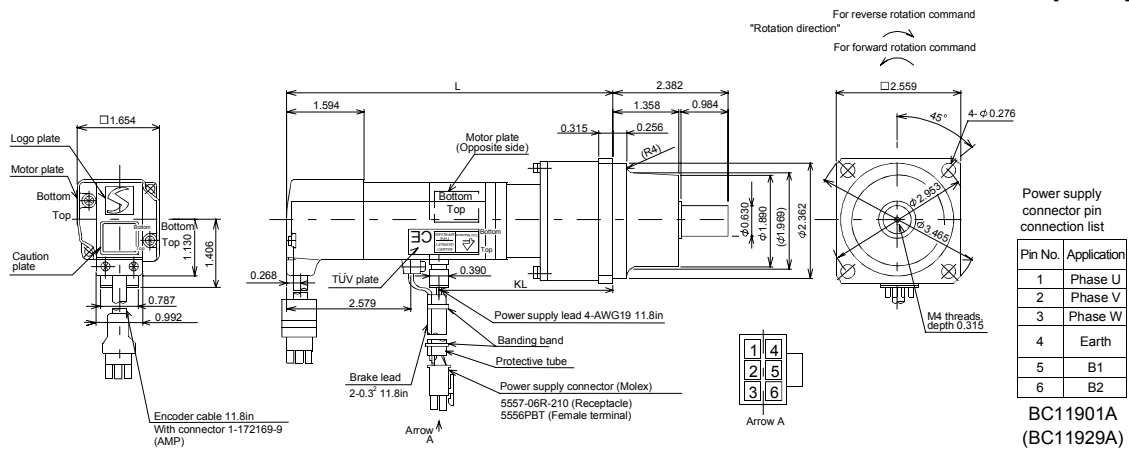

Model	Output [W]	Variable Dimensions (in)		Brake static friction torque [oz · in]	Reduction Gear Model	Reduction Ratio (Actual Reduction Ratio)	Inertia Moment WK ² [oz · in ²]	Backlash	Mass [lb]
		L	KL						
HC-MFS13BG1	100	6.65	3.43	45	K6505	1/5(9/44)	0.38	60min. max.	4.2
HC-MFS13BG1	100	7.36	4.21	45	K6512	1/12(49/576)	0.50	60min. max.	5.1
HC-MFS13BG1	100	7.36	4.21	45	K6520	1/20(25/484)	0.40	60min. max.	5.1
HC-KFS13BG1	100	6.65	3.43	45	K6505	1/5(9/44)	0.68	60min. max.	4.2
HC-KFS13BG1	100	7.36	4.21	45	K6512	1/12(49/576)	0.80	60min. max.	5.1
HC-KFS13BG1	100	7.36	4.21	45	K6520	1/20(25/484)	0.7	60min. max.	5.1

[Unit: in]

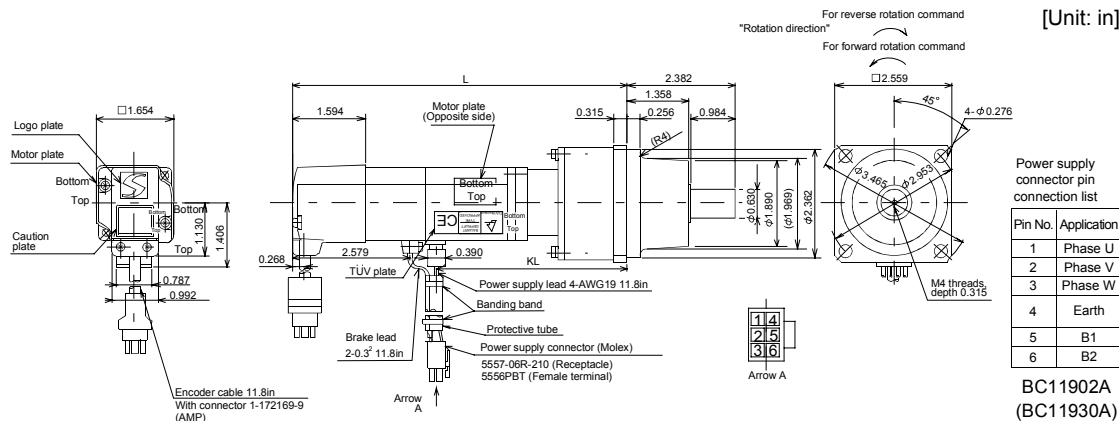

7. OUTLINE DIMENSION DRAWINGS

Model	Output [W]	Variable Dimensions [in]		Brake static friction torque [oz · in]	Reduction Gear Model	Reduction Ratio (Actual Reduction Ratio)	Inertia Moment WK ² [oz · in ²]	Mass [lb]
		L	KL					
HC-MFS23BG1	200	6.65	4.04	184	K9005	1/5(19/96)	1.58	8.6
HC-MFS23BG1	200	7.36	4.23	184	K9012	1/12(25/288)	1.82	9.9
HC-MFS23BG1	200	7.36	4.23	184	K9020	1/20(253/5000)	1.67	9.9
HC-KFS23BG1	200	6.65	4.04	184	K9005	1/5(19/96)	2.569	8.6
HC-KFS23BG1	200	7.36	4.23	184	K9012	1/12(25/288)	2.843	9.9
HC-KFS23BG1	200	7.36	4.23	184	K9020	1/20(253/5000)	2.679	9.9

[Unit: in]

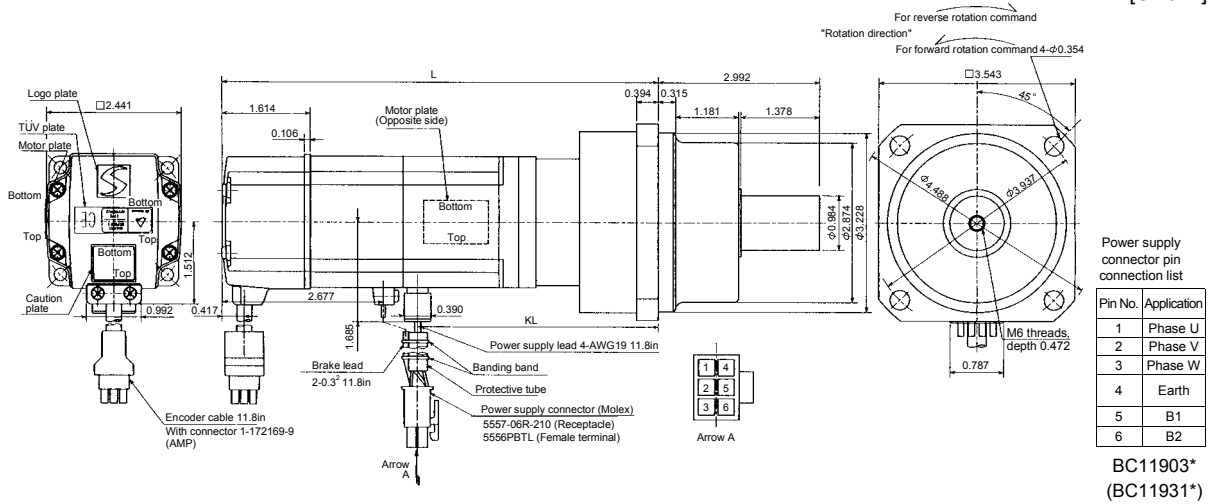

Model	Output [W]	Variable Dimensions [in]		Brake static friction torque [oz · in]	Reduction Gear Model	Reduction Ratio (Actual Reduction Ratio)	Inertia Moment WK ² [oz · in ²]	Mass [lb]
		L	KL					
HC-MFS43BG1	400	8.27	4.95	184	K9005	1/5(19/96)	1.88	9.7
HC-MFS43BG1	400	9.06	5.73	184	K9012	1/12(25/288)	2.12	11.0
HC-KFS43BG1	400	8.27	4.95	184	K9005	1/5(19/96)	3.609	9.7
HC-KFS43BG1	400	9.06	5.73	184	K9012	1/12(25/288)	3.882	11.0

[Unit: in]

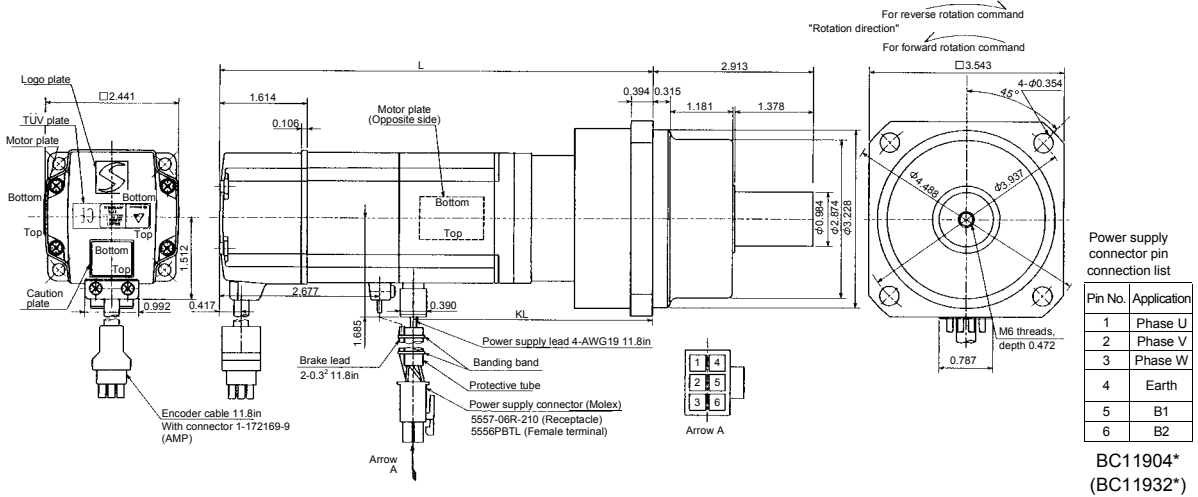

7. OUTLINE DIMENSION DRAWINGS

Model	Output [W]	Brake static friction torque [oz · in]	Reduction Gear Model	Reduction Ratio		Inertia Moment WK ² [oz · in ²]	Backlash	Mass [lb]
				Normal Reduction ratio	Actual Reduction Ratio			
HC-MFS43BG1	400	184	K10020	1/20	253/5000	3.83	60min. max.	13.4
HC-MFS73BG1	750	340	K10005	1/5	1/5	6.26	60min. max.	15.9
HC-MFS73BG1	750	340	K10012	1/12	525/6048	9.90	60min. max.	18.3
HC-MFS73BG1	750	340	K12020	1/20	625/12544	10.25	60min. max.	25.8

Model	Output [W]	Variable Dimensions [in]																							
		D	LH	LK	LT	LX	H	LA	LB	LC	LD	LE	LF	LG	LM	LN	LP	L	LR	KL	LZ	Q	S	P	R
HC-MFS43BG1	400	2.44	1.51	1.64	0.14	2.68	1.69	4.53	3.74	5.20	3.94	0.39	2.87	0.39	0.512	0.63	3.39	9.19	3.54	5.87	0.35	1.97	1.26	M8	0.63
HC-MFS73BG1	750	3.23	1.92	1.54	0.43	2.84	1.69	4.53	3.74	5.20	3.94	0.39	2.87	0.39	0.512	0.63	3.39	9.55	3.54	5.92	0.35	1.97	1.26	M8	0.63
HC-MFS73BG1	750	3.23	1.92	1.54	0.43	2.84	1.69	4.53	3.74	5.20	3.94	0.39	2.87	0.39	0.512	0.63	3.39	10.41	3.54	6.84	0.35	1.97	1.26	M8	0.63
HC-MFS73BG1	750	3.23	1.92	1.54	0.43	2.84	1.69	5.51	4.53	6.38	4.72	0.47	3.54	0.59	0.512	0.787	4.09	10.93	4.17	7.35	0.55	2.36	1.57	M10	0.79

Model	Output [W]	Brake static friction torque [oz · in]	Reduction Gear Model	Reduction Ratio		Inertia Moment WK ² [oz · in ²]	Backlash	Mass [lb]
				Normal Reduction ratio	Actual Reduction Ratio			
HC-KFS43BG1	400	184	K10020	1/20	253/5000	5.577	60min. max.	13.4
HC-KFS73BG1	750	340	K10005	1/5	1/5	11.24	60min. max.	15.9
HC-KFS73BG1	750	340	K10012	1/12	525/6048	14.88	60min. max.	18.3
HC-KFS73BG1	750	340	K12020	1/20	625/12544	15.23	60min. max.	25.8

Model	Output [W]	Variable Dimensions [in]																							
		D	LH	LK	LT	LX	H	LA	LB	LC	LD	LE	LF	LG	LM	LN	LP	L	LR	KL	LZ	Q	S	P	R
HC-KFS43BG1	400	2.44	1.51	1.64	0.14	2.68	1.69	4.53	3.74	5.20	3.94	0.39	2.87	0.39	0.512	0.63	3.39	9.19	3.54	5.87	0.35	1.97	1.26	M8	0.63
HC-KFS73BG1	750	3.23	1.92	1.54	0.43	2.84	1.69	4.53	3.74	5.20	3.94	0.39	2.87	0.39	0.512	0.63	3.39	9.55	3.54	5.92	0.35	1.97	1.26	M8	0.63
HC-KFS73BG1	750	3.23	1.92	1.54	0.43	2.84	1.69	4.53	3.74	5.20	3.94	0.39	2.87	0.39	0.512	0.63	3.39	10.41	3.54	6.84	0.35	1.97	1.26	M8	0.63
HC-KFS73BG1	750	3.23	1.92	1.54	0.43	2.84	1.69	5.51	4.53	6.38	4.72	0.47	3.54	0.59	0.512	0.787	4.09	10.93	4.17	7.35	0.55	2.36	1.57	M10	0.79

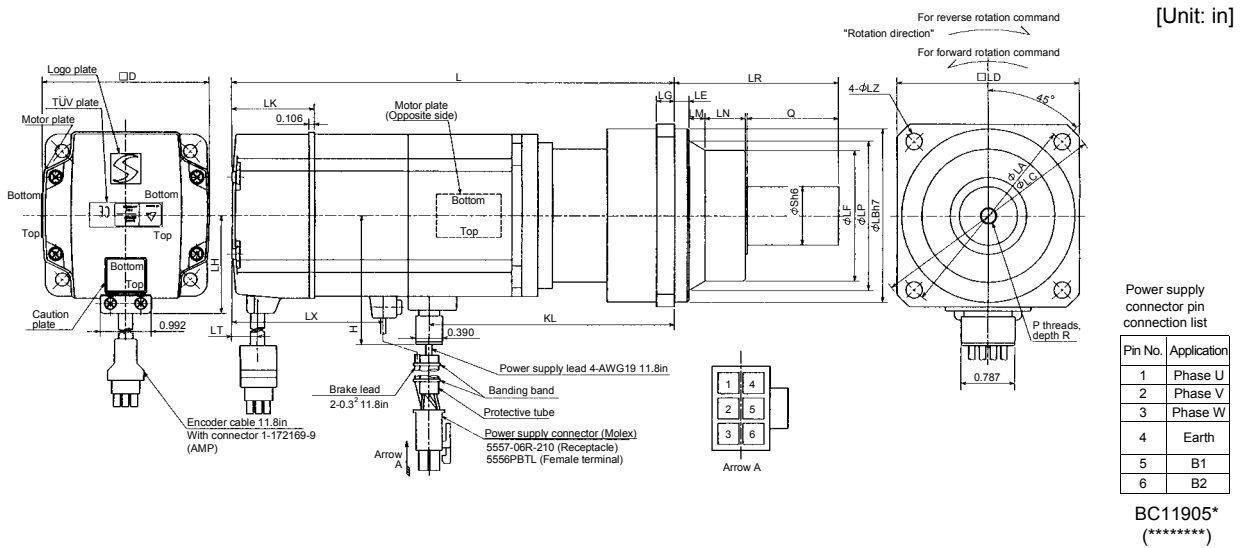

7. OUTLINE DIMENSION DRAWINGS

(4) With reduction gear for precision application

The outer frame of the reduction gear is a material surface such as casting. Its actual dimensions may be 0.039 to 0.118 in larger than the drawing dimensions. Design the machine side with allowances.

(a) Without electromagnetic brake

Model	Output [W]	Variable Dimensions [in]		Reduction Gear Model	Reduction Ratio	Inertia Moment WK ² [oz · in ²]	Backlash	Mass [lb]
		L	KL					
HC-MFS053G2	50	5.12	3.07	BK1-05B-A5MEKA	1/5	0.36	3 min. max.	3.1
HC-MFS053G2	50	5.75	3.70	BK1-09B-A5MEKA	1/9	0.33	3 min. max.	3.7
HC-MFS053G2	50	5.75	3.70	BK1-20B-A5MEKA	1/20	0.38	3 min. max.	4.0
HC-MFS053G2	50	5.75	3.70	BK1-29B-A5MEKA	1/29	0.31	3 min. max.	4.0
HC-KFS053G2	50	5.12	3.07	BK1-05B-A5MEKA	1/5	0.55	3 min. max.	3.1
HC-KFS053G2	50	5.75	3.70	BK1-09B-A5MEKA	1/9	0.52	3 min. max.	3.7
HC-KFS053G2	50	5.75	3.70	BK1-20B-A5MEKA	1/20	0.57	3 min. max.	4.0
HC-KFS053G2	50	5.75	3.70	BK1-29B-A5MEKA	1/29	0.50	3 min. max.	4.0

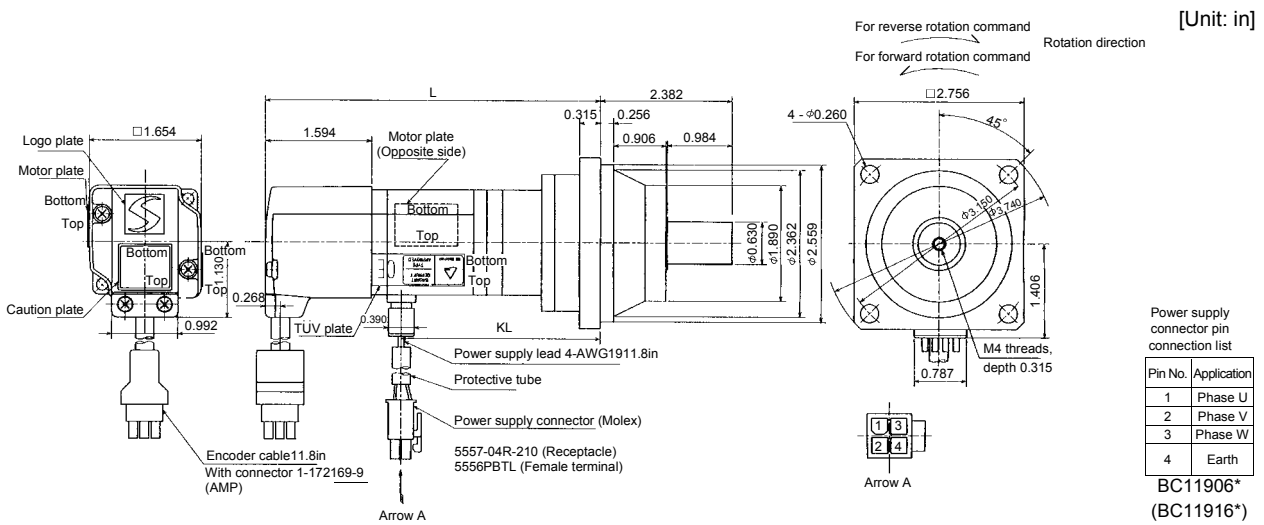

7. OUTLINE DIMENSION DRAWINGS

Model	Output [W]	Reduction Gear Model	Reduction Ratio	Inertia Moment Wk^2 [oz · in ²]	Backlash	Mass [lb]
HC-MFS13G2	100	BK1-05B-01MEKA	1/5	0.43	3 min. max.	3.3
HC-MFS13G2	100	BK1-09B-01MEKA	1/9	0.39	3 min. max.	4.0
HC-MFS13G2	100	BK2-20B-01MEKA	1/20	0.66	3 min. max.	6.6
HC-MFS13G2	100	BK2-29B-01MEKA	1/29	0.52	3 min. max.	6.6

Model	Output [W]	Variable Dimensions [in]																
		LA	LB	LC	LD	LE	LF	LG	LH	LK	L	LR	KL	LZ	Q	S	P	R
HC-MFS13G2	100	3.15	2.56	3.74	2.76	0.24	1.89	0.31	2.362	0.906	5.71	2.17	3.66	0.26	0.98	0.63	M4	0.31
HC-MFS13G2	100	3.15	2.56	3.74	2.76	0.24	1.89	0.31	2.362	0.906	6.34	2.17	4.29	0.26	0.98	0.63	M4	0.31
HC-MFS13G2	100	3.94	3.15	4.53	3.35	0.24	2.559	0.39	2.913	1.299	6.57	2.95	4.53	0.26	1.38	0.79	M5	0.39
HC-MFS13G2	100	3.94	3.15	4.53	3.35	0.24	2.559	0.39	2.913	1.299	6.57	2.95	4.53	0.26	1.38	0.79	M5	0.39

Model	Output [W]	Reduction Gear Model	Reduction Ratio	Inertia Moment Wk^2 [oz · in ²]	Backlash	Mass [lb]
HC-KFS13G2	100	BK1-05B-01MEKA	1/5	0.72	3 min. max.	3.3
HC-KFS13G2	100	BK1-09B-01MEKA	1/9	0.69	3 min. max.	4.0
HC-KFS13G2	100	BK2-20B-01MEKA	1/20	0.96	3 min. max.	6.6
HC-KFS13G2	100	BK2-29B-01MEKA	1/29	0.82	3 min. max.	6.6

Model	Output [W]	Variable Dimensions [in]																
		LA	LB	LC	LD	LE	LF	LG	LH	LK	L	LR	KL	LZ	Q	S	P	R
HC-KFS13G2	100	3.15	2.56	3.74	2.76	0.24	1.89	0.31	2.362	0.906	5.71	2.17	3.66	0.26	0.98	0.63	M4	0.31
HC-KFS13G2	100	3.15	2.56	3.74	2.76	0.24	1.89	0.31	2.362	0.906	6.34	2.17	4.29	0.26	0.98	0.63	M4	0.31
HC-KFS13G2	100	3.94	3.15	4.53	3.35	0.24	2.559	0.39	2.913	1.299	6.57	2.95	4.53	0.26	1.38	0.79	M5	0.39
HC-KFS13G2	100	3.94	3.15	4.53	3.35	0.24	2.559	0.39	2.913	1.299	6.57	2.95	4.53	0.26	1.38	0.79	M5	0.39

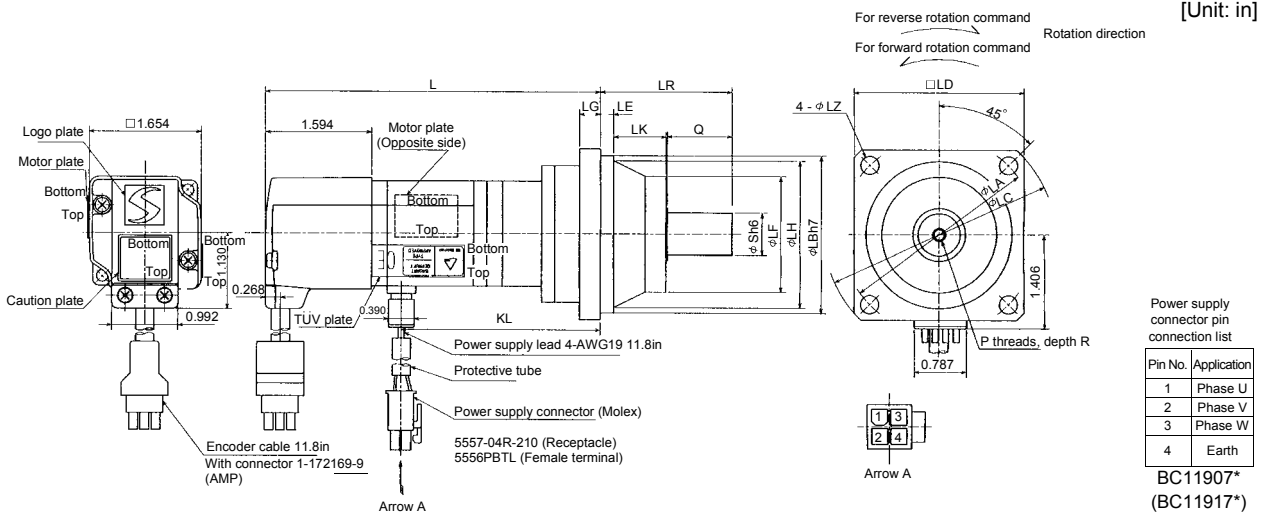

7. OUTLINE DIMENSION DRAWINGS

Model	Output [W]	Reduction Gear Model	Reduction Ratio	Inertia Moment WK^2 [oz · in ²]	Mass [lb]
HC-MFS23G2	200	BK1-05B-02MEKA	1/5	1.04	4.6
HC-MFS23G2	200	BK2-09B-02MEKA	1/9	1.14	7.7
HC-MFS23G2	200	BK3-20B-02MEKA	1/20	1.95	11.0
HC-MFS23G2	200	BK3-29B-02MEKA	1/29	1.51	11.0

Model	Output [W]	Variable Dimensions [in]																
		LA	LB	LC	LD	LE	LF	LG	LH	LK	L	LR	KL	LZ	Q	S	P	R
HC-MFS23G2	200	3.15	2.56	3.74	2.76	0.24	1.89	0.31	2.362	0.906	6.18	2.17	4.20	0.26	0.98	0.63	M4	0.31
HC-MFS23G2	200	3.94	3.15	4.53	3.35	0.24	2.559	0.39	2.913	1.299	6.89	2.95	4.91	0.26	1.38	0.79	M5	0.39
HC-MFS23G2	200	4.53	3.74	5.31	3.94	0.31	2.953	0.39	3.346	1.378	7.09	3.35	5.10	0.35	1.57	0.98	M6	0.47
HC-MFS23G2	200	4.53	3.74	5.31	3.94	0.31	2.953	0.39	3.346	1.378	7.09	3.35	5.10	0.35	1.57	0.98	M6	0.47

Model	Output [W]	Reduction Gear Model	Reduction Ratio	Inertia Moment WK^2 [oz · in ²]	Mass [lb]
HC-KFS23G2	200	BK1-05B-02MEKA	1/5	1.968	4.6
HC-KFS23G2	200	BK2-09B-02MEKA	1/9	2.078	7.7
HC-KFS23G2	200	BK3-20B-02MEKA	1/20	2.898	11.0
HC-KFS23G2	200	BK3-29B-02MEKA	1/29	2.460	11.0

Model	Output [W]	Variable Dimensions [in]																
		LA	LB	LC	LD	LE	LF	LG	LH	LK	L	LR	KL	LZ	Q	S	P	R
HC-KFS23G2	200	3.15	2.56	3.74	2.76	0.24	1.89	0.31	2.362	0.906	6.18	2.17	4.20	0.26	0.98	0.63	M4	0.31
HC-KFS23G2	200	3.94	3.15	4.53	3.35	0.24	2.559	0.39	2.913	1.299	6.89	2.95	4.91	0.26	1.38	0.79	M5	0.39
HC-KFS23G2	200	4.53	3.74	5.31	3.94	0.31	2.953	0.39	3.346	1.378	7.09	3.35	5.10	0.35	1.57	0.98	M6	0.47
HC-KFS23G2	200	4.53	3.74	5.31	3.94	0.31	2.953	0.39	3.346	1.378	7.09	3.35	5.10	0.35	1.57	0.98	M6	0.47

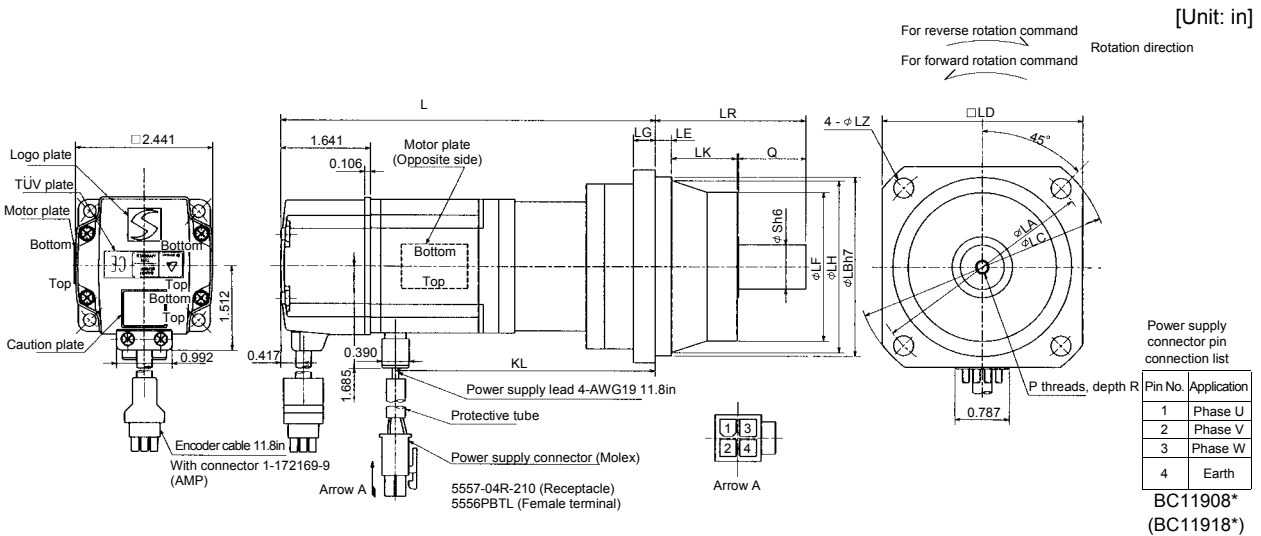

7. OUTLINE DIMENSION DRAWINGS

Model	Output [W]	Reduction Gear Model	Reduction Ratio	Inertia Moment WK^2 [oz · in ²]	Mass [lb]
HC-MFS43G2	400	BK2-05B-04MEKA	1/5	1.61	8.2
HC-MFS43G2	400	BK3-09B-04MEKA	1/9	1.77	11.7
HC-MFS43G2	400	BK4-20B-04MEKA	1/20	2.33	16.5
HC-MFS43G2	400	BK4-29B-04MEKA	1/29	1.85	16.5

Model	Output [W]	Variable Dimensions [in]																
		LA	LB	LC	LD	LE	LF	LG	LH	LK	L	LR	KL	LZ	Q	S	P	R
HC-MFS43G2	400	3.94	3.15	4.53	3.35	0.24	2.56	0.39	2.91	1.3	7.24	2.95	5.18	0.26	1.38	0.79	M5	0.39
HC-MFS43G2	400	4.53	3.74	5.31	3.94	0.31	2.95	0.39	3.35	1.38	8.07	3.35	6.01	0.35	1.58	0.98	M6	0.47
HC-MFS43G2	400	5.32	3.94	6.10	4.53	0.31	3.54	0.47	3.94	1.58	8.31	3.94	6.24	0.43	1.97	1.26	M8	0.63
HC-MFS43G2	400	5.32	4.33	6.10	4.53	0.31	3.54	0.47	3.94	1.58	8.31	3.94	6.24	0.43	1.26	1.26	M8	0.63

Model	Output [W]	Reduction Gear Model	Reduction Ratio	Inertia Moment WK^2 [oz · in ²]	Mass [lb]
HC-KFS43G2	400	BK2-05B-04MEKA	1/5	3.335	8.2
HC-KFS43G2	400	BK3-09B-04MEKA	1/9	3.499	11.7
HC-KFS43G2	400	BK4-20B-04MEKA	1/20	4.046	16.5
HC-KFS43G2	400	BK4-29B-04MEKA	1/29	3.609	16.5

Model	Output [W]	Variable Dimensions [in]																
		LA	LB	LC	LD	LE	LF	LG	LH	LK	L	LR	KL	LZ	Q	S	P	R
HC-KFS43G2	400	3.94	3.15	4.53	3.35	0.24	2.56	0.39	2.91	1.3	7.24	2.95	5.18	0.26	1.38	0.79	M5	0.39
HC-KFS43G2	400	4.53	3.74	5.31	3.94	0.31	2.95	0.39	3.35	1.38	8.07	3.35	6.01	0.35	1.58	0.98	M6	0.47
HC-KFS43G2	400	5.32	4.33	6.10	4.53	0.31	3.54	0.47	3.94	1.58	8.31	3.94	0.43	0.43	1.97	1.26	M8	0.63
HC-KFS43G2	400	5.32	4.33	6.10	4.53	0.31	3.54	0.47	3.94	1.58	8.31	3.94	0.43	0.43	1.26	1.26	M8	0.63

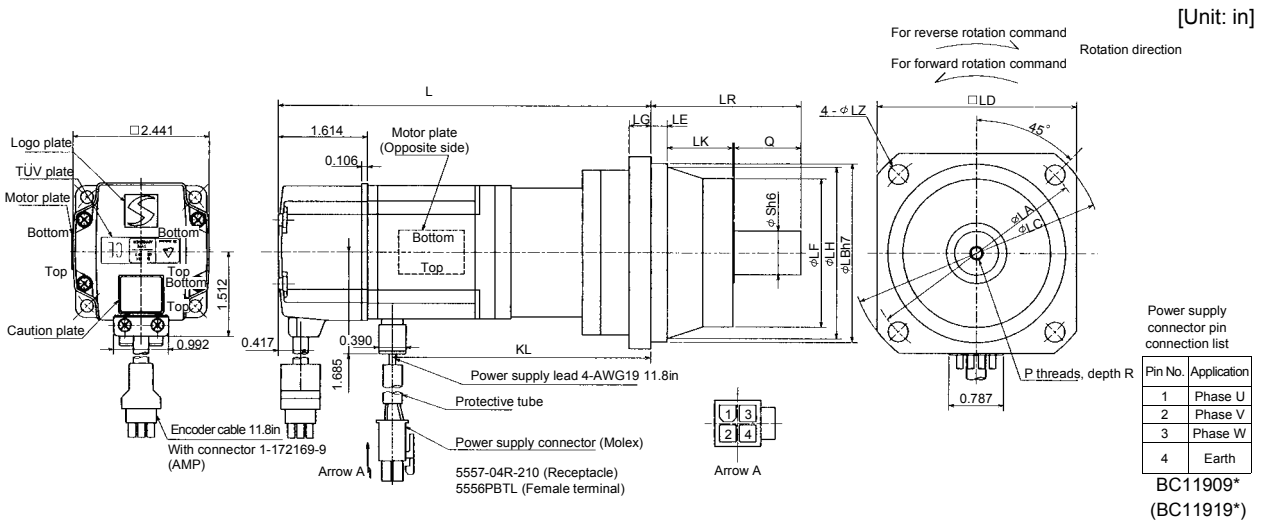

7. OUTLINE DIMENSION DRAWINGS

Model	Output [W]	Reduction Gear Model	Reduction Ratio	Inertia Moment WK^2 [oz · in ²]	Mass [lb]
HC-MFS73G2	750	BK3-05B-08MEKA	1/5	5.32	13.89
HC-MFS73G2	750	BK4-09B-08MEKA	1/9	5.36	18.96
HC-MFS73G2	750	BK5-20B-08MEKA	1/20	5.55	26.46
HC-MFS73G2	750	BK5-29B-08MEKA	1/29	4.97	26.46

Model	Output [W]	Variable Dimensions [in]																
		LA	LB	LC	LD	LE	LF	LG	LH	LK	L	LR	KL	LZ	Q	S	P	R
HC-MFS73G2	750	4.53	3.74	5.31	3.94	0.31	2.953	0.39	3.346	1.378	8.35	3.35	6.17	0.35	1.57	0.98	M6	0.47
HC-MFS73G2	750	5.31	4.33	6.10	4.53	0.31	3.543	0.47	3.937	1.575	9.45	3.94	7.27	0.43	1.97	1.26	M8	0.63
HC-MFS73G2	750	5.91	4.92	6.89	5.12	0.39	4.134	0.59	4.528	1.693	9.76	4.53	7.59	0.55	2.36	1.57	M10	0.79
HC-MFS73G2	750	5.91	4.92	6.89	5.12	0.39	4.134	0.59	4.528	1.693	9.76	4.53	7.59	0.55	2.36	1.57	M10	0.79

Model	Output [W]	Reduction Gear Model	Reduction Ratio	Inertia Moment WK^2 [oz · in ²]	Mass [lb]
HC-KFS73G2	750	BK3-05B-08MEKA	1/5	10.30	13.89
HC-KFS73G2	750	BK4-09B-08MEKA	1/9	10.33	18.96
HC-KFS73G2	750	BK5-20B-08MEKA	1/20	10.53	26.46
HC-KFS73G2	750	BK5-29B-08MEKA	1/29	9.95	26.46

Model	Output [W]	Variable Dimensions [in]																
		LA	LB	LC	LD	LE	LF	LG	LH	LK	L	LR	KL	LZ	Q	S	P	R
HC-KFS73G2	750	4.53	3.74	5.31	3.94	0.31	2.953	0.39	3.346	1.378	8.35	3.35	6.17	0.35	1.57	0.98	M6	0.47
HC-KFS73G2	750	5.31	4.33	6.10	4.53	0.31	3.543	0.47	3.937	1.575	9.45	3.94	7.27	0.43	1.97	1.26	M8	0.63
HC-KFS73G2	750	5.91	4.92	6.89	5.12	0.39	4.134	0.59	4.528	1.693	9.76	4.53	7.59	0.55	2.36	1.57	M10	0.79
HC-KFS73G2	750	5.91	4.92	6.89	5.12	0.39	4.134	0.59	4.528	1.693	9.76	4.53	7.59	0.55	2.36	1.57	M10	0.79

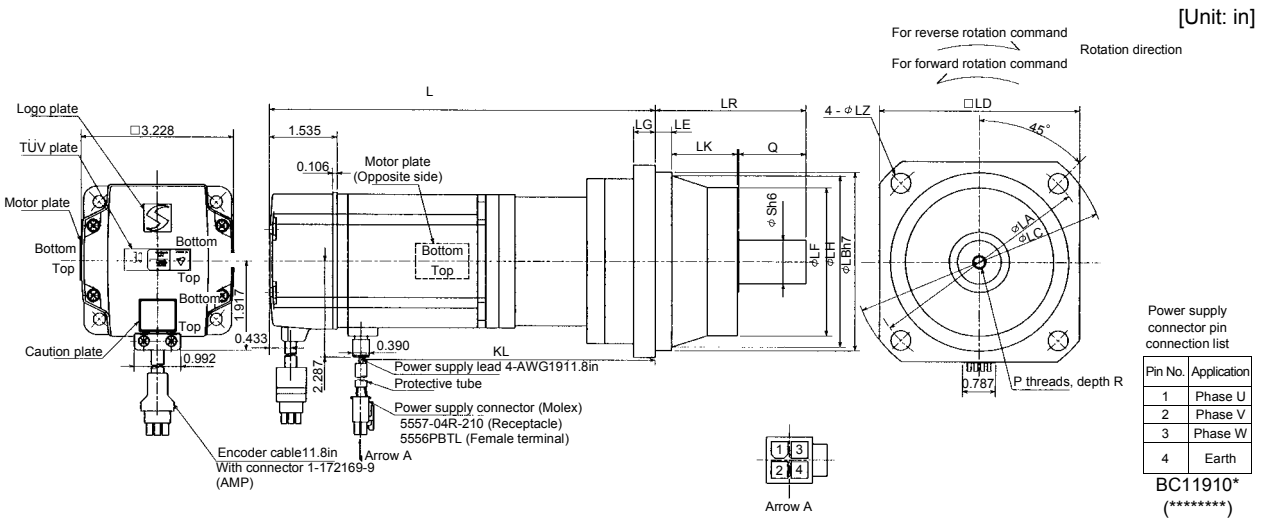

7. OUTLINE DIMENSION DRAWINGS

(b) With electromagnetic brake

Model	Output [W]	Variable Dimensions [in]		Brake static friction torque [oz · in]	Reduction Gear Model	Reduction Ratio	Inertia Moment WK ² [oz · in ²]	Backlash	Mass [lb]
		L	KL						
HC-MFS053BG2	50	6.22	3.07	45	BK1-05B-A5MEKA	1/5	0.38	3 min. max.	4.0
HC-MFS053BG2	50	6.85	3.70	45	BK1-09B-A5MEKA	1/9	0.34	3 min. max.	4.6
HC-MFS053BG2	50	6.85	3.70	45	BK1-20B-A5MEKA	1/20	0.39	3 min. max.	4.9
HC-MFS053BG2	50	6.85	3.70	45	BK1-29B-A5MEKA	1/29	0.33	3 min. max.	4.9
HC-KFS053BG2	50	6.22	3.07	45	BK1-05B-A5MEKA	1/5	0.57	3 min. max.	4.0
HC-KFS053BG2	50	6.85	3.70	45	BK1-09B-A5MEKA	1/9	0.54	3 min. max.	4.6
HC-KFS053BG2	50	6.85	3.70	45	BK1-20B-A5MEKA	1/20	0.59	3 min. max.	4.9
HC-KFS053BG2	50	6.85	3.70	45	BK1-29B-A5MEKA	1/29	0.52	3 min. max.	4.9

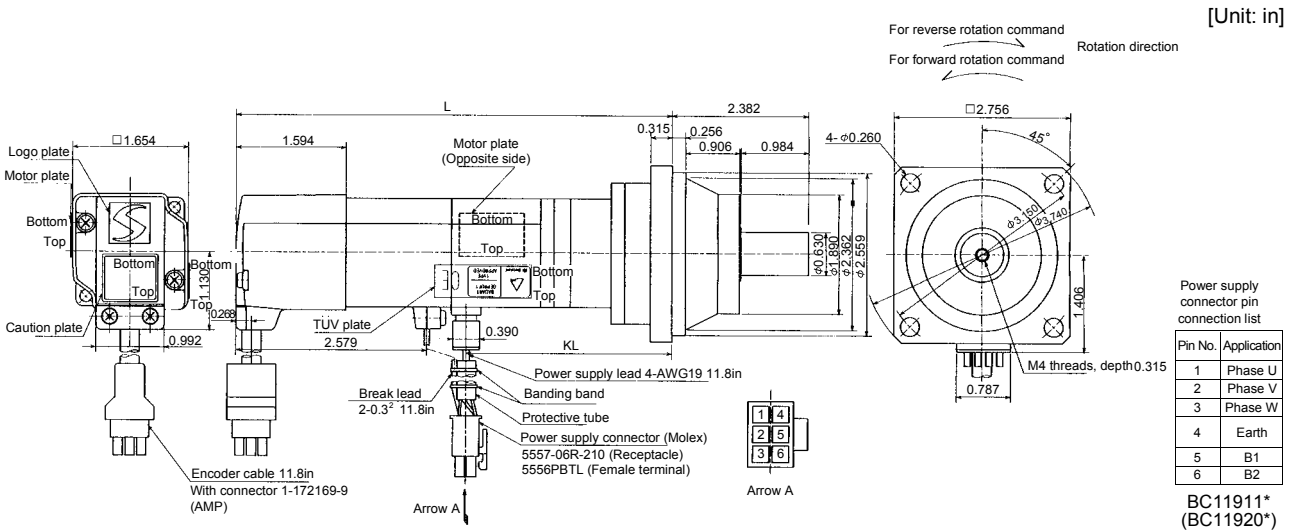

7. OUTLINE DIMENSION DRAWINGS

Model	Output [W]	Brake static friction torque [oz · in]	Reduction Gear Model	Reduction Ratio	Inertia Moment WK^2 [oz · in ²]	Backlash	Mass [lb]
HC-MFS13BG2	100	45	BK1-05B-01MEKA	1/5	0.44	3 min. max.	4.2
HC-MFS13BG2	100	45	BK1-09B-01MEKA	1/9	0.40	3 min. max.	4.9
HC-MFS13BG2	100	45	BK2-20B-01MEKA	1/20	0.68	3 min. max.	7.5
HC-MFS13BG2	100	45	BK2-29B-01MEKA	1/29	0.53	3 min. max.	7.5

Model	Output [W]	Variable Dimensions [in]																
		LA	LB	LC	LD	LE	LF	LG	LH	LK	L	LR	KL	LZ	Q	S	P	R
HC-MFS13BG2	100	3.15	2.56	3.74	2.76	0.24	1.89	0.31	2.362	0.906	6.81	2.17	3.66	0.26	0.98	0.63	M4	0.31
HC-MFS13BG2	100	3.15	2.56	3.74	2.76	0.24	1.89	0.31	2.362	0.906	7.44	2.17	4.29	0.26	0.98	0.63	M4	0.31
HC-MFS13BG2	100	3.94	3.15	4.53	3.35	0.24	2.559	0.39	2.913	1.299	7.68	2.95	4.53	0.26	1.38	0.79	M5	0.39
HC-MFS13BG2	100	3.94	3.15	4.53	3.35	0.24	2.559	0.39	2.913	1.299	7.68	2.95	4.53	0.26	1.38	0.79	M5	0.39

Model	Output [W]	Brake static friction torque [oz · in]	Reduction Gear Model	Reduction Ratio	Inertia Moment WK^2 [oz · in ²]	Backlash	Mass [lb]
HC-KFS13BG2	100	45	BK1-05B-01MEKA	1/5	0.74	3 min. max.	4.2
HC-KFS13BG2	100	45	BK1-09B-01MEKA	1/9	0.71	3 min. max.	4.9
HC-KFS13BG2	100	45	BK2-20B-01MEKA	1/20	0.98	3 min. max.	7.5
HC-KFS13BG2	100	45	BK2-29B-01MEKA	1/29	0.84	3 min. max.	7.5

Model	Output [W]	Variable Dimensions [in]																
		LA	LB	LC	LD	LE	LF	LG	LH	LK	L	LR	KL	LZ	Q	S	P	R
HC-KFS13BG2	100	3.15	2.56	3.74	2.76	0.24	1.89	0.31	2.362	0.906	6.81	2.17	3.66	0.26	0.98	0.63	M4	0.31
HC-KFS13BG2	100	3.15	2.56	3.74	2.76	0.24	1.89	0.31	2.362	0.906	7.44	2.17	4.29	0.26	0.98	0.63	M4	0.31
HC-KFS13BG2	100	3.94	3.15	4.53	3.35	0.24	2.559	0.39	2.913	1.299	7.68	2.95	4.53	0.26	1.38	0.79	M5	0.39
HC-KFS13BG2	100	3.94	3.15	4.53	3.35	0.24	2.559	0.39	2.913	1.299	7.68	2.95	4.53	0.26	1.38	0.79	M5	0.39

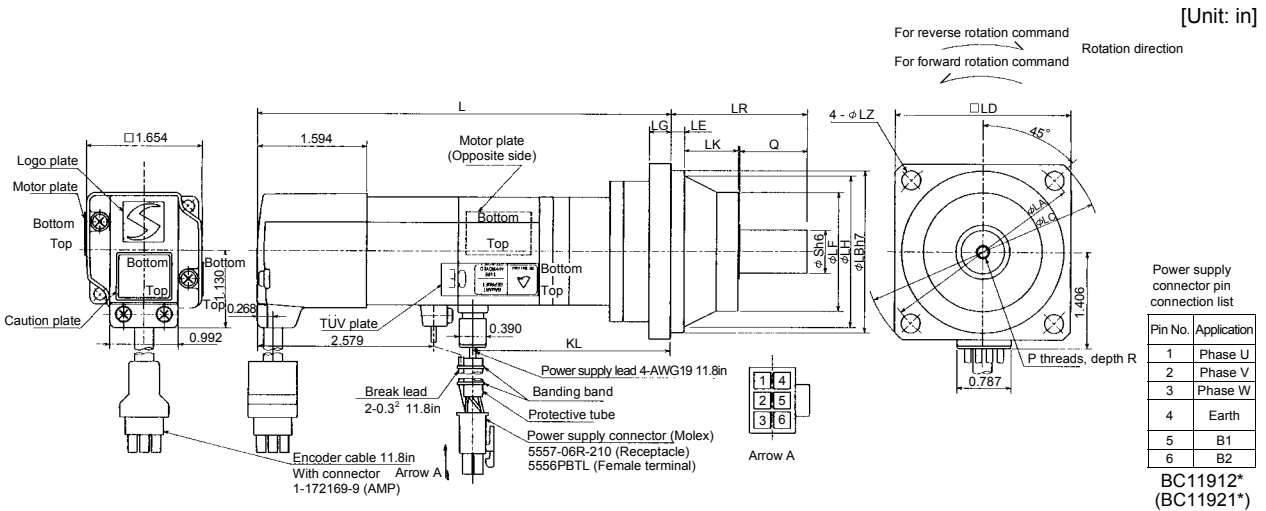

7. OUTLINE DIMENSION DRAWINGS

Model	Output [W]	Brake static friction torque [oz · in]	Reduction Gear Model	Reduction Ratio	Inertia Moment WK ² [oz · in ²]	Mass [lb]
HC-MFS23BG2	200	184	BK1-05B-02MEKA	1/5	1.31	6.0
HC-MFS23BG2	200	184	BK2-09B-02MEKA	1/9	1.40	9.0
HC-MFS23BG2	200	184	BK3-20B-02MEKA	1/20	2.21	12.3
HC-MFS23BG2	200	184	BK3-29B-02MEKA	1/29	1.77	12.3

Model	Output [W]	Variable Dimensions [in]																
		LA	LB	LC	LD	LE	LF	LG	LH	LK	L	LR	KL	LZ	Q	S	P	R
HC-MFS23BG2	200	3.15	2.56	3.74	2.76	0.24	1.89	0.31	2.362	0.906	7.44	2.17	4.20	0.26	0.98	0.63	M4	0.31
HC-MFS23BG2	200	3.94	3.15	4.53	3.35	0.24	2.559	0.39	2.913	1.299	8.15	2.95	4.91	0.26	1.38	0.79	M5	0.39
HC-MFS23BG2	200	4.53	3.74	5.31	3.94	0.31	2.953	0.39	3.346	1.378	8.35	3.35	5.10	0.35	1.57	0.98	M6	0.47
HC-MFS23BG2	200	4.53	3.74	5.31	3.94	0.31	2.953	0.39	3.346	1.378	8.35	3.35	5.10	0.35	1.57	0.98	M6	0.47

Model	Output [W]	Brake static friction torque [oz · in]	Reduction Gear Model	Reduction Ratio	Inertia Moment WK ² [oz · in ²]	Mass [lb]
HC-KFS23BG2	200	184	BK1-05B-02MEKA	1/5	2.242	6.0
HC-KFS23BG2	200	184	BK2-09B-02MEKA	1/9	2.351	9.0
HC-KFS23BG2	200	184	BK3-20B-02MEKA	1/20	3.171	12.3
HC-KFS23BG2	200	184	BK3-29B-02MEKA	1/29	2.734	12.3

Model	Output [W]	Variable Dimensions [in]																
		LA	LB	LC	LD	LE	LF	LG	LH	LK	L	LR	KL	LZ	Q	S	P	R
HC-KFS23BG2	200	3.15	2.56	3.74	2.76	0.24	1.89	0.31	2.362	0.906	7.44	2.17	4.20	0.26	0.98	0.63	M4	0.31
HC-KFS23BG2	200	3.94	3.15	4.53	3.35	0.24	2.559	0.39	2.913	1.299	8.15	2.95	4.91	0.26	1.38	0.79	M5	0.39
HC-KFS23BG2	200	4.53	3.74	5.31	3.94	0.31	2.953	0.39	3.346	1.378	8.35	3.35	5.10	0.35	1.57	0.98	M6	0.47
HC-KFS23BG2	200	4.53	3.74	5.31	3.94	0.31	2.953	0.39	3.346	1.378	8.35	3.35	5.10	0.35	1.57	0.98	M6	0.47

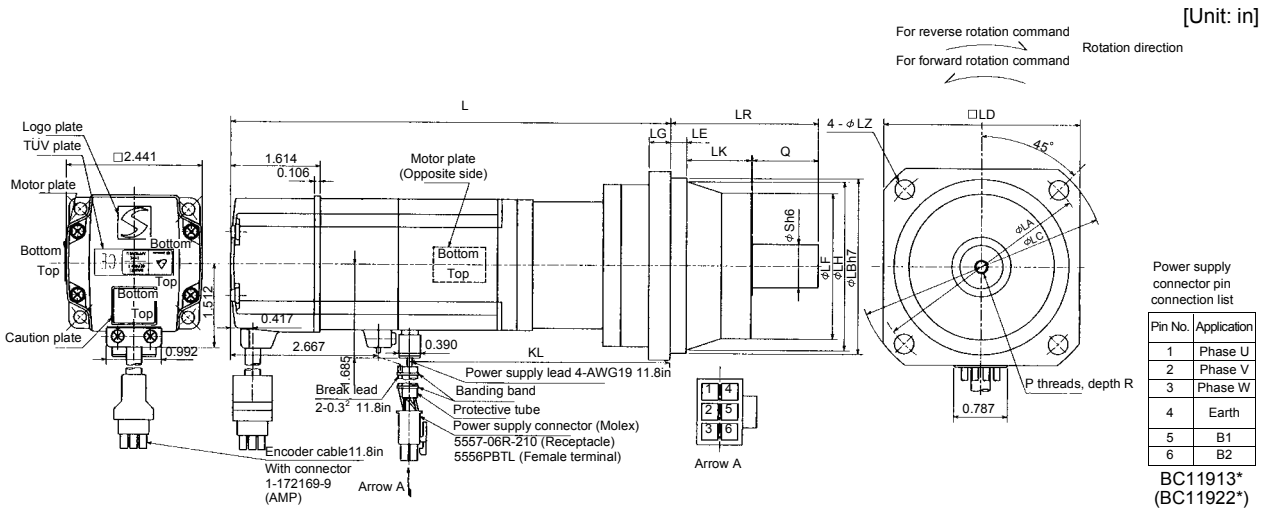

7. OUTLINE DIMENSION DRAWINGS

Model	Output [W]	Brake static friction torque [oz · in]	Reduction Gear Model	Reduction Ratio	Inertia Moment WK ² [oz · in ²]	Mass [lb]
HC-MFS43BG2	400	184	BK2-05B-04MEKA	1/5	1.88	9.5
HC-MFS43BG2	400	184	BK3-09B-04MEKA	1/9	2.03	13.0
HC-MFS43BG2	400	184	BK4-20B-04MEKA	1/20	2.59	17.9
HC-MFS43BG2	400	184	BK4-29B-04MEKA	1/29	2.11	17.9

Model	Output [W]	Variable Dimensions [in]																
		LA	LB	LC	LD	LE	LF	LG	LH	LK	L	LR	KL	LZ	Q	S	P	R
HC-MFS43BG2	400	3.94	3.15	4.53	3.35	0.24	2.559	0.39	2.913	1.299	8.50	2.95	5.18	0.26	1.38	0.79	M5	0.39
HC-MFS43BG2	400	4.53	3.74	5.31	3.94	0.31	2.953	0.39	3.346	1.378	9.33	3.35	6.01	0.35	1.57	0.98	M6	0.47
HC-MFS43BG2	400	5.31	4.33	6.10	4.53	0.31	3.543	0.47	3.937	1.575	9.57	3.94	6.24	0.43	1.97	1.26	M8	0.63
HC-MFS43BG2	400	5.31	4.33	6.10	4.53	0.31	3.543	0.47	3.937	1.575	9.57	3.94	6.24	0.43	1.97	1.26	M8	0.63

Model	Output [W]	Brake static friction torque [oz · in]	Reduction Gear Model	Reduction Ratio	Inertia Moment WK ² [oz · in ²]	Mass [lb]
HC-KFS43BG2	400	184	BK2-05B-04MEKA	1/5	3.609	9.5
HC-KFS43BG2	400	184	BK3-09B-04MEKA	1/9	3.773	13.0
HC-KFS43BG2	400	184	BK4-20B-04MEKA	1/20	4.319	17.9
HC-KFS43BG2	400	184	BK4-29B-04MEKA	1/29	3.882	17.9

Model	Output [W]	Variable Dimensions [in]																
		LA	LB	LC	LD	LE	LF	LG	LH	LK	L	LR	KL	LZ	Q	S	P	R
HC-KFS43BG2	400	3.94	3.15	4.53	3.35	0.24	2.559	0.39	2.913	1.299	8.50	2.95	5.18	0.26	1.38	0.79	M5	0.39
HC-KFS43BG2	400	4.53	3.74	5.31	3.94	0.31	2.953	0.39	3.346	1.378	9.33	3.35	6.01	0.35	1.57	0.98	M6	0.47
HC-KFS43BG2	400	5.31	4.33	6.10	4.53	0.31	3.543	0.47	3.937	1.575	9.57	3.94	6.24	0.43	1.97	1.26	M8	0.63
HC-KFS43BG2	400	5.31	4.33	6.10	4.53	0.31	3.543	0.47	3.937	1.575	9.57	3.94	6.24	0.43	1.97	1.26	M8	0.63

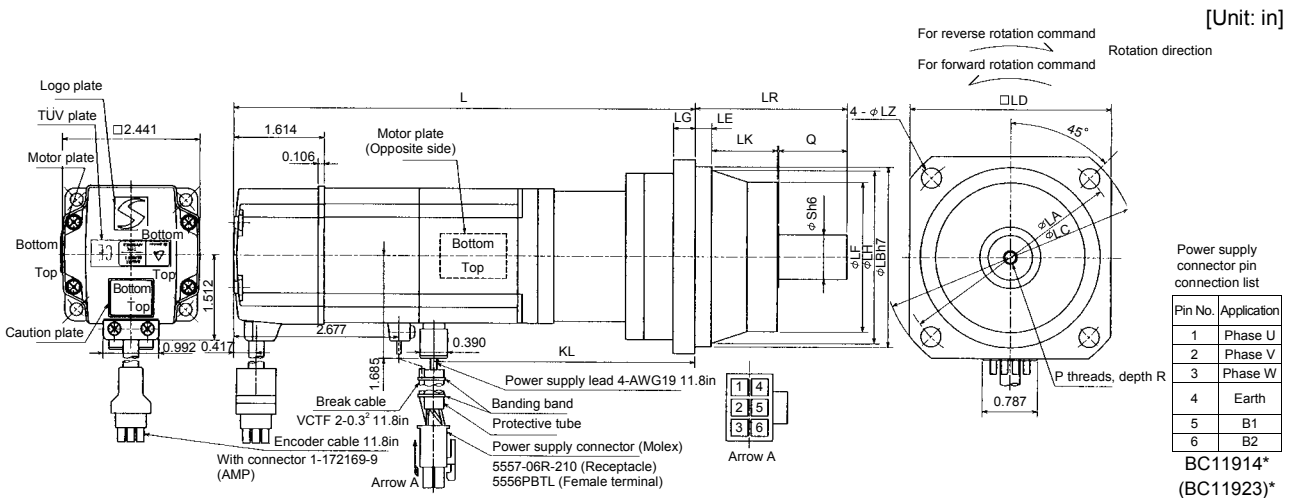

7. OUTLINE DIMENSION DRAWINGS

Model	Output [W]	Brake static friction torque [oz · in]	Reduction Gear Model	Reduction Ratio	Inertia Moment WK ² [oz · in ²]	Mass [lb]
HC-MFS73BG2	750	340	BK3-05B-08MEKA	1/5	6.00	16.1
HC-MFS73BG2	750	340	BK4-09B-08MEKA	1/9	6.04	21.2
HC-MFS73BG2	750	340	BK5-20B-08MEKA	1/20	6.24	28.7
HC-MFS73BG2	750	340	BK5-29B-08MEKA	1/29	5.66	28.7

Model	Output [W]	Variable Dimensions [in]																
		LA	LB	LC	LD	LE	LF	LG	LH	LK	L	LR	KL	LZ	Q	S	P	R
HC-MFS73BG2	750	4.53	3.74	5.31	3.94	0.31	2.953	0.39	3.346	1.378	9.74	3.35	6.17	0.35	1.57	0.98	M6	0.47
HC-MFS73BG2	750	5.31	4.33	6.10	4.53	0.31	3.543	0.47	3.937	1.575	11.16	3.94	7.59	0.43	1.97	1.26	M8	0.63
HC-MFS73BG2	750	5.91	4.92	6.89	5.12	0.39	4.134	0.59	4.528	1.693	11.16	4.53	7.59	0.55	2.36	1.57	M10	0.79
HC-MFS73BG2	750	5.91	4.92	6.89	5.12	0.39	4.134	0.59	4.528	1.693	11.16	4.53	7.59	0.55	2.36	1.57	M10	0.79

Model	Output [W]	Brake static friction torque [oz · in]	Reduction Gear Model	Reduction Ratio	Inertia Moment WK ² [oz · in ²]	Mass [lb]
HC-KFS73BG2	750	340	BK3-05B-08MEKA	1/5	10.98	16.1
HC-KFS73BG2	750	340	BK4-09B-08MEKA	1/9	11.02	21.2
HC-KFS73BG2	750	340	BK5-20B-08MEKA	1/20	11.21	28.7
HC-KFS73BG2	750	340	BK5-29B-08MEKA	1/29	10.63	28.7

Model	Output [W]	Variable Dimensions [in]																
		LA	LB	LC	LD	LE	LF	LG	LH	LK	L	LR	KL	LZ	Q	S	P	R
HC-KFS73BG2	750	4.53	3.74	5.31	3.94	0.31	2.953	0.39	3.346	1.378	9.74	3.35	6.17	0.35	1.57	0.98	M6	0.47
HC-KFS73BG2	750	5.31	4.33	6.10	4.53	0.31	3.543	0.47	3.937	1.575	10.85	3.94	7.27	0.43	1.97	1.26	M8	0.63
HC-KFS73BG2	750	5.91	4.92	6.89	5.12	0.39	4.134	0.59	4.528	1.693	11.16	4.53	7.59	0.55	2.36	1.57	M10	0.79
HC-KFS73BG2	750	5.91	4.92	6.89	5.12	0.39	4.134	0.59	4.528	1.693	11.16	4.53	7.59	0.55	2.36	1.57	M10	0.79

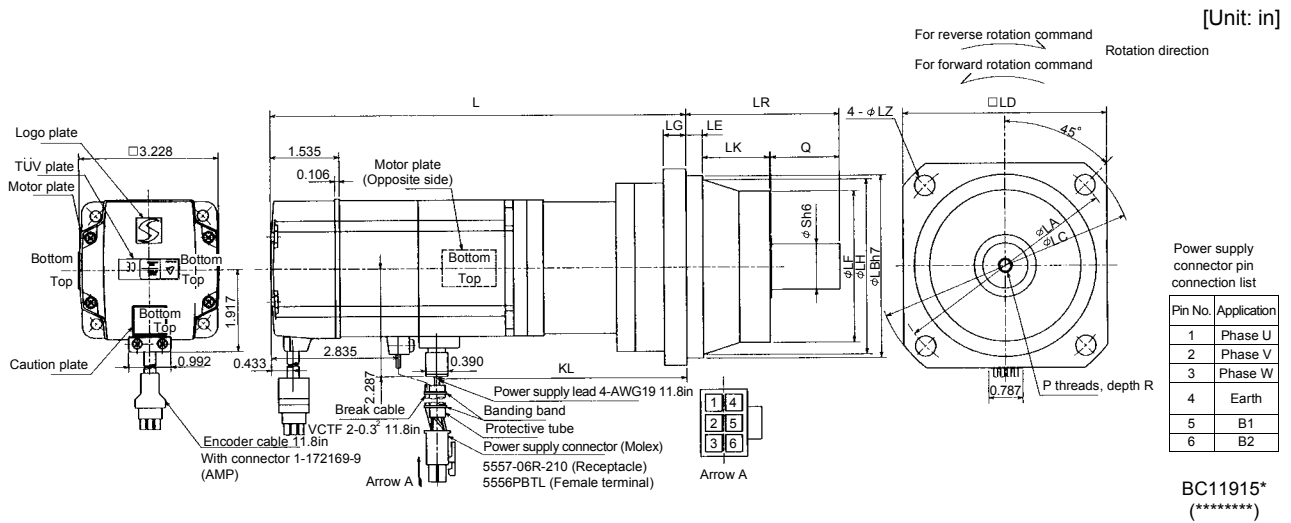

7. OUTLINE DIMENSION DRAWINGS

7.2.12 HC-UFS 3000r/min series

(1) Standard (without electromagnetic brake)

Model	Output [W]	Inertia Moment WK ² [oz · in ²]	Mass [lb]
HC-UFS13	100	0.36	1.76

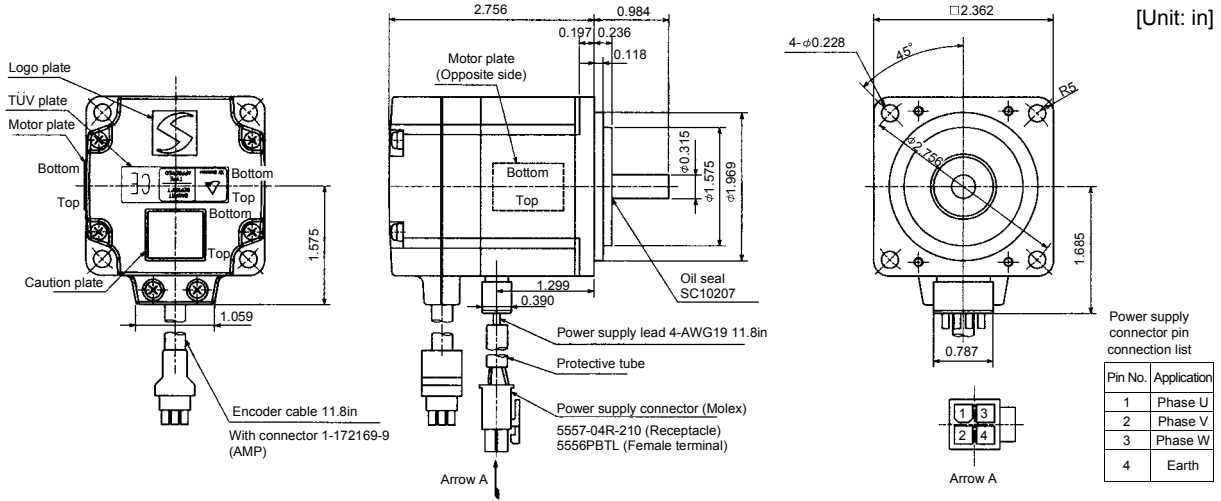

BC11876*

Model	Output [W]	Variable Dimensions [in]		Inertia Moment WK ² [oz · in ²]	Mass [lb]
		L	KL		
HC-UFS23	200	3.03	1.72	1.32	3.31
HC-UFS43	400	3.62	2.31	2.00	3.75

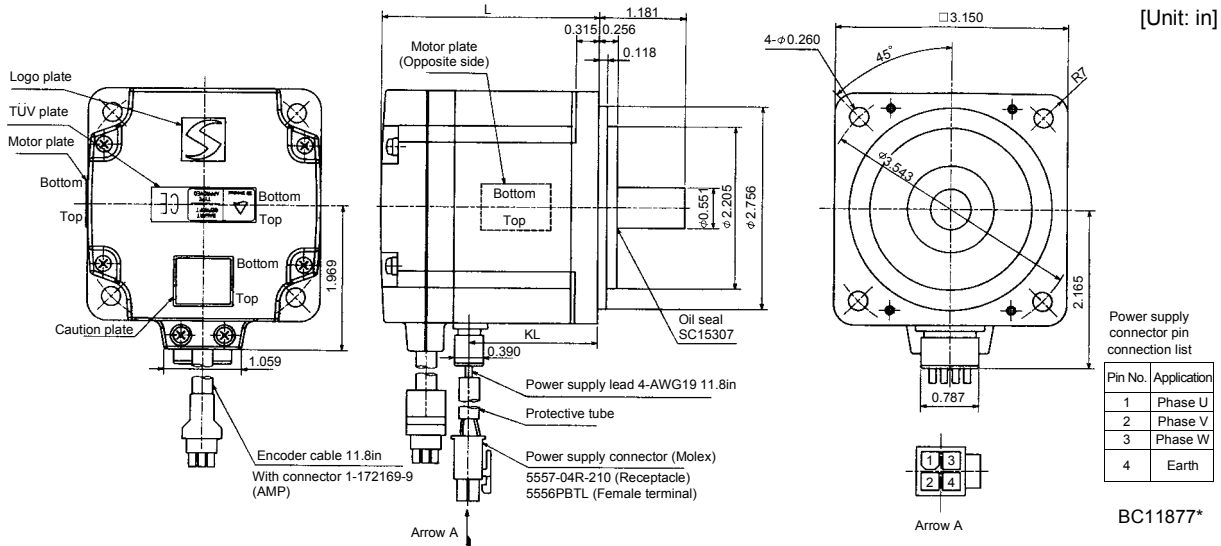

BC11877*

7. OUTLINE DIMENSION DRAWINGS

Model	Output [W]	Inertia Moment WK^2 [oz · in ²]	Mass [lb]
HC-UFS73	750	32.26	11.02

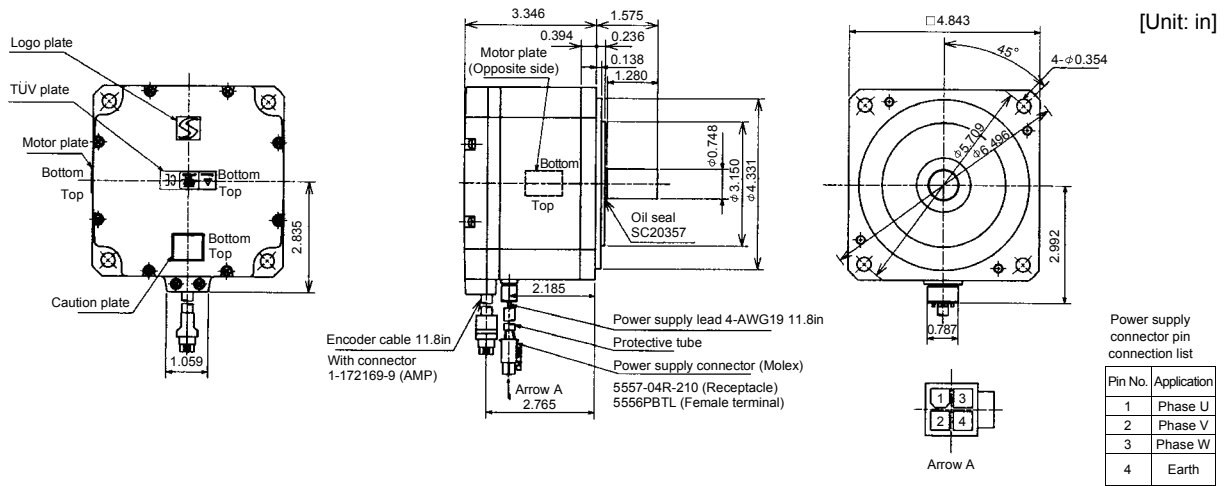

BC11878*

(2) With electromagnetic brake

Model	Output [W]	Brake static friction torque [oz · in]	Inertia Moment WK^2 [oz · in ²]	Mass [lb]
HC-UFS13B	100	45.32	0.41	2.65

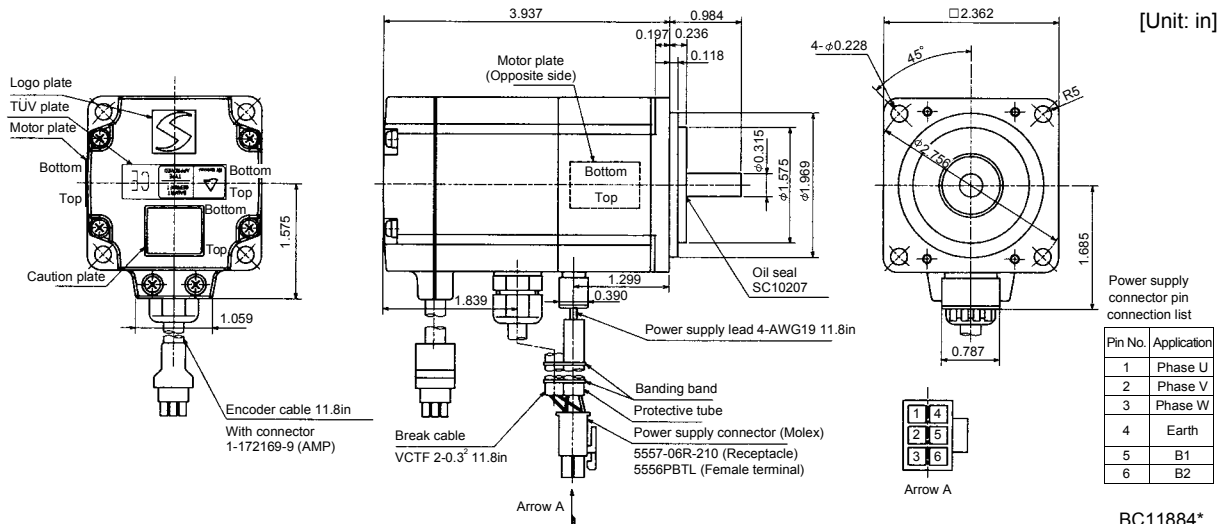

BC11884*

7. OUTLINE DIMENSION DRAWINGS

Model	Output [W]	Variable Dimensions [in]		Brake static friction torque [oz · in]	Inertia Moment WK^2 [oz · in ²]	Mass [lb]
		L	KL			
HC-UFS23B	200	4.37	1.72	184.1	1.77	4.85
HC-UFS43B	400	4.96	2.31	184.1	2.44	5.29

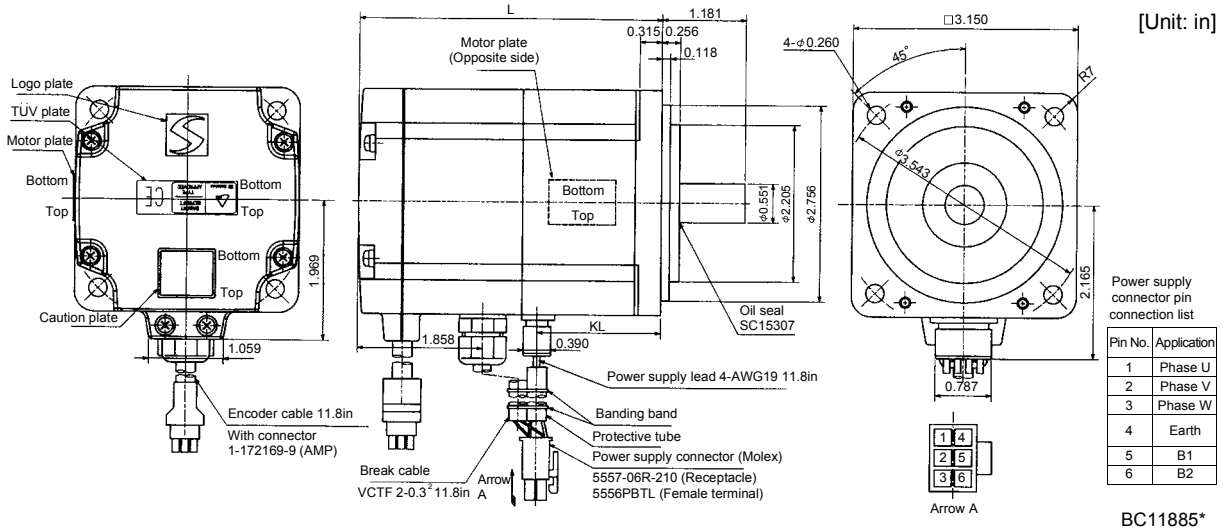

Model	Output [W]	Brake static friction torque [oz · in]	Inertia Moment WK^2 [oz · in ²]	Mass [lb]
HC-UFS73B	750	339.87	33.35	13.67

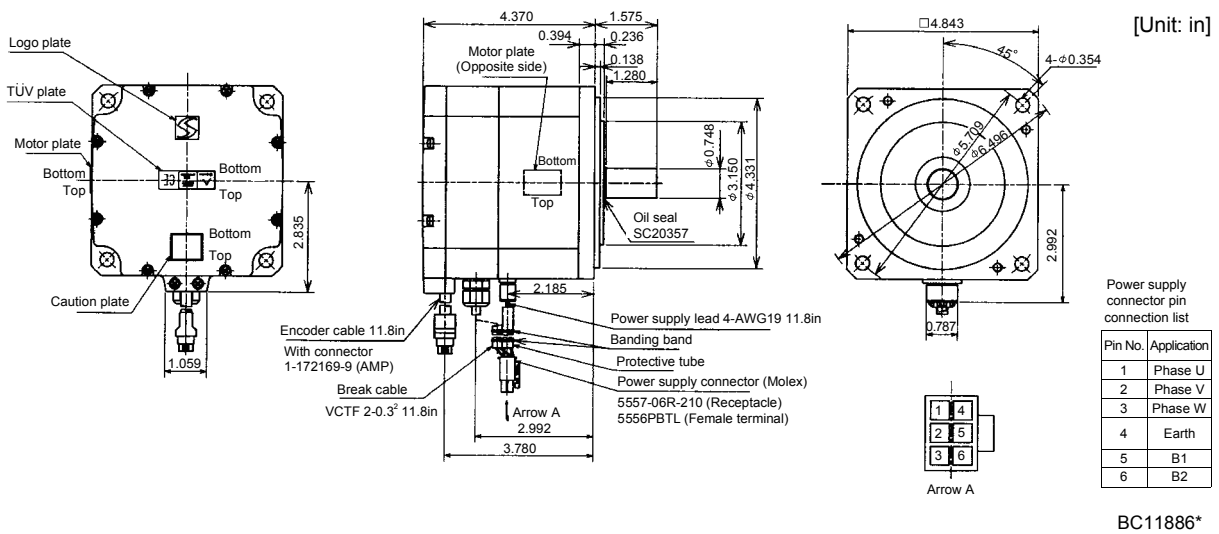

7. OUTLINE DIMENSION DRAWINGS

7.2.13 HA-LFS series

Terminal box detail diagram

Motor Model	HA-LFS15K1	HA-LFS25K1 to 37K1 HA-LFS30K1M • 37K1M HA-LFS30K2 • 37K2 HA-LFS25K14 to 37K14 HA-LFS37K1M4 to 50K1M4 HA-LFS45K24 • 55K24	
	HA-LFS20K1		
	HA-LFS22K1M		
	HA-LFS15K14		
	HA-LFS20K14		
	HA-LFS22K1M4		
	HA-LFS30K1M4		
	HA-LFS30K24		
HA-LFS37K24			
Motor power supply lead size	0.0124in ² (AWG8) × 2 parallel	0.0341in ² (AWG4) × 2 parallel	
Motor power supply terminal block screw size	M8	M10	
Terminal box dimensions (in)	LA	8.661	10.472
	LB	8.268	9.055

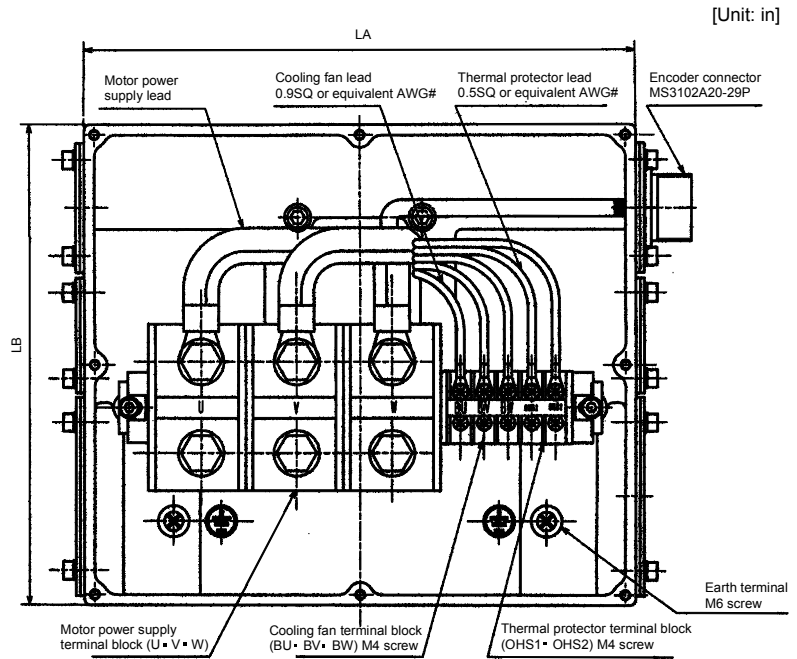

HA-LFS 601 • 701M • 6014 • 701M4 • 11K2 • 11K24 terminal box detail diagram

(Note)[Unit: in]

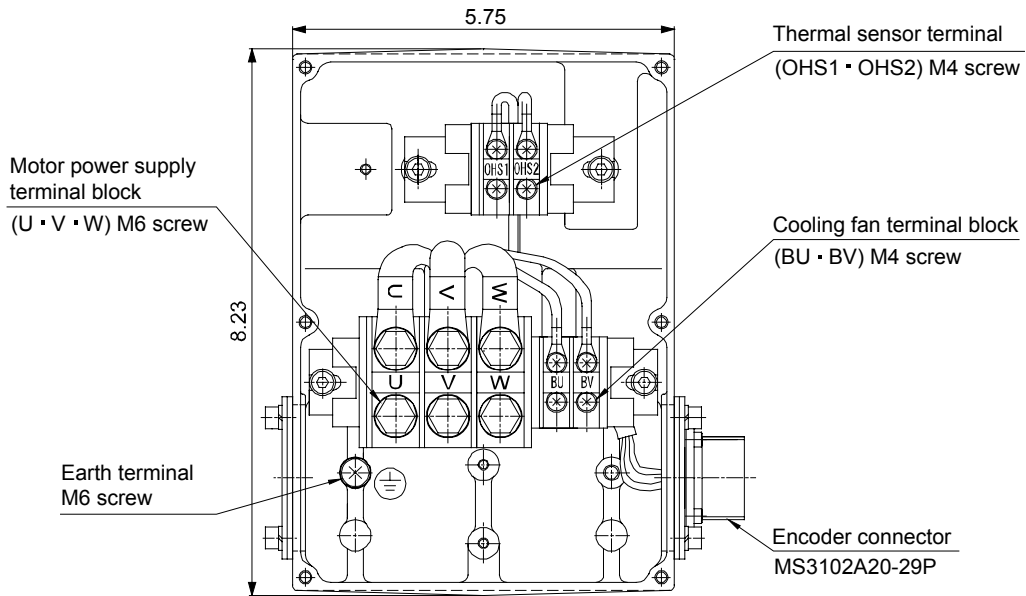

BG72707C

Note. The dimensions without tolerances are reference dimensions.

7. OUTLINE DIMENSION DRAWINGS

HA-LFS 801 · 12K1 · 11K1M · 15K1M · 15K2 · 22K2 · 8014 · 12K14 · 11K1M4 · 15K1M4 · 15K24 · 22K24
terminal box detail diagram

(Note)[Unit: in]

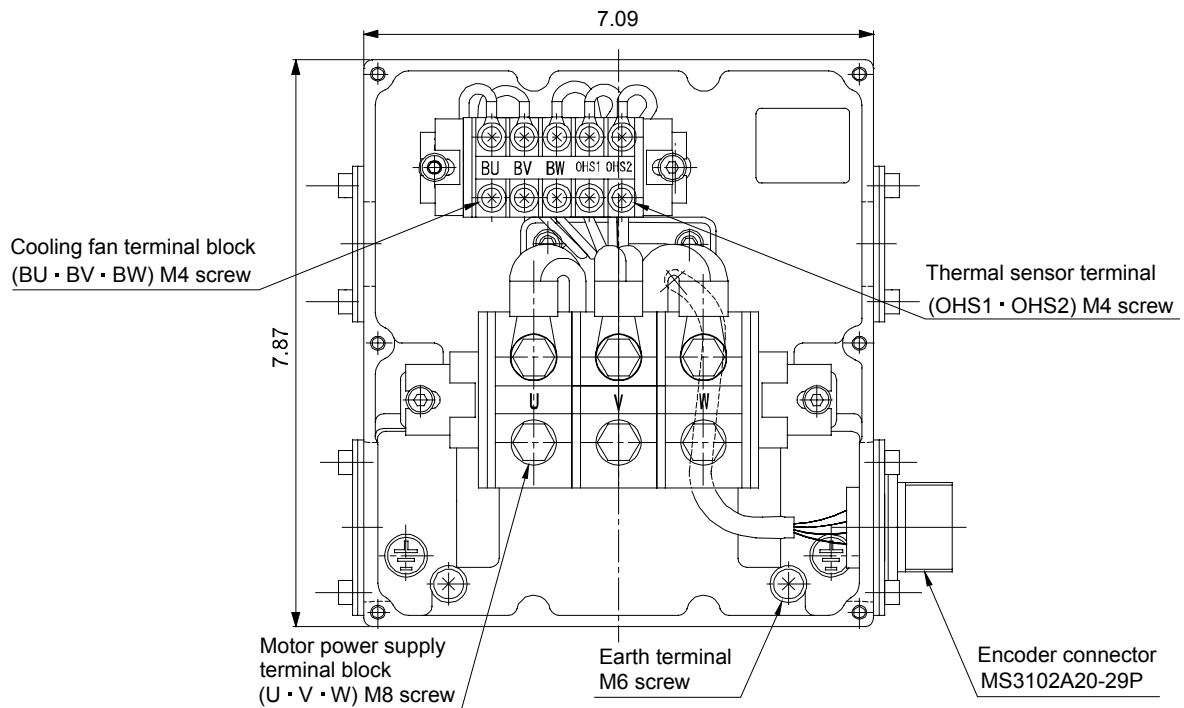

BG72706

Note. The dimensions without tolerances are reference dimensions.

7. OUTLINE DIMENSION DRAWINGS

(1) Standard (without electromagnetic brake, without reduction gear)

Model	Output [kW]	Inertia Moment WK ² [oz · in ²]	Mass [lb]
HA-LFS502	5	404.59	61.73

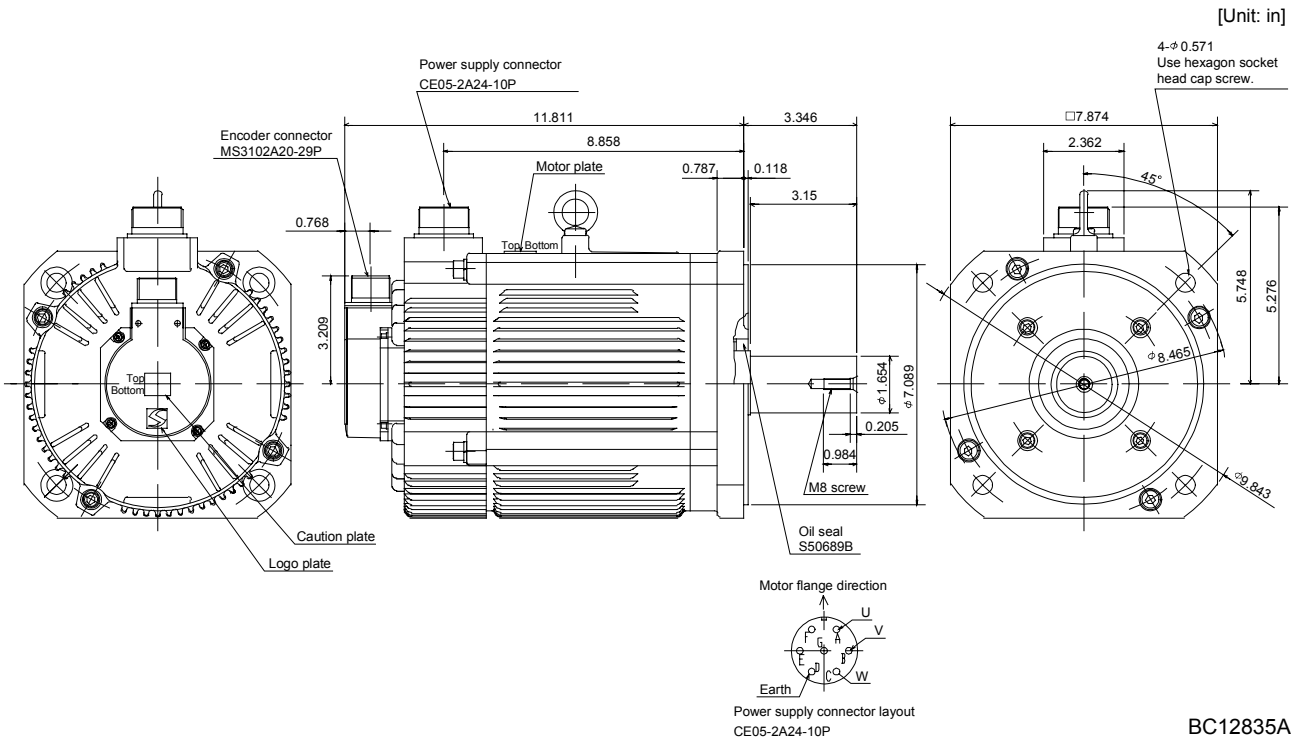

Model	Output [kW]	Inertia Moment WK ² [oz · in ²]	Mass [lb]
HA-LFS702	7	515.03	77.16

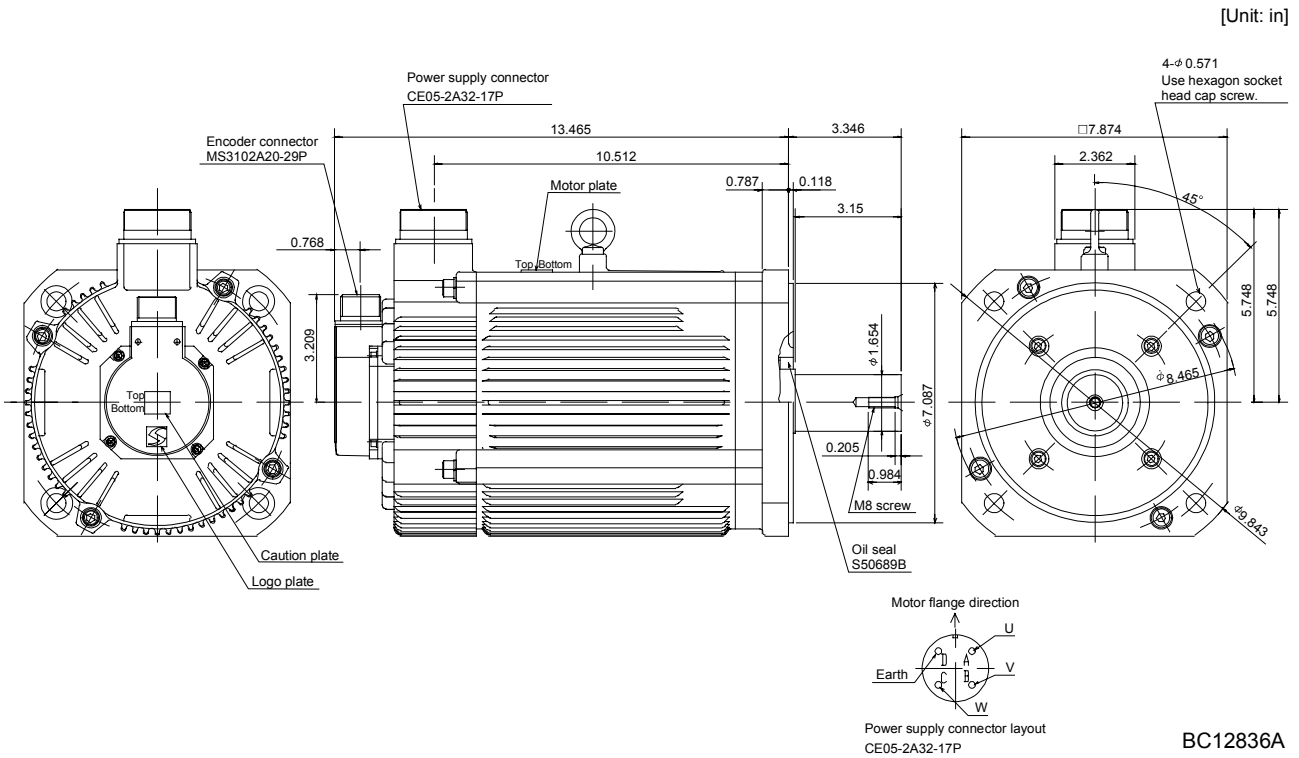

7. OUTLINE DIMENSION DRAWINGS

Model	Output [kW]	Inertia Moment WK ² [oz · in ²]	Mass [lb]
HA-LFS601 HA-LFS6014	6	574.08	121.25
HA-LFS701M HA-LFS701M4	7		
HA-LFS11K2 HA-LFS11K24	11		

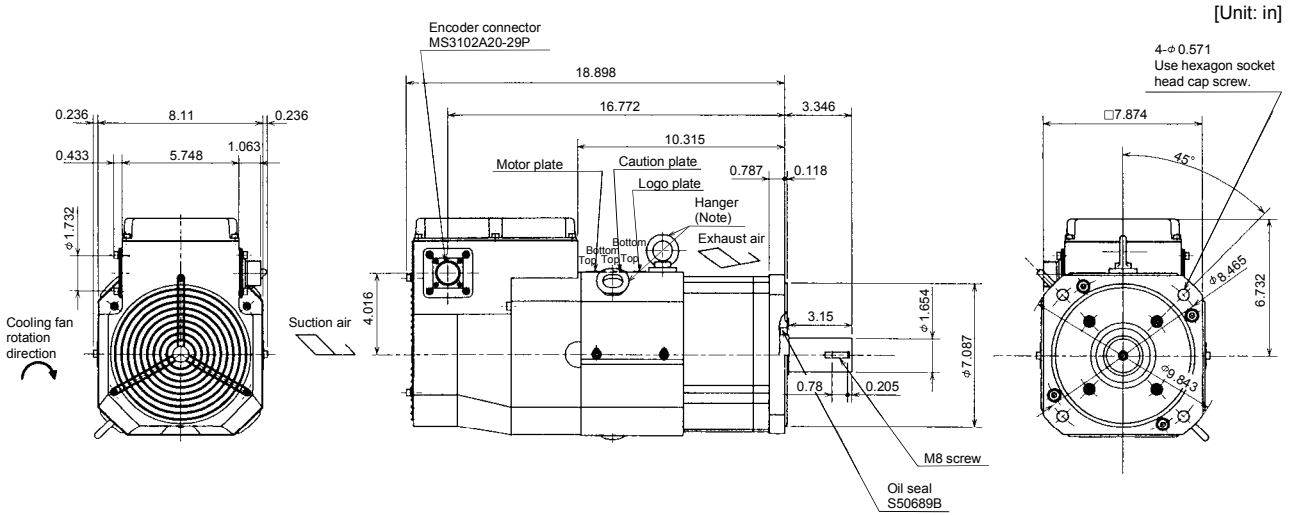

BC12837A, BC12582*, BC12967A

Note. When the motor is used without the hanger, plug the threaded hole with a bolt of M10 X 20 mm or less.

Model	Output [kW]	Inertia Moment WK ² [oz · in ²]	Mass [lb]
HA-LFS801 HA-LFS8014	8	1202.84	209.44
HA-LFS11K1M HA-LFS11K1M4	11		
HA-LFS15K2 HA-LFS15K24	15		

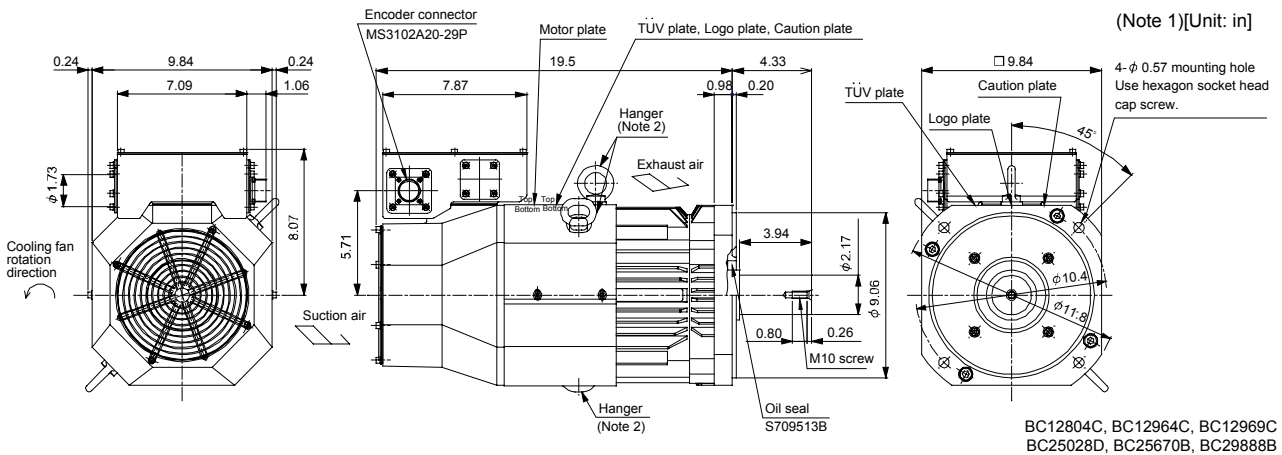

BC12804C, BC12964C, BC12969C
BC25028D, BC25670B, BC29888B

Note 1. The dimensions without tolerances are reference dimensions.
2. When the motor is used without the hanger, plug the threaded hole with a bolt of M12 X 20 mm or less.

7. OUTLINE DIMENSION DRAWINGS

Model	Output [kW]	Inertia Moment WK ² [oz · in ²]	Mass [lb]
HA-LFS12K1 HA-LFS12K14	12	1612.9	253.53
HA-LFS15K1M HA-LFS15K1M4	15		
HA-LFS22K2 HA-LFS22K24	22		

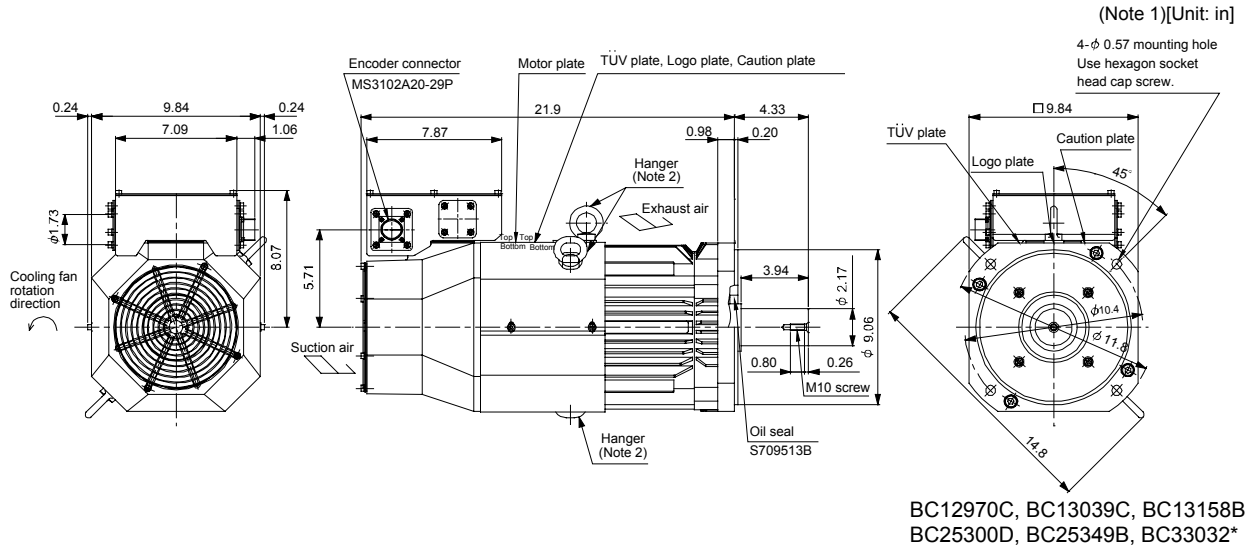

Note 1. The dimensions without tolerances are reference dimensions.
2. When the motor is used without the hanger, plug the threaded hole with a bolt of M12 X 20 mm or less.

Model	Output [kW]	Inertia Moment WK ² [oz · in ²]	Mass [lb]
HA-LFS15K1 HA-LFS15K14	15	3007.1	352.74
HA-LFS22K1M HA-LFS22K1M4	22		
HA-LFS30K24	30		

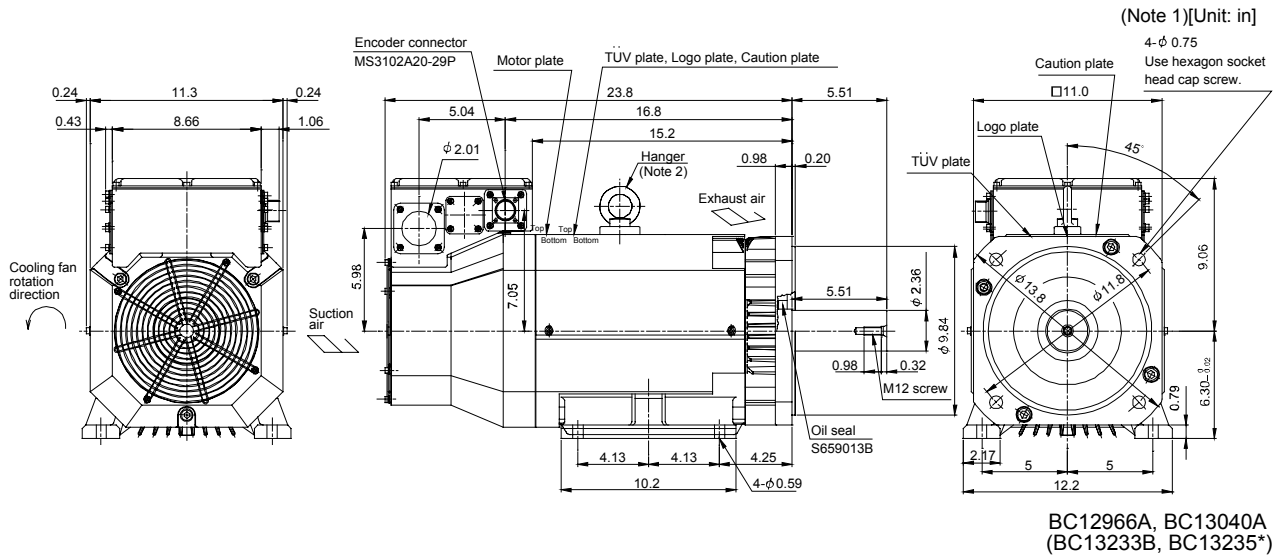

Note 1. The dimensions without tolerances are reference dimensions.
2. When the motor is used without the hanger, plug the threaded hole with a bolt of M12 X 20 mm or less.

7. OUTLINE DIMENSION DRAWINGS

Model	Output [kW]	Inertia Moment WK ² [oz · in ²]	Mass [lb]
HA-LFS20K1 HA-LFS20K14	20	3553.84	396.83
HA-LFS30K1M4	30		
HA-LFS37K24	37		

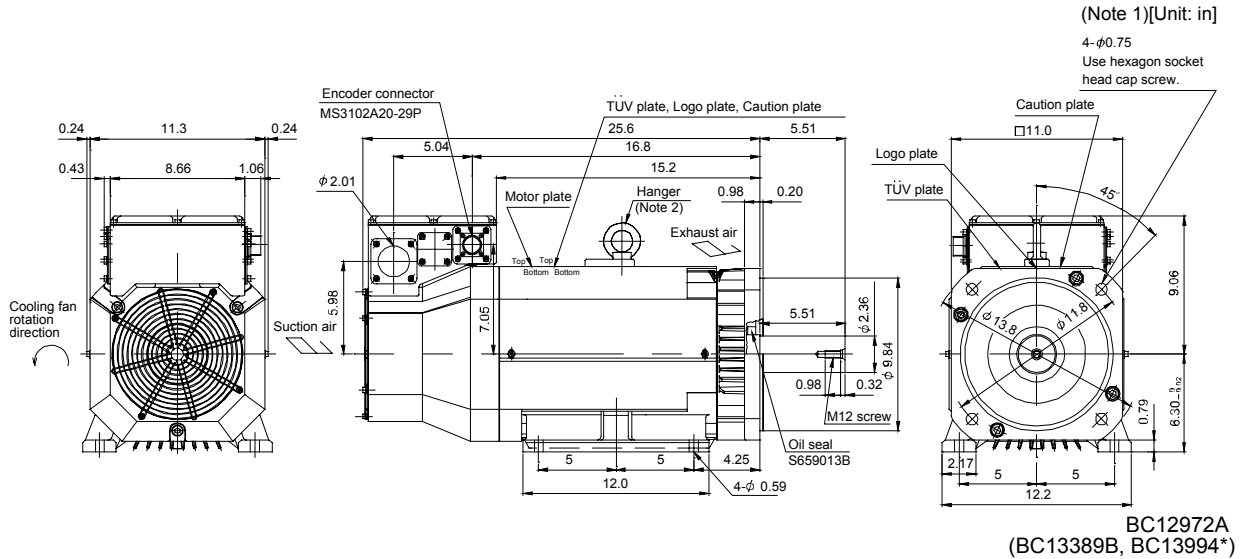

Note 1. The dimensions without tolerances are reference dimensions.
2. When the motor is used without the hanger, plug the threaded hole with a bolt of M16 X 20 mm or less.

Model	Output [kW]	Inertia Moment WK ² [oz · in ²]	Mass [lb]
HA-LFS25K1 HA-LFS25K14	25	5904.84	507.06
HA-LFS37K1M HA-LFS37K1M4	37		
HA-LFS45K24	45		

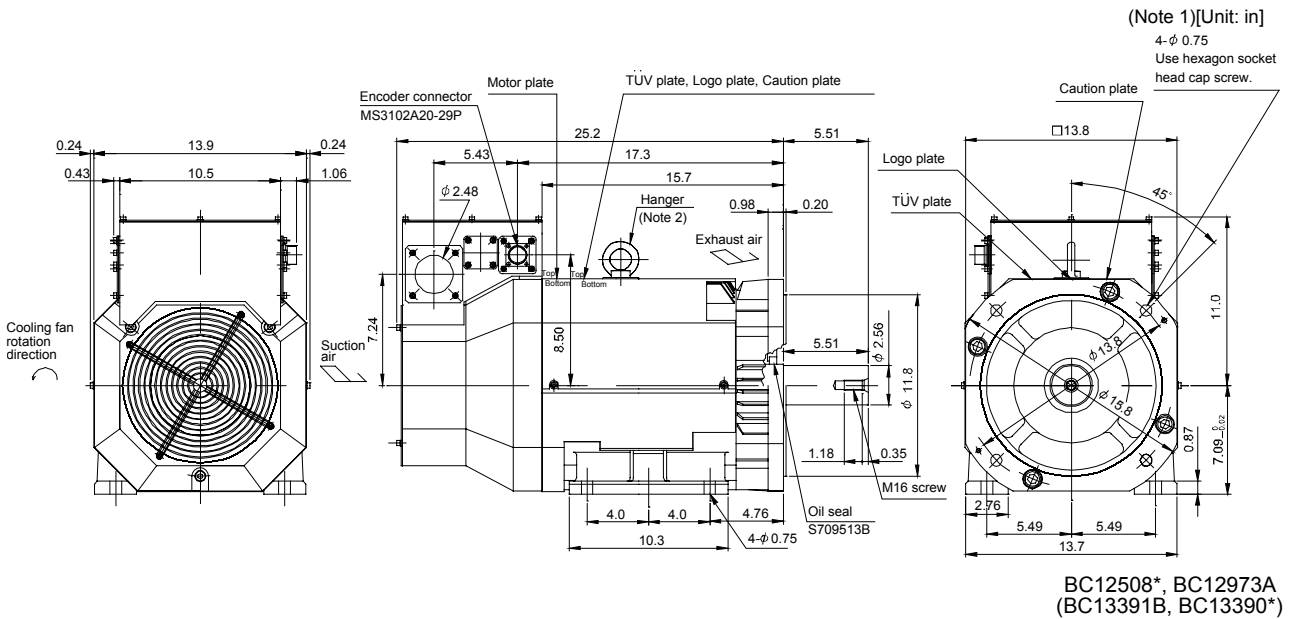

Note 1. The dimensions without tolerances are reference dimensions.
2. When the motor is used without the hanger, plug the threaded hole with a bolt of M16 X 20 mm or less.

7. OUTLINE DIMENSION DRAWINGS

Model	Output [kW]	Inertia Moment WK^2 [oz · in ²]	Mass [lb]
HA-LFS30K1 HA-LFS330K14	30	7162.35	551.16
HA-LFS45K1M4	45		
HA-LFS55K24	55		

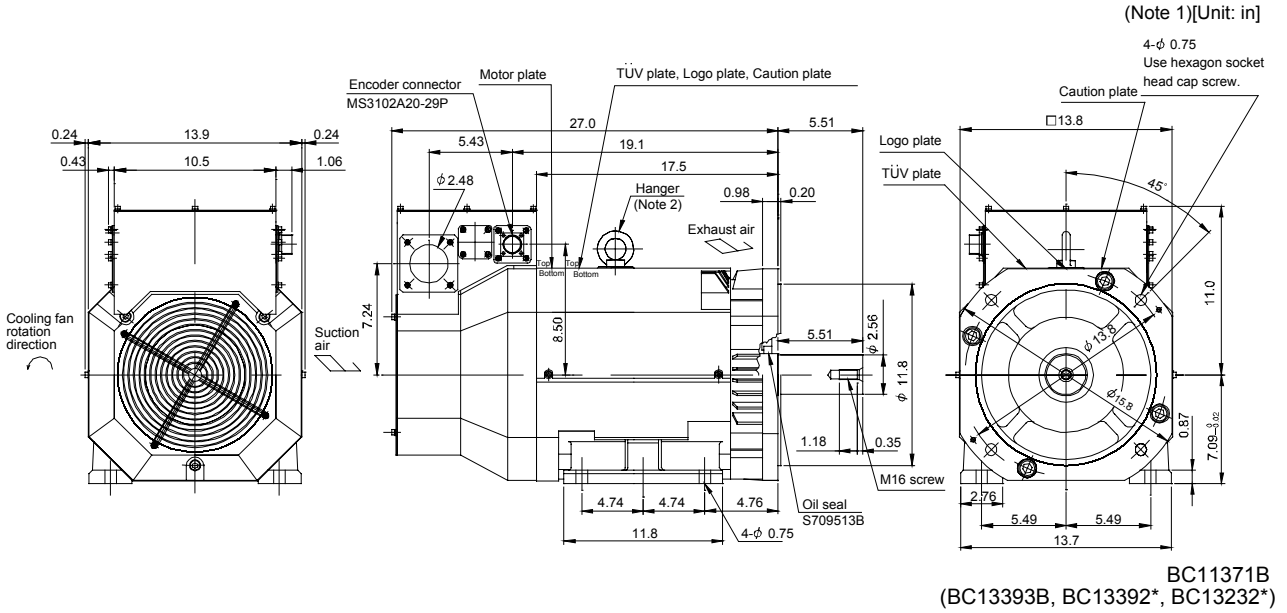

Note 1. The dimensions without tolerances are reference dimensions.

2. When the motor is used without the hanger, plug the threaded hole with a bolt of M16 X 20 mm or less.

Model	Output [kW]	Inertia Moment WK^2 [oz · in ²]	Mass [lb]
HA-LFS37K1 HA-LFS37K14	37	10224.12	738.55
HA-LFS50K1M4	50		

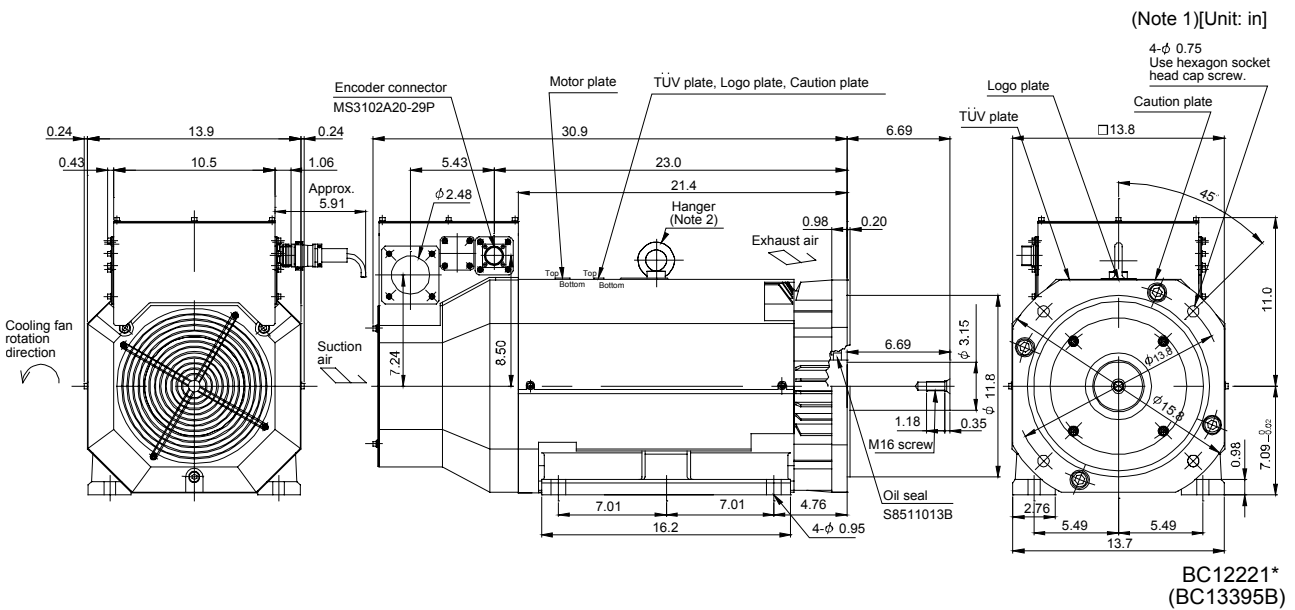

Note 1. The dimensions without tolerances are reference dimensions.

2. When the motor is used without the hanger, plug the threaded hole with a bolt of M16 X 20 mm or less.

7. OUTLINE DIMENSION DRAWINGS

Model	Output [kW]	Inertia Moment WK ² [oz · in ²]	Mass [lb]
HA-LFS30K1M	30	3553.84	396.83
HA-LFS37K2	37		

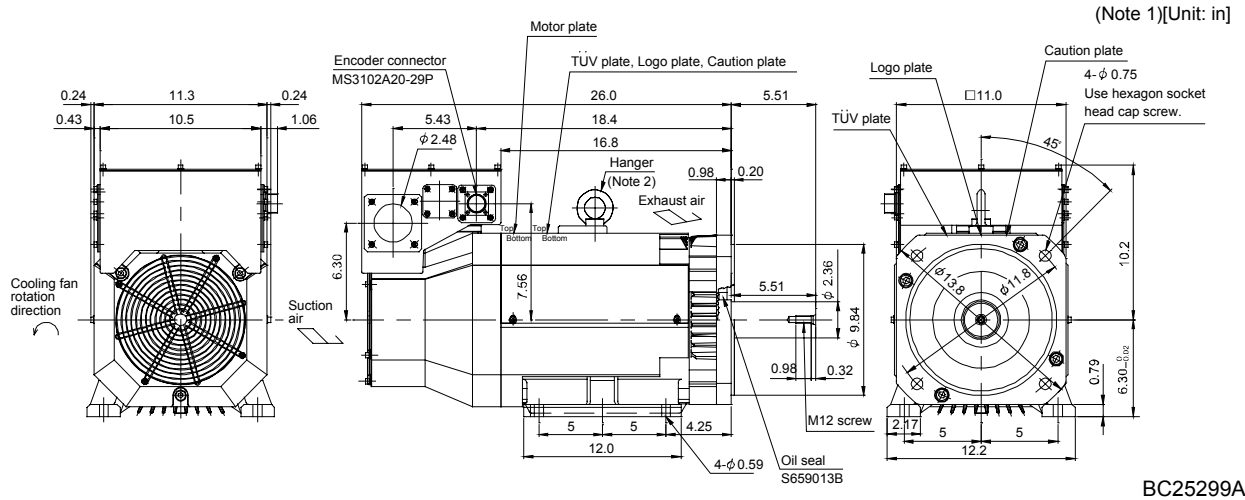

BC25299A

Note 1. The dimensions without tolerances are reference dimensions.
 2. When the motor is used without the hanger, plug the threaded hole with a bolt of M16 X 20 mm or less.

Model	Output [kW]	Inertia Moment WK ² [oz · in ²]	Mass [lb]
HA-LFS30K2	30	3007.1	352.74

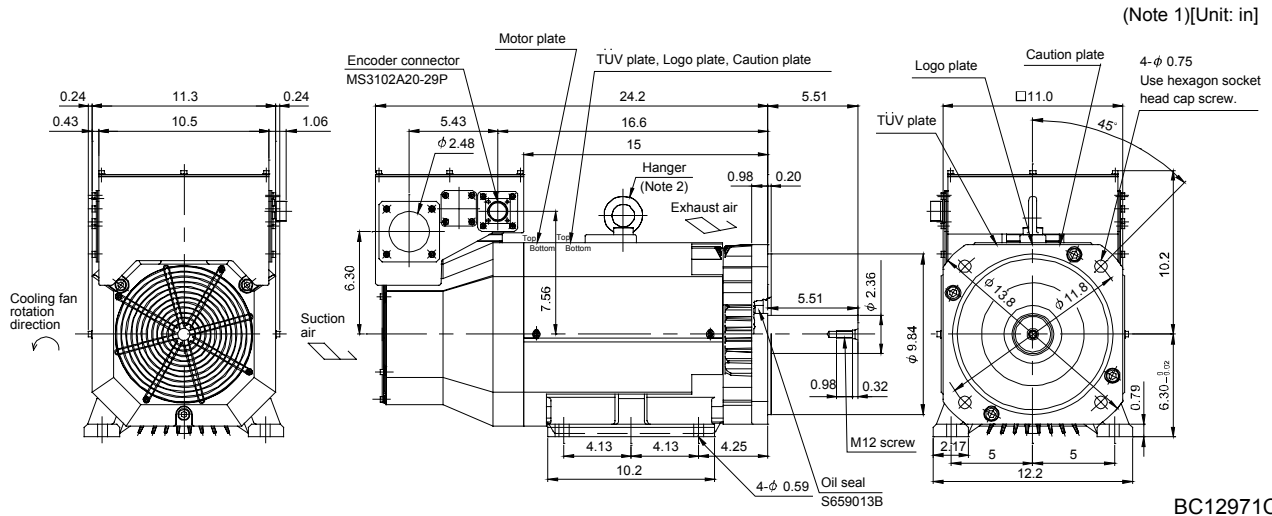

BC12971C

Note 1. The dimensions without tolerances are reference dimensions.
 2. When the motor is used without the hanger, plug the threaded hole with a bolt of M16 X 20 mm or less.

7. OUTLINE DIMENSION DRAWINGS

(2) With electromagnetic brake

Model	Output [kW]	Brake static friction torque [oz · in]	Inertia Moment WK^2 [oz · in ²]	Mass [lb]
HA-LFS601B HA-LFS6014B	6	11612	617.82	154.32
HA-LFS701MB HA-LFS701M4B	7			
HA-LFS11K2B HA-LFS11K24B	11			

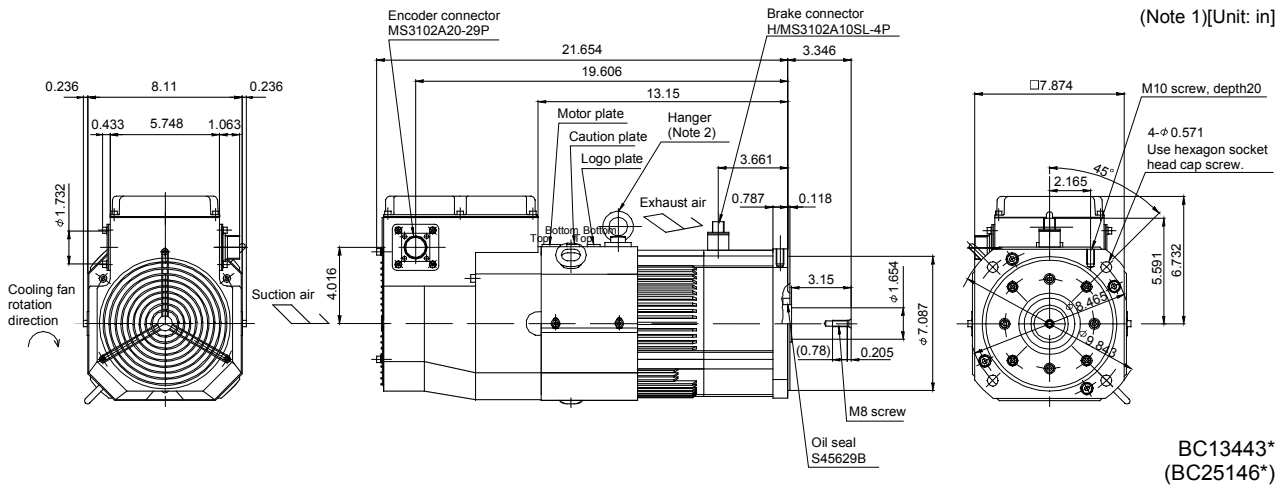

Note 1. The dimensions without tolerances are reference dimensions.
2. When the motor is used without the hanger, plug the threaded hole with a bolt of M10 X 20 mm or less.

Model	Output [kW]	Variable dimensions [in]	Brake static friction torque [oz · in]	Inertia Moment WK^2 [oz · in ²]	Mass [lb]
		L			
HA-LFS801B HA-LFS8014B	8	24.02	22729	1601.96	277.78
HA-LFS11K1MB HA-LFS11K1M4B	11				
HA-LFS15K2B HA-LFS15K24B	15				
HA-LFS12K1B HA-LFS12K14B	12	26.38	2017.49	321.88	
HA-LFS15K1MB HA-LFS15K1M4B	15				
HA-LFS22K2B HA-LFS22K24B	22				

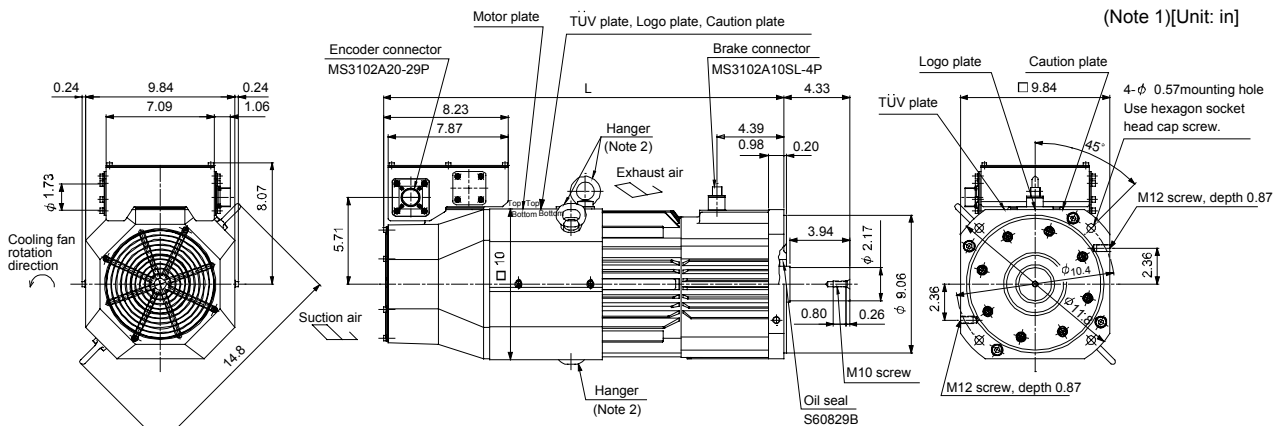

Note 1. The dimensions without tolerances are reference dimensions.
2. When the motor is used without the hanger, plug the threaded hole with a bolt of M16 X 20 mm or less.

7. OUTLINE DIMENSION DRAWINGS

7.2.14 HC-LFS series

(1) Standard (without electromagnetic brake)

Model	Output [kW]	Inertia Moment WK ² [oz · in ²]	Mass [lb]
HC-LFS52	0.5	17.5	14.33

[Unit: in]

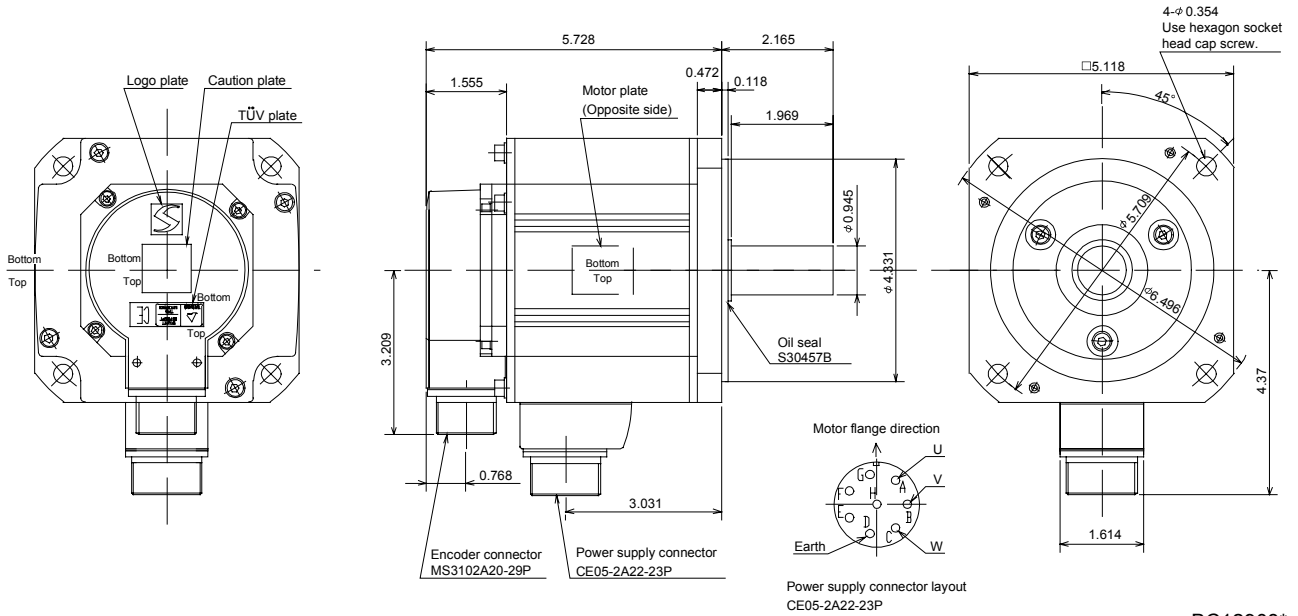

BC12908*

Model	Output [kW]	Inertia Moment WK ² [oz · in ²]	Mass [lb]
HC-LFS102	1.0	25.15	17.64

[Unit: in]

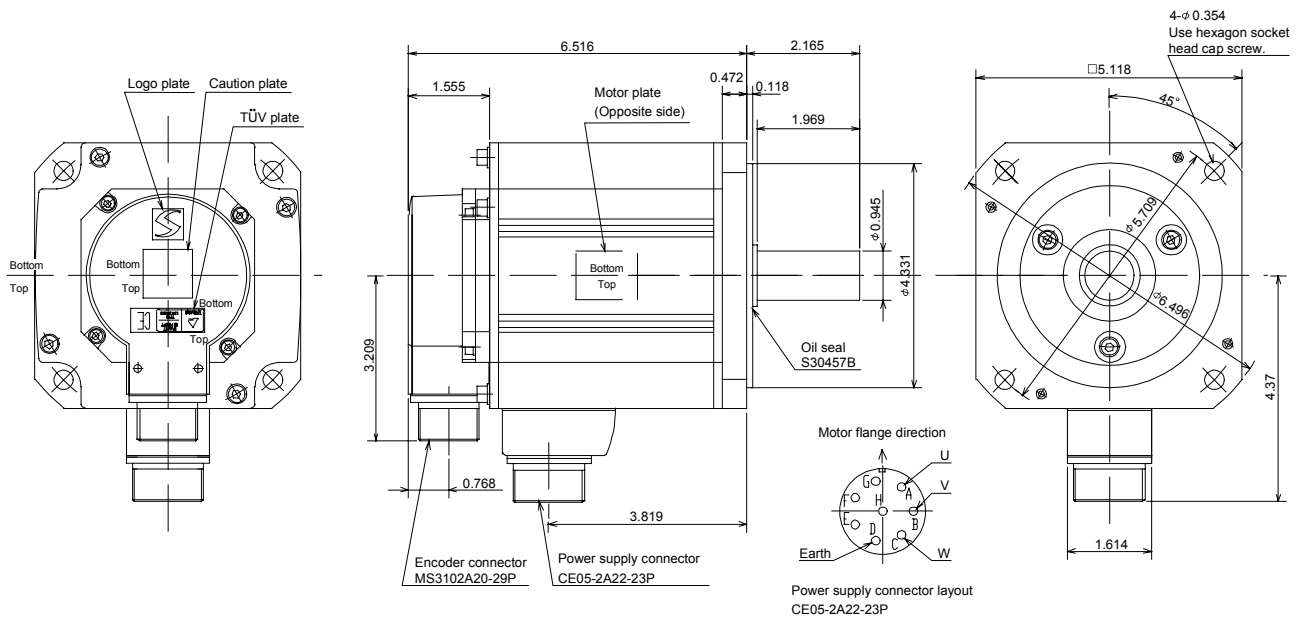

BC12909*

7. OUTLINE DIMENSION DRAWINGS

Model	Output [kW]	Inertia Moment WK^2 [oz · in ²]	Mass [lb]
HC-LFS152	1.5	34.99	22.05

[Unit: in]

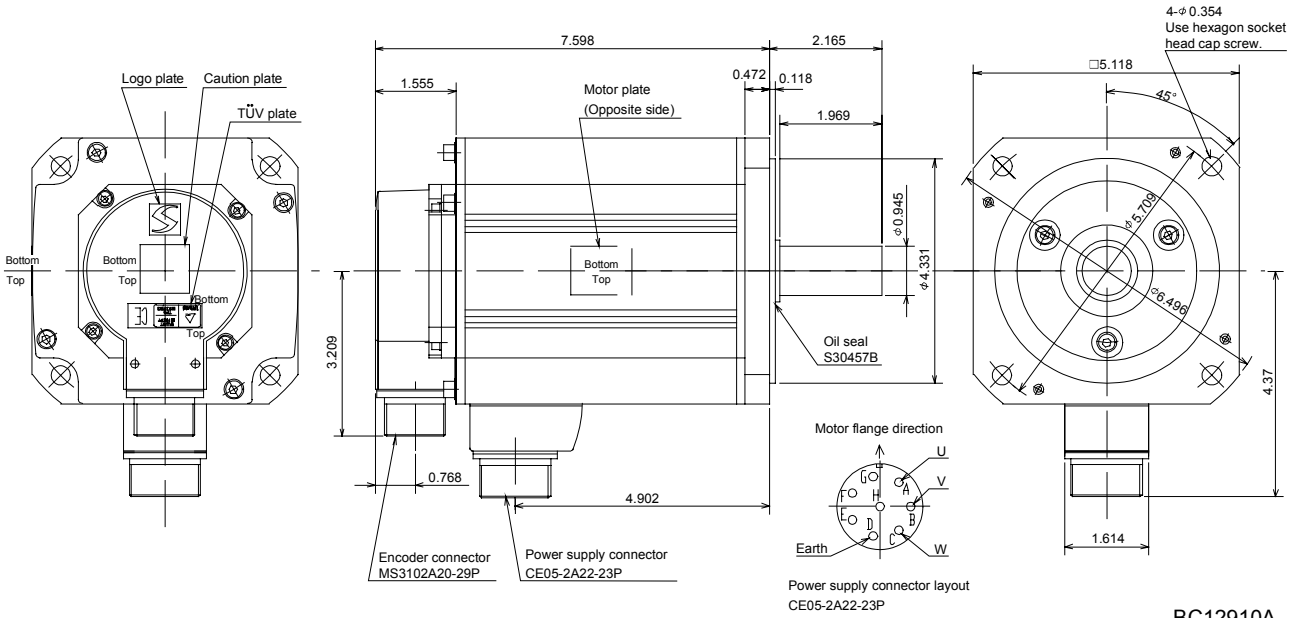

Model	Output [kW]	Inertia Moment WK^2 [oz · in ²]	Mass [lb]
HC-LFS202	2.0	120.28	46.3

[Unit: in]

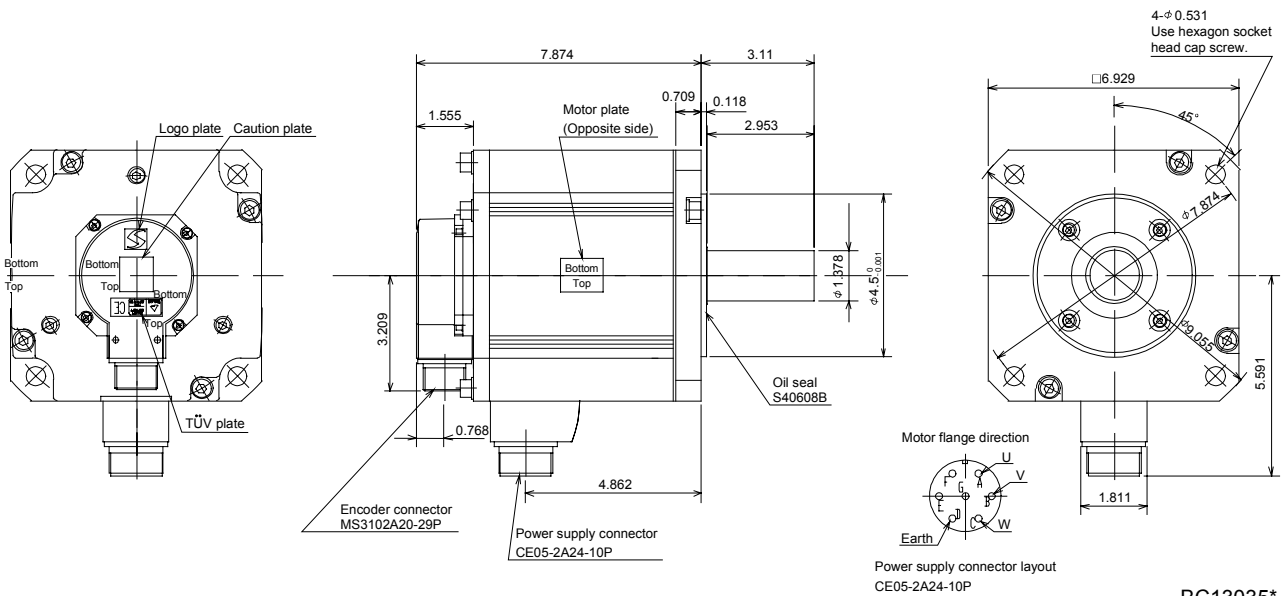

7. OUTLINE DIMENSION DRAWINGS

Model	Output [kW]	Inertia Moment WK^2 [oz · in ²]	Mass [lb]
HC-LFS302	3.0	196.83	61.73

[Unit: in]

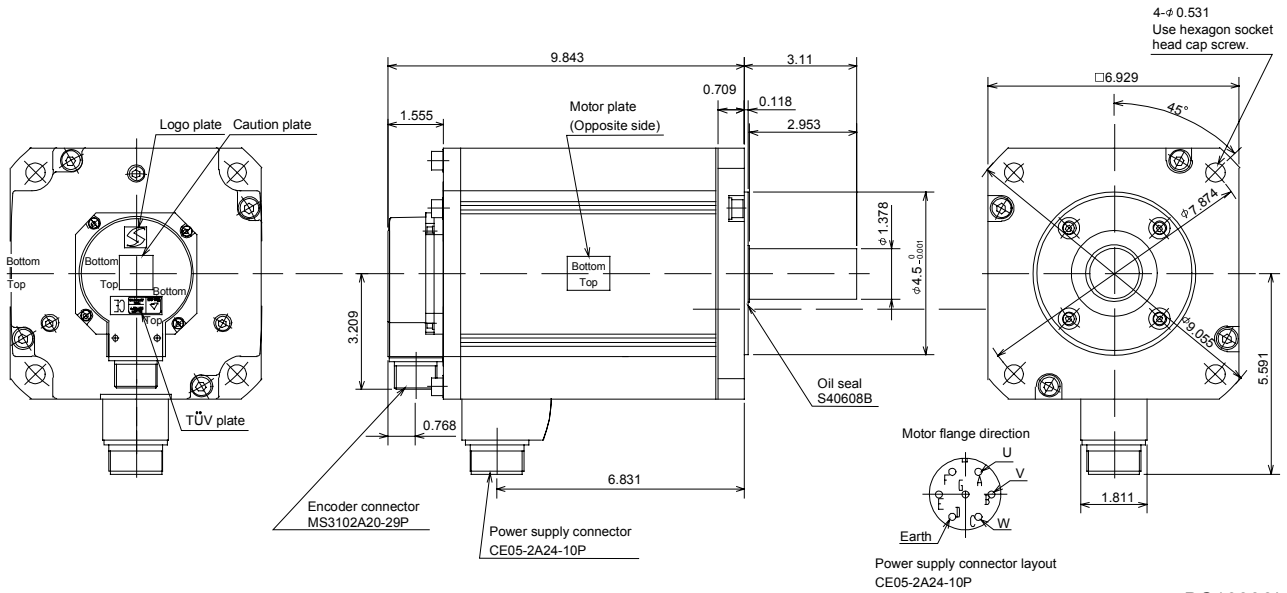

BC13036*

Model	Output [kW]	Inertia Moment WK^2 [oz · in ²]	Mass [lb]	Brake static friction torque [N · m]
HC-LFS52B	0.5	28.43	19.84	8.3

[Unit: in]

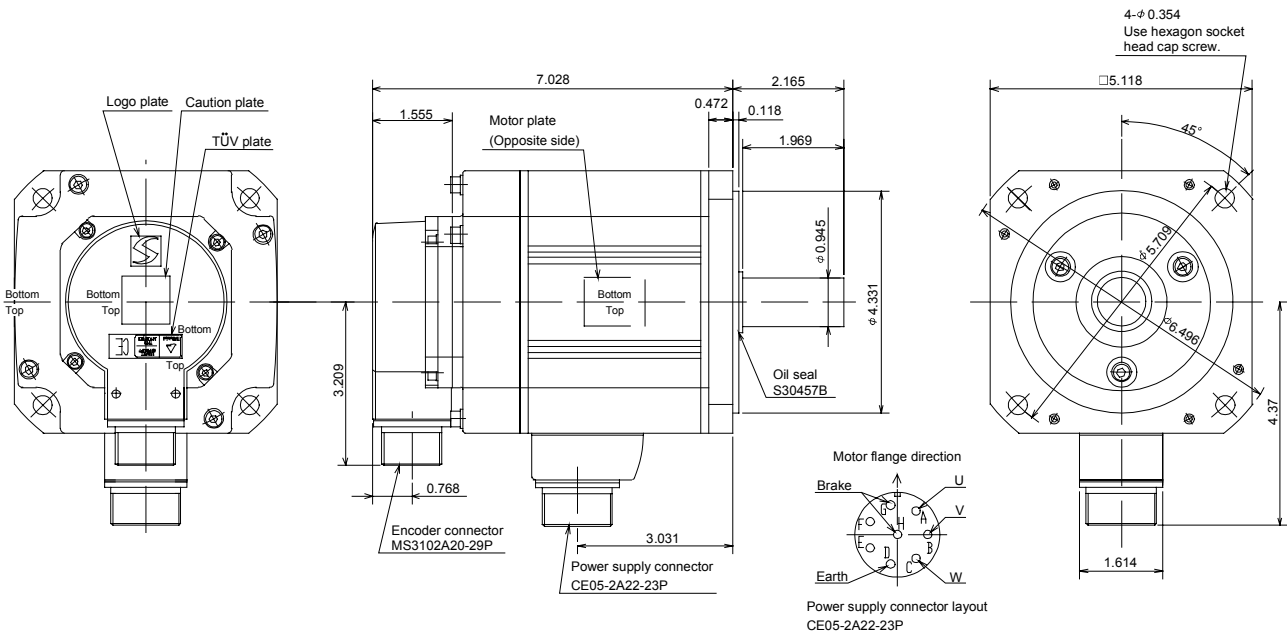

BC12984*

7. OUTLINE DIMENSION DRAWINGS

Model	Output [kW]	Inertia Moment WK^2 [oz · in ²]	Mass [lb]	Brake static friction torque [N · m]
HC-LFS102B	1.0	36.09	23.15	8.3

[Unit: in]

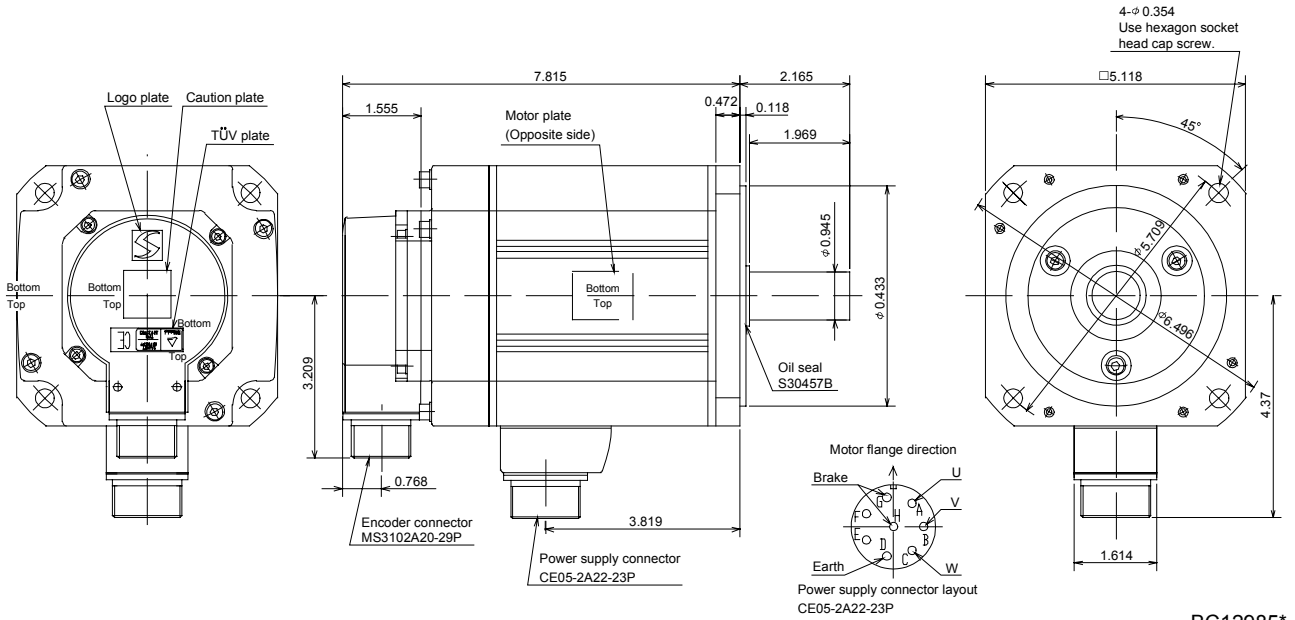

BC12985*

Model	Output [kW]	Inertia Moment WK^2 [oz · in ²]	Mass [lb]	Brake static friction torque [N · m]
HC-LFS152B	1.5	45.93	27.56	8.3

[Unit: in]

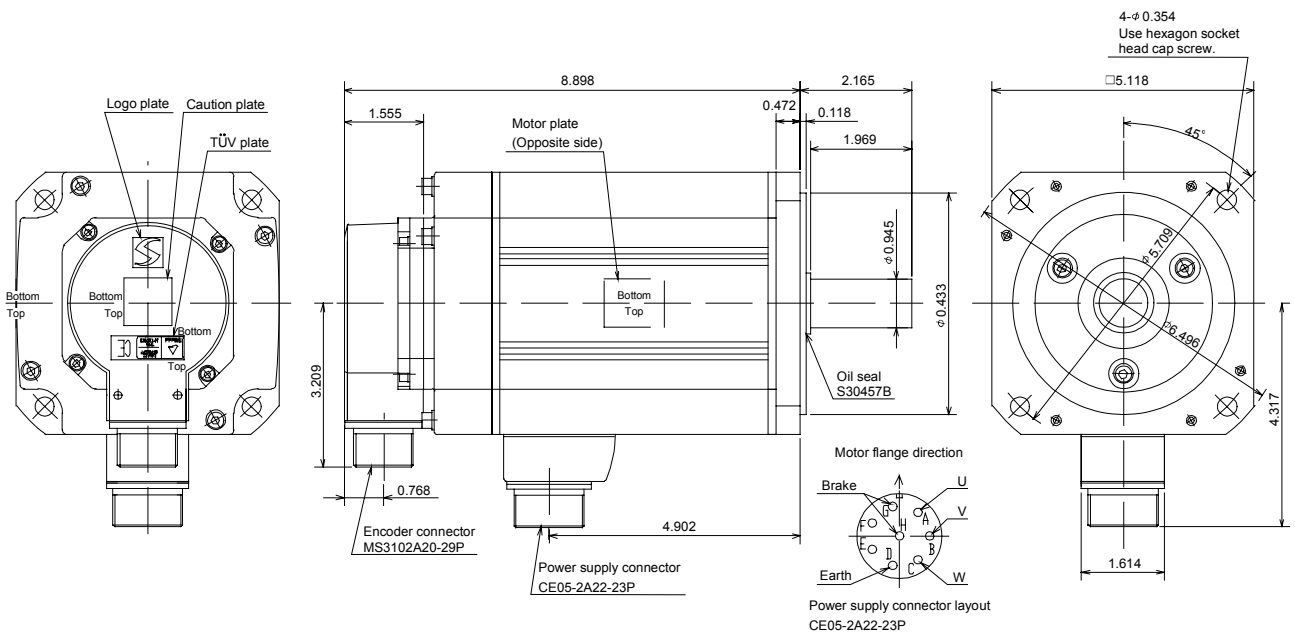

BC12986*

7. OUTLINE DIMENSION DRAWINGS

Model	Output [kW]	Inertia Moment WK^2 [oz · in ²]	Mass [lb]	Brake static friction torque [N · m]
HC-LFS202B	2.0	174.96	59.53	43.1

[Unit: in]

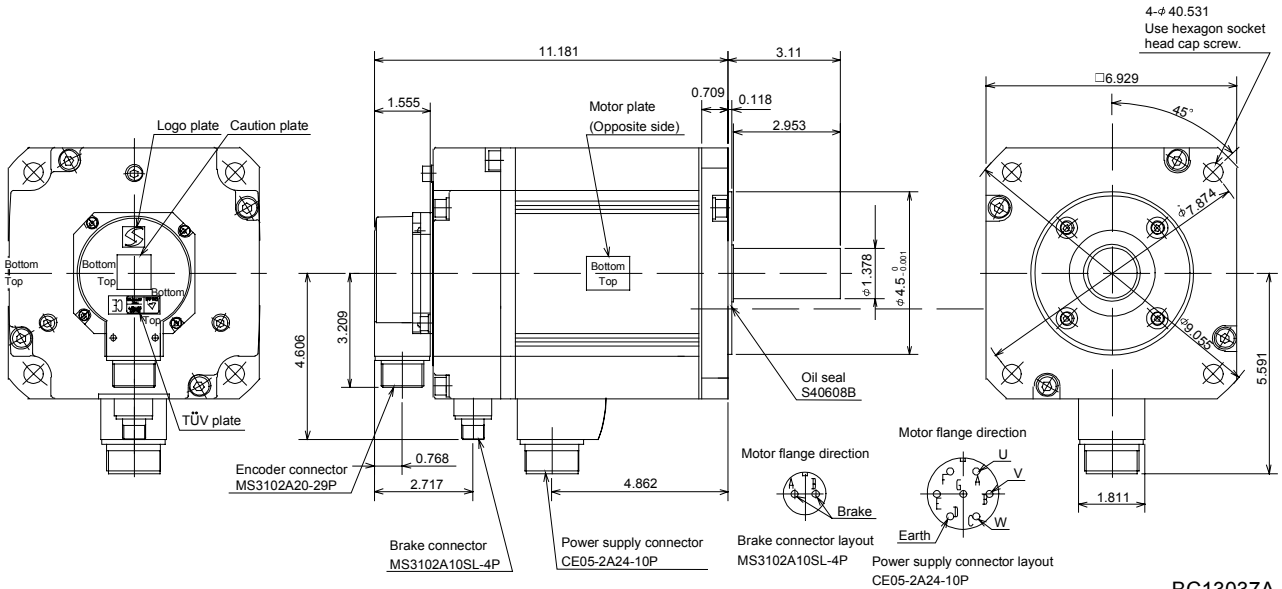

BC13037A

Model	Output [kW]	Inertia Moment WK^2 [oz · in ²]	Mass [lb]	Brake static friction torque [N · m]
HC-LFS302B	3.0	251.5	74.96	43.1

[Unit: in]

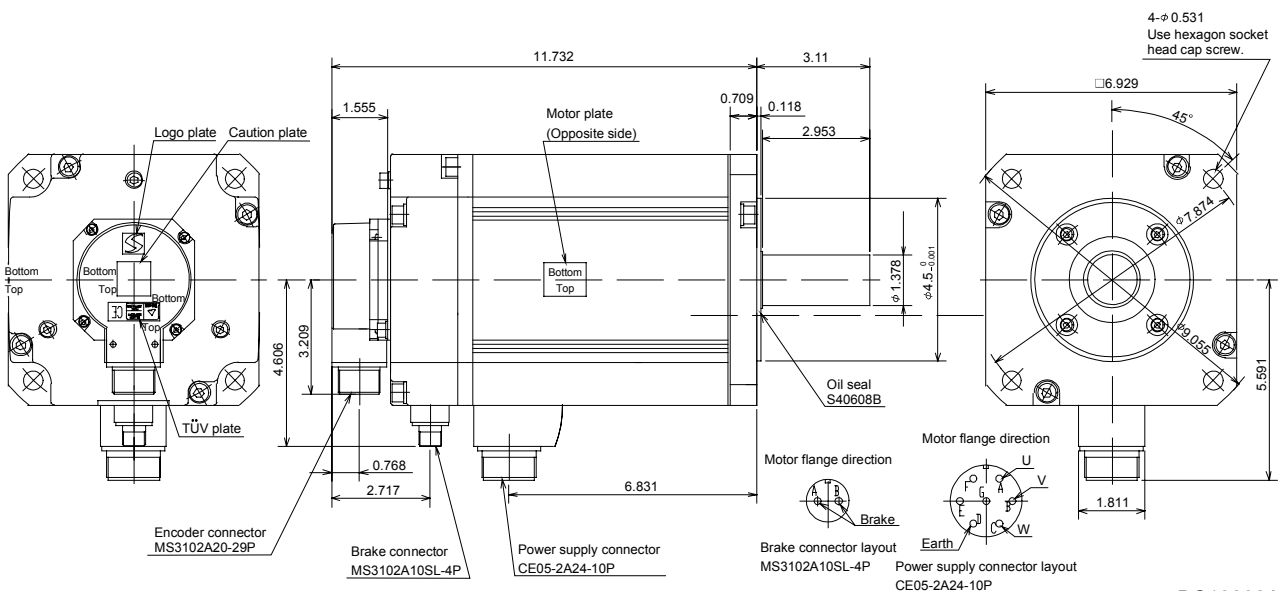

BC13038A

7. OUTLINE DIMENSION DRAWINGS

7.3 Connector

(1) Coupler type

<AMP>

Model

Housing : 1-172161-9

Connector pin : 170359-1 • 170363-1 (loose piece)

Crimping tool : 755330-1

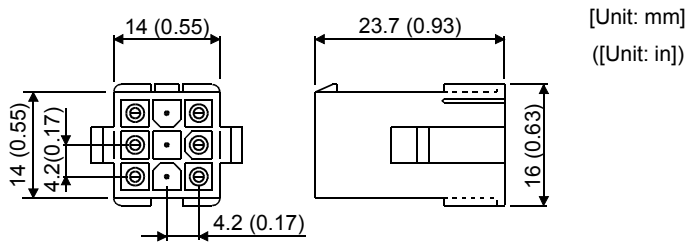

(2) Cannon connector type

(a) Connectors

<DDK>

CE05-6A14S-2SD-D

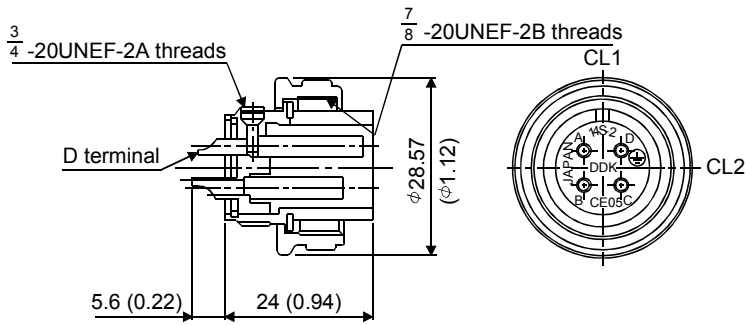

[Unit: mm]
([Unit: in])

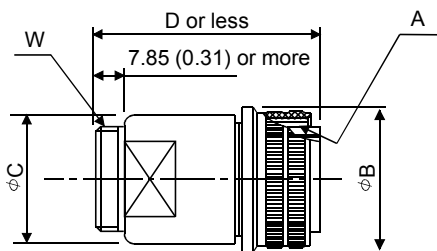

[Unit: mm]
([Unit: in])

Model	A	B	C	D	W
CE05-6A22-23SD-D-BSS	1 3/8-18UNEF-2B	40.48 (1.59)	38.3 (1.51)	61 (2.40)	1 3/16-18UNEF-2A
CE05-6A24-10SD-D-BSS	1 1/2-18UNEF-2B	43.63 (1.72)	42.0 (1.65)	68 (2.68)	1 7/16-18UNEF-2A
CE05-6A32-17SD-D-BSS	2-18UNS-2B	56.33 (2.22)	54.2 (2.13)	79 (3.11)	1 3/4-18UNS-2A

7. OUTLINE DIMENSION DRAWINGS

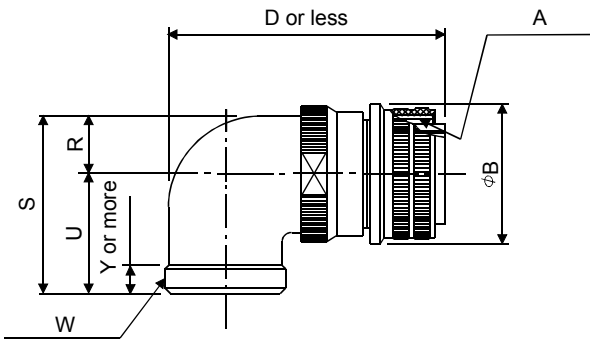

[Unit: mm]
([Unit: in])

Model	A	B	D	W	R	U	S	Y
CE05-8A22-23SD-D-BAS	1 3/8-18UNEF-2B	40.48 (1.59)	75.5 (2.97)	1 3/16-18UNEF-2A	16.3 (0.64)	33.3 (1.31)	49.6 (1.95)	7.5 (0.30)
CE05-8A24-10SD-D-BAS	1 1/2-18UNEF-2B	43.63 (1.72)	86.3 (3.40)	1 7/16-18UNEF-2A	18.2 (0.72)	36.5 (1.44)	54.7 (2.15)	7.5 (0.30)
CE05-8A32-17SD-D-BAS	2-18UNS-2B	56.33 (2.22)	93.5 (3.68)	1 3/4-18UNS-2A	24.6 (0.97)	44.5 (1.75)	61.9 (2.44)	8.5 (0.34)

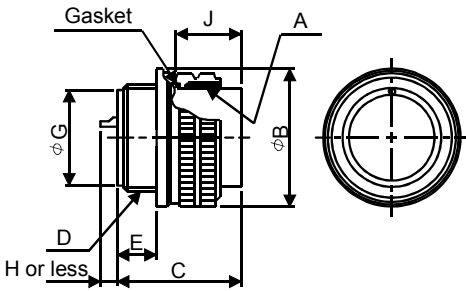

[Unit: mm]
([Unit: in])

Model	A	B	C	D	E	G	J
D/MS3106A10SL-4S(D190)	5/8-24UNEF-2B	22.22 (0.87)	23.3 (0.92)	9/16-24UNEF-2A	7.5 (0.30)	12.5 (0.49)	13.49 (0.53)
D/MS3106A14S-2S(D190)	7/8-20UNEF-2B	28.57 (1.13)	24.34 (0.96)	3/4-20UNEF-2A	8.46 (0.33)	17.0 (0.67)	13.49 (0.53)
D/MS3106A20-29S(D190)	1 1/4-18UNEF-2B	37.28 (1.47)	34.11 (1.34)	1 1/8-18UNEF-2A	12.16 (0.48)	26.8 (1.06)	18.26 (0.72)
D/MS3106A22-23S(D190)	1 3/8-18UNEF-2B	40.48 (1.59)	34.11 (1.34)	1 1/4-18UNEF-2A	12.15 (0.48)	29.9 (1.18)	18.26 (0.72)
D/MS3106A24-10S(D190)	1 1/2-18UNEF-2B	43.63 (1.72)	36.58 (1.44)	1 3/8-18UNEF-2A	13.42 (0.53)	32.9 (1.30)	18.26 (0.72)
D/MS3106A32-17S(D190)	2-18UNS-2B	56.33 (2.22)	36.95 (1.46)	1 7/8-16UN-2A	13.14 (0.52)	45.3 (1.78)	18.26 (0.72)

	Contact Size				
	#16	#12	#8	#4	#0
H	8 or less	8 or less	10 or less	13 or less	13 or less

7. OUTLINE DIMENSION DRAWINGS

[Unit: mm]
([Unit: in])

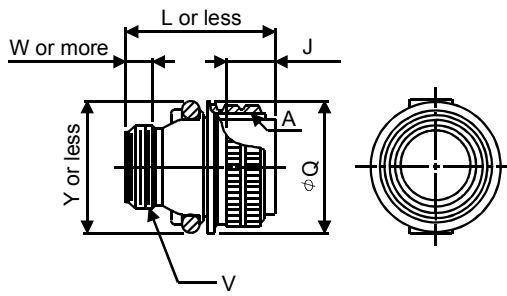

Model	A	J	L	Q	V	W	Y
D/MS3106B14S-2S	7/8-20UNEF	13.49 (0.53)	42.88 (1.69)	28.57 (1.13)	3/4-20UNEF	8.0 (0.32)	30 (1.18)
D/MS3106B20-29S	1 1/4-18UNEF	18.26 (0.72)	55.57 (2.19)	37.28 (1.47)	1 3/16-18UNEF	9.53 (0.38)	47 (1.85)
D/MS3106B22-23S	1 3/8-18UNEF	18.26 (0.72)	55.57 (2.19)	40.48 (1.59)	1 3/16-18UNEF	9.53 (0.38)	50 (1.97)
D/MS3106B24-10S	1 1/2-18UNEF	18.26 (0.72)	58.72 (2.31)	43.63 (1.72)	1 7/16-18UNEF	9.53 (0.38)	53 (2.09)
D/MS3106B32-17S	2-18UNS	18.26 (0.72)	61.92 (2.44)	56.33 (2.22)	1 3/4-18UNS	11.13 (0.44)	66 (2.60)

[Unit: mm]
([Unit: in])

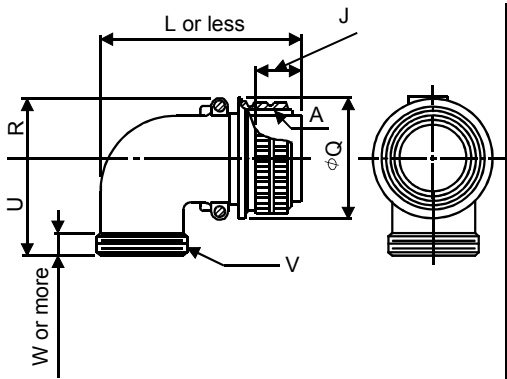

Model	A	J	L	Q	R	U	V	W
D/MS3108B14S-2S	7/8-20UNEF	13.49 (0.53)	53.97 (2.13)	28.57 (1.13)	14.9 (0.59)	27.0 (1.06)	3/4-20UNEF	9.53 (0.38)
D/MS3108B20-29S	1 1/4-18UNEF	18.26 (0.72)	76.98 (3.03)	37.28 (1.47)	22.5 (0.89)	33.3 (1.31)	1 3/16-18UNEF	9.53 (0.38)
D/MS3108B22-23S	1 3/8-18UNEF	18.26 (0.72)	76.98 (3.03)	40.48 (1.59)	24.1 (0.95)	33.3 (1.31)	1 3/16-18UNEF	9.53 (0.38)
D/MS3108B24-10S	1 1/2-18UNEF	18.26 (0.72)	86.51 (3.41)	43.63 (1.72)	25.6 (1.01)	36.5 (1.44)	1 7/16-18UNEF	9.53 (0.38)
D/MS3108B32-17S	2-18UNS	18.26 (0.72)	95.25 (3.75)	56.33 (2.22)	32.8 (1.29)	44.4 (1.75)	1 3/4-18UNS	11.13 (0.44)

(b) Flexible conduit connectors <Daiwa Dengyo>

MSA

MAA

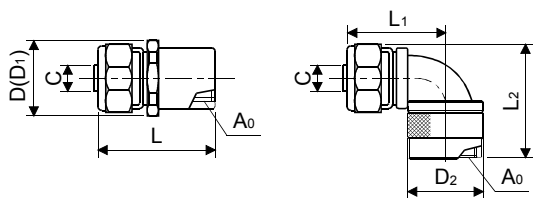

[Unit: mm]
([Unit: in])

Model	A ₀	C	L	L ₁	L ₂	D	D ₁	D ₂
MSA-10-10 • MAA-10-10	9/16-24UNEF-2B	8.2 (0.32)	44 (1.73)	35.5 (1.40)	45 (1.77)	27 (1.06)	29 (1.14)	26 (1.02)
MSA-10-14 • MAA-10-14	3/4-20UNEF-2B	8.2 (0.32)	45 (1.77)	39.5 (1.56)	46 (1.81)	27 (1.06)	29 (1.14)	35 (1.38)
MSA-12-14 • MAA-12-14	3/4-20UNEF-2B	10.7 (0.42)	45 (1.77)	39.5 (1.56)	46 (1.81)	27 (1.06)	29 (1.14)	35 (1.38)
MSA-16-20 • MAA-16-20	1 1/8-18UNEF-2B	14 (0.55)	49.5 (1.95)	47 (1.85)	52 (2.05)	36 (1.42)	38 (1.50)	39 (1.54)
MSA-16-22 • MAA-16-22	1 1/4-18UNEF-2B	14 (0.55)	49.5 (1.95)	47 (1.85)	52 (2.05)	38 (1.50)	42 (1.65)	39 (1.54)
MSA-16-24 • MAA-16-24	1 3/8-18UNEF-2B	14 (0.55)	49.5 (1.95)	51 (2.01)	54 (2.13)	41 (1.61)	43 (1.69)	47 (1.85)
MSA-22-20 • MAA-22-20	1 1/8-18UNEF-2B	18.9 (0.74)	49.5 (1.95)	47 (1.85)	54 (2.13)	36 (1.42)	39 (1.54)	39 (1.54)
MSA-22-22 • MAA-22-22	1 1/4-18UNEF-2B	18.9 (0.74)	49.5 (1.95)	47 (1.85)	54 (2.13)	38 (1.50)	42 (1.65)	39 (1.54)
MSA-22-24 • MAA-22-24	1 3/8-18UNEF-2B	18.9 (0.74)	49.5 (1.95)	51 (2.01)	56 (2.21)	41 (1.61)	43 (1.69)	47 (1.85)
MSA-28-22 • MAA-28-22	1 1/4-18UNEF-2B	24.5 (0.97)	51 (2.01)	53 (2.09)	64 (2.52)	46 (1.81)	50 (1.97)	47 (1.85)
MSA-28-24 • MAA-28-24	1 3/8-18UNEF-2B	24.5 (0.97)	51 (2.01)	53 (2.09)	66 (2.60)	46 (1.81)	50 (1.97)	47 (1.85)

7. OUTLINE DIMENSION DRAWINGS

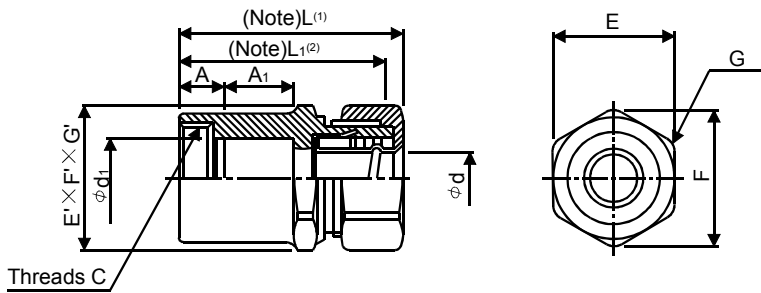

[Unit: mm]
[Unit: in]

Model	Threads C	A	A ₁	d	d ₁	Jam Nut			Lock Nut			L	L ₁
						E Width Across Flats	F Width Across Corners	G Number Of Corners	E' Width Across Flats	F' Width Across Corners	G' Number Of Corners		
RCC-102RL-MS10F	9/16-24UNEF-2B	6 (0.24)	15 (0.59)	8.3 (0.33)	11.0 (0.43)	24 (0.95)	26.4 (1.04)	6	24 (0.95)	26.4 (1.04)	6	39 (1.54)	36 (1.42)
RCC-102RL-MS14F	3/4-20UNEF-2B	7 (0.28)	15 (0.59)	8.3 (0.33)	15.0 (0.59)	24 (0.95)	26.4 (1.04)	6	24 (0.95)	26.4 (1.04)	6	40 (1.58)	37 (1.46)
RCC-103RL-MS14F	3/4-20UNEF-2B	7 (0.28)	15 (0.59)	10.6 (0.42)	15.0 (0.59)	27 (1.06)	29.7 (1.17)	6	26 (1.02)	28.6 (1.13)	6	44 (1.73)	41 (1.61)
RCC-104RL-MS14F	3/4-20UNEF-2B	7 (0.28)	15 (0.59)	14.0 (0.55)	15.0 (0.59)	30 (1.18)	33.0 (1.30)	6	30 (1.18)	33.0 (1.30)	6	45 (1.77)	42 (1.65)
RCC-104RL-MS20F	1 1/8-18UNEF-2B	9 (0.35)	15 (0.59)	14.0 (0.55)	24.0 (0.95)	30 (1.18)	33.0 (1.30)	6	32 (1.26)	35.2 (1.39)	6	47 (1.85)	44 (1.73)
RCC-104RL-MS22F	1 1/4-18UNEF-2B	9 (0.35)	15 (0.59)	14.0 (0.55)	27.0 (1.06)	30 (1.18)	33.0 (1.30)	6	36 (1.42)	39.6 (1.56)	6	47 (1.85)	44 (1.73)
RCC-104RL-MS24F	1 3/8-18UNEF-2B	10 (0.39)	20 (0.79)	14.0 (0.55)	30.0 (1.18)	30 (1.18)	33.0 (1.30)	6	40 (1.58)	42.5 (1.67)	8	54 (2.13)	50 (1.97)
RCC-106RL-MS20F	1 1/8-18UNEF-2B	9 (0.35)	15 (0.59)	19.0 (0.75)	24.0 (0.95)	37 (1.46)	40.7 (1.60)	6	36 (1.42)	39.6 (1.56)	6	50 (1.97)	46 (1.81)
RCC-106RL-MS22F	1 1/4-18UNEF-2B	9 (0.35)	15 (0.59)	19.0 (0.75)	27.0 (1.06)	37 (1.46)	40.7 (1.60)	6	36 (1.42)	39.6 (1.56)	6	50 (1.97)	46 (1.81)
RCC-106RL-MS24F	1 3/8-18UNEF-2B	10 (0.39)	20 (0.79)	19.0 (0.75)	30.0 (1.18)	37 (1.46)	40.7 (1.60)	6	40 (1.58)	42.5 (1.67)	8	56 (2.21)	52 (2.05)
RCC-106RL-MS32F	1 7/8-16UN-2B	11 (0.43)	20 (0.79)	19.0 (0.75)	42.5 (1.67)	37 (1.46)	40.7 (1.60)	6	52 (2.05)	54.5 (2.15)	8	57 (2.24)	53 (2.09)
RCC-108RL-MS22F	1 1/4-18UNEF-2B	9 (0.35)	15 (0.59)	24.4 (0.96)	27.0 (1.06)	45 (1.77)	47.3 (1.86)	8	44 (1.73)	46.3 (1.82)	8	55 (2.17)	50 (1.97)
RCC-108RL-MS24F	1 3/8-18UNEF-2B	10 (0.39)	20 (0.79)	24.4 (0.96)	30.0 (1.18)	45 (1.77)	47.3 (1.86)	8	44 (1.73)	46.3 (1.82)	8	60 (2.36)	55 (2.17)
RCC-108RL-MS32F	1 7/8-16UN-2B	11 (0.43)	20 (0.79)	24.4 (0.96)	42.5 (1.67)	45 (1.77)	47.3 (1.86)	8	52 (2.05)	54.5 (2.15)	8	61 (2.40)	56 (2.21)

Note: (1) indicates the reference dimension before assembling, and (2) the reference dimension after assembling.

7. OUTLINE DIMENSION DRAWINGS

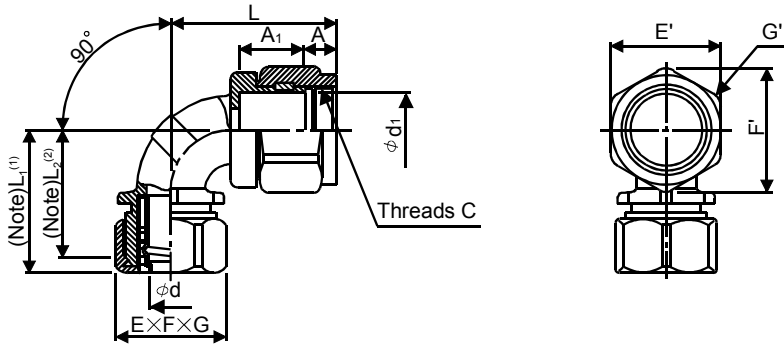

[Unit: mm]
([Unit: in])

Model	Threads C	A	A ₁	d	d ₁	Jam Nut			Lock Nut			L	L ₁	L ₂
						E Width Across Flats	F Width Across Corners	G Number Of Corners	E' Width Across Flats	F' Width Across Corners	G' Number Of Corners			
RCC-302RL-MS10F	9/16-24UNEF-2B	6 (0.24)	15 (0.59)	8.3 (0.33)	10.0 (0.39)	24 (0.95)	26.4 (1.04)	6	20 (0.79)	22.0 (0.87)	6	35 (1.38)	33 (1.30)	30 (1.18)
RCC-302RL-MS14F	3/4-20UNEF-2B	7 (0.28)	15 (0.59)	8.3 (0.33)	13.8 (0.54)	24 (0.95)	26.4 (1.04)	6	23 (0.91)	25.3 (1.0)	6	35 (1.38)	33 (1.30)	30 (1.18)
RCC-303RL-MS14F	3/4-20UNEF-2B	7 (0.28)	15 (0.59)	10.6 (0.42)	13.8 (0.54)	27 (1.06)	29.7 (1.17)	6	23 (0.91)	25.3 (1.0)	6	37 (1.46)	37 (1.46)	34 (1.34)
RCC-304RL-MS14F	3/4-20UNEF-2B	7 (0.28)	15 (0.59)	14.0 (0.55)	13.8 (0.54)	30 (1.18)	33.0 (1.30)	6	23 (0.91)	25.3 (1.0)	6	39 (1.54)	38 (1.50)	35 (1.38)
RCC-304RL-MS20F	1 1/8-18UNEF-2B	9 (0.35)	15 (0.59)	14.0 (0.55)	23.2 (0.91)	30 (1.18)	33.0 (1.30)	6	32 (1.26)	35.2 (1.39)	6	41 (1.61)	38 (1.50)	35 (1.38)
RCC-304RL-MS22F	1 1/4-18UNEF-2B	9 (0.35)	15 (0.59)	14.0 (0.55)	26.5 (1.04)	30 (1.18)	33.0 (1.30)	6	36 (1.42)	39.6 (1.56)	6	41 (1.61)	38 (1.50)	35 (1.38)
RCC-304RL-MS24F	1 3/8-18UNEF-2B	10 (0.39)	20 (0.79)	14.0 (0.55)	28.7 (1.13)	30 (1.18)	33.0 (1.30)	6	40 (1.58)	42.5 (1.67)	8	47 (1.85)	46 (1.81)	43 (1.69)
RCC-306RL-MS20F	1 1/8-18UNEF-2B	9 (0.35)	15 (0.59)	19.0 (0.75)	23.2 (0.91)	37 (1.46)	40.7 (1.60)	6	32 (1.26)	35.2 (1.39)	6	45 (1.77)	44 (1.73)	40 (1.58)
RCC-306RL-MS22F	1 1/4-18UNEF-2B	9 (0.35)	15 (0.59)	19.0 (0.75)	26.5 (1.04)	37 (1.46)	40.7 (1.60)	6	36 (1.42)	39.6 (1.56)	6	45 (1.77)	44 (1.73)	40 (1.58)
RCC-306RL-MS24F	1 3/8-18UNEF-2B	10 (0.39)	20 (0.79)	19.0 (0.75)	28.7 (1.13)	37 (1.46)	40.7 (1.60)	6	40 (1.58)	42.5 (1.67)	8	51 (2.01)	49 (1.93)	45 (1.77)
RCC-306RL-MS32F	1 7/8-16UN-2B	11 (0.43)	20 (0.79)	19.0 (0.75)	40.6 (1.60)	37 (1.46)	40.7 (1.60)	6	54 (2.13)	56.7 (2.23)	8	52 (2.05)	49 (1.93)	45 (1.77)
RCC-308RL-MS22F	1 1/4-18UNEF-2B	9 (0.35)	15 (0.59)	24.4 (0.96)	26.5 (1.04)	45 (1.77)	47.3 (1.86)	8	36 (1.42)	39.6 (1.56)	6	49 (1.93)	50 (1.97)	45 (1.77)
RCC-308RL-MS24F	1 3/8-18UNEF-2B	10 (0.39)	20 (0.79)	24.4 (0.96)	28.7 (1.13)	45 (1.77)	47.3 (1.86)	8	40 (1.58)	42.5 (1.67)	8	56 (2.21)	50 (1.97)	45 (1.77)
RCC-308RL-MS32F	1 7/8-16UN-2B	11 (0.43)	20 (0.79)	24.4 (0.96)	40.6 (1.60)	45 (1.77)	47.3 (1.86)	8	54 (2.13)	56.7 (2.23)	8	62 (2.44)	50 (1.97)	45 (1.77)

Note: (1) indicates the reference dimension before assembling, and (2) the reference dimension after assembling.

(c) Back shell
<DDK>

CE02-20BS-S-D

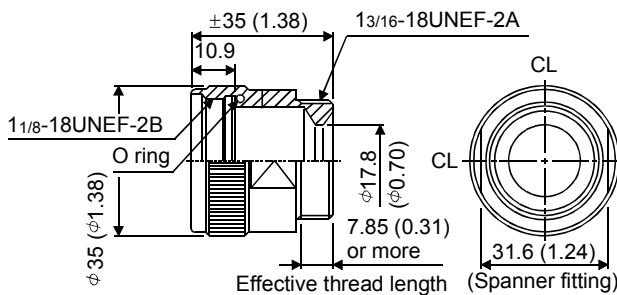

CE-20BA-S-D

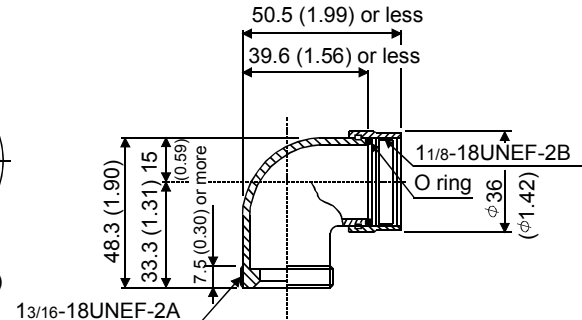

7. OUTLINE DIMENSION DRAWINGS

(d) Cable clamps <DDK>

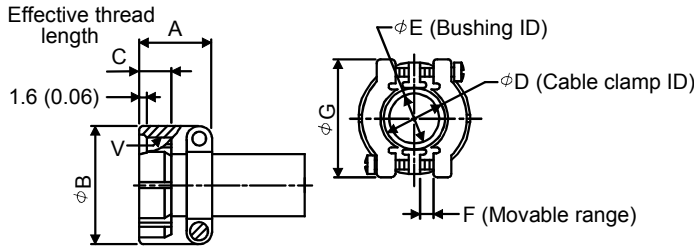

[Unit: mm]
([Unit: in])

Model	Shell Size	A	B	C	D	E	F	G	V	Bushing
D/MS3057-6A	14S	22.2 (0.87)	24.6 (0.97)	10.3 (0.41)	11.2 (0.44)	7.9 (0.31)	2.0 (0.08)	27.0 (1.06)	3/4-20UNEF	AN3420-6
D/MS3057-12A	20 • 22	23.8 (0.94)	35.0 (1.38)	10.3 (0.41)	19.0 (0.75)	15.9 (0.63)	4.0 (0.16)	37.3 (1.47)	1 3/16-18UNEF	AN3420-12
D/MS3057-16A	24 • 28	26.2 (1.03)	42.1 (1.66)	10.3 (0.41)	23.8 (0.94)	15.9 (0.63) 19.1 (0.75)	4.8 (0.19)	42.9 (1.69)	1 7/16-18UNEF	AN3420-12 AN3420-16
D/MS3057-20A	32	27.8 (1.09)	51.6 (2.03)	11.9 (0.47)	31.7 (1.25)	19.1 (0.75) 23.8 (0.94)	6.3 (0.25)	51.6 (2.03)	1 3/4-18UNS	AN3420-16 AN3420-20

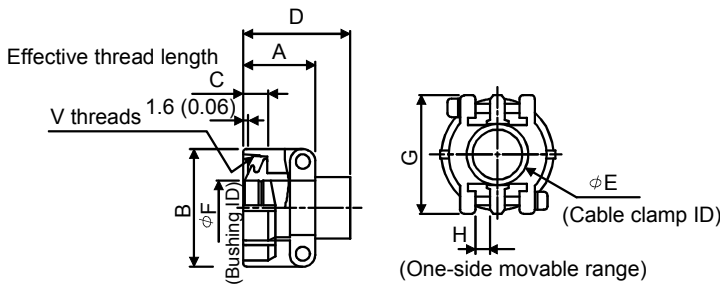

[Unit: mm]
([Unit: in])

Model	Shell Size	A	B	C	D	E	F	G	H	V	Bushing	Cable Range
CE3057-12A-1-D	20 • 22	23.8 (0.94)	35.0 (1.38)	10.3 (0.41)	41.3 (1.63)	19.0 (0.75)	16 (0.63)	37.3 (1.47)	4 (0.16)	1 3/16-18UNEF-2B	CE3420-12-1	$\phi 12.5$ to $\phi 16$
13 (0.51)							CE3420-12-2				$\phi 9.5$ to $\phi 13$	
10 (0.39)							CE3420-12-3				$\phi 6.8$ to $\phi 10$	
CE3057-16A-1-D	24	26.2 (1.03)	42.1 (1.66)	10.3 (0.41)	41.3 (1.63)	23.8 (0.94)	19.1 (0.75)	42.9 (1.69)	4.8 (0.19)	1 7/16-18UNEF-2B	CE3420-16-1	$\phi 15$ to $\phi 19.1$
15.5 (0.61)							CE3420-16-2				$\phi 13$ to $\phi 15.5$	
CE3057-20A-1-D	32	27.8 (1.09)	51.6 (2.03)	11.9 (0.47)	43 (1.69)	31.7 (1.25)	23.8 (0.94)	51.6 (2.03)	6.3 (0.25)	1 3/4-18UNS-2B	CE3420-20-1	$\phi 22$ to $\phi 23.8$

<Daiwa Dengyo>

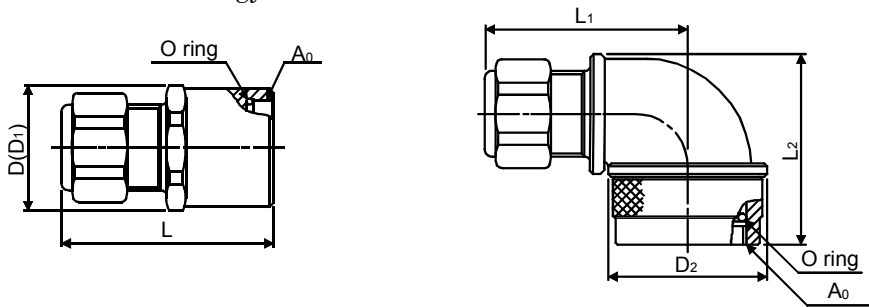

[Unit: mm]
([Unit: in])

Model	Acceptable OD	A_0	L	L_1	L_2	D	D_1	D_2
YSO10-5 to 8 • YLO10-5 to 8	$\phi 5$ to 8.3 ($\phi 0.20$ to 0.33)	9/16-24UNEF-2B	43 (1.69)	39 (1.54)	42.5 (1.67)	24 (0.94)	26 (1.02)	26 (1.02)
YSO14-5 to 8 • YLO14-5 to 8	$\phi 5$ to 8.3 ($\phi 0.20$ to 0.33)	3/4-20UNEF-2B	44 (1.73)	43.5 (1.71)	44.5 (1.75)	26 (1.02)	28 (1.10)	35 (1.38)
YSO14-9 to 11 • YLO14-9 to 11	$\phi 8.3$ to 11.3 ($\phi 0.33$ to 0.45)							

7. OUTLINE DIMENSION DRAWINGS

<Nippon Flex>

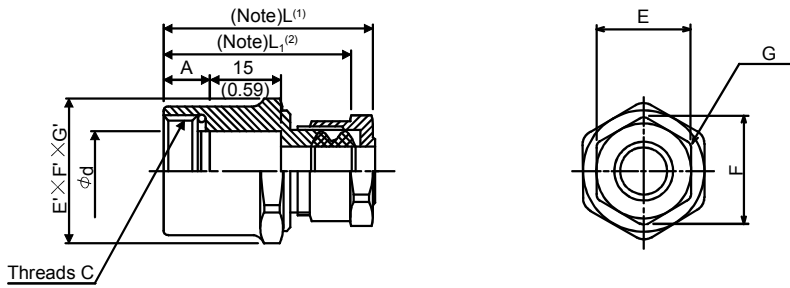

[Unit: mm]
([Unit: in])

Model	Threads C	Applicable Cable Diameter	A	d	Tightening Nut			Nipple Body			L	L ₁
					E Width Across Flats	F Width Across Corners	G Number Of Corners	E' Width Across Flats	F' Width Across Corners	G' Number Of Corners		
ACS-08RL- MS10F	9/16-24UNEF-2B	φ4.0 to φ8.0 (φ0.16 to 0.32)	6 (0.24)	11.0 (0.43)	20 (0.79)	22.0 (0.87)	6	20 (0.79)	22.0 (0.87)	6	45 (1.77)	40 (1.57)
ACS-08RL- MS14F	3/4-20UNEF-2B	φ4.0 to φ8.0 (φ0.16 to 0.32)	7 (0.28)	15.0 (0.59)	20 (0.79)	22.0 (0.87)	6	22 (0.87)	24.2 (0.95)	6	46 (1.81)	41 (1.61)
ACS-12RL- MS10F	9/16-20UNEF-2B	φ8.0 to φ12.0 (φ0.32 to 0.47)	6 (0.24)	11.0 (0.43)	24 (0.94)	26.4 (1.04)	6	24 (0.94)	26.4 (1.04)	6	46 (1.81)	41 (1.61)
ACS-12RL- MS14F	3/4-20UNEF-2B	φ8.0 to φ12.0 (φ0.32 to 0.47)	7 (0.28)	15.0 (0.59)	24 (0.94)	26.4 (1.04)	6	36 (1.42)	28.6 (1.13)	6	46 (1.81)	41 (1.61)

Note: (1) indicates the reference dimension before assembling, and (2) the reference dimension after assembling.

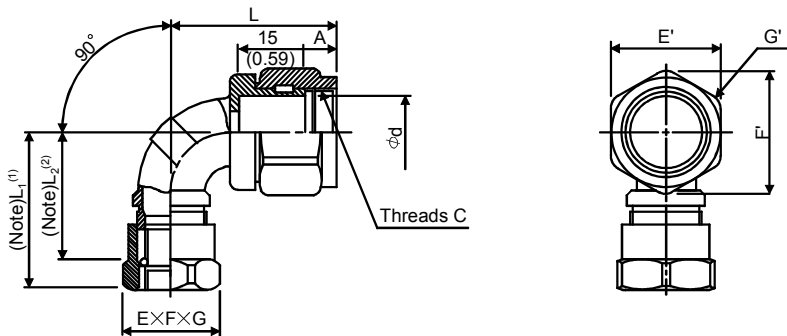

[Unit: mm]
([Unit: in])

Model	Threads C	Applicable Cable Diameter	A	d	Tightening Nut			Nipple Body			L	L ₁	L ₂
					E Width Across Flats	F Width Across Corners	G Number Of Corners	E' Width Across Flats	F' Width Across Corners	G' Number Of Corners			
ACA-08RL- MS10F	9/16-24UNEF-2B	φ4.0 to φ8.0 (φ0.16 to 0.32)	6 (0.24)	10.0 (0.39)	20 (0.79)	22.0 (0.87)	6	20 (0.79)	22.0 (0.87)	6	35 (1.38)	37 (1.46)	32 (1.26)
ACA-08RL- MS14F	3/4-20UNEF-2B	φ4.0 to φ8.0 (φ0.16 to 0.32)	7 (0.28)	13.8 (0.54)	20 (0.79)	22.0 (0.87)	6	23 (0.91)	25.3 (1.00)	6	41 (1.61)	43 (1.69)	38 (1.50)
ACA-12RL- MS10F	9/16-24UNEF-2B	φ8.0 to φ12.0 (φ0.32 to 0.47)	6 (0.24)	10.0 (0.39)	24 (0.94)	26.4 (1.04)	6	20 (0.79)	22.0 (0.87)	6	40 (1.57)	43 (1.69)	38 (1.50)
ACA-12RL- MS14F	3/4-20UNEF-2B	φ8.0 to φ12.0 (φ0.32 to 0.47)	7 (0.28)	13.8 (0.54)	24 (0.94)	26.4 (1.04)	6	23 (0.91)	25.3 (1.00)	6	41 (1.61)	43 (1.69)	38 (1.50)

Note: (1) indicates the reference dimension before assembling, and (2) the reference dimension after assembling.

7. OUTLINE DIMENSION DRAWINGS

(3) Plug

[Unit: mm]
([Unit: in])

Model	Number of Poles	A	B
5509-04P-210	4 (0.16)	4.2 (0.17)	9.6 (0.38)
5559-06P-210	6 (0.24)	8.4 (0.33)	13.8 (0.54)

Terminal : 5558PBT3L
Hand tool : 57022-5300

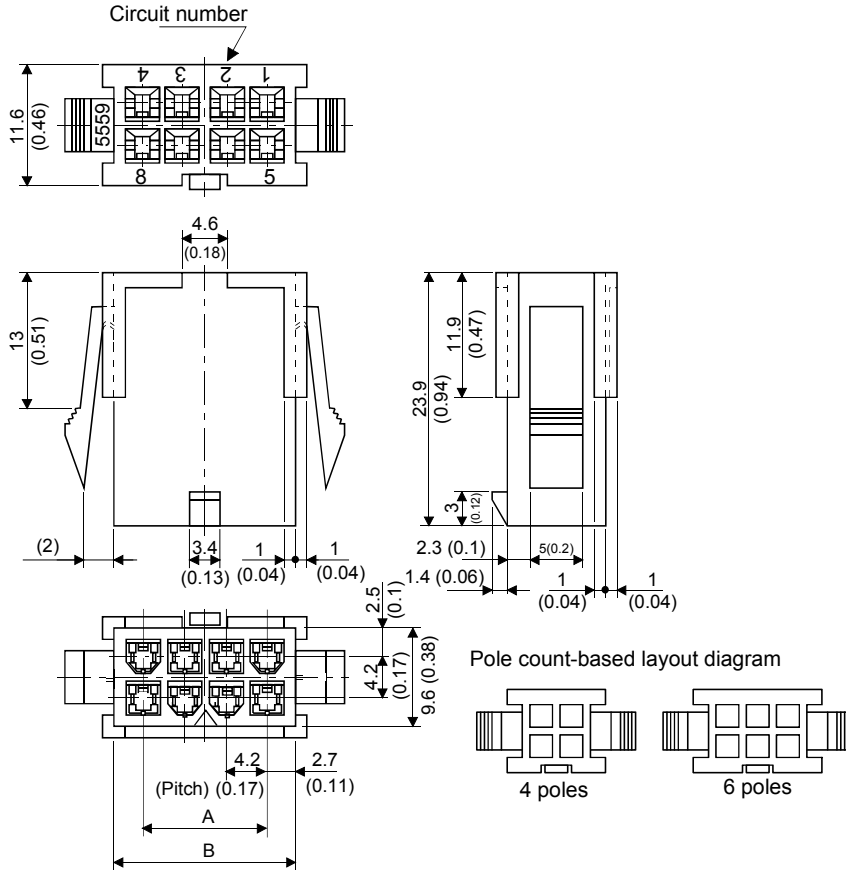

7. OUTLINE DIMENSION DRAWINGS

(4) Plug (For HC-UFC-S1) <Hirose Electric>

[Unit: mm]
([Unit: in])

RM15WTJA-4S

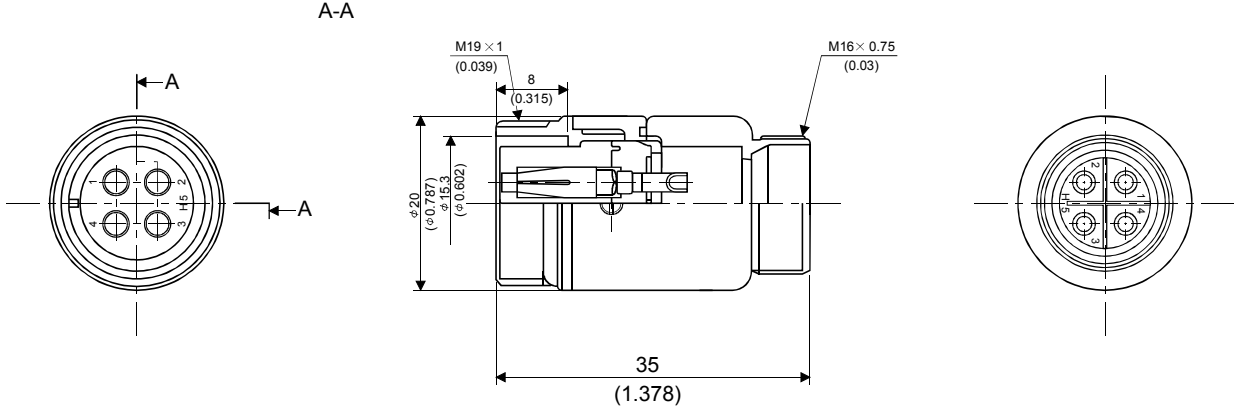

RM15WTP-CP(8)

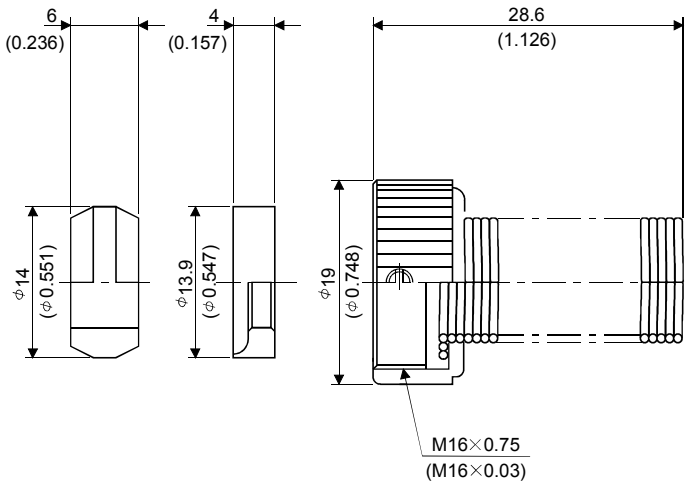

RM15WTJA-10S-(7)

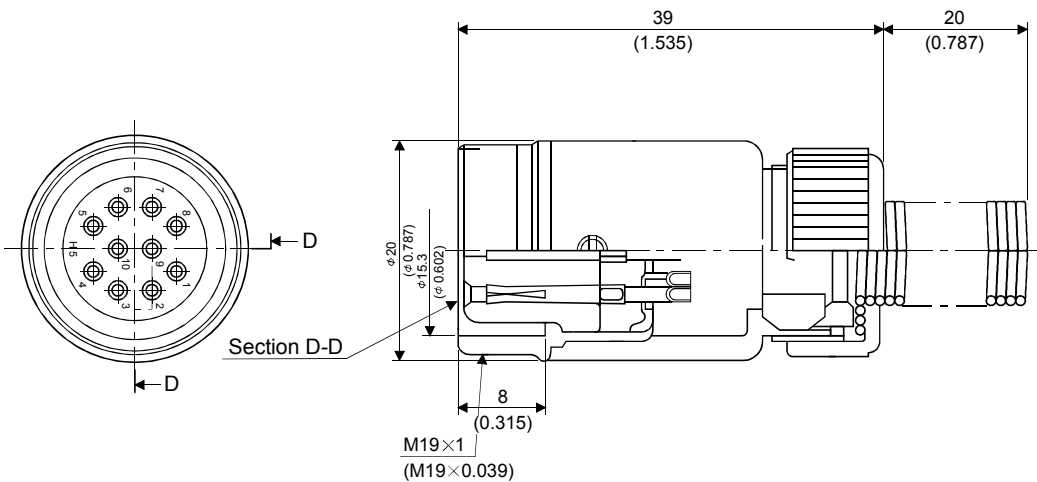

Note: The numeral within the parentheses of the connector type indicates the applicable cable diameter, and the above diagrams show examples. The numeral depends on the used cable diameter.

8. CALCULATION METHODS FOR DESIGNING

8. CALCULATION METHODS FOR DESIGNING

8.1 Specification symbol list

The following symbols are required for selecting the proper servo:

T_a	: Acceleration torque [N · m]	g	: Gravitational acceleration (9.8[m/s ²])
T_d	: Deceleration torque [N · m]	μ	: Friction coefficient
T_{Ma}	: Servo motor torque necessary for acceleration [N · m]	π	: Circle ratio (3.14)
T_{Md}	: Servo motor torque necessary for deceleration [N · m]	P_t	: Number of feedback pulses in position control mode [pulse/rev]
T_{LH}	: Torque applied during servo motor stop [N · m]	f	: Input pulse frequency in position control mode [pps]
T_L	: Load torque converted into equivalent value on servo motor shaft [N · m]	f_0	: Input pulse frequency during fast feed in position control mode [pps]
T_U	: Unbalance torque [N · m]	t_{psa}	: Acceleration time constant of pulse frequency command in position control mode [s]
T_F	: Load friction torque [N · m]	t_{psd}	: Deceleration time constant of pulse frequency command in position control mode [s]
T_{L0}	: Load torque on load shaft [N · m]	K_p	: Position control gain 1 [rad/s]
T_{rms}	: Continuous effective load torque converted into equivalent value on servo motor shaft [N · m]	T_p	: Position control time constant ($T_p=1/K_p$) [s]
J_L	: Load inertia moment converted into equivalent value on servo motor shaft [kg · cm ²]	$\Delta \ell$: Feed per feedback pulse in position control mode [mm/pulse]
J_{L0}	: Load inertia moment on load shaft [kg · cm ²]	$\Delta \ell_0$: Feed per command pulse in position control mode [mm/pulse]
J_M	: Servo motor's rotor inertia moment [kg · cm ²]	ℓ	: Feed [mm]
N	: Servo motor speed [r/min]	P	: Number of internal command pulses [pulse]
N_0	: Servo motor speed during fast feed [r/min]	t_s	: Internal settling time [s]
N_{L0}	: Load shaft speed during fast feed [r/min]	t_0	: Positioning time [s]
V	: Moving part speed [mm/min]	t_c	: Time at constant speed of servo motor in 1 cycle [s]
V_0	: Moving part speed during fast feed [mm/min]	t_ℓ	: Stopping time in 1 cycle [s]
P_b	: Ball screw lead [mm]	$\Delta \varepsilon$: Positioning accuracy [mm]
Z_1	: Number of gear teeth on servo motor shaft	ε	: Number of droop pulses [pulse]
Z_2	: Number of gear teeth on load gear	ΔS	: Feed per servo motor revolution [mm/rev]
n	: Gear ratio $n = \frac{Z_2}{Z_1}$ Speed reduced when $n > 1$, Speed increased when $n < 1$	W	: Mass [kg]
η	: Drive system efficiency		

8. CALCULATION METHODS FOR DESIGNING

8.2 Position resolution and electronic gear setting

Position resolution (travel per pulse $\Delta \ell$) is determined by travel per servo motor revolution ΔS and the number of encoder feedback pulses P_t , and is represented by Equation 8.1. As the number of feedback pulses depends on the servo motor series, refer to Section 5.1.

$$\Delta \ell = \frac{\Delta S}{P_t} \dots\dots\dots (8.1)$$

$\Delta \ell$: Travel per pulse [mm]
 ΔS : Travel per servo motor revolution [mm/rev]
 P_t : Number of feedback pulses [pulse/rev]

Since $\Delta \ell$ has the relationship represented by Equation 8.1, its value is fixed in the control system after the drive system and encoder have been determined. However, travel per command pulse can be set as desired using the parameters.

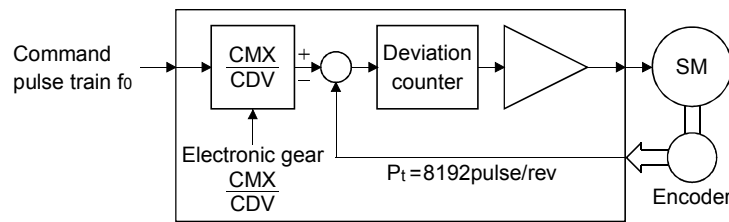

As shown above, command pulses are multiplied by CMX/CDV set in the parameters to be position control pulses. Travel per command pulse $\Delta \ell_0$ is expressed by Equation 8.2:

$$\Delta \ell_0 = \frac{P_t}{\Delta S} \cdot \frac{CMX}{CDV} = \Delta \ell \cdot \frac{CMX}{CDV} \dots\dots\dots (8.2)$$

CMX: Electronic gear (Command pulse multiplication numerator)
 CDV: Electronic gear (Command pulse multiplication denominator)

Using the above relationship, travel per command pulse can be set to a value without fraction.

[Setting example]

Find a parameter value for $\Delta \ell_0 = 0.01$ [mm] in a drive system where ball screw lead $PB = 10$ [mm] and reduction ratio $1/n = 1$.

The encoder feedback pulses P_t of the HC–MF = 8192 [pulses/rev].

Since $\Delta s = 10$ [mm/rev], the following is obtained according to Equation 8.2:

$$\frac{CMX}{CDV} = \Delta \ell_0 \cdot \frac{P_t}{\Delta S} = 0.01 \cdot \frac{8192}{10} = \frac{1024}{125}$$

<Relationship between position resolution $\Delta \ell$ and overall accuracy>

Positioning accuracy of machine is the sum of electrical errors and mechanical errors. Normally, provisions should be made so that positioning accuracy are not affected by electrical system errors. As a guideline, Equation 8.3 should be satisfied:

$$\Delta \ell < \left[\frac{1}{5} \text{ to } \frac{1}{10} \right] \cdot D \varepsilon \dots\dots\dots (8.3)$$

where, $\Delta \ell$: Travel per feedback pulse [mm/pulse]
 $\Delta \varepsilon$: Positioning accuracy [mm]

8. CALCULATION METHODS FOR DESIGNING

8.3 Speed and command pulse frequency

The servo motor is run at a speed where the command pulses and feedback pulses are equivalent. Therefore, the command pulse frequency and feedback pulse frequency are equivalent. The relation including the parameter settings (CMX, CDV) is as indicated below (refer to the following diagram):

$$f_0 \cdot \frac{CMX}{CDV} = P_t \cdot \frac{N_0}{60} \dots\dots\dots (8.4)$$

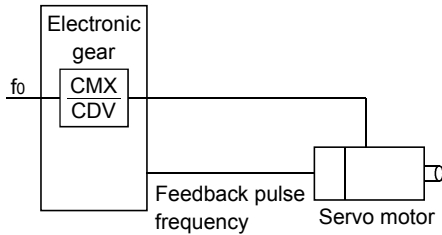

- f₀ :Command pulse frequency [pps]
- CMX :Electronic gear
(Commanded pulse multiplication numerator)
- CDV :Electronic gear
(Commanded pulse multiplication denominator)
- N₀ :Servo motor speed [r/min]
- P_t :Number of feedback pulses [pulses/rev]
(P_t = 8192 for HC-MF)

According to Equation 8.4, the following equations may be used to obtain the electronic gear and command pulse frequency to rotate the servo motor at N₀.

• Electronic gear

$$\frac{CMX}{CDV} = P_t \cdot \frac{N_0}{60} \cdot \frac{1}{f_0} \dots\dots\dots (8.5)$$

• Command pulse frequency

$$f_0 = P_t \cdot \frac{N_0}{60} \cdot \frac{CDV}{CMX} \dots\dots\dots (8.6)$$

[Setting example]

Obtain the command pulse frequency required to run the HC-MF at 3000r/min.

When the electronic gear ratio 1 (initial parameter value) is used, the following result is found according to Equation 8.6:

$$f_0 = 8192 \cdot \frac{N_0}{60} \cdot \frac{CDV}{CMX}$$

(Command pulse frequency)

$$= 8192 \cdot \frac{3000}{60} \cdot 1$$

$$= 409600[\text{pps}]$$

However, as the maximum input command pulse frequency in the open collector system is 200kpps, for general-purpose servo 409600pps cannot be entered.

To run the servo motor at the speed of 3000r/min at not more than 200kpps, the electronic gear setting must be changed. This electronic gear is found by Equation 8.5:

$$\frac{CMX}{CDV} = 8192 \cdot \frac{3000}{60} \cdot \frac{1}{200 \cdot 10^3}$$

(Electronic gear)

$$= \frac{256}{125}$$

Therefore, the parameters are set to CMX=256 and CDV = 125.

8. CALCULATION METHODS FOR DESIGNING

8.4 Stopping characteristics

(1) Droop pulses (ε)

When a pulse train command is used to run the servo motor, there is a relationship between the command pulse frequency and servo motor speed as shown in the figure. The difference between the command pulses and feedback pulses during acceleration are called droop pulses, which are accumulated in the servo amplifier's deviation counter. Equation 8.7 defines a relationship between the command pulse frequency (f) and position control gain $1(K_p)$.

$$\varepsilon \cong \frac{f_0}{K_p} [\text{pulse}] \dots\dots\dots (8.7)$$

Supposing that the value of position control gain 1 is 70 [rad/s], the droop pulses during operation will be as follows at the command pulse frequency of 200 [kpps] according to Equation 15.1:

$$\varepsilon \cong \frac{200 \cdot 10^3}{1} \cong 2858 [\text{pulse}]$$

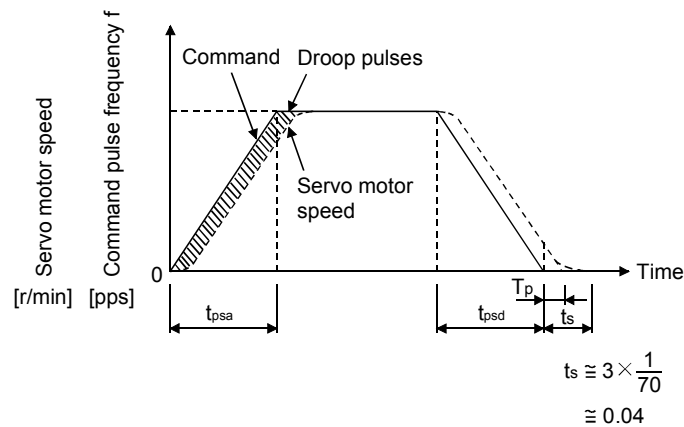

(2) Settling time (t_s) during linear acceleration/deceleration

Since droop pulses still exist when there are no command pulses, settling time (t_s) is required until the servo motor stops. Set the operation pattern in consideration for the settling time.

The settling time (t_s) value is obtained according to Equation 8.8:

$$t_s \cong 3 \cdot T_p$$

$$= 3 \cdot \frac{1}{K_p} [\text{s}] \dots\dots\dots (8.8)$$

*When $K_p = 70$ [rad/s], $t_s \cong 0.04$ [s]. (Refer to the above diagram.)

The settling time (t_s) indicates the time required for the servo motor to stop in the necessary positioning accuracy range. This does not always mean that the servo motor has stopped completely. Thus, especially when the servo motor is used in high-duty operation and positioning accuracy has no margin for travel per pulse ($\Delta \ell$), the value obtained by Equation 8.8 must be increased.

The settling time (t_s) will vary with the moving part conditions. Especially when the load friction torque is large, movement may be unstable near the stopping position.

8. CALCULATION METHODS FOR DESIGNING

8.5 Capacity selection

As a first step, confirm the load conditions and temporarily select the servo motor capacity. Then, determine the operation pattern, calculate required torques according to the following equations, and check that the servo motor of the initially selected capacity may be used for operation .

(1) Initial selection of servo motor capacity

After calculating the load torque (T_L) and load inertia moment (J_L), select a servo motor which will satisfy the following two relationships:

Servo motor's rated torque > T_L

Servo motor $J_M > J_L/m$

$$m = 3$$

: High duty (more than 100 times/min.)

Settling time 40ms or less

$$m = 5$$

: Middle duty (60 to 100 times/min.)

Settling time 100ms or less

$$m = \text{permissible load inertia moment}$$

: Low duty (less than 60 times/min.)

Settling time more than 100ms

Find the acceleration and deceleration torques and continuous effective load torque as described in (2) to make a final selection. For high-duty positioning, the load inertia moment (J_L) value should be as small as possible. If positioning is infrequent as in line control, the load inertia moment (J_L) value may be slightly larger than in the above conditions.

(2) Acceleration and deceleration torques

The following equations are used to calculate the acceleration and deceleration torques in the following operation pattern:

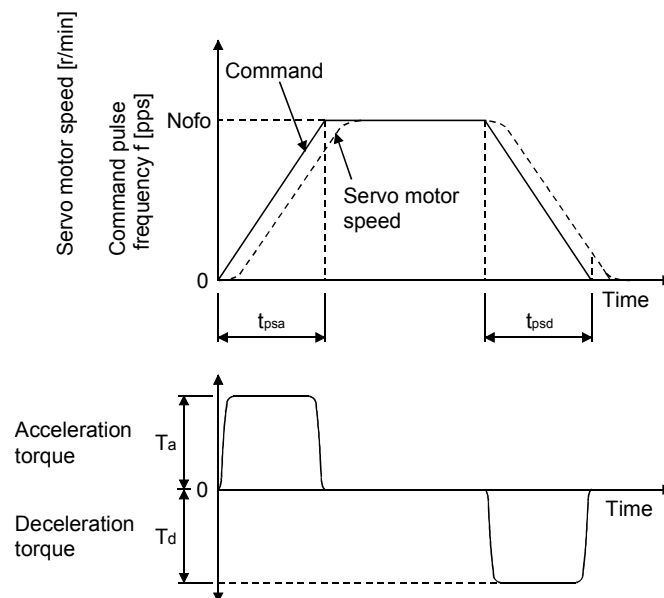

$$\bullet \text{ Acceleration torque } T_a = \frac{(J_L + J_M) \cdot N_o}{9.55 \cdot 10^4} \cdot \frac{1}{t_{psa}} \dots \dots \dots (8.9)$$

$$\bullet \text{ Deceleration torque } T_d = \frac{(J_L + J_M) \cdot N_o}{9.55 \cdot 10^4} \cdot \frac{1}{t_{psd}} \dots \dots \dots (8.10)$$

8. CALCULATION METHODS FOR DESIGNING

(3) Torques required for operation

Torques required for the servo motor are the highest during acceleration. If any of the torques obtained with Equations 8.11 to 8.13 exceeds the maximum servo motor torque, the servo motor speed cannot be increased as commanded. Confirm that the calculated value is lower than the servo motor's maximum torque. Since a friction load is normally applied during deceleration, only the acceleration torque needs to be considered. In the regenerative mode, the value found by Equation 8.13 is negative.

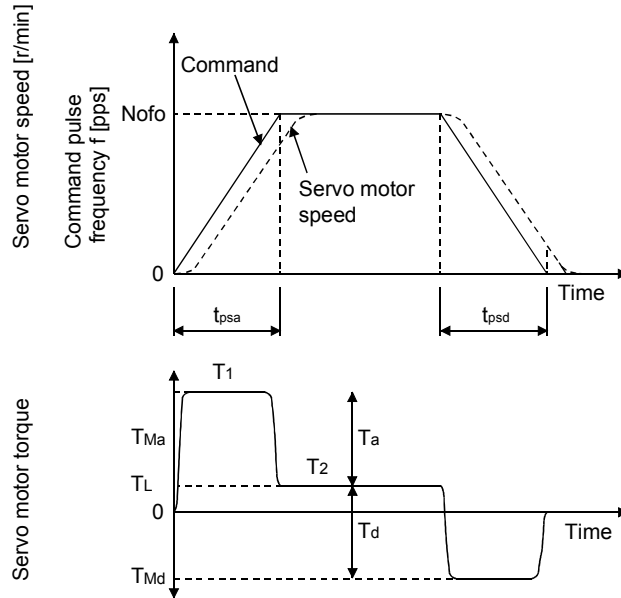

$$T_1 = T_{Ma} = T_a + T_L \dots\dots\dots (8.11)$$

$$T_2 = T_L \dots\dots\dots (8.12)$$

$$T_3 = T_{Md} = -T_d + T_L \dots\dots\dots (8.13)$$

8. CALCULATION METHODS FOR DESIGNING

(4) Continuous effective load torque

If the torque required for the servo motor changes with time, the continuous effective load torque should be lower than the rated torque of the servo motor. There may be a servo motor torque delay at the start of acceleration or deceleration due to a delay in the control system. To simplify the calculation, however, it is assumed that constant acceleration and deceleration torques are applied during t_{psa} and t_{psd} . The following equation is used to calculate the continuous effective load torque in the following operation pattern. TLH indicates the torque applied during a servo motor stop. A large torque may be applied especially during a stop in vertical motion applications, and this must be fully taken into consideration. During vertical drive, the unbalanced torque TU will become TLH.

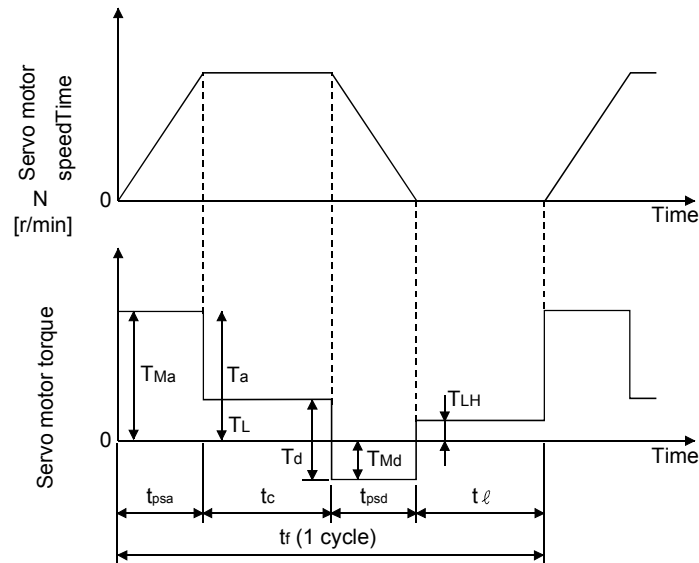

$$T_{rms} = \sqrt{\frac{T_{Ma}^2 \cdot t_{psa} + T_L^2 \cdot t_c + T_{Md}^2 \cdot t_{psd} + T_{LH}^2 \cdot t_l}{t_f}} \dots\dots\dots (8.14)$$

8. CALCULATION METHODS FOR DESIGNING

8.6 Load torque equations

Typical load torque equations are indicated below:

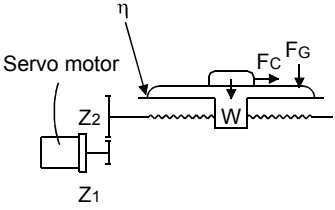
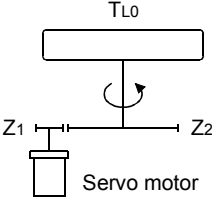
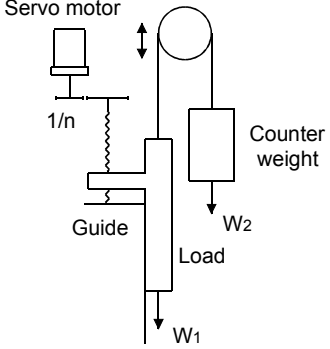
Type	Mechanism	Equation
Linear movement		$T_L = \frac{F}{2 \cdot 10^3 \cdot \pi \cdot \eta} \cdot \frac{V}{N} = \frac{F \cdot \Delta S}{2 \cdot 10^3 \cdot \pi \cdot \eta} \dots \dots \dots (8.15)$ <p>F : Force in the axial direction of the machine in linear motion [N] F in Equation 15.9 is obtained with Equation 8.16 when the table is moved, for example, as shown in the left diagram.</p> $F = F_c + \mu \cdot (W \cdot g + F_G) \dots \dots \dots (8.16)$ <p>F_c : Force applied in the axial direction of the moving part [N] F_G : Tightening force of the table guide surface [N] W : Full mass of the moving part [kg]</p>
Rotary movement		$T_L + \frac{1}{n} \cdot \frac{1}{\eta} \cdot T_{L0} + T_F \dots \dots \dots (8.17)$ <p>T_F : Load friction torque converted into equivalent value on servo motor shaft [N · m]</p>
Vertical movement		<p>During rise</p> $T_L = T_U + T_F \dots \dots \dots (8.18)$ <p>During fall</p> $T_L = -T_U \cdot \eta^2 + T_F \dots \dots \dots (8.19)$ <p>T_F: Friction torque of the moving part [N · m]</p> $T_U = \frac{(W_1 - W_2) \cdot g}{2 \cdot 10^3 \cdot \pi \cdot \eta} \cdot \frac{V}{N} = \frac{(W_1 - W_2) \cdot g \cdot \Delta S}{2 \cdot 10^3 \cdot \pi \cdot \eta} \dots \dots \dots (8.20)$ $T_F = \frac{\mu (W_1 + W_2) \cdot g \cdot \Delta S}{2 \cdot 10^3 \cdot \pi \cdot \eta} \dots \dots \dots (8.21)$ <p>W_1: Mass of load [kg] W_2: Mass of counterweight [kg]</p>

8.7 Expression for calculating the electromagnetic brake workload

Calculate the brake workload E_b [J] at an emergency stop with the following expression.

$$E_b = \frac{(J_M + J_L) \cdot N^2}{182} \cdot 10^{-4}$$

N : Servo motor speed [r/min]

J_M : Servo motor's rotor inertia moment [kg · cm²]

J_L : Load inertia moment converted into equivalent value on servo motor shaft [kg · cm²]

8. CALCULATION METHODS FOR DESIGNING

8.8 Load inertia moment equations

Typical load inertia moment equations are indicated below:

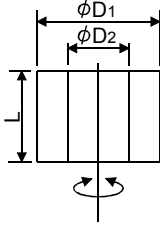
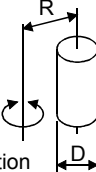
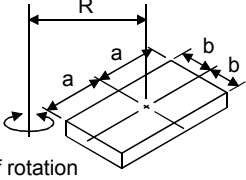
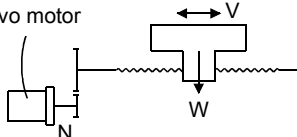
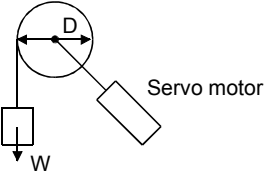
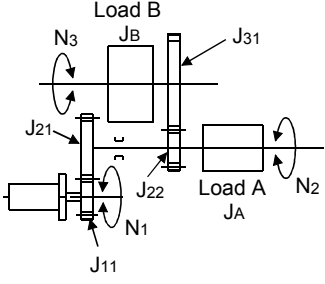
Type	Mechanism	Equation
Cylinder	<p>Axis of rotation is on the cylinder center</p>  <p>Axis of rotation</p>	$J_{L0} = \frac{\pi \cdot \rho \cdot L}{32} \cdot (D_1^4 - D_2^4) = \frac{W}{8} \cdot (D_1^2 + D_2^2) \dots\dots\dots(8.22)$ <p> ρ : Cylinder material density [kg/cm³] L : Cylinder length [cm] D₁ : Cylinder outside diameter [cm] D₂ : Cylinder inside diameter [cm] W : Cylinder mass [kg] </p> <p>Reference data: material density Iron : 7.8 · 10⁻³ [kg/cm³] Aluminum : 2.7 · 10⁻³ [kg/cm³] Copper : 8.96 · 10⁻³ [kg/cm³]</p>
	<p>Axis of rotation is off the cylinder center</p>  <p>Axis of rotation</p>	$J_{L0} = \frac{W}{8} \cdot (D^2 + 8R^2) \dots\dots\dots(8.23)$
Square block	 <p>Axis of rotation</p>	$J_{L0} = W \cdot \left(\frac{a^2 + b^2}{3} + R^2 \right) \dots\dots\dots(8.24)$ <p> W : Square block mass [kg] a, b, R : Left diagram [cm] </p>
Object which moves linearly	<p>Servo motor</p> 	$J_L = W \cdot \frac{V}{600 \cdot \omega} = W \cdot \left(\frac{1}{2 \cdot \pi \cdot N} \cdot \frac{V}{10} \right)^2 = W \cdot \left(\frac{\Delta S}{20 \cdot \pi} \right)^2 \dots\dots\dots(8.25)$ <p> V : Speed of object moving linearly [mm/min] ΔS : Moving distance of object moving linearly per servo motor revolution [mm/rev] W : Object mass [kg] </p>
Object that is hung with pulley	 <p>Servo motor</p>	$J_L = W \cdot \left(\frac{D}{2} \right)^2 + J_p \dots\dots\dots(8.26)$ <p> J_p : Pulley inertia moment [kg · cm²] D : Pulley diameter [cm] W : Object mass [kg] </p>
Converted load		$J_L = J_{11} + (J_{21} + J_{22} + J_A) \cdot \left(\frac{N_2}{N_1} \right)^2 + (J_{31} + J_B) \cdot \left(\frac{N_3}{N_1} \right)^2 \dots\dots\dots(8.27)$ <p> J_A, J_B : Inertia moments of loads A, B [kg · cm²] J₁₁ to J₃₁ : Inertia moments [kg · cm²] N₁ to N₃ : Speed of each shaft [r/min] </p>

8. CALCULATION METHODS FOR DESIGNING

8.9 Precautions for zeroing

When a general positioning unit is used, the sequence of events is as shown in the following figure.

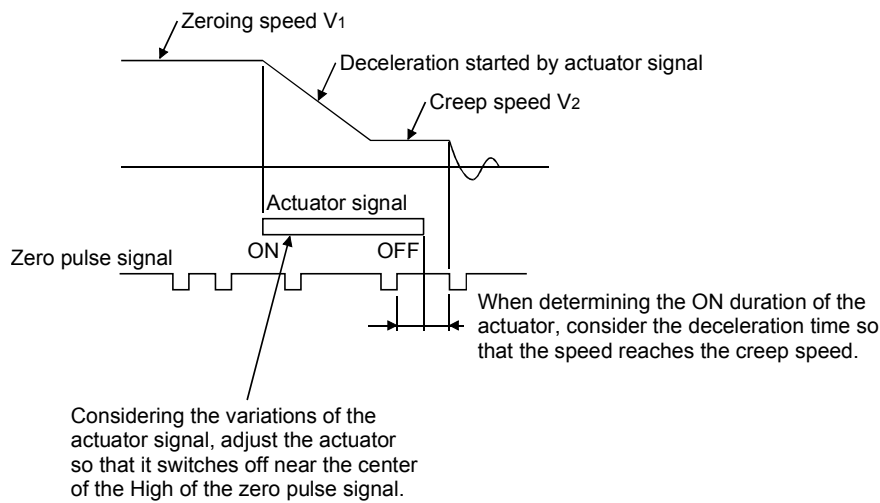

- (1) When determining the ON duration of the actuator, consider the delay time of the control section and the deceleration time so that the creep speed is attained. If the actuator signal switches off during deceleration, precise home position return cannot be performed.

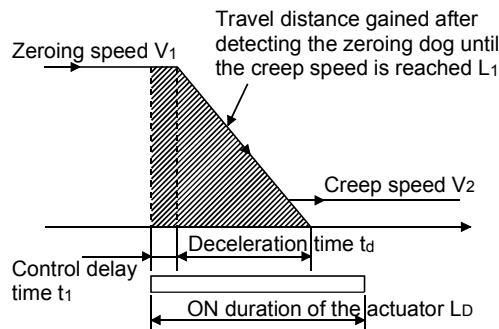

Travel distance L_1 in the chart can be obtained by Equation 8.28

$$L_1 = \frac{1}{60} \cdot V_1 \cdot t_1 + \frac{1}{120} \cdot V_1 \cdot t_d \cdot \left\{ 1 - \left(\frac{V_2}{V_1} \right)^2 \right\} + \frac{1}{60} \cdot V_1 \cdot T_p \dots \dots \dots (8.28)$$

ON duration of the actuator L_D [mm] must be longer than L_1 obtained by Equation 8.28, as indicated in Equation 8.29

$$L_D > L_1 \dots \dots \dots (8.29)$$

where,

V_1, V_2 : As shown in the chart [mm/min]

t_1, t_d : As shown in the chart [s]

L_1 : As shown in the chart [mm]

L_D : As shown in the chart [mm]

8. CALCULATION METHODS FOR DESIGNING

(2) Set the end (OFF position) of the actuator signal at the middle of two ON positions (Lows) of the zero pulse signal. If it is set near either ON position of the zero pulse signal, the positioning unit is liable to misdetect the zero pulse signal. In this case, a fault will occur, e.g. the home position will shift by one revolution of the servo motor.

The zero pulse output position can be confirmed by OP (encoder Z-phase pulse) on the external I/O signal display.

8.10 Selection example

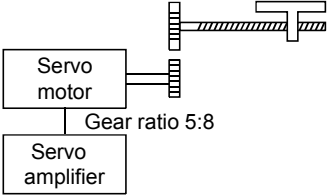
Machine specifications	Speed of moving part during fast feed	V_0	= 30000[mm/min]
	Command resolution	$\Delta \ell$	= 10[μ m]
	Travel	ℓ	= 400[mm]
	Positioning time	t_0	= within 1[s]
	Number of feeds		40[times/min]
	Operation cycle	t_f	= 1.5[s]
	Gear ratio	n	= 8/5
	Moving part mass	W	= 60[kg]
	Drive system efficiency	η	= 0.8
	Friction coefficient	μ	= 0.2
	Ball screw lead	P_b	= 16[mm]
Ball screw diameter		20[mm]	
Ball screw length		500[mm]	
Gear diameter (servo motor)		25[mm]	
Gear diameter (load shaft)		40[mm]	
Gear face width		10[mm]	

(1) Selection of control parameters

Setting of electronic gear (command pulse multiplication numerator, denominator)

There is the following relationship between the multiplication setting and travel per pulse $\Delta \ell$.

$$\Delta \ell = \frac{(\text{ball screw lead})}{8192 \cdot (\text{gear ration})} \cdot \left(\frac{\text{CMX}}{\text{CDV}} \right)$$

When the above machining specifications are substituted in the above equation:

$$\frac{\text{CMX}}{\text{CDV}} = 10 \cdot \frac{8192 \cdot 8/5}{16 \cdot 1000} = \frac{8192}{1000}$$

Acceptable as CMX/CDV is within 1/20 to 20.

(2) Servo motor speed

$$N_0 = \frac{V_0}{P_b} \cdot n = \frac{30000}{16} \cdot \frac{8}{5} = 3000[\text{r/min}]$$

8. CALCULATION METHODS FOR DESIGNING

(3) Acceleration/deceleration time constant

$$t_{psa} = t_{psd} = t_0 - \frac{\ell}{V_0/60} - t_s = 0.05[\text{s}]$$

t_s : settling time.(Here, this is assumed to be 0.15s.)

(4) Operation pattern

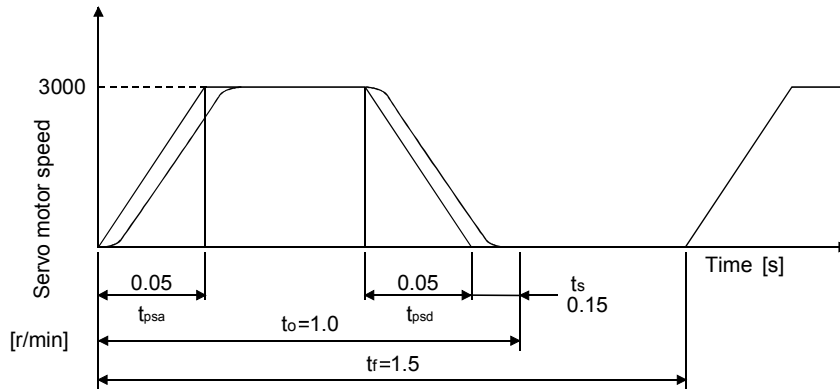

(5) Load torque (converted into equivalent value on servo motor shaft)

Travel per servo motor revolution

$$\Delta S = P_b \cdot \frac{1}{n} = 16 \cdot \frac{5}{8} = 10[\text{mm}]$$

$$T_L = \frac{\mu \cdot W \cdot g \cdot \Delta S}{2 \cdot 10^3 \cdot \pi \cdot \eta} = \frac{0.2 \cdot 60 \cdot 9.8 \cdot 10}{2 \cdot 10^3 \cdot 3.14 \cdot 0.8} = 0.23[\text{N} \cdot \text{m}]$$

8. CALCULATION METHODS FOR DESIGNING

(6) Load inertia moment (converted into equivalent value on servo motor shaft)

Moving part

$$J_{L1} = W \cdot \left(\frac{\Delta S}{20\pi} \right)^2 = 1.52[\text{kg} \cdot \text{cm}^2]$$

Ball screw

$$J_{L2} = \frac{\pi \cdot \rho \cdot L}{32} \cdot D^4 \cdot \left(\frac{1}{n} \right)^2 = 0.24[\text{kg} \cdot \text{cm}^2]$$

$$*\rho = 7.8 \cdot 10^{-3}[\text{kg} \cdot \text{cm}^3]$$

Gear (servo motor shaft)

$$J_{L3} = \frac{\pi \cdot \rho \cdot L}{32} \cdot D^4 = 0.03[\text{kg} \cdot \text{cm}^2]$$

Gear (load shaft)

$$J_{L4} = \frac{\pi \cdot \rho \cdot L}{32} \cdot D^4 \cdot \left(\frac{1}{n} \right)^2 = 0.8[\text{kg} \cdot \text{cm}^2]$$

Full load inertia moment (converted into equivalent value on servo motor shaft)

$$J_L = J_{L1} + J_{L2} + J_{L3} + J_{L4} = 2.59[\text{kg} \cdot \text{cm}^2]$$

(7) Temporary selection of servo motor

Selection conditions

(a) Load torque < servo motor's rated torque

(b) Full load inertia moment < 30 · servo motor inertia moment

From the above, the HC-MF23 (200W) is temporarily selected.

(8) Acceleration and deceleration torques

Torque required for servo motor during acceleration

$$T_{Ma} = \frac{(J_L + J_M) \cdot N_o}{9.55 \cdot 10^4 \cdot T_{psa}} + T_L = 1.7[\text{N} \cdot \text{m}]$$

Torque required for servo motor during deceleration

$$T_{Md} = \frac{(J_L + J_M) \cdot N_o}{9.55 \cdot 10^4 \cdot T_{psd}} + T_L = -1.2[\text{N} \cdot \text{m}]$$

The torque required for the servo motor during deceleration must be lower than the servo motor's maximum torque.

8. CALCULATION METHODS FOR DESIGNING

(9) Continuous effective load torque

$$T_{rms} = \sqrt{\frac{T_{Ma}^2 \cdot t_{psa} + T_L^2 \cdot t_c + T_{Md}^2 \cdot t_{psd}}{t_f}} = 0.42[\text{N} \cdot \text{m}]$$

The continuous effective load torque must be lower than the servo motor's rated torque.

(10) Torque pattern

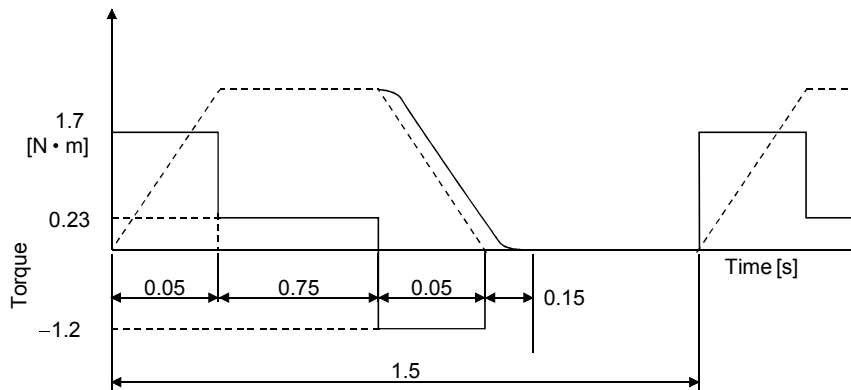

(11) Selection results

The HC-MF23 servo motor and MR-J2-20A servo amplifier are selected.

(a) Electronic gear setting

$$CMX = 8192$$

$$CDV = 1000$$

(b) During rapid feed

$$\text{Servo motor speed } N_0 = 3000 [\text{r/min}]$$

(c) Acceleration/deceleration time constant

$$t_{psa} = t_{psd} = 0.05[\text{s}]$$

APPENDIX

App. 1 Servo motor ID codes

Motor series ID	Motor type ID	Encoder ID	Servo motor
02	F053	003D	HC-MF053
	FF13		HC-MF13
	FF23		HC-MF23
	FF43		HC-MF43
	FF73		HC-MF73
11	F053		HA-FF053
	FF13		HA-FF13
	FF23		HA-FF23
	FF33		HA-FF33
	FF43		HA-FF43
	FF63		HA-FF63
12	F053		HC-KF053
	FF13		HC-KF13
	FF23		HC-KF23
	FF43		HC-KF43
	FF73	HC-KF73	
21	FF81	003C	HC-SF81
	F121		HC-SF121
	F201		HC-SF201
	F301		HC-SF301
	FF52		HC-SF52
	F102		HC-SF102
	F152		HC-SF152
	F202		HC-SF202
	F352		HC-SF352
	F502		HC-SF502
	F702		HC-SF702
	FF53		HC-SF53
	F103		HC-SF103
F153	HC-SF153		
22	F203	HC-SF203	
	F353	HC-SF353	
31	FF13	HC-UF13	
	FF23	HC-UF23	
	FF43	HC-UF43	
	FF73	HC-UF73	
	FF32	HC-UF32	
	FF72	HC-UF72	
	F152	HC-UF152	
F202	HC-UF202		
41	F103	003C	HC-RF103
	F153		HC-RF153
	F203		HC-RF203
02	F053	0041	HC-MFS053
	FF13		HC-MFS13
	FF23		HC-MFS23
	FF43		HC-MFS43
	FF73		HC-MFS73
12	F053	HC-KFS053	
	FF13	HC-KFS13	
	FF23	HC-KFS23	
	FF43	HC-KFS43	
	FF73	HC-KFS73	

APPENDIX

Motor series ID	Motor type ID	Encoder ID	Servo motor
21	FF81	0041	HC-SFS81
	F121		HC-SFS121
	F201		HC-SFS201
	F301		HC-SFS301
	FF52		HC-SFS52
	F102		HC-SFS102
	F152		HC-SFS152
	F202		HC-SFS202
	F352		HC-SFS352
	F502		HC-SFS502
	F702		HC-SFS702
	FF53		HC-SFS53
	F103		HC-SFS103
	F153		HC-SFS153
22	F203	HC-SFS203	
	F353	HC-SFS353	
24	FF52	HC-SFS524	
	F102	HC-SFS1024	
	F152	HC-SFS1524	
	F202	HC-SFS2024	
	F352	HC-SFS3524	
	F502	HC-SFS5024	
	F702	HC-SFS7024	
31	FF13	HC-UFS13	
	FF23	HC-UFS23	
	FF43	HC-UFS43	
	FF72	HC-UFS72	
	FF73	HC-UFS73	
	F152	HC-UFS152	
	F202	HC-UFS202	
	F352	HC-UFS352	
41	F502	HC-UFS502	
	F103	HC-RFS103	
	F153	HC-RFS153	
	F203	HC-RFS203	
	F353	HC-RFS353	
51	F503	HC-RFS503	
	FF52	HC-LFS52	
	F102	HC-LFS102	
	F152	HC-LFS152	
	F202	HC-LFS202	
53	F302	HC-LFS302	
	F601	HA-LFS601	
	F801	HA-LFS801	
	1201	HA-LFS12K1	
	1501	HA-LFS15K1	
	2001	HA-LFS20K1	
	2501	HA-LFS25K1	
	3001	HA-LFS30K1	
	3701	HA-LFS37K1	
	F502	HA-LFS502	
	F702	HA-LFS702	
	1102	HA-LFS11K2	
	1502	HA-LFS15K2	
	2202	HA-LFS22K2	
3002	HA-LFS30K2		
3702	HA-LFS37K2		

APPENDIX

Motor series ID	Motor type ID	Encoder ID	Servo motor
54	F601	0041	HA-LFS6014
	F801		HA-LFS8014
	1201		HA-LFS12K14
	1501		HA-LFS15K14
	2001		HA-LFS20K14
	1102		HA-LFS11K24
	1502		HA-LFS15K24
	2202		HA-LFS22K24
	2501		HA-LFS25K14
	3001		HA-LFS30K14
	3701		HA-LFS37K14
	3002		HA-LFS30K24
	3702		HA-LFS37K24
	4502		HA-LFS45K24
5502	HA-LFS55K24		
55	F701	HA-LFS701M	
	1101	HA-LFS11K1M	
	1501	HA-LFS15K1M	
	2201	HA-LFS22K1M	
	3001	HA-LFS30K1M	
	3701	HA-LFS37K1M	
56	F701	HA-LFS701M4	
	1101	HA-LFS11K1M4	
	1501	HA-LFS15K1M4	
	2201	HA-LFS22K1M4	
	3001	HA-LFS30K1M4	
	3701	HA-LFS37K1M4	
	4501	HA-LFS45K1M4	
57	5001	HA-LFS50K1M4	

App. 2 Change of connector sets to the RoHS compatible products

The following connector sets have been changed to RoHS compliant since September 2006.

RoHS compliant and non-RoHS compliant connector sets may be mixed based on availability.

Only the components of the connector set that have changed are listed below.

Model	Current Product	RoHS Compatible Product
MR-ENCNS	Amplifier connector (3M or equivalent) 10120-3000VE (connector) MS3106A20-29S (D190) (Plug, DDK) CE3057-12A-3 (D265) (Cable clump, DDK) CE02-20BS-S (Back shell, DDK)	Amplifier connector (3M or equivalent) 10120-3000PE (connector) D/MS3106A20-29S (D190) (Plug, DDK) CE3057-12A-3-D (Cable clump, DDK) CE02-20BS-S-D (Back shell, DDK)
MR-PWCNS1	Power supply connector (DDK) CE05-6A22-23SD-B-BSS (Connector and back shell) CE3057-12A-2 (D265) (Cable clump)	Power supply connector (DDK) CE05-6A22-23SD-D-BSS (Connector and back shell) CE3057-12A-2-D (Cable clump)
MR-PWCNS2	Power supply connector (DDK) CE05-6A24-24SD-B-BSS (Connector and back shell) CE3057-16A-2 (D265) (Cable clump)	Power supply connector (DDK) CE05-6A24-10SD-B-BSS (Connector and back shell) CE3057-16A-2-D (Cable clump)
MR-PWCNS3	Power supply connector (DDK) CE05-6A32-17SD-B-BSS (Connector and back shell) CE3057-20A-1 (D265) (Cable clump)	Power supply connector (DDK) CE05-6A32-17SD-D-BSS (Connector and back shell) CE3057-20A-1-D (Cable clump)
MR-BKCN	Electromagnetic brake connector MS3106A10SL-4S (D190) (Plug, DDK)	Electromagnetic brake connector D/MS3106A10SL-4S (D190) (Plug, DDK)

REVISIONS

*The manual number is given on the bottom left of the back cover.

Print Data	*Manual Number	Revision
May., 1998	SH(NA)3181-A	First edition
Sep., 1998	SH(NA)3181-B	<p>HA-LH11K2 to 22K2 added HC-SF502(B), 702(B) added HC-RF353(B), 503(B) added HC-UF352(B), 502(B)/HC-UF73(B) added UL/C-UL Standard: Flange size list modified Section 1.3: Terminal box type added Chapter 3: Overall changes Section 5.1: Applicable servo amplifier and regenerative brake duty added for MR-H□-N Power supply capacity deleted Section 5.3: HC-MF's permissible speed changed Section 7.1.1 (2), (c), 2): HA-FF053BG1 1/5 inertia moment changed Section 7.3: Reviewed due to overall changes to Chapter 3</p>
Feb., 1999	SH(NA)3181-C	<p>HC-KF23(B), 43(B) added HC-AQ0135(B) to 0335(B) added HA-LF30K24 to 55K24 added HC-UF-S1 added UL/C-UL Standard: Flange size list modified Section 1.1: Servo motor feature list modified Section 1.2, (2), (h): HC-KF, HC-AQ, HA-LF added to the models Section 2.1: HC-KF, HC-AQ, HA-LF added to the list Section 2.3: Sentence modified Section 2.5: HC-KF, HC-AQ, HA-LF added to the list Section 2.6: HC-KF, HC-AQ, HA-LF added Section 2.7: Addition Section 3.1.4: HC-AQ added Section 3.2: List modified Section 3.3: HC-AQ added Section 5.1: HC-KF, HC-AQ, HA-LF added Insulation class added Regenerative brake duty changed: HC-SF121, HC-SF301, HC-RF503, HC-UF72, HC-UF152, HC-UF23, HC-UF43, HC-UF73 Rated current, maximum current changed: HC-SF702 Section 5.2: HC-KF, HC-AQ, HA-LF added HC-UF73 modified Section 5.3: HC-KF added Section 6.1: HC-KF, HC-AQ added Section 7.1.1: HC-UF73 modified HC-UF73B, HC-UF-S1, HC-KF, HC-AQ, HA-LF added Section 7.1.2: HC-KF-UE added Section 7.2.1: HC-UF73 modified HC-UF73B, HC-UF-S1, HC-KF, HC-AQ, HA-LF added Section 7.2.2: HC-KF-UE added</p>
Mar., 2000	SH(NA)3181-D	<p>HC-KFS, HC-MFS, HC-SFS, HC-RFS, HC-UFS, HC-LF30K2 addition Section 1.1: Motor addition Section 1.2: Motor addition Section 2.1: Table modification Section 2.2: Motor addition Section 2.5: Motor addition Section 2.6: Sentence change, motor addition to table Sections 3.1.1 to 3.1.3: Reconsideration</p>

Print Data	*Manual Number	Revision
Mar., 2000	SH(NA)3181-D	<p>Section 3.1.5: Reconsideration</p> <p>Sections 3.2, 3.3: Motor addition</p> <p>Section 5.1: Note 12 change, motor addition</p> <p>Sections 5.2 to 5.4: Motor addition</p> <p>Section 7.1: Item reconsideration, motor addition HC-MF, HC-KF, HC-UF3000r/min outline drawing change</p> <p>Section 7.2 (3): Plug addition</p>
Feb., 2001	SH(NA)3181-E	<p>Addition of HC-KFS73, HC-SFS502 · 702, HC-RFS352 · 502 and HC-UFS502</p> <p>COMPLIANCE WITH EC DIRECTIVES 2. (B): Addition of servo motors</p> <p>Section 1.1: Correction to error in writing of HA-LF Standard models of HC-KF and HC-MF are made compliant with overseas standards.</p> <p>Section 1.2: Addition of servo motors</p> <p>Section 2.1: Change of vibration conditions</p> <p>Section 2.4 (9): Addition of sentence</p> <p>Section 2.5 (3): Deletion of Note 2</p> <p>Section 2.6 (2): Deletion of Note 2</p> <p>Section 3.1.3: Addition of servo motors</p> <p>Section 3.2: Addition of servo motors</p> <p>Section 5.1: Addition of servo motor specifications Deletion of HC-SF52 and MR-RB32 combinations Deletion of HC-SF53 and MR-RB32 combinations Change of the number of regenerative frequencies of HC-UF72 (previously 102, 305, 508 from top to bottom) Change of HC-KF series and HA-LF series servo amplifier combinations HA-LF30K2's previous rated current 83A, maximum current 208A, cooling fan rated current 0.32 (50Hz)/63 (50Hz) Deletion of HC-SFS52 and MR-RB32 combinations Deletion of HC-SFS53 and MR-RB32 combinations Deletion of HC-UFS72 and MR-RB32 combinations Addition of Note 13</p> <p>Section 5.2: Addition of torque characteristics</p> <p>Section 5.3 (1): Addition of servo motors</p> <p>Section 5.3 (2): Previous permissible load inertia moment HC-KF, HC-KFS: 25 times HC-MF, HC-MFS: 5 times</p> <p>Section 5.3 (4)(C) 1: Previously 2000 hours</p> <p>Section 5.3 (4)(C) 2: Previously 25000 hours at second time and later</p> <p>Section 5.4: Addition of servo motors</p> <p>Section 6.1 (1): HC-KF series 23B, 43B Previous permissible braking work done per braking 4500[N · Em] Previous permissible braking work done per braking 45000[N · Em]</p> <p>Section 7.1: Addition of servo motors</p>
Oct., 2002	SH(NA)3181-F	<p>Safety Instructions: Environmental condition table modification Addition of About processing of waste Addition of FOR MAXIMUM SAFETY Reexamination of table in COMPLIANCE WITH EC DIRECTIVES Addition of text to the UL/C-U Standards, addition of HA-LF, HA-LFS series</p> <p>Section 1.1: Addition of HA-FF, HA-LFS, HC-LFS, addition of Note sentences</p>

Print Data	*Manual Number	Revision
Oct., 2002	SH(NA)3181-F	<p>Section 1.2: Change/deletion of rating plate, addition of (o) HA-LFS series, addition of (p) HC-LFS series</p> <p>Section 1.2 (2) (i): Change of HA-LF series contents</p> <p>Section 1.3: Change of terminal box type motor diagram</p> <p>Chapter 2: Addition of CAUTION sentences, deletion of transportation item</p> <p>Section 2.1: Addition of HA-LFS, HC-LFS series</p> <p>Section 2.2: Addition of HA-LFS</p> <p>Section 2.3: Change of (6) into POINT</p> <p>Section 2.4: Addition of POINT, change of (3) text Addition of HC-KF, HC-KFS73, HA-LFS, HC-LFS</p> <p>Section 2.4.1: Addition</p> <p>Section 2.4.2: Addition</p> <p>Section 2.5: Addition of (6), (7), (8)</p> <p>Section 2.5 (1): Addition of HA-LFS, HC-LFS series</p> <p>Section 2.5 (2): Partial change of text, addition of HA-LFS, HC-LFS</p> <p>Section 2.5 (5): Partial change of text</p> <p>Section 2.6: Addition of HA-LFS</p> <p>Section 2.7: Change</p> <p>Section 3.1: Reexamination of table</p> <p>Section 3.1.3: Addition of HA-LFS, HC-LFS</p> <p>Section 3.1.6: Item addition</p> <p>Section 3.2: Addition of HA-LFS, HC-LFS series</p> <p>Section 3.3: Addition of HA-LFS, HC-LFS series</p> <p>Chapter 4: Addition of (d)</p> <p>Chapter 4 (2): Partial change of table</p> <p>Section 5.1: Reexamination of table Addition of HA-LF series 37K2 Addition of HC-MFS series, HC-KFS series compatible servo amplifiers Addition of HC-UFS series compatible servo amplifiers Addition of HA-LFS, HC-LFS series Reexamination of Note sentences</p> <p>Section 5.2: Partial deletion of POINT sentences, addition of items (10) to (13)</p> <p>Section 5.2 (1): Addition of POINT, reexamination of graph</p> <p>Section 5.2 (2): Addition of POINT, reexamination of graph</p> <p>Section 5.2 (5): Addition of POINT, reexamination of graph</p> <p>Section 5.2 (7): Change of HC-KF053 graph, reexamination of graph</p> <p>Section 5.3 (1): Addition of Note sentences</p> <p>Section 5.3 (2): Partial deletion of table</p> <p>Section 5.3 (4) (c): Change of title</p> <p>Section 5.4: Addition of HC-LFS series</p> <p>Section 5.4.1 (2): Addition of HC-LFS series</p> <p>Section 6.1: Addition of CAUTION sentences</p> <p>Section 6.1 (1): Addition of text, reexamination of table, addition of HC-LFS series</p> <p>Section 6.1 (2): Deletion of diagrams in (a), (b)</p> <p>Section 6.3: Addition</p> <p>Section 7.1: Addition of Note sentences, addition of text in With reduction gear</p> <p>Section 7.1.1 (3) (a): Change of BC12066, BC12067 outline drawings</p> <p>Section 7.1.1 (3) (b): Change of BC12071, BC12072 outline drawings</p> <p>Section 7.1.2 (4) (b): Partial change of HA-FF13BG2 inertia moment values</p> <p>Section 7.1.3 (3) (a): Partial reexamination of outline drawing sub numbers</p> <p>Section 7.1.3 (3) (b): Partial reexamination of outline drawing sub numbers</p> <p>Section 7.1.3 (4) (a): Partial reexamination of outline drawing sub numbers</p> <p>Section 7.1.3 (4) (b): Partial reexamination of outline drawing sub numbers</p>

Print Data	*Manual Number	Revision
Oct., 2002	SH(NA)3181-F	<p>Section 7.1.4 (2): Change of HC-RF(S)353B, HC-RF(S)503B variable dimensions</p> <p>Section 7.1.7: Addition of title</p> <p>Section 7.1.9: Reexamination of variable dimensions and inertia moment values, change of HC-AQ series outline drawings</p> <p>Section 7.1.10: Reexamination of terminal box detail drawings and tables, addition of HA-LF37K2 outline drawing</p> <p>Section 7.1.11 (1): Partial change of HC-KFS73 inertia moment values, partial reexamination of sub numbers</p> <p>Section 7.1.11 (3) (a): Change of BC11896, BC11897 outline drawings</p> <p>Section 7.1.11 (3) (b): Change of BC11901, BC11902 outline drawings</p> <p>Section 7.1.13: Addition of HA-LFS series outline drawings</p> <p>Section 7.1.14: Addition of item (addition of HC-LFS outline drawing)</p> <p>Section 7.2: Addition of POINT, addition of text in With reduction gear</p> <p>Section 7.2.1 (3) (a): Change of BC12066, BC12067 outline drawings</p> <p>Section 7.2.1 (3) (b): Change of BC12071, BC12072 outline drawings</p> <p>Section 7.2.2 (4) (b): Partial change of HA-FF13BG2 inertia moment values</p> <p>Section 7.2.3 (3) (a): Partial reexamination of outline drawing sub numbers</p> <p>Section 7.2.3 (3) (b): Partial reexamination of outline drawing sub numbers</p> <p>Section 7.2.3 (4) (a): Partial reexamination of outline drawing sub numbers</p> <p>Section 7.2.3 (4) (b): Partial reexamination of outline drawing sub numbers</p> <p>Section 7.2.4 (2): Change of HC-RF(S)353B, HC-RF(S)503B variable dimensions</p> <p>Section 7.2.7: Change of title</p> <p>Section 7.2.9: Reexamination of variable dimensions and inertia moment values, change of HC-AQ series outline drawings</p> <p>Section 7.2.10: Reexamination of terminal box detail drawings and tables, addition of HA-LF37K2 outline drawing</p> <p>Section 7.2.11 (1): Partial change of HC-KFS73 inertia moment values, partial reexamination of sub numbers</p> <p>Section 7.2.11 (3) (a): Change of BC11896, BC11897 outline drawings</p> <p>Section 7.2.11 (3) (b): Change of BC11901, BC11902 outline drawings</p> <p>Section 7.2.13: Addition of HA-LFS series outline drawings</p> <p>Section 7.2.14: Addition of item (addition of HC-LFS outline drawing)</p> <p>Section 7.3 (1): Addition of loose piece</p> <p>Section 7.3 (2) (b): Addition of Note sentences</p> <p>Section 7.3 (2) (d): Addition of Note sentences</p> <p>Section 7.3 (4): Addition</p> <p>Section 8.1: Reexamination of table</p> <p>Section 8.7: Addition</p> <p>Section 8.8: Reexamination of table</p> <p>Appendices: Addition of HA-LFS, HC-LFS series</p>
Jun., 2003	SH(NA)3181-G	<p>Safety Instructions: Addition of 400VAC compatible HA-LFS and 400VAC compatible HC-SFS to Environmental Condition table</p> <p>Addition of 400VAC compatible HC-SFS to 2. in COMPLIANCE WITH EC DIRECTIVES</p> <p>Addition of 400VAC compatible HA-LFS and 400VAC compatible HC-SFS to COMFORMANCE WITH UL/C-UL STANDARD</p> <p>Section 1.1: Addition of 400VAC compatible HA-LFS and 400VAC compatible HC-SFS, and reexamination of whole table</p> <p>Addition of (6), (7), (8)</p> <p>Section 1.2: Rating plate change</p> <p>Section 1.2 (I): Addition of 400VAC compatible HC-SFS</p> <p>Section 1.2 (O): Addition of electromagnetic brake/shaft type to 200VAC compatible HA-LFS, addition of 400VAC compatible HA-LFS</p>

Print Data	*Manual Number	Revision
Jun., 2003	SH(NA)3181-G	<p>Chapter 2: Partial change of CAUTION sentence</p> <p>Section 2.1: Addition of 400VAC compatible HA-LFS and 400VAC compatible HC-SFS to Environmental Condition table</p> <p>Section 2.4: Addition of Item (4)</p> <p>Section 2.4.1: Addition of 400VAC compatible HA-LFS and 400VAC compatible HC-SFS, addition of Note 3</p> <p>Section 2.4.2 (3): Addition of 400VAC compatible HC-SFS</p> <p>Section 2.4.2 (4): Permissible thrust load1/20 value change</p> <p>Section 2.5 (2): Addition of 400VAC compatible HA-LFS and 400VAC compatible HC-SFS</p> <p>Section 2.6: Addition of 400VAC compatible HA-LFS</p> <p>Section 3.1.3: Addition of 400VAC compatible HA-LFS and 400VAC compatible HC-SFS</p> <p>Section 3.2: Addition of 400VAC compatible HC-SFS</p> <p>Section 5.1: Reexamination of whole table, addition of 400VAC compatible HA-LFS and 400VAC compatible HC-SFS, partial change of Note 10, addition of Note 14, 15, 16</p> <p>Section 5.2: Addition of POINT sentence</p> <p>Section 5.2 (3): Addition of 400VAC compatible HC-SFS, HC-SF(S)81/102/202/103 graph change</p> <p>Section 5.2 (5): HC-UF(S)72/152 graph change</p> <p>Section 5.2 (9): Addition of HA-LF37K2</p> <p>Section 5.2 (10): Addition of 400VAC compatible HA-LFS, HA-LFS15K1 graph change</p> <p>Section 5.3: Addition of 400VAC compatible HC-SFS</p> <p>Section 5.4: Addition of HA-LF series, HA-LFS series and 400VAC compatible HC-SFS</p> <p>Section 5.4.1: Reexamination, key-less table change</p> <p>Section 6.1 (1): Addition of 400VAC compatible HC-SFS, addition of HA-LFS series, addition of Note 7</p> <p>Section 6.3: Partial reexamination</p> <p>Section 7.1.3: Addition of 400VAC compatible HC-SFS</p> <p>Section 7.1.10: Terminal box detail diagram change</p> <p>Section 7.1.13: Terminal box detail diagram change, addition of 400VAC compatible HA-LFS, overall reexamination, addition of model with electromagnetic brake</p> <p>Section 7.2.3: Addition of 400VAC compatible HC-SFS</p> <p>Section 7.2.10: Terminal box detail diagram change</p> <p>Section 7.2.13: Terminal box detail diagram change, addition of 400VAC compatible HA-LFS, overall reexamination, addition of model with electromagnetic brake</p> <p>Appendices: Addition of 400VAC compatible HA-LFS and 400VAC compatible HC-SFS to servo motor ID codes</p>
Sep., 2003	SH(NA)3181-H	<p>Safety Instructions: Partial change of text in 3</p> <p>Addition of HC-SFS524, 1024, 1524, 2024 and 7024, and HA-LFS6014 and 701M4 to the environment condition table</p> <p>Addition of HC-SFS524, 1024, 1524, 2024 and 7024 to the table in (b) of COMPLIANCE WITH EC DIRECTIVES</p> <p>Addition of HC-SFS524, 1024, 1524, 2024 and 7024, and HA-LFS6014 and 701M4 and addition of Note to the UL/C-UL STANDARD</p> <p>Section 1.1: Change of the capacities supported by HC-SFS400V and partial change of the capacities supported by HA-LFS400V</p> <p>Section 1.2 (2) (l) 2): Rated output addition</p> <p>Section 1.2 (2) (o) 2): Rated output addition</p>

Print Data	*Manual Number	Revision
Sep., 2003	SH(NA)3181-H	<p>Section 2.1: Addition of HC-SFS524, 1024, 1524, 2024 and 7024, and HA-LFS6014 and 701M4 to the environment condition table</p> <p>Section 2.4.1: Addition of HC-SFS524, 1024, 1524, 2024 and 7024, and HA-LFS6014 and 701M4, change of Note 3 sentence</p> <p>Partial addition of Note</p> <p>Section 2.4.2 (3) (a): Addition of HC-SFS524(B)G1, 1024(B)G1, 1524(B)G1, 2024(B)G1 and 7024(B)G1</p> <p>Section 2.4.2 (3) (b): Addition of HC-SFS524(B)G2, 1024(B)G2, 1524(B)G2, 2024(B)G2 and 7024(B)G2</p> <p>Section 2.5 (2): Addition of HC-SFS524, 1024, 1524, 2024 and 7024, and HA-LFS6014 and 701M4</p> <p>Section 2.6: Addition of HA-LFS6014 and 701M4</p> <p>Section 3.1.3: Addition of HC-SFS524, 1024, 1524, 2024 and 7024, and HA-LFS6014 and 701M4</p> <p>Section 3.2: Addition of HC-SFS524, 1024, 1524, 2024 and 7024</p> <p>Section 5.1: Addition of HC-SFS524, 1024, 1524, 2024 and 7024, and HA-LFS6014 and 701M4, addition of Note 14 to HA-LFS200V/400V table, reexamination of HA-LFS25K14 regenerative brake duty</p> <p>Section 5.2 (3) (b): Addition of HC-SFS524, 1024, 1524, 2024 and 7024</p> <p>Section 5.2 (10) (b): Change of Note 1</p> <p>Section 5.3: Addition of HC-SFS524, 1024, 1524, 2024 and 7024</p> <p>Section 5.3 (2): Partial change of table contents</p> <p>Section 5.4: Addition of HC-SFS524, 1024, 1524, 2024 and 7024</p> <p>Section 5.4.1 (2): Addition of HC-SFS524K, 1024K, 1524K, 2024K and 7024K, and HA-LFS6014K and 701M4K</p> <p>Section 6.1: Addition of HC-SFS524B, 1024B, 1524B, 2024B and 7024B, and HA-LFS6014B and 701M4B, change of Note 7, addition of (4)</p> <p>Section 6.1 (1): Partial change</p> <p>Section 7.1.3: Addition of HC-SFS524, 1024, 1524, 2024 and 7024</p> <p>Section 7.1.13: Addition of HA-LFS6014 and 701M4, partial addition of Note</p> <p>Section 7.2.3: Addition of HC-SFS524, 1024, 1524, 2024 and 7024</p> <p>Section 7.2.13: Addition of HA-LFS6014 and 701M4, partial addition of Note</p> <p>Appendix: Addition of HC-SFS524, 1024, 1524, 2024 and 7024, and HA-LFS6014 and 701M4</p>
Oct., 2004	SH(NA)3181-J	<p>Safety Instructions 4 (1): Note change</p> <p>4 (5): Circuit diagram change</p> <p>Section 1.1: HC-UF, HC-UFS, HC-AQ feature representation change</p> <p>Section 1.2 (2): Remarks addition and change to the axis type field of (a) to (e), (g), (h), (i) to (o), item addition to (j) axis type field, and axis type addition to (p)</p> <p>Section 3.1.3 (2): (a)-3, (b)-3 Servo motor model addition</p> <p>Section 5.1: Speed/position detection, equipment item contents change, HC-UF 3000 revolutions MR-J2 series regenerative brake duty, HC-SFS 2000 revolutions instantaneous revolution permissible speed, and rated current value were changed, HC-SFS series, HC-UFS 3000 revolutions regenerative brake duty change, HA-LFS 1000 revolutions, 1500 revolutions, 2000 revolutions 37K rated output contents addition, HA-LFS 1000 revolutions rated current change, HA-LFS6014 regenerative brake duty change, addition of MR-RB54-4 to the regenerative brake duty item, MR-RB34-4, MR-RB54-4 addition and rated current value change to the regenerative brake duty item of HA-LFS 1500 revolutions, HA-LFS 2000 revolutions rated current value change, HC-LFS series compatible servo amplifier change</p> <p>Section 5.2: Operation in graph changed to running.</p>

Print Data	*Manual Number	Revision
Oct., 2004	SH(NA)3181-J	<p>Section 5.2 (3): Remarks addition Graph change to HC-SF(S)52, HC-SF(S)102, HC-SF(S)152, HC-SF(S)202, HC-SF(S)702 in (a) and HC-SFS524, HC-SFS1024, HC-SFS1524, HC-SFS2024, HC-SFS3524, HC-SFS7024 in (b)</p> <p>Section 5.2 (4): HC-RF(S)203, HC-RF(S)503 graph change</p> <p>Section 5.2 (5): HC-UF(S)202 graph change</p> <p>Section 5.2 (10): HA-LFS15K1M, HA-LFS22K2 graph change in (a), HA-LFS15K14 addition and HA-LFS30K14, HA-LFS37K14, HA-LFS11K1M4, HA-LFS15K1M4, HA-LFS22K1M4, HA-LFS30K1M4, HA-LFS37K1M4, HA-LFS45K1M4, HA-LFS50K1M4, HA-LFS15K24, HA-LFS22K24, HA-LFS45K24 graph change in (b)</p> <p>Section 5.3 (2): Remarks addition</p> <p>Section 5.3 (3): Remarks addition</p> <p>Section 5.3 (4): Remarks addition, text change</p> <p>Section 5.3 (5): Remarks addition</p> <p>Section 6.1: Correction to mistakes in writing</p> <p>Section 6.1 (2): Circuit diagram change</p> <p>Section 6.1 (4): Text addition</p> <p>Section 7.1.4: Text addition</p> <p>Section 7.1.11: Text addition</p> <p>Section 7.1.13 (1): Deletion of Note 3 from HA-LFS15K1, etc., addition of Note 3 to HA-LFS25K1</p> <p>Section 7.1.13 (4)(b): Correction to mistakes in writing</p> <p>Section 7.2.11 (4)(b): Correction to mistakes in writing</p> <p>Section 8.1: Item deletion</p> <p>Appendices: Memo page deletion</p>
Dec., 2005	SH(NA)3181-K	<p>Safety Instructions (2): A precaution for wiring is added (4): A precaution for usage is added</p> <p>Service life of this product: added</p> <p>Service life of EEPROM: added</p> <p>Guarantee: added</p> <p>Conformance with UL/C-UL standard: Partially changed</p> <p>Section 5.1: HA-LF37K2 clerical error on rated current is modified to 204A, and maximum current is modified to 510A HC-KF23 · 43 clerical error on power rate at continuous rated torque is modified HC-KF23 · 43 clerical error on inertia moment ratio is modified HC-KF23 · 43 recommended load inertia moment ratio to a servo motor axis is modified HC-KFS23 · 43 clerical error on power rate at continuous rated torque is modified HC-KFS23 · 43 clerical error on inertia moment ratio is modified HC-KFS23 · 43 recommended load inertia moment ratio to a servo motor axis is modified</p> <p>Section 5.3 (2): Note about reduction ratio of the reduction gear is added</p> <p>Section 5.3 (3): Note about reduction ratio of the reduction gear is added</p> <p>Section 5.3 (4): Note about reduction ratio of the reduction gear is added</p> <p>Section 5.3 (5): Note about reduction ratio of the reduction gear is added</p> <p>Section 5.3 (4)(b): Point is added</p> <p>Chapter 7: Braking force is changed to static friction torque</p> <p>Section 7.1.1: HC-KF23 · 43 clerical error on inertia moment ratio is modified</p> <p>Section 7.1.2 (4)(b): Clerical error is modified</p> <p>Section 7.1.2 (5)(a): Clerical error is modified</p> <p>Section 7.1.2 (5)(b): Clerical error is modified</p> <p>Section 7.1.3 (3): Clerical error is modified</p>

Print Data	*Manual Number	Revision
Dec., 2005	SH(NA)3181-K	<p>Section 7.1.4 (3)(a): Clerical error is modified</p> <p>Section 7.1.11 (1): HC-KFS23 · 43 clerical error on inertia moment ratio is modified</p> <p>Section 7.1.11 (2): HC-KFS23 · 43 clerical error on inertia moment ratio is modified</p> <p>Section 7.1.11 (3): HC-KFS23 · 43 clerical error on inertia moment ratio is modified</p> <p>Section 7.1.11 (4): HC-KFS23 · 43 clerical error on inertia moment ratio is modified</p> <p>Section 7.1.13: Detailed drawing of terminal box is reviewed</p> <p>Section 7.2.1 (1): HC-KF23 · 43 clerical error on inertia moment ratio is modified</p> <p>Section 7.2.1 (2): HC-KF23 · 43 clerical error on inertia moment ratio is modified</p> <p>Section 7.2.1 (3): HC-KF23 · 43 clerical error on inertia moment ratio is modified</p> <p>Section 7.2.1 (4): HC-KF23 · 43 clerical error on inertia moment ratio is modified</p> <p>Section 7.2.1 (5): HC-KF23 · 43 clerical error on inertia moment ratio is modified</p> <p>Section 7.2.2 (5): Clerical error is modified</p> <p>Section 7.2.3 (3): Clerical error is modified</p> <p>Section 7.2.3 (5): Clerical error is modified</p> <p>Section 7.2.4 (3): Clerical error is modified</p> <p>Section 7.2.5 (1): Clerical error is modified</p> <p>Section 7.2.11 (2): HC-KF23 · 43 Clerical error on inertia moment ratio is modified</p> <p>Section 7.2.11 (3): HC-KF23 · 43 Clerical error on inertia moment ratio is modified</p> <p>Section 7.2.11 (4): HC-KF23 · 43 Clerical error on inertia moment ratio is modified</p> <p>Section 7.2.13: Detailed drawing of terminal box is reviewed</p>
May, 2008	SH(NA)3181-L	<p>Safety Instructions</p> <p>1. To prevent electric shock: WARNING: Partial change of sentence</p> <p>2. To prevent fire: CAUTION: Partial change of sentence</p> <p>4. Additional Instructions</p> <p>(2) Wiring: CAUTION: Addition of diagram and sentence</p> <p>(5) Corrective actions: Circuit diagram change</p> <p>COMPLIANCE WITH EC DIRECTIVE: (3) Addition of performing EMC tests</p> <p>Section 1.2 (2)(a): Rated output unit changed to [kW]</p> <p>Chapter 2: CAUTION: Partial change of sentence</p> <p>Section 2.6: Partial change of servo motor list</p> <p>Section 3.1: DDK connectors changed to RoHS compatible</p> <p>Section 3.2: DDK connectors changed to RoHS compatible</p> <p>Section 4.1: Addition of a sentence in WARNING reminding about confirmation of powering off charge lamp</p> <p>Section 5.1: Change of specifications of HA-LFS series and cooling fan power supply and current</p> <p>Section 5.2: Addition of 400VAC compatible HA-LFS series graph</p> <p>Section 5.3: Change of HC series permissible load inertia moment ratio</p> <p>Section 5.4: Partial change of shaft dimensions</p> <p>Section 5.4.1 (2): Key shaft (QK) dimensions of HC-UF/UFS (152K, 202K to 502K) modified</p> <p>Section 6.1: Addition of diagram and sentence</p>

Print Data	*Manual Number	Revision
May, 2008	SH(NA)3181-L	<p>Section 7.1.3 (3): Change of outline drawings Note added "HC-SFS52G1H 102G1H 152G1H 524G1H 1024G1H 1524G1H" "HC-SFS52G1H 524G1H" "HC-SFS202G1H 2024G1H" "HC-SFS52BG1H 102BG1H 152BG1H 524BG1H 1024BG1H 1524BG1H" "HC-SFS52BG1H 524BG1H" "HC-SFS202BG1H 2024BG1H" "HC-SFS52G1 102G1 152G1 524G1 1024G1 1524G1" "HC-SFS52G1 524G1" "HC-SFS202G1 2024G1" "HC-SFS52BG1 102BG1 152BG1 524BG1 1024BG1 1524BG1" "HC-SFS52BG1 524BG1" "HC-SFS202BG1 2024BG1"</p> <p>Section 7.1.13: Partial change of terminal box detail diagram Section 7.1.13 (1): Change of outline drawings "HA-LFS8014 11K1M 11K1M4 15K2 15K24" "HA-LFS12K1 12K14 15K1M 15K1M4 22K2 22K24" "HA-LFS15K1 15K14 22K1M 22K1M4 30K24" "HA-LFS20K1 20K14 30K1M4 37K24" "HA-LFS25K1 25K14 37K1M 37K1M4 45K24" "HA-LFS30K1 30K14 45K1M4 55K24" "HA-LFS37K1 37K14 50K1M4" "HA-LFS30K1M 37K2" "HA-LFS30K2" "HA-LFS801B 8014B 11K1MB 11K1M4B 15K2B 15K24B 12K1B 12K14B 15K1MB 15K1M4B 22K2B 22K24B"</p> <p>Section 7.2.3 (3): Change of same outline drawings as Section 7.1.3 (3) Section 7.2.13: Partial change of terminal box detail diagram Section 7.2.13 (1): Change of same outline drawings as Section 7.1.13 (1) Section 7.3: DDK connectors changed to RoHS compatible App. 2: Addition of RoHS compatible connector sets list</p>

MODEL	MOTOR INSTRUCTION
MODEL CODE	1CW940



MITSUBISHI ELECTRIC CORPORATION

HEAD OFFICE : TOKYO BLDG MARUNOUCHI TOKYO 100-8310