

MANUAL

TRANSMISSION

MODEL R5M3, V5M3

CONTENTS

GENERAL INFORMATION	22C-0-3
1. SPECIFICATIONS	22C-1-1
TRANSMISSION MODEL TABLE	22C-1-1
GENERAL SPECIFICATIONS	22C-1-2
SERVICE SPECIFICATIONS	22C-1-2
TORQUE SPECIFICATIONS	22C-1-3
SEALANTS	22C-1-4
LUBRICANTS	22C-1-5
ADJUSTMENT SNAP RINGS AND SPACERS	22C-1-5
2. SPECIAL TOOLS	22C-2-1
3. TRANSMISSION	22C-3-1
4. MAIN DRIVE PINION	22C-4-1
5. COUNTERSHAFT CLUSTER GEAR	22C-5-1
6. MAIN SHAFT	22C-6-1
7. TRANSFER <V5M31>	22C-7-1
7a. TRANSFER <V5M31 – SUPER SELECT 4WD II>	22C-7a-1
8. TRANSFER CASE PLATE <V5M31>	22C-8-1
9. TRANSFER INPUT GEAR <V5M31 – PART TIME 4WD AND SUPER SELECT 4WD>	22C-9-1
9a. TRANSFER INPUT GEAR <V5M31 – SUPER SELECT 4WD II>	22C-9a-1
10. COUNTERSHAFT GEAR <V5M31 – PART TIME 4WD AND SUPER SELECT 4WD>	22C-10-1
10a. COUNTERSHAFT GEAR <V5M31 – SUPER SELECT 4WD II>	22C-10a-1
11. H-L SHIFT FORK <V5M31 – PART TIME 4WD AND SUPER SELECT 4WD>	22C-11-1
11a. SHIFT FORK AND SHIFT RAIL <V5M31 – SUPER SELECT 4WD II> ...	22C-11a-1
12. 2-4WD SYNCHRONIZER <V5M31 – SUPER SELECT 4WD>	22C-12-1
13. CENTER DIFFERENTIAL CASE <V5M31 – SUPER SELECT 4WD>	22C-13-1

14.	REAR OUTPUT SHAFT <V5M31 – SUPER SELECT 4WD>	22C-14-1
14a.	REAR OUTPUT SHAFT <V5M31 – SUPER SELECT 4WD II>	22C-14a-1
15.	REAR OUTPUT SHAFT <V5M31 – PART TIME 4WD>	22C-15-1
16.	TRANSFER DRIVE SHAFT <V5M31 – SUPER SELECT 4WD>	22C-16-1
16a.	TRANSFER DRIVE SHAFT <V5M31 – SUPER SELECT 4WD II>	22C-16a-1
17.	FRONT OUTPUT SHAFT <V5M31 – PART TIME 4WD AND SUPER SELECT 4WD>	22C-17-1
17a.	FRONT OUTPUT SHAFT <V5M31 – SUPER SELECT 4WD II>	22C-17a-1
18.	SPEEDOMETER GEAR <R5M31, V5M31 – PART TIME 4WD AND SUPER SELECT 4WD>	22C-18-1
19.	CONTROL HOUSING <R5M31>	22C-19-1
20.	SHIFT RAIL DRIVE GEAR <V5M31 – SUPER SELECT 4WD II>	22C-20-1

GENERAL INFORMATION

V5M31-5 <SUPER SELECT 4WD>

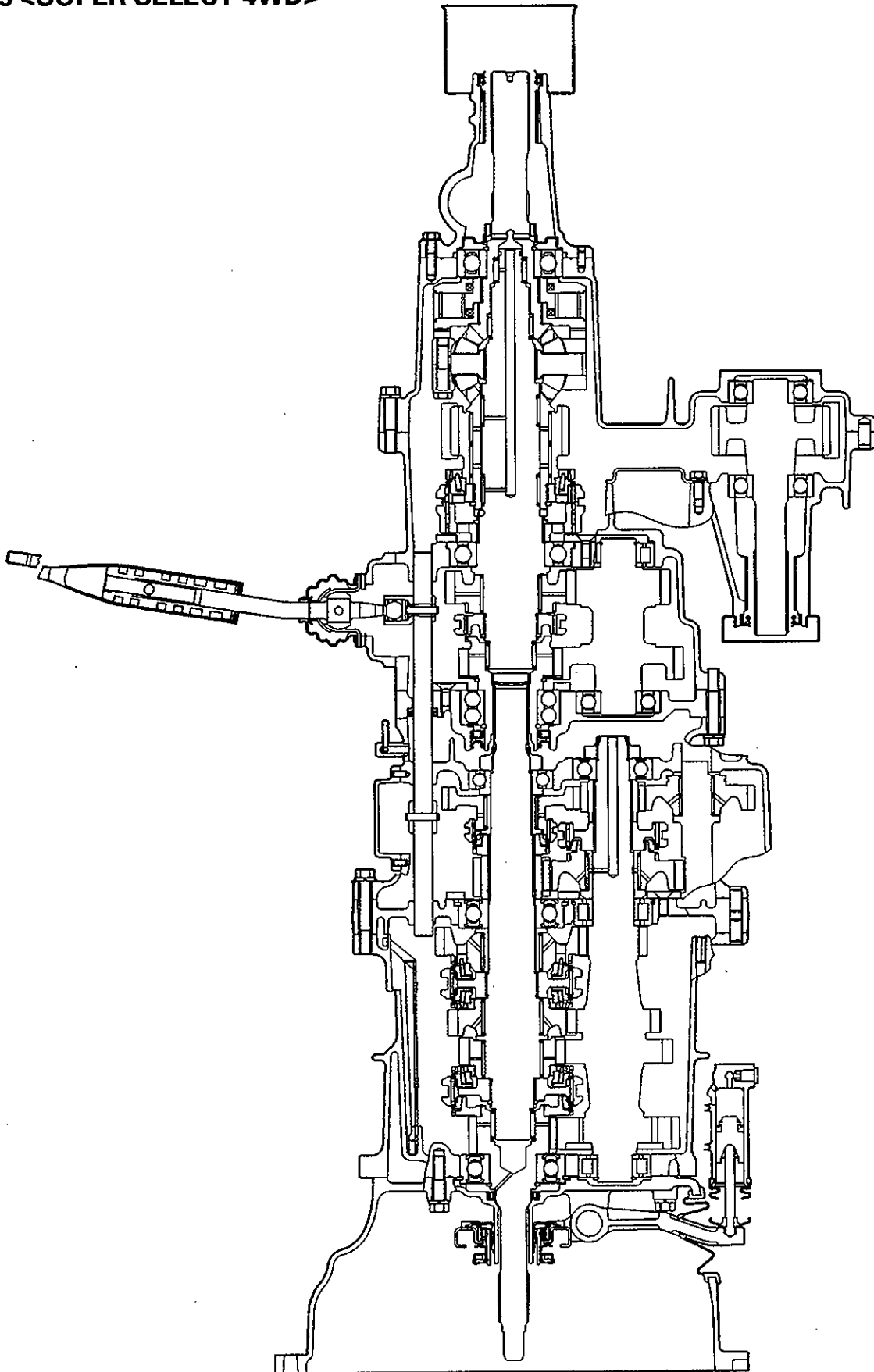

TRM0784

V5M31-5 <PART TIME 4WD>

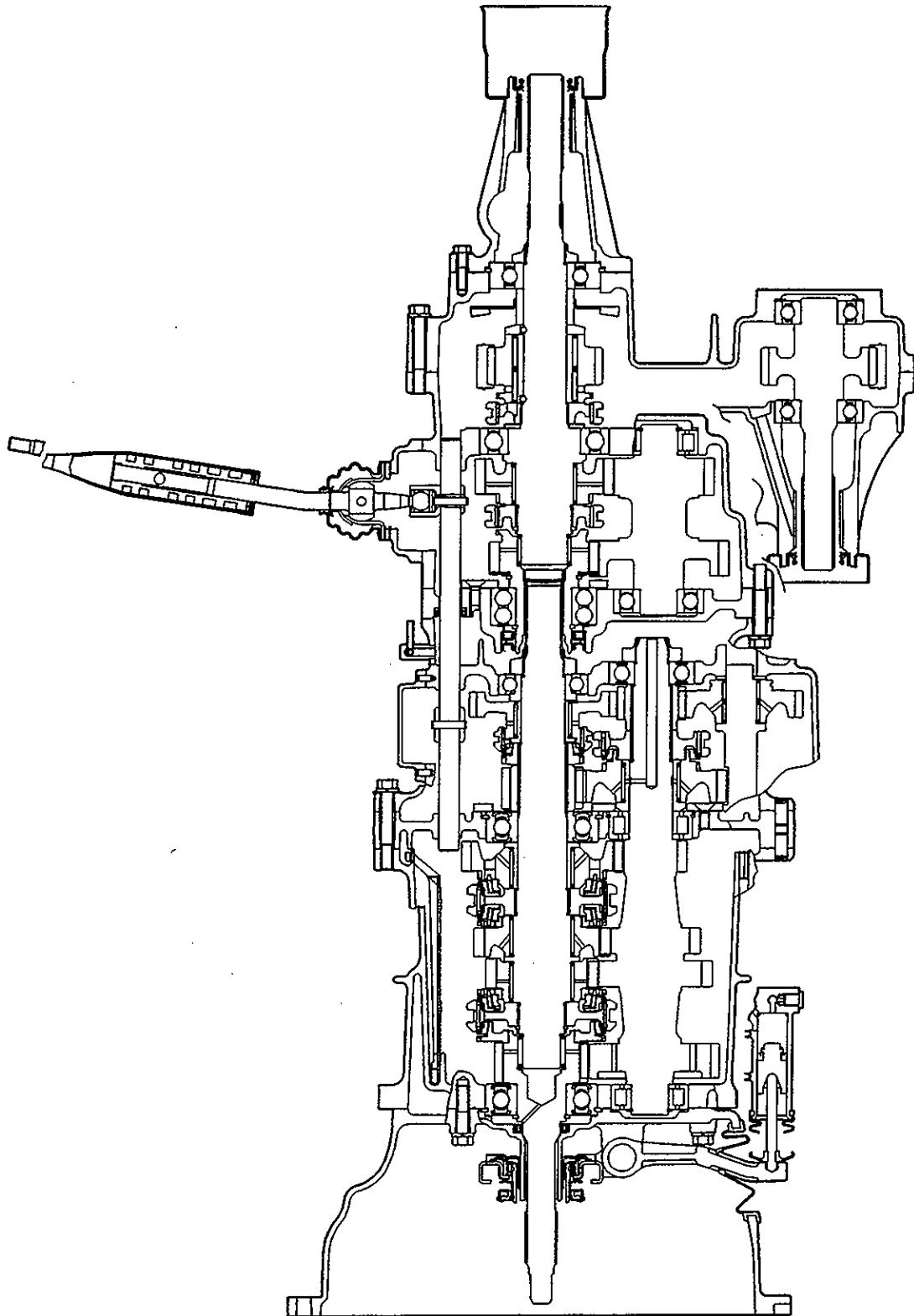

V5M31-6 <SUPER SELECT 4WD II>

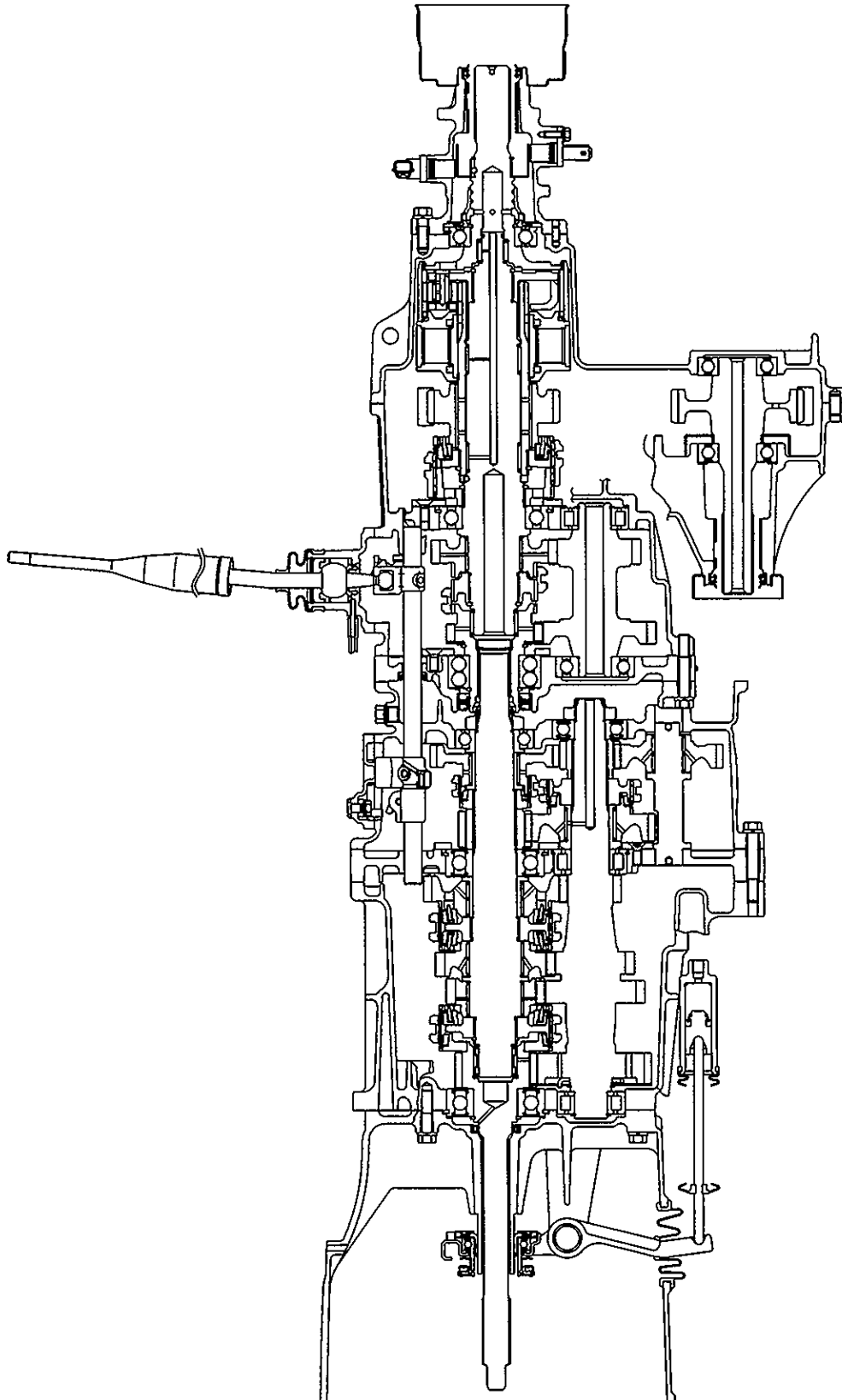

V5M31-6 <PART TIME 4WD>

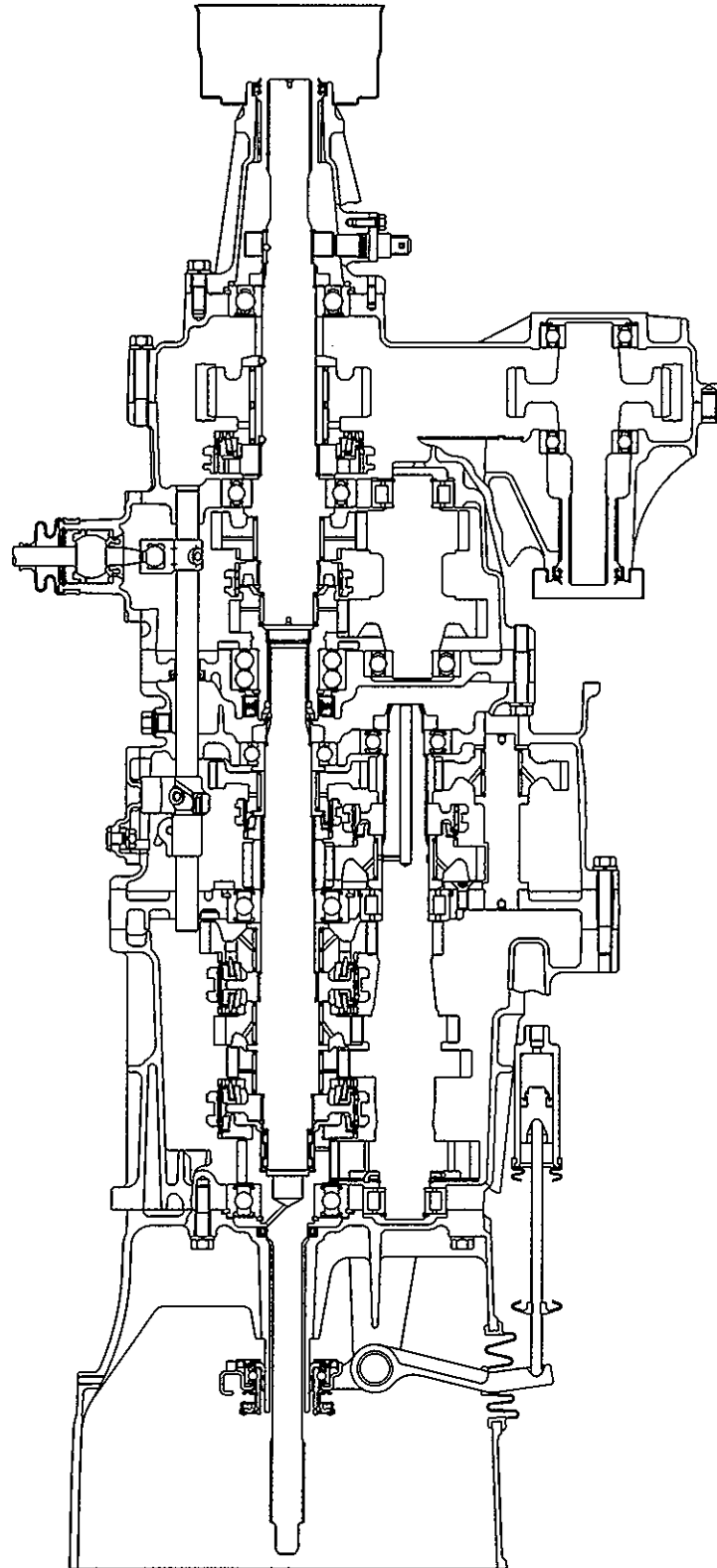

R5M31

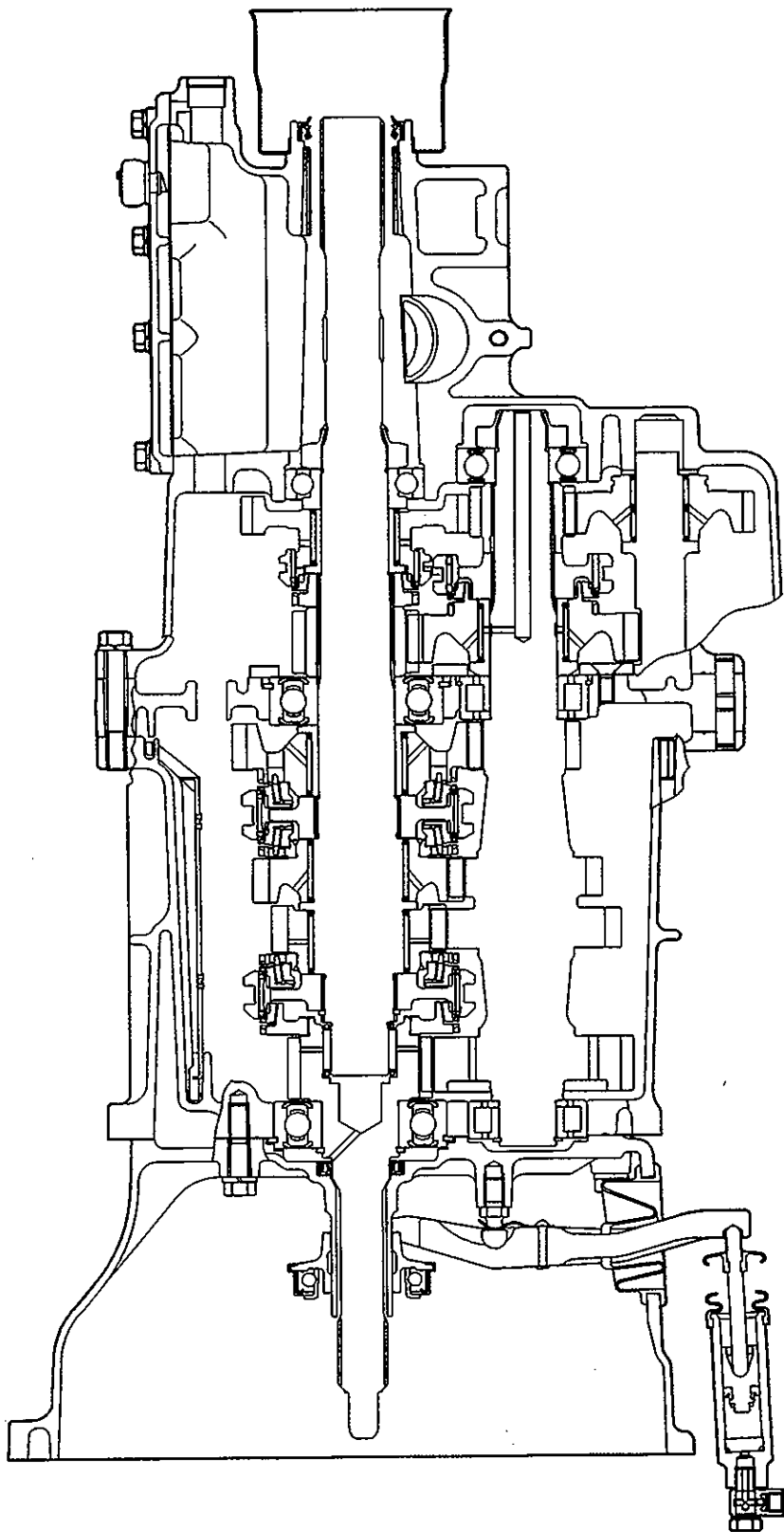

TRM0786

NOTES

1. SPECIFICATIONS

TRANSMISSION MODEL TABLE – MODEL 1994

	Transmission model	Speedometer gear ratio	Vehicle model	Engine model
EC	V5M31-5-SJ	30/9	PAJERO/MONTERO	4M40 Turbocharger with charge air cooler
	V5M31-5-SJL	30/9	PAJERO/MONTERO	4M40 Turbocharger with charge air cooler
	V5M31-5-SJTL	30/9	PAJERO/MONTERO	4M40 Turbocharger with charge air cooler
	V5M31-5-YH	28/9	PAJERO/MONTERO	6G74
	V5M31-5-YHL	28/9	PAJERO/MONTERO	6G74
EXP	V5M31-5-SI	29/9	PAJERO/MONTERO	4M40 Turbocharger with charge air cooler
	V5M31-5-SIL	29/9	PAJERO/MONTERO	4M40 Turbocharger with charge air cooler
	V5M31-5-YH	28/9	PAJERO/MONTERO	6G74
	V5M31-5-YHL	28/9	PAJERO/MONTERO	6G74
AUS	V5M31-5-SJ	30/9	PAJERO	4M40 Turbocharger with charge air cooler
	V5M31-5-YH	28/9	PAJERO	6G74

TRANSMISSION MODEL TABLE – MODEL 1995

	Transmission model	Speedometer gear ratio	Vehicle model	Engine model
EC	R5M31-7-NI	29/9	L400-2WD	4D56 Turbocharger with charge air cooler
	V5M31-5-SH	28/9	PAJERO/MONTERO	4M40 Turbocharger with charge air cooler
	V5M31-5-SHL	28/9	PAJERO/MONTERO	4M40 Turbocharger with charge air cooler
	V5M31-5-SJ	30/9	PAJERO/MONTERO	4M40 Turbocharger with charge air cooler
	V5M31-5-SJL	30/9	PAJERO/MONTERO	4M40 Turbocharger with charge air cooler
	V5M31-5-SJTL	30/9	PAJERO/MONTERO	4M40 Turbocharger with charge air cooler
	V5M31-5-YH	28/9	PAJERO/MONTERO	6G74
	V5M31-5-YHL	28/9	PAJERO/MONTERO	6G74
	V5M31-7-NKL	31/9	L400-4WD	4D56 Turbocharger with charge air cooler
EXP	V5M31-5-SHI	28/9	PAJERO/MONTERO	4M40 Turbocharger with charge air cooler
	V5M31-5-SIL	29/9	PAJERO/MONTERO	4M40 Turbocharger with charge air cooler
	V5M31-5-SJL	30/9	PAJERO/MONTERO	4M40 Turbocharger with charge air cooler
	V5M31-5-SKL	31/9	PAJERO/MONTERO	4M40 Turbocharger with charge air cooler
	V5M31-5-SKT	31/9	PAJERO/MONTERO	4M40 Turbocharger with charge air cooler
	V5M31-5-YG	27/9	PAJERO/MONTERO	6G74
	V5M31-5-YGL	27/9	PAJERO/MONTERO	6G74
	V5M31-5-YH	28/9	PAJERO/MONTERO	6G74
	V5M31-5-YHL	28/9	PAJERO/MONTERO	6G74
AUS	V5M31-5-SJ	30/9	PAJERO/MONTERO	4M40 Turbocharger with charge air cooler

TRANSMISSION MODEL TABLE - MODEL 1996

	Transmission model	Speedometer gear ratio	Vehicle model	Engine model
EC	R5M31-7-NI	29/9	L400-2WD	4D56
	R5M31-7-NIL	29/9	L400-2WD	4D56
	V5M31-5-SH	28/9	PAJERO/MONTERO	4M40 Turbocharger with charge air cooler
	V5M31-5-SHL	28/9	PAJERO/MONTERO	4M40 Turbocharger with charge air cooler
	V5M31-5-SI	29/9	PAJERO/MONTERO	4M40 Turbocharger with charge air cooler
	V5M31-5-SIL	29/9	PAJERO/MONTERO	4M40 Turbocharger with charge air cooler
	V5M31-5-SJ	30/9	PAJERO/MONTERO	4M40 Turbocharger with charge air cooler
	V5M31-5-SJL	30/9	PAJERO/MONTERO	4M40 Turbocharger with charge air cooler
	V5M31-5-SJTL	30/9	PAJERO/MONTERO	4M40 Turbocharger with charge air cooler
	V5M31-7-NKL	31/9	L400-4WD	4D56
EXP	V5M31-5-DIL	29/9	PAJERO/MONTERO	4M40 Turbocharger with charge air cooler
	V5M31-5-REA	25/9	PAJERO/MONTERO	4M40 Turbocharger with charge air cooler
	V5M31-5-REAL	25/9	PAJERO/MONTERO	4M40 Turbocharger with charge air cooler
	V5M31-5-RGA	27/9	PAJERO/MONTERO	4M40 Turbocharger with charge air cooler
	V5M31-5-RGAL	27/9	PAJERO/MONTERO	4M40 Turbocharger with charge air cooler
	V5M31-5-SHT	28/9	PAJERO/MONTERO	4M40 Turbocharger with charge air cooler
	V5M31-5-SI	29/9	PAJERO/MONTERO	4M40 Turbocharger with charge air cooler
	V5M31-5-SIL	29/9	PAJERO/MONTERO	4M40 Turbocharger with charge air cooler
	V5M31-5-SKT	31/9	PAJERO/MONTERO	4M40 Turbocharger with charge air cooler
	V5M31-5-YG	27/9	PAJERO/MONTERO	6G74
	V5M31-5-YGL	27/9	PAJERO/MONTERO	6G74
	V5M31-5-YH	28/9	PAJERO/MONTERO	6G74
	V5M31-5-YHL	28/9	PAJERO/MONTERO	6G74
AUS	V5M31-5-SI	29/9	PAJERO	4M40 Turbocharger with charge air cooler
	V5M31-5-SJ	30/9	PAJERO	4M40 Turbocharger with charge air cooler

TRANSMISSION MODEL TABLE - MODEL 1997

	Transmission model	Speedometer gear ratio	Vehicle model	Engine model
EUR	R5M31-7-NG	27/9	L400-2WD	4D56
	R5M31-7-NGDL	27/9	L400-2WD	4D56
	V5M31-7-NIL	29/9	L400-4WD	4D56
	V5M31-5-YEL	25/9	PAJERO/MONTERO	6G74
	V5M31-5-YF	26/9	PAJERO/MONTERO	6G74
	V5M31-5-YFL	26/9	PAJERO/MONTERO	6G74
EXP	V5M31-5-YG	27/9	PAJERO/MONTERO	6G74
	V5M31-5-YGL	27/9	PAJERO/MONTERO	6G74
	V5M31-5-YH	28/9	PAJERO/MONTERO	6G74
	V5M31-5-YHL	28/9	PAJERO/MONTERO	6G74
AUS	V5M31-5-YG	27/9	PAJERO/MONTERO	6G74
	V5M31-5-YI	29/9	PAJERO/MONTERO	6G74

TRANSMISSION MODEL TABLE - MODEL 1998, 1999

	Transmission model	Speedometer gear ratio	Vehicle model	Engine model
EUR	R5M31-7-NGDL	27/9	L400-2WD	4D56
	V5M31-7-NIL	29/9	L400-4WD	4D56
	V5M31-5-YEL	25/9	PAJERO/MONTERO	6G74
	V5M31-5-YFL	26/9	PAJERO/MONTERO	6G74
	V5M31-5-YF	26/9	PAJERO/MONTERO	6G74
EXP	V5M31-5-YEL	25/9	PAJERO/MONTERO	6G74
	V5M31-5-YGL	27/9	PAJERO/MONTERO	6G74
	V5M31-5-YG	27/9	PAJERO/MONTERO	6G74
	V5M31-5-YHL	28/9	PAJERO/MONTERO	6G74
AUS	V5M31-5-YG	27/9	PAJERO/MONTERO	6G74
	V5M31-5-YI	29/9	PAJERO/MONTERO	6G74

TRANSMISSION MODEL TABLE - MODEL 2000

	Transmission model	Speedometer gear ratio	Vehicle model	Engine model
EUR	R5M31-7-NGDL	27/9	L400-2WD	4D56
	V5M31-7-NIL	29/9	L400-4WD	4D56
	V5M31-5-YEL	25/9	PAJERO/MONTERO	6G74
	V5M31-5-YFL	26/9	PAJERO/MONTERO	6G74
	V5M31-5-YF	26/9	PAJERO/MONTERO	6G74
	V5M31-5-SH	28/9	PAJERO/MONTERO	4M40
	V5M31-5-SHL	28/9	PAJERO/MONTERO	4M40
	V5M31-5-SHTL	28/9	PAJERO/MONTERO	4M40
	V5M31-5-SI	29/9	PAJERO/MONTERO	4M40
	V5M31-5-SIL	29/9	PAJERO/MONTERO	4M40
	V5M31-5-SJ	30/9	PAJERO/MONTERO	4M40
	V5M31-5-SJL	30/9	PAJERO/MONTERO	4M40
	V5M31-5-SJTL	30/9	PAJERO/MONTERO	4M40
EXP	R5M31-B-MFDL	26/9	L200-2WD	6G72
	R5M31-B-MHDL	28/9	L200-2WD	6G72
	V5M31-5-YEL	25/9	PAJERO/MONTERO	6G74
	V5M31-5-YGL	27/9	PAJERO/MONTERO	6G74
	V5M31-5-SI	29/9	PAJERO/MONTERO	4M40
	V5M31-5-SIL	29/9	PAJERO/MONTERO	4M40
	V5M31-5-SKT	31/9	PAJERO/MONTERO	4M40
	V5M31-5-SHT	28/9	PAJERO/MONTERO	4M40
	V5M31-B-SIGL	29/9	L200-4WD	4M40
	V5M31-B-SIGL	29/9	L200-4WD	4M40
AUS	R5M31-4-MKD	31/9	L200-2WD	6G72
	R5M31-4-MJD	30/9	L200-2WD	6G72
	V5M31-5-YG	27/9	PAJERO/MONTERO	6G74
	V5M31-5-YI	29/9	PAJERO/MONTERO	6G74
	V5M31-5-SJ	30/9	PAJERO/MONTERO	4M40

TRANSMISSION MODEL TABLE - MODEL 2001

	Transmission model	Speedometer gear ratio	Vehicle model	Engine model
EUR	V5M31-6-XCL	-	PAJERO/MONTERO	4M41
	V5M31-6-XC	-	PAJERO/MONTERO	4M41
	V5M31-6-NFL	-	PAJERO/MONTERO	4D56 Turbocharger with charge air cooler
	V5M31-6-WDL	-	PAJERO/MONTERO	6G74 GDI
	V5M31-6-WD	-	PAJERO/MONTERO	6G74 GDI
EXP	R5M31-B-MFDL	26/9	L200-2WD	6G72
	R5M31-B-MHDL	28/9	L200-2WD	6G72
	V5M31-B-SIG2	29/9	L200-4WD	4M40
	V5M31-B-SIG3	29/9	L200-4WD	4M40
	V5M31-6-SFCL	-	PAJERO/MONTERO	4M40
	V5M31-6-SFC	-	PAJERO/MONTERO	4M40
	V5M31-6-SFBL	-	PAJERO/MONTERO	4M40
	V5M31-6-SFB	-	PAJERO/MONTERO	4M40
	V5M31-6-XCB	-	PAJERO/MONTERO	4M41
	V5M31-6-MEL	-	PAJERO/MONTERO	6G72
	V5M31-6-ME	-	PAJERO/MONTERO	6G72
	V5M31-6-YDCL	-	PAJERO/MONTERO	6G74
	V5M31-6-YDBL	-	PAJERO/MONTERO	6G74
	V5M31-6-YDB	-	PAJERO/MONTERO	6G74
AUS	R5M31-4-MKD	31/9	L200-2WD	6G72
	R5M31-4-MJD	30/9	L200-2WD	6G72
	V5M31-6-SFT	-	PAJERO/MONTERO	4M40
	V5M31-6-SF	-	PAJERO/MONTERO	4M40
	V5M31-6-YDT	-	PAJERO/MONTERO	6G74
	V5M31-6-YD	-	PAJERO/MONTERO	6G74

GENERAL SPECIFICATIONS

Items	V5M31-5-Y, V5M31-6-M	V5M31-6-N	V5M31-5-S, V5M31-7, V5M31-6-S, X	V5M31-6-W, Y	R5M31
Transmission					
Gear ratio					
1st	3.952	3.952	3.952	4.234	3.952
2nd	2.238	2.238	2.238	2.238	2.238
3rd	1.398	1.398	1.398	1.398	1.398
4th	1.000	1.000	1.000	1.000	1.000
5th	0.819	0.760	0.761	0.819	0.761
Reverse	3.553	3.553	3.553	3.553	3.553
Transfer					
Gear ratio					
High	1.000	1.000	1.000	1.000	–
Low	1.900	1.900	1.900	1.900	–

SERVICE SPECIFICATIONS

mm (in.)

	Standard	Limit
Transmission		
Main drive pinion bearing end play	0 – 0.06 (0 – 0.0024)	
Main drive pinion end play	0 – 0.1 (0 – 0.004)	
3rd-4th speed synchronizer hub end play	0 – 0.08 (0 – 0.0031)	
Countershaft cluster gear bearing end play	0 – 0.15 (0 – 0.0059)	
Clearance between outer synchronizer ring back surface and gear		0.3 (0.012)
Transfer <V5M31>		
Input gear bearing end play	0 – 0.06 (0 – 0.0024)	
H-L clutch hub end play	0 – 0.08 (0 – 0.0031)	
Differential lock hub or clutch hub end play	0 – 0.08 (0 – 0.0031)	
2-4WD synchronizer hub or clutch hub end play	0 – 0.08 (0 – 0.0031)	
Countershaft gear bearing end play	0 – 0.08 (0 – 0.0031)	
Countershaft gear end play	0 – 0.15 (0 – 0.0059)	
Rear output shaft bearing end play	0 – 0.08 (0 – 0.0031)	
Center differential end play <Super select 4WD>	0 – 0.1 (0 – 0.004)	
Clearance between outer synchronizer ring and drive sprocket		0.3 (0.012)
Rear output shaft bearing preload <Super select 4WD II>	0.12 – 0.24 (0.005 – 0.009)	
Clearance between rear output shaft bearing and rear cover <Super select 4WD II>	0 – 0.12 (0 – 0.005)	

Intentionally blank

TORQUE SPECIFICATIONS

	Torque		
	Nm	kgm	ft.lbs.
Transmission			
Clutch housing — Transmission case mounting bolt	36	3.6	26
Transmission case — Intermediate plate mounting bolt	36	3.6	26
<V5M31>			
Intermediate plate — Transfer case adapter mounting bolt	36	3.6	26
<V5M31>			
Transfer case adapter — Transfer case plate mounting bolt	36	3.6	26
<V5M31>			
Transfer case plate — Transfer case mounting bolt	36	3.6	26
<V5M31>			
Main shaft lock nut	260	26	188
Countershaft cluster gear lock nut	260	26	188
Rear bearing retainer mounting bolt	19	1.9	14
5th speed gear shift lever mounting bolt	19	1.9	14
Neutral return plunger plug <V5M31>	36	3.6	26
Upper cover mounting bolt <V5M31>	19	1.9	14
Stopper bracket mounting nut <V5M31-6>	19	1.9	14
Poppet plug	36	3.6	26
Backlight switch	30	3.0	22
Extension housing – Transmission case mounting bolt	35	3.5	25
<R5M31>			
Control housing mounting bolt <R5M31>	19	1.9	14
Extension housing cover mounting bolt <R5M31>	19	1.9	14
Speedometer gear mounting bolt <R5M31>	14	1.4	10
Shift lever screw <R5M31>	9	0.9	6.5
Select lever nut <R5M31>	19	1.9	14
Cover mounting bolt <R5M31>	4	0.4	2.9
Plunger <R5M31>	48	4.8	35
Stopper bracket mounting bolt <R5M31>			
Reamer bolt	18	1.8	13
Flange bolt	3.9	0.39	2.8
Transfer <V5M31>			
Transfer case plate — Transfer case mounting bolt	36	3.6	26
Transfer case — Chain cover mounting bolt	36	3.6	26
Chain cover — Rear cover mounting bolt	36	3.6	26
Front bearing retainer mounting bolt	19	1.9	14
Rear bearing retainer mounting bolt <Super select type>	19	1.9	14
Oil pool cover mounting bolt <Super select 4WD>	9.0	0.9	6.5
Side cover mounting bolt	9.0	0.9	6.5
<Part time 4WD and Super select 4WD>			
Speedometer driven gear sleeve clamp mounting bolt	19	1.9	14
<Part time 4WD and Super select 4WD>			
Detection switch <Part time 4WD and Super select 4WD>	36	3.6	26
Plug <Part time 4WD and Super select 4WD>	36	3.6	26
Poppet plug <Part time 4WD and Super select 4WD>	36	3.6	26
Center differential case mounting bolt <Super select 4WD>	65	6.5	47
Plunger boss mounting bolt	19	1.9	14
<Part time 4WD and Super select 4WD>			

	Torque		
	Nm	kgm	ft.lbs.
Rear output shaft lock nut <Part time 4WD and Super select 4WD>	115	11.5	83
H-L shift rail plug <Part time 4WD and Super select 4WD>	33	3.3	24
Dynamic damper mounting bolt <V5M31-6>	36	3.6	26
Under guard mounting bolt <EXP>	36	3.6	26
Shift actuator mounting bolt <Super select 4WD II>	22	2.2	16
Front output sensor mounting bolt <Super select 4WD II>	11	1.1	8
Rear output sensor mounting bolt <Super select 4WD II>	11	1.1	8
Vehicle speed sensor mounting bolt <Super select 4WD II>	11	1.1	8
Transfer case cover bolt <Super select 4WD II>	19	1.9	14
2WD switch <Super select 4WD II>	36	3.6	26
2WD-4WD switch <Super select 4WD II>	36	3.6	26
4H switch <Super select 4WD II>	36	3.6	26
4LLC switch <Super select 4WD II>	36	3.6	26
Center differential lock switch <Super select 4WD II>	36	3.6	26

Intentionally blank

SEALANTS

	Specified sealant
Transmission	
Clutch housing — Transmission case mating surface	Mitsubishi genuine sealant Part No. MD997740 or equivalent
Transmission case — Intermediate plate mating surface	Mitsubishi genuine sealant Part No. MD997740 or equivalent
Intermediate plate — Transfer case adapter mating surface	Mitsubishi genuine sealant Part No. MD997740 or equivalent
<V5M31>	
Transfer case adapter — Transfer case plate mating surface	Mitsubishi genuine sealant Part No. MD997740 or equivalent
<V5M31>	
Upper cover — Transfer case adapter mating surface	Mitsubishi genuine sealant Part No. MD997740 or equivalent
<V5M31>	
Air breather	Mitsubishi genuine sealant Part No. MD997740 or equivalent
Clutch housing – Transmission case mating surface	Mitsubishi genuine sealant Part No. MD997740 or equivalent
<R5M31>	
Transmission case – Intermediate plate mating surface	Mitsubishi genuine sealant Part No. MD997740 or equivalent
<R5M31>	
Intermediate plate – Extension housing mating surface	Mitsubishi genuine sealant Part No. MD997740 or equivalent
<R5M31>	
Extension housing – Extension housing cover mating surface	Mitsubishi genuine sealant Part No. MD997740 or equivalent
<R5M31>	
Extension housing – Control housing mating surface	Mitsubishi genuine sealant Part No. MD997740 or equivalent
<R5M31>	
Control shaft cap <R5M31>	Mitsubishi genuine sealant Part No. MD997740 or equivalent
Rear bearing retainer mounting bolt	3M STUD Locking No. 4170 or equivalent
Resistance spring plug <V5M31>	3M ATD Part No. 8660 or equivalent
Poppet plug	3M ATD Part No. 8660 or equivalent
Neutral return plunger plug <V5M31>	3M ATD Part No. 8660 or equivalent
Plunger <R5M31>	3M ATD Part No.8660 or equivalent
Transfer <V5M31>	
Transfer case plate — Transfer case mating surface	Mitsubishi genuine sealant Part No. MD997740 or equivalent
Transfer case — Chain cover mating surface	Mitsubishi genuine sealant Part No. MD997740 or equivalent
Chain cover — Rear cover mating surface	Mitsubishi genuine sealant Part No. MD997740 or equivalent
Front bearing retainer mounting bolt	3M STUD Locking No. 4170 or equivalent
Rear bearing retainer mounting bolt <Super select type>	3M STUD Locking No. 4170 or equivalent
Poppet plug <Part time 4WD and super select 4WD>	3M ATD Part No. 8660 or equivalent
Plug <Part time 4WD and super select 4WD>	3M ATD Part No. 8660 or equivalent

LUBRICANTS

	Specified grease
Each oil seal, lip area	Mitsubishi genuine grease Part No. 0101011 or equivalent
Return spring plunger, friction area <V5M31>	Mitsubishi genuine grease Part No. 0101011 or equivalent
Shift lever – Control finger, friction <R5M31>	Mitsubishi genuine grease Part No. 0101011 or equivalent
Synchronizer cone, whole surface	Hypoid gear oil API GL-4 SAE 75W-85W or 80W

ADJUSTMENT SNAP RINGS AND SPACERS

Part name	Thickness mm (in.)	Identification symbol	Part No.
Transmission			
Snap ring	2.32 (0.0913)	Blue	MB919165
	(For adjustment of main drive gear bearing end play)	—	MB919166
	2.42 (0.0952)	Brown	MB919167
	2.47 (0.0972)	White	MB919168
Spacer	0.68 (0.0268)	—	MB919169
	(For adjustment of main drive gear end play)	Red	MB919170
	0.77 (0.0303)	Yellow	MB919171
	0.86 (0.0339)	Orange	MB919172
	0.95 (0.0374)	White	MB919173
Snap ring	2.18 (0.0858)	Blue	MB919184
	(For adjustment of 3rd-4th speed synchronizer hub end play)	—	MB919185
	2.25 (0.0886)	Brown	MB919186
	2.32 (0.0913)	White	MB919187
Snap ring	1.48 (0.0583)	Blue	MB919176
	(For adjustment of countershaft cluster gear end play)	—	MB919177
Transfer <V5M31>			
Snap ring	2.30 (0.0906)	—	MD704199
	(For adjustment of input gear bearing end play)	Red	MD704200
	2.35 (0.0925)	White	MD704201
	2.40 (0.0945)	Blue	MD704202
	2.45 (0.0965)	Green	MD704203
Snap ring	2.18 (0.0858)	Blue	MR110983
	<For snap ring groove bottom diameter: 42.9 mm (1.689 in.)>	—	MR110984
	(For adjustment of H-L clutch hub end play)	Brown	MR110985
	2.32 (0.0913)	White	MR110986
Snap ring	2.18 (0.0858)	—	MR410928
	<For snap ring groove bottom diameter: 39.7 mm (1.563 in.)>	—	MR410929
	(For adjustment of H-L clutch hub end play)	—	MR410930
	2.32 (0.0913)	—	MR410931
	2.39 (0.0941)	—	MR410931

Part name	Thickness mm (in.)	Identification symbol	Part No.
Snap ring (For adjustment of differential lock hub end play)	2.56 (0.1008)	—	MD738386
	2.63 (0.1035)	Red	MD738387
	2.70 (0.1063)	White	MD738388
	2.77 (0.1091)	Blue	MD738389
	2.84 (0.1118)	Yellow	MD738390
	2.91 (0.1146)	Green	MD738391
	2.98 (0.1173)	Brown	MD738392
Snap ring (For adjustment of 2-4WD synchronizer hub end play)	2.56 (0.1008)	—	MD738393
	2.63 (0.1035)	Red	MD738394
	2.70 (0.1063)	White	MD738395
	2.77 (0.1091)	Blue	MD738396
	2.84 (0.1118)	Yellow	MD738397
Snap ring (For adjustment of transfer counter gear bearing end play)	1.48 (0.0583)	Blue	MB919176
	1.62 (0.0638)	—	MB919177
Spacer (For adjustment of transfer counter gear end play)	1.77 (0.0697)	—	MB896728
	1.91 (0.0752)	Blue	MB896729
	2.05 (0.0807)	Brown	MB896730
	2.19 (0.0862)	White	MB896731
	2.33 (0.0917)	Red	MB896732
Snap ring (For adjustment of rear output shaft bearing end play)	2.26 (0.0890)	—	MD734311
	2.33 (0.0917)	Red	MD734312
	2.40 (0.0945)	White	MD734313
	2.47 (0.0972)	Blue	MD734314
Spacer <Super select 4WD> (For adjustment of rear center differential end play)	0.84 (0.0331)	84	MD734326
	0.93 (0.0366)	93	MD734327
	1.02 (0.0402)	02	MD734328
	1.11 (0.0437)	11	MD734329
	1.20 (0.0472)	20	MD734330
	1.29 (0.0508)	29	MD734331
	1.38 (0.0543)	38	MD734332
	1.47 (0.0579)	47	MD734333
	1.56 (0.0614)	56	MD734334
	1.65 (0.0650)	65	MD734335
	1.74 (0.0685)	74	MD734336
	1.83 (0.0720)	83	MD734337
	1.92 (0.0756)	92	MD734338
2.01 (0.0791)	01	MD734339	
Snap ring <Super select 4WD II> (For adjustment of annulus gear snap ring end play)	1.90 (0.0748)	—	MR305024
	1.94 (0.0764)	—	MR305025
	1.98 (0.0780)	—	MR305026
	2.02 (0.0795)	—	MR305027
	2.06 (0.0787)	—	MR305028
	2.10 (0.0827)	—	MR305029

Part name	Thickness mm (in.)	Identification symbol	Part No.
Snap ring <Super select 4WD II> (For adjustment of rear output shaft bearing preload)	1.57 (0.0618)	—	MR486340
	1.63 (0.0642)	—	MR486341
	1.69 (0.0665)	—	MR486342
	1.75 (0.0689)	—	MR486343
	1.81 (0.0713)	—	MR486344
	1.87 (0.0736)	—	MR486345
	1.93 (0.0760)	—	MR486346
	1.99 (0.0783)	—	MR486347
	2.05 (0.0807)	—	MR477935
	2.11 (0.0831)	—	MR477936
	2.17 (0.0854)	—	MR477937
	2.23 (0.0878)	—	MR477938
	2.29 (0.0902)	—	MR477939
	2.35 (0.0925)	—	MR477940
	2.41 (0.0949)	—	MR477941
	2.47 (0.0972)	—	MR477942
	2.53 (0.0996)	—	MR477943
	2.59 (0.1020)	—	MR477944
	2.65 (0.1043)	—	MR477945
2.71 (0.1067)	—	MR477946	
Spacer <Super select 4WD II> (For adjustment of clearance between rear output shaft bearing and rear cover)	2.57 (0.1012)	—	MR477950
	2.63 (0.1035)	—	MR477951
	2.69 (0.1059)	—	MR477952
	2.75 (0.1083)	—	MR477953
	2.81 (0.1106)	—	MR477954
	2.87 (0.1130)	—	MR477955
	2.93 (0.1154)	—	MR477956
	2.99 (0.1177)	—	MR477957
	3.05 (0.1201)	—	MR477958
	3.11 (0.1224)	—	MR477959
	3.17 (0.1248)	—	MR477960
	3.23 (0.1272)	—	MR477961
	3.29 (0.1295)	—	MR477962
	3.35 (0.1319)	—	MR477963
	3.41 (0.1343)	—	MR477964
	3.47 (0.1366)	—	MR477965
	3.53 (0.1390)	—	MR477966
	3.59 (0.1413)	—	MR477967
	3.65 (0.1437)	—	MR477968
3.71 (0.1461)	—	MR486348	
3.77 (0.1484)	—	MR486349	
3.83 (0.1508)	—	MR486350	
3.89 (0.1531)	—	MR486351	
3.95 (0.1555)	—	MR486352	

2. SPECIAL TOOLS**TRANSMISSION**

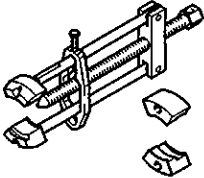
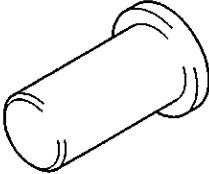
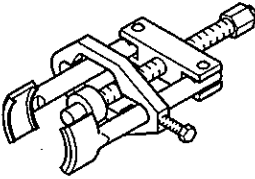
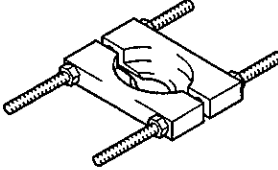
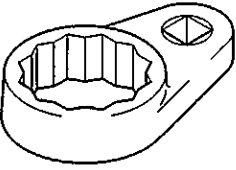
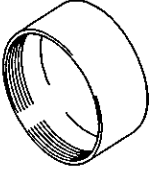
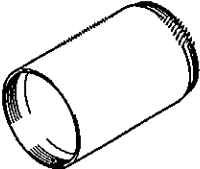
Tool	Number	Name	Use
	MD998020	Bearing puller	Removal of reverse gear bearing sleeve
	MD998304	Oil seal installer	Installation of clutch housing oil seal
	MD998348	Bearing puller	Removal of countershaft cluster gear bearing, main shaft rear bearing
	MD998801	Bearing remover	Removal of main drive pinion bearing, countershaft cluster bearing and sleeve, 3-4 speed synchronizer hub
	MD998809	Lock nut wrench	Removal and installation of countershaft cluster gear lock nut
	MD998812	Installer cap	Use together with the installer and installer adapter
	MD998813	Installer (100)	Use together with the installer adapter and installer cap

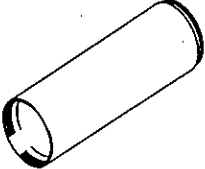
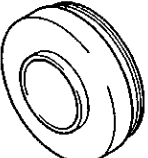
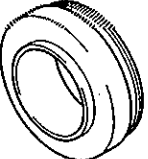
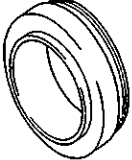
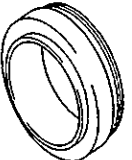
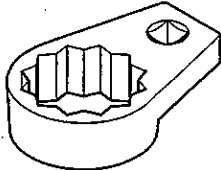
Tool	Number	Name	Use
	MD998814	Installer (200)	Use together with the installer adapter and installer cap
	MD998817	Installer adapter (34)	Installation of countershaft cluster gear ball bearing
	MD998820	Installer adapter (42)	Installation of main shaft rear bearing, counter shaft cluster gear bearing, reverse gear bearing sleeve
	MD998823	Installer adapter (48)	Installation of main drive pinion bearing, 3-4 speed synchronizer hub
	MD998824	Installer adapter (50)	Installation of main shaft front bearing, 1-2 speed synchronizer hub
	MD998835	Lock nut wrench	Removal and installation of main shaft lock nut

TRANSFER <V5M31>

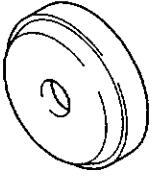
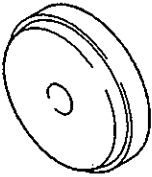
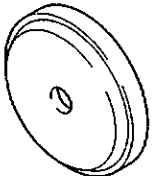
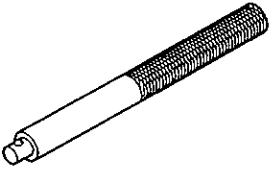
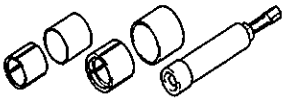
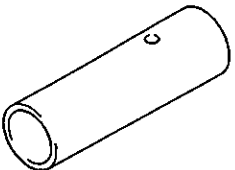
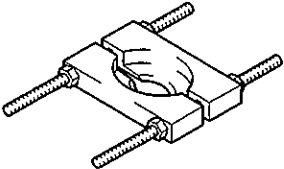
Tool	Number	Name	Use
	MB990929	Installer adapter	Installation of rear cover oil seal, front output oil seal
	MB990932	Installer adapter	Installation of front output oil seal
	MB990936	Installer adapter	Installation of input gear oil seal, rear cover oil seal
	MB990938	Installer bar	Use with installer adapter
	MD998192	Bearing puller	Installation of transfer drive shaft bearing
	MD998368	Bearing installer	Removal of counter gear bearing
	MD998801	Bearing remover	Removal of countershaft bearing, rear output bearing, front output bearing, H-L clutch hub, 2-4WD clutch hub

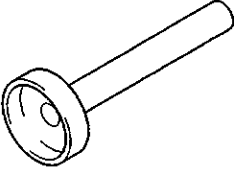
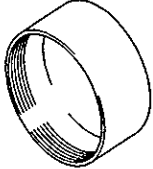
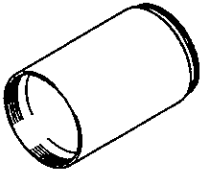
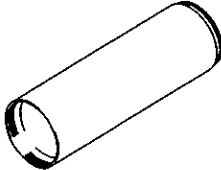
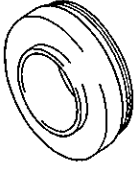
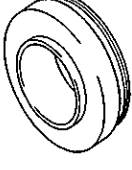
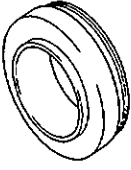
Tool	Number	Name	Use
	MD998803	Differential oil seal installer	Installation of input gear oil seal
	MD998812	Installer cap	Use together with the installer and installer adapter
	MD998813	Installer (100)	Used for installer cap and installer adapter
	MD998814	Installer (200)	Use together with the installer cap and installer adapter
	MD998818	Installer adapter (38)	Installation of counter gear bearing, front output shaft bearing
	MD998819	Installer adapter (40)	Installation of rear output shaft rear bearing
	MD998821	Installer adapter (44)	Installation of 2-4WD clutch hub, H-L clutch hub

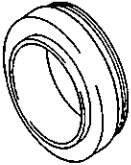
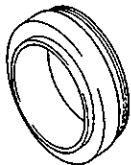
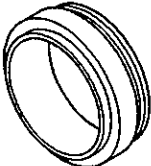
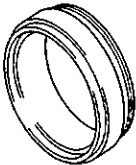
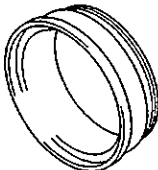
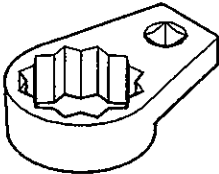
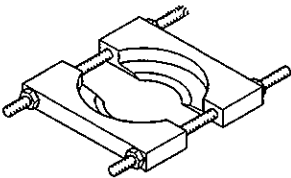
Tool	Number	Name	Use
	MD998823	Installer adapter (48)	Installation of rear output shaft bearing
	MD998824	Installer adapter (50)	Installation of input gear bearing, rear output bearing
	MD998826	Installer adapter (52)	Installation of input gear bearing
	MD998829	Installer adapter (60)	Installation of rear output shaft bearing
	MD998830	Installer adapter (66)	Installation of transfer drive shaft bearing
	MD998835	Lock nut wrench	Removal and installation of rear output shaft lock nut
	MD998917	Bearing remover	Removal of rear output shaft bearing, transfer drive shaft bearing

NOTES

3. TRANSMISSION DISASSEMBLY AND REASSEMBLY <V5M31-5>

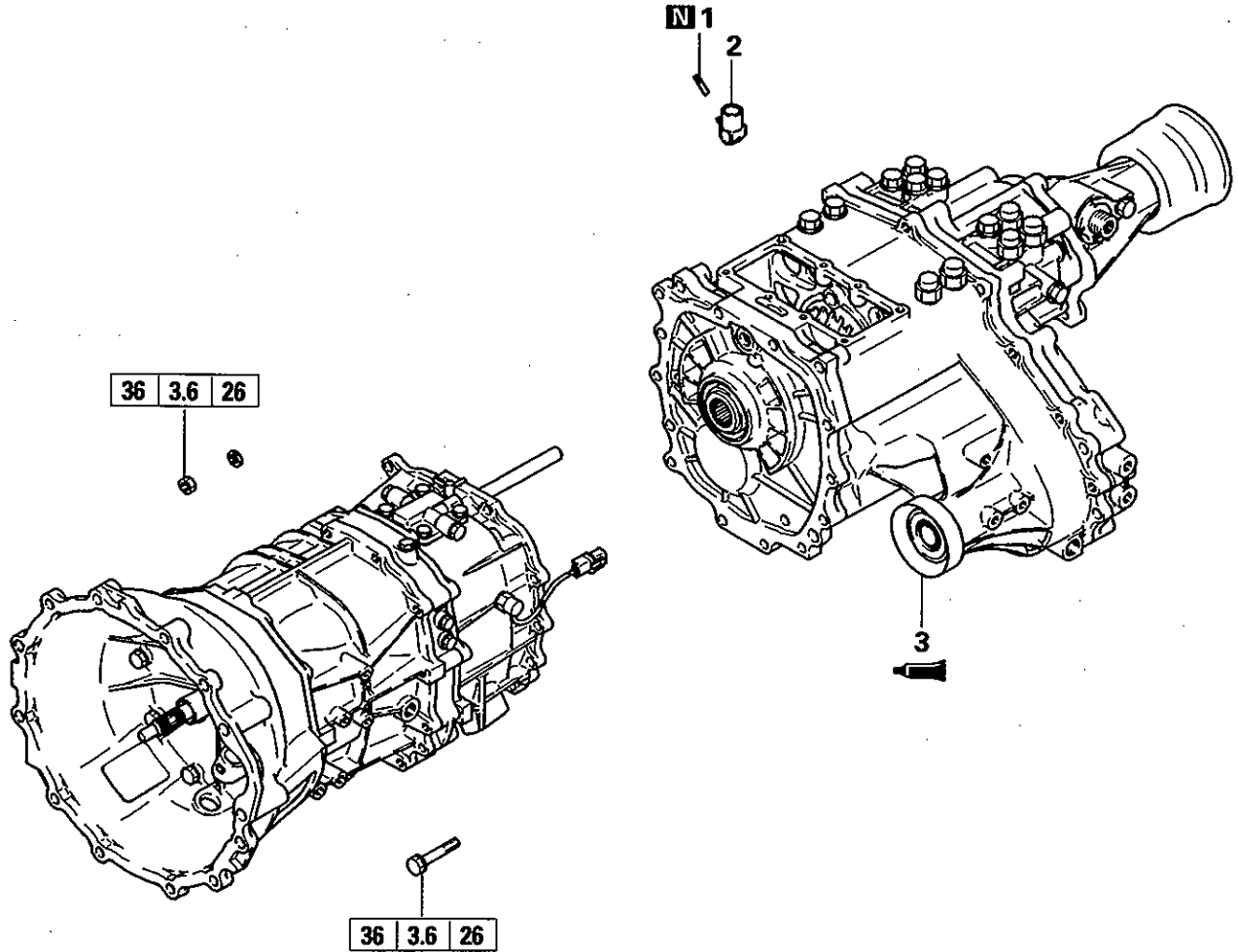

Disassembly steps

- ▶C▶ 1. Spring Pin
- 2. Change shifter
- ▶AD▶ 3. Transfer

 Apply gear oil to all moving parts before installation.

 Lubricate all internal parts with gear oil during reassembly.

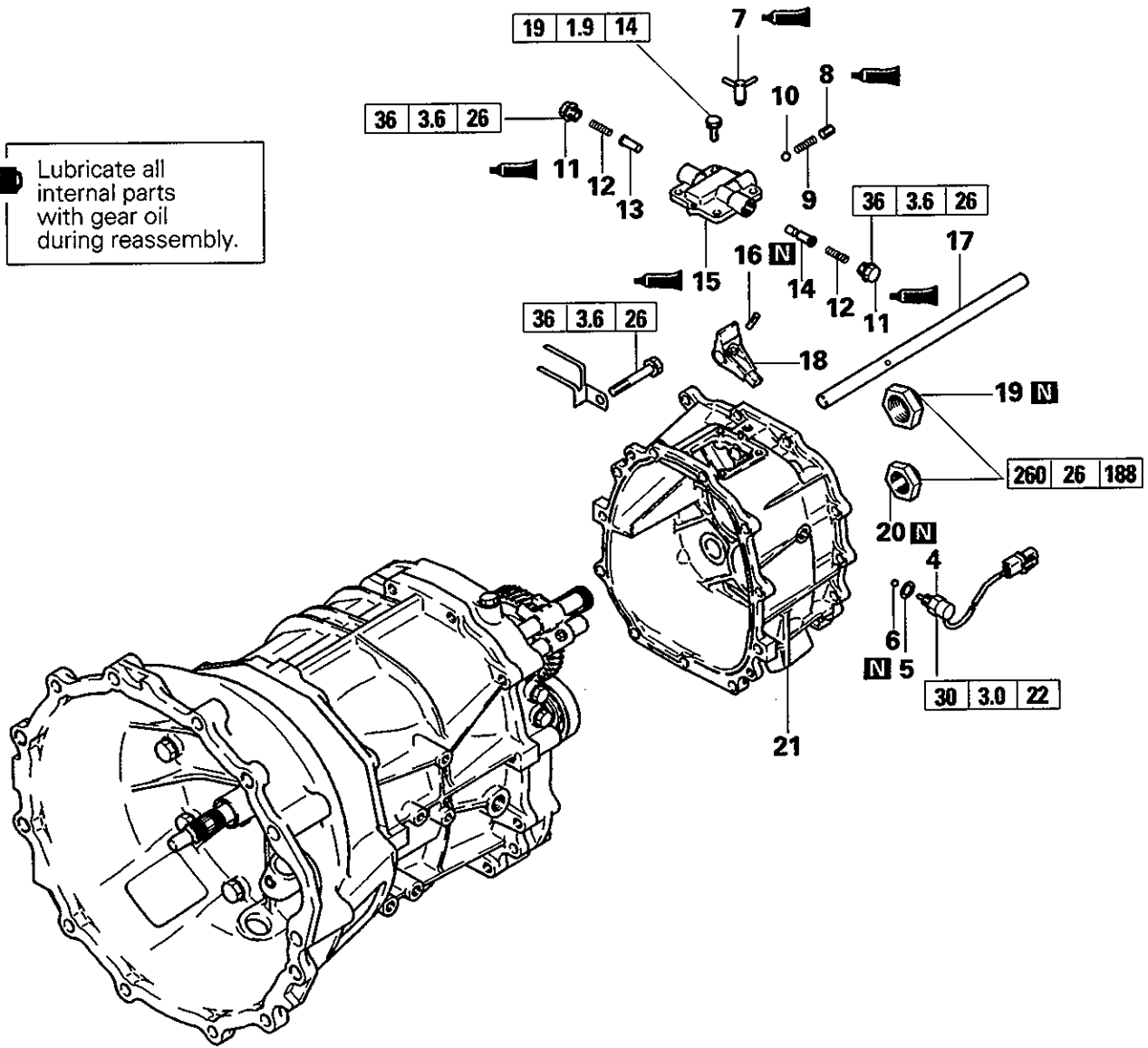

Disassembly steps

- | | |
|--------------------------------------|-------------------------------|
| 4. Backlight switch | 13. Neutral return plunger A |
| 5. Gasket | 14. Neutral return plunger B |
| 6. Steel ball | ▶Z▶ 15. Upper cover |
| ▶AC▶ 7. Air breather | ▶C▶ 16. Spring pin |
| ▶AB▶ 8. Resistance spring plug | 17. Control shaft |
| 9. Resistance spring | 18. Control finger |
| 10. Steel ball | ◁A▶ ▶Y▶ 19. Lock nut |
| ▶AA▶ 11. Neutral return plunger plug | ◁A▶ ▶Y▶ 20. Lock nut |
| 12. Neutral return spring | ▶X▶ 21. Transfer case adapter |



Lubricate all internal parts with gear oil during reassembly.

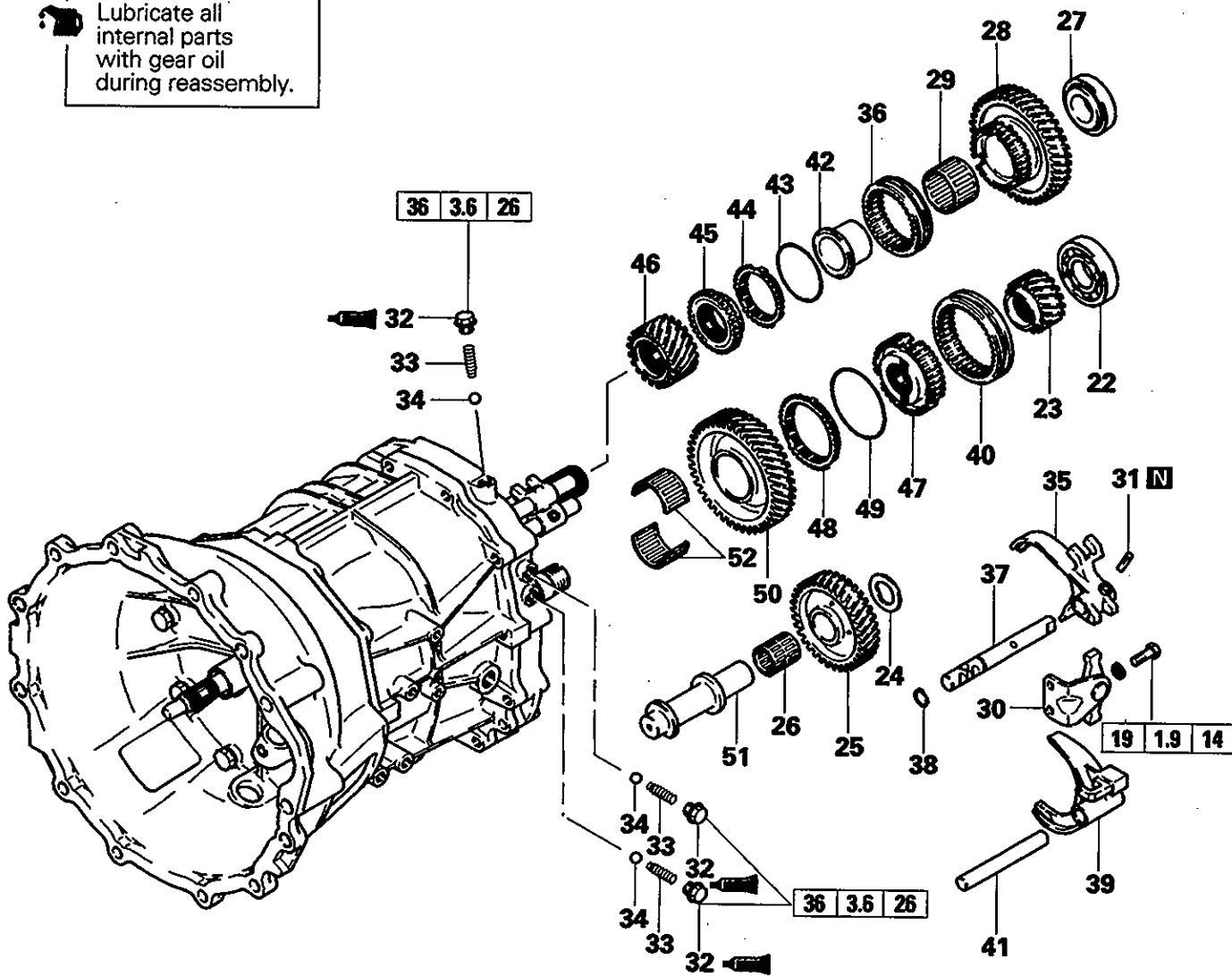

Disassembly steps

- ◁B▷ ▷W◁ 22. Ball bearing
- ▷V◁ 23. Counter reverse gear
- 24. Thrust washer
- ▷U◁ 25. Reverse idler gear
- 26. Needle bearing
- ◁C▷ ▷T◁ 27. Ball bearing
- ▷S◁ 28. Reverse gear
- 29. Needle bearing
- 30. 5th speed shift lever
- ▷C◁ 31. Spring pin
- ▷R◁ 32. Poppet plug
- ▷Q◁ 33. Poppet spring
- 34. Steel ball
- 35. Reverse shift fork
- ▷P◁ 36. Reverse synchronizer sleeve
- 37. Reverse shift rail

- 38. Snap ring
- 39. 5th speed shift fork
- ▷O◁ 40. 5th speed synchronizer sleeve
- 41. 5th speed shift rail
- ◁D▷ ▷N◁ 42. Reverse gear bearing sleeve
- 43. Synchronizer spring
- 44. Synchronizer ring
- ▷M◁ 45. Reverse brake gear
- ▷L◁ 46. Overtop gear
- ▷K◁ 47. 5th synchronizer hub
- 48. Synchronizer ring
- 49. Synchronizer spring
- ▷J◁ 50. Counter 5th speed gear
- 51. Reverse idler gear shaft
- 52. Needle bearing

Apply gear oil to all moving parts before installation.

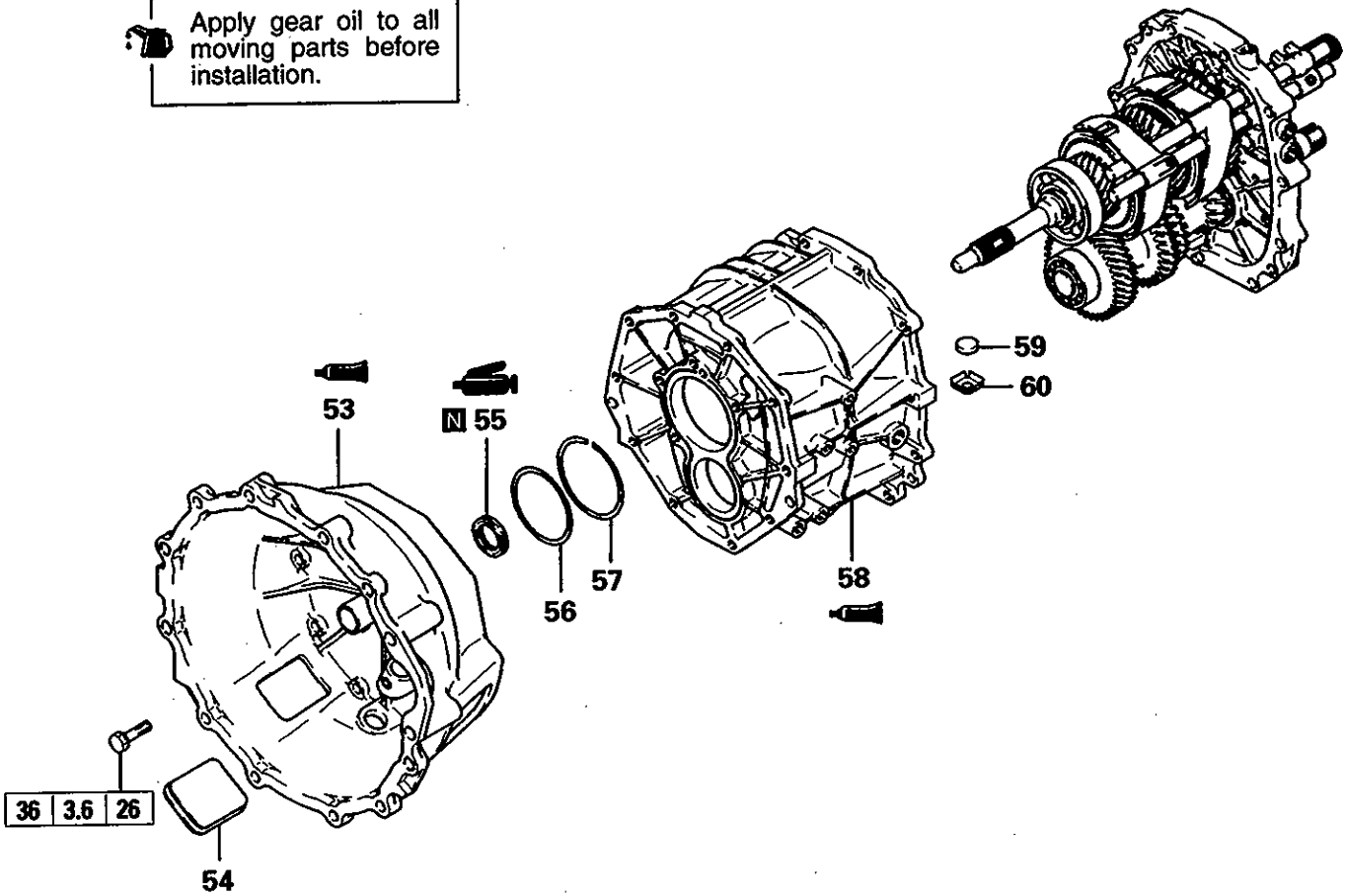

Disassembly steps

- ▶▶ 53. Clutch housing
- ▶▶ 54. Inspection hole cover
- ▶H 55. Oil seal
- ▶G 56. Spacer
- ▶▶ 57. Snap ring
- ▶F 58. Transmission case
- ▶D 59. Magnet
- ▶D 60. Magnet holder



Apply gear oil to all moving parts before installation.

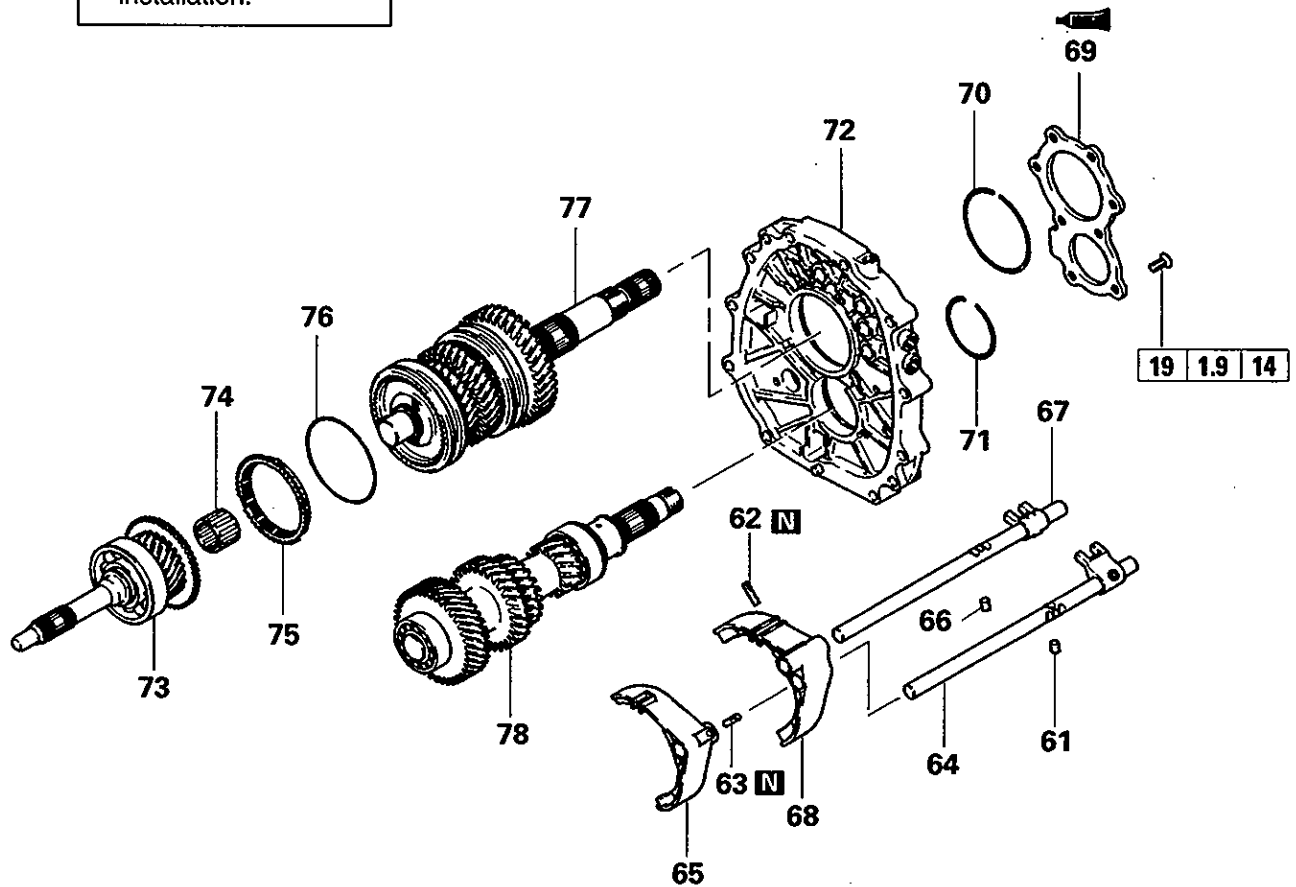

Disassembly steps

- 61. Interlock plunger
- ▶C▶ 62. Spring pin
- ▶C▶ 63. Spring pin
- 64. 3rd-4th speed shift rail
- 65. 3rd-4th speed shift fork
- 66. Interlock plunger
- 67. 1st-2nd speed shift rail
- 68. 1st-2nd speed shift fork
- ▶B▶ 69. Rear bearing retainer
- ◁E▷ 70. Snap ring
- ◁E▷ 71. Snap ring
- ◁F▷ ▶A▶ 72. Intermediate plate
- 73. Main drive pinion
- 74. Needle bearing
- 75. Synchronizer ring
- 76. Synchronizer spring
- 77. Main shaft
- 78. Countershaft cluster gear

DISASSEMBLY AND REASSEMBLY

<R5M31-7 (Column shift type)>

Apply gear oil to all moving parts before installation.

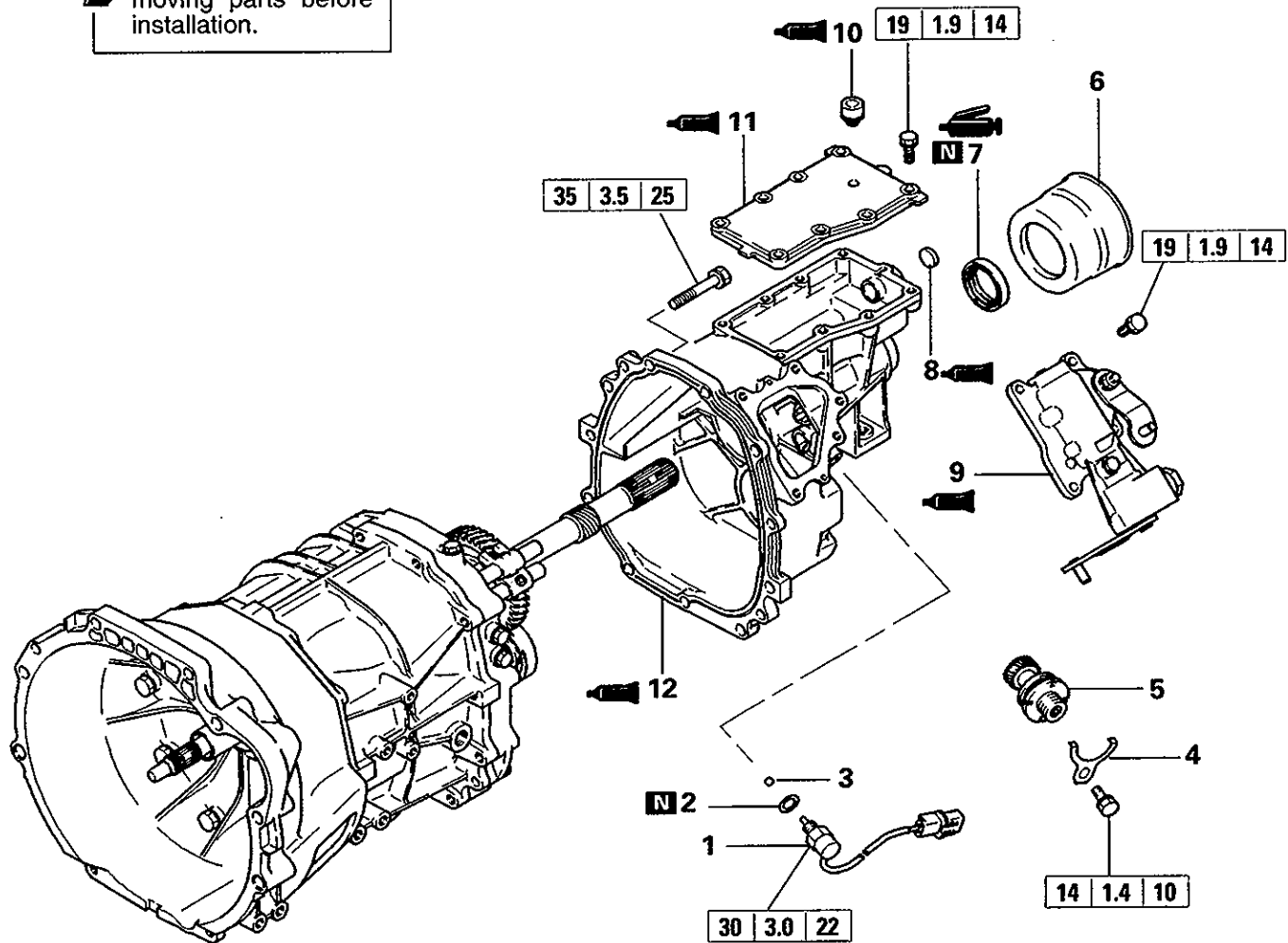

Disassembly steps

1. Backlight switch
2. Gasket
3. Steel ball
4. Sleeve clamp
- ◆AK◆ 5. Speedometer gear
6. Dust seal guard
- ◆AJ◆ 7. Oil seal
- ◆AI◆ 8. Control shaft cap
- ◆AH◆ 9. Control housing
- ◆AG◆ 10. Air breather
- ◆AF◆ 11. Extension housing cover
- ◆AE◆ 12. Extension housing



Lubricate all internal parts with gear oil during reassembly.

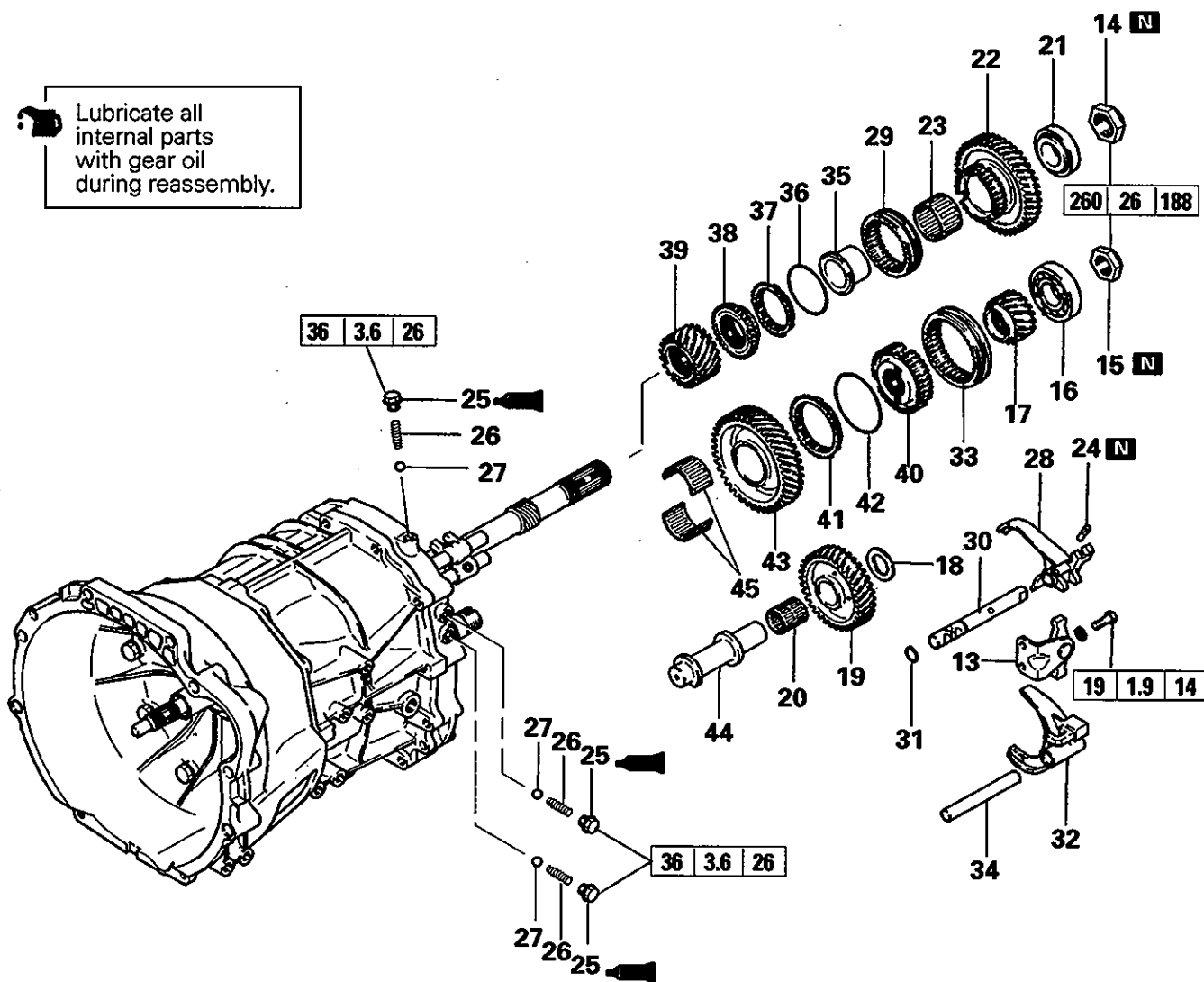

Disassembly steps

- 13. 5th speed shift lever
- ◊A◊ ▶Y◊ 14. Lock nut
- ◊A◊ ▶Y◊ 15. Lock nut
- ◊B◊ ▶W◊ 16. Ball bearing
- ▶V◊ 17. Counter reverse gear
- ▶U◊ 18. Thrust washer
- ▶U◊ 19. Reverse idler gear
- ▶U◊ 20. Needle bearing
- ◊C◊ ▶T◊ 21. Ball bearing
- ▶S◊ 22. Reverse gear
- ▶S◊ 23. Needle bearing
- ▶C◊ 24. Spring pin
- ▶R◊ 25. Poppet plug
- ▶Q◊ 26. Poppet spring
- ▶Q◊ 27. Steel ball
- ▶P◊ 28. Reverse shift fork
- ▶P◊ 29. Reverse synchronizer sleeve

- 30. Reverse shift rail
- 31. Snap ring
- 32. 5th speed shift fork
- ▶O◊ 33. 5th speed synchronizer sleeve
- ◊D◊ ▶N◊ 34. 5th speed shift rail
- ▶O◊ 35. Reverse gear bearing sleeve
- ▶O◊ 36. Synchronizer spring
- ▶O◊ 37. Synchronizer ring
- ▶M◊ 38. Reverse brake gear
- ▶L◊ 39. Overtop gear
- ▶K◊ 40. 5th speed synchronizer hub
- ▶J◊ 41. Synchronizer ring
- ▶J◊ 42. Synchronizer spring
- ▶J◊ 43. Counter 5th speed gear
- ▶J◊ 44. Reverse idler gear shaft
- ▶J◊ 45. Needle bearing

Apply gear oil to all moving parts before installation.

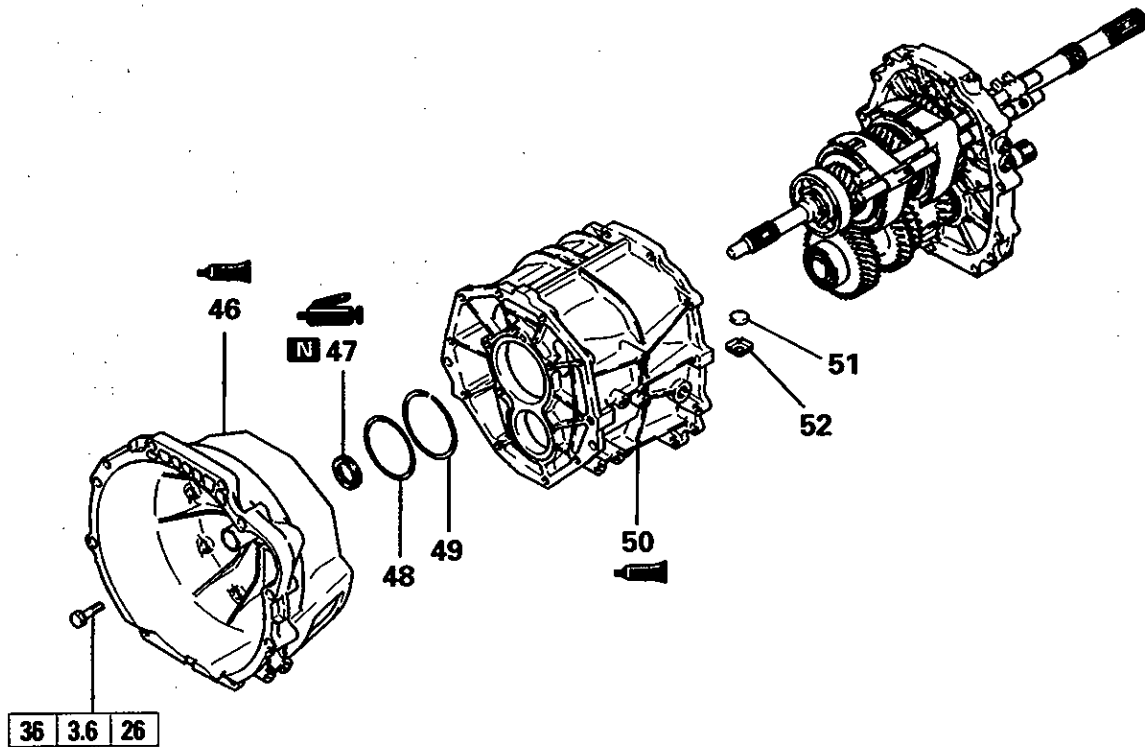

Disassembly steps

- ◆◆ 46. Clutch housing
- ◆H◆ 47. Oil seal
- ◆G◆ 48. Spacer
- 49. Snap ring
- ◆F◆ 50. Transmission case.
- ◆D◆ 51. Magnet
- ◆D◆ 52. Magnet holder

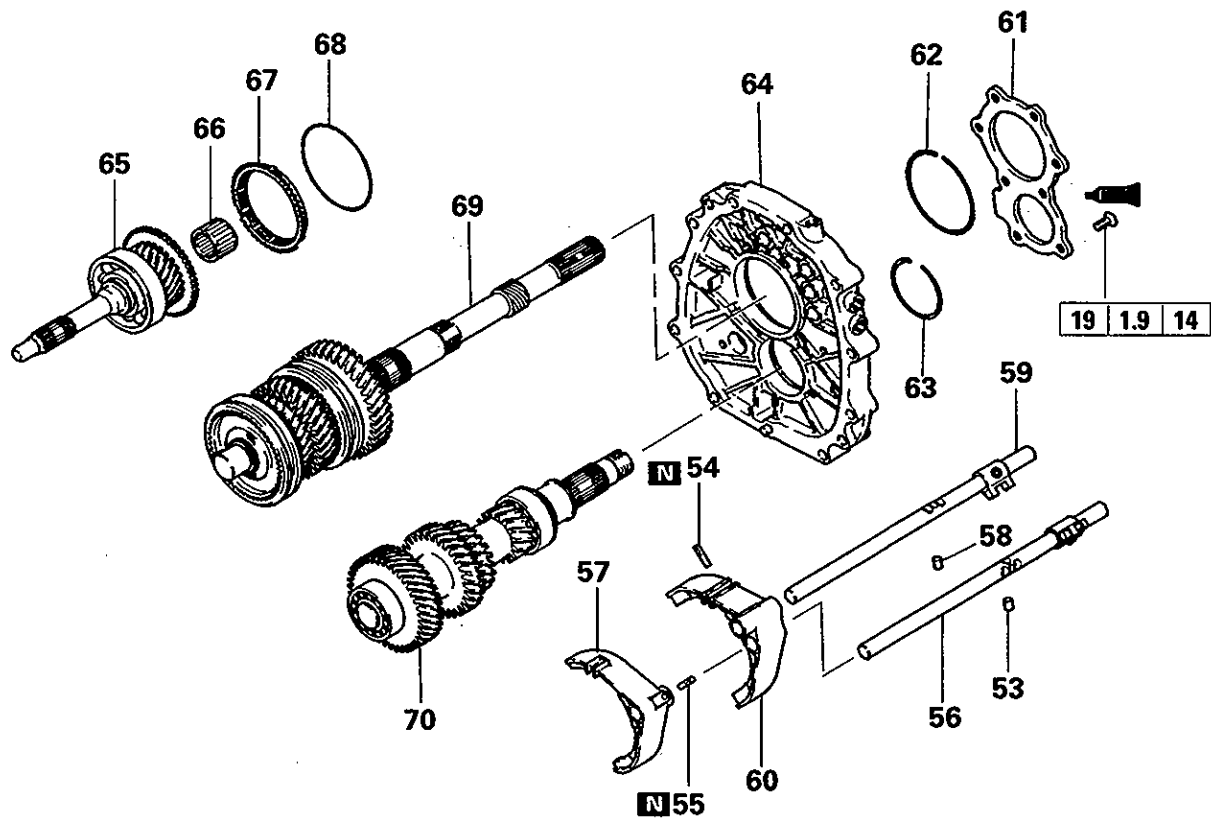

 Apply gear oil to all moving parts before installation.

Disassembly steps

- 53. Interlock plunger
- ▶C▶ 54. Spring pin
- ▶C▶ 55. Spring pin
- 56. 3rd-4th speed shift rail
- 57. 3rd-4th speed shift fork
- 58. Interlock plunger
- 59. 1st-2nd speed shift rail
- 60. 1st-2nd speed shift fork
- ▶B▶ 61. Rear bearing retainer
- ◊E◊ 62. Snap ring
- ◊E◊ 63. Snap ring
- ◊F◊ ▶A▶ 64. Intermediate plate
- 65. Main drive pinion
- 66. Needle bearing
- 67. Synchronizer ring
- 68. Synchronizer spring
- 69. Main shaft
- 70. Countershaft cluster gear

<R5M31-7 (Floor shift type)>

Apply gear oil to all moving parts before installation.

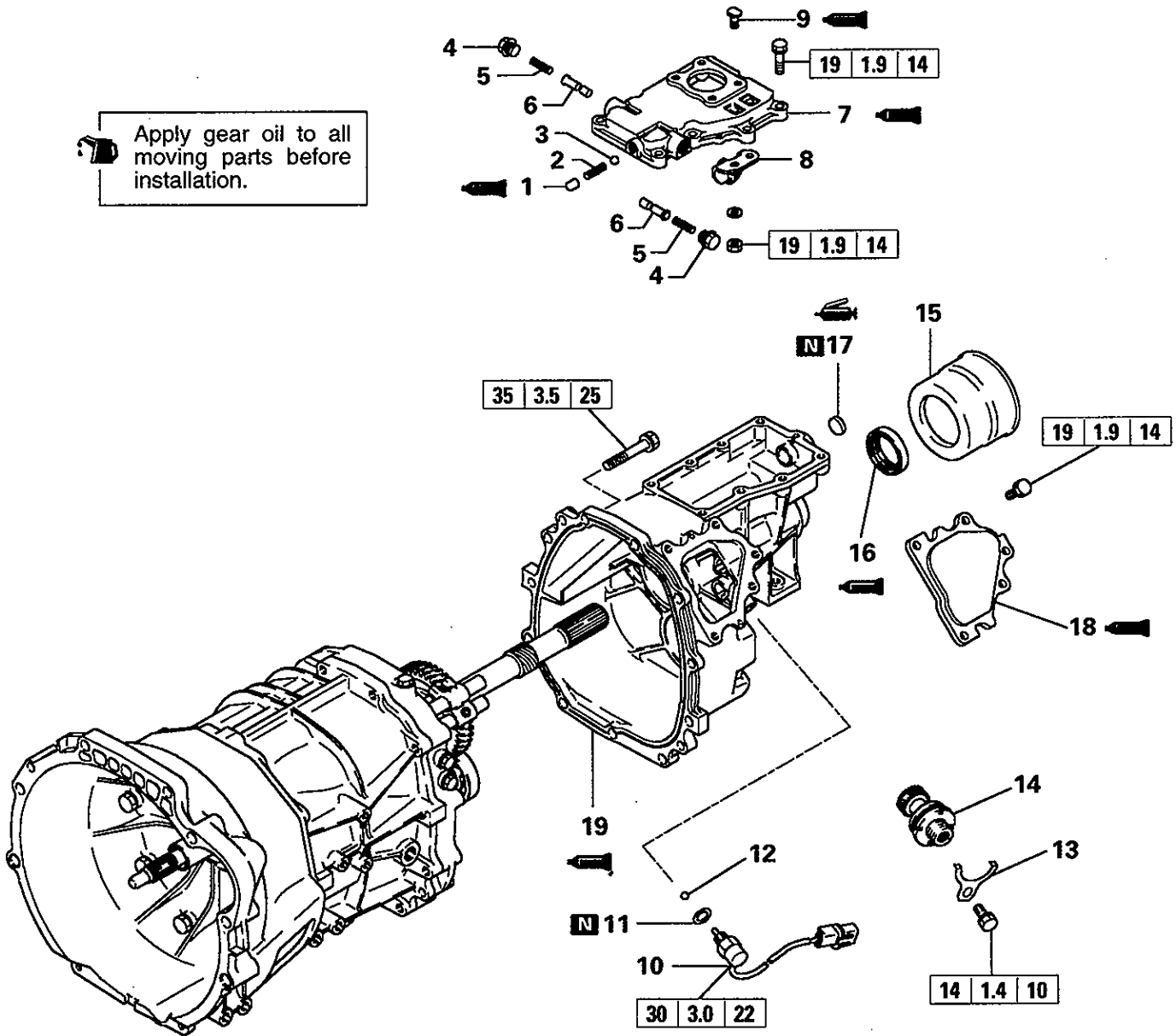

Disassembly steps

- | | |
|--|---|
| <p>▶AB▶ 1. Resistance spring plug
▶AA▶ 4. Neutral return plunger plug
▶AM▶ 7. Control housing
▶AL▶ 9. Special bolt</p> | <p>2. Resistance spring
3. Steel ball
5. Neutral return spring
6. Neutral return plunger
8. Stopper bracket
10. Backlight switch
11. Gasket
12. Steel ball
13. Sleeve clamp
14. Speedometer gear
15. Dust seal guard
16. Oil seal
17. Control shaft cap
18. Cover
19. Extension housing</p> |
|--|---|

Apply gear oil to all moving parts before installation.

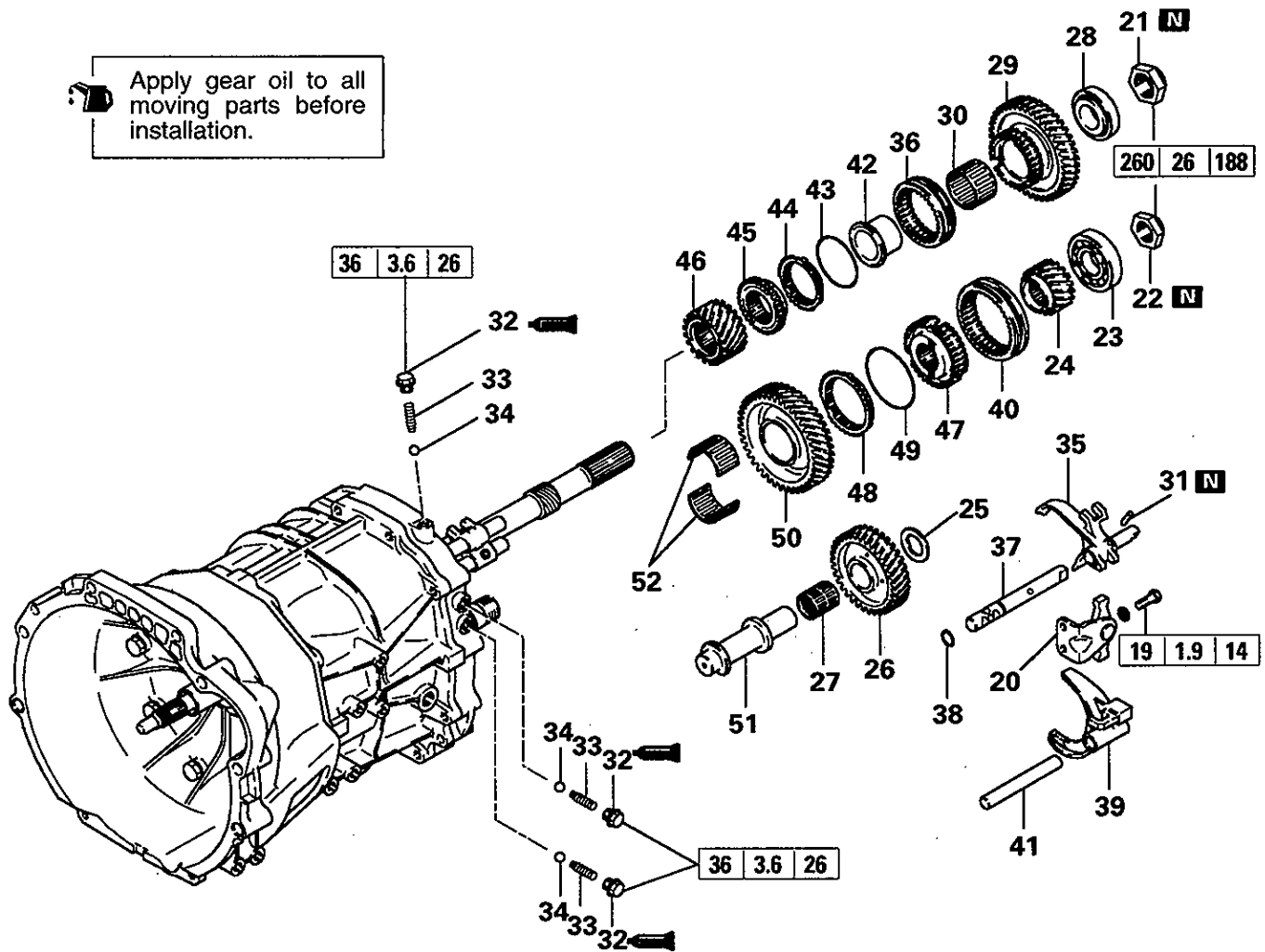

Disassembly steps

- 20. 5th speed shift lever
- ◊A◊ ▶Y◊ 21. Lock nut
- ◊A◊ ▶Y◊ 22. Lock nut
- ◊B◊ ▶W◊ 23. Ball bearing
- ▶V◊ 24. Counter reverse gear
- ▶U◊ 25. Thrust washer
- ▶U◊ 26. Reverse idler gear
- 27. Needle bearing
- ◊C◊ ▶T◊ 28. Ball bearing
- ▶S◊ 29. Reverse gear
- ▶C◊ 30. Needle bearing
- ▶C◊ 31. Spring pin
- ▶R◊ 32. Poppet plug
- ▶Q◊ 33. Poppet spring
- 34. Steel ball
- 35. Reverse shift fork
- ▶P◊ 36. Reverse synchronizer sleeve

- 37. Reverse shift rail
- 38. Snap ring
- 39. 5th speed shift fork
- ▶O◊ 40. 5th speed synchronizer sleeve
- ◊D◊ ▶N◊ 41. 5th speed shift rail
- ▶D◊ ▶N◊ 42. Reverse gear bearing sleeve
- 43. Synchronizer spring
- 44. Synchronizer ring
- ▶M◊ 45. Reverse brake gear
- ▶L◊ 46. Overtop gear
- ▶K◊ 47. 5th speed synchronizer hub
- 48. Synchronizer ring
- ▶J◊ 49. Synchronizer spring
- ▶J◊ 50. Counter 5th speed gear
- 51. Reverse idler gear shaft
- 52. Needle bearing

Apply gear oil to all moving parts before installation.

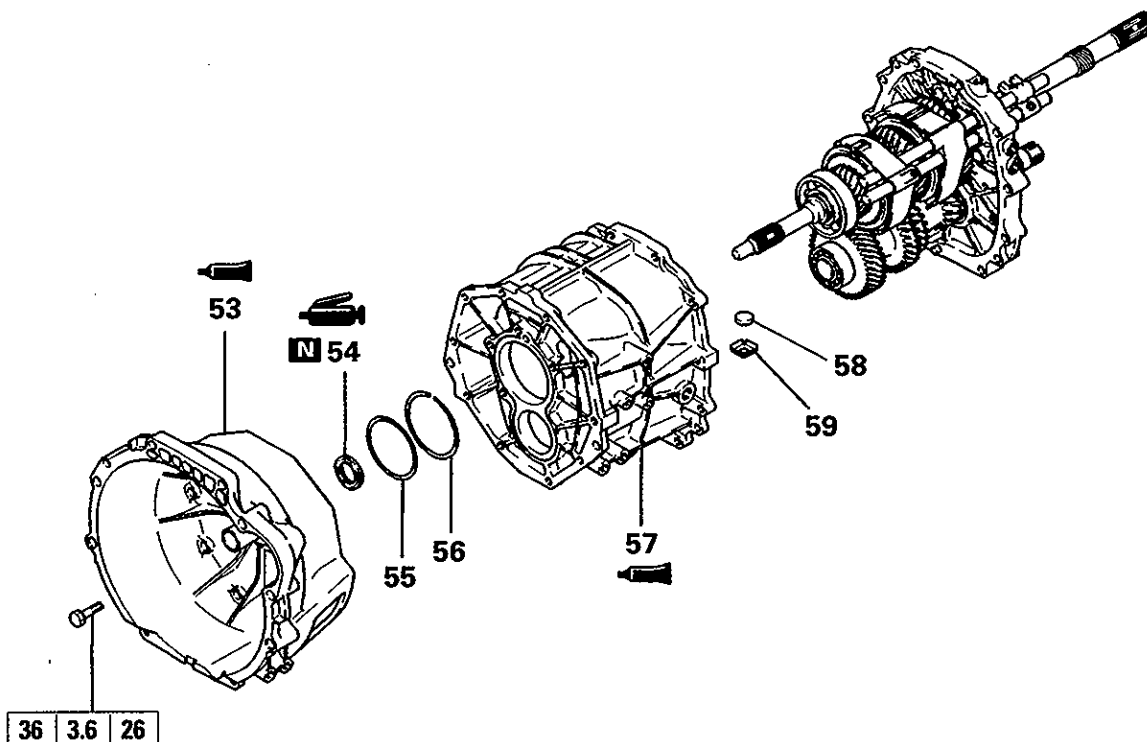

Disassembly steps

- ◆I◆ 53. Clutch housing
- ◆H◆ 54. Oil seal
- ◆G◆ 55. Spacer
- 56. Snap ring
- ◆F◆ 57. Transmission case
- ◆D◆ 58. Magnet
- ◆D◆ 59. Magnet holder

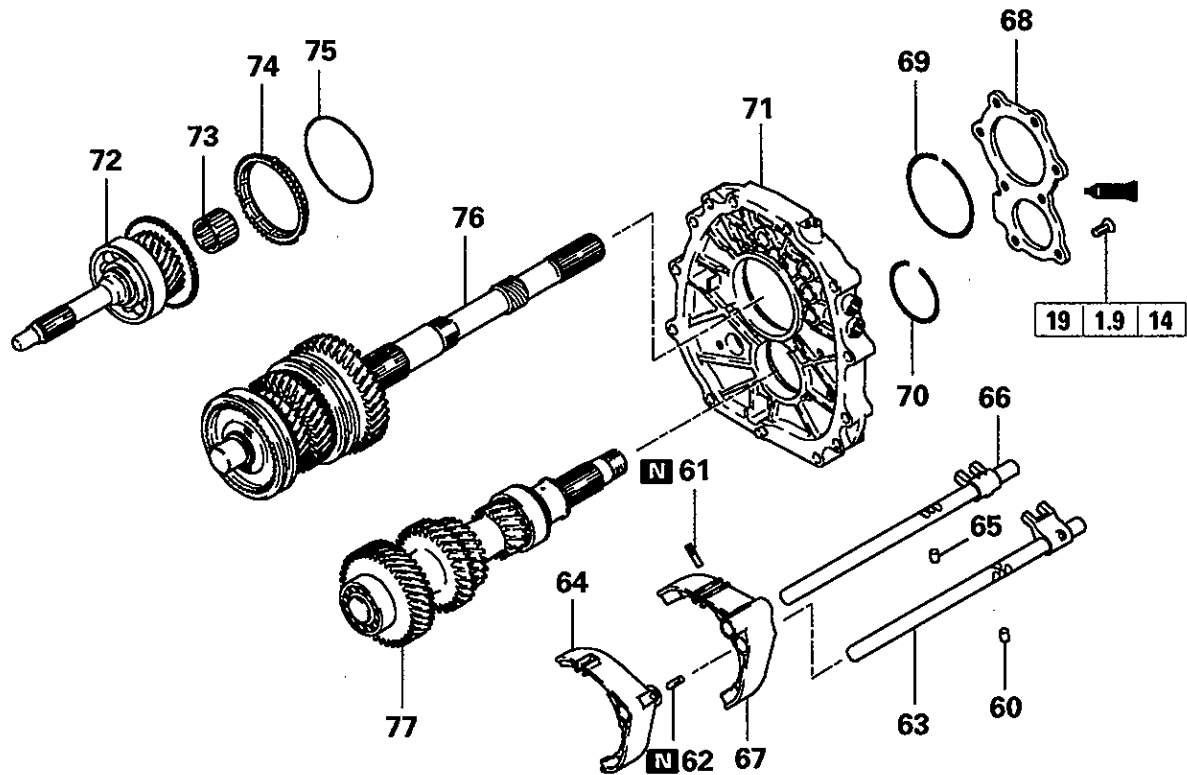

 Apply gear oil to all moving parts before installation.

Disassembly steps

- 60. Interlock plunger
- ▶C▶ 61. Spring pin
- ▶C▶ 62. Spring pin
- 63. 3rd-4th speed shift rail
- 64. 3rd-4th speed shift fork
- 65. Interlock plunger
- 66. 1st-2nd speed shift rail
- 67. 1st-2nd speed shift fork
- ▶B▶ 68. Rear bearing retainer
- ◊E◊ 69. Snap ring
- ◊E◊ 70. Snap ring
- ◊F◊ ▶A▶ 71. Intermediate plate
- 72. Main drive pinion
- 73. Needle bearing
- 74. Synchronizer ring
- 75. Synchronizer spring
- 76. Main shaft
- 77. Countershaft cluster gear

<R5M31-B (Floor shift type)>

Apply gear oil to all moving parts before installation.

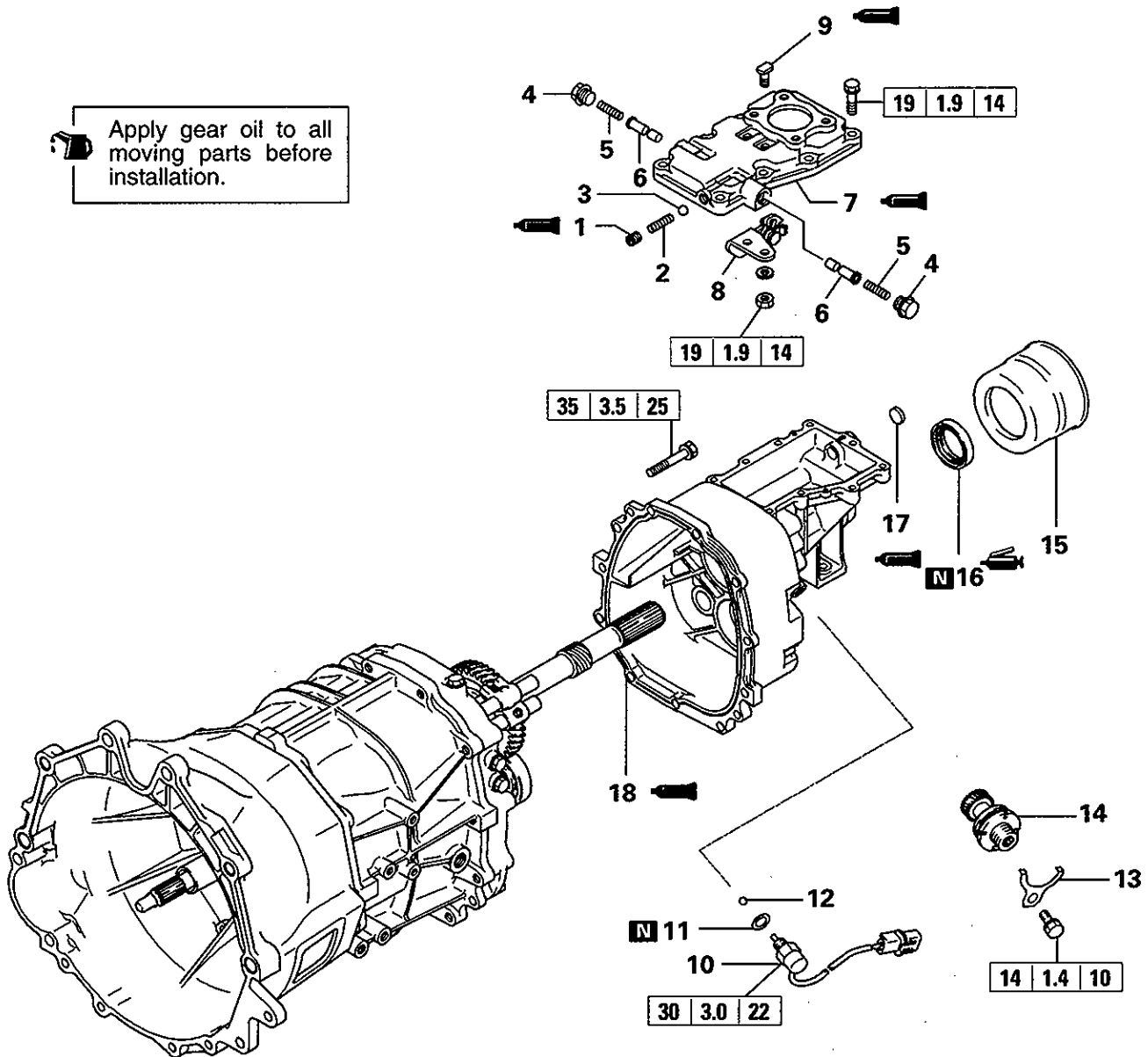

Disassembly steps

- | | | |
|------|--------------------------------|-----------------------|
| ◆AB◆ | 1. Resistance spring plug | 10. Backlight switch |
| | 2. Resistance spring | 11. Gasket |
| | 3. Steel ball | 12. Steel ball |
| ◆AA◆ | 4. Neutral return plunger plug | 13. Sleeve clamp |
| | 5. Neutral return spring | ◆AK◆ |
| | 6. Neutral return plunger | 14. Speedometer gear |
| ◆AM◆ | 7. Control housing | 15. Dust seal guard |
| | 8. Stopper bracket | ◆AJ◆ |
| ◆AL◆ | 9. Special bolt | 16. Oil seal |
| | | ◆AI◆ |
| | | 17. Control shaft cap |
| | | ◆AE◆ |
| | | 18. Extension housing |

Apply gear oil to all moving parts before installation.

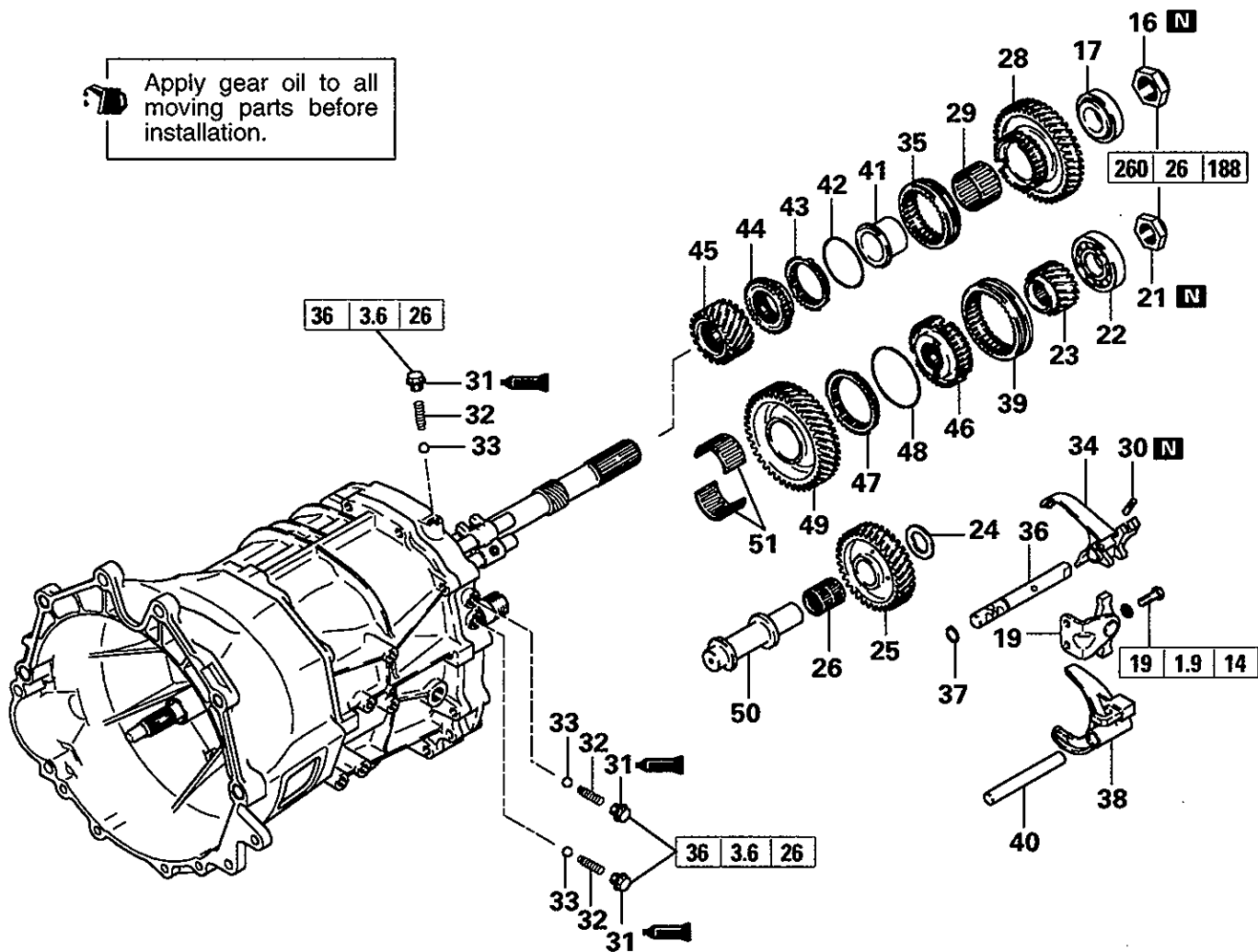

Disassembly steps

- 19. 5th speed shift lever
- ◊A◊▶Y◊ 20. Lock nut
- ◊A◊▶Y◊ 21. Lock nut
- ◊B◊▶W◊ 22. Ball bearing
- ▶V◊ 23. Counter reverse gear
- 24. Thrust washer
- ▶U◊ 25. Reverse idler gear
- 26. Needle bearing
- ◊C◊▶T◊ 27. Ball bearing
- ▶S◊ 28. Reverse gear
- 29. Needle bearing
- ▶C◊ 30. Spring pin
- ▶R◊ 31. Poppet plug
- ▶Q◊ 32. Poppet spring
- 33. Steel ball
- 34. Reverse shift fork
- ▶P◊ 35. Reverse synchronizer sleeve

- 36. Reverse shift rail
- 37. Snap ring
- 38. 5th speed shift fork
- ▶O◊ 39. 5th speed synchronizer sleeve
- ◊D◊▶N◊ 40. 5th speed shift rail
- 41. Reverse gear bearing sleeve
- 42. Synchronizer spring
- 43. Synchronizer ring
- ▶M◊ 44. Reverse brake gear
- ▶L◊ 45. Overtop gear
- ▶K◊ 46. 5th speed synchronizer hub
- 47. Synchronizer ring
- 48. Synchronizer spring
- ▶J◊ 49. Counter 5th speed gear
- 50. Reverse idler gear shaft
- 51. Needle bearing

Apply gear oil to all moving parts before installation.

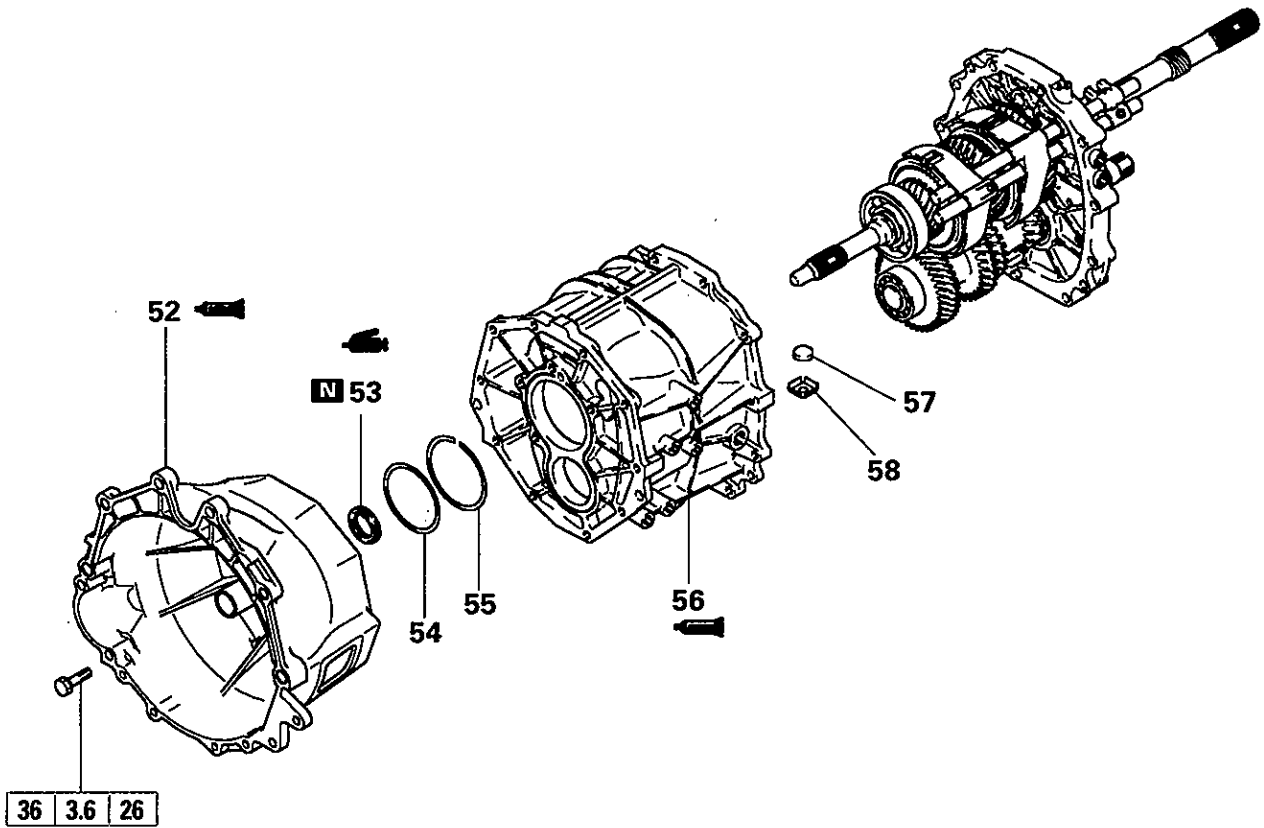

Disassembly steps

- ▶I 52. Clutch housing
- ▶H 53. Oil seal
- ▶G 54. Spacer
- 55. Snap ring
- ▶F 56. Transmission case
- ▶D 57. Magnet
- ▶D 58. Magnet holder

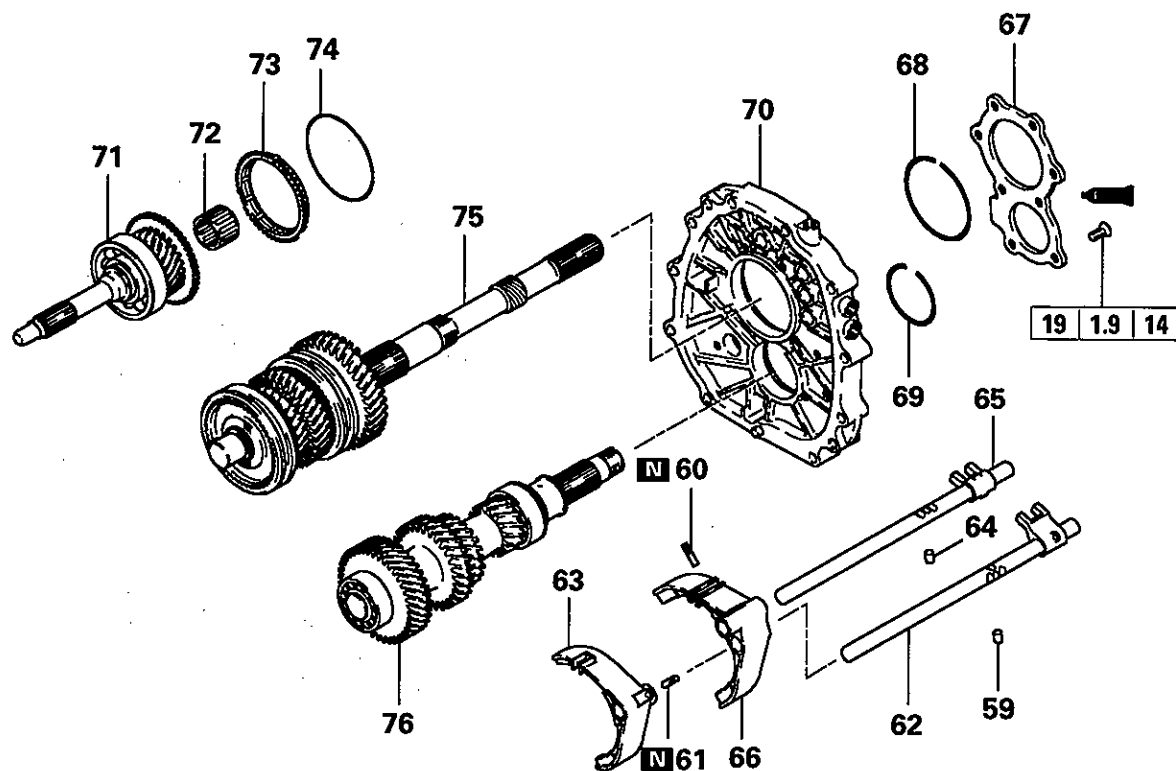

 Apply gear oil to all moving parts before installation.

Disassembly steps

- 59. Interlock plunger
- ▶C▶ 60. Spring pin
- ▶C▶ 61. Spring pin
- 62. 3rd-4th speed shift rail
- 63. 3rd-4th speed shift fork
- 64. Interlock plunger
- 65. 1st-2nd speed shift rail
- 66. 1st-2nd speed shift fork
- ▶B▶ 67. Rear bearing retainer
- ◊E◊ 68. Snap ring
- ◊E◊ 69. Snap ring
- ◊F◊ ▶A▶ 70. Intermediate plate
- 71. Main drive pinion
- 72. Needle bearing
- 73. Synchronizer ring
- 74. Synchronizer spring
- 75. Main shaft
- 76. Countershaft cluster gear

DISASSEMBLY AND REASSEMBLY

<V5M31-6 SUPER SELECT 4WD II>

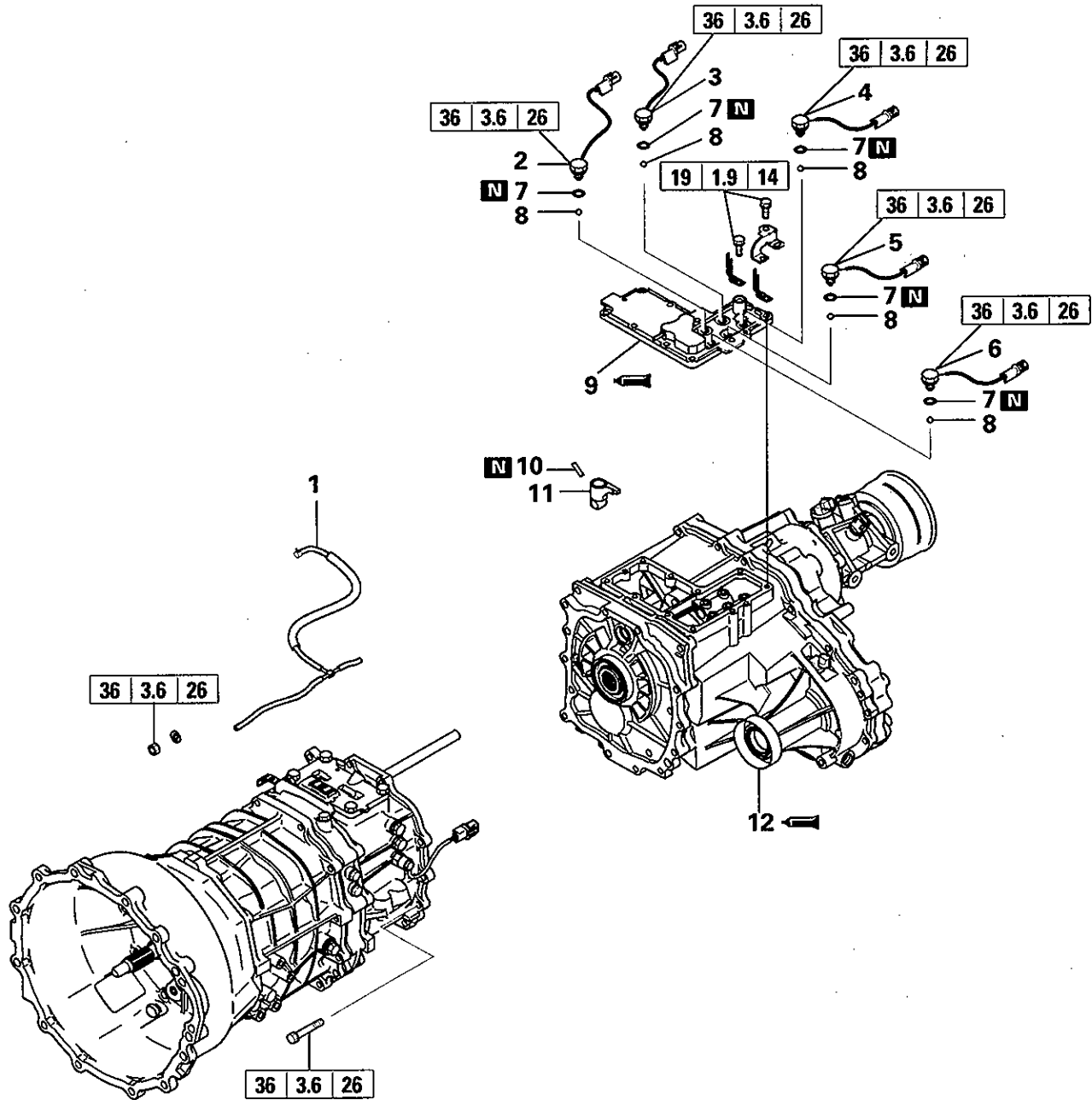

Disassembly steps

- 1. Vacuum hose
- ▶AT▶ 2. 4LLC switch
- ▶AT▶ 3. 2WD switch
- ▶AT▶ 4. Center differential lock switch
- ▶AT▶ 5. 4H switch
- ▶AT▶ 6. 2WD-4WD switch
- 7. Gasket
- 8. Steel ball
- ▶AS▶ 9. Control housing
- ▶C▶ 10. Spring Pin
- 11. Change shifter
- ▶AD▶ 12. Transfer



Apply gear oil to all moving parts before installation.

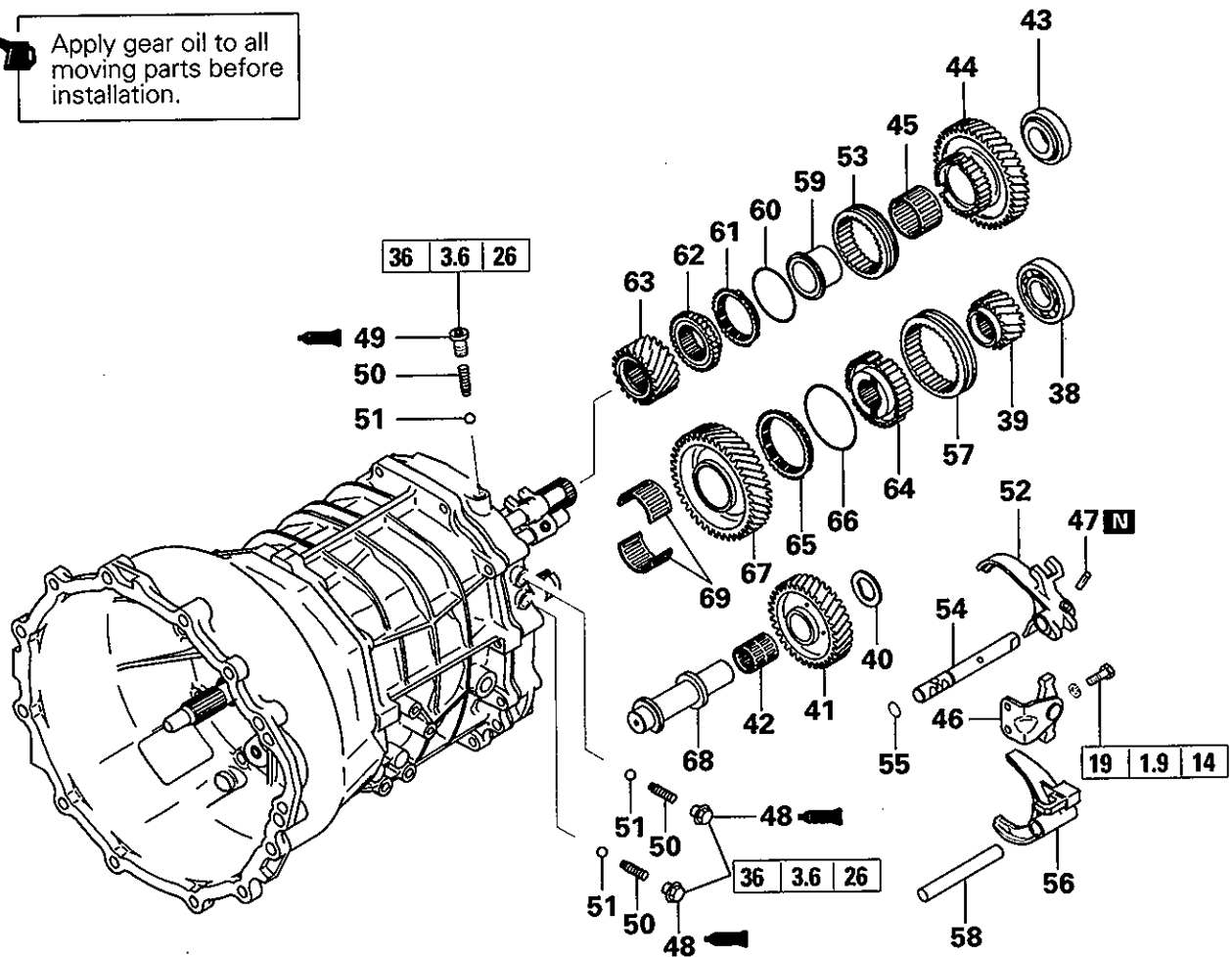

Disassembly steps

- ◁B▷ ▶W▶ 38. Ball bearing
- ▶V▶ 39. Counter reverse gear
- ▶U▶ 40. Thrust washer
- ▶U▶ 41. Reverse idler gear
- ▶U▶ 42. Needle bearing
- ◁C▷ ▶T▶ 43. Ball bearing
- ▶S▶ 44. Reverse gear
- ▶S▶ 45. Needle bearing
- ▶C▶ 46. 5th speed shift lever
- ▶C▶ 47. Spring pin
- ▶R▶ 48. Poppet plug "B"
- ▶AN▶ 49. Poppet plug "A"
- ▶Q▶ 50. Poppet spring
- ▶Q▶ 51. Steel ball
- ▶P▶ 52. Reverse shift fork
- ▶P▶ 53. Reverse synchronizer sleeve
- ▶P▶ 54. Reverse shift rail
- ▶O▶ 55. Snap ring
- ▶O▶ 56. 5th speed shift fork
- ▶O▶ 57. 5th speed synchronizer sleeve
- ▶O▶ 58. 5th speed shift rail
- ◁D▷ ▶N▶ 59. Reverse gear bearing sleeve
- ▶M▶ 60. Synchronizer ring
- ▶M▶ 61. Synchronizer ring
- ▶L▶ 62. Reverse brake gear
- ▶L▶ 63. Overtop gear
- ▶K▶ 64. 5th synchronizer hub
- ▶J▶ 65. Synchronizer ring
- ▶J▶ 66. Synchronizer spring
- ▶J▶ 67. Counter 5th speed gear
- ▶J▶ 68. Reverse idler gear shaft
- ▶J▶ 69. Needle bearing

 Apply gear oil to all moving parts before installation.

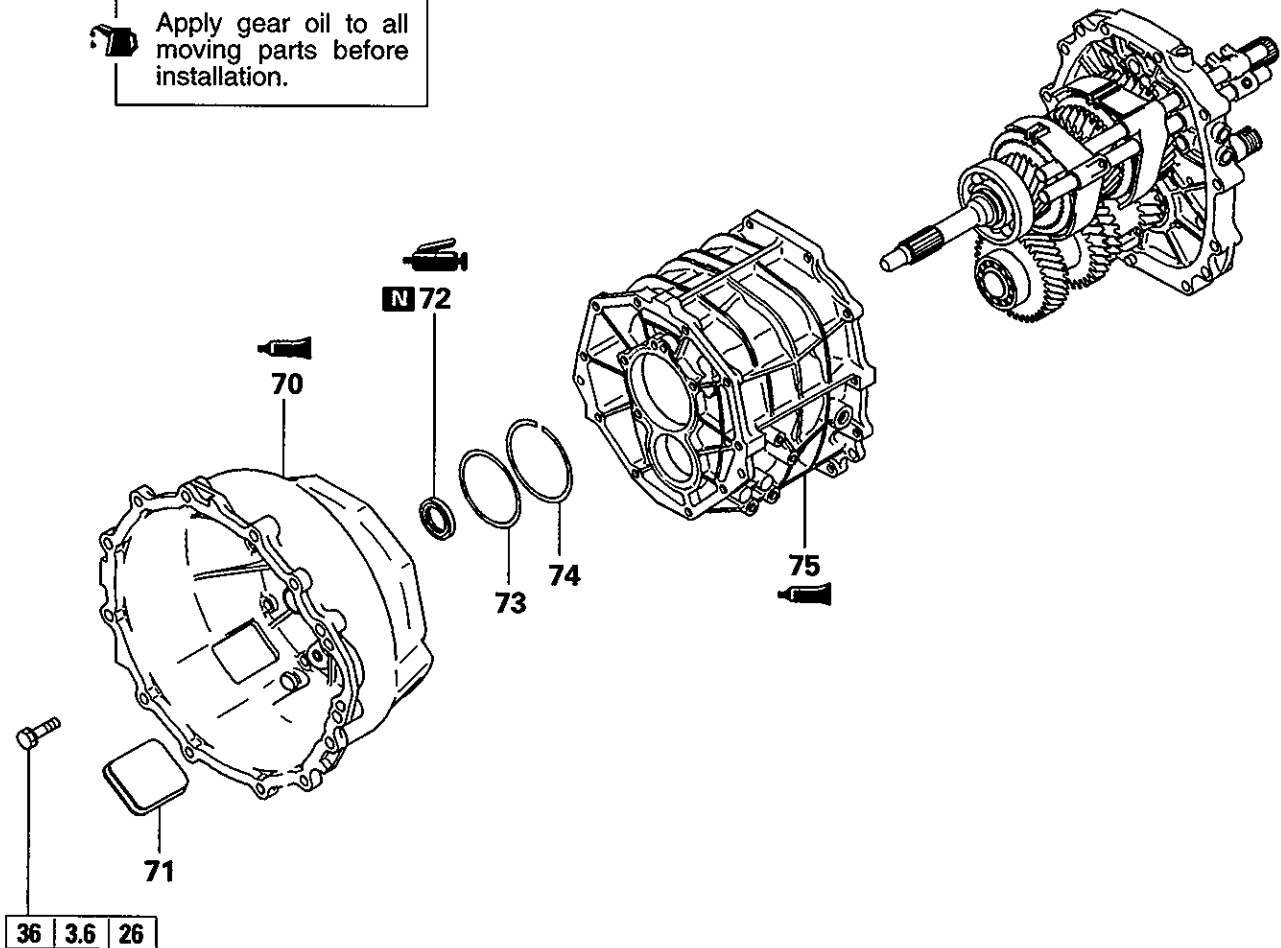

Disassembly steps

- ▶ 70. Clutch housing
- ▶ 71. Inspection hole cover
- ▶ 72. Oil seal
- ▶ 73. Spacer
- ▶ 74. Snap ring
- ▶ 75. Transmission case

Apply gear oil to all moving parts before installation.

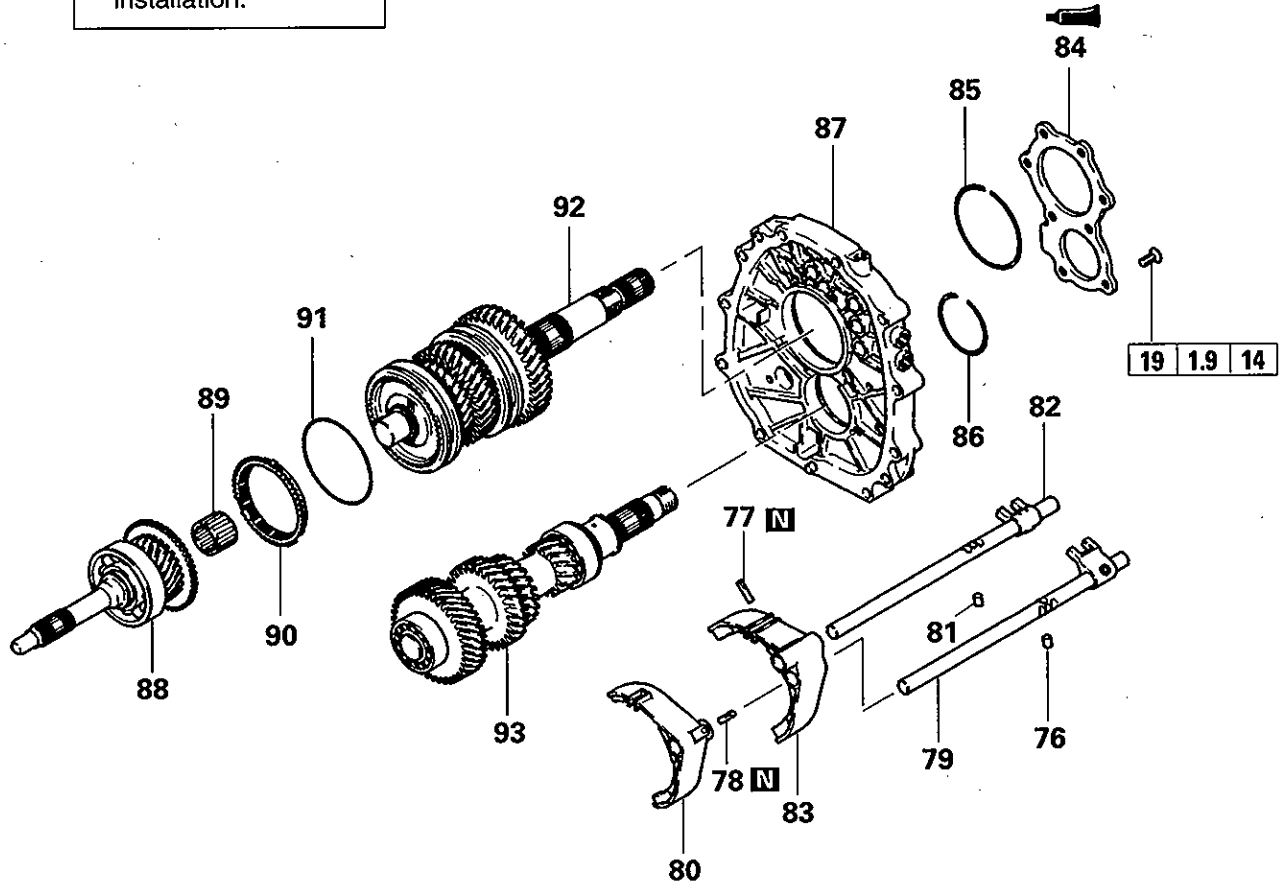

Disassembly steps

- 76. Interlock plunger
- ▶C▶ 77. Spring pin
- ▶C▶ 78. Spring pin
- 79. 3rd-4th speed shift rail
- 80. 3rd-4th speed shift fork
- 81. Interlock plunger
- 82. 1st-2nd speed shift rail
- 83. 1st-2nd speed shift fork
- ▶B▶ 84. Rear bearing retainer
- ◁E▷ 85. Snap ring
- ◁E▷ 86. Snap ring
- ◁F▷ ▶A▶ 87. Intermediate plate
- 88. Main drive pinion
- 89. Needle bearing
- 90. Synchronizer ring
- 91. Synchronizer spring
- 92. Main shaft
- 93. Countershaft cluster gear

DISASSEMBLY AND REASSEMBLY

<V5M31-6 PART TIME 4WD>

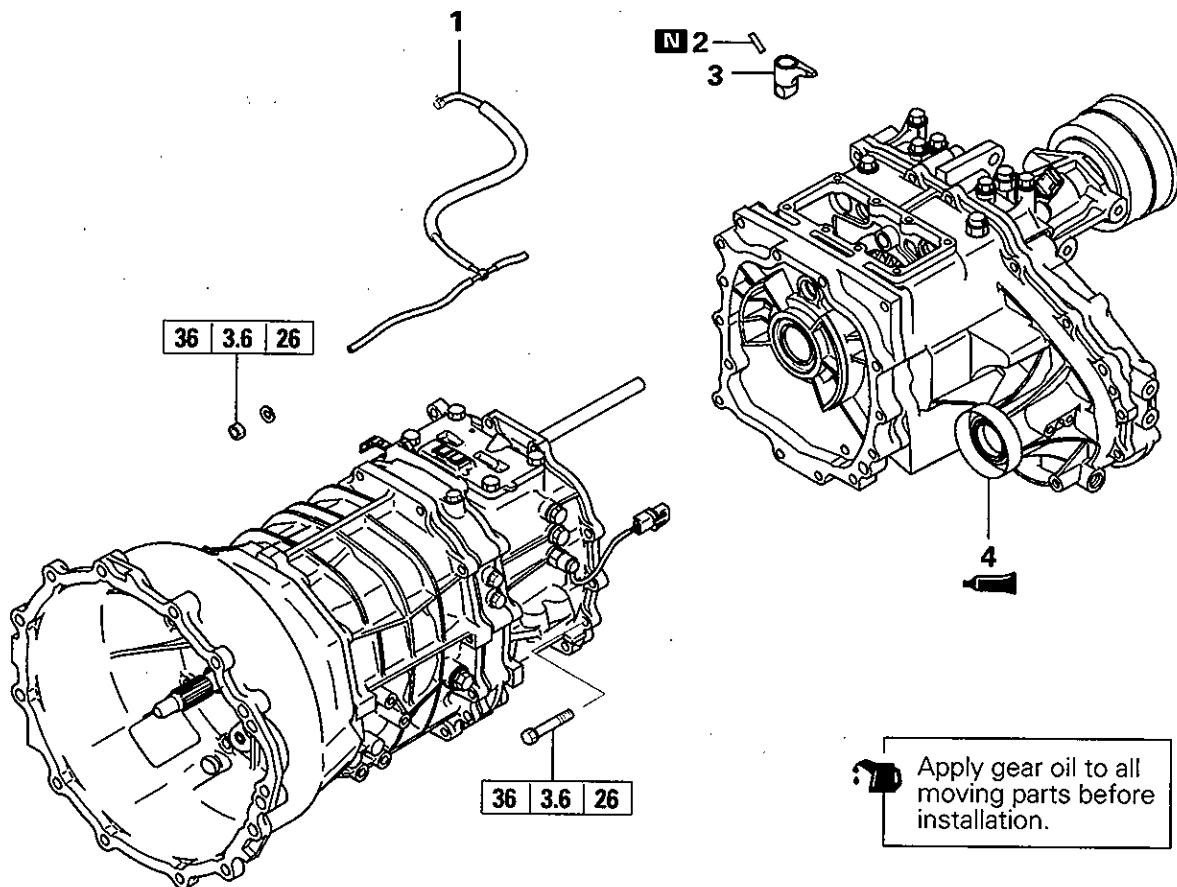
**Disassembly steps**

- 1. Vacuum hose
- ↗C↖ 2. Spring Pin
- 3. Change shifter
- ↗AD↖ 4. Transfer

Apply gear oil to all moving parts before installation.

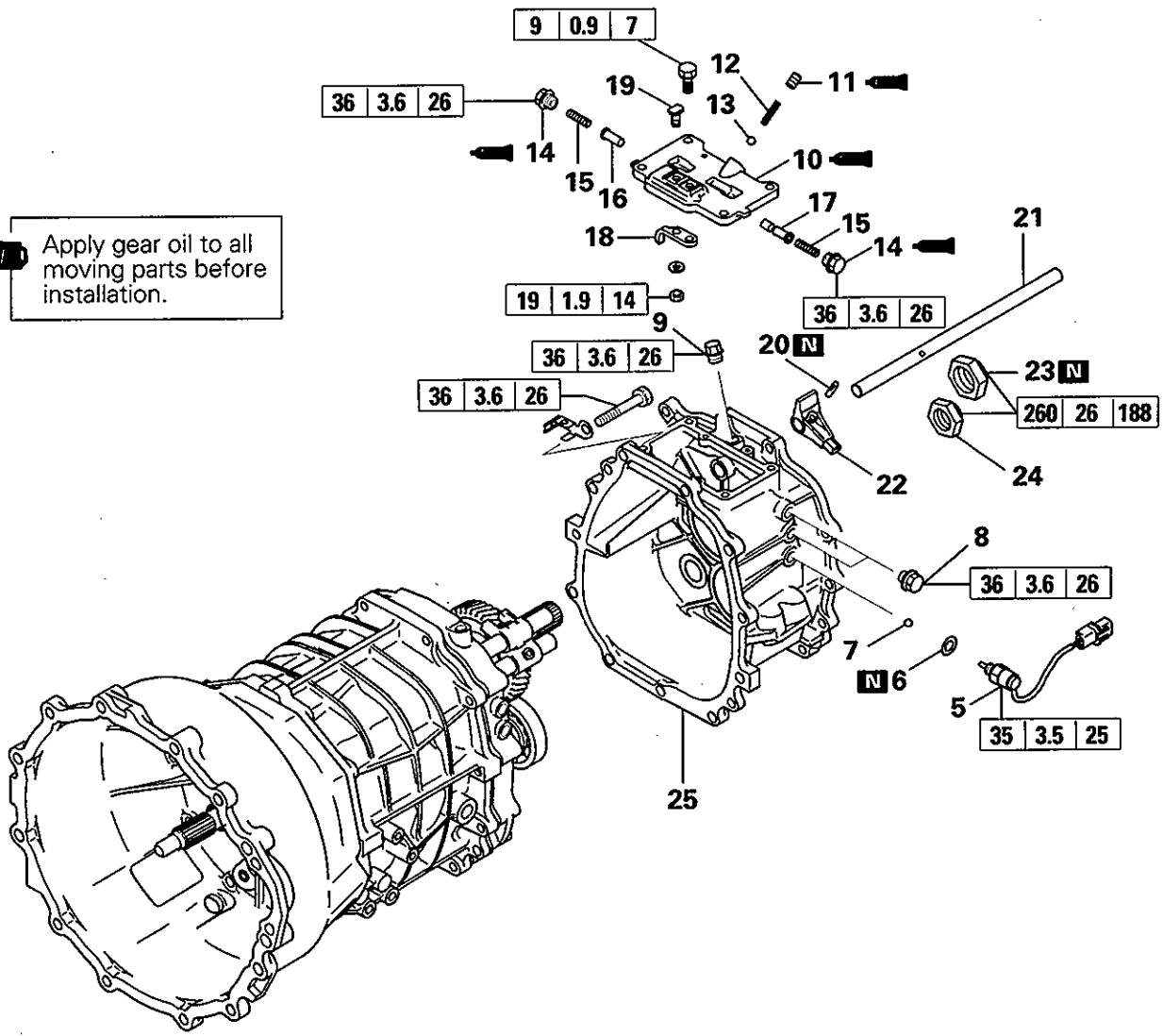

Disassembly steps

- ▶AR▶ 5. Backlight switch
- ▶R▶ 6. Gasket
- ▶AQ▶ 7. Steel ball
- ▶AP▶ 8. Poppet plug "B"
- ▶AB▶ 9. Seal plug (V5M31-6-M, N, S, W, Y)
- ▶AB▶ 10. Upper cover
- ▶AB▶ 11. Plug
- ▶AB▶ 12. Resistance spring
- ▶AO▶ 13. Steel ball
- ▶AO▶ 14. Seal bolt
- ▶AO▶ 15. Neutral return spring
- ▶AM▶ 16. Neutral return plunger A
- ▶AM▶ 17. Neutral return plunger B
- ▶AM▶ 18. Stopper bracket
- ▶AM▶ 19. Special bolt
- ▶C▶ 20. Spring pin
- ▶C▶ 21. Control shaft
- ▶C▶ 22. Control finger
- ▶A▶▶Y▶ 23. Lock nut
- ▶A▶▶Y▶ 24. Lock nut
- ▶X▶ 25. Transfer case adapter

Apply gear oil to all moving parts before installation.

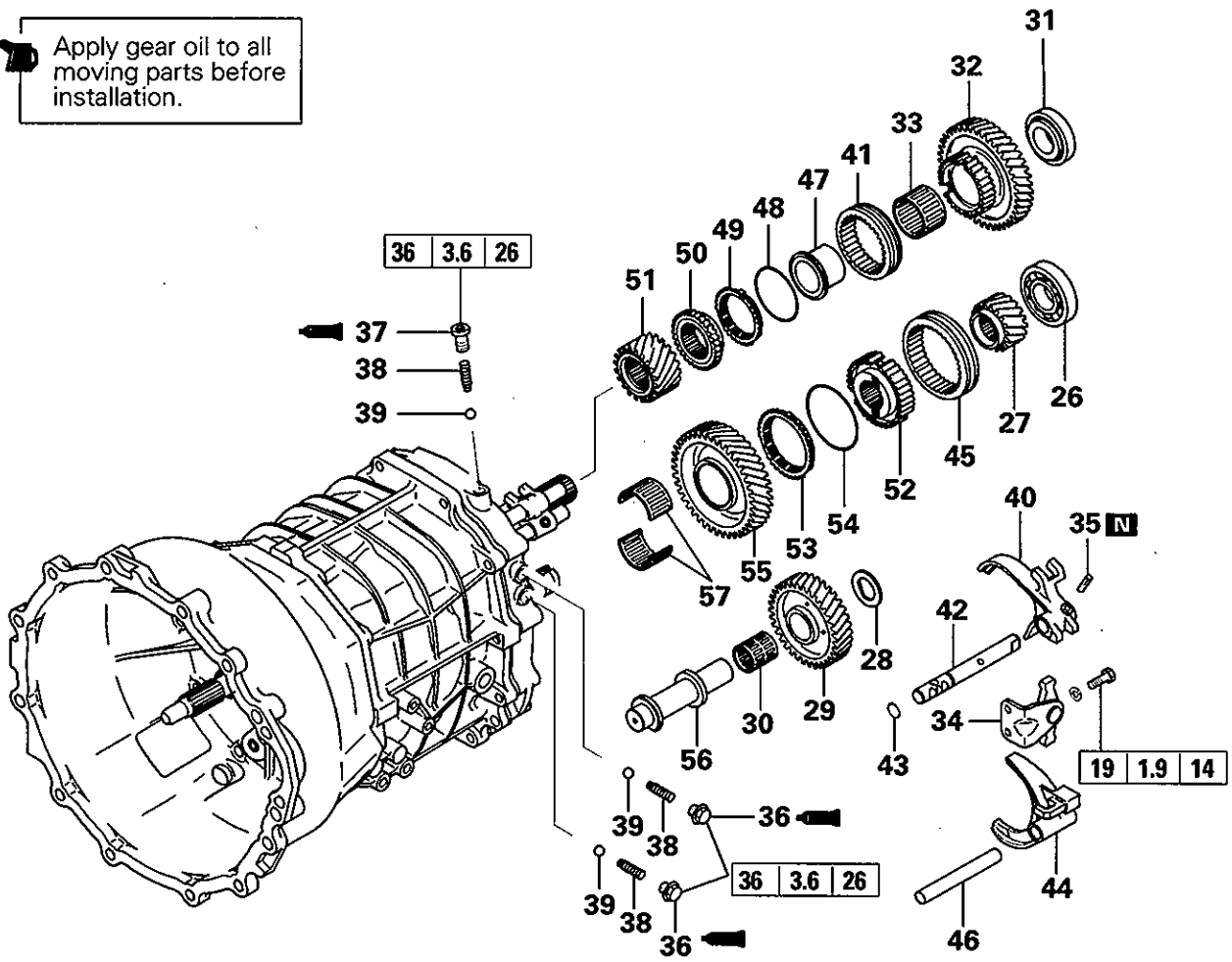

Disassembly steps

- ◊B◊ ◊W◊ 26. Ball bearing
- ◊V◊ 27. Counter reverse gear
- ◊U◊ 29. Reverse idler gear
- ◊C◊ ◊T◊ 31. Ball bearing
- ◊S◊ 32. Reverse gear
- ◊M◊ 33. Needle bearing
- ◊R◊ 36. Poppet plug "B"
- ◊AN◊ 37. Poppet plug "A"
- ◊Q◊ 38. Poppet spring
- ◊P◊ 41. Reverse synchronizer sleeve
- 40. Reverse shift fork
- 42. Reverse shift rail

- 43. Snap ring
- 44. 5th speed shift fork
- ◊O◊ 45. 5th speed synchronizer sleeve
- ◊D◊ ◊N◊ 47. Reverse gear bearing sleeve
- 48. Synchronizer spring
- 49. Synchronizer ring
- ◊L◊ 50. Reverse brake gear
- ◊K◊ 51. Overtop gear
- 52. 5th synchronizer hub
- 53. Synchronizer ring
- 54. Synchronizer spring
- ◊J◊ 55. Counter 5th speed gear
- 56. Reverse idler gear shaft
- 57. Needle bearing

 Apply gear oil to all moving parts before installation.

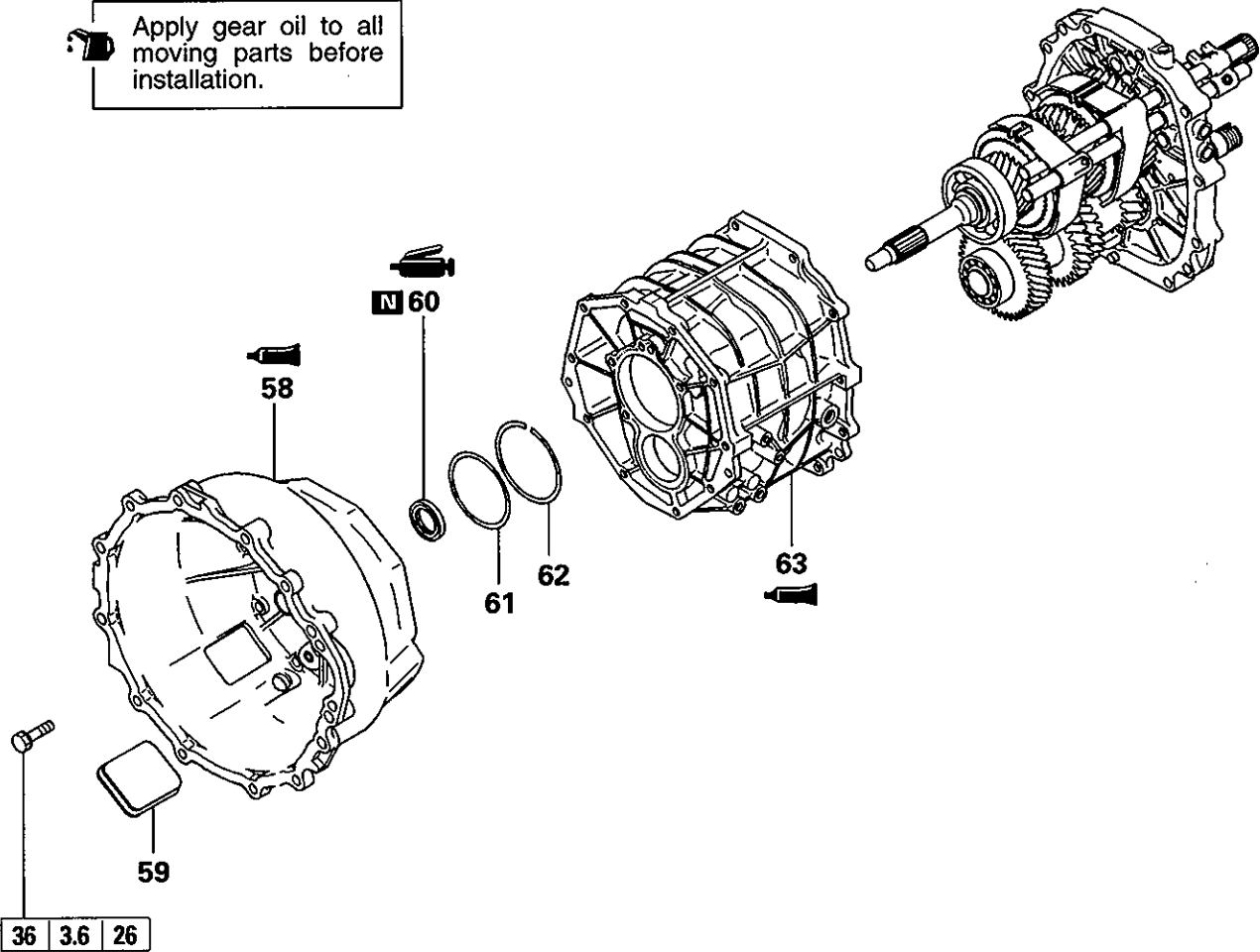

Disassembly steps

- ▶I 58. Clutch housing
- ▶I 59. Inspection hole cover
- ▶H 60. Oil seal
- ▶G 61. Spacer
- ▶G 62. Snap ring
- ▶F 63. Transmission case

 Apply gear oil to all moving parts before installation.

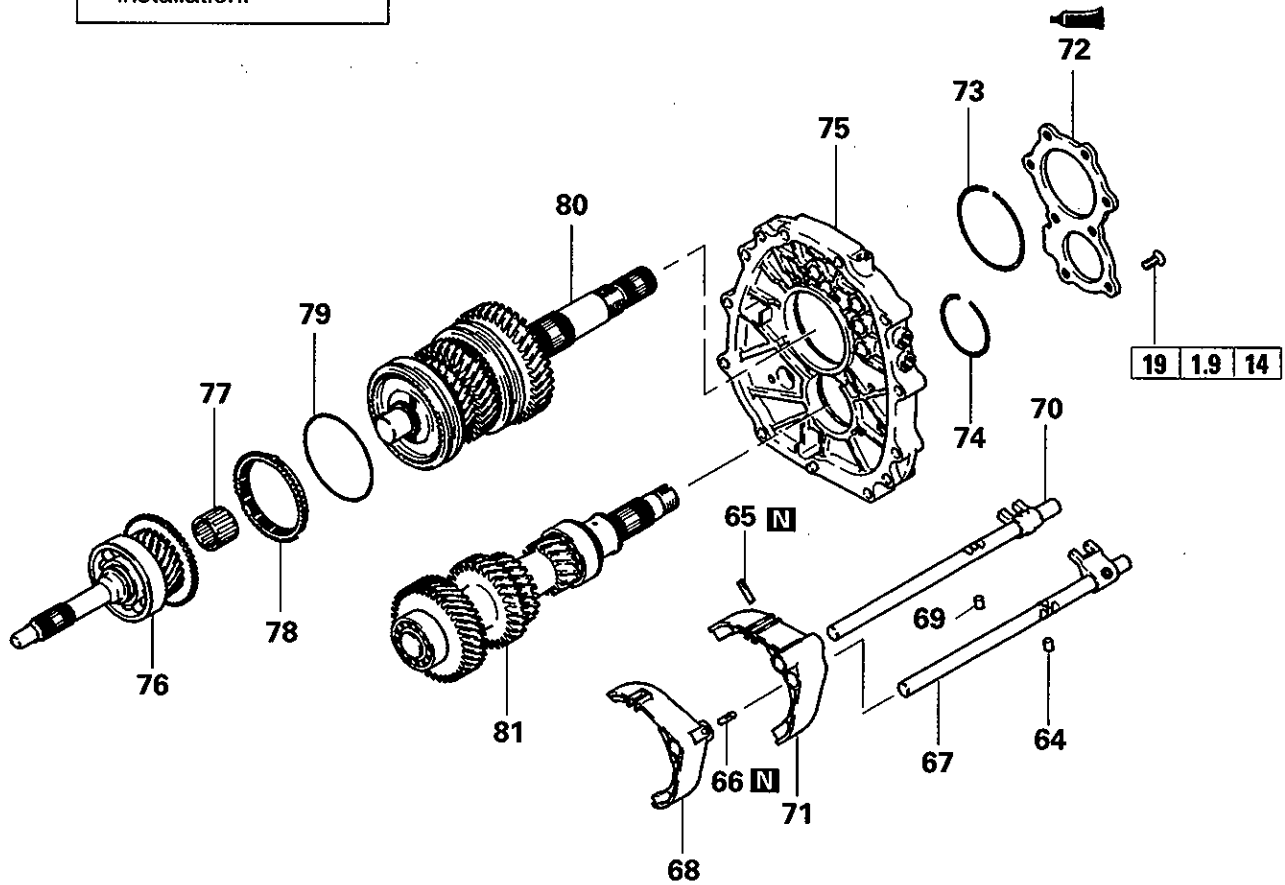

Disassembly steps

- 64. Interlock plunger
- ▶C▶ 65. Spring pin
- ▶C▶ 66. Spring pin
- 67. 3rd-4th speed shift rail
- 68. 3rd-4th speed shift fork
- 69. Interlock plunger
- 70. 1st-2nd speed shift rail
- 71. 1st-2nd speed shift fork
- ▶B▶ 72. Rear bearing retainer
- ◊E◊ 73. Snap ring
- ◊E◊ 74. Snap ring
- ◊F◊ ▶A▶ 75. Intermediate plate
- 76. Main drive pinion
- 77. Needle bearing
- 78. Synchronizer ring
- 79. Synchronizer spring
- 80. Main shaft
- 81. Countershaft cluster gear

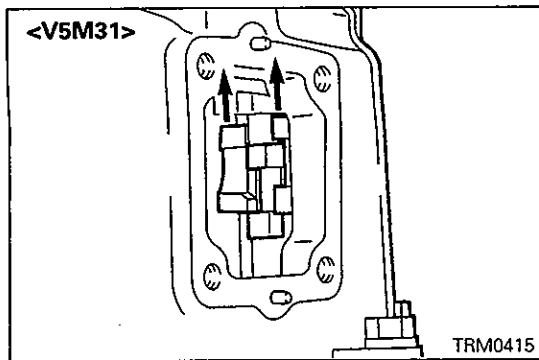
**DISASSEMBLY SERVICE POINTS****◁A▷ LOCK NUT REMOVAL**

- (1) Slide the shift forks as illustrated to put the two speed gears into engagement. <V5M31>

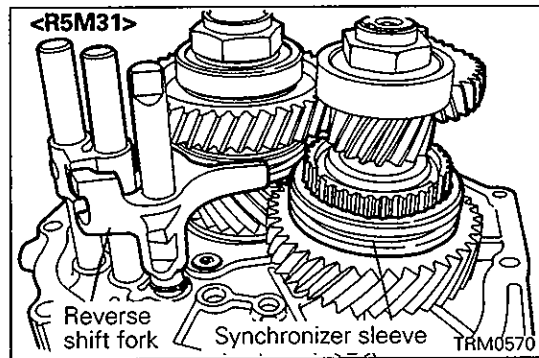

- (2) Shift the reverse shift fork and the 5th synchronizer sleeve as shown in the illustration to engage gears to fix the shaft. <R5M31>

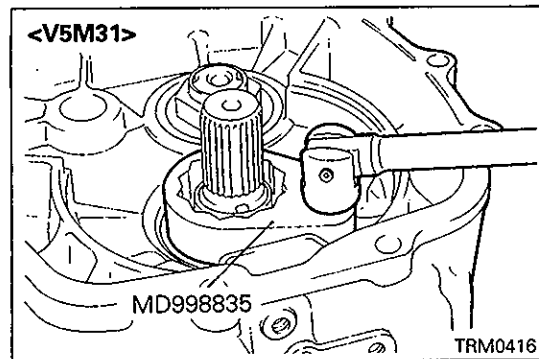

- (3) Remove the main shaft lock nut using the special tool.

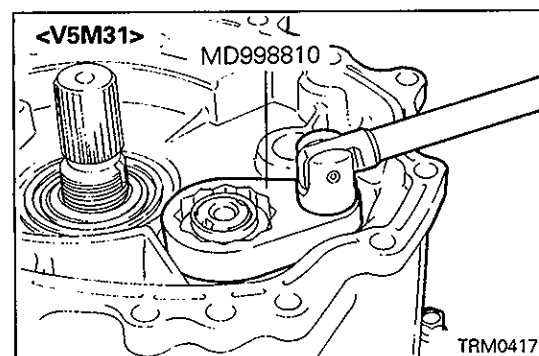
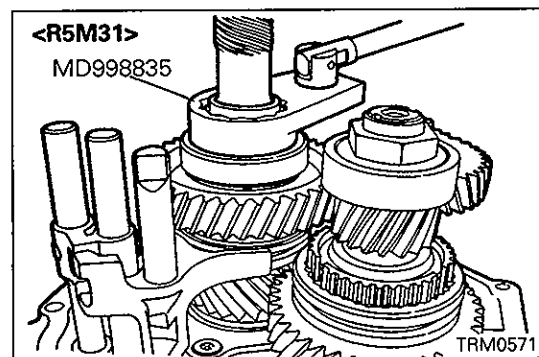

- (4) Remove the lock nut on the countershaft cluster gear using the special tool.

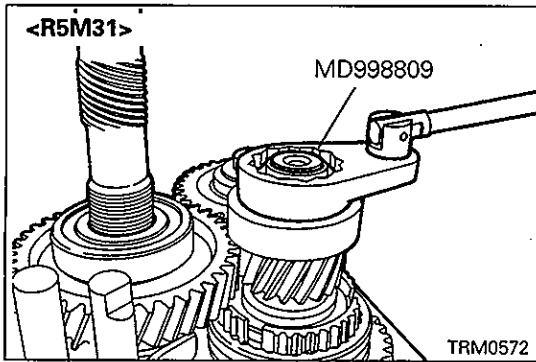

◁B▷ **BALL BEARING REMOVAL**

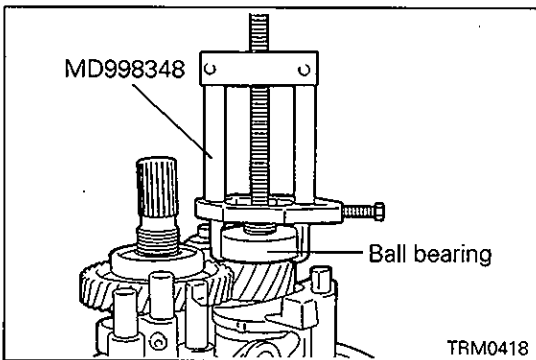

◁C▷ **BALL BEARING REMOVAL**

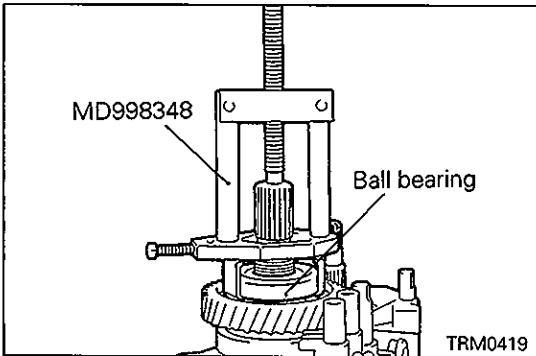

◁D▷ **REVERSE GEAR BEARING SLEEVE REMOVAL**

- (1) Attach the special tool to the reverse brake gear, then remove the reverse gear bearing sleeve and the synchronizer spring and ring together.

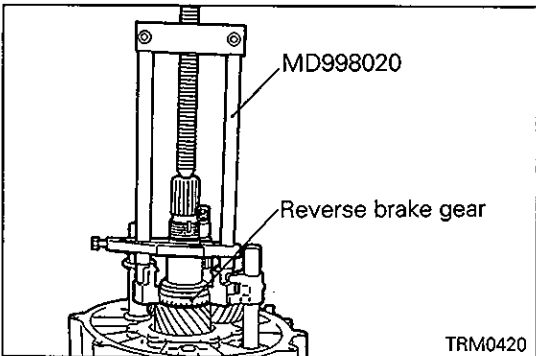

◁E▷ **SNAP RING REMOVAL**

- (1) While pushing the main shaft and countershaft cluster gear against the intermediate plate, remove the snap rings from the rear bearing retainer mounting surface.

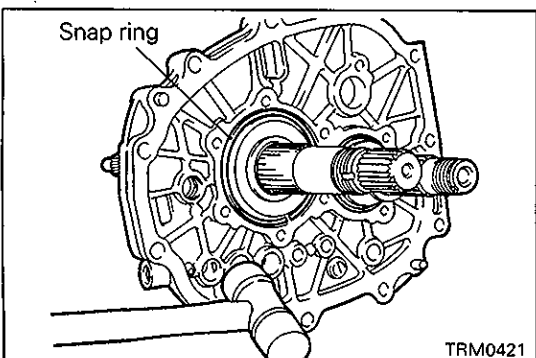

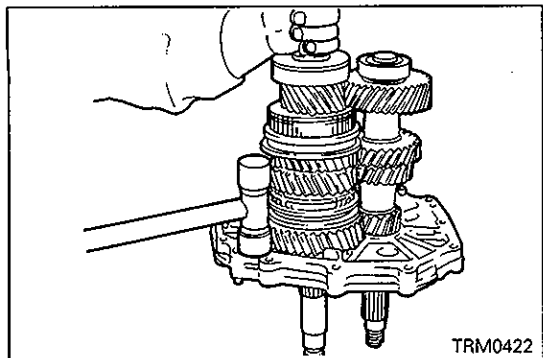

⇄ INTERMEDIATE PLATE REMOVAL

Caution

- Removing the intermediate plate will set free the main shaft, countershaft cluster gear and main drive pinion at the same time.

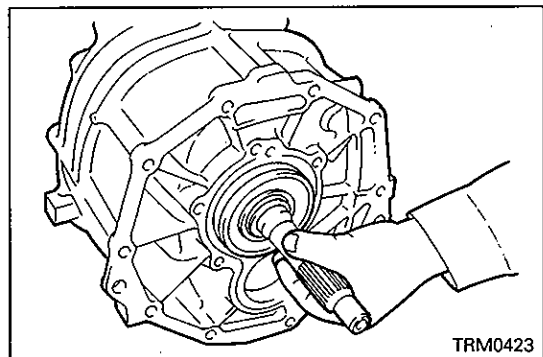

ADJUSTMENT BEFORE REASSEMBLY SPACER SELECTION FOR MAIN DRIVE PINION END PLAY ADJUSTMENT

- (1) Install the main drive pinion to the transmission case.

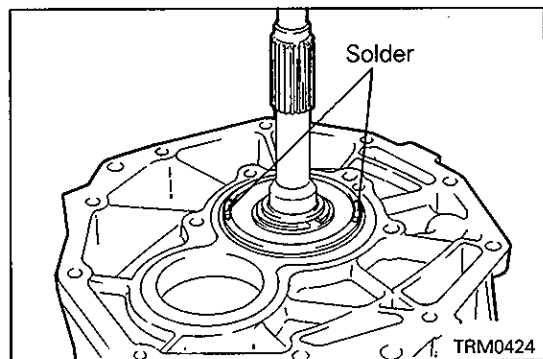

- (2) Place two pieces of solder measuring about 10 mm (0.39 in.) in length and 1.6 mm (0.063 in.) in diameter on the ball bearing as illustrated.
- (3) Install the clutch housing and tighten the bolts to the specified torque.
- (4) If the solders have not been crushed, repeat steps (2) and (3) with larger diameter pieces.

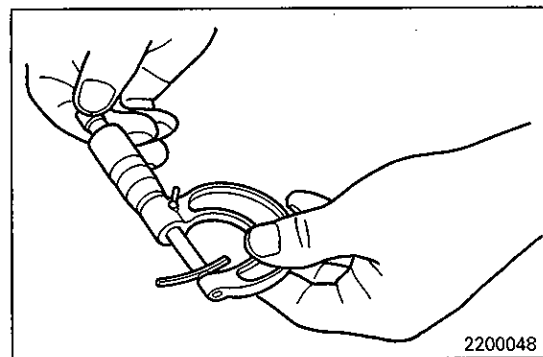

- (5) Measure the thickness of the crushed solder with a micrometer and select a spacer of thickness that gives standard end play.

Standard value: 0 – 0.1 mm (0 – 0.04 in.)

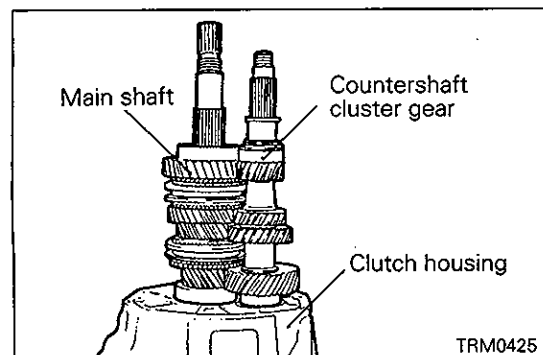

REASSEMBLY SERVICE POINTS

◆◆ INTERMEDIATE PLATE INSTALLATION

- (1) Install the main shaft and the countershaft cluster gear to the clutch housing.

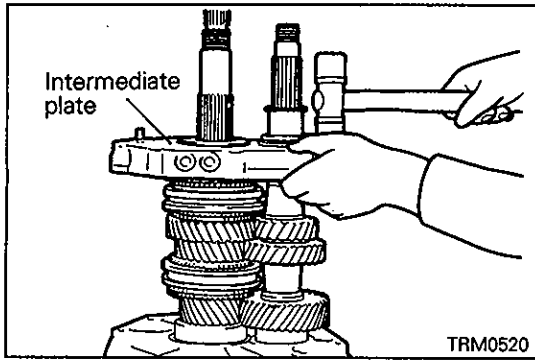

- (2) Using a plastic hammer, install the intermediate plate.

NOTE

Push the intermediate plate until the snap ring grooves for the main shaft and countershaft cluster gear bearings come out of the rear bearing retainer mounting surface.

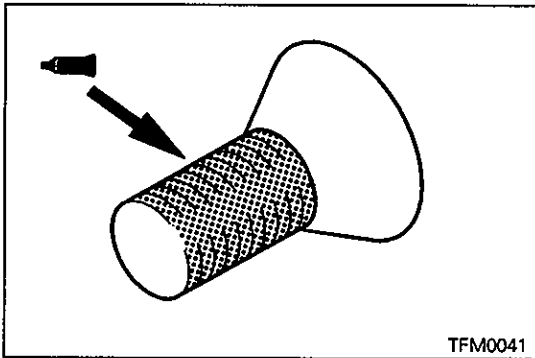

▶B◀ REAR BEARING RETAINER INSTALLATION

- (1) The rear bearing retainer mounting bolt is a precoated one. When it is to be reused, apply a sealant to the bolt beforehand.

Specified sealant:

3M STUD Locking No. 4170 or equivalent

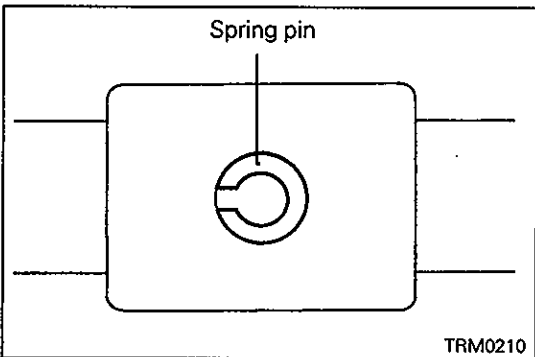

▶C◀ SPRING PIN INSTALLATION

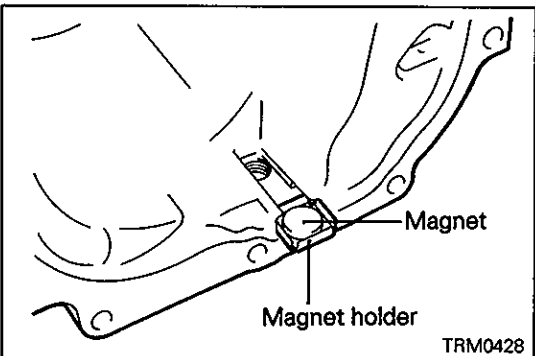

▶D◀ MAGNET HOLDER / MAGNET INSTALLATION

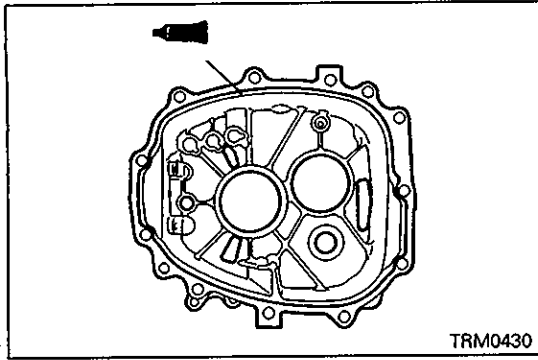

▶F◀ TRANSMISSION CASE INSTALLATION

- (1) Apply sealant to the transmission case as illustrated.

Specified sealant:

Mitsubishi genuine sealant Part No. MD997740 or equivalent

Caution

- Squeeze sealant out evenly to make sure that it is not broken or excessively supplied.

▶G◀ SPACER INSTALLATION

- (1) Install the previously selected spacer (see "ADJUSTMENT BEFORE REASSEMBLY").

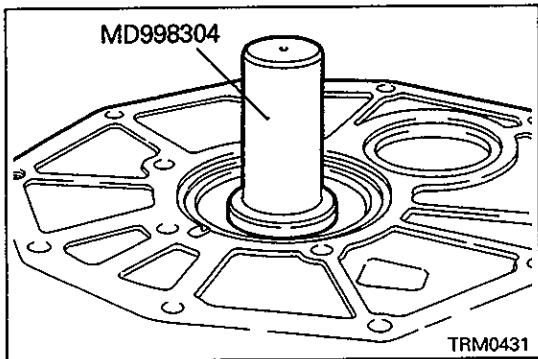

▶H◀ OIL SEAL INSTALLATION

- (1) After installing the oil seal, apply grease to the oil seal lips.

Specified grease:

Mitsubishi genuine grease Part No.0101011 or equivalent

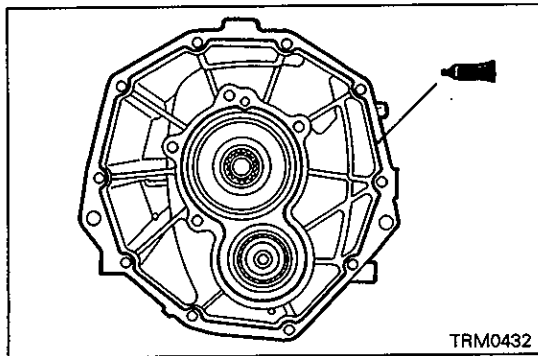

▶I◀ CLUTCH HOUSING INSTALLATION

- (1) Apply a bead of sealant to the transmission case as illustrated.

Specified sealant:

Mitsubishi genuine sealant Part No. MD997740 or equivalent

Caution

- Squeeze sealant out evenly to make sure that it is not broken or excessively supplied.
- Be careful not to damage the oil seal by the spline of the main drive pinion.

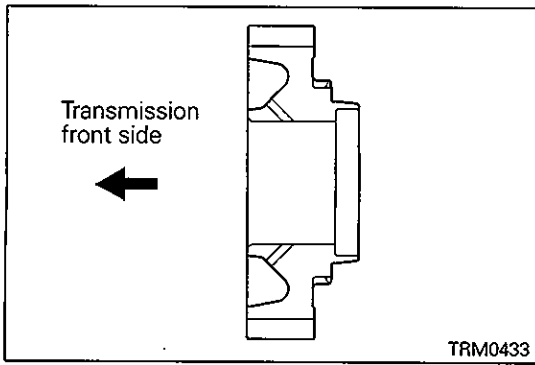

▶J◀ COUNTER 5TH SPEED GEAR INSTALLATION

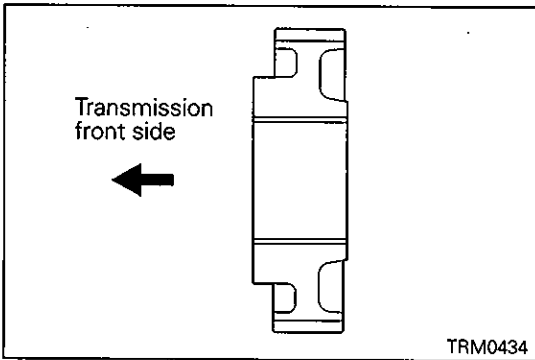

▶K◀ 5TH SPEED SYNCHRONIZER HUB INSTALLATION

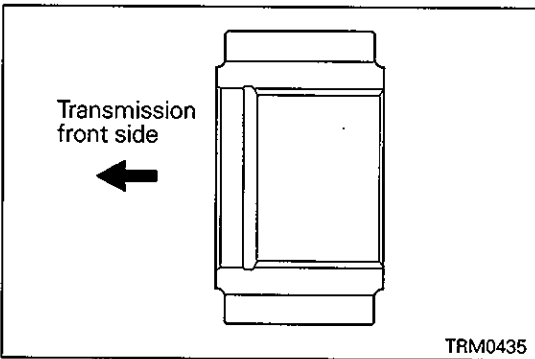

▶L◀ OVERTOP GEAR INSTALLATION

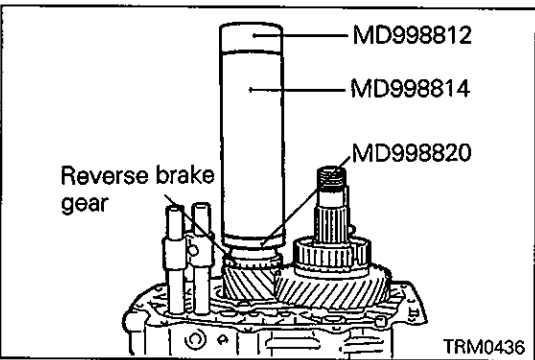

▶M◀ REVERSE BRAKE GEAR INSTALLATION

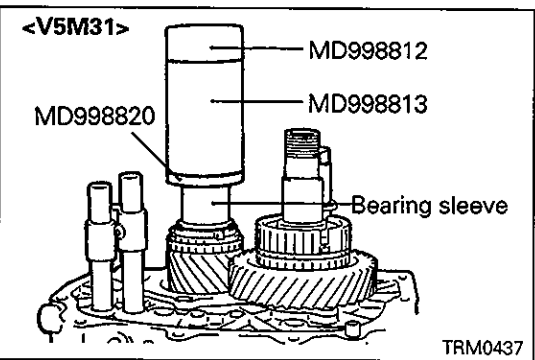

▶N◀ REVERSE GEAR BEARING SLEEVE INSTALLATION

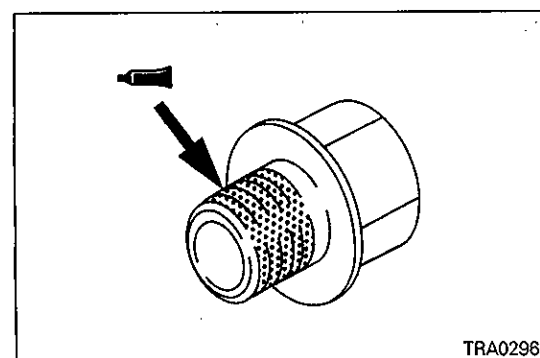
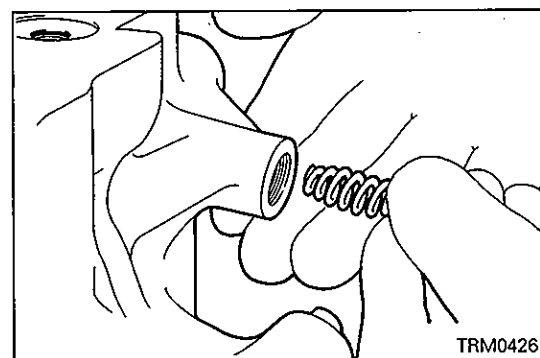
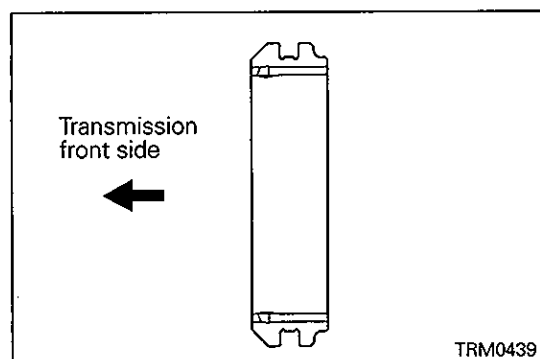
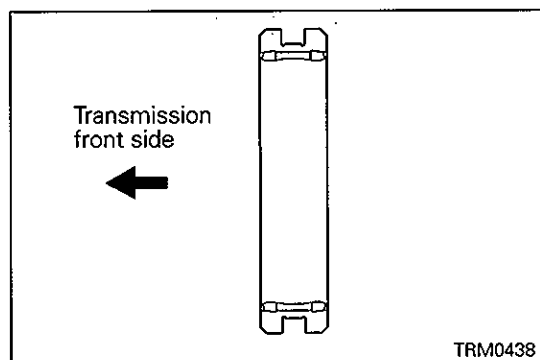
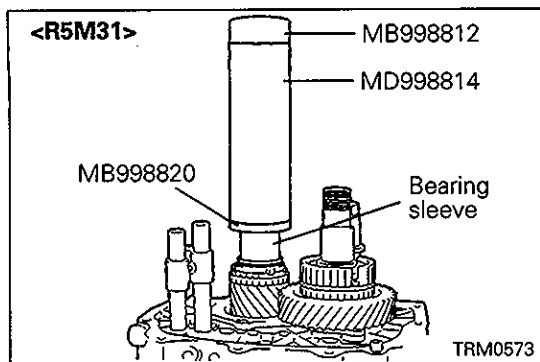

▶◀ 5TH SPEED SYNCHRONIZER SLEEVE INSTALLATION

▶◀ REVERSE SYNCHRONIZER SLEEVE INSTALLATION

▶◀ POPPET SPRING INSTALLATION

- (1) Install the poppet spring with the small end directed to the steel ball.

▶◀ POPPET PLUG INSTALLATION

- (1) The poppet plug is a precoated one. When it is to be reused, apply sealant to the plug beforehand.

Specified sealant:
3M ATD Part No. 8660 or equivalent

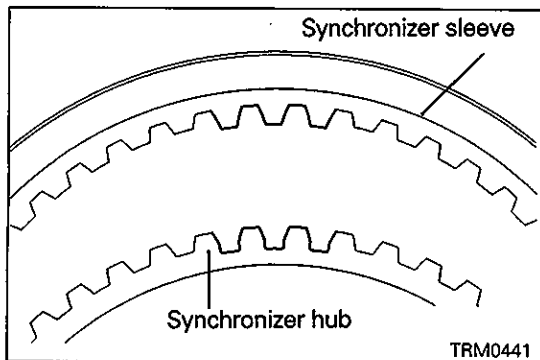

⇨S⇩ REVERSE GEAR INSTALLATION

- (1) Install the reverse gear while aligning the deep grooves in the synchronizer hub section with the projections on the sleeve inner periphery.

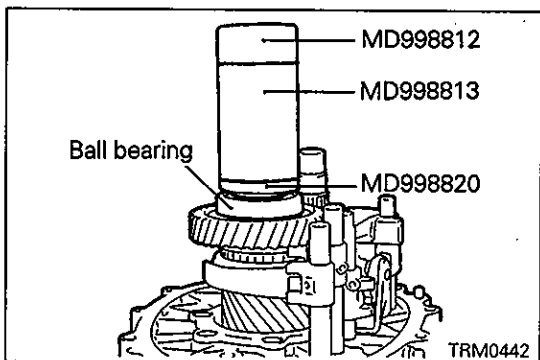

⇨T⇩ BALL BEARING INSTALLATION

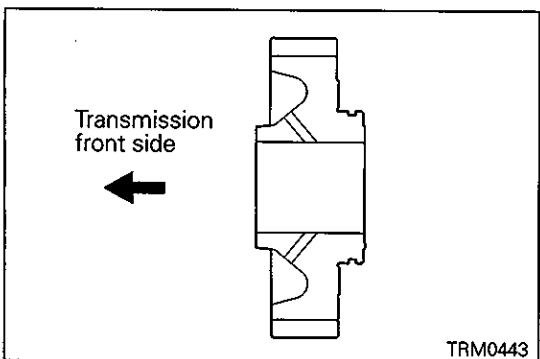

⇨U⇩ REVERSE IDLER GEAR INSTALLATION

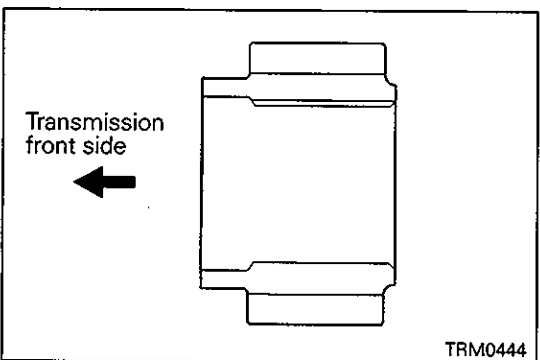

⇨V⇩ COUNTER REVERSE GEAR INSTALLATION

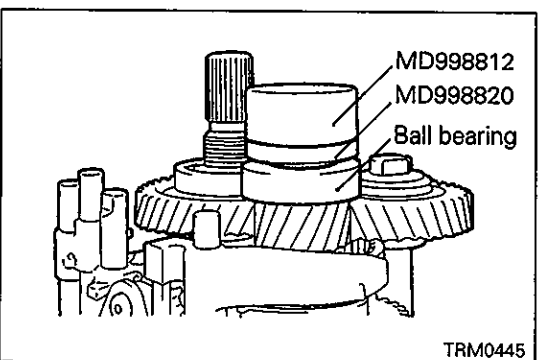

⇨W⇩ BALL BEARING INSTALLATION

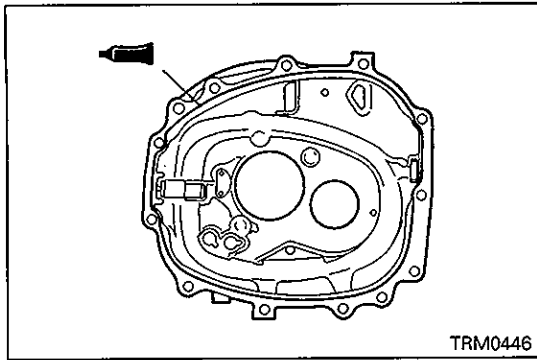

❖X❖ TRANSFER CASE ADAPTER INSTALLATION

- (1) Apply a bead of sealant to the transfer case adapter as illustrated.

Specified sealant:

Mitsubishi genuine sealant Part No. MD997740 or equivalent

Caution

- Squeeze sealant out evenly to make sure that it is not broken or excessively supplied.

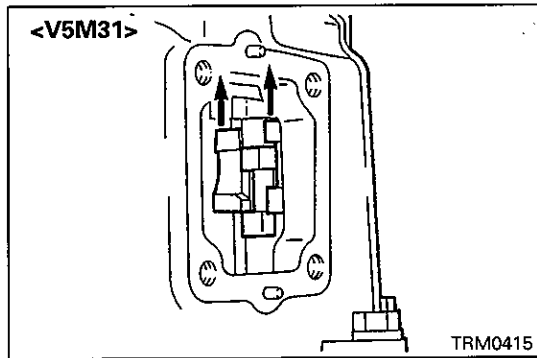

❖Y❖ LOCK NUT INSTALLATION

- (1) Slide the synchronizer sleeves as illustrated to put the two speed gears into engagement. <V5M31>

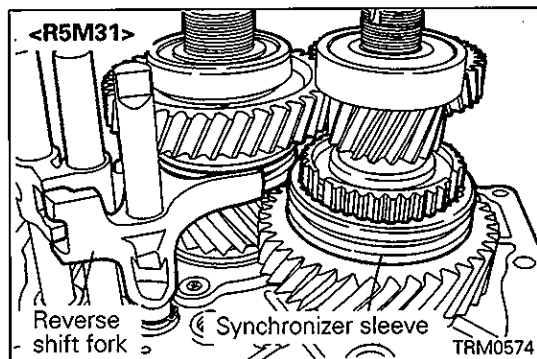

- (2) Shift the reverse shift fork and the 5th synchronizer sleeve as shown in the illustration to engage gears to fix the shaft. <R5M31>

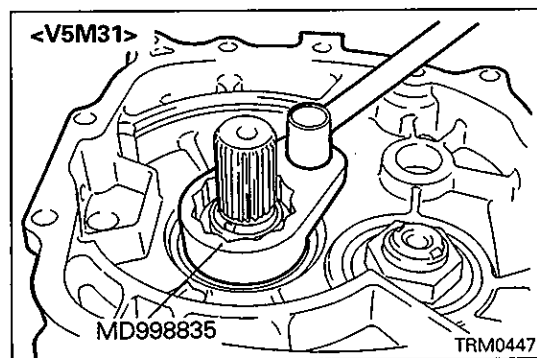

- (3) Using the special tool, tighten the main shaft lock nut to the specified torque.
- (4) Remove the lock nut and again tighten it to the specified torque.

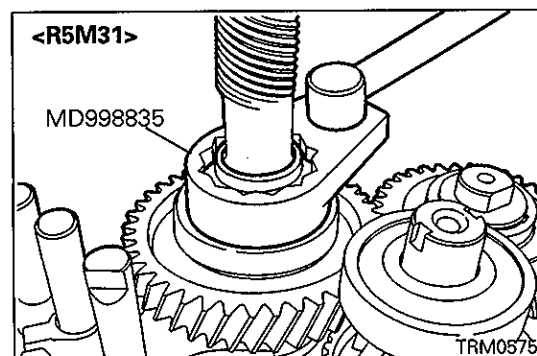

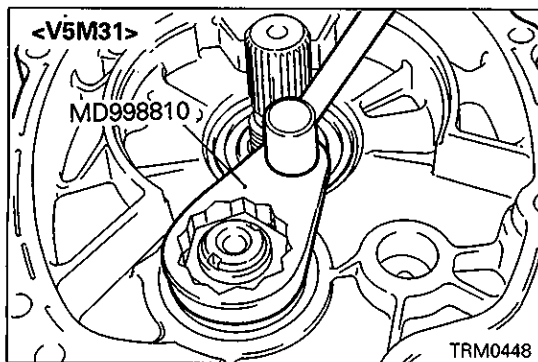

- (5) Using the special tool, tighten the countershaft cluster gear lock nut to the specified torque.
- (6) Remove the lock nut and again tighten it to the specified torque.

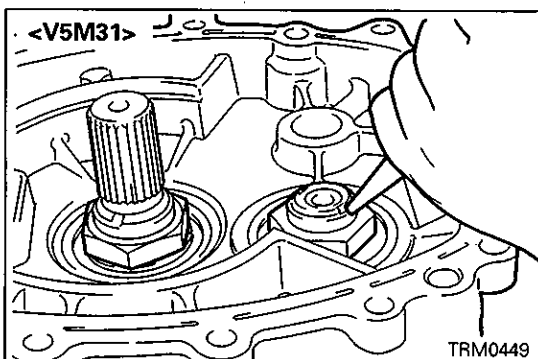
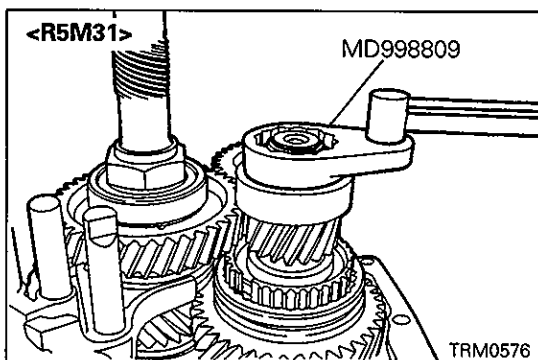

- (7) Stake the two lock nuts firmly using a punch or the like.

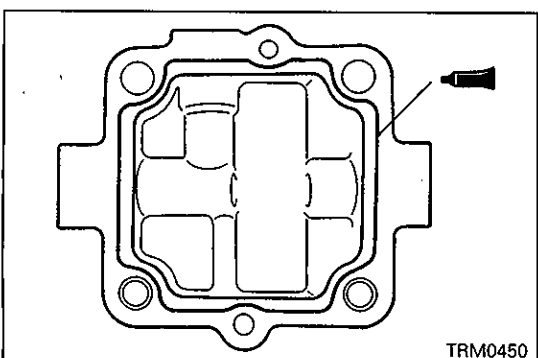
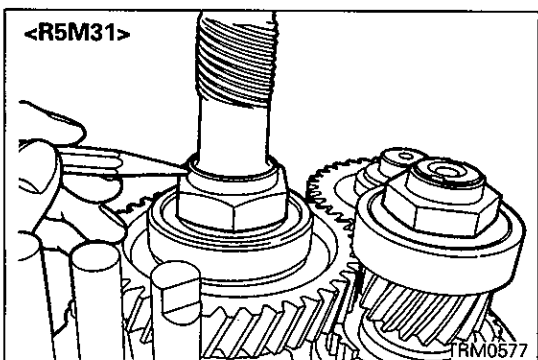

⇨Z⇩ UPPER COVER INSTALLATION

- (1) Apply a bead of sealant to the transfer case adapter as illustrated.

Specified sealant:

Mitsubishi genuine sealant Part No. MD997740 or equivalent

Caution

- Squeeze sealant out evenly to make sure that it is not broken or excessively supplied.

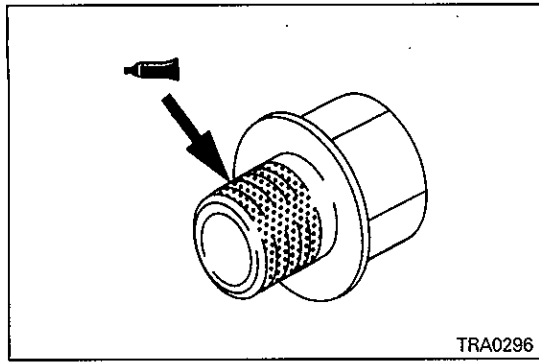

▶AA▶ NEUTRAL RETURN PLUNGER PLUG INSTALLATION

- (1) The plug is a precoated one. When it is to be reused, apply sealant beforehand.

Specified sealant:

Mitsubishi 3M ATD Part No. 8660 or equivalent

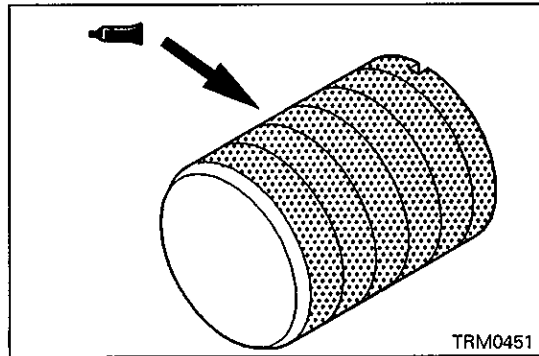

▶AB▶ RESISTANCE SPRING PLUG INSTALLATION

- (1) The plug is a precoated one. When it is to be reused, apply sealant beforehand.

Specified sealant:

Mitsubishi 3M ATD Part No. 8660 or equivalent

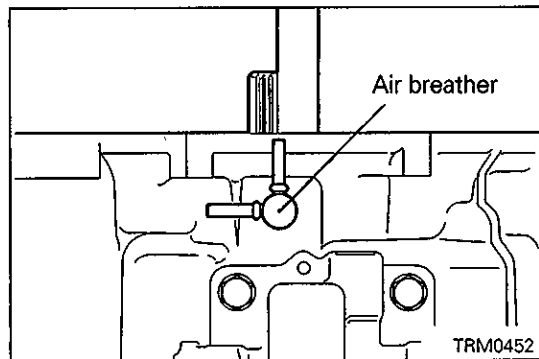

▶AC▶ AIR BREATHER INSTALLATION

- (1) Apply sealant to the air breather at the area which is inserted in transfer case adapter.

Specified sealant:

Mitsubishi genuine sealant Part No. MD997740 or equivalent

- (2) Install the air breather to the transfer case adapter as illustrated.

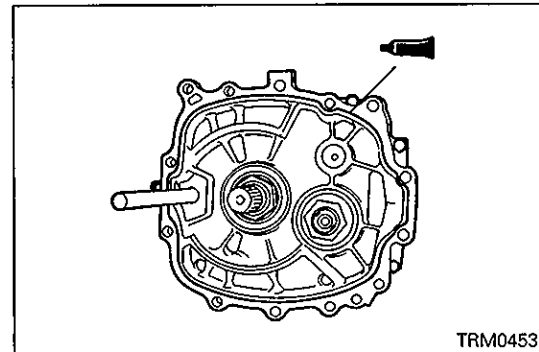

▶AD▶ TRANSFER INSTALLATION

- (1) Apply a bead of sealant to the transfer case adapter as illustrated.

Specified sealant:

Mitsubishi genuine sealant Part No. MD997740 or equivalent

Caution

- Squeeze sealant out evenly to make sure that it is not broken or excessively supplied.
- Do not forget to slide the change shifter over the control shaft.

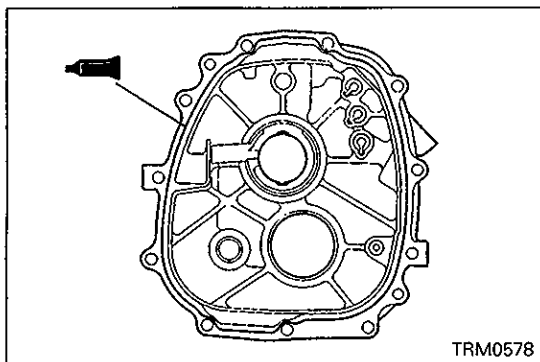

▶AE◀ EXTENSION HOUSING INSTALLATION

- (1) Apply sealant to the extension housing as shown in the illustration.

Specified sealant:

Mitsubishi genuine sealant Part No. MD997740 or equivalent

Caution

- Squeeze out the sealant evenly to make sure that it is not broken or excessively supplied.

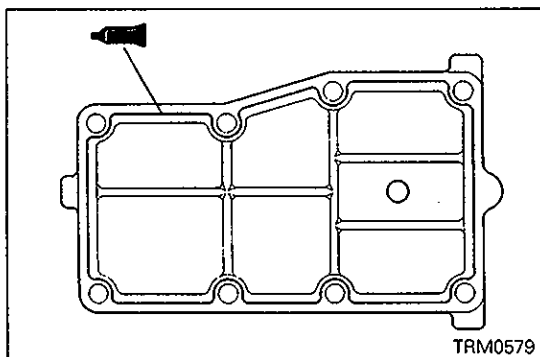

▶AF◀ EXTENSION HOUSING COVER INSTALLATION

- (1) Apply sealant to the extension housing cover as shown in the illustration.

Specified sealant:

Mitsubishi genuine sealant Part No. MD997740 or equivalent

Caution

- Squeeze out the sealant evenly to make sure that it is not broken or excessively supplied.

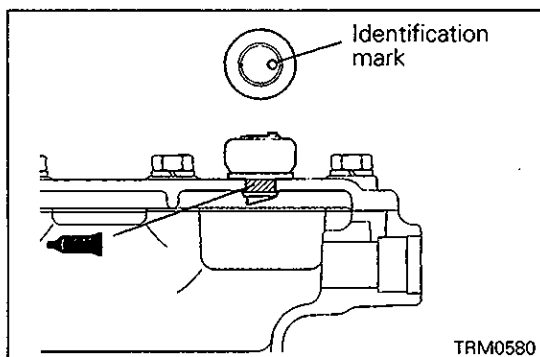

▶AG◀ AIR BREATHER INSTALLATION

- (1) Apply sealant as shown in the illustration and install the breather with its identification mark directed toward the rear of the transmission.

Specified sealant:

Mitsubishi genuine sealant Part No. MD997740 or equivalent

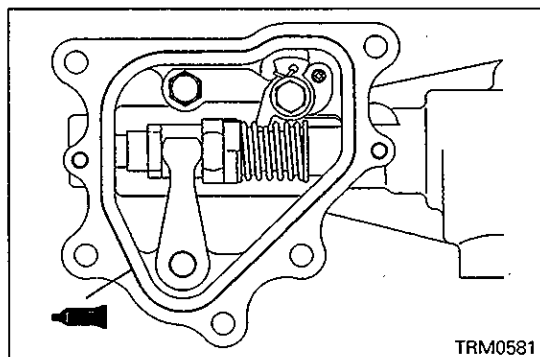

▶AH◀ CONTROL HOUSING INSTALLATION

- (1) Apply sealant to the control housing as shown in the illustration.

Specified sealant:

Mitsubishi genuine sealant Part No. MD997740 or equivalent

Caution

- Squeeze out the sealant evenly to make sure that it is not broken or excessively supplied.

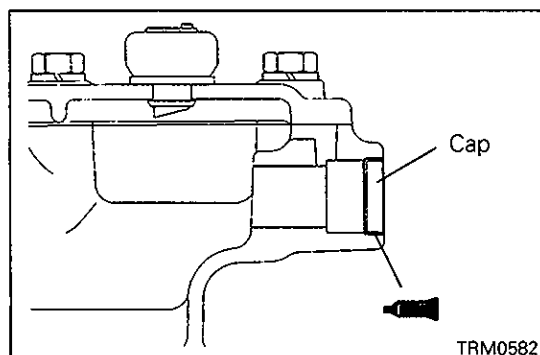

▶AI◀ CONTROL SHAFT CAP INSTALLATION

- (1) Apply sealant to the outer circumference of the control shaft cap and press in the cap until it becomes flat with the extension housing surface.

Specified sealant:

Mitsubishi genuine sealant Part No. MD997740 or equivalent

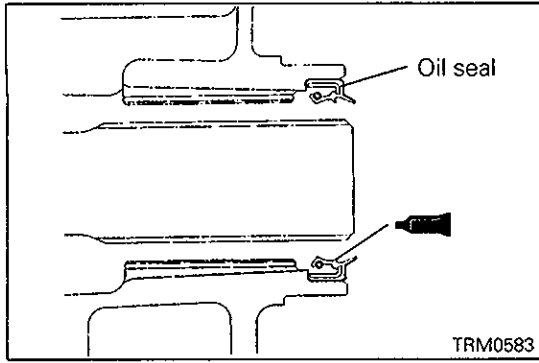

▶AJ◀ OIL SEAL INSTALLATION

- (1) After installation, pack grease between the lips of the oil seal.
Specified grease:
Mitsubishi genuine grease Part No. 0101011 or equivalent.

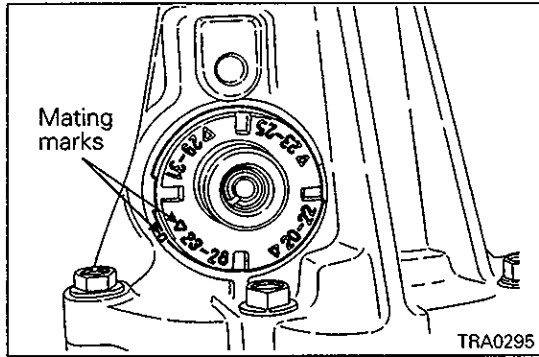

▶AK◀ SPEEDOMETER GEAR INSTALLATION

- (1) Match the mating marks to the number of teeth.

Caution

- The number marked on the sleeve is the number of teeth of the driven gear.

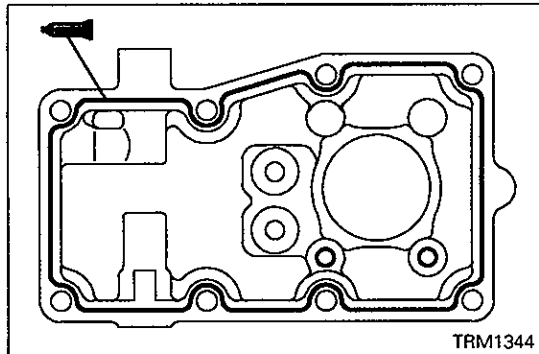

▶AL◀ CONTROL HOUSING INSTALLATION

- (1) Apply sealant to the control housing as shown in the illustration.

Specified sealant:

Mitsubishi genuine sealant Part No. MD997740 or equivalent

Caution

- Squeeze out the sealant evenly to make sure that it is not broken or excessively supplied.

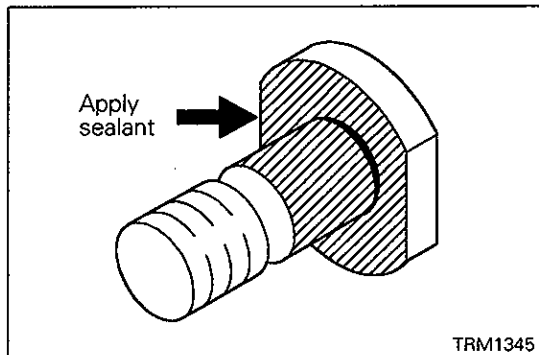

▶AM◀ SPECIAL BOLT INSTALLATION

- (1) Apply sealant to the special bolt as shown in the illustration.

Specified sealant:

3M ATD Part No. 8660 or equivalent

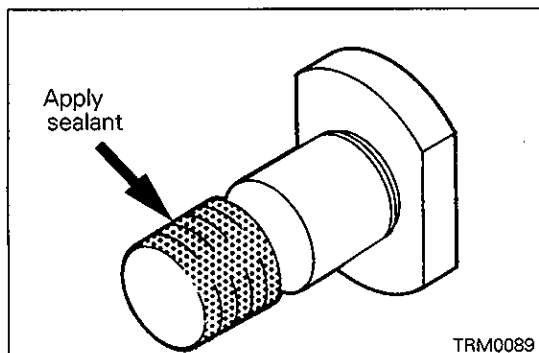

Specified sealant:

3M Scotch Grip No. 2353 or equivalent

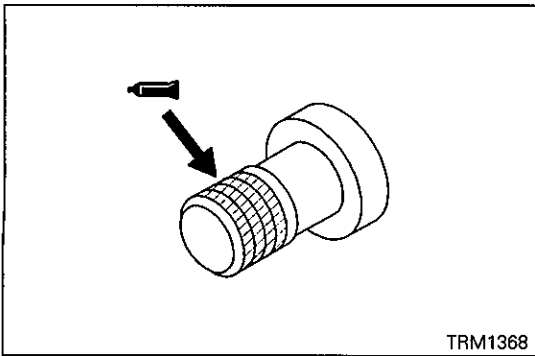

TRM1368

◆AN◆ POPPET PLUG "A" INSTALLATION

(1) The poppet plug "A" is a precoated one. When it is to be re-used, apply sealant to the plug beforehand.

Specified sealant:
3M ATD Part No. 8660 or equivalent

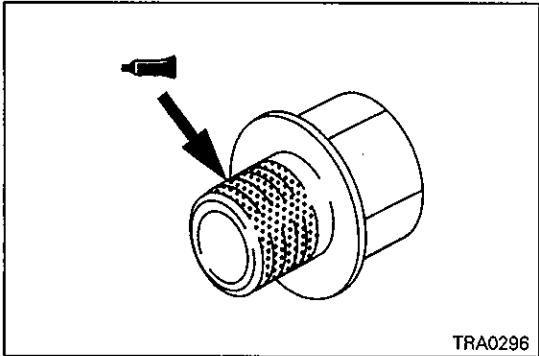

TRA0296

◆A0◆ SEAL BOLT INSTALLATION

(1) The seal bolt is a precoated one. When it is to be re-used, apply sealant to the bolt beforehand.

Specified sealant:
3M ATD Part No. 8660 or equivalent

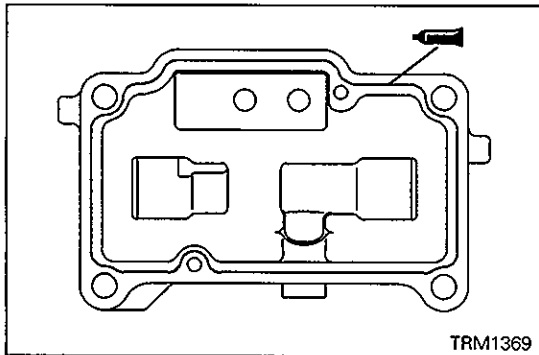

TRM1369

◆AP◆ UPPER COVER INSTALLATION

(1) Apply a bead of sealant to the upper cover as illustrated.

Specified sealant:
Mitsubishi genuine sealant Part No. MD997740 or equivalent

Caution

- Squeeze sealant out evenly to make sure that it is not broken or excessively supplied.

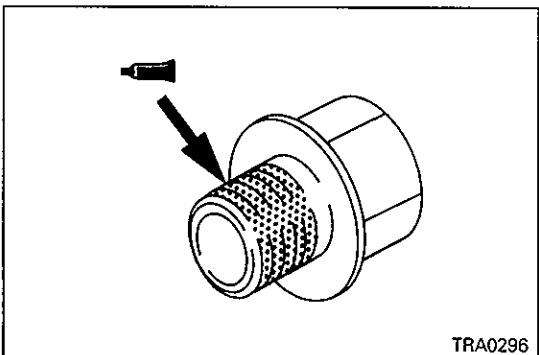

TRA0296

◆AQ◆ SEAL PLUG INSTALLATION

(1) The plug is a precoated one. When it is to be re-used, apply sealant beforehand.

Specified sealant:
3M ATD Part No. 8660 or equivalent

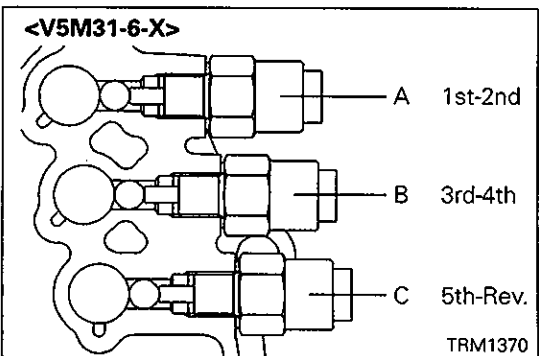

TRM1370

◆AR◆ BACKLIGHT SWITCH INSTALLATION <V5M31-6-X>

Switch	Ident. tape color
A	Red
B	Blue
C	White

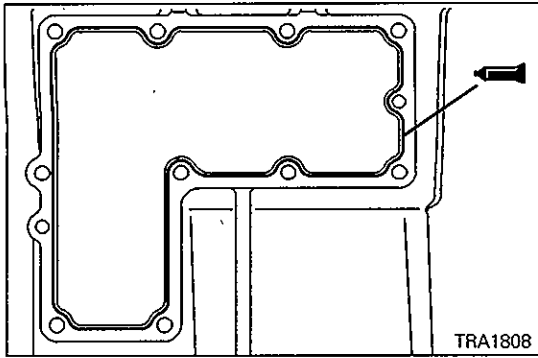

▶AS◀ CONTROL HOUSING INSTALLATION

(1) Apply sealant to the illustrated position of the control housing.

Specified sealant:

Mitsubishi genuine sealant Part No. MD997740 or equivalent

Caution

- Squeeze the sealant out evenly to make sure that it is not broken or excessively supplied.

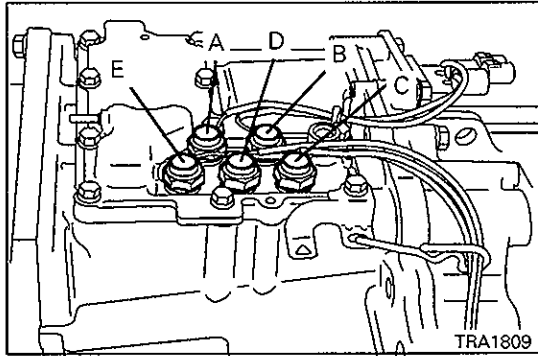

▶AT◀ SWITCHES INSTALLATION

(1) Install the switches in the right positions.

Mounting Position	Switch Name	Tube Color	Connector Color
A	4LLC switch	Black	Brown
B	2WD switch	Black	Black
C	Center differential lock switch	Blue	Brown
D	4H switch	Blue	White
E	2WD-4WD switch	Blue	Black

4. MAIN DRIVE PINION DISASSEMBLY AND REASSEMBLY

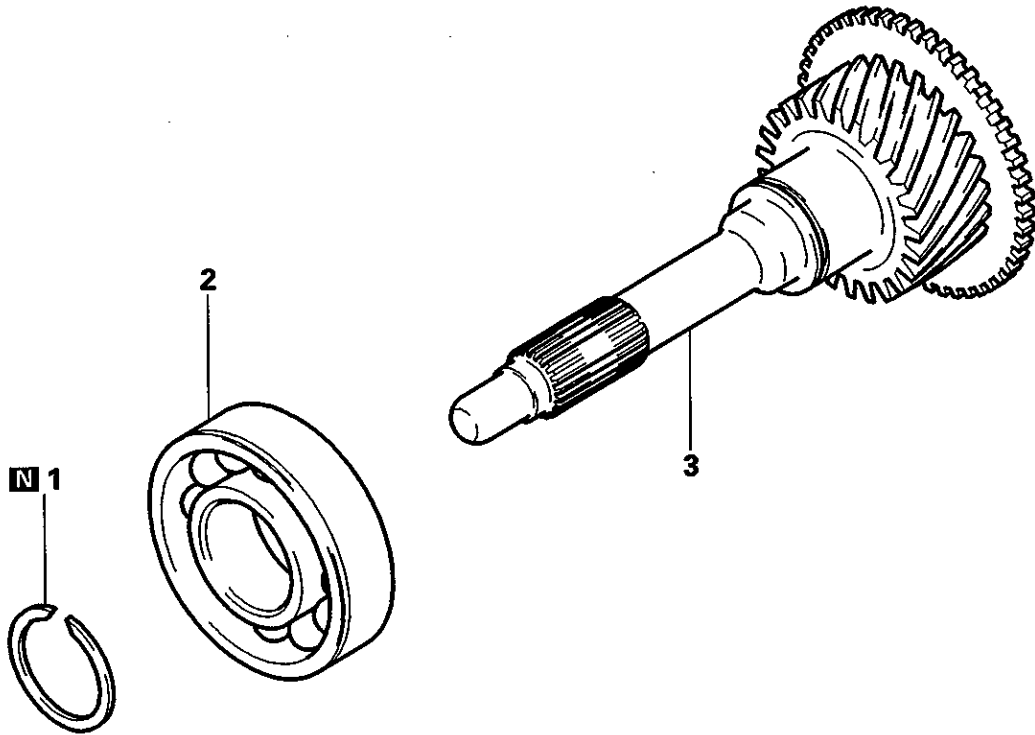

Disassembly steps

- ▶B◀ 1. Snap ring
- ◀A▶▶A◀ 2. Ball bearing
- 3. Main drive pinion

 Lubricate all internal parts with gear oil during reassembly.

TRM0511

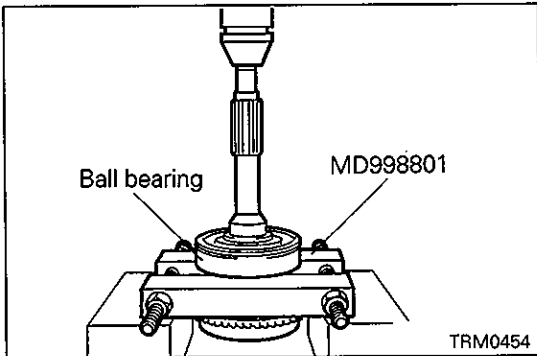

DISASSEMBLY SERVICE POINT

◀A▶ **BALL BEARING REMOVAL**

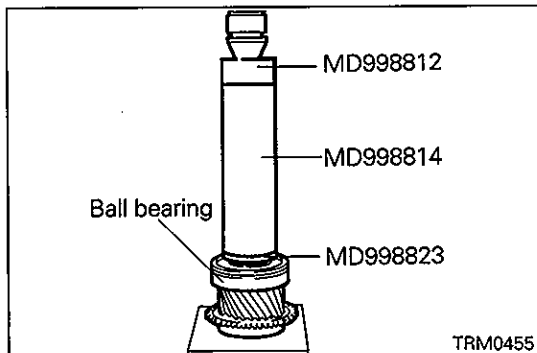

REASSEMBLY SERVICE POINTS

▶A◀ **BALL BEARING INSTALLATION**

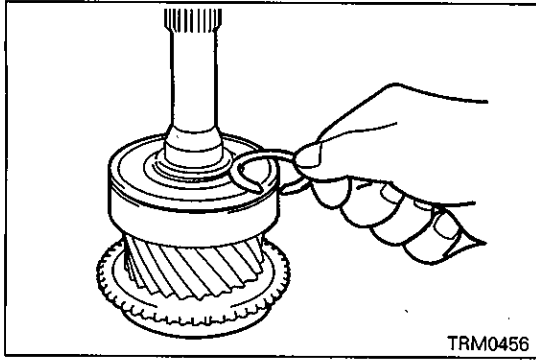
**▶B◀ SNAP RING INSTALLATION**

- (1) Select a snap ring which will make the main drive pinion bearing end play equal to the standard value:

Standard value: 0 – 0.06 mm (0 – 0.0024 in.)

5. COUNTERSHAFT CLUSTER GEAR

DISASSEMBLY AND REASSEMBLY

Apply gear oil to all moving parts before installation.

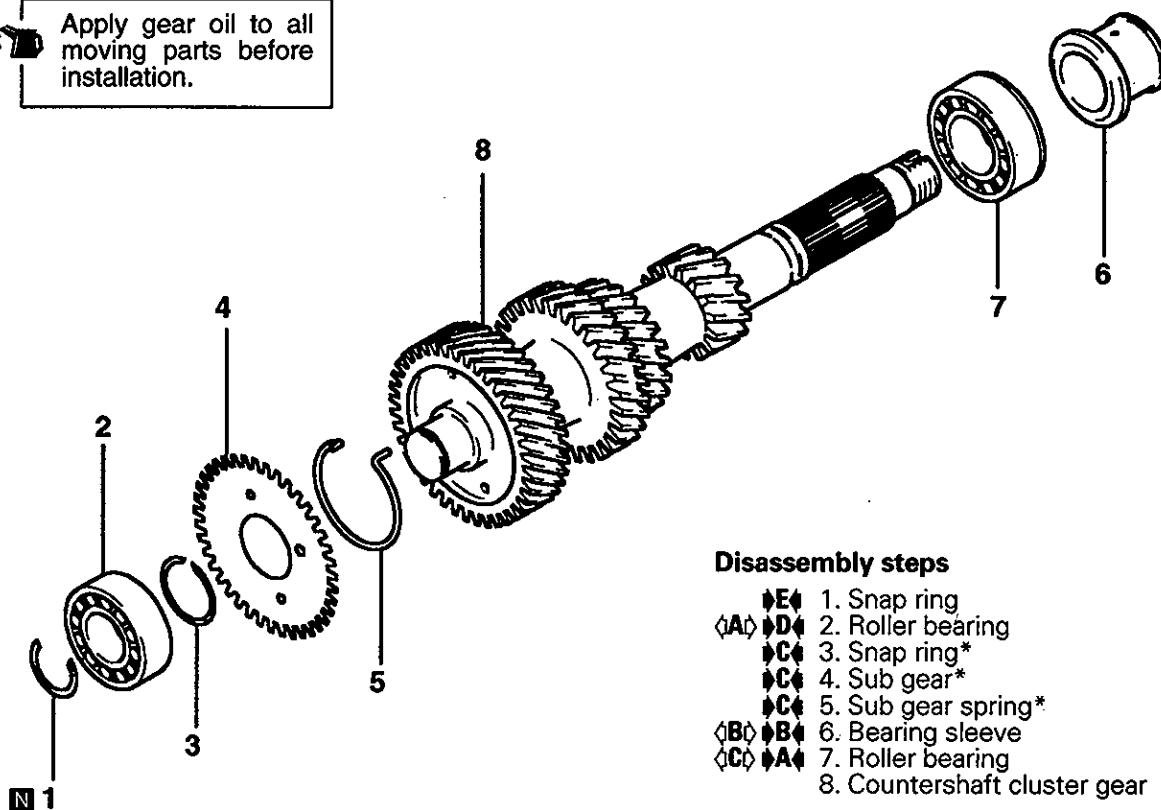

Disassembly steps

- ◆E◆ 1. Snap ring
- ◊A◆ ◆D◆ 2. Roller bearing
- ◆C◆ 3. Snap ring*
- ◆C◆ 4. Sub gear*
- ◆C◆ 5. Sub gear spring*
- ◊B◆ ◆B◆ 6. Bearing sleeve
- ◊C◆ ◆A◆ 7. Roller bearing
- 8. Countershaft cluster gear

NOTE:
*: Not provided on some model.

TRM0512

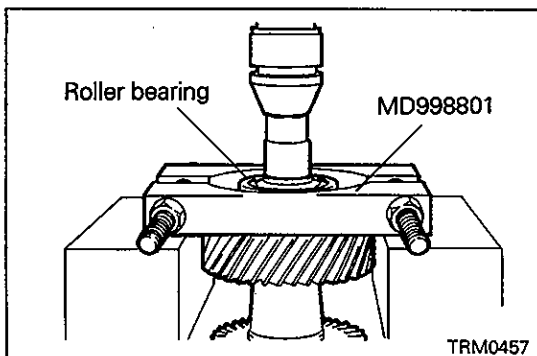

DISASSEMBLY SERVICE POINTS

◊A◆ ROLLER BEARING REMOVAL

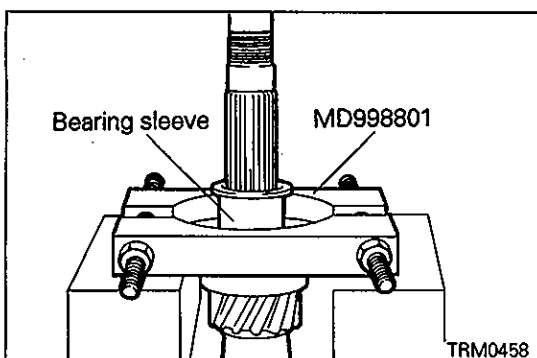

◊B◆ BEARING SLEEVE REMOVAL

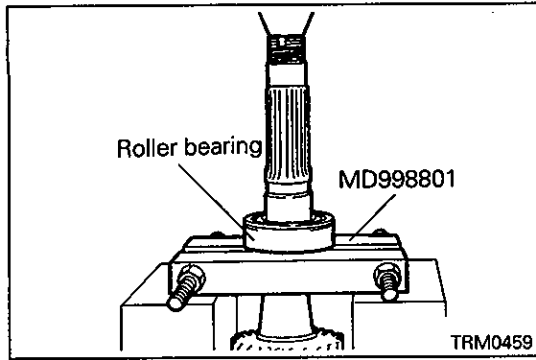

⇄ ROLLER BEARING REMOVAL

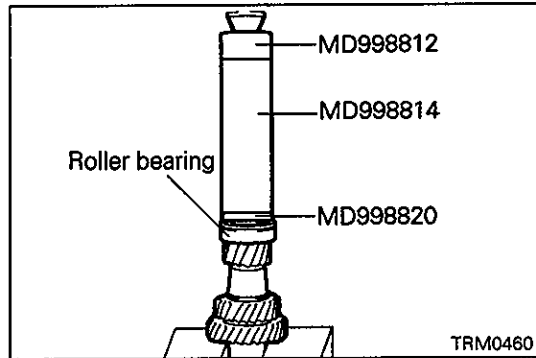

REASSEMBLY SERVICE POINTS

⇄ ROLLER BEARING INSTALLATION

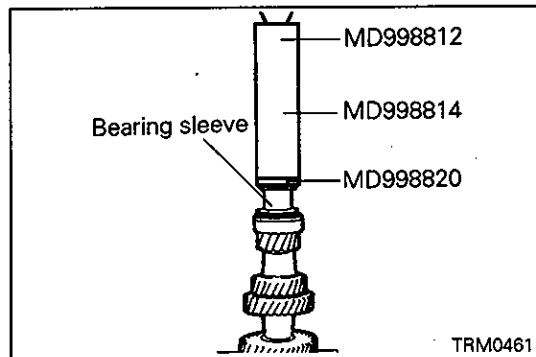

⇄ BEARING SLEEVE INSTALLATION

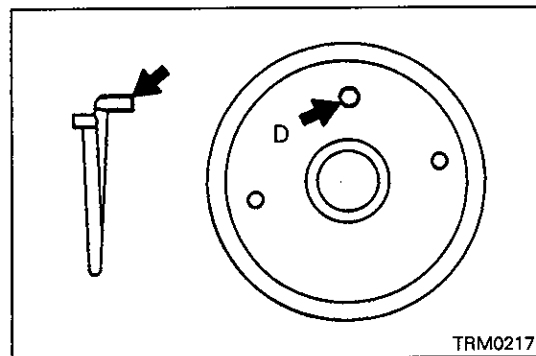

⇄ SUB GEAR SPRING / SUB GEAR / SNAP RING INSTALLATION

(1) Insert the long leg of the spring in the hole D in the countershaft cluster gear.

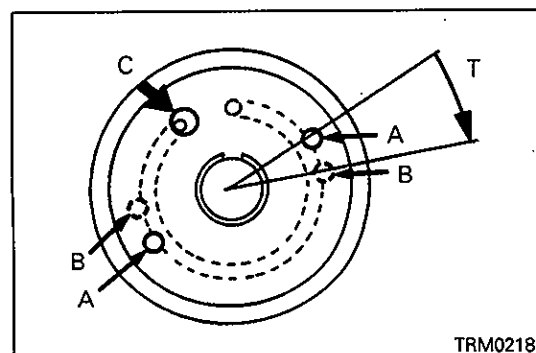

- (2) Fit the sub gear on the countershaft cluster gear while inserting the short leg of the spring in the hole C in the sub gear.
- (3) Install the snap ring.
- (4) Turn the sub gear clockwise (T) until the hole A in the sub gear is aligned with the hole B in the countershaft cluster gear.

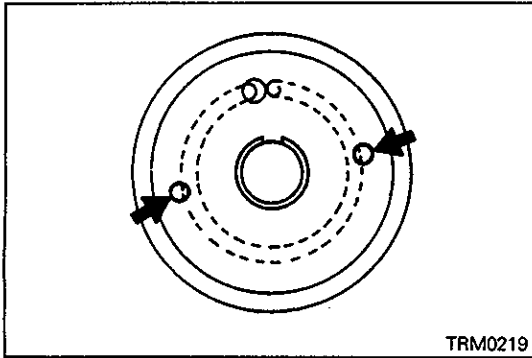

- (5) Insert a bolt ($\phi 5 \times 50$ mm) in the aligned holes A and B.
- (6) Keep the bolt attached until the countershaft cluster gear has been assembled in the transmission case.

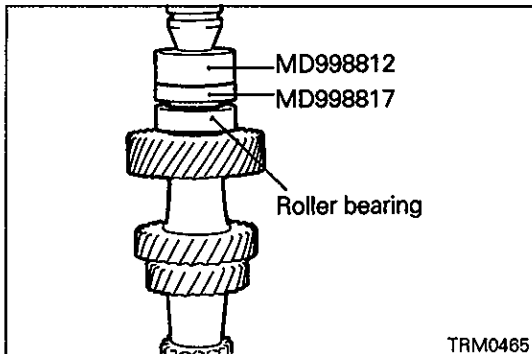

⇨⇩ ROLLER BEARING INSTALLATION

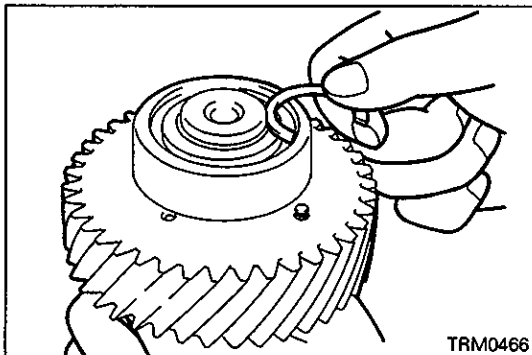

⇨⇩ SNAP RING INSTALLATION

- (1) Select a snap ring which will make the countershaft cluster gear bearing end play equal to the standard value:

Standard value: 0 – 0.15 mm (0 – 0.0059 in.)

NOTES

6. MAIN SHAFT

DISASSEMBLY AND REASSEMBLY

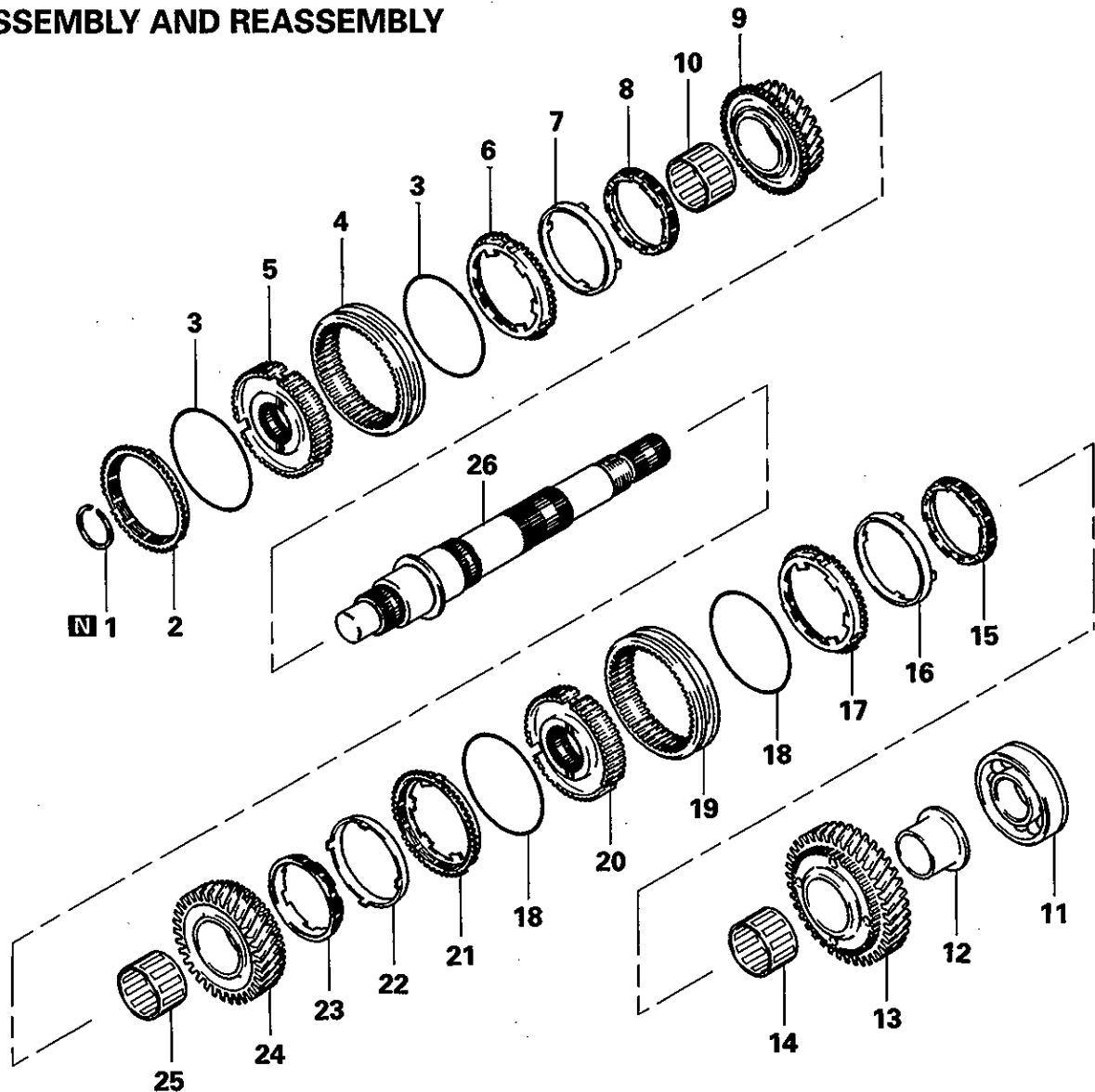

 Lubricate all internal parts with gear oil during reassembly.

Disassembly steps

- | | | |
|--------|--------------------------------------|--|
| ▶I▶ | 1. Snap ring | 14. Needle bearing |
| | 2. Synchronizer ring | ▶A▶15. Synchronizer inner ring |
| ▶H▶ | 3. Synchronizer spring | ▶A▶16. Synchronizer cone |
| ▶D▶ | 4. 3rd-4th speed synchronizer sleeve | ▶A▶17. Synchronizer outer ring |
| ◊A◊▶G▶ | 5. 3rd-4th speed synchronizer hub | ▶D▶18. Synchronizer spring |
| ▶A▶ | 6. Synchronizer outer ring | ▶C▶19. 1st-2nd speed synchronizer sleeve |
| ▶A▶ | 7. Synchronizer cone | ◊C◊▶B▶20. 1st-2nd speed synchronizer hub |
| ▶A▶ | 8. Synchronizer inner ring | ▶A▶21. Synchronizer outer ring |
| | 9. 3rd speed gear | ▶A▶22. Synchronizer cone |
| ◊B◊▶F▶ | 10. Needle bearing | ▶A▶23. Synchronizer inner ring |
| ◊B◊▶E▶ | 11. Ball bearing | 24. 2nd speed gear |
| | 12. Bearing sleeve | 25. Needle bearing |
| | 13. 1st speed gear | 26. Main shaft |

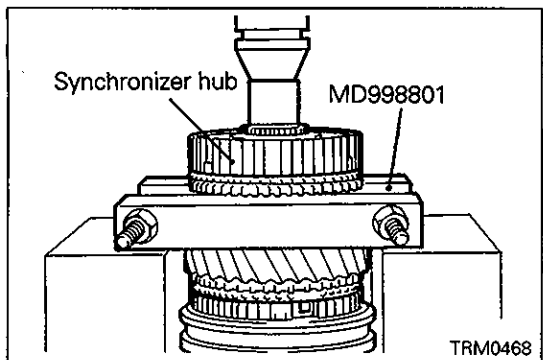
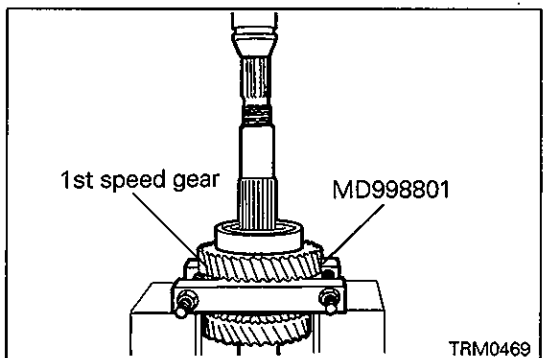
**DISASSEMBLY SERVICE POINTS****◁A▷ 3RD-4TH SPEED SYNCHRONIZER HUB REMOVAL****◁B▷ BALL BEARING / BEARING SLEEVE REMOVAL**

- (1) Support the 1st speed gear with the special tool to remove the ball bearing and bearing sleeve.

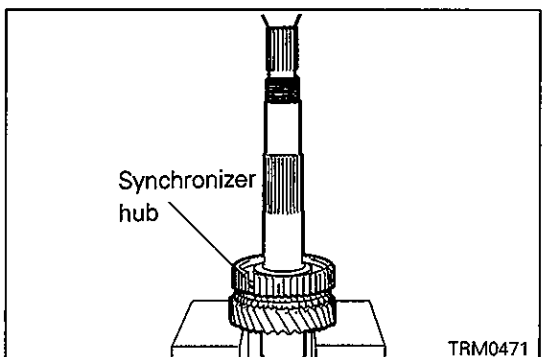
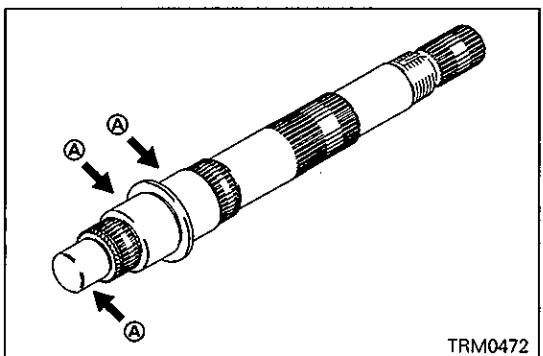
**◁C▷ 1ST-2ND SPEED SYNCHRONIZER HUB REMOVAL****INSPECTION****MAIN SHAFT**

- (1) Check the needle bearing mounting surface (area A) for damage, abnormal wear and seizure.
- (2) Check the spline for damage and wear.

NEEDLE BEARING

- (1) Check that the needle bearing, combined with the shaft or the bearing sleeve and gear, can rotate smoothly without abnormal sound.
- (2) Check that the cage is not deformed.

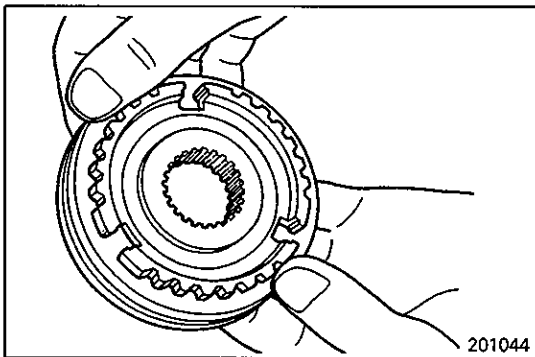
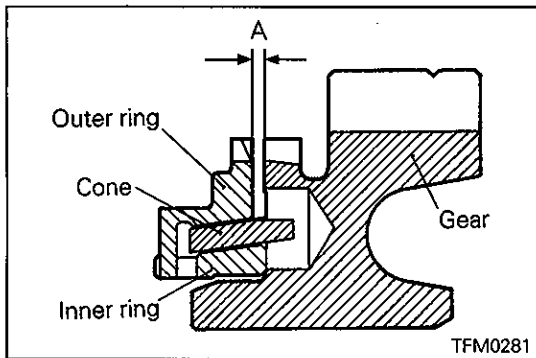
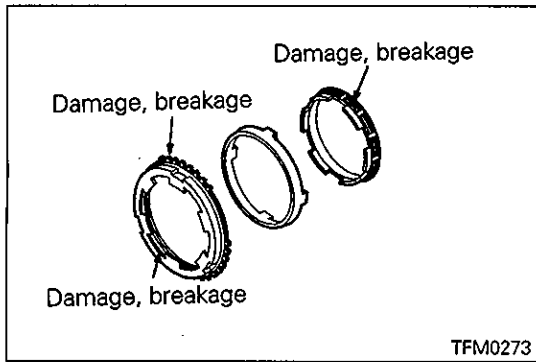

SYNCHRONIZER OUTER RING, INNER RING AND CONE

(1) Check the clutch gear teeth and cone surface for damage.

(2) Assemble the outer ring, inner ring and cone. Push them onto the speed gear and measure the clearance "A". If "A" is less than the limit, replace them.

Limit: 0.3 mm (0.012 in.)

Caution

- The outer ring, inner ring and cone must be replaced together as a set if necessary.

SYNCHRONIZER SLEEVE AND HUB

(1) Combine the synchronizer sleeve and hub and check that they can slide smoothly.

(2) Check that the front and rear inner ends of the sleeve are not damaged.

Caution

- Replace the synchronizer sleeve and hub together as a set if replacement is necessary.

SYNCHRONIZER SPRING

(1) Check that the spring is free from elasticity deterioration, deformation and fracture.

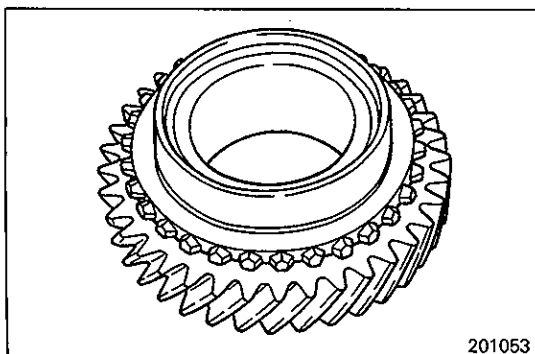

SPEED GEARS

(1) Check that the tooth flanks of the spiral gear and clutch gear are free from damage and wear.

(2) Check that the surface of the synchronizer cone is free from roughness, damage and wear.

(3) Check that the inner, front and rear surfaces are free from damage and wear.

REASSEMBLY SERVICE POINTS**▶A◀ SYNCHRONIZER INNER RING / CONE / OUTER RING INSTALLATION**

- (1) Assemble the inner ring, outer ring and cone and set the assembly to the synchronizer hub.

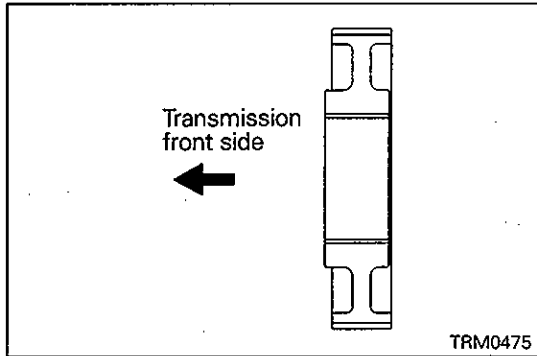
**▶B◀ 1ST-2ND SPEED SYNCHRONIZER HUB INSTALLATION**

- (1) Install the hub in the proper direction as illustrated.

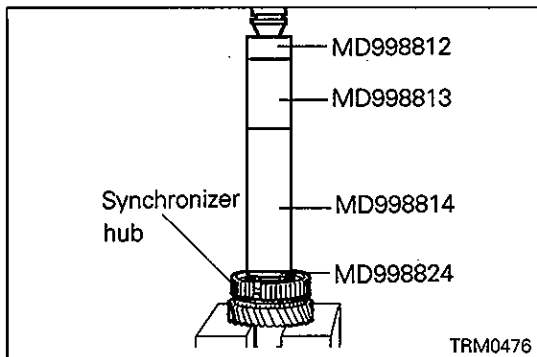
**▶C◀ 1ST-2ND SYNCHRONIZER SLEEVE INSTALLATION**

- (1) Install the sleeve with its projections aligned with the deep grooves in the synchronizer hub.

NOTE

The synchronizer sleeve can be installed in either direction.

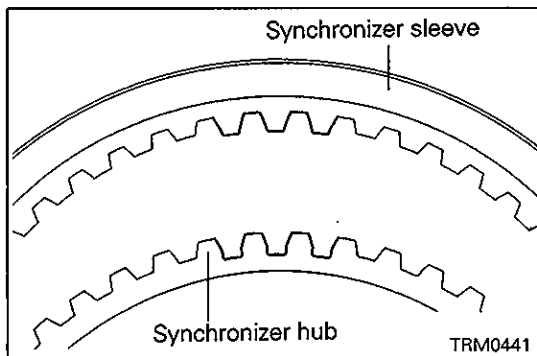
**▶D◀ SYNCHRONIZER SPRING INSTALLATION**

- (1) Install the synchronizer spring onto the synchronizer ring so that the spring is settled as illustrated.

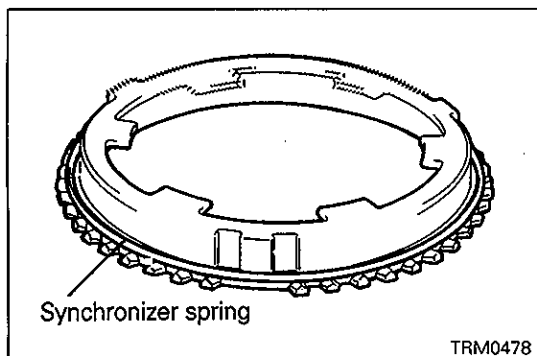

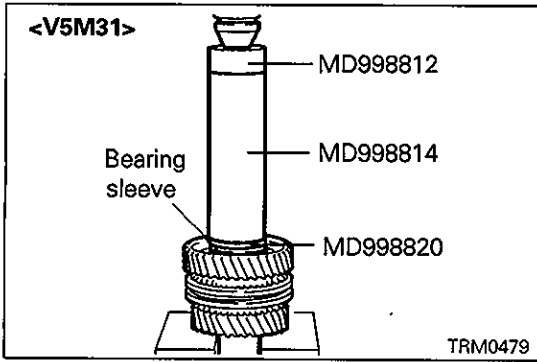

⇨E⇩ BEARING SLEEVE INSTALLATION

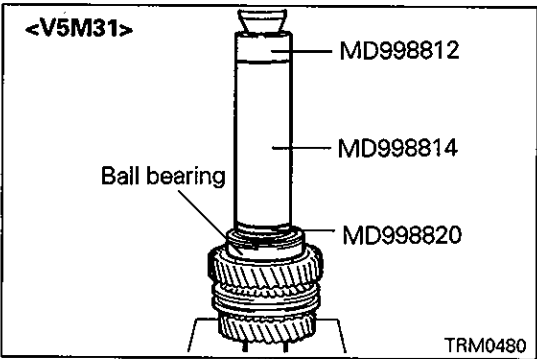
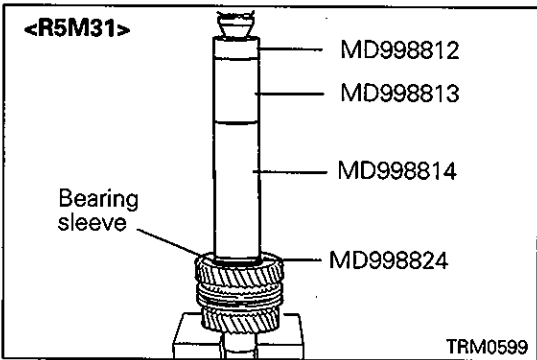

⇨F⇩ BALL BEARING INSTALLATION

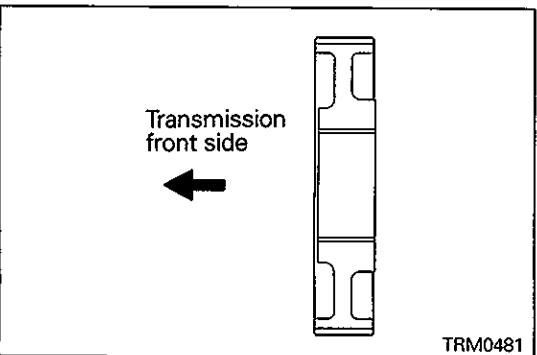
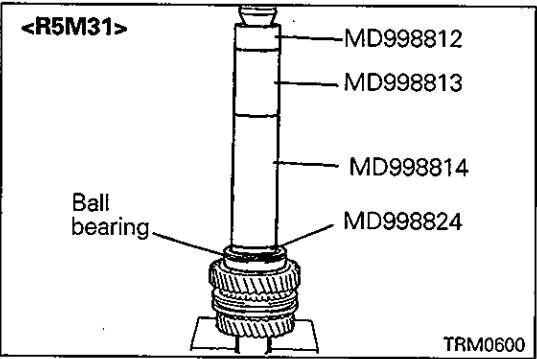

⇨G⇩ 3RD-4TH SYNCHRONIZER HUB INSTALLATION

(1) Install the hub in the proper direction as illustrated.

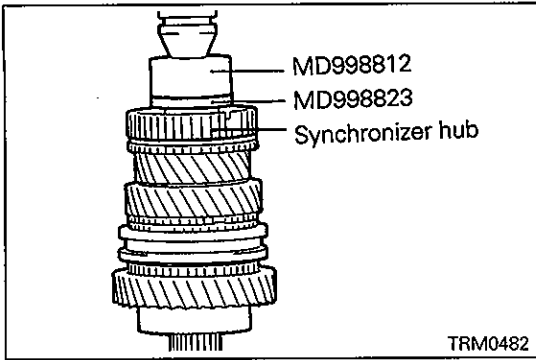

▶◀ 3RD-4TH SYNCHRONIZER SLEEVE INSTALLATION

- (1) Install the sleeve in the proper direction as illustrated.

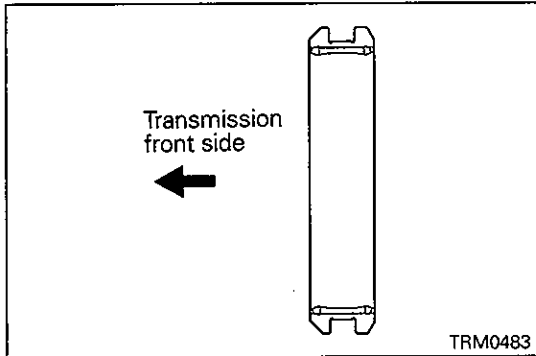

- (2) When installing the sleeve, align its projections with the deep grooves in the synchronizer hub.

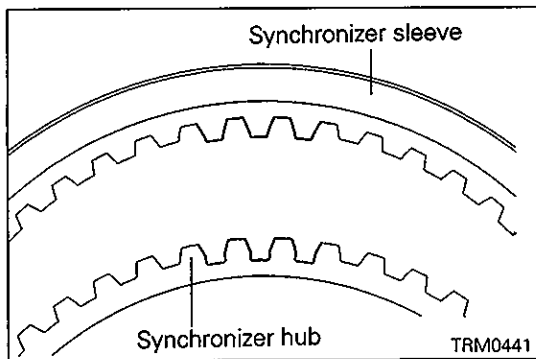

▶◀ SNAP RING INSTALLATION

- (1) Select a snap ring which will make the end play of the 3rd-4th synchronizer hub equal to the standard value:

Standard value: 0 – 0.08 mm (0 – 0.0031 in.)

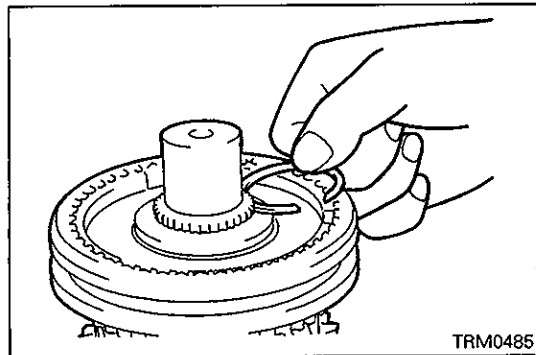

7. TRANSFER <V5M31>

DISASSEMBLY AND REASSEMBLY

<SUPER SELECT 4WD RHD>

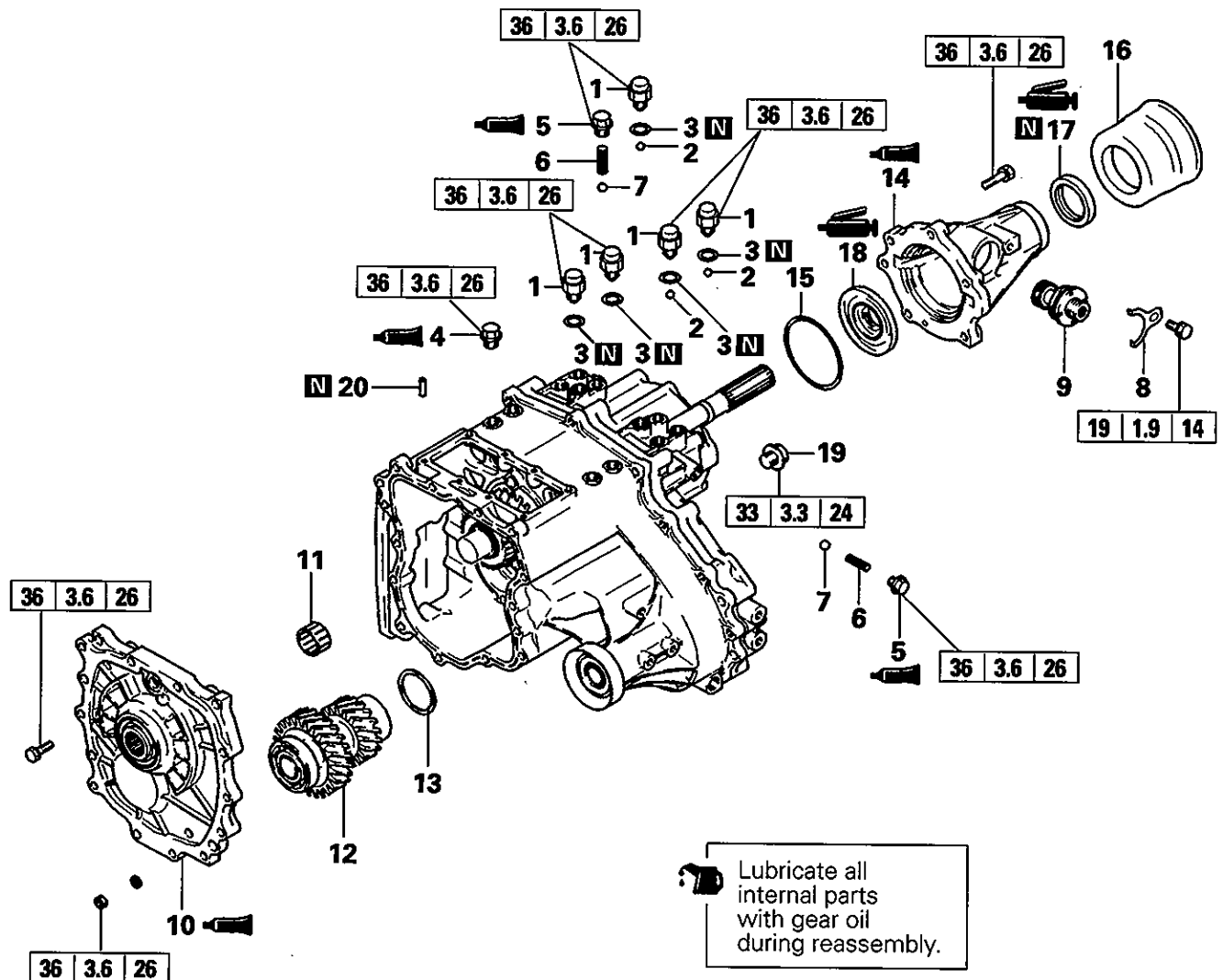

Disassembly steps

- | | |
|---|--|
| <p>↻W↻ 1. Detection switch</p> <p>↻V↻ 4. Plug</p> <p>↻U↻ 5. Poppet plug</p> <p>↻T↻ 6. Poppet spring</p> <p>↻S↻ 9. Speedometer gear</p> <p>↻R↻ 10. Transfer case plate</p> | <p>11. Needle bearing</p> <p>↻Q↻ 13. Spacer</p> <p>↻P↻ 14. Rear cover</p> <p>↻O↻ 15. Spacer</p> <p>↻N↻ 17. Oil seal</p> <p>↻M↻ 18. Oil seal</p> <p>↻L↻ 20. Spring pin (H-L shift fork)</p> |
| <p>2. Steel ball</p> <p>3. Gasket</p> <p>7. Steel ball</p> <p>8. Sleeve clamp</p> | <p>12. Countershaft gear</p> <p>13. Spacer</p> <p>14. Rear cover</p> <p>15. Spacer</p> <p>16. Dust seal guard</p> <p>19. H-L shift rail plug</p> |

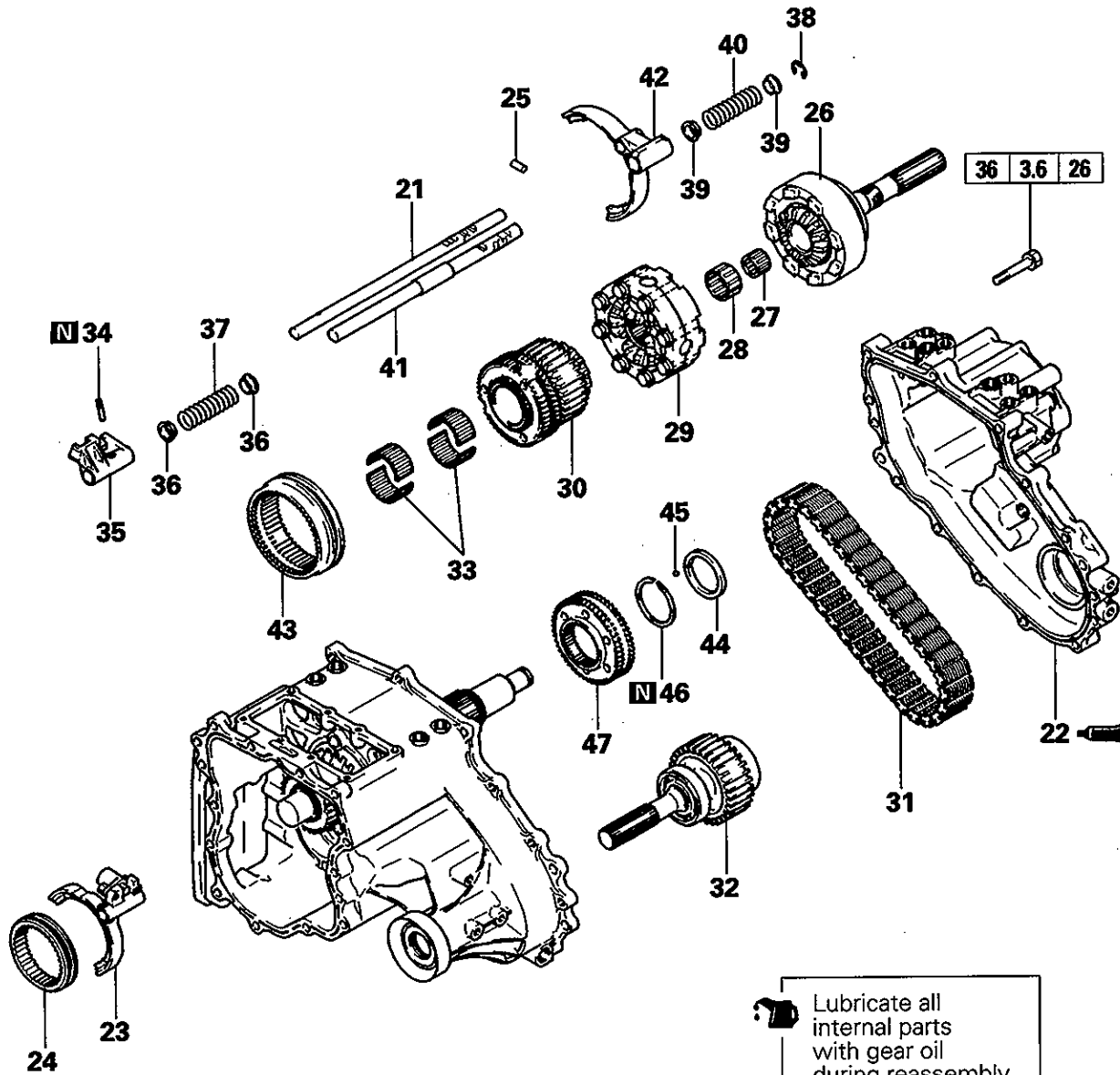

Disassembly steps

- | | |
|---|--|
| <p> $\diamond A \diamond L$ 21. H-L shift rail
 $\diamond A \diamond K$ 22. Chain cover
 23. H-L shift fork
 24. H-L clutch sleeve
 $\blacktriangleright K$ 25. Interlock plunger
 26. Rear output shaft
 27. Needle bearing
 28. Needle bearing
 29. Center differential case
 $\diamond B \diamond H$ 30. 2-4WD synchronizer
 $\diamond B \diamond H$ 31. Chain
 $\diamond B \diamond H$ 32. Front output shaft
 33. Needle bearing
 $\diamond C \diamond G$ 34. Spring pin (2-4WD shift lug) </p> | <p> $\blacktriangleright G \blacktriangleright$ 35. 2-4WD shift lug
 $\blacktriangleright G \blacktriangleright$ 36. Spring seat
 $\blacktriangleright G \blacktriangleright$ 37. Spring
 38. E-ring
 39. Spring seat
 40. Spring
 $\blacktriangleright G \blacktriangleright$ 41. 2-4WD shift rail
 42. 2-4WD shift fork
 43. 2-4WD synchronizer sleeve
 44. Sleeve
 45. Steel ball
 $\blacktriangleright F \blacktriangleright$ 46. Snap ring
 47. Differential lock hub </p> |
|---|--|

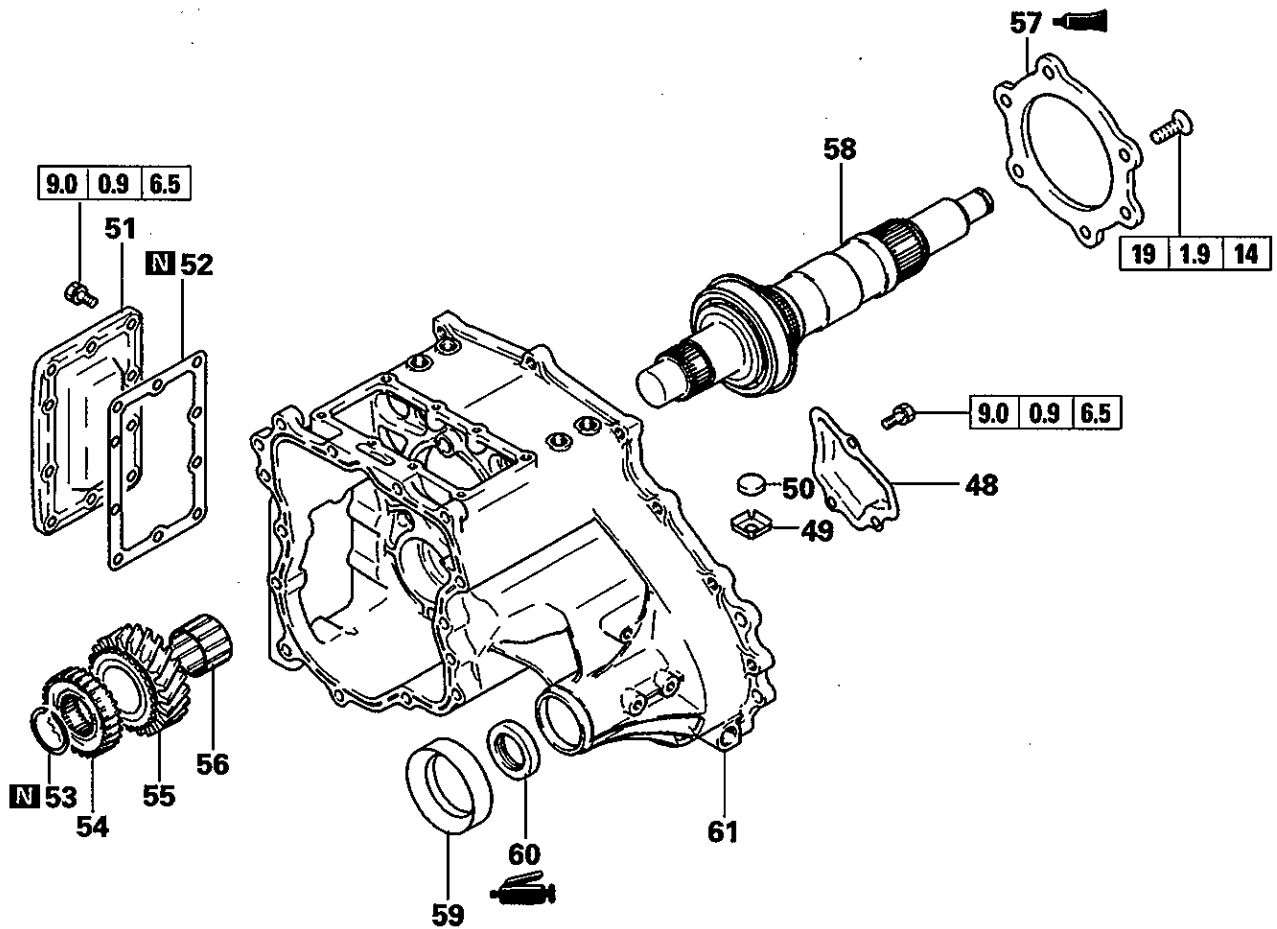

 Lubricate all internal parts with gear oil during reassembly.

Disassembly steps

- 48. Oil pool cover
- ▶E 49. Magnet holder
- ▶E 50. Magnet
- 51. Side cover
- 52. Side cover gasket
- ▶D 53. Snap ring
- ▶C 54. H-L clutch hub
- 55. Low speed gear
- 56. Needle bearing
- ▶B 57. Rear bearing retainer
- 58. Transfer drive shaft
- 59. Dust seal guard
- ▶A 60. Oil seal
- 61. Transfer case

DISASSEMBLY AND REASSEMBLY

<SUPER SELECT 4WD LHD>

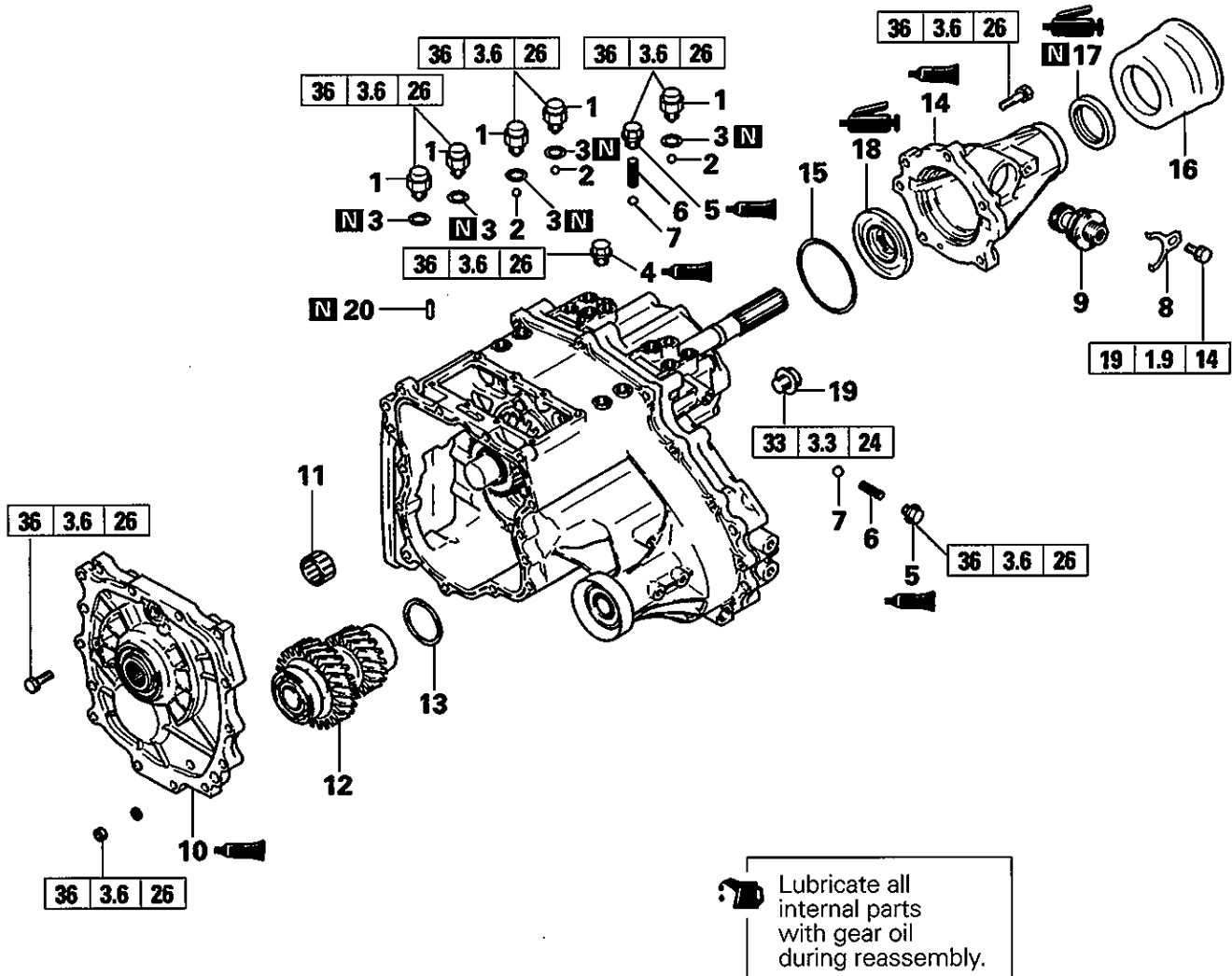

Disassembly steps

- | | | |
|-----|-------------------------|------------------------|
| ▶W▶ | 1. Detection switch | 11. Needle bearing |
| | 2. Steel ball | 12. Counter shaft gear |
| | 3. Gasket | ▶Q▶ |
| ▶V▶ | 4. Plug | ▶P▶ |
| ▶U▶ | 5. Poppet plug | ▶O▶ |
| ▶T▶ | 6. Poppet spring | ▶N▶ |
| | 7. Steel ball | ▶M▶ |
| | 8. Sleeve clamp | ▶L▶ |
| ▶S▶ | 9. Speedometer gear | |
| ▶R▶ | 10. Transfer case plate | |

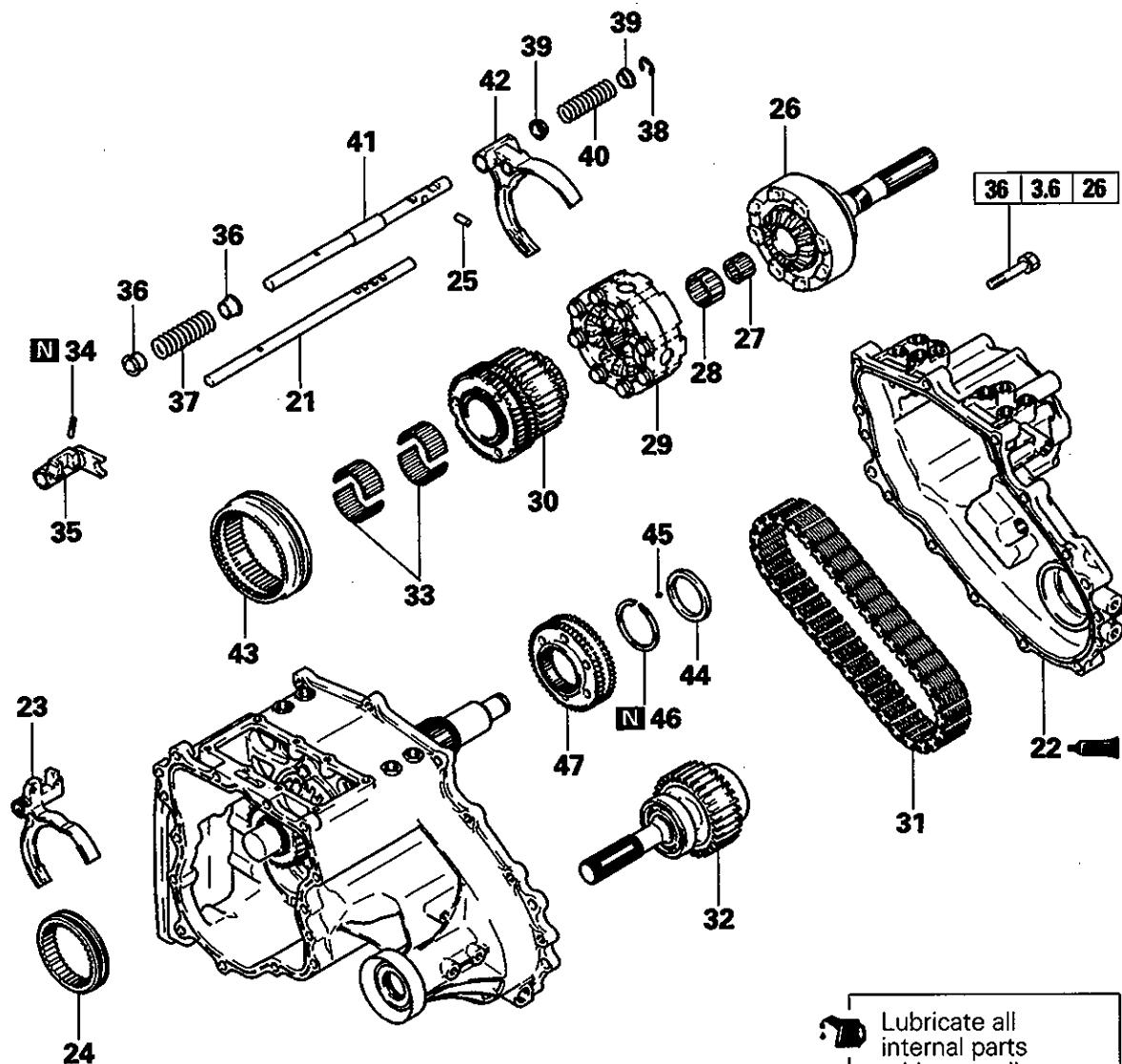

 Lubricate all internal parts with gear oil during reassembly.

Disassembly steps

- ◊A◊ ◊L◊ 21. H-L shift rail
- ◊A◊ ◊K◊ 22. Chain cover
- 23. H-L shift fork
- 24. H-L clutch sleeve
- ◊K◊ 25. Interlock plunger
- 26. Rear output shaft
- 27. Needle bearing
- 28. Needle bearing
- 29. Center differential case
- ◊B◊ ◊H◊ 30. 2-4WD synchronizer
- ◊B◊ ◊H◊ 31. Chain
- ◊B◊ ◊H◊ 32. Front output shaft
- 33. Needle bearing
- ◊C◊ ◊G◊ 34. Spring pin (2-4WD shift lug)
- ◊G◊ 35. 2-4WD shift lug
- ◊G◊ 36. Spring seat
- ◊G◊ 37. Spring
- 38. E-ring
- 39. Spring seat
- 40. Spring
- ◊G◊ 41. 2-4WD shift rail
- 42. 2-4WD shift fork
- 43. 2-4WD synchronizer sleeve
- 44. Sleeve
- 45. Steel ball
- ◊F◊ 46. Snap ring
- 47. Differential lock hub

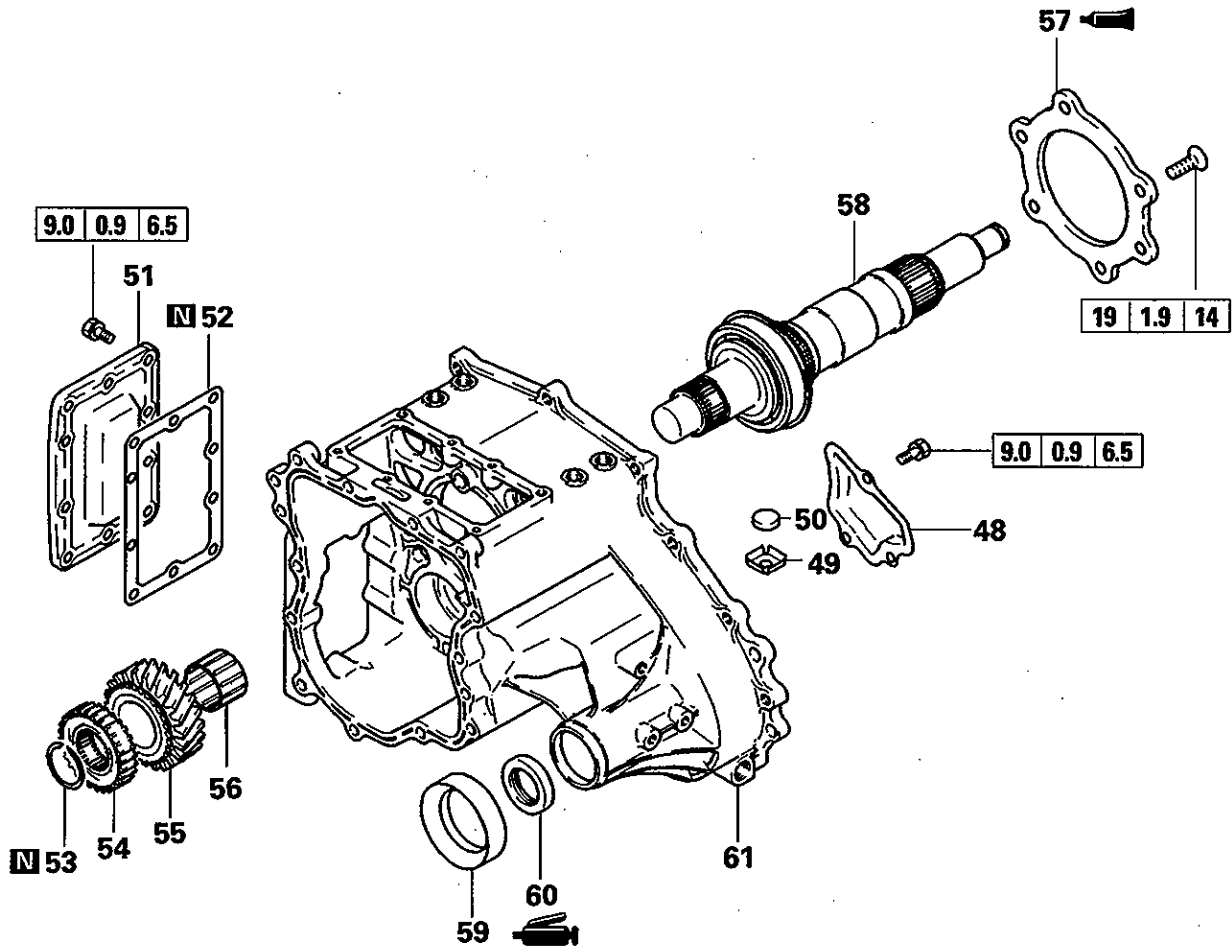

Disassembly steps

- 48. Oil pool cover
- ▶E▶ 49. Magnet holder
- ▶E▶ 50. Magnet
- 51. Side cover
- 52. Side cover gasket
- ▶D▶ 53. Snap ring
- ▶C▶ 54. H-L clutch hub
- 55. Low speed gear
- 56. Needle bearing
- ▶B▶ 57. Rear bearing retainer
- 58. Transfer drive shaft
- 59. Dust seal guard
- ▶A▶ 60. Oil seal
- 61. Transfer case

 Lubricate all internal parts with gear oil during reassembly.

DISASSEMBLY AND REASSEMBLY

<V5M31-5 PART TIME 4WD RHD>

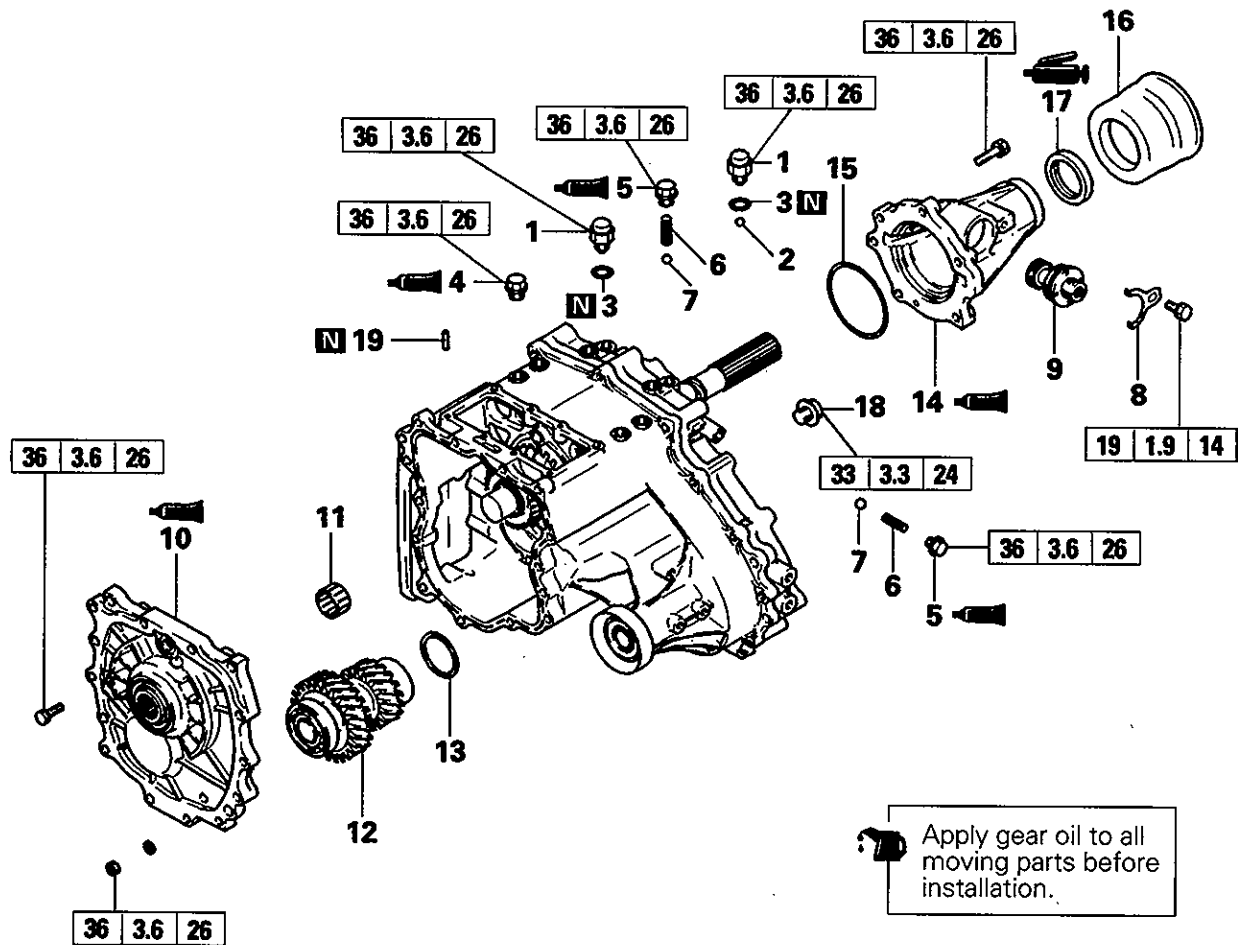

Disassembly steps

- | | | |
|-----|-------------------------|---------------------------------|
| ◆X◆ | 1. Detection switch | 11. Needle bearing |
| | 2. Steel ball | 12. Countershaft gear |
| | 3. Gasket | ◆O◆ |
| ◆V◆ | 4. Plug | ◆P◆ |
| ◆U◆ | 5. Poppet plug | ◆O◆ |
| ◆T◆ | 6. Poppet spring | 15. Spacer |
| | 7. Steel ball | 16. Dust seal guard |
| | 8. Sleeve clamp | ◆N◆ |
| ◆S◆ | 9. Speedometer gear | 17. Oil seal |
| ◆R◆ | 10. Transfer case plate | 18. H-L shift rail plug |
| | | ◆L◆ |
| | | 19. Spring pin (H-L shift fork) |

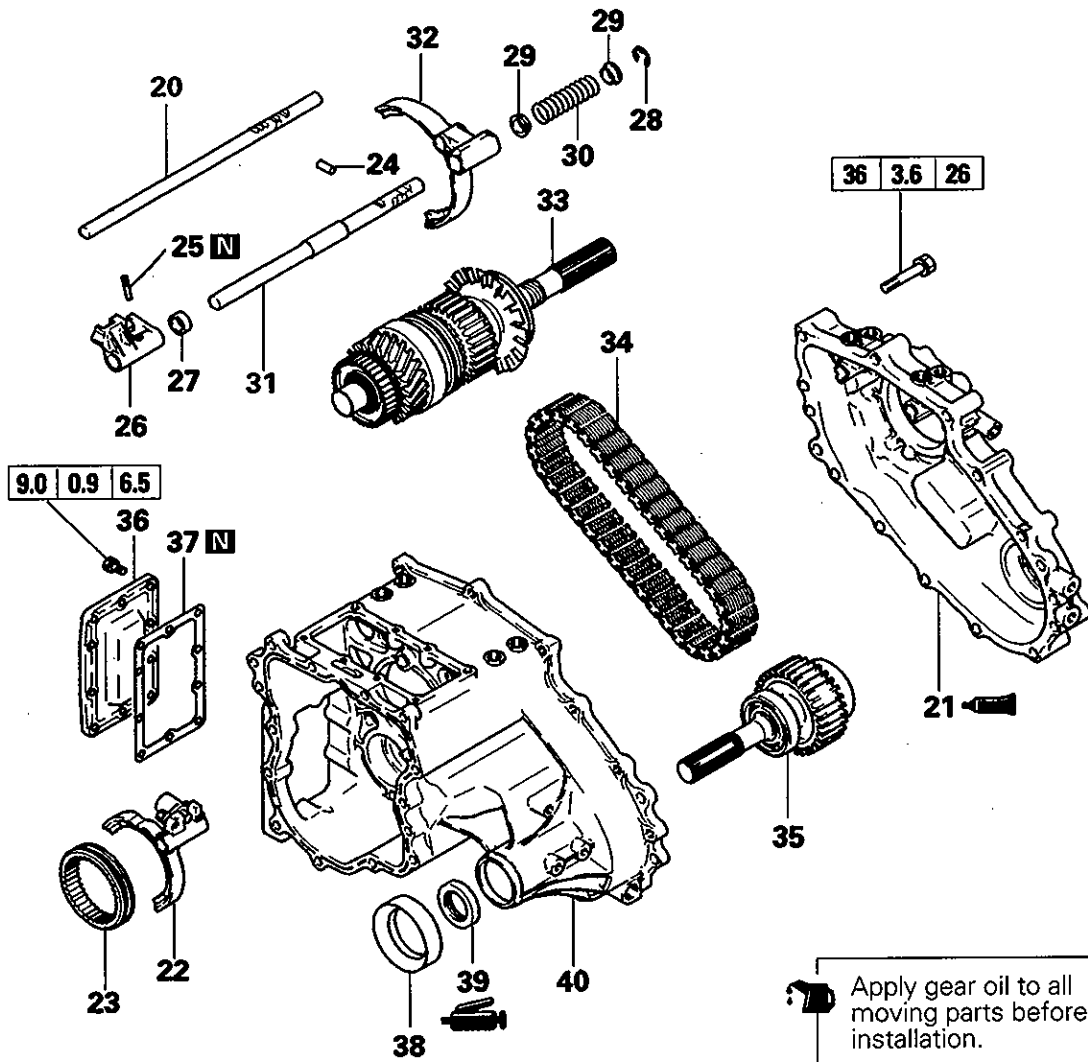

Disassembly steps

- ◊A◊ ▶L◊ 20. H-L shift rail
- ◊A◊ ▶K◊ 21. Chain cover
- 22. H-L shift fork
- 23. H-L clutch sleeve
- ▶K◊ 24. Interlock plunger
- ◊C◊ ▶J◊ 25. Spring pin (2-4WD shift lug)
- 26. 2-4WD shift lug
- 27. Distance piece
- 28. E-ring (2-4WD shift rail)
- 29. Spring seat
- 30. Spring

- 31. 2-4WD shift rail
- 32. 2-4WD shift fork
- ◊D◊ ▶I◊ 33. Rear output shaft
- ◊D◊ ▶I◊ 34. Chain
- ◊D◊ ▶I◊ 35. Front output shaft
- 36. Side cover
- 37. Side cover gasket
- 38. Dust seal guard
- ▶A◊ 39. Oil seal
- 40. Transfer case

DISASSEMBLY AND REASSEMBLY

<V5M31-5 PART TIME 4WD LHD>

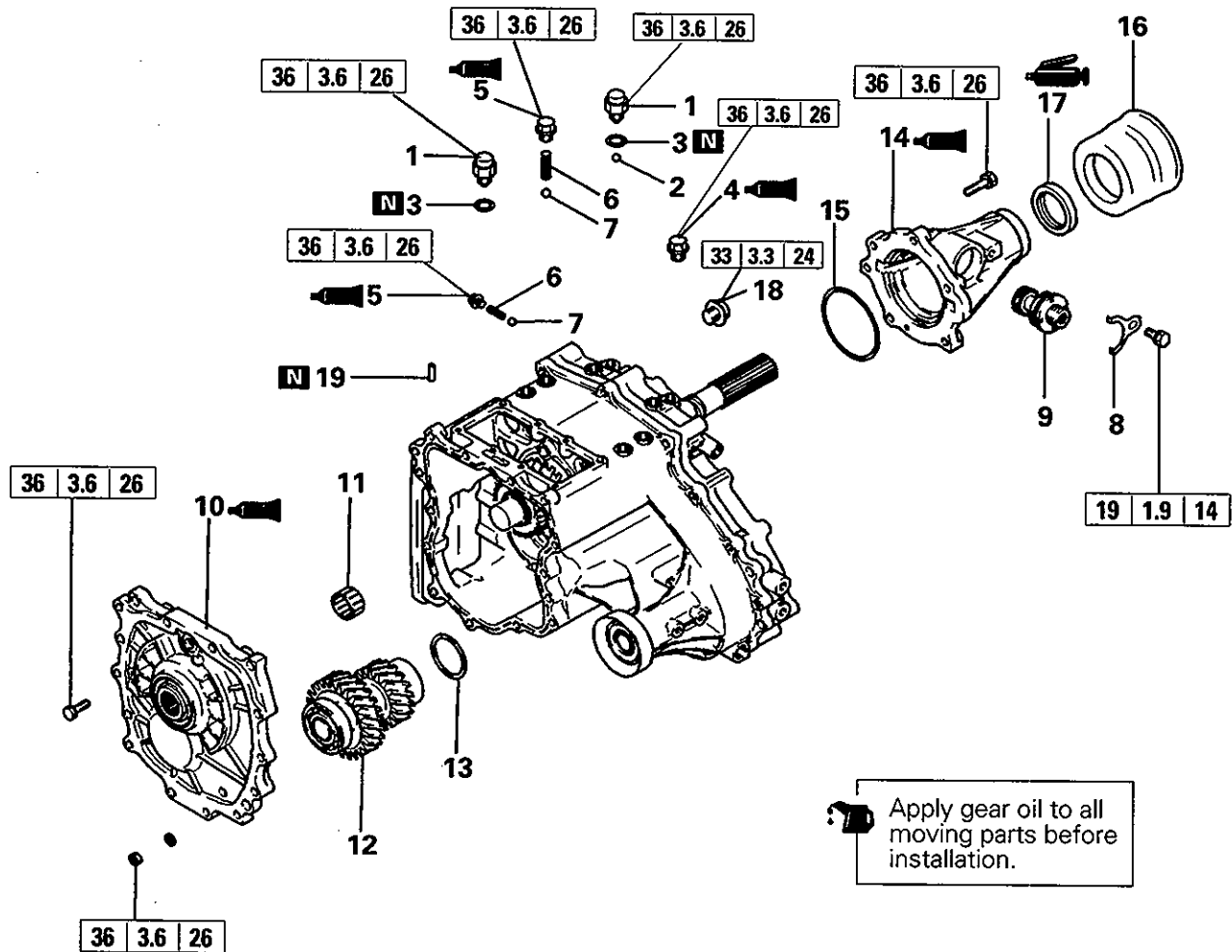

 Apply gear oil to all moving parts before installation.

Disassembly steps

- | | | |
|-----|-------------------------|---------------------------------|
| ▶X▶ | 1. Detection switch | 11. Needle bearing |
| | 2. Steel ball | 12. Countershaft gear |
| | 3. Gasket | ▶Q▶ |
| ▶V▶ | 4. Plug | ▶P▶ |
| ▶U▶ | 5. Poppet plug | ▶O▶ |
| ▶T▶ | 6. Poppet spring | 16. Dust seal guard |
| | 7. Steel ball | ▶N▶ |
| | 8. Sleeve clamp | 18. H-L shift rail plug |
| ▶S▶ | 9. Speedometer gear | ▶L▶ |
| ▶R▶ | 10. Transfer case plate | 19. Spring pin (H-L shift fork) |

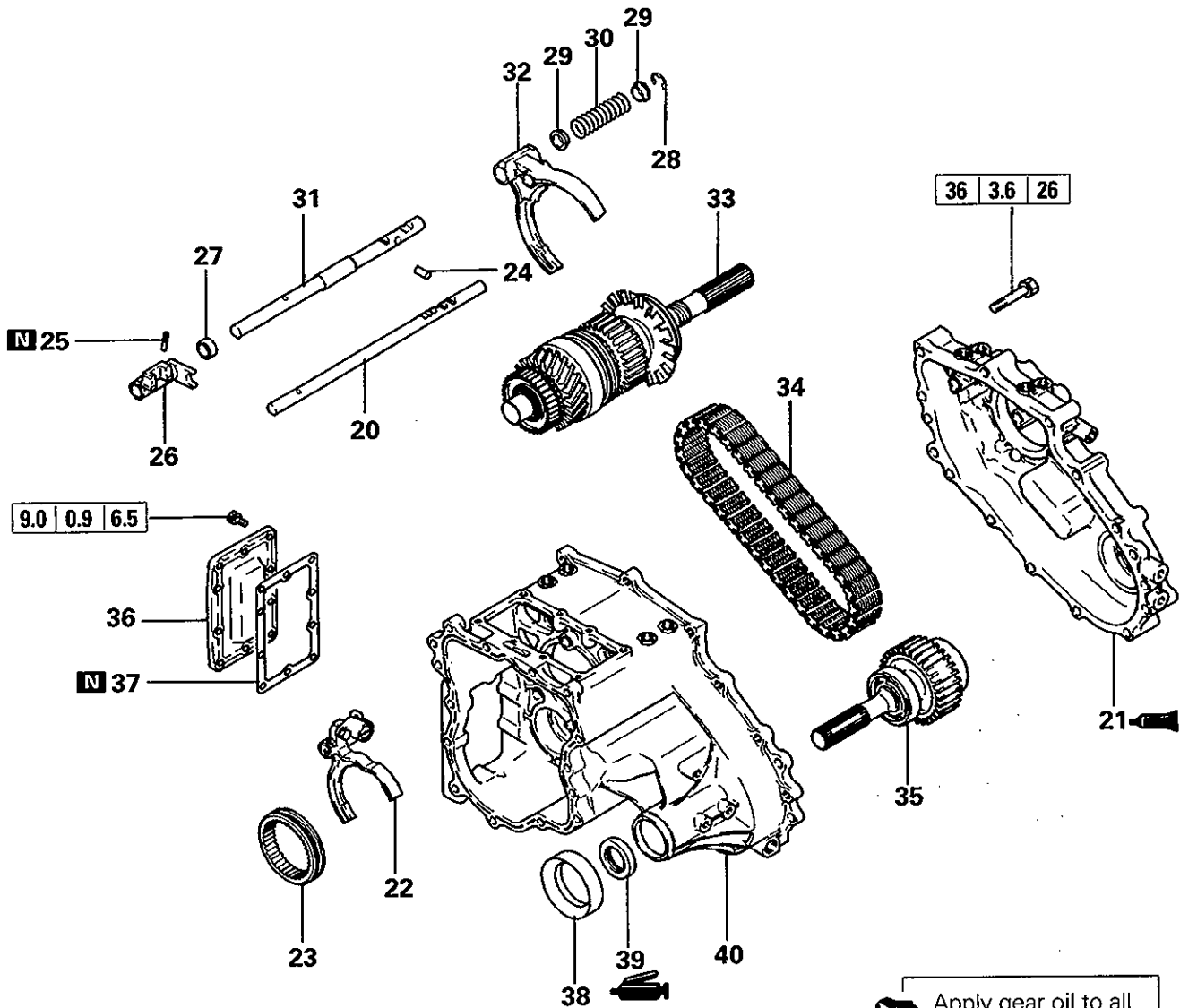

Disassembly steps

- ◇A◇ ▶L◇ 20. H-L shift rail
- ◇A◇ ▶K◇ 21. Chain cover
- 22. H-L shift fork
- 23. H-L clutch sleeve
- ▶K◇ 24. Interlock plunger
- ◇C◇ ▶J◇ 25. Spring pin (2-4WD shift lug)
- 26. 2-4WD shift lug
- 27. Distance piece
- 28. E-ring (2-4WD shift rail)
- 29. Spring seat
- 30. Spring

- 31. 2-4WD shift rail
- 32. 2-4WD shift fork
- ◇D◇ ▶I◇ 33. Rear output shaft
- ◇D◇ ▶I◇ 34. Chain
- ◇D◇ ▶I◇ 35. Front output shaft
- 36. Side cover
- 37. Side cover gasket
- 38. Dust seal guard
- ▶A◇ 39. Oil seal
- 40. Transfer case

DISASSEMBLY AND REASSEMBLY

<V5M31-6 PART TIME 4WD RHD>

Apply gear oil to all moving parts before installation.

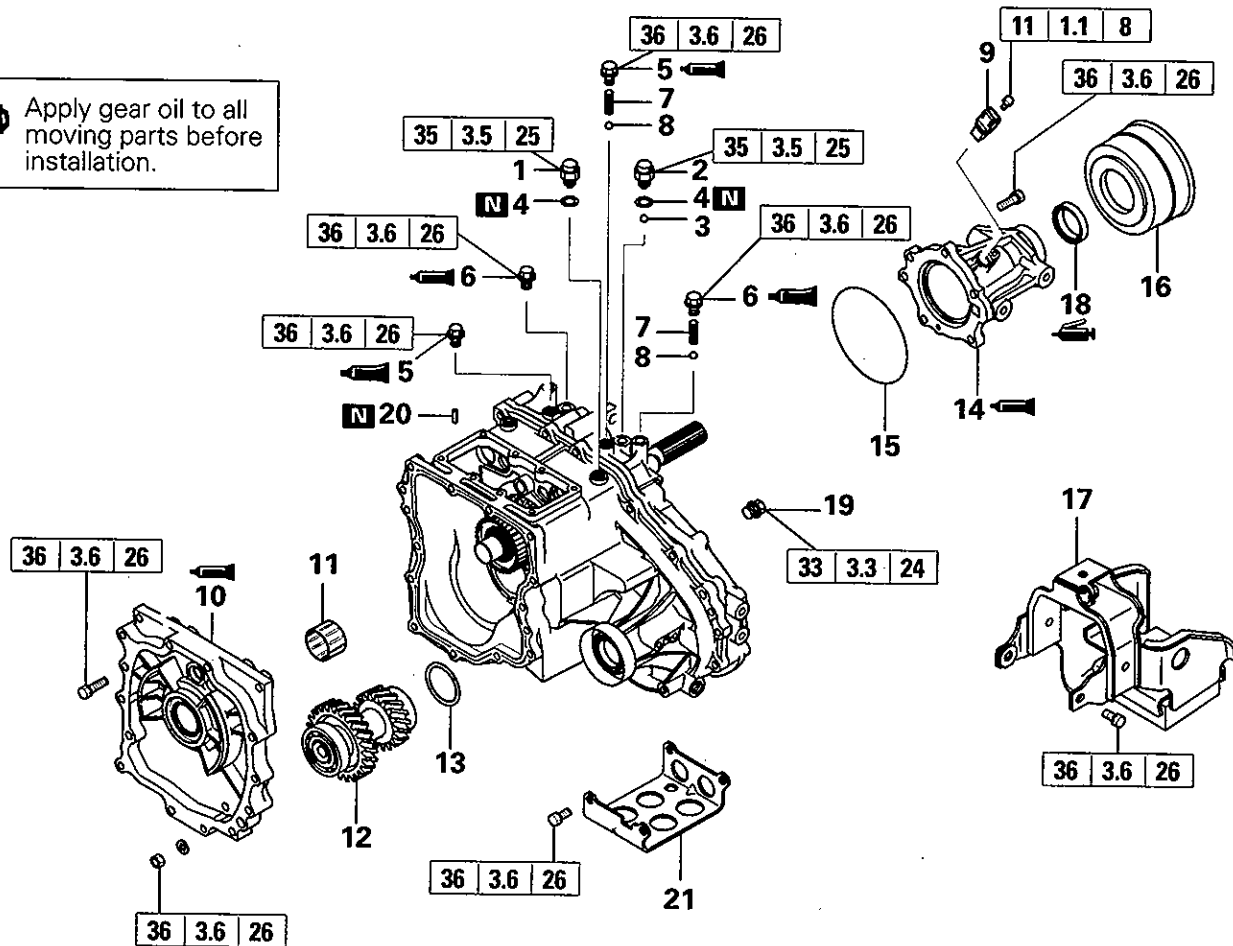

Disassembly steps

- | | |
|---------------------------|-----------------------------------|
| 1. 4WD switch | 11. Needle bearing |
| 2. Transfer switch | 12. Countershaft gear |
| 3. Steel ball | Q 13. Spacer |
| 4. Gasket | P 14. Rear cover |
| V 5. Plug | O 15. Spacer |
| U 6. Poppet plug | 16. Dust seal guard |
| T 7. Poppet spring | 17. Dynamic damper |
| 8. Steel ball | N 18. Oil seal |
| 9. Vehicle speed sensor | 19. H-L shift rail plug |
| R 10. Transfer case plate | L 20. Spring pin (H-L shift fork) |
| | 21. Under guard <EXP> |

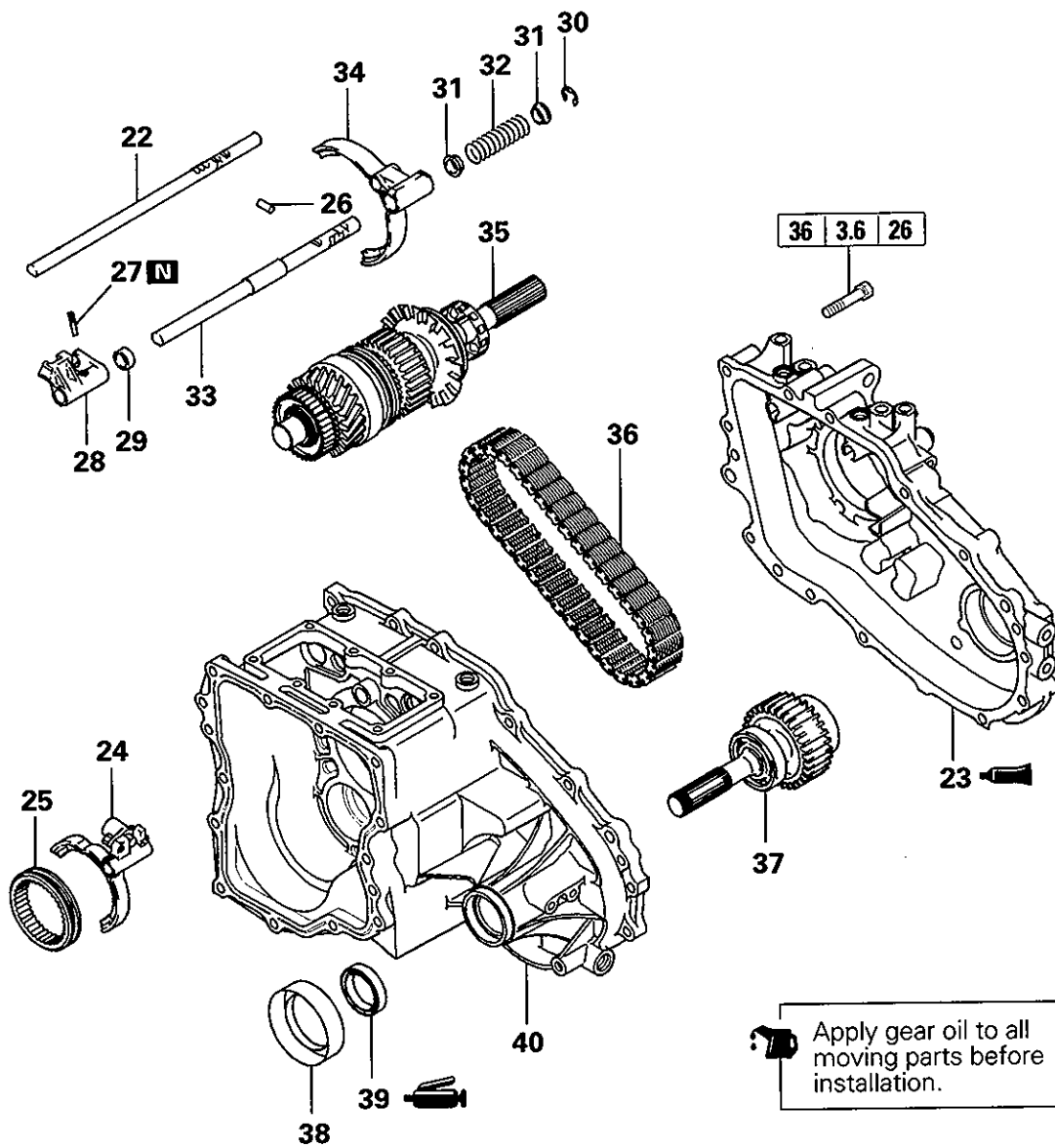

 Apply gear oil to all moving parts before installation.

Disassembly steps

- ◊A◊ ▶L◊ 22. H-L shift rail
- ◊A◊ ▶K◊ 23. Chain cover
- 24. H-L shift fork
- 25. H-L clutch sleeve
- ▶K◊ 26. Interlock plunger
- ◊C◊ ▶J◊ 27. Spring pin (2-4WD shift lug)
- 28. 2-4WD shift lug
- 29. Distance piece
- 30. E-ring (2-4WD shift rail)
- 31. Spring seat
- 32. Spring

- 33. 2-4WD shift rail
- 34. 2-4WD shift fork
- ◊D◊ ▶I◊ 35. Rear output shaft
- ◊D◊ ▶I◊ 36. Chain
- ◊D◊ ▶I◊ 37. Front output shaft
- 38. Dust seal guard
- ▶A◊ 39. Oil seal
- 40. Transfer case

DISASSEMBLY AND REASSEMBLY

<V5M31-6 PART TIME 4WD LHD>

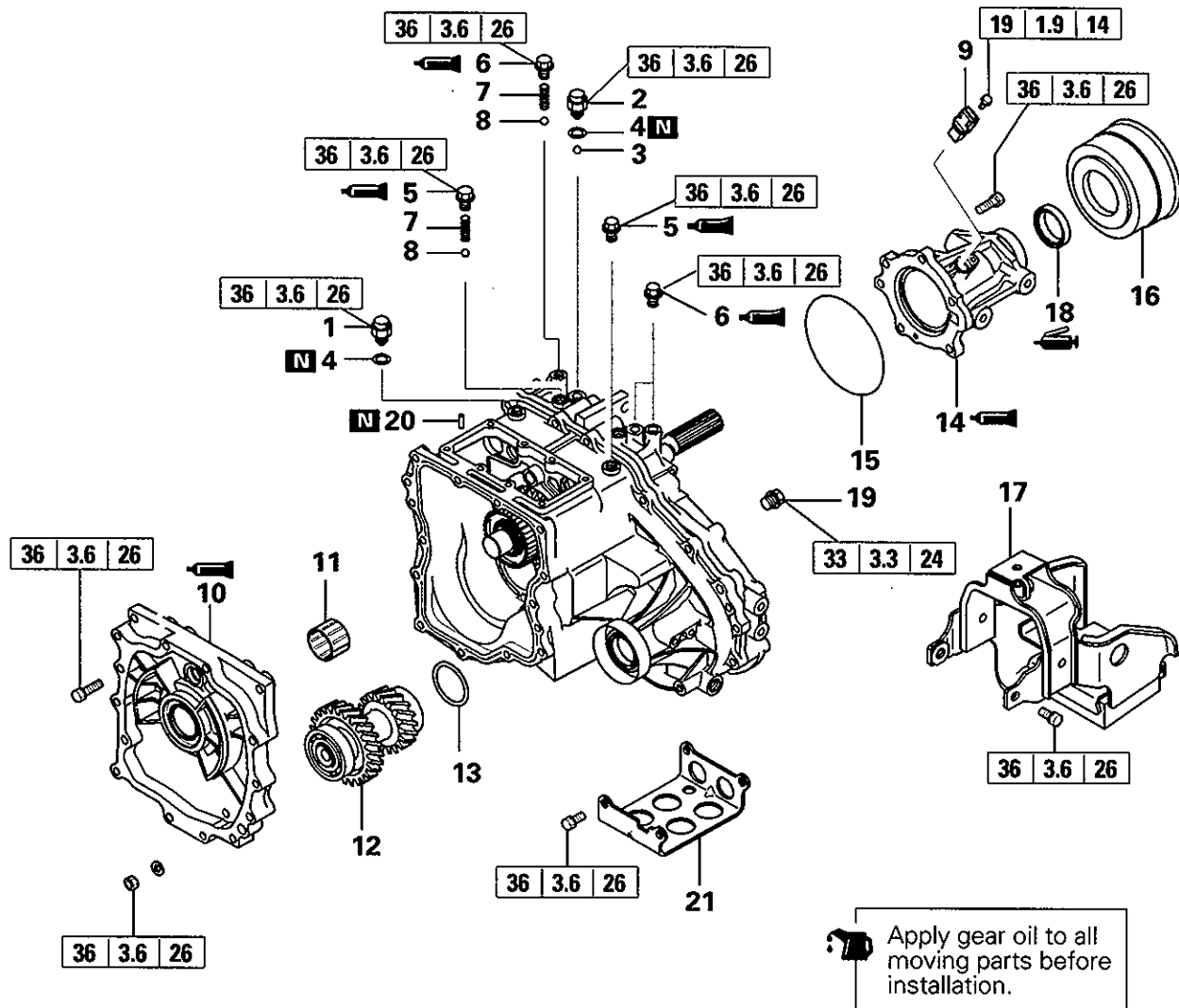

Disassembly steps

- | | |
|-----------------------------|-------------------------------------|
| 1. 4WD switch | 11. Needle bearing |
| 2. Transfer switch | 12. Countershaft gear |
| 3. Steel ball | ▶Q▶ 13. Spacer |
| 4. Gasket | ▶P▶ 14. Rear cover |
| ▶V▶ 5. Plug | ▶O▶ 15. Spacer |
| ▶U▶ 6. Poppet plug | 16. Dust seal guard |
| ▶T▶ 7. Poppet spring | 17. Dynamic damper |
| 8. Steel ball | ▶N▶ 18. Oil seal |
| 9. Vehicle speed sensor | 19. H-L shift rail plug |
| ▶R▶ 10. Transfer case plate | ▶L▶ 20. Spring pin (H-L shift fork) |
| | 21. Under guard <EXP> |

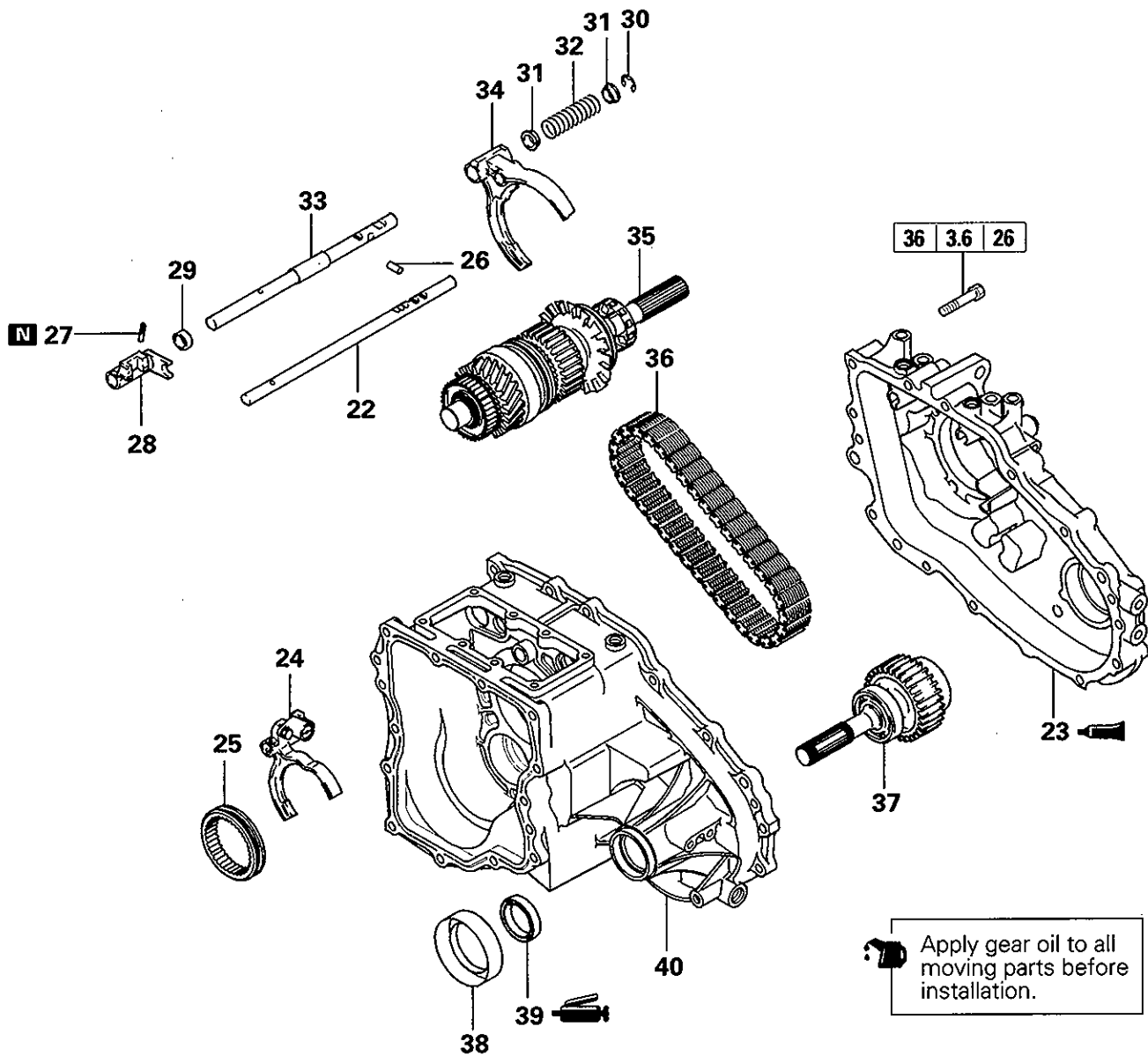

Disassembly steps

- ◊A◊ ▶L◊ 22. H-L shift rail
- ◊A◊ ▶K◊ 23. Chain cover
- 24. H-L shift fork
- 25. H-L clutch sleeve
- ▶K◊ 26. Interlock plunger
- ◊C◊ ▶J◊ 27. Spring pin (2-4WD shift lug)
- 28. 2-4WD shift lug
- 29. Distance piece
- 30. E-ring (2-4WD shift rail)
- 31. Spring seat
- 32. Spring

- 33. 2-4WD shift rail
- 34. 2-4WD shift fork
- ◊D◊ ▶I◊ 35. Rear output shaft
- ◊D◊ ▶I◊ 36. Chain
- ◊D◊ ▶I◊ 37. Front output shaft
- 38. Dust seal guard
- ▶A◊ 39. Oil seal
- 40. Transfer case

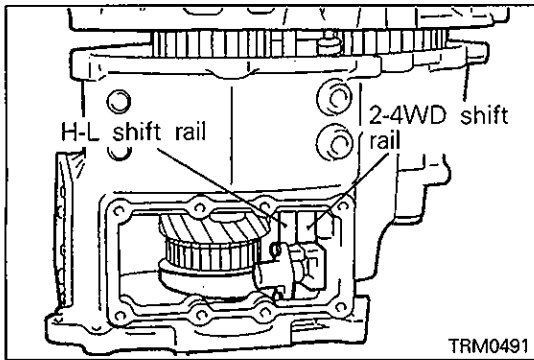
**DISASSEMBLY SERVICE POINTS****◁A▷ H-L SHIFT RAIL / CHAIN COVER REMOVAL**

- (1) Fix the H-L shift rail at the High side.
- (2) Place the 2-4WD shift rail at the 4WD position.

NOTE

If the 2-4WD shift rail is placed at the 2WD position, the chain cover cannot be removed because of interlocking.

- (3) Remove the chain cover and remove H-L shift rail.

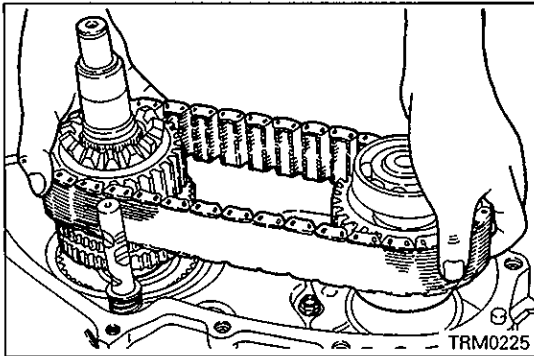
**◁B▷ 2-4WD SYNCHRONIZER / CHAIN / FRONT OUTPUT SHAFT REMOVAL**

- (1) Remove the 2-4WD synchronizer, chain and front output shaft as a set.

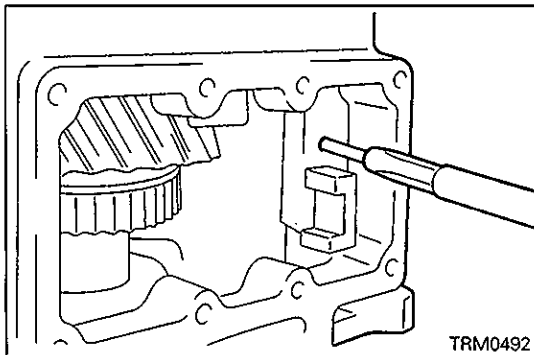
**◁C▷ SPRING PIN REMOVAL****Caution**

- The spring pin may fly out.

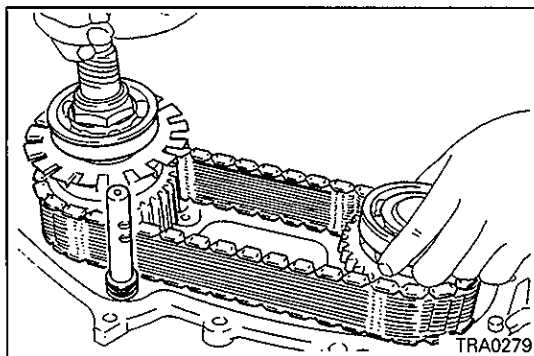
**◁D▷ REAR OUTPUT SHAFT / CHAIN / FRONT OUTPUT SHAFT REMOVAL**

- (1) Remove the rear output shaft, chain and front output shaft in a set.

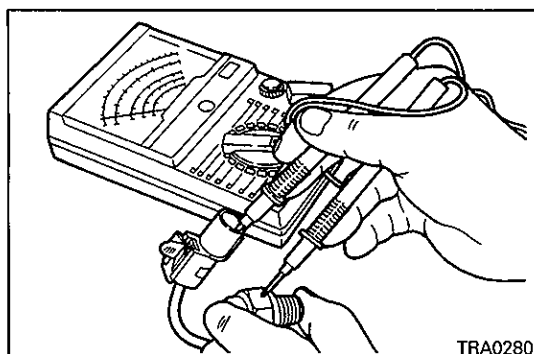
**INSPECTION****DETECTION SWITCH**

- (1) Check for continuity between the connector terminal and switch body.

Switch state	Continuity
Switch end pressed	No
Switch end released	Yes

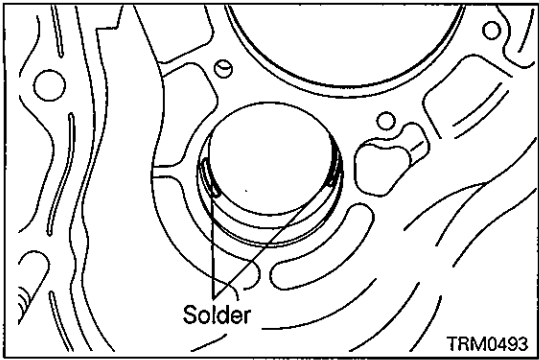

ADJUSTMENT BEFORE REASSEMBLY

SPACER SELECTION FOR ADJUSTMENT OF COUNTER-SHAFT GEAR END PLAY

- (1) Place pieces of solder [about 10 mm (0.39 in.) in length and 1.6 mm (0.063 in.) in diameter] on the transfer case as illustrated.
- (2) Put the countershaft gear and the transfer case plate and tighten the bolts to the specified torque.
- (3) If the solder is not crushed, repeat the steps (1) and (2) using a thicker solder.

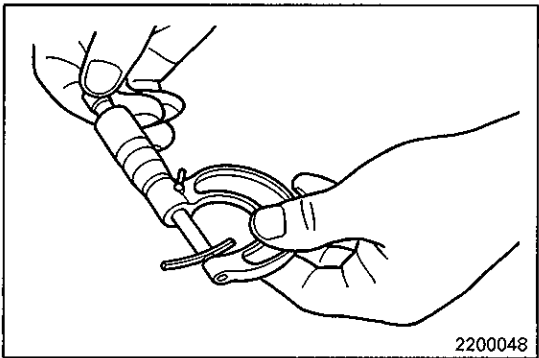

- (4) Using a micrometer, measure the thickness of the crushed solder. Based on the result, select a spacer which adjusts the end play to the standard value shown below:

Standard value: 0 – 0.15 mm (0 – 0.0059 in.)

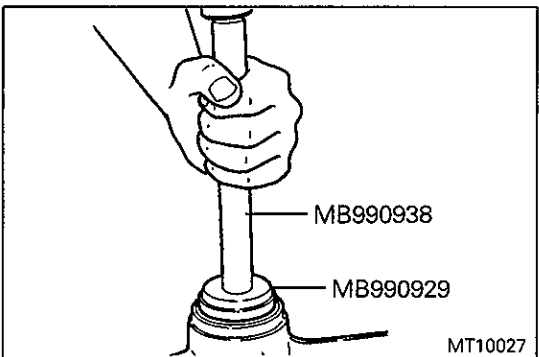

REASSEMBLY SERVICE POINTS

▶◀ OIL SEAL INSTALLATION

- (1) Apply grease to the lip of the oil seal after press-fitting.

Specified grease:

Mitsubishi genuine grease Part No. 0101011 or equivalent

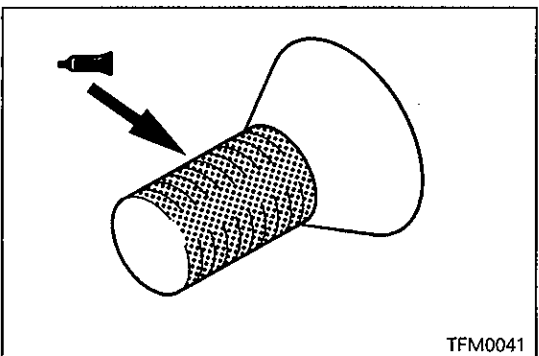

▶◀ REAR BEARING RETAINER INSTALLATION

- (1) The rear bearing retainer mounting bolt is a precoated one. When it is to be reused, apply sealant beforehand.

Specified sealant:

3M STUD Locking No. 4170 or equivalent

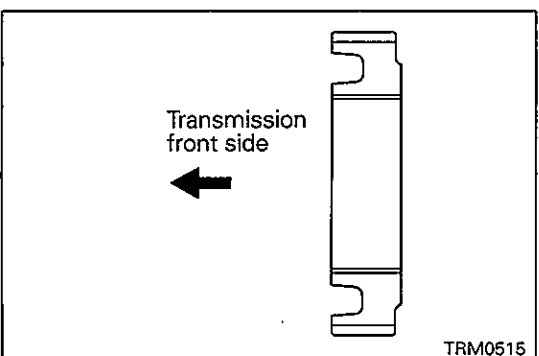

▶◀ H-L CLUTCH HUB INSTALLATION

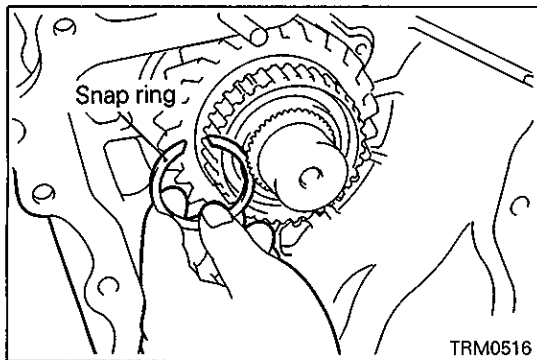

◆D◆ SNAP RING INSTALLATION

- (1) Select a snap ring which adjusts the end play of the clutch hub to the standard value shown below:

Standard value: 0 – 0.08 mm (0 – 0.0031 in.)

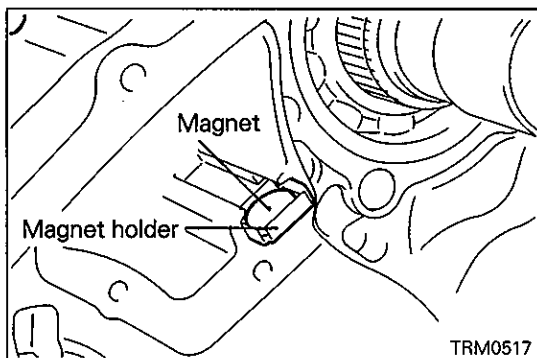

◆E◆ MAGNET / MAGNET HOLDER INSTALLATION

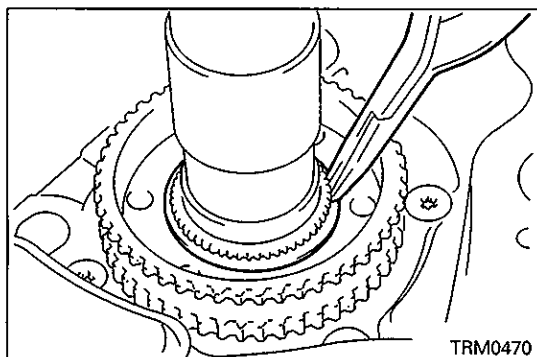

◆F◆ SNAP RING INSTALLATION

- (1) Select a snap ring which adjusts the end play of the differential lock hub to the standard value shown below:

Standard value: 0 – 0.08 mm (0 – 0.0031 in.)

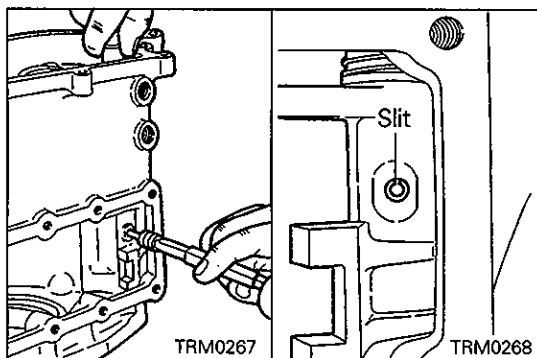

◆G◆ 2-4WD SHIFT RAIL / SPRING / SPRING SEAT / 2-4WD SHIFT LUG / SPRING PIN INSTALLATION

- (1) Attach the spring seat and the spring to the shift rail and set the shift lug onto the shift rail from inside the transfer case.
- (2) Push in the shift rail while paying attention to the direction of the hole in the shift rail, then line up the spring pin holes in the shift lug and the shift rail.
- (3) While pressing the shift rail, install the spring pin in such a way that the slit of the spring pin will face the axial center of the shift rail.

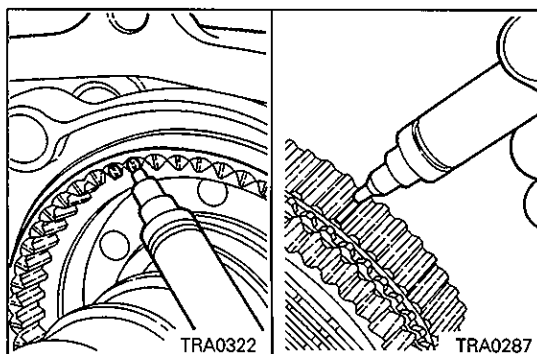

◆H◆ FRONT OUTPUT SHAFT / CHAIN / 2-4WD SYNCHRONIZER INSTALLATION

- (1) Make a white paint mark on the deep grooves (three places) in the 2-4WD synchronizer.
- (2) Make a white paint mark on the projections (three places) of the 2-4WD synchronizer sleeve splines.

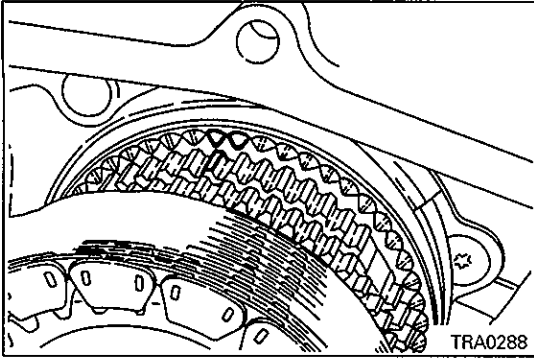

- (3) Place the chain in tight mesh with the 2-4WD synchronizer and front output shaft sprockets.
- (4) With both sprockets spaced the farthest apart, install them in the transfer case.

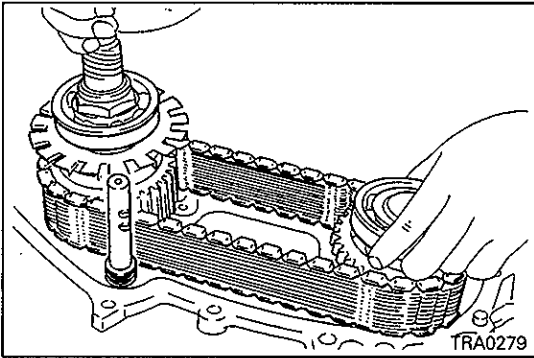

▶◀ FRONT OUTPUT SHAFT / CHAIN / REAR OUTPUT SHAFT INSTALLATION

- (1) Place the chain in tight mesh with the sprockets of the rear output shaft and the front output shaft.
- (2) Install the 2-4WD shift fork to the 2-4WD clutch sleeve. While inserting the 2-4WD shift rail in the fork hole, install the front and rear output shafts.

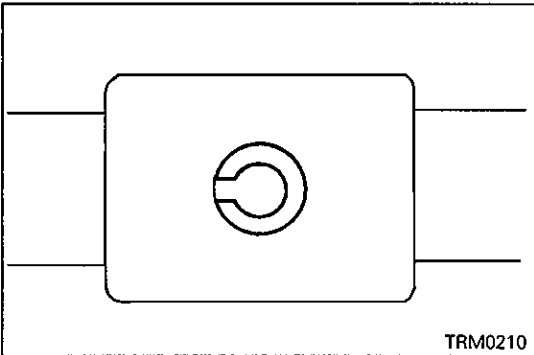

▶◀ SPRING PIN INSTALLATION

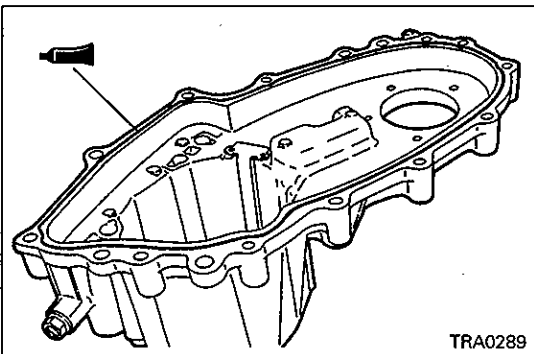

▶◀ INTERLOCK PLUNGER / CHAIN COVER INSTALLATION

- (1) Insert the interlock plunger into a position where it does not interfere with the 2-4WD shift rail.
- (2) Apply a bead of sealant to the chain cover as illustrated beforehand.

Specified sealant:

Mitsubishi genuine sealant Part No. MD997740 or equivalent

Caution

- Squeeze sealant out evenly to make sure that it is not broken or excessively supplied.

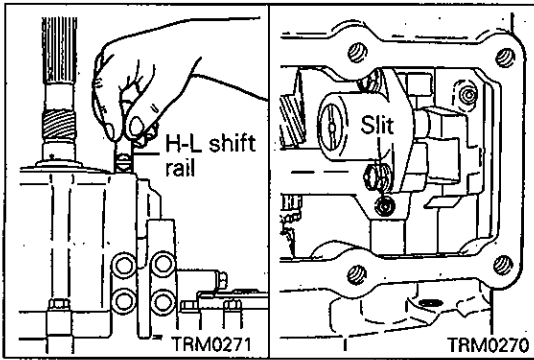

▶L◀ H-L SHIFT RAIL / SPRING PIN INSTALLATION

- (1) Insert the H-L shift rail in the H-L shift rail mounting hole in the transfer case, while paying attention to the hole direction.
- (2) Line up the spring pin holes in the shift rail and the shift fork and install the spring pin so that the slit of the spring pin will face the axial center of the shift rail.

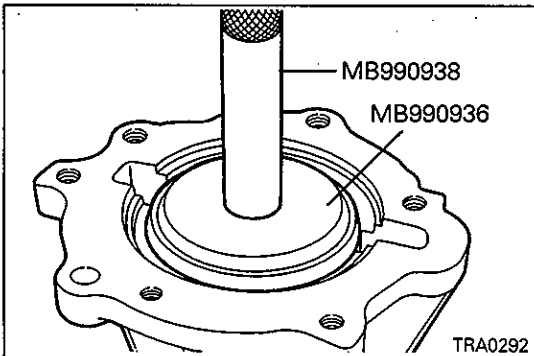

▶M◀ OIL SEAL INSTALLATION

- (1) Apply grease to the lip of the oil seal after press-fitting.

Specified grease:

Mitsubishi genuine grease Part No. 0101011 or equivalent

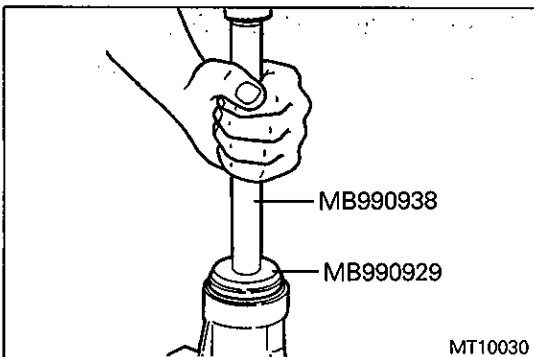

▶N◀ OIL SEAL INSTALLATION

- (1) Apply grease to the lip of the oil seal after press-fitting.

Specified grease:

Mitsubishi genuine grease Part No. 0101011 or equivalent

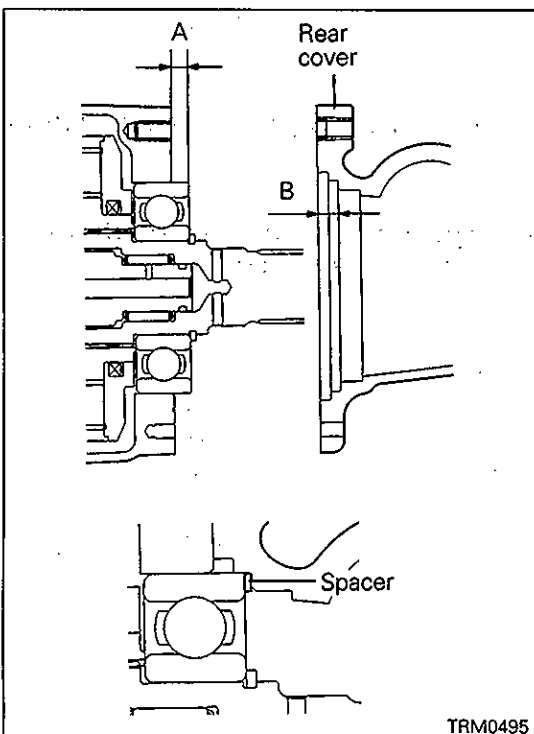

▶O◀ SPACER INSTALLATION

- (1) Measure projection "A" of the rear output shaft bearing and depth "B" of the second stage of the rear cover.
- (2) Subtract "A" from "B" and let the answer be "C". Subtract the thickness of the spacer from "C", and select a spacer so that the subtracted value will be the standard value shown below.

Standard value: 0 – 0.1 mm (0 – 0.004 in.)

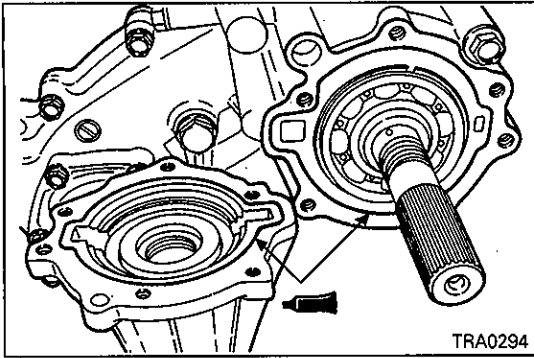

▶P◀ REAR COVER INSTALLATION

- (1) Apply a bead of sealant to the rear cover as illustrated.

Specified sealant:

Mitsubishi genuine sealant Part No. MD997740 or equivalent

Caution

- Squeeze sealant out evenly to make sure that it is not broken or excessively supplied.

▶Q◀ SPACER INSTALLATION

- (1) Install the previously selected spacer (see "ADJUSTMENT BEFORE REASSEMBLY").

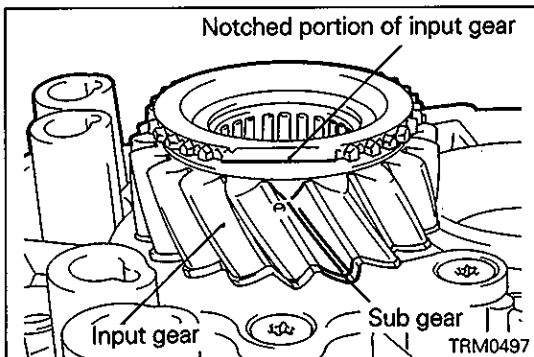

▶R◀ TRANSFER CASE PLATE INSTALLATION

- (1) Align one of the sub gear teeth with the notched tooth of the input gear.

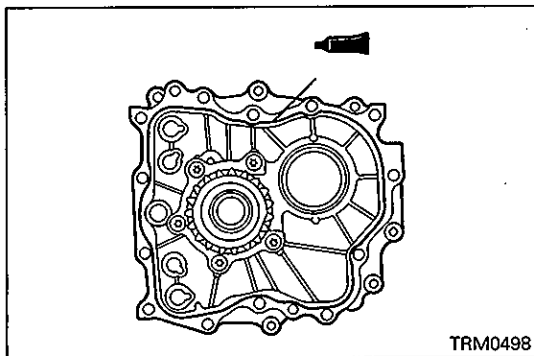

- (2) Apply a bead of sealant to the transfer case plate as illustrated.

Specified sealant:

Mitsubishi genuine sealant Part No. MD997740 or equivalent

Caution

- Squeeze sealant out evenly to make sure that it is not broken or excessively supplied.

- (3) Install the transfer case plate together with the input gear, while sliding the input gear tooth aligned in Step (1) along the tooth space of the countershaft cluster gear.

NOTE

The transfer case plate must be installed smoothly without hitch.

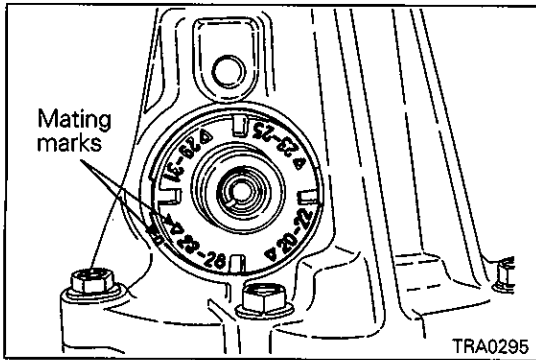

▶S◀ SPEEDOMETER GEAR INSTALLATION

- (1) Match the mating marks to the number of teeth.

Caution

- The number marked on the sleeve is the number of teeth of the driven gear.

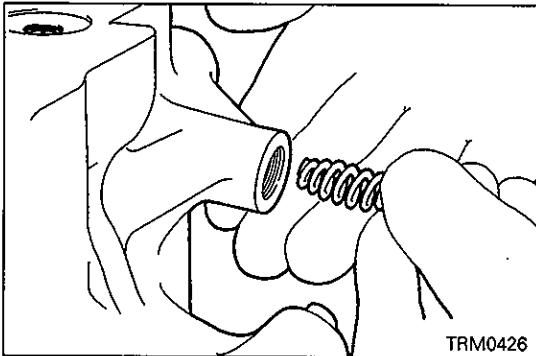

▶T◀ POPPET SPRING INSTALLATION

- (1) Install the spring with its tapered end toward the ball.

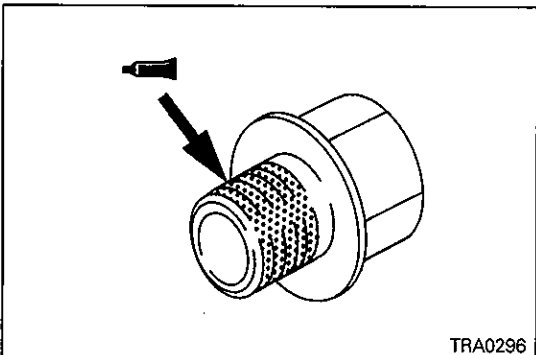

▶U◀ POPPET PLUG INSTALLATION

- (1) The poppet plug is a precoated plug. When it is to be reused, apply sealant beforehand.

Specified sealant: 3M ATD Part No. 8660 or equivalent

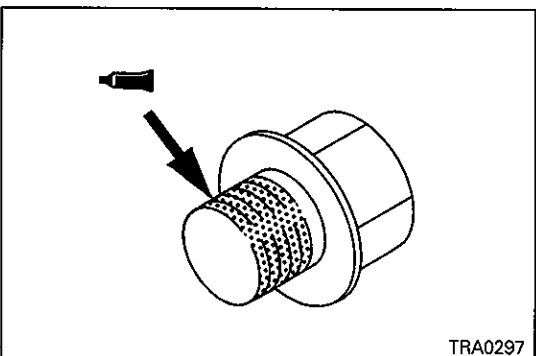

▶V◀ PLUG INSTALLATION

- (1) The plug is a precoated plug. When it is to be reused, apply sealant beforehand.

Specified sealant: 3M ATD Part No. 8660 or equivalent

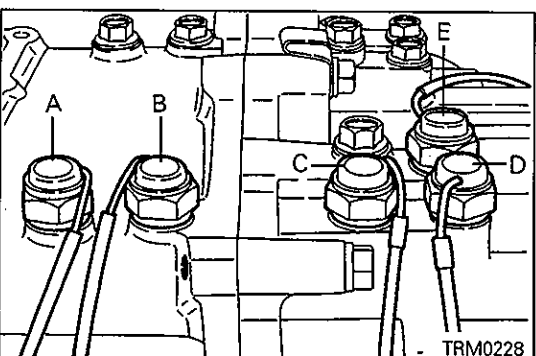

▶W◀ DETECTION SWITCH INSTALLATION

- (1) Mount the detection switches in the right positions, while using care to prevent confusion.

- A: Ball built in, connector brown
- B: Ball built in, connector black
- C: Ball separate, connector brown
- D: Ball separate, connector black
- E: Ball separate, connector white

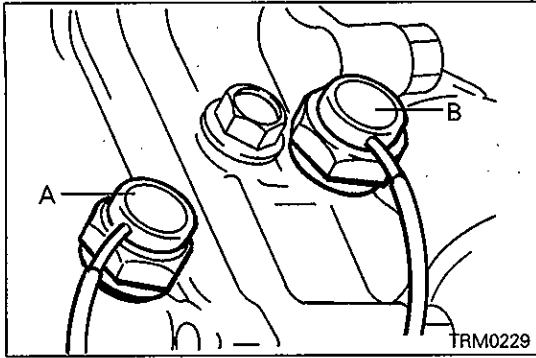
**◆X◆ DETECTION SWITCH INSTALLATION**

(1) Mount the detection switches in the right positions, while being careful not to confuse anything.

- A: Ball built in
- B: Ball separate

7a. TRANSFER <V5M31 – SUPER SELECT 4WD II> DISASSEMBLY AND REASSEMBLY

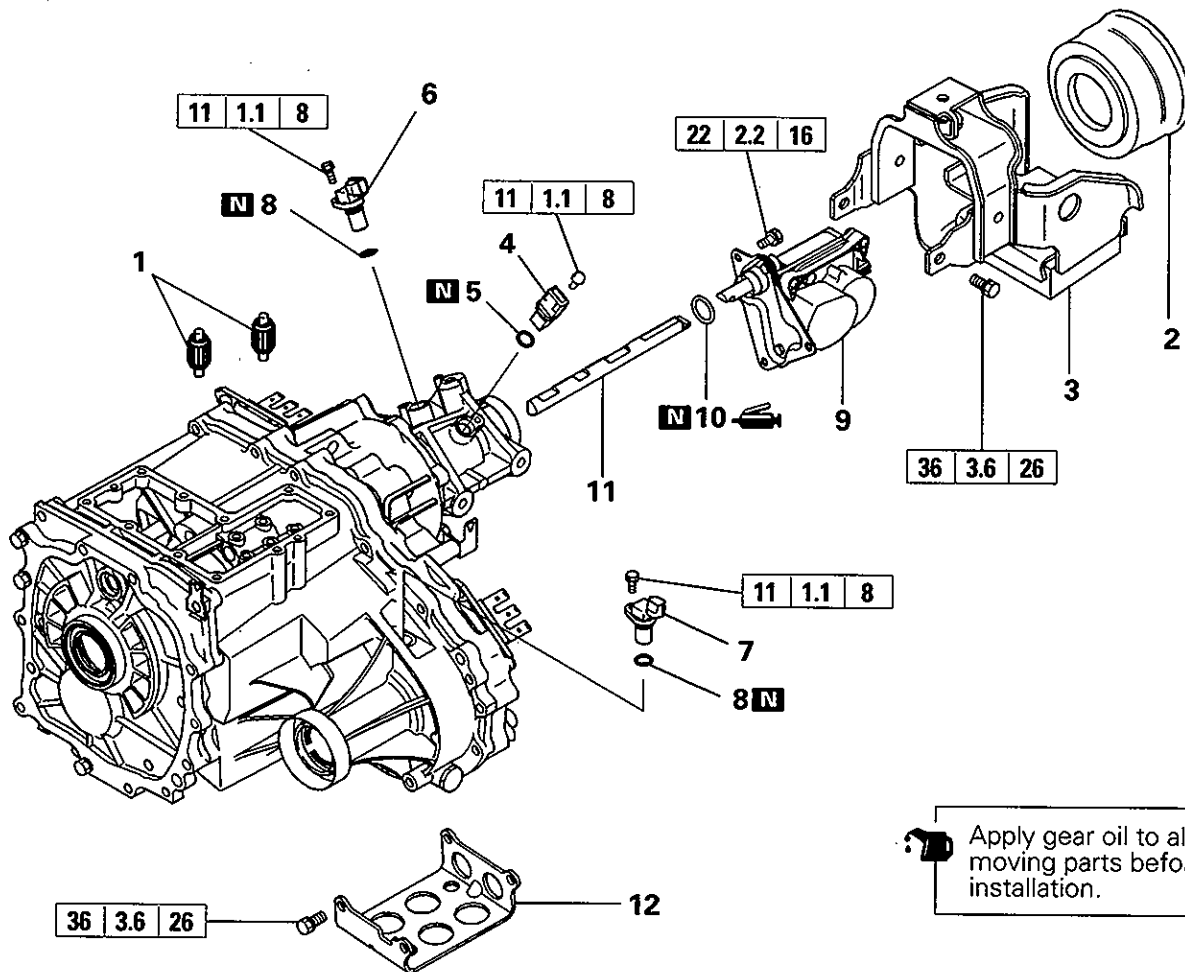

Disassembly steps

- ▶V▶ 1. Shift rail drive gear
- 2. Dust seal guard
- 3. Dynamic damper
- 4. Vehicle speed sensor
- 5. O-ring
- 6. Rear output sensor
- 7. Front output sensor
- 8. O-ring
- ▶U▶ 9. Shift actuator
- 10. O-ring
- ▶U▶ 11. Main shift rail
- 12. Under guard <EXP>

Apply gear oil to all moving parts before installation.

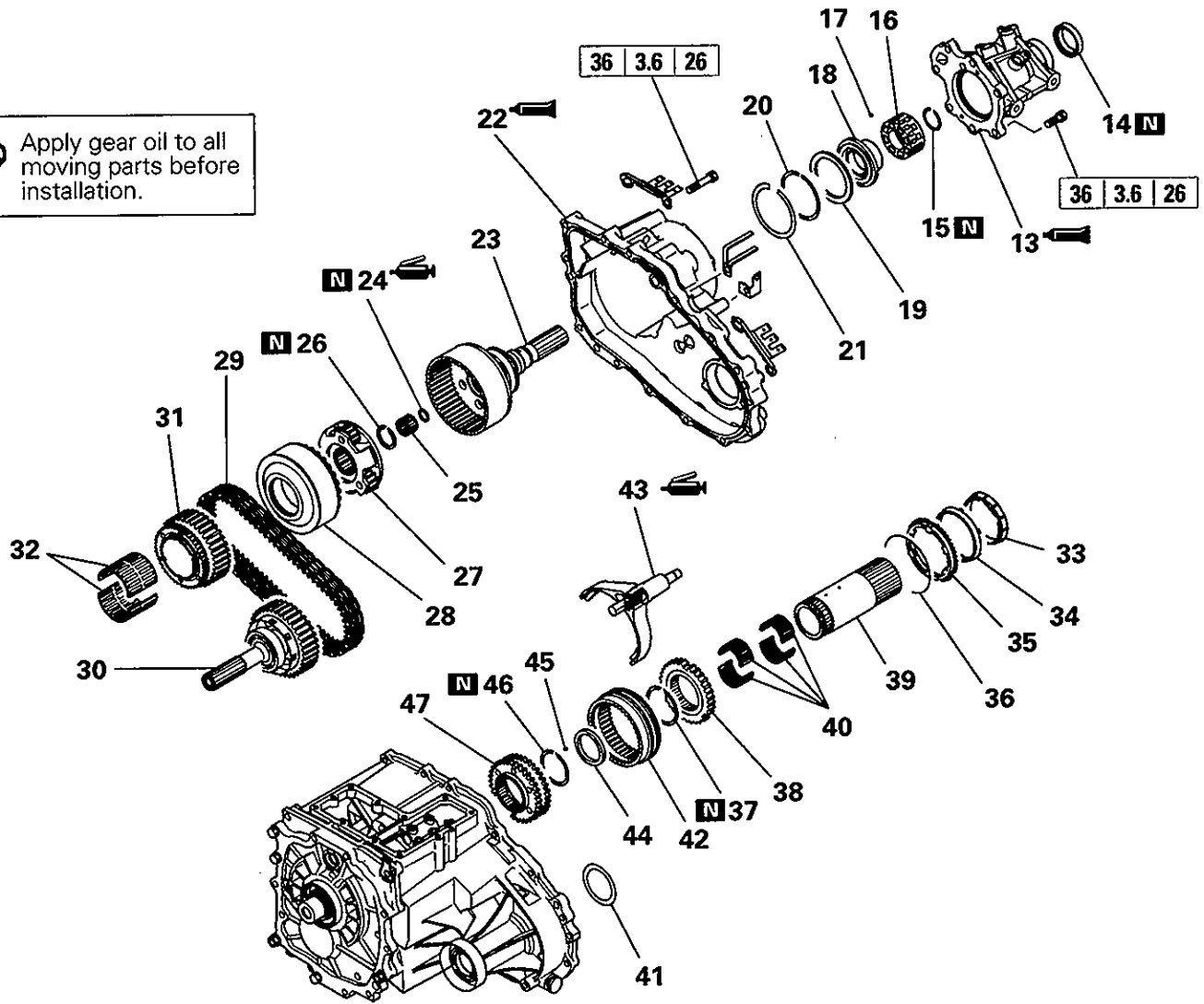

Disassembly steps

- | | | | |
|--------|---|--------|-----------------------------|
| ▶T▶ | 13. Rear cover | ▶N▶ | 31. Drive sprocket |
| ▶S▶ | 14. Oil seal | ▶M▶ | 32. Needle bearing |
| | 15. Snap ring | ▶M▶ | 33. Synchronizer inner ring |
| | 16. Sensor rotor | ▶M▶ | 34. Synchronizer cone |
| | 17. Steel ball | ▶M▶ | 35. Synchronizer outer ring |
| | 18. Oil guide | | 36. Synchronizer spring |
| ▶R▶ | 19. Spacer | ▶L▶ | 37. Snap ring |
| | 20. Snap ring | ▶L▶ | 38. 2-4WD clutch hub |
| ▶Q▶ | 21. Snap ring | ◀A▶▶L▶ | 39. Sun gear |
| ▶P▶ | 22. Chain cover | | 40. Needle bearing |
| ▶O▶ | 23. Rear output shaft | | 41. Wave spring |
| | 24. O-ring | ▶K▶ | 42. 2-4WD clutch sleeve |
| | 25. Needle bearing | ▶K▶ | 43. 2-4WD shift fork |
| | 26. Snap ring | ▶J▶ | 44. Spacer |
| | 27. Center differential planetary carrier | ▶J▶ | 45. Steel ball |
| | 28. Viscous coupling | ▶I▶ | 46. Snap ring |
| ◀A▶▶N▶ | 29. Chain | | 47. Differential lock hub |
| ◀A▶▶N▶ | 30. Front output shaft | | |

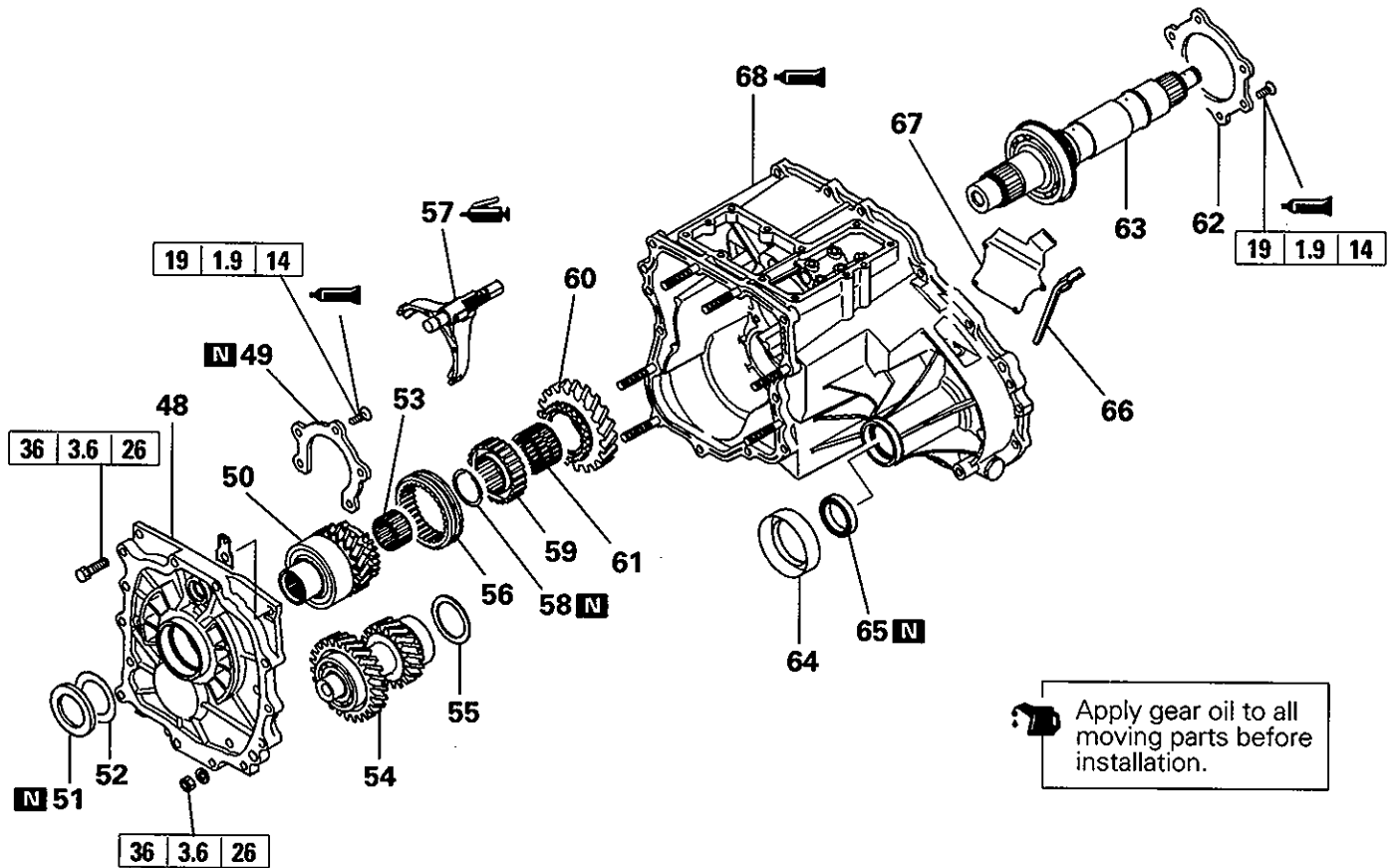

Disassembly steps

- | | | | |
|-----|----------------------------|-------------------------|---------------------------|
| ◆H◆ | 48. Transfer case plate | 59. High/low clutch hub | |
| ◆C◆ | 49. Front bearing retainer | 60. Low speed gear | |
| | 50. Input gear | 61. Needle bearing | |
| ◆G◆ | 51. Oil seal | ◆C◆ | 62. Rear bearing retainer |
| | 52. Baffel plate | | 63. Transfer drive shaft |
| | 53. Needle bearing | | 64. Dust seal guard |
| | 54. Countershaft gear | ◆B◆ | 65. Oil seal |
| ◆F◆ | 55. Spacer | | 66. Oil guide |
| ◆E◆ | 56. High/low clutch sleeve | ◆B◆◆A◆ | 67. Oil pool cover |
| ◆E◆ | 57. High/low shift fork | | 68. Transfer case |
| ◆D◆ | 58. Snap ring | | |

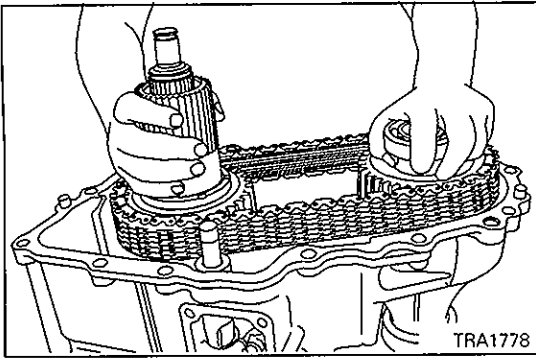

DISASSEMBLY SERVICE POINTS

◊A◊ CHAIN / FRONT OUTPUT SHAFT / SUN GEAR REMOVAL

- (1) Remove the chain, front output shaft and sun gear as a set from the transfer case.

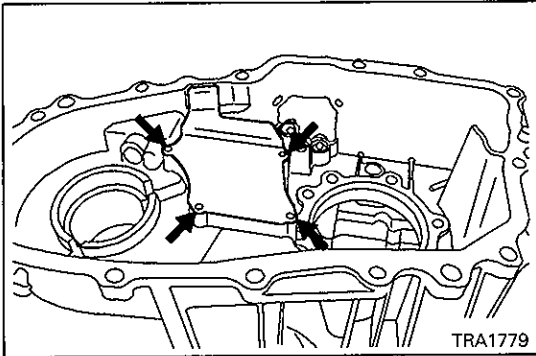

◊B◊ OIL POOL COVER REMOVAL

- (1) Unstake the positions shown in the illustration to remove the oil pool cover.

Caution

- The oil pool cover normally does not require disassembly. Once it is removed, the transfer case cannot be reused.

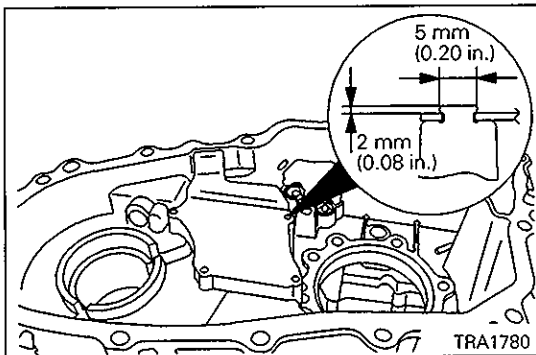

REASSEMBLY SERVICE POINTS

▶A◄ OIL POOL COVER INSTALLATION

- (1) Install the oil pool cover on a new transfer case. Stake the projecting portions of the transfer so that the dimensions will be as illustrated.

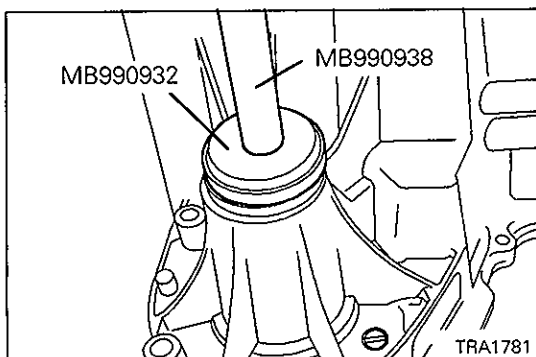

▶B◄ OIL SEAL INSTALLATION

- (1) Use the special tools to install the oil seal on the transfer case.

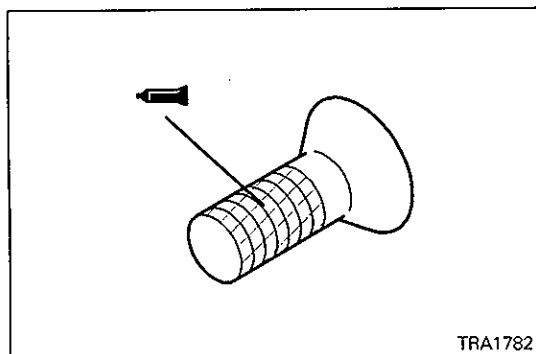

▶C◄ REAR BEARING RETAINER / FRONT BEARING RETAINER INSTALLATION

- (1) The bolts used for mounting the rear bearing retainer and front bearing retainer are pre-coated ones. When they are to be reused, apply sealant to the threaded portion before installation.

Specified sealant:

3M STUD Locking No. 4170 or equivalent

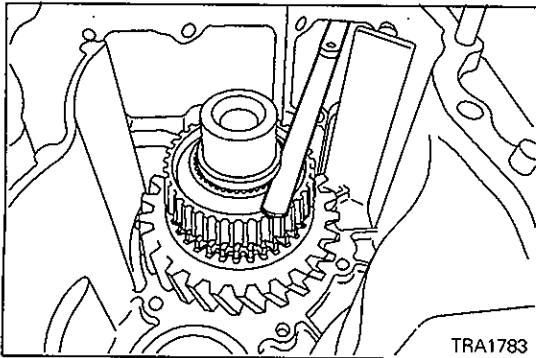

◆D◆ SNAP RING INSTALLATION

- (1) Select a proper snap ring so that the end play of the high/low clutch hub will have the standard value, and install the snap ring on the transfer drive shaft.

Standard value: 0 – 0.08 mm (0 – 0.003 in.)

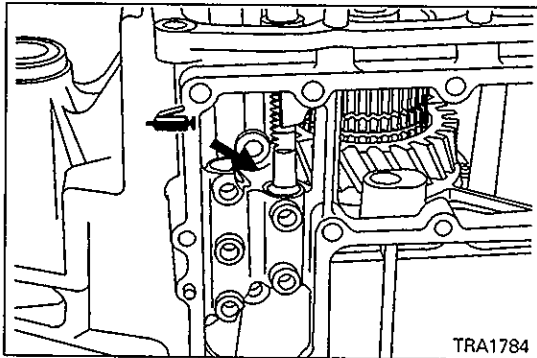

◆E◆ HIGH/LOW SHIFT FORK / HIGH/LOW CLUTCH SLEEVE INSTALLATION

- (1) Apply grease to the high/low shift fork shaft inserting portion, and install the high/low shift fork and high/low clutch sleeve in combined state in the transfer case.

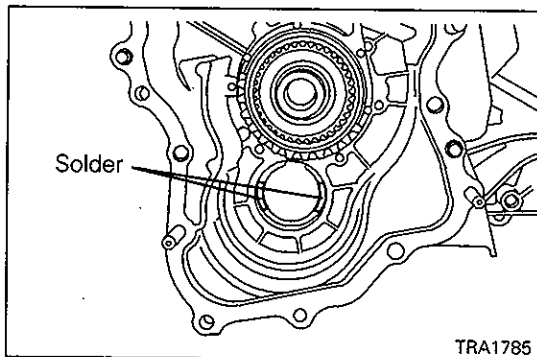

◆F◆ SPACER INSTALLATION

- (1) Put pieces of solder (approx. 10mm (0.4 in.) long and 1.6mm (0.06 in.) in diameter) at the illustrated positions of the transfer case.
- (2) Install the countershaft gear and transfer case plate and tighten the bolts to the specified torque.
- (3) If the pieces of solder are not crushed, put thicker pieces of solder and perform Steps 1 and 2.

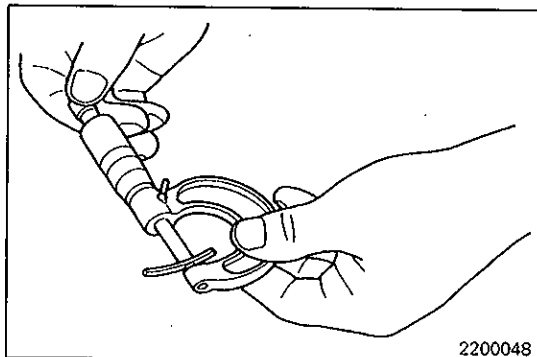

- (4) Measure the thickness of the crushed pieces of solder with a micrometer, and select a spacer of proper thickness so that the end play will have the standard value.

Standard value: 0 – 0.15 mm (0 – 0.006 in.)

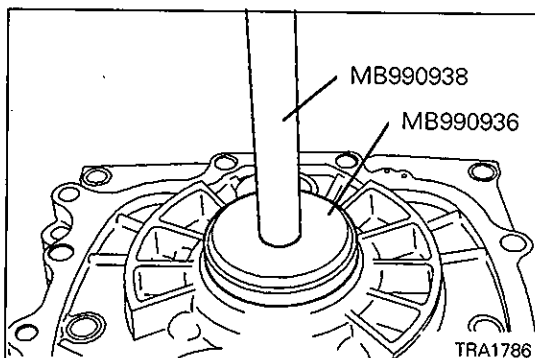

◆G◆ OIL SEAL INSTALLATION

- (1) Use the special tools to install the oil seal on the transfer case plate.

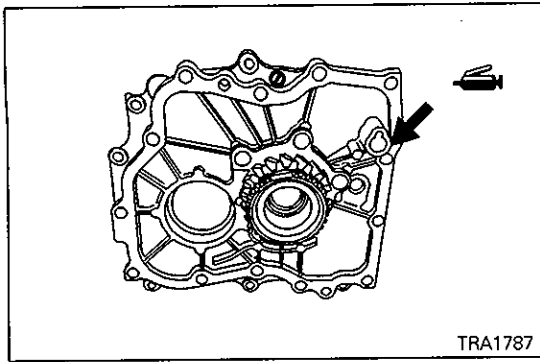

▶H▶ TRANSFER CASE PLATE INSTALLATION

- (1) Apply grease to the illustrated position of the high/low shift rail inserting portion of the transfer case plate.

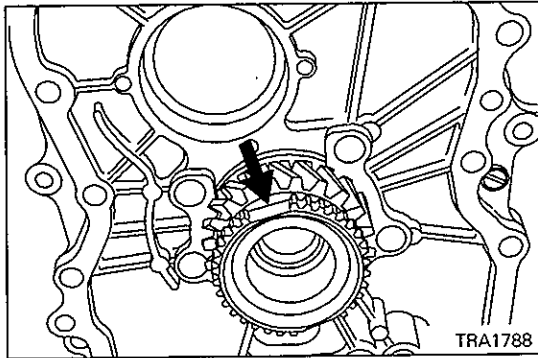

- (2) Face the notched portion of the input gear in the illustrated direction (in the direction of the countershaft gear bearing hole).

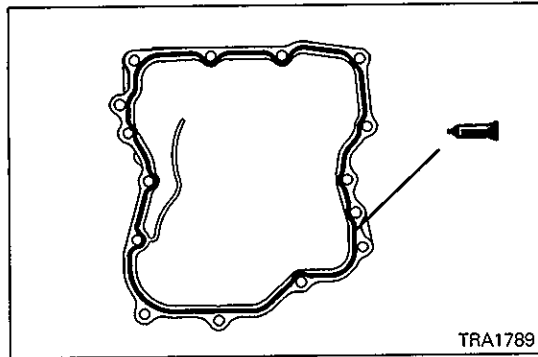

- (3) Apply sealant to the illustrated position of the transfer case.

Specified sealant:

Mitsubishi genuine sealant Part No. MD997740 or equivalent

Caution

- Squeeze sealant out evenly to make sure that it is not broken or excessively supplied.

- (4) While making sure that the notched portion of the input gear positioned in Step 2 is in alignment with the gear portion of the countershaft, install the transfer case plate.

Caution

- If the sub gear does not readily come in mesh with the countershaft gear, rotate the transfer drive shaft, etc. to securely engage it.

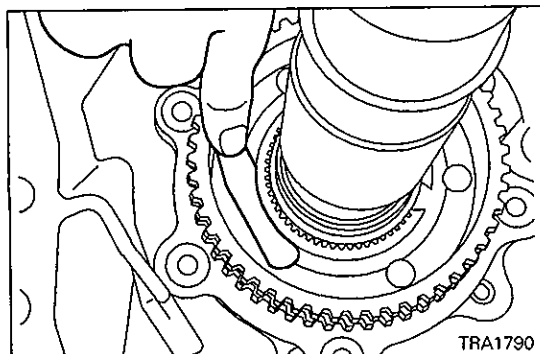

▶I▶ SNAP RING INSTALLATION

- (1) Select a proper snap ring so that the end play of the differential lock hub will have the standard value, and install it on the transfer drive shaft.

Standard value: 0 – 0.08 mm (0 – 0.003 in.)

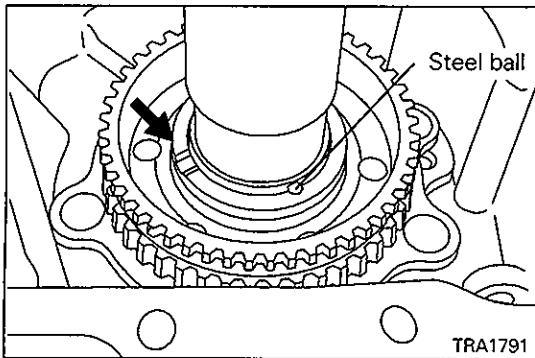

◆J◆ STEEL BALL / SPACER INSTALLATION

- (1) Install the steel ball in the illustrated position of the transfer drive shaft and install the spacer with its oil groove toward the chain cover.

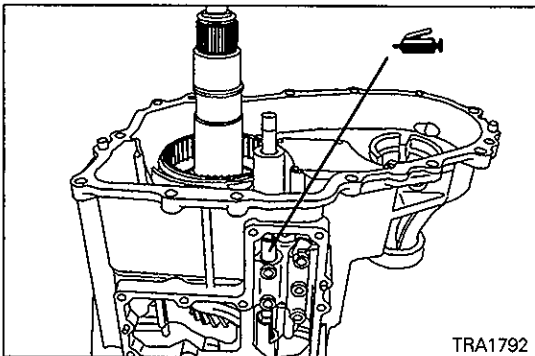

◆K◆ 2-4WD SHIFT FORK / 2-4WD CLUTCH SLEEVE INSTALLATION

- (1) Apply grease to the 2-4WD shift fork shaft inserting portion and install the 2-4WD shift fork and 2-4WD clutch sleeve in combined state in the transfer case.

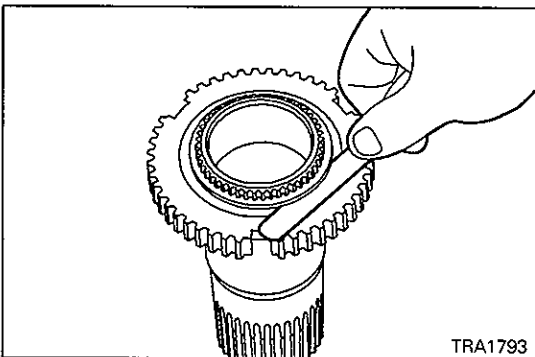

◆L◆ SUN GEAR / 2-4WD CLUTCH HUB AND SNAP RING INSTALLATION

- (1) Install the 2-4WD clutch hub on the sun gear.
- (2) Select a proper snap ring so that the end play of the 2-4WD clutch hub will have the standard value, and install it on the sun gear.

Standard value: 0 – 0.08 mm (0 – 0.003 in.)

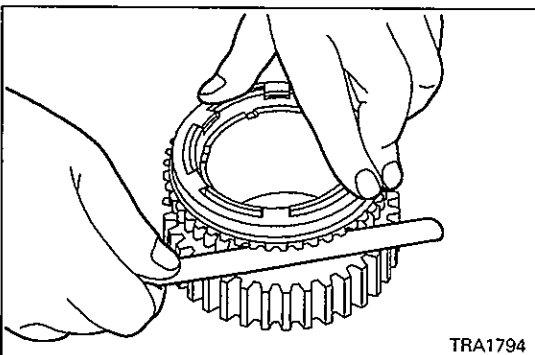

◆M◆ SYNCHRONIZER OUTER RING / SYNCHRONIZER CONE / SYNCHRONIZER INNER RING INSTALLATION

- (1) Combine the synchronizer outer ring, synchronizer cone and synchronizer inner ring, press them against the drive sprocket, and measure the dimension shown in the illustration.

Limit value: 0.3 mm (0.012 in.)

- (2) If the dimension is out of the limit value, replace them with a synchronizer ring set.
- (3) Apply gear oil to the synchronizer outer ring and synchronizer inner ring.
- (4) Line up the notched portion of the 2-4WD clutch hub with the projecting portion of the synchronizer ring and install the ring on the 2-4WD clutch hub.

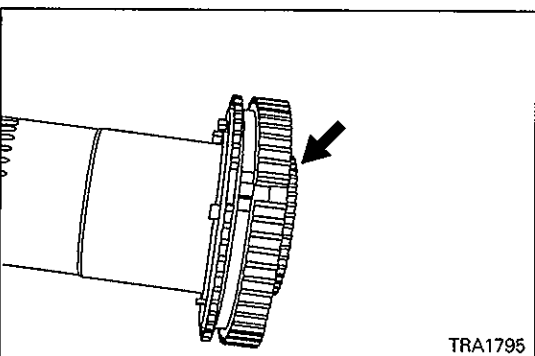

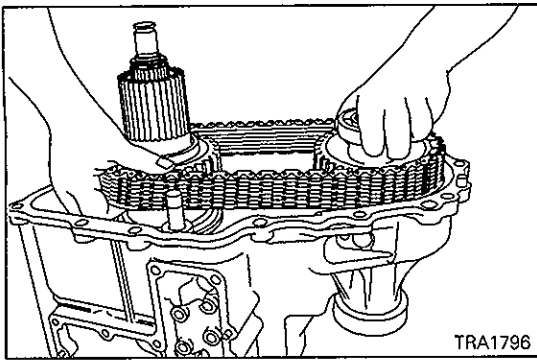

◆N◆ DRIVE SPROCKET / FRONT OUTPUT SHAFT / CHAIN INSTALLATION

- (1) Set the chain in mesh with the drive sprocket and front output shaft sprocket and install them in the transfer case.

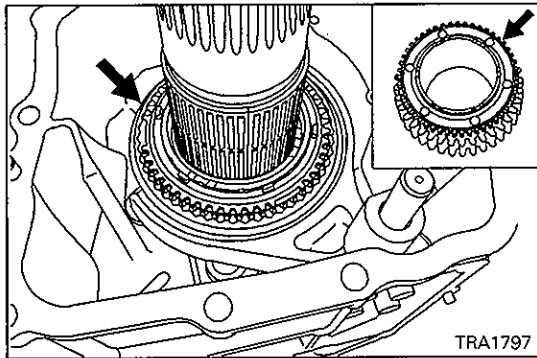

- (2) Install the drive sprocket so that its illustrated holes will match the projecting portions of the synchronizer cone.

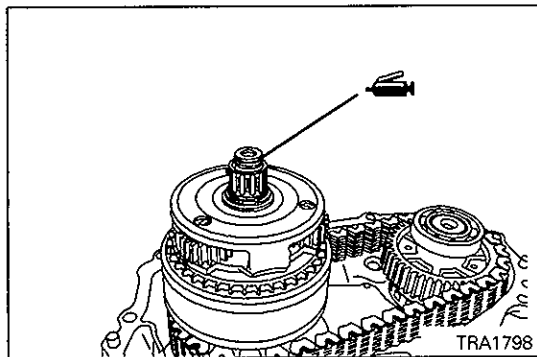

◆O◆ REAR OUTPUT SHAFT INSTALLATION

- (1) Apply grease to the O-ring at the illustrated position and install the rear output shaft.

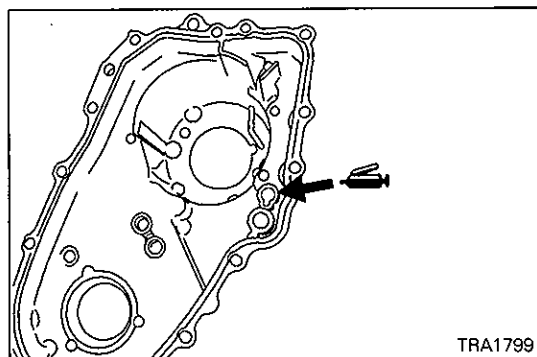

◆P◆ CHAIN COVER INSTALLATION

- (1) Apply grease to the indicated 2-4WD shift rail inserting portion.

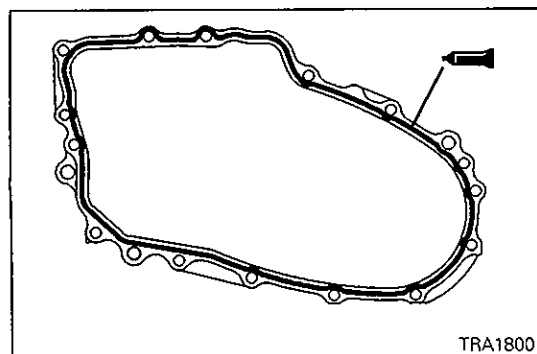

- (2) Apply a bead of sealant to the illustrated position of the chain cover.

Specified sealant:

Mitsubishi genuine sealant Part No. MD997740 or equivalent

Caution

- Squeeze the sealant out evenly to make sure that it is not broken or excessively supplied.

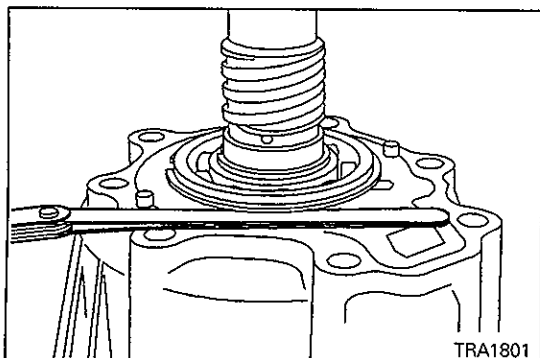

◆Q◆ SNAP RING ISNTALLATION

- (1) Install the snap ring in the bearing groove of the rear output shaft.
- (2) With the rear output shaft pressed against the chain cover, measure the clearance between the chain cover and snap ring.
- (3) Select a snap ring whose thickness is the dimension of the measured clearance plus the standard value.

Standard value: 0.12 – 0.24 mm (0.005 – 0.009 in.)

- (4) Remove the snap ring from the bearing groove of the rear output shaft, install the selected snap ring, and reinstall the removed snap ring in the bearing groove of the rear output shaft.

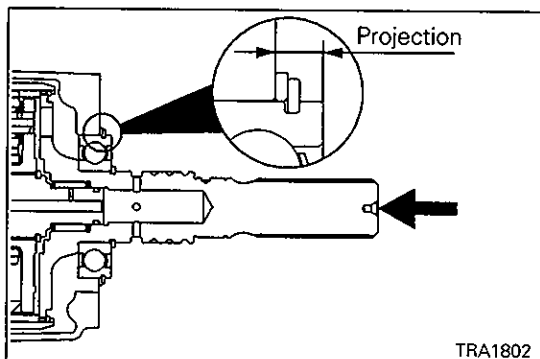

◆R◆ SPACER INSTALLATION

- (1) With the rear output shaft pressed toward the chain cover, measure the projection of the bearing from the chain cover.

Caution

- Measure the projection with the snap ring installed.

- (2) Measure the dimension of the rear cover concave portion at the illustrated position.
- (3) Subtract the measured value in Step 1 from the measured value in Step 2 to calculate the clearance between the bearing and rear cover. Select a proper spacer so that the clearance will have the standard value.

Standard value: 0 – 0.12 mm (0 – 0.05 in.)

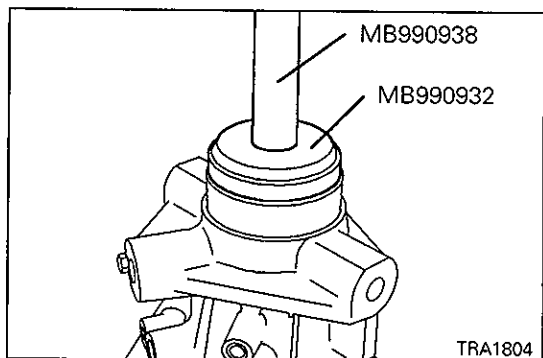
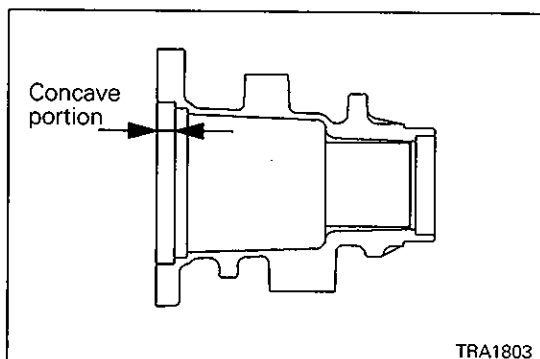

◆S◆ OIL SEAL INSTALLATION

- (1) Use the special tools to install the oil seal in the rear cover.

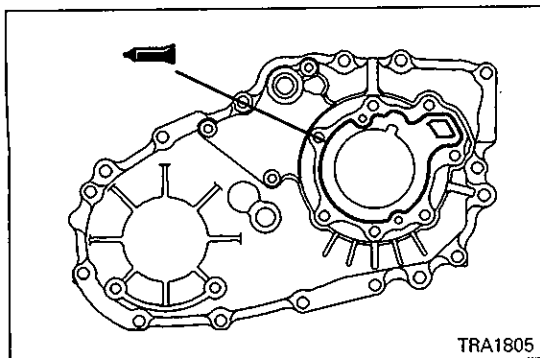

▶T◀ REAR COVER INSTALLATION

- (1) Apply sealant to the illustrated position of the chain cover.

Specified sealant:

Mitsubishi genuine sealant Part No. MD997740 or equivalent

Caution

- Squeeze the sealant out evenly to make sure that it is not broken or excessively supplied.

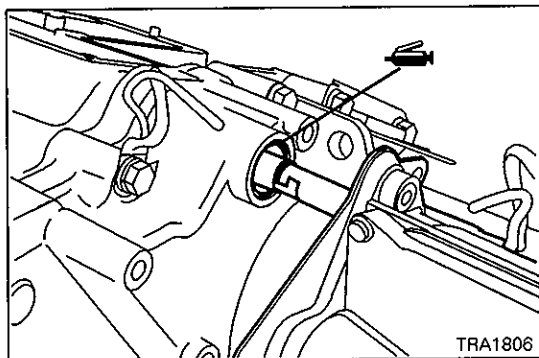

▶U◀ MAIN SHIFT RAIL / ACTUATOR INSTALLATION

- (1) Apply grease to the O-ring.
- (2) Combine the main shift rail key with actuator key and insert them in the transfer case.

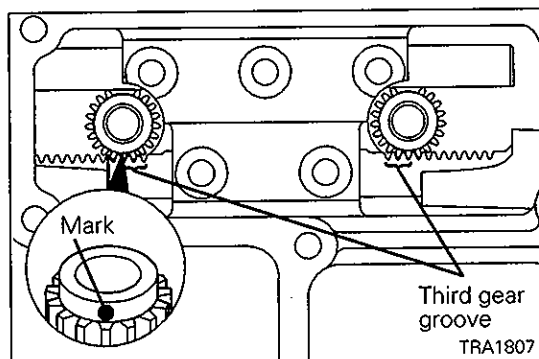

▶V◀ SHIFT RAIL DRIVE GEAR INSTALLATION

- (1) Install the shift rail drive gear with its marked tooth in mesh with the third gear groove of each shift rail.

8. TRANSFER CASE PLATE <V5M31> DISASSEMBLY AND REASSEMBLY

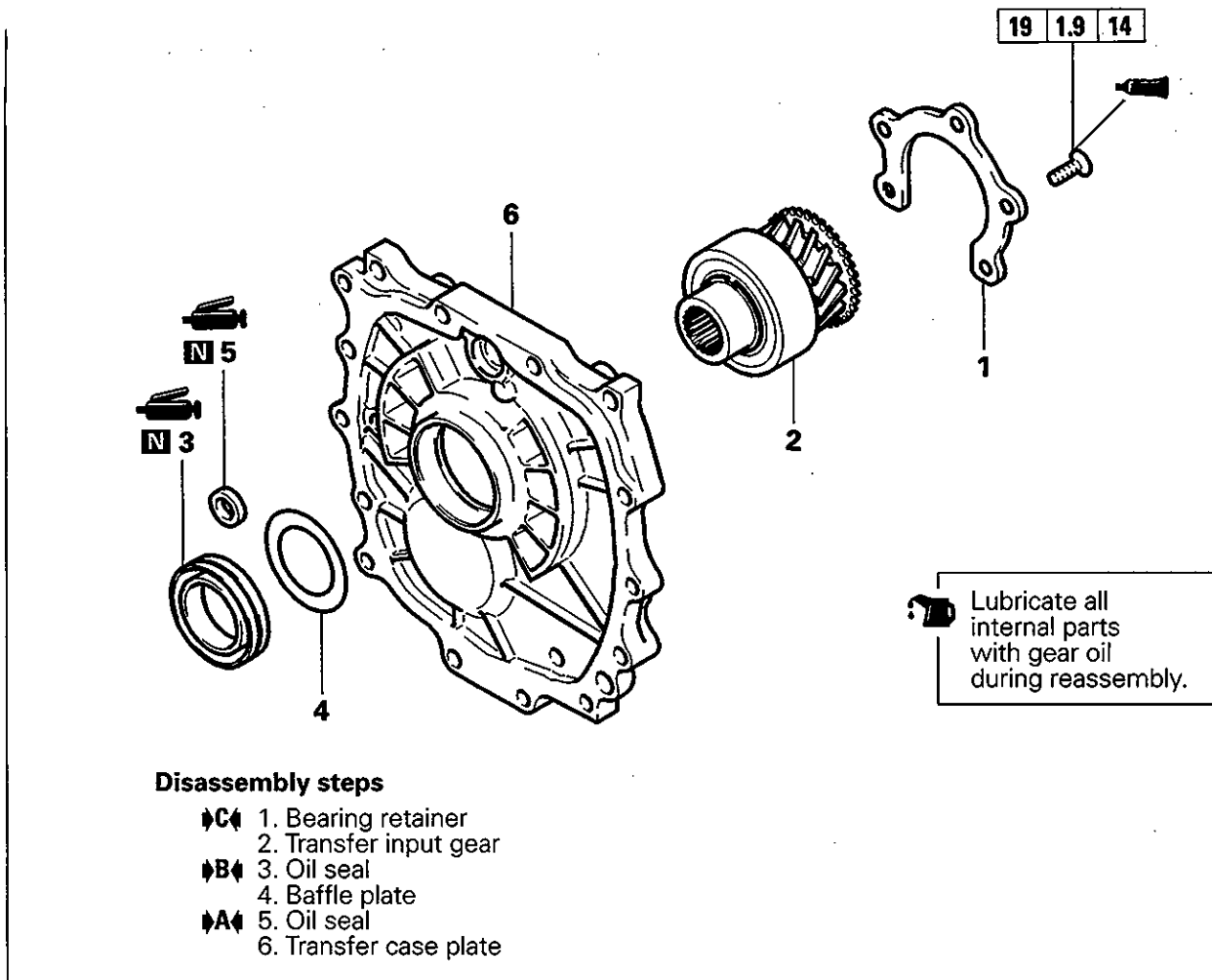

TRM0500

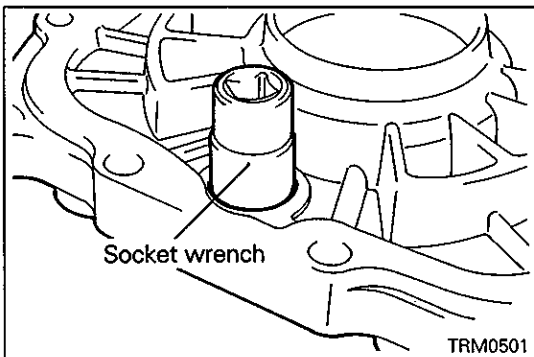

REASSEMBLY SERVICE POINTS

▶A▶ OIL SEAL INSTALLATION

- (1) Use a socket wrench or the like to install the oil seal. After installing, apply grease to the lip of the oil seal.

Specified grease:

Mitsubishi genuine grease Part No. 0101011 or equivalent

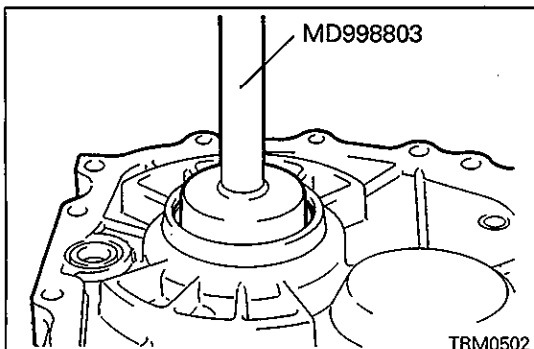

▶B▶ OIL SEAL INSTALLATION

- (1) After installation, apply grease to the lip of the oil seal.

Specified grease:

Mitsubishi genuine grease Part No. 0101011 or equivalent

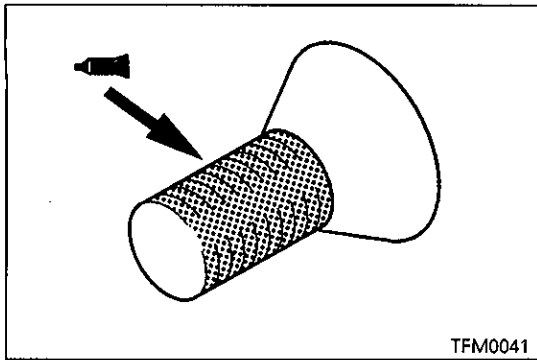
**⇄C⇄ BEARING RETAINER INSTALLATION**

- (1) The rear bearing mounting bolt is a precoated one. When it is to be reused, apply sealant beforehand.

Specified sealant:

3M STUD Locking No. 4170 or equivalent

9. TRANSFER INPUT GEAR <V5M31 – PART TIME 4WD AND SUPER SELECT 4WD>

DISASSEMBLY AND REASSEMBLY

 Apply gear oil to all moving parts before installation.

Disassembly steps

- ▶C▶ 1. Snap ring
- ◁A▶▶B▶ 2. Ball bearing
- ▶A▶ 3. Snap ring*
- ▶A▶ 4. Cone spring*
- 5. Sub gear*
- 6. Transfer input gear

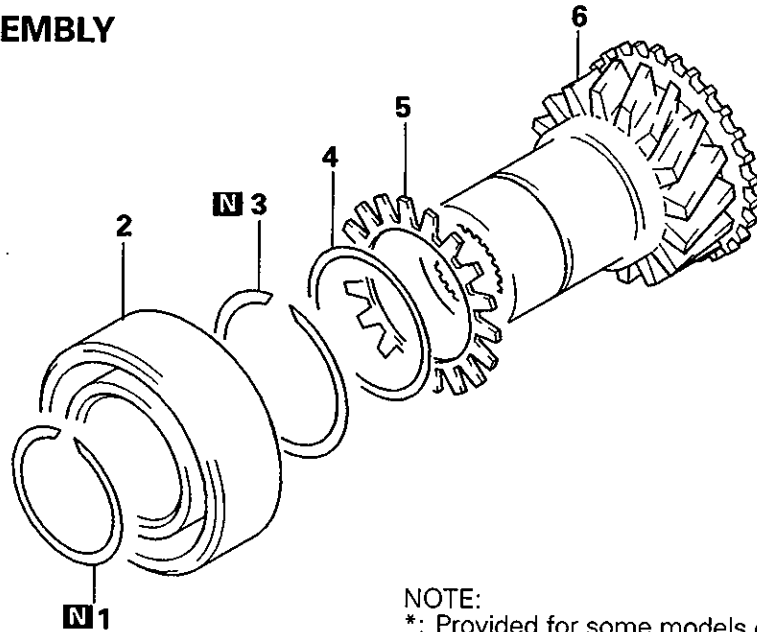

NOTE:
 *: Provided for some models only

TRM0503

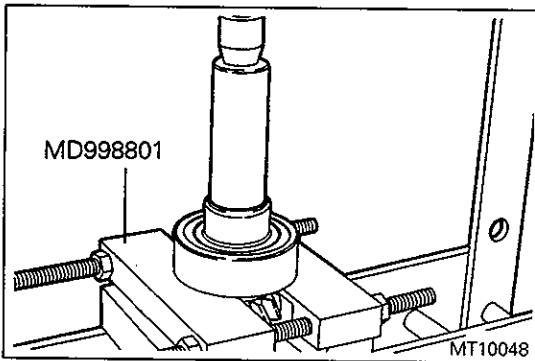

DISASSEMBLY SERVICE POINT

- ◁A▶ BALL BEARING REMOVAL

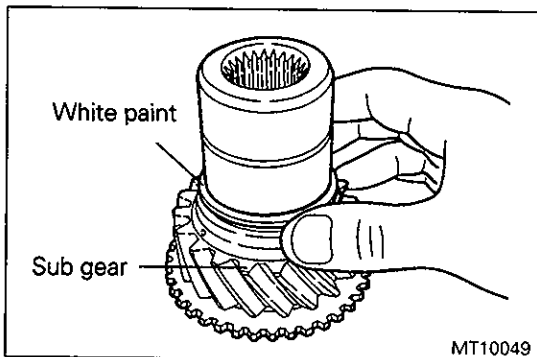

REASSEMBLY SERVICE POINTS

- ▶A▶ CONE SPRING INSTALLATION

(1) Install the cone spring with the white paint side up.

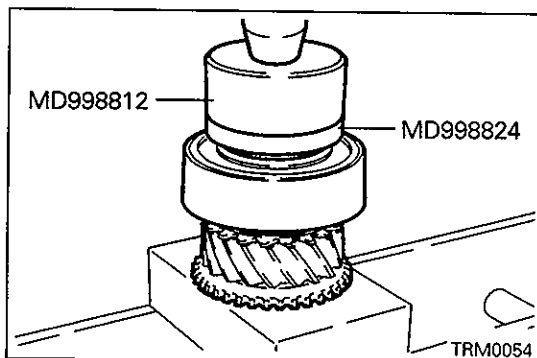

- ▶B▶ BALL BEARING INSTALLATION

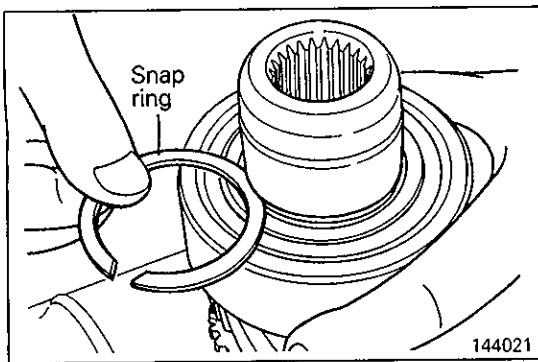
**◆C◆ SNAP RING INSTALLATION**

- (1) Select a snap ring which adjusts the end play of the input gear bearing to the standard value shown below:

Standard value: 0 – 0.06 mm (0 – 0.0024 in.)

9a. TRANSFER INPUT GEAR <V5M31 – SUPER SELECT 4WD II> DISASSEMBLY AND REASSEMBLY

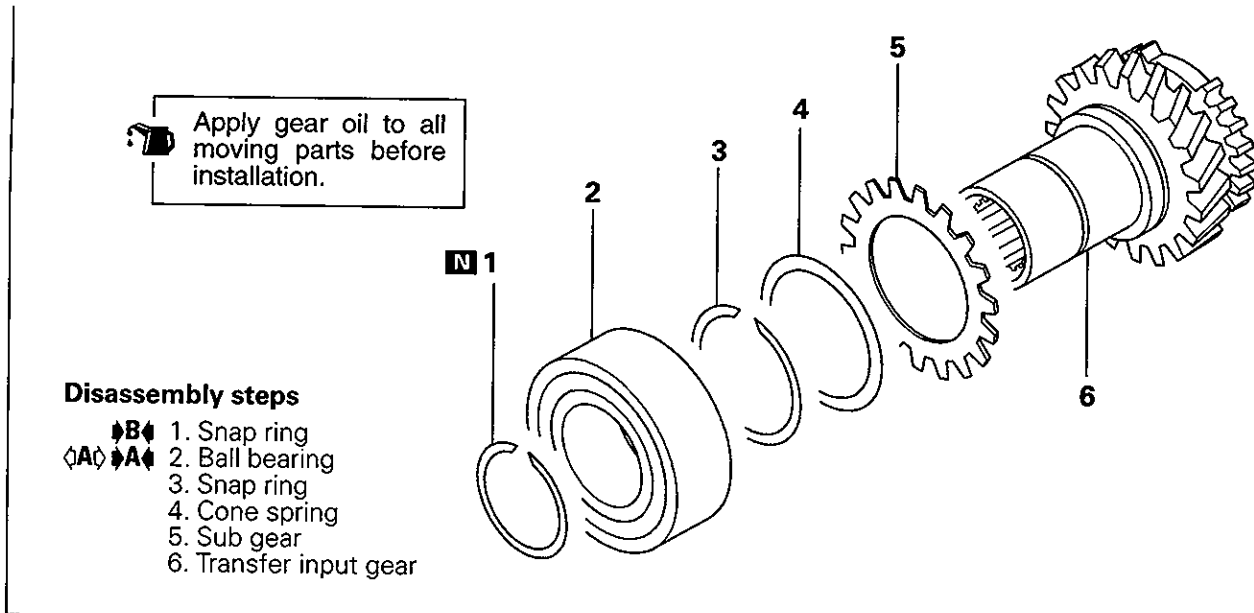

TRA1822

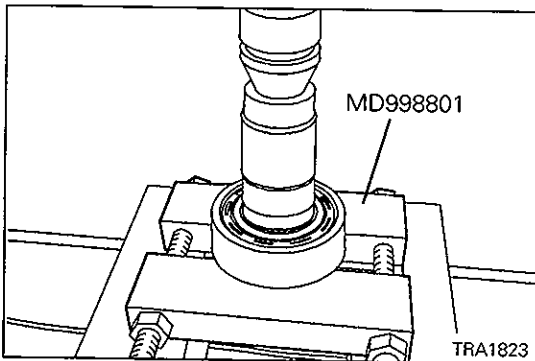

DISASSEMBLY SERVICE POINTS

◇A◇ BALL BEARING REMOVAL

- (1) Use the special tool to remove the ball bearing.

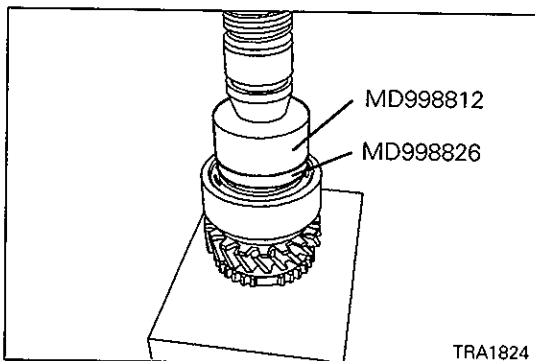

REASSEMBLY SERVICE POINTS

◆A◆ BALL BEARING INSTALLATION

- (1) Use the special tool to install the ball bearing.

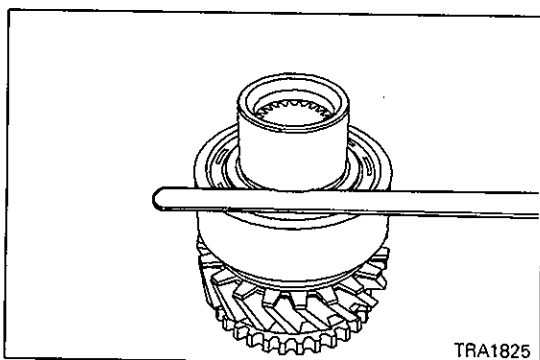

◆B◆ SNAP RING INSTALLATION

- (1) Select and install a proper snap ring so that the end play of the transfer input gear bearing will have the standard value.

Standard value: 0 – 0.06 mm (0 – 0.024 in.)

10. COUNTERSHAFT GEAR <V5M31 – PART TIME 4WD AND SUPER SELECT 4WD>

DISASSEMBLY AND REASSEMBLY

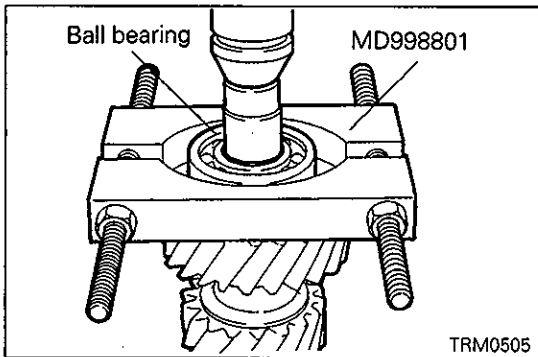
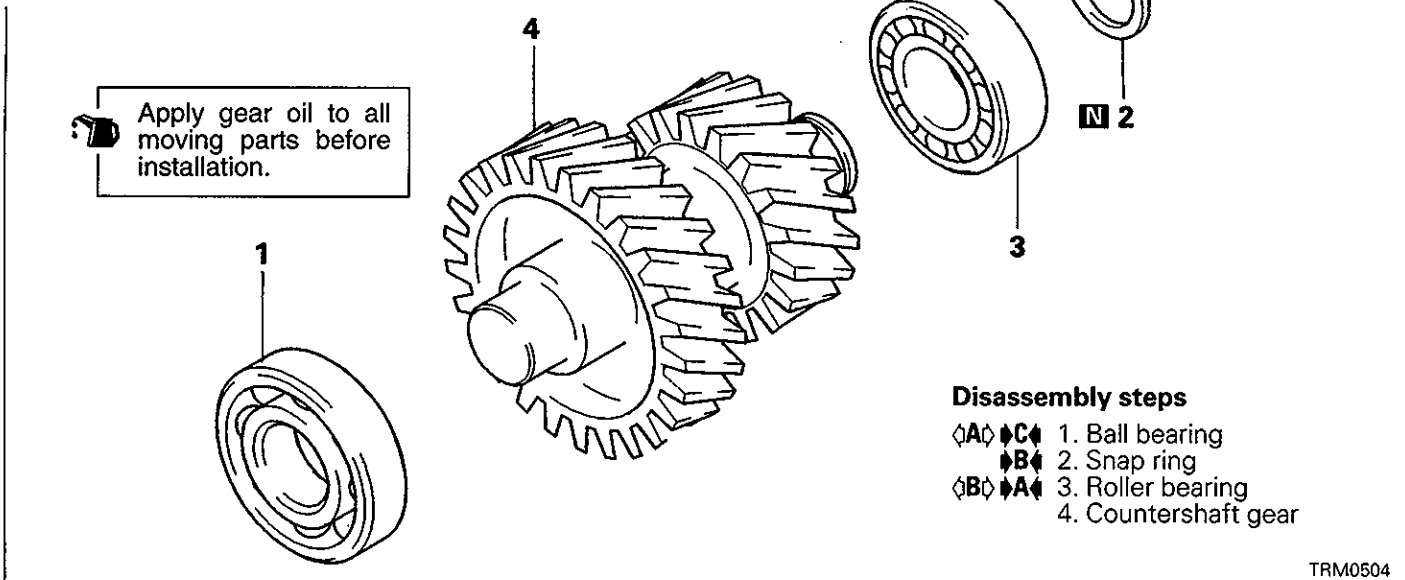

DISASSEMBLY SERVICE POINTS

◇A◇ BALL BEARING REMOVAL

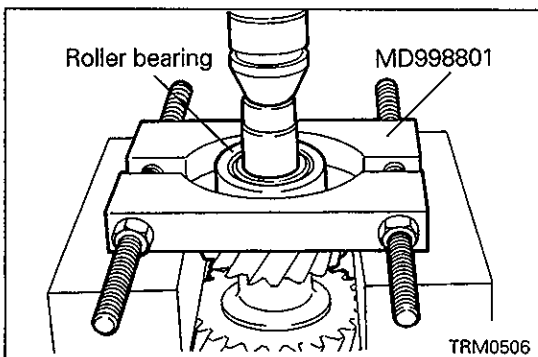

◇B◇ ROLLER BEARING REMOVAL

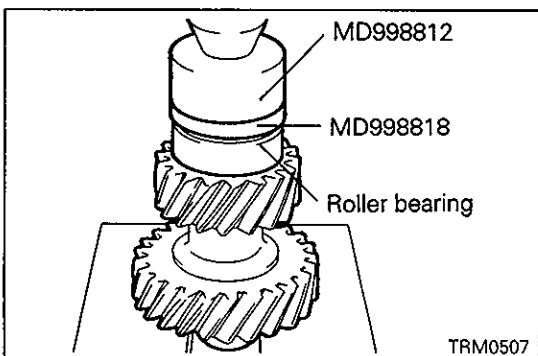

REASSEMBLY SERVICE POINTS

◇A◇ ROLLER BEARING INSTALLATION

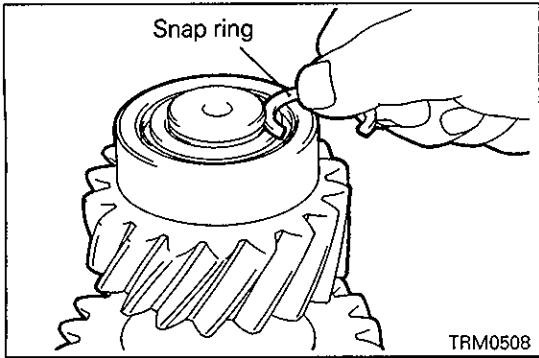

◆B◆ SNAP RING INSTALLATION

- (1) Select a snap ring that adjusts the end play of the countershaft gear roller bearing to the standard value shown below:
Standard value: 0 – 0.08 mm (0 – 0.0031 in.)

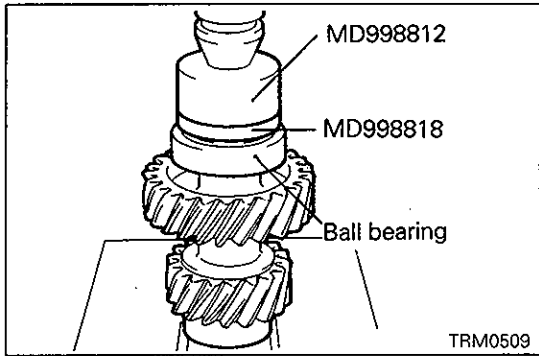

◆C◆ BALL BEARING INSTALLATION

10a. COUNTERSHAFT GEAR <V5M31 – SUPER SELECT 4WD II> DISASSEMBLY AND REASSEMBLY



Apply gear oil to all moving parts before installation.

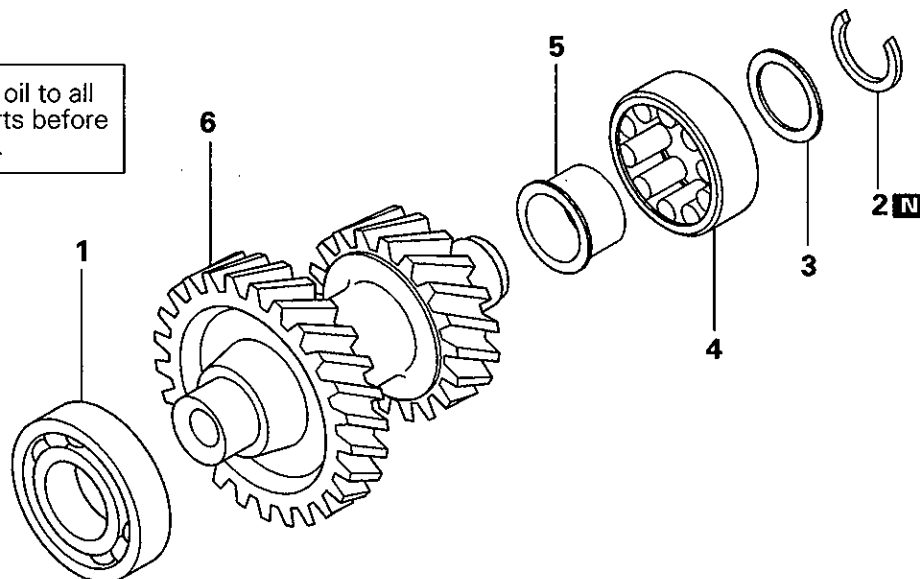

Disassembly steps

- ◁A▷ ▷C◁ 1. Ball bearing
- ▷B◁ ▷B◁ 2. Snap ring
- ◁B▷ ▷A◁ 3. Spacer

- ◁B▷ ▷A◁ 4. Roller bearing
- ◁B▷ ▷A◁ 5. Inner race
- ▷B◁ ▷A◁ 6. Countershaft gear

TRA1826

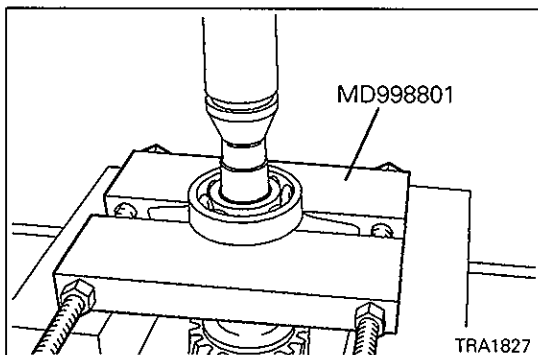

DISASSEMBLY SERVICE POINTS

◁A▷ BALL BEARING REMOVAL

- (1) Use the special tool to remove the ball bearing.

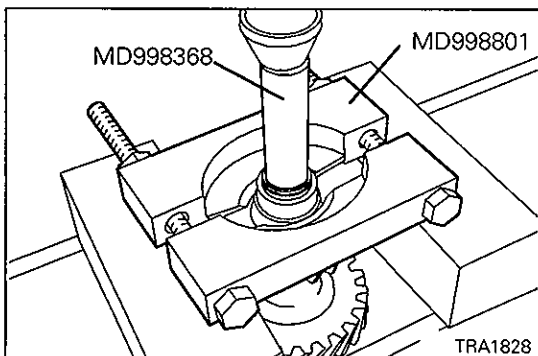

◁B▷ SPACER / ROLLER BEARING / INNER RACE REMOVAL

- (1) Remove the spacer and roller bearing.
- (2) Using the special tool, remove the inner race.

NOTE

The removal sequence of roller bearing parts vary depending on the direction that the roller bearing was installed. In some cases, the inner race, roller bearing and spacer may have to be simultaneously removed.

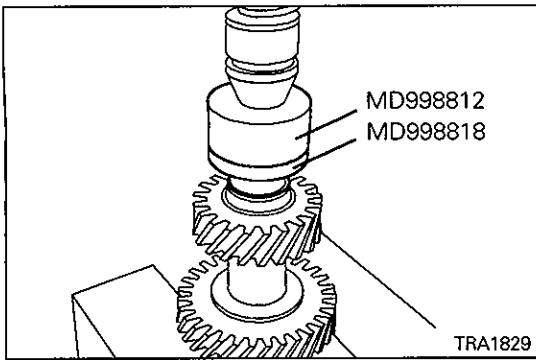
**REASSEMBLY SERVICE POINTS****▶A◀ INNER RACE / ROLLER BEARING / SPACER INSTALLATION**

- (1) Using the special tool, install the inner race.
- (2) Install the roller bearing and spacer.

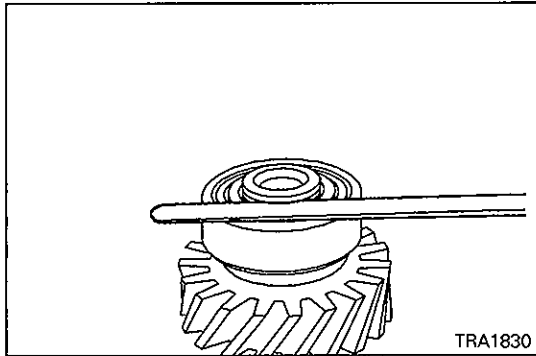
**▶B◀ SNAP RING INSTALLATION**

- (1) Select and install a proper snap ring so that the end play of the countershaft gear roller bearing will have the standard value.

Standard value: 0 – 0.08 mm (0 – 0.003 in.)

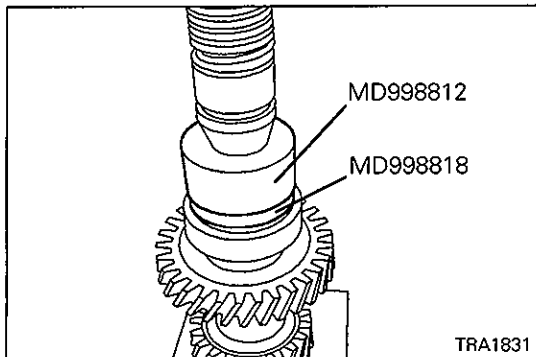
**▶C◀ BALL BEARING INSTALLATION**

- (1) Use the special tools to install the ball bearing.

11. H-L SHIFT FORK <V5M31 – PART TIME 4WD AND SUPER SELECT 4WD>

DISASSEMBLY AND REASSEMBLY

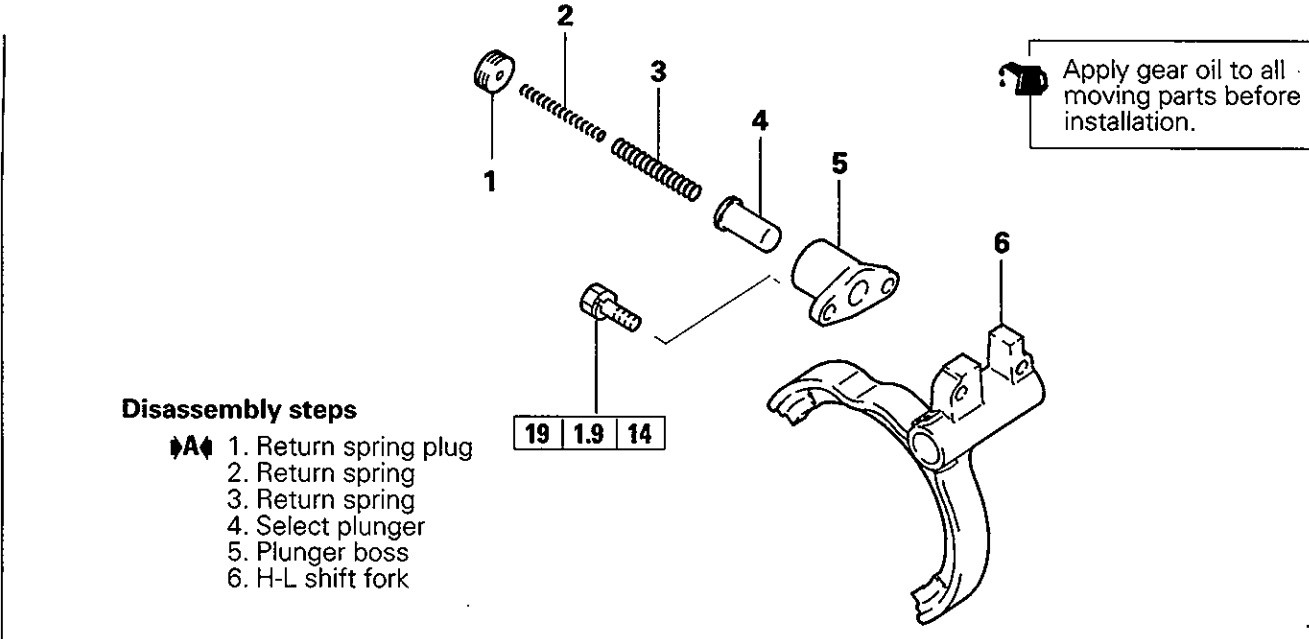

TRM0226

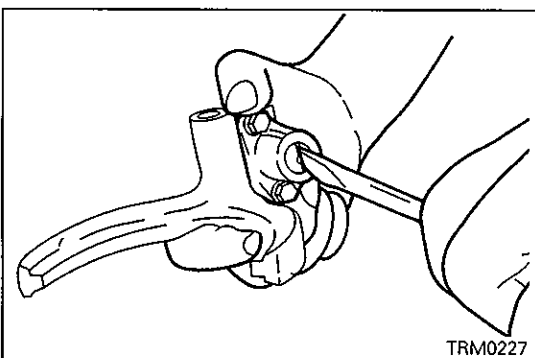

REASSEMBLY SERVICE POINT

▶▶ RETURN SPRING PLUG INSTALLATION

- (1) Thread the plug in until it is flush with the plunger boss end.

11a. SHIFT FORK AND SHIFT RAIL <V5M31 – SUPER SELECT 4WD II> DISASSEMBLY AND REASSEMBLY

 Apply gear oil to all moving parts before installation.

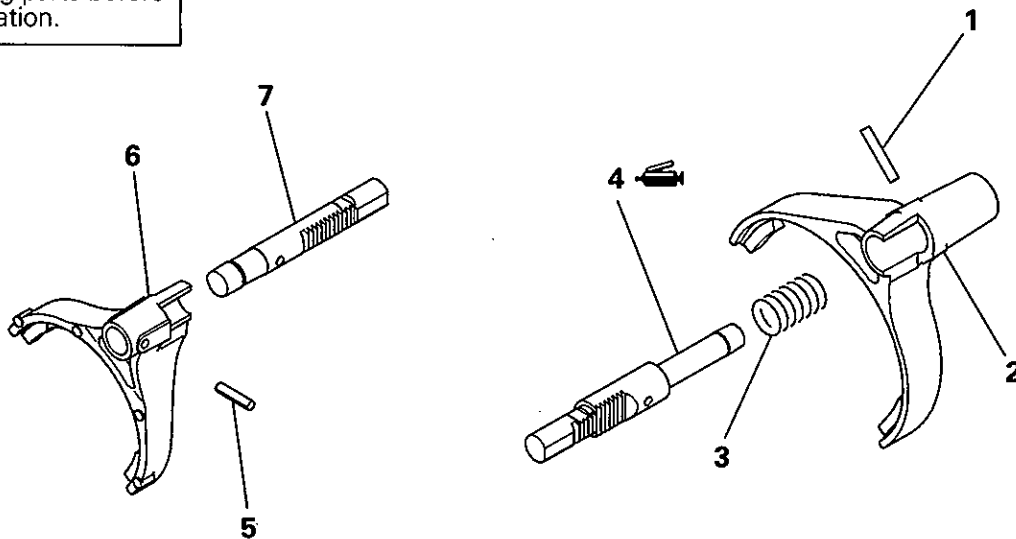

Disassembly steps

- ▶B 1. Spring pin
- ▶A 2. 2-4WD shift fork
- 3. Spring
- ▶A 4. 2-4WD shift rail

- ▶B 5. Spring pin
- ▶A 6. High/low shift fork
- ▶A 7. High/low shift rail

TRA1835

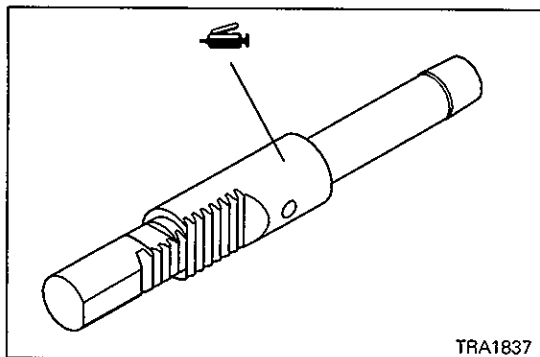

TRA1837

REASSEMBLY SERVICE POINTS

▶A SHIFT FORK / SHIFT RAIL INSTALLATION

- (1) Apply grease to the outer periphery of the shift fork mounting portion of the shift rail and then assemble the shift fork and shift rail.

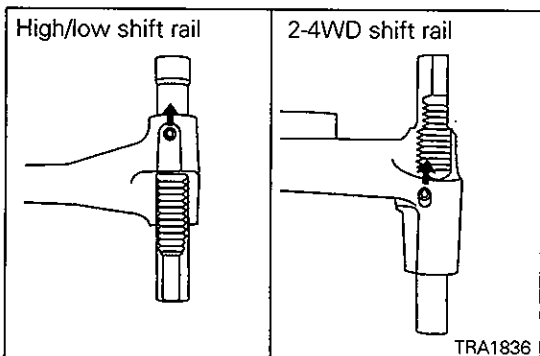

TRA1836

▶B SPRING PIN INSTALLATION

- (1) Install the spring pin with its split toward the forward end of the transfer.

NOTES

12.2-4WD SYNCHRONIZER <V5M31 – SUPER SELECT 4WD> DISASSEMBLY AND REASSEMBLY



Lubricate all internal parts with gear oil during reassembly.

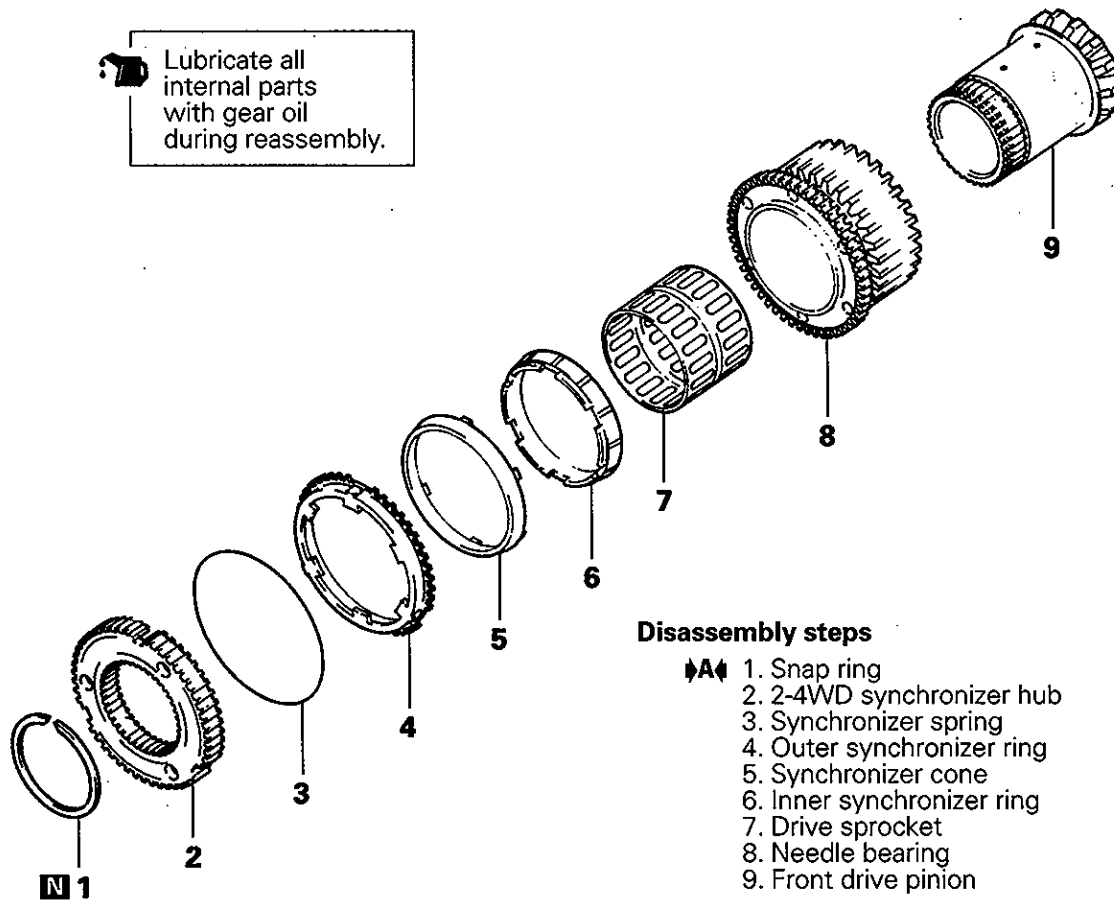

Disassembly steps

1. Snap ring
2. 2-4WD synchronizer hub
3. Synchronizer spring
4. Outer synchronizer ring
5. Synchronizer cone
6. Inner synchronizer ring
7. Drive sprocket
8. Needle bearing
9. Front drive pinion

TRA0307

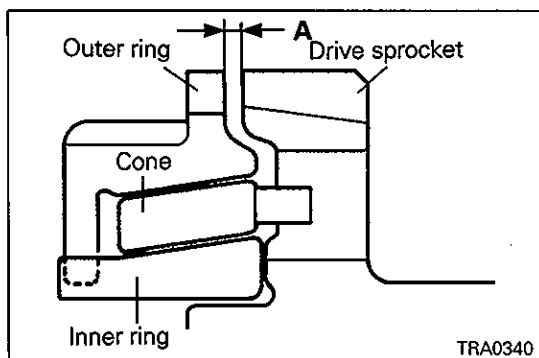

INSPECTION

SYNCHRONIZER RING, SYNCHRONIZER CONE

- (1) Combine the inner and outer synchronizer rings and cone with the drive sprocket and measure the dimension A in the illustration. If the dimension A is less than the limit, replace them as a set.

Limit: 0.3 mm (0.012 in.)

NOTE

Scratches may be found on the cone surface in the rotating direction. These are produced by the liners of the synchronizer rings and do not mean the malfunction. Therefore, the parts need not be replaced if the above-mentioned clearance is satisfied.

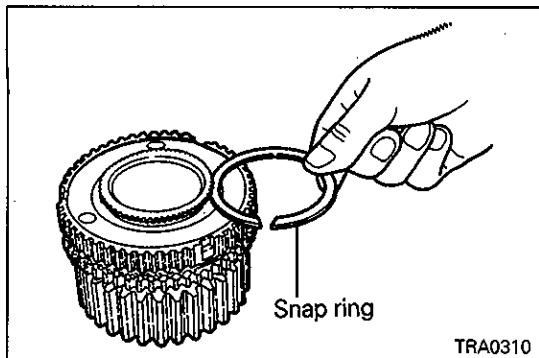

REASSEMBLY SERVICE POINT

▶A▶ SNAP RING INSTALLATION

- (1) Select a snap ring that will adjust the end play of the 2-4WD synchronizer hub to the standard value:

Standard value: 0 – 0.08 mm (0 – 0.0031 in.)

13. CENTER DIFFERENTIAL CASE <V5M31 – SUPER SELECT 4WD> DISASSEMBLY AND REASSEMBLY

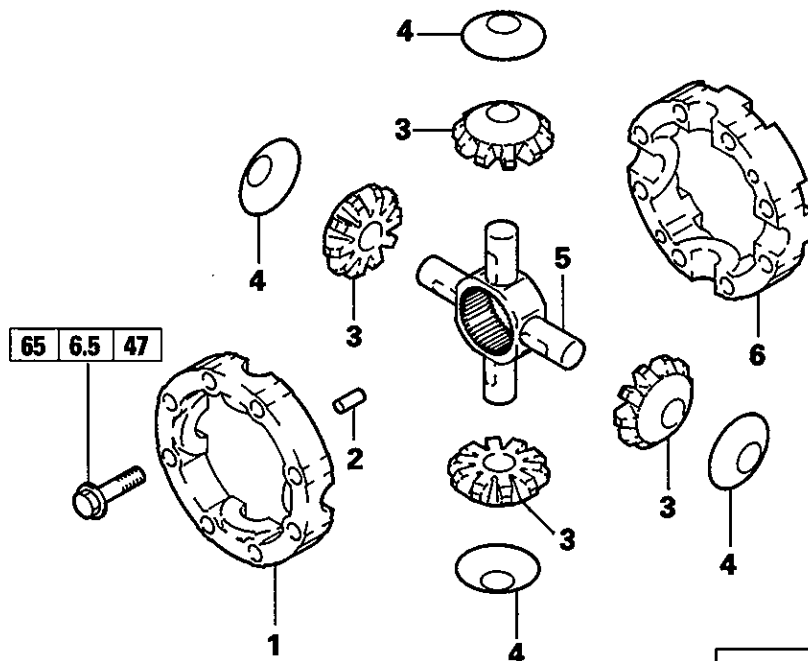

Disassembly steps

1. Center differential case front
2. Dowel pin
3. Pinion
4. Thrust washer
5. Pinion shaft
6. Center differential case rear

 Lubricate all internal parts with gear oil during reassembly.

TRA0305

NOTES

14. REAR OUTPUT SHAFT <V5M31 – SUPER SELECT 4WD> DISASSEMBLY AND REASSEMBLY

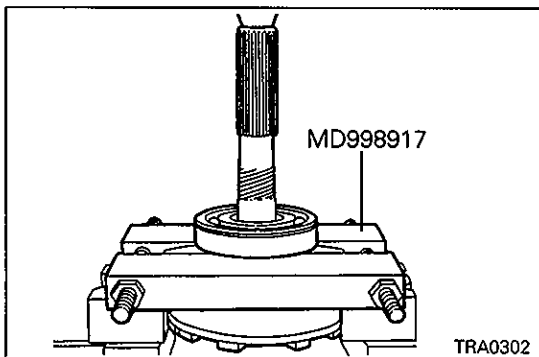
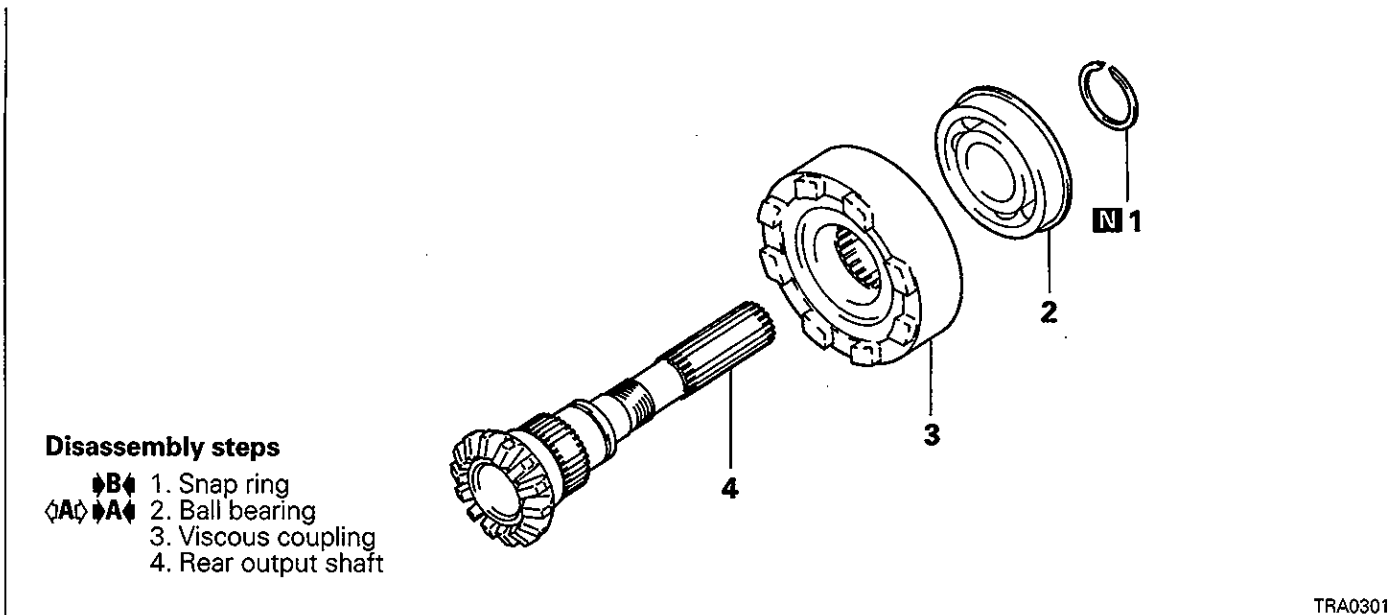

DISASSEMBLY SERVICE POINT

◀A▶ **BALL BEARING REMOVAL**

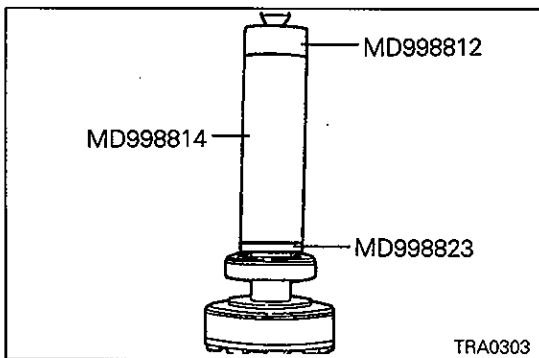

REASSEMBLY SERVICE POINTS

▶A▶ **BALL BEARING INSTALLATION**

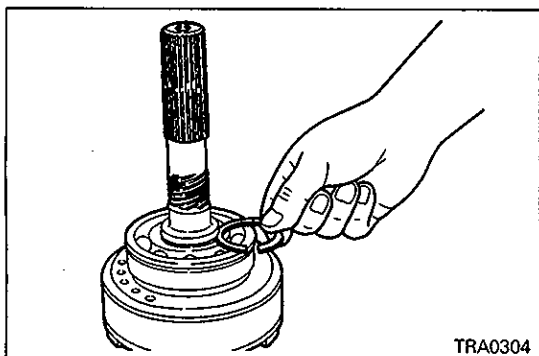

▶B▶ **SNAP RING INSTALLATION**

(1) Select a snap ring that will adjust the end play of the rear output shaft ball bearing to the standard value:

Standard value: 0 – 0.08 mm (0 – 0.0031 in.)

14a. REAR OUTPUT SHAFT <V5M31 – SUPER SELECT 4WD II>



Apply gear oil to all moving parts before installation.

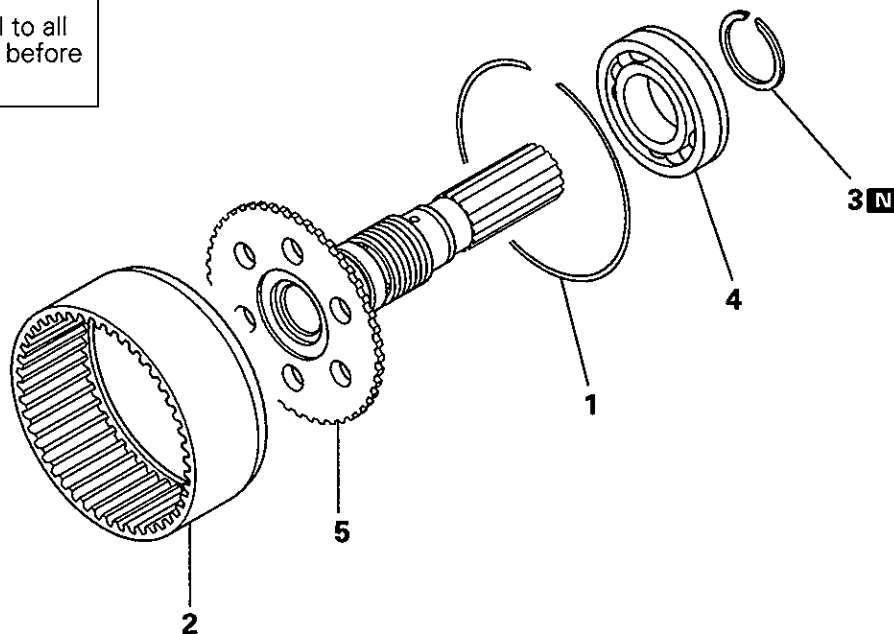

Disassembly steps

- ↗C↖ 1. Snap ring
- 2. Annulus gear
- ↗B↖ 3. Snap ring
- ↔A↔↗A↖ 4. Ball bearing
- 5. Rear output shaft

TRA1812

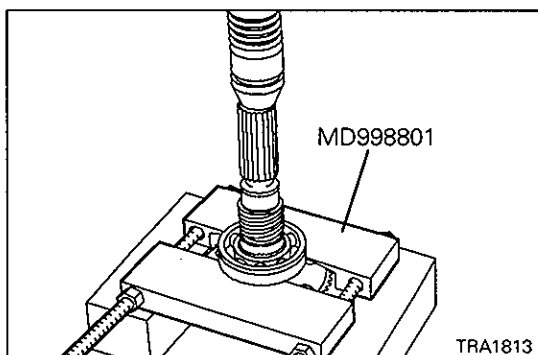

DISASSEMBLY SERVICE POINTS

↔A↔ BALL BEARING REMOVAL

- (1) Use the special tools to remove the ball bearing.

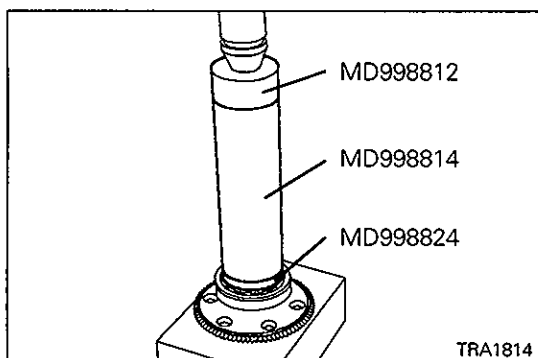

REASSEMBLY SERVICE POINTS

↗A↖ BALL BEARING INSTALLATION

- (1) Use the special tools to install the ball bearing.

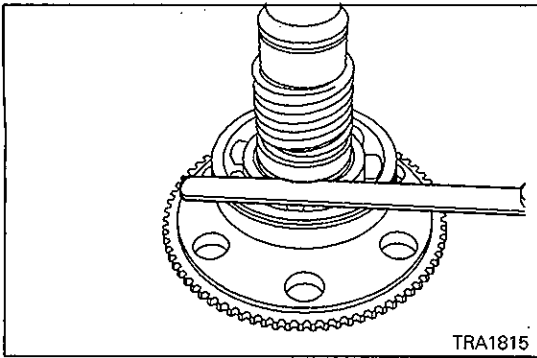
**◆B◆ SNAP RING INSTALLATION**

- (1) Select and install a proper snap ring so that the end play of the rear output shaft bearing will have the standard value.

Standard value: 0 – 0.08 mm (0 – 0.003 in.)

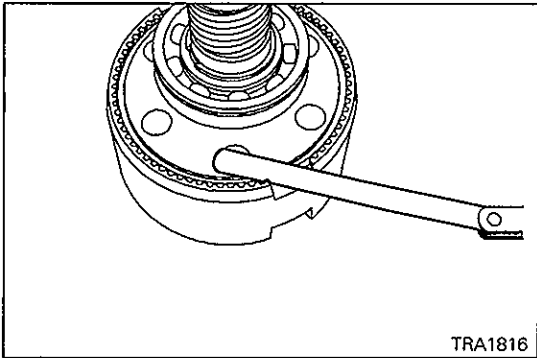
**◆C◆ SNAP RING INSTALLATION**

- (1) Select and install a proper snap ring so that the clearance between the annulus gear and rear output shaft will have the standard value.

Standard value: 0 – 0.08 mm (0 – 0.003 in.)

NOTES

15. REAR OUTPUT SHAFT <V5M31 – PART TIME 4WD>

DISASSEMBLY AND REASSEMBLY <V5M31-5>

Apply gear oil to all moving parts before installation.

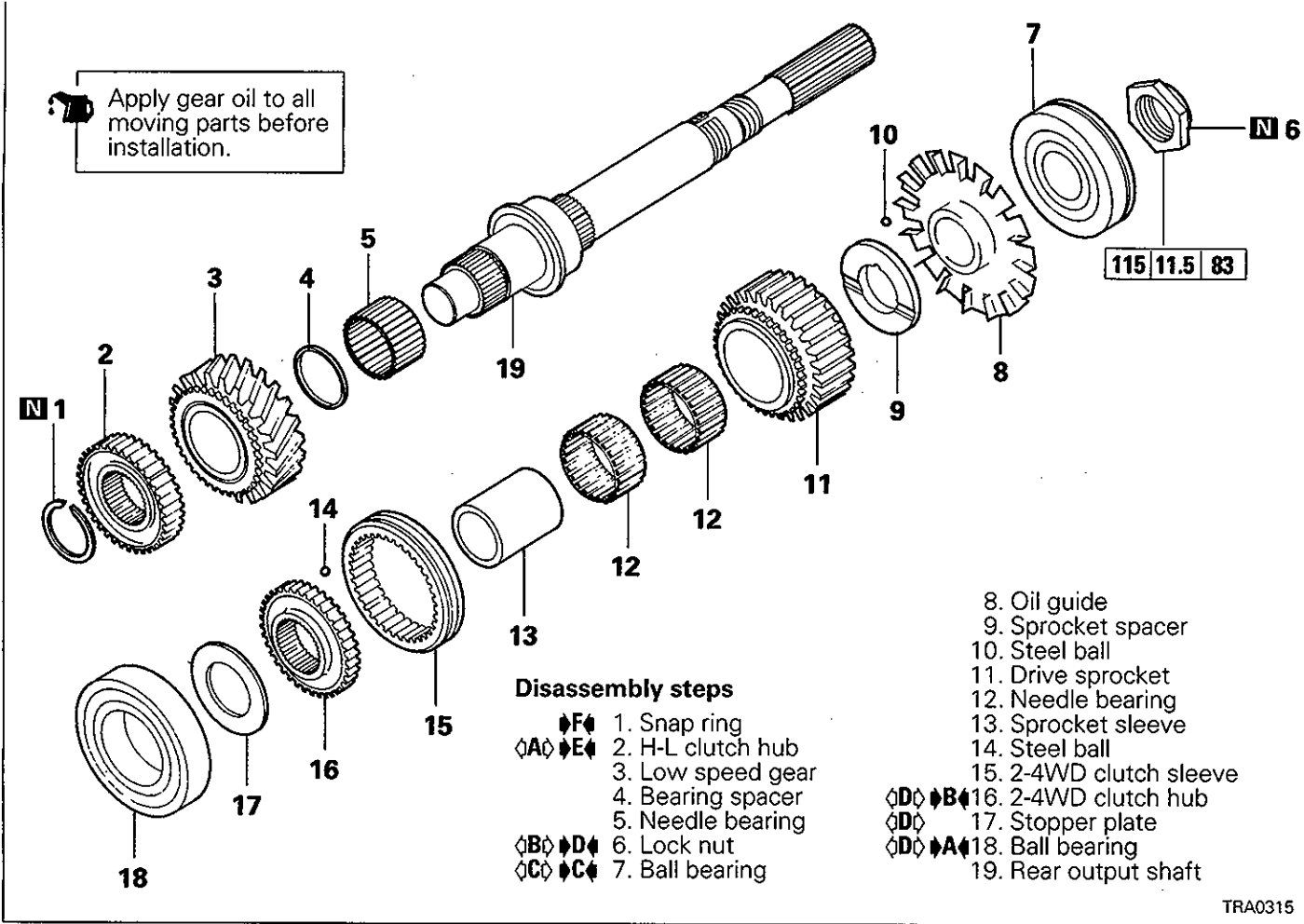

Disassembly steps

- ↕F↕ 1. Snap ring
- ↕A↕ ↕E↕ 2. H-L clutch hub
- 3. Low speed gear
- 4. Bearing spacer
- 5. Needle bearing
- ↕B↕ ↕D↕ 6. Lock nut
- ↕C↕ ↕C↕ 7. Ball bearing

- 8. Oil guide
- 9. Sprocket spacer
- 10. Steel ball
- 11. Drive sprocket
- 12. Needle bearing
- 13. Sprocket sleeve
- 14. Steel ball
- 15. 2-4WD clutch sleeve
- ↕D↕ ↕B↕ 16. 2-4WD clutch hub
- ↕D↕ 17. Stopper plate
- ↕D↕ ↕A↕ 18. Ball bearing
- 19. Rear output shaft

TRA0315

DISASSEMBLY AND REASSEMBLY <V5M31-6>

Apply gear oil to all moving parts before installation.

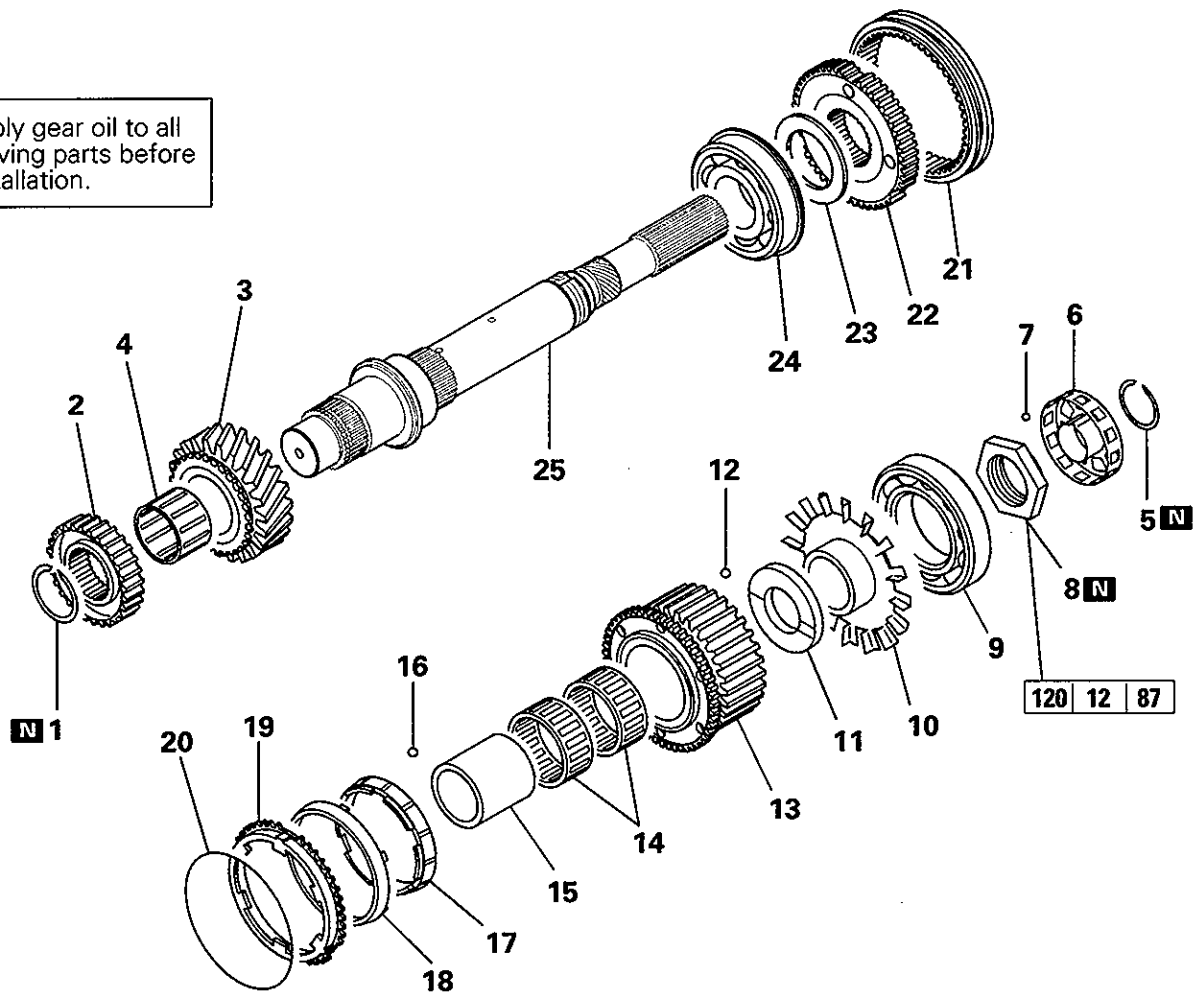

Disassembly steps

- | | | | |
|--------|------------------------|-----------------------------|------------------------|
| ◆F◆ | 1. Snap ring | 14. Needle bearing | |
| ◁A▷◆E◆ | 2. Clutch hub (H-L) | 15. Sprocket sleeve | |
| | 3. Low speed gear | 16. Steel ball | |
| | 4. Needle bearing | 17. Inner synchronizer ring | |
| | 5. Snap ring | 18. Synchronizer cone | |
| | 6. Rotor | 19. Outer synchronizer ring | |
| | 7. Steel ball | 20. Synchronizer spring | |
| ◆B◆◆D◆ | 8. Lock nut | 21. Clutch sleeve | |
| ◆C◆◆C◆ | 9. Radial ball bearing | ◆D◆◆B◆ | 22. Clutch hub (2-4WD) |
| | 10. Oil guide | ◆D◆ | 23. Stopper plate |
| | 11. Sprocket spacer | ◆D◆◆A◆ | 24. Ball bearing |
| | 12. Steel ball | | 25. Rear output shaft |
| | 13. Drive sprocket | | |

TRM1376

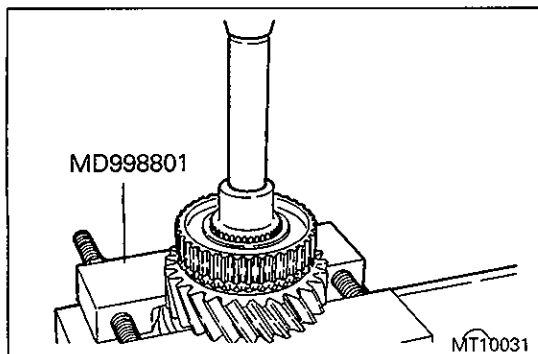

DISASSEMBLY SERVICE POINTS

◁A▷ H-L CLUTCH HUB REMOVAL

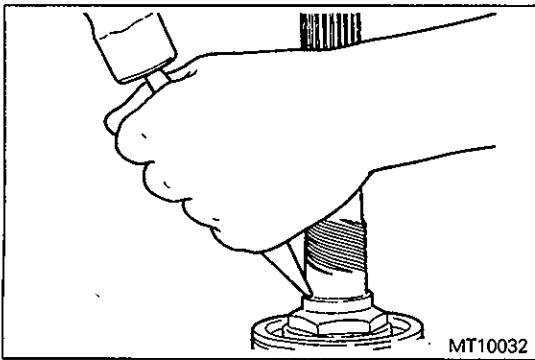

◁B▷ LOCK NUT REMOVAL

- (1) Clamp the drive sprocket in a vice with soft jaws attached.
- (2) Use a chisel and hammer to unstake the lock nut.

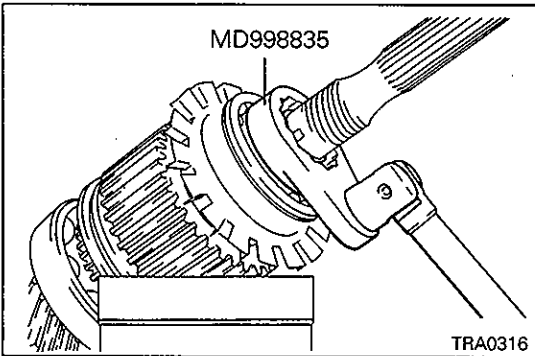

- (3) Fix the rear output shaft by putting the clutch sleeve in mesh with the drive sprocket.
- (4) Use the special tool to remove the lock nut.

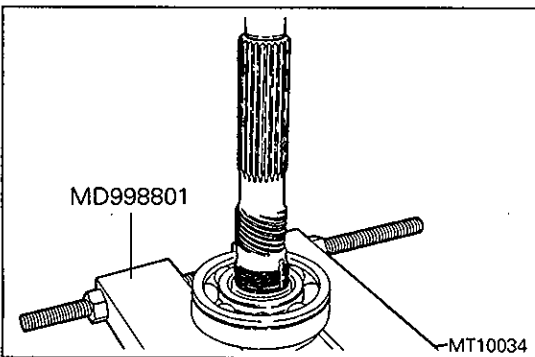

◁C▷ BALL BEARING REMOVAL

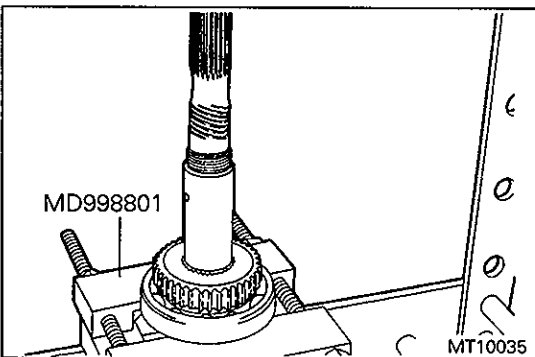

◁D▷ 2-4WD CLUTCH HUB / STOPPER PLATE / BALL BEARING REMOVAL

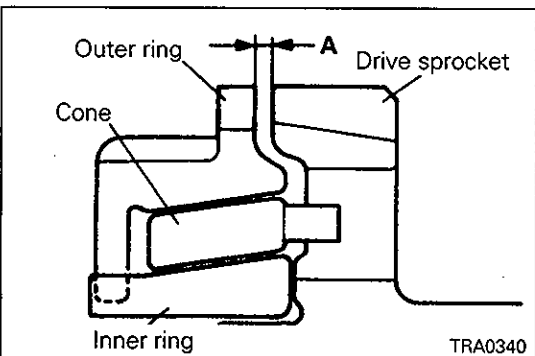

INSPECTION

OUTER SYNCHRONIZER RING / INNER SYNCHRONIZER RING / SYNCHRONIZER CONE

- (1) Combine the inner and outer synchronizer rings and cone with drive sprocket, and measure dimension A in the illustration. If dimension A is less than the limit, replace them as a set.

Limit value: 0.3 mm (0.012 in.)

REASSEMBLY SERVICE POINTS

▶A▶ BALL BEARING INSTALLATION

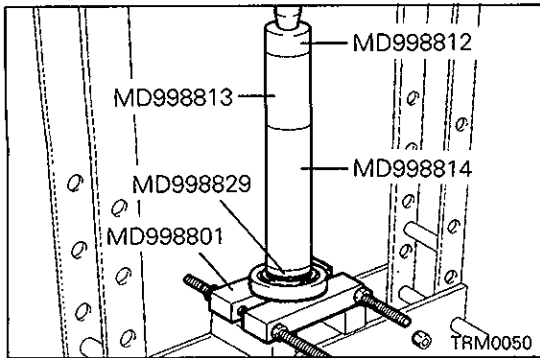

▶B▶ 2-4WD CLUTCH HUB INSTALLATION

(1) Direct the clutch hub as shown and install it to the rear output shaft.

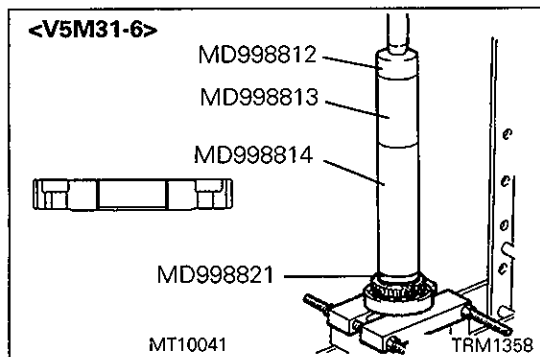
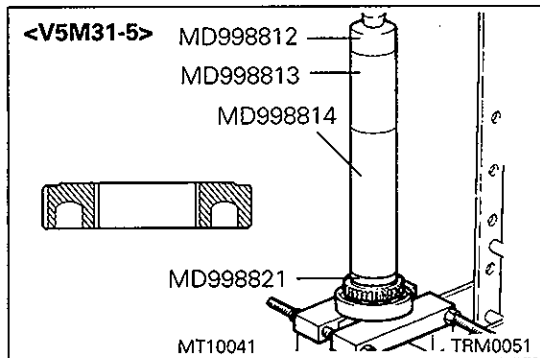

▶C▶ BALL BEARING INSTALLATION

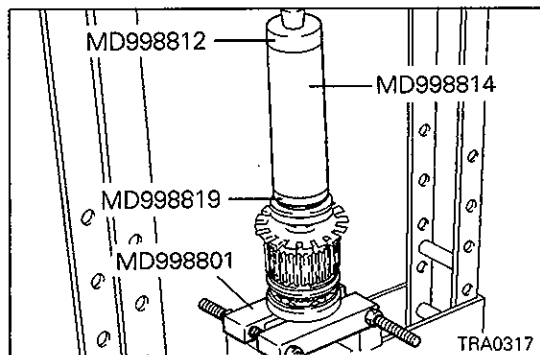

▶D▶ LOCK NUT INSTALLATION

(1) Use the special tool to tighten the lock nut to the specified torque.
 (2) Use a punch and hammer to stake the lock nut.

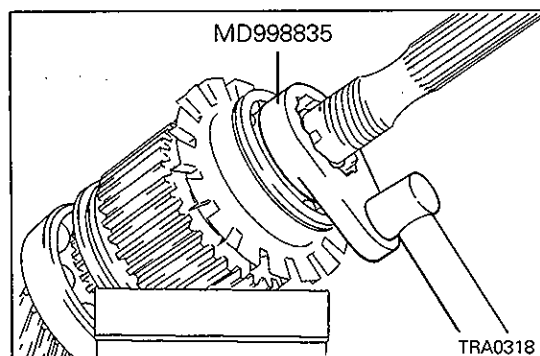

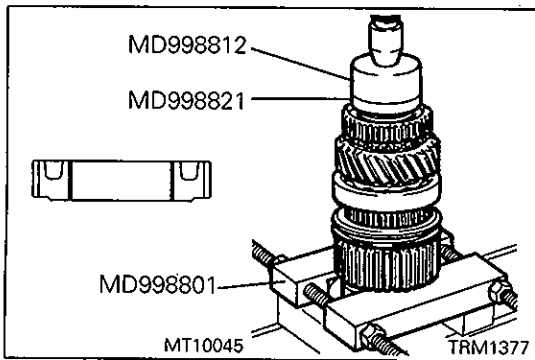

◆E◆ H-L CLUTCH HUB INSTALLATION

- (1) Direct the clutch hub as shown and install it to the rear output shaft.

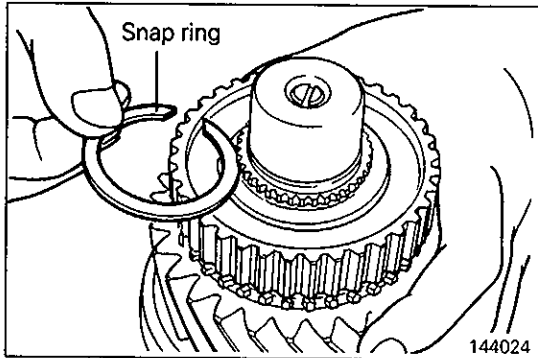

◆F◆ SNAP RING INSTALLATION

- (1) Select a snap ring that will adjust the end play of H-L clutch hub to the standard value:

Standard value: 0 – 0.08 mm (0 – 0.0031 in.)

NOTES

16. TRANSFER DRIVE SHAFT <V5M31 – SUPER SELECT 4WD> DISASSEMBLY AND REASSEMBLY

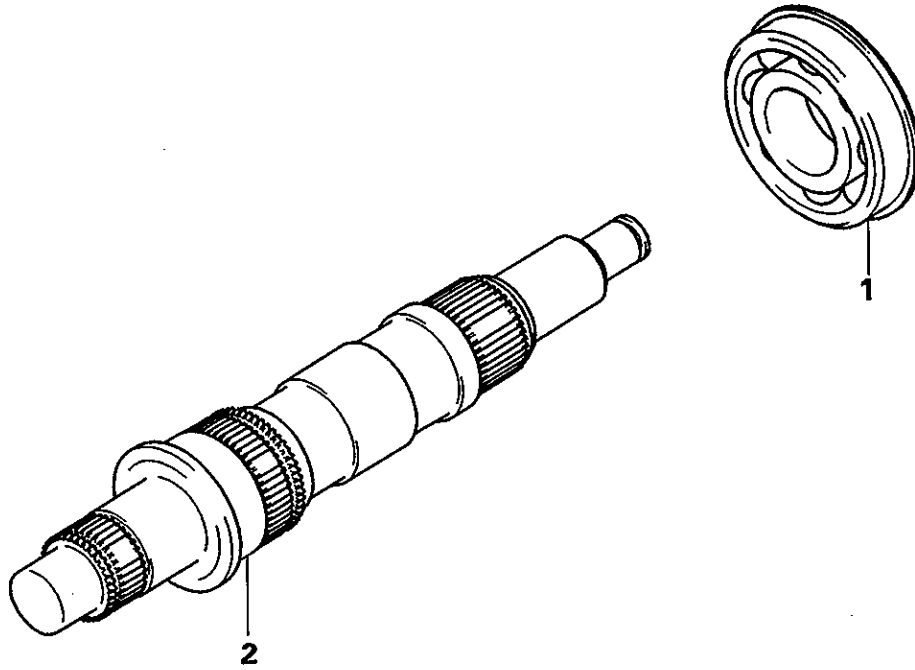

Disassembly steps

- ◊A◊▶A◊ 1. Ball bearing
- 2. Transfer drive shaft

TRM0510

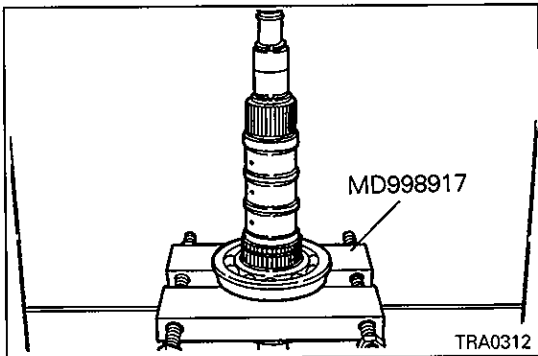

DISASSEMBLY SERVICE POINT

◊A◊ BALL BEARING REMOVAL

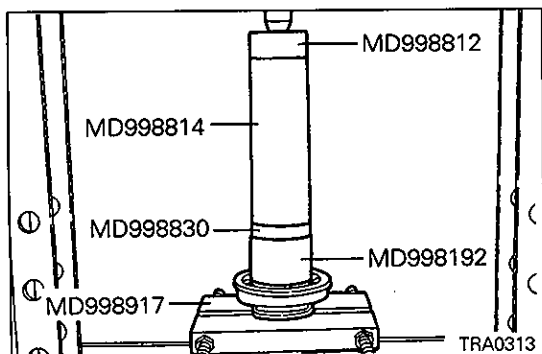

REASSEMBLY SERVICE POINT

▶A◊ BALL BEARING INSTALLATION

16a. TRANSFER DRIVE SHAFT <V5M31 – SUPER SELECT 4WD II>



Apply gear oil to all moving parts before installation.

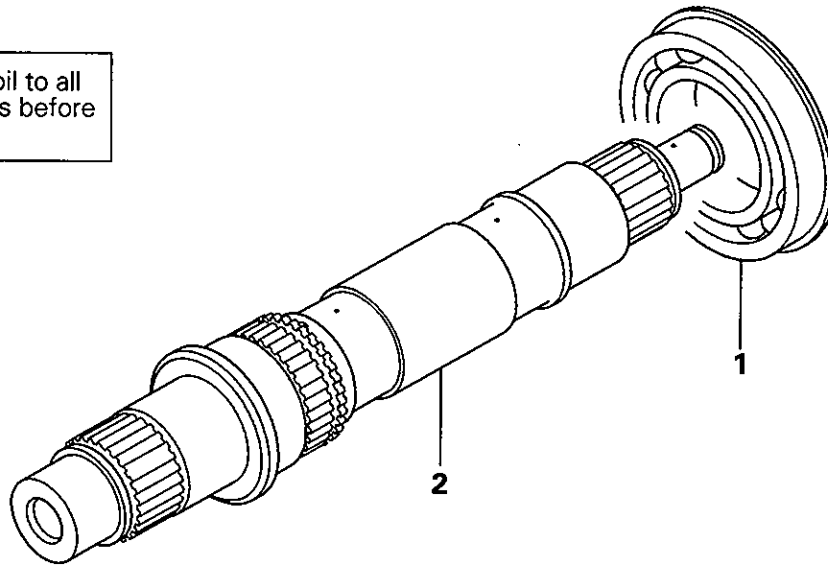

Disassembly steps

- ◊A◊ ▶▶ 1. Ball bearing
- 2. Transfer drive shaft

TRA1832

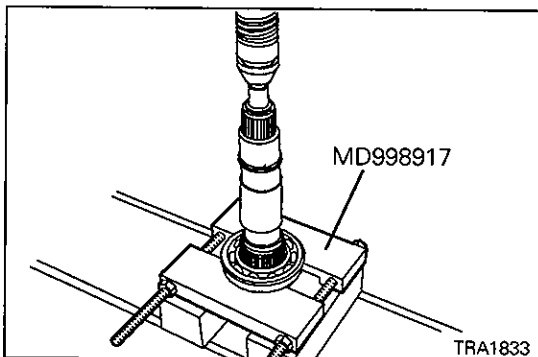

DISASSEMBLY SERVICE POINTS

◊A◊ **BALL BEARING REMOVAL**

- (1) Use the special tools to remove the ball bearing.

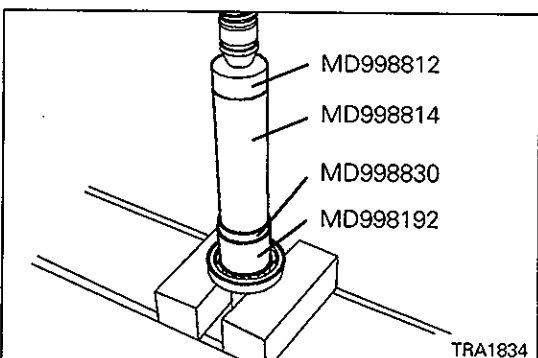

REASSEMBLY SERVICE POINTS

▶▶ **BALL BEARING INSTALLATION**

- (2) Use the special tools to install the ball bearing.

NOTES

17.FRONT OUTPUT SHAFT <V5M31 – PART TIME 4WD AND SUPER SELECT 4WD>

DISASSEMBLY AND REASSEMBLY

Apply gear oil to all moving parts before installation.

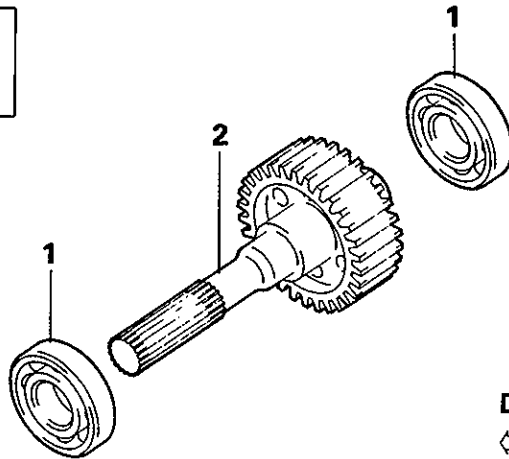

Disassembly steps
 ◁A▷▶A▶ 1. Ball bearing
 2. Front output shaft

TRA0319

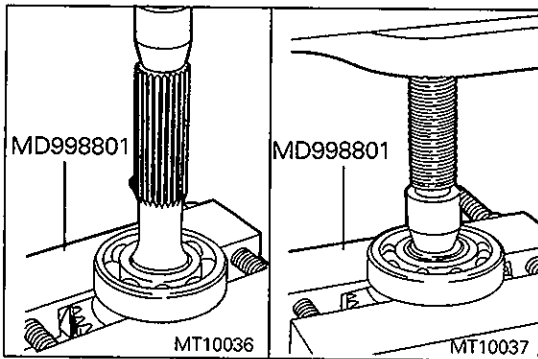

DISASSEMBLY SERVICE POINT

◁A▷ BALL BEARING REMOVAL

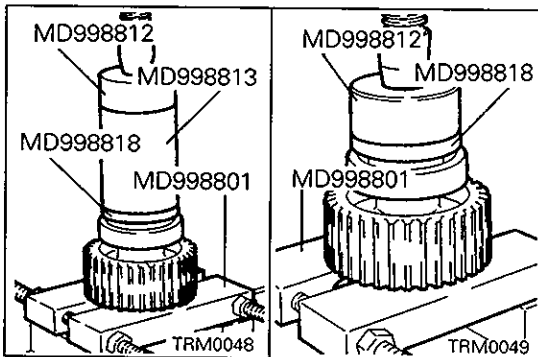

REASSEMBLY SERVICE POINT

▶A▶ BALL BEARING INSTALLATION

17a. FRONT OUTPUT SHAFT <V5M31 – SUPER SELECT 4WD II>



Apply gear oil to all moving parts before installation.

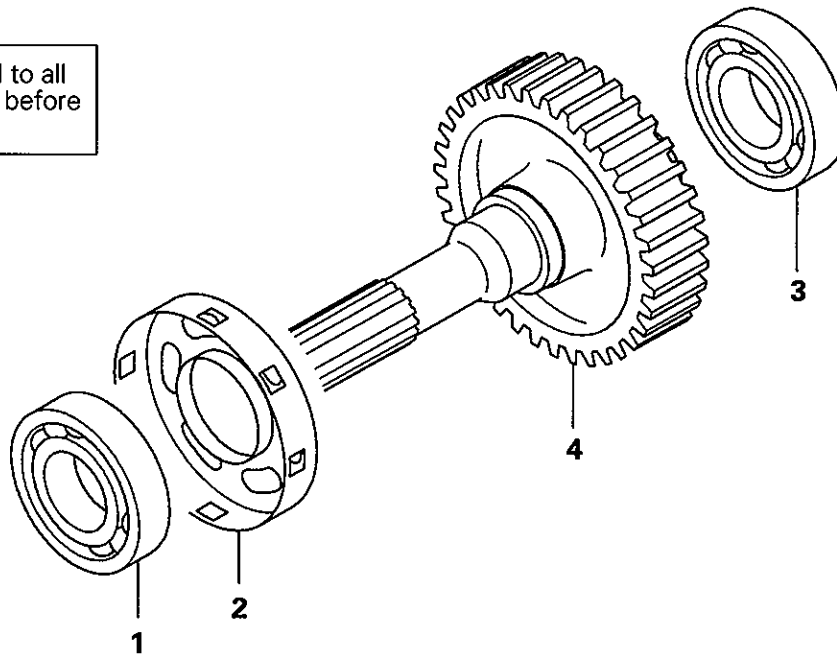

Disassembly steps

- ◁A▷ ▷B◁ 1. Ball bearing
- 2. Sensor rotor
- ◁B▷ ▷A◁ 3. Ball bearing
- 4. Front output shaft

TRA1817

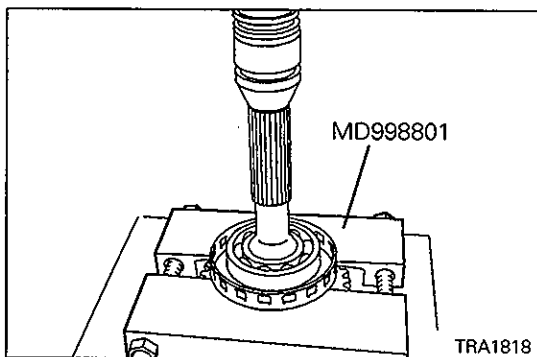

DISASSEMBLY SERVICE POINTS

◁A▷ **BALL BEARING REMOVAL**

(1) Use the special tools to remove the ball bearing.

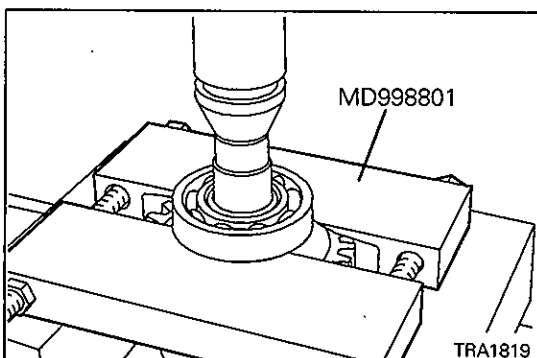

◁B▷ **BALL BEARING REMOVAL**

(1) Use the special tools to remove the ball bearing.

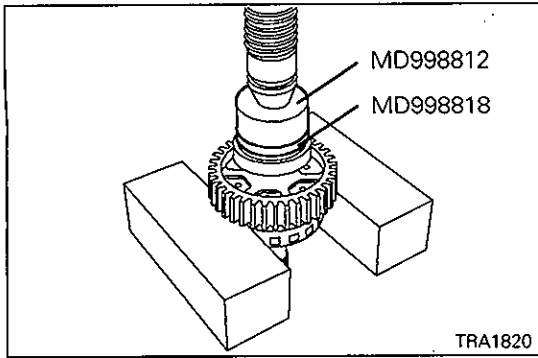

REASSEMBLY SERVICE POINTS

▶A◀ BALL BEARING INSTALLATION

(1) Use the special tools to install the ball bearing.

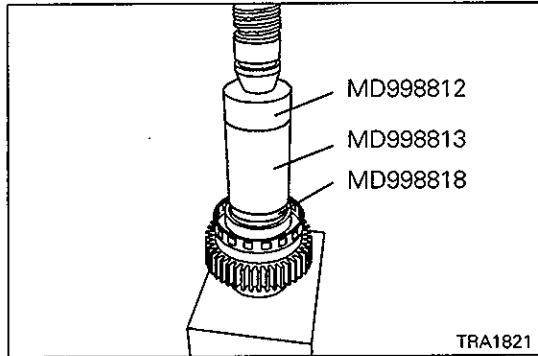

▶B◀ BALL BEARING INSTALLATION

(1) Use the special tools to install the ball bearing.

NOTES

18. SPEEDOMETER GEAR <R5M31, V5M31 – PART TIME 4WD AND SUPER SELECT 4WD> DISASSEMBLY AND REASSEMBLY



Apply gear oil to all moving parts before installation.

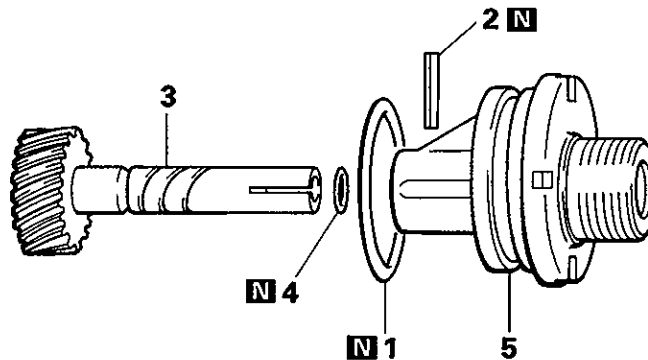

Disassembly steps

1. O-ring
- ▶▶▶ 2. Spring pin
3. Speedometer driven gear
4. O-ring
5. Sleeve

110008

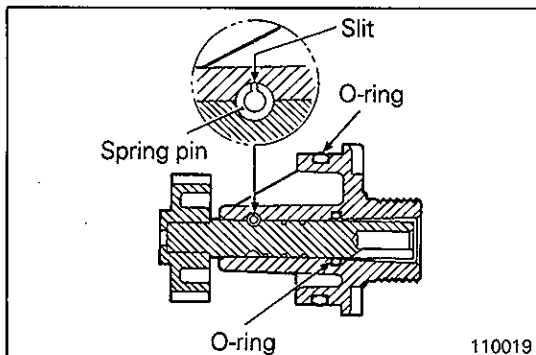

REASSEMBLY SERVICE POINT

▶▶▶ SPRING PIN INSTALLATION

- (1) Drive the spring pin into position so that its slit faces outward as illustrated.

NOTES

19. CONTROL HOUSING <R5M31>

DISASSEMBLY AND REASSEMBLY <Column shift type>

Apply gear oil to all moving parts before installation.

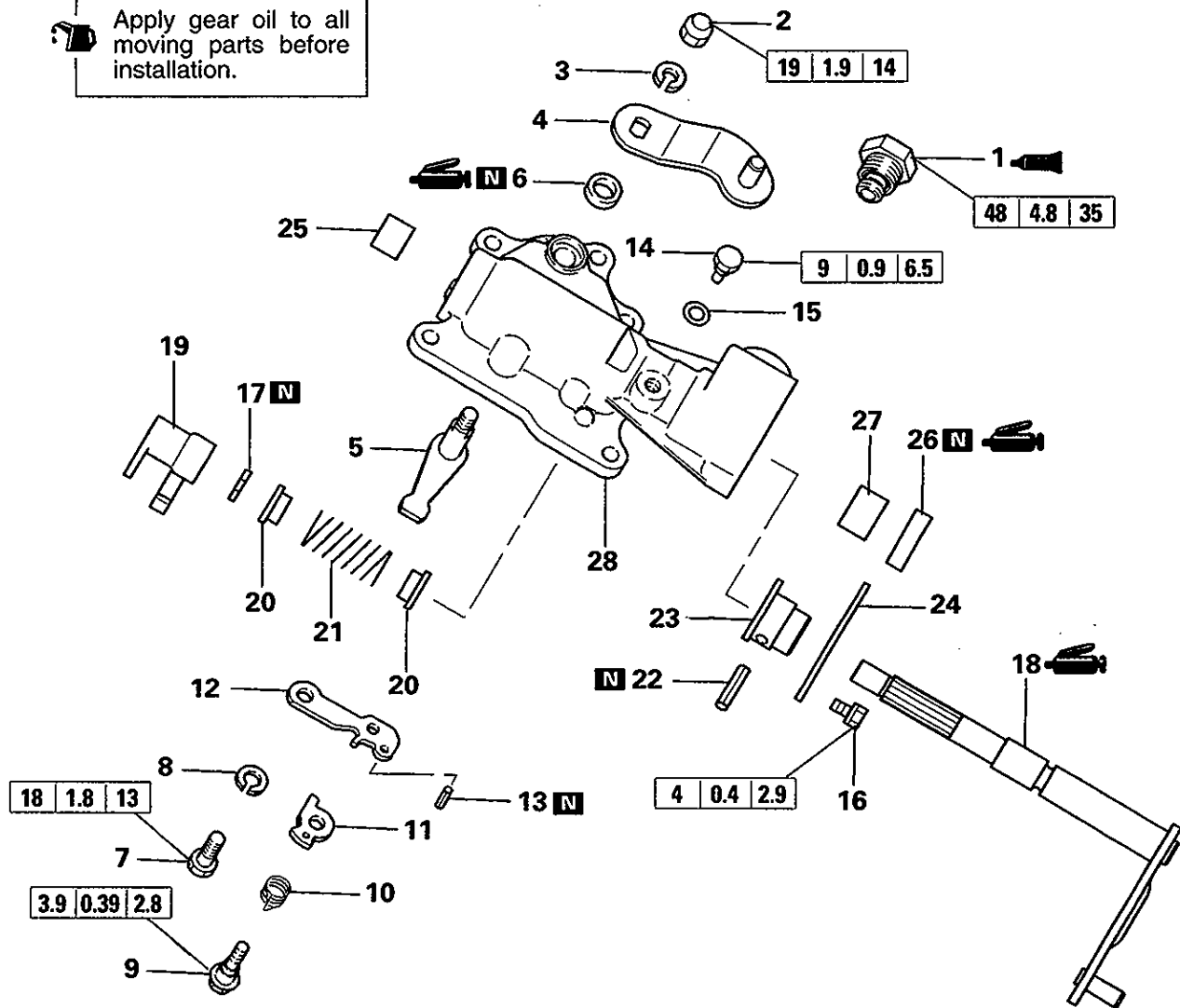

Disassembly steps

- | | | | |
|----|---------------------|----|--------------------------------|
| ▶L | 1. Plunger | ▶G | 15. Dish spring |
| | 2. Jam nut | | 16. Bolt |
| | 3. Spring washer | | 17. Snap ring |
| | 4. Select lever | ▶F | 18. Select lever |
| | 5. Select shaft | ▶F | 19. Control finger |
| ▶K | 6. Oil seal | | 20. Resistance spring retainer |
| | 7. Reamer bolt | | 21. Resistance spring |
| | 8. Spring washer | ▶E | 22. Spring pin |
| | 9. Flange bolt | ▶D | 23. Detent plate |
| ▶J | 10. Return spring | ▶C | 24. Cover |
| | 11. Stopper plate | ▶B | 25. Needle bearing |
| ▶I | 12. Stopper bracket | ▶A | 26. Oil seal |
| | 13. Spring pin | | 27. Needle bearing |
| ▶H | 14. Set screw | | 28. Control housing |

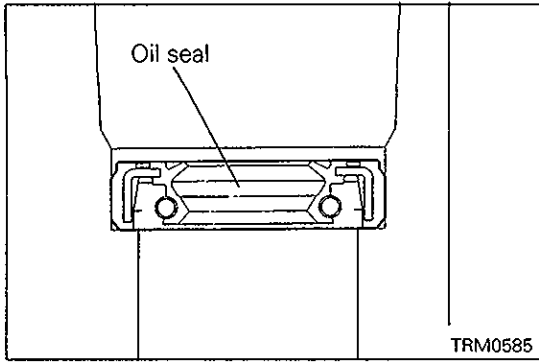

REASSEMBLY SERVICE POINTS

▶A◀ OIL SEAL INSTALLATION

- (1) After installation, pack grease between the lips of the oil seal.

Specified grease:

Mitsubishi genuine grease Part No. 0101011 or equivalent

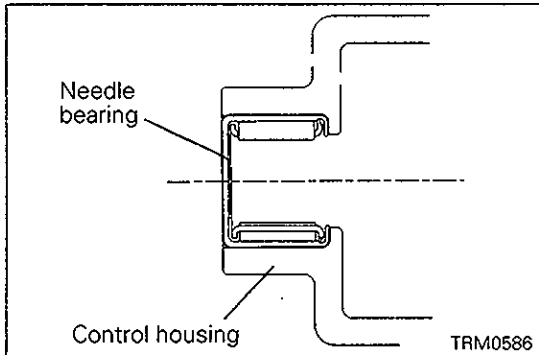

▶B◀ NEEDLE BEARING INSTALLATION

- (1) Install the needle bearing in the control housing as shown in the illustration.

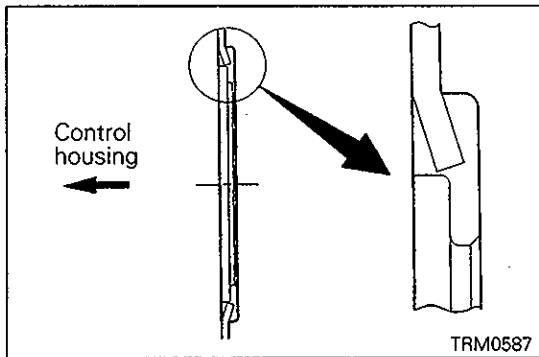

▶C◀ COVER INSTALLATION

- (1) Install the cover with its seal positioned as shown in the illustration.

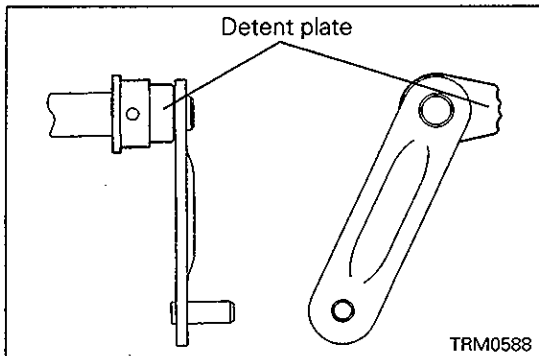

▶D◀ DETENT PLATE INSTALLATION

- (1) Install the detent plate as shown in the illustration.

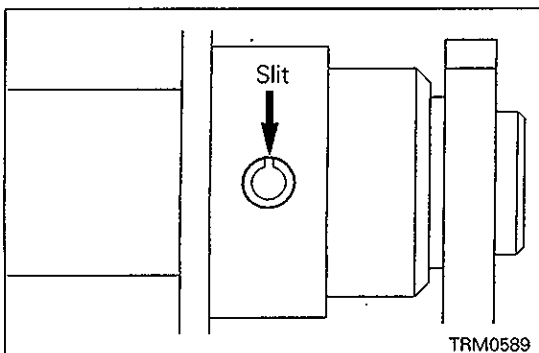

▶E◀ SPRING PIN INSTALLATION

- (1) Install the spring pin with its slit positioned as shown in the illustration.

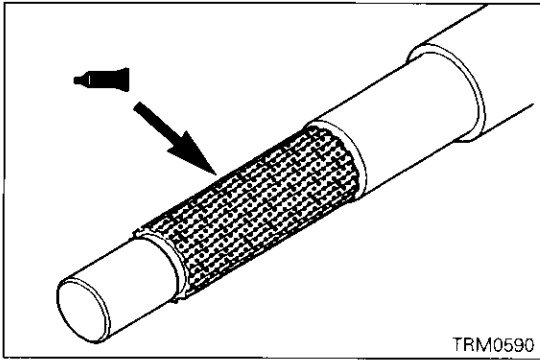

◆F◆ CONTROL FINGER / SELECT LEVER INSTALLATION

(1) Apply grease to the splines of the select lever.

Specified grease:

Mitsubishi genuine grease Part No. 0101011 or equivalent

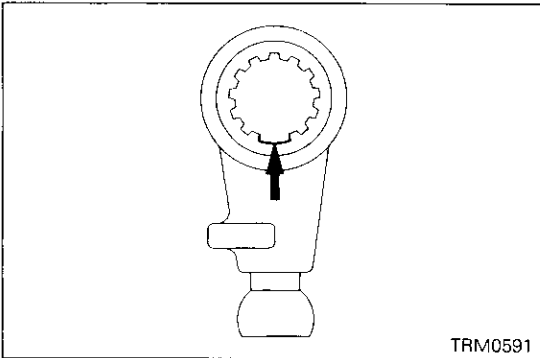

(2) Install the control finger to the select lever while aligning their wider key and keyway.

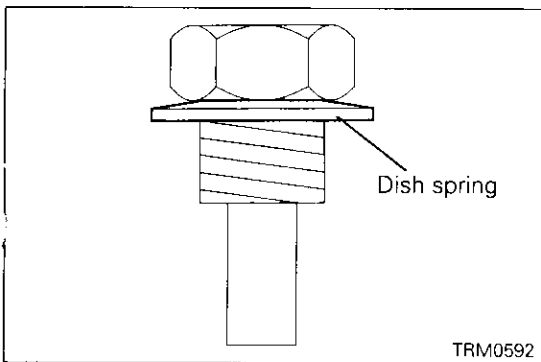

◆G◆ DISH SPRING INSTALLATION

(1) Install the dish spring as shown in the illustration.

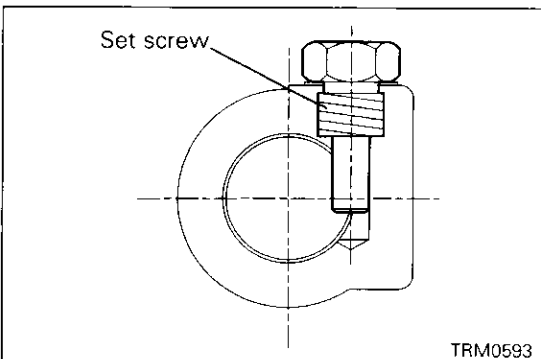

◆H◆ SET SCREW INSTALLATION

(1) Align the groove of the select lever with the set screw mounting hole and install the set screw.

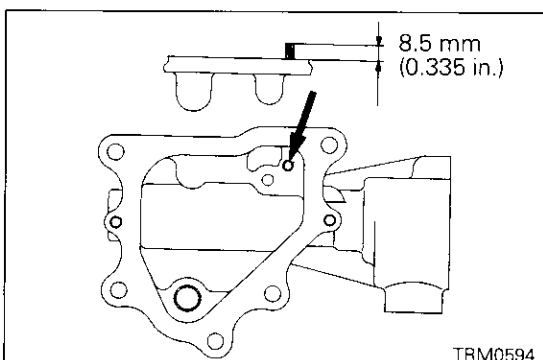

◆I◆ PRING PIN INSTALLATION

(1) Install the spring pin so that the dimension shown in the illustration is obtained.

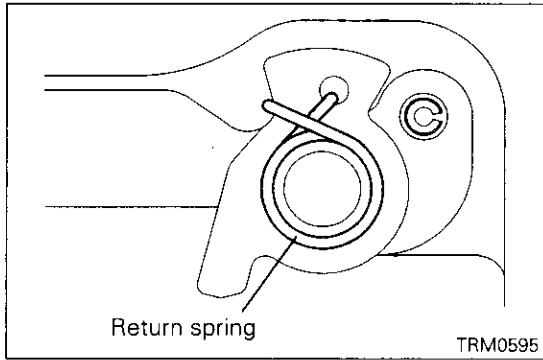

⇨J⇨ RETURN SPRING INSTALLATION

- (1) Install the return spring as shown in the illustration.

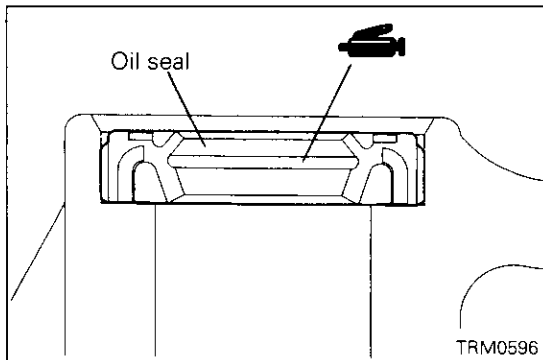

⇨K⇨ OIL SEAL INSTALLATION

- (1) After installation, pack grease between the lips of the oil seal.

Specified grease:

Mitsubishi genuine grease Part No. 0101011 or equivalent

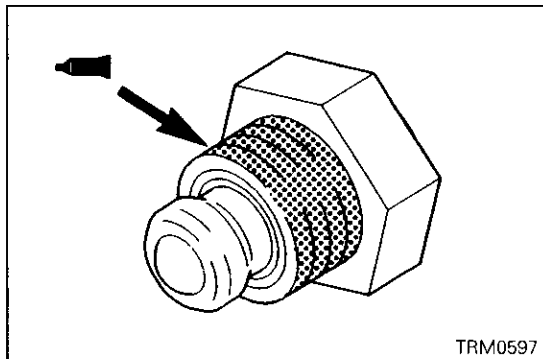

⇨L⇨ PLUNGER INSTALLATION

- (1) If a plunger is to be reused, apply sealant before installation.

Specified sealant:

3M ATD Part No. 8660 or equivalent

20. SHIFT RAIL DRIVE GEAR <V5M31 – SUPER SELECT 4WD II>



Apply gear oil to all moving parts before installation.

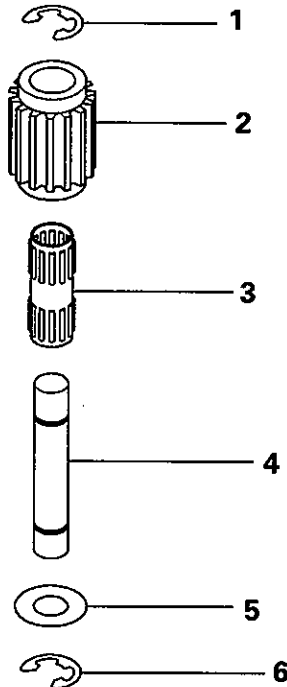

Disassembly steps

1. Snap ring
- ▶▶ 2. Shift rail drive gear
3. Bearing
4. Shift rail drive gear shaft
5. Washer
6. Snap ring

TRA1810

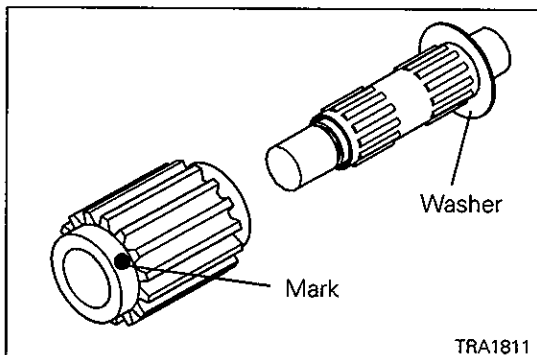

TRA1811

REASSEMBLY SERVICE POINTS

▶▶ SHIFT RAIL DRIVE GEAR INSTALLATION

- (1) Install the shift rail drive gear such that its mark does not face the washer.