

NEED HELP WITH INSTALLATION,
MAINTENANCE OR SERVICE?

Nintendo Customer Service
SUPPORT.NINTENDO.COM
or call 1-800-255-3700

BESOIN D'AIDE POUR L'INSTALLATIO
L'ENTRETIEN OU LA RÉPARATION?

Service à la Clientèle de Nintendo
SUPPORT.NINTENDO.COM
ou appelez le 1-800-255-3700

¿NECESITAS AYUDA DE INSTALACIÓN,
MANTENIMIENTO O SERVICIO?

Servicio al cliente de Nintendo
SUPPORT.NINTENDO.COM
o llama al 1-800-255-3700

NINTENDO  **DS**[™]  **XL**



Operations Manual



NINTENDO OF AMERICA INC.
P.O. BOX 957, REDMOND, WA 98073-0957 U.S.A.

70108A

PRINTED IN CHINA | MN-UTL-USZ

Français p.112 | Español p.224

Basics

Health and Safety Information	5
Nintendo DSi XL Components	7
Charging the Battery	11
Using the Stylus and Touch Screen	13
Adjusting the Volume and Screen Brightness	15
Using SD Memory Cards	16
Replacing the Battery Pack	17

Applications and Settings

Nintendo DSi Menu	21
Camera Mode	23
Using Game Cards	25
Nintendo DSi Camera	26
Using the Camera	27
Viewing the Album	37
Other Camera Features	39
Calendar	43
Nintendo DSi Sound	44
Recording and Playing with Sounds	45
Playing with Music on an SD Card	50
Settings	53
Nintendo DSi Shop	54
Using Nintendo DSi Shop	54
How to Redeem Nintendo DSi Points	55
DS Download Play	57
PictoChat	58
Nintendo DSi Browser	61
Flipnote Studio	62
System Settings	63
Data Management	65
Wireless Communication Settings	66
Brightness Settings	66
Profile	67
Date/Time/Alarm	68
Parental Controls	69
Touch Screen	72
Mic Test	72
Internet Setup	73
System Update	87
Format System Memory	87
Using the Keyboard	88

Support and Troubleshooting

Troubleshooting	91
Error Message List	99
Error Code List	100
Nintendo DSi Privacy Policy	103
Nintendo DSi Code of Conduct	106
Warranty and Service Information	107
Legal Notices	108
Glossary	109



Basics



Health and Safety Information

Important Safety Information – Read the following warnings before setup or use of the **Nintendo DSi XL system**. If this product will be used by young children, this manual should be read and explained to them by an adult. Failing to do so may cause injury. Please carefully review the instruction booklet for the game you are playing for additional health and safety information.

Throughout this manual, you will see this symbol  followed by WARNING or CAUTION, or you may see the term IMPORTANT. These terms have different levels of meaning as outlined below. Please read and understand these terms and the information that appears after them before using your **Nintendo DSi XL system**:

WARNING

Warns you about incorrect use of the **Nintendo DSi XL** that could result in serious personal injury.

CAUTION

Cautions you about incorrect use of the **Nintendo DSi XL** that could result in personal injury or damage to the **Nintendo DSi XL system**, components, games, or accessories.

IMPORTANT:

Informs you about incorrect use of the **Nintendo DSi XL** that could result in damage to the **Nintendo DSi XL system**, components, games, or accessories.

WARNING - Seizures

- Some people (about 1 in 4000) may have seizures or blackouts triggered by light flashes or patterns, and this may occur while they are watching TV or playing video games, even if they have never had a seizure before.
- Anyone who has had a seizure, loss of awareness, or other symptom linked to an epileptic condition should consult a doctor before playing a video game.
- Parents should watch their children play video games. Stop playing and consult a doctor if you or your child has any of the following symptoms:

Convulsions
Altered vision

Eye or muscle twitching
Involuntary movements

Loss of awareness
Disorientation

- To reduce the likelihood of a seizure when playing video games:
 1. Sit or stand as far from the screen as possible.
 2. Play video games on the smallest available television screen.
 3. Do not play if you are tired or need sleep.
 4. Play in a well-lit room.
 5. Take a 10 to 15 minute break every hour.

WARNING - Repetitive Motion Injuries and Eyestrain

Playing video games can make your muscles, joints, skin or eyes hurt. Follow these instructions to avoid problems such as tendinitis, carpal tunnel syndrome, skin irritation or eyestrain:

- Avoid excessive play. Parents should monitor their children for appropriate play.
- Take a 10 to 15 minute break every hour, even if you don't think you need it.
- When using the stylus, you do not need to grip it tightly or press it hard against the screen. Doing so may cause fatigue or discomfort.
- If your hands, wrists, arms or eyes become tired or sore while playing, or if you feel symptoms such as tingling, numbness, burning or stiffness, stop and rest for several hours before playing again.
- If you continue to have any of the above symptoms or other discomfort during or after play, stop playing and see a doctor.

WARNING - Battery Leakage

The Nintendo DSi contains a rechargeable lithium ion battery pack. Leakage of ingredients contained within the battery pack, or the combustion products of the ingredients, can cause personal injury as well as damage to your Nintendo DSi. If battery leakage occurs, avoid contact with skin. If contact occurs, immediately wash thoroughly with soap and water. If liquid leaking from a battery pack comes into contact with your eyes, immediately flush thoroughly with water and see a doctor.

To avoid battery leakage:

- Do not expose battery to excessive physical shock, vibration, or liquids.
- Do not disassemble, attempt to repair or deform the battery.
- Do not dispose of battery pack in a fire.
- Do not touch the terminals of the battery, or cause a short between the terminals with a metal object.
- Do not peel or damage the battery label.

WARNING - Radio Frequency Interference

The Nintendo DSi can emit radio waves that can affect the operation of nearby electronics, including cardiac pacemakers.

- Do not operate the Nintendo DSi within 9 inches of a pacemaker while using the wireless feature.
- If you have a pacemaker or other implanted medical device, do not use the wireless feature of a Nintendo DSi without first consulting your doctor or the manufacturer of your medical device.
- Observe and follow all regulations and rules regarding use of wireless devices in locations such as hospitals, airports, and on board aircraft. Operation in those locations may interfere with or cause malfunctions of equipment, with resulting injuries to persons or damage to property.

IMPORTANT: The Nintendo DSi XL allows you to disable wireless communications. Select SYSTEM SETTINGS from the Nintendo DSi Menu, then select WIRELESS COMMUNICATIONS and OFF to disable this feature.

Refer to the separate Nintendo DS Health and Safety Precautions booklet for additional information on hardware and software precautions and maintenance.

NOTE: This product does not contain latex.

This product complies with applicable laws barring the use of toxic materials such as lead, mercury, cadmium, hexavalent chromium, PBB or PBDE in consumer products.



View of the Nintendo DSi XL system when open (front)

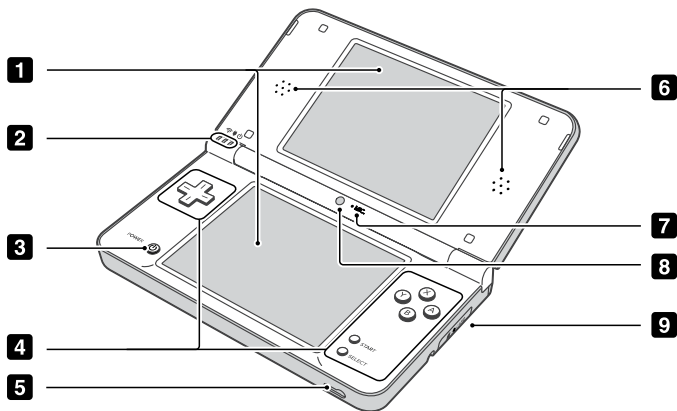

1 Upper and Lower LCD Screens

Twin backlit color liquid crystal screens display game screens and other information. The brightness of the screens can be adjusted in 5 levels. SEE PAGE 15

The lower display (the Touch Screen) is touch sensitive and should be operated only with a Nintendo licensed stylus.



When opening the Nintendo DSi XL, keep your fingers away from the hinge to avoid pinching them.

2 Indicator LEDs

SEE PAGE 8

3 Power/Reset Button

Press this button to turn the system on. When the system is on, pressing this button briefly will reset the system and return to the menu screen. Pressing and momentarily holding this button will turn the system off.

4 Control Buttons (The +Control Pad, A, B, X, and Y Buttons, and START and SELECT)

For game play control. See the instruction booklet for the game you are playing for specific control information.

5 Headphone/Microphone Connectors

For connection of stereo headphones, external microphone, or headset (all sold separately). If an accessory is connected, no sound will play through the speakers.



When using earphones, set the volume at a safe level. Setting the volume too high may harm your hearing or damage the earphones.

6 Stereo Speakers

7 Microphone

Used by games or other applications that include the microphone feature.

8 Inner Camera

Used by games or other applications that use the camera feature. SEE PAGE 26

NOTE: Avoid getting the camera lens dirty. If it becomes dirty, wipe gently with a soft cloth, being careful not to damage the lens.

9 SD Card Slot

For inserting SD Memory Cards (sold separately). SEE PAGE 16

Indicator LEDs



Wireless Indicator LED

Lights yellow when wireless communications features are enabled for use.

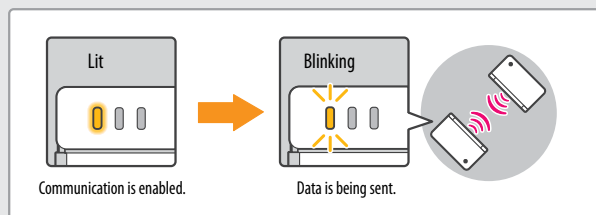

Recharge Indicator LED

Lights orange when the battery is being charged.

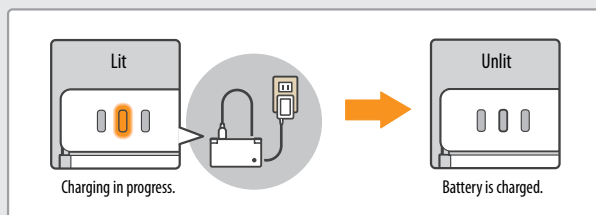

NOTE: If you play a game while the battery is recharging, the recharge indicator LED may not always turn off when the charging is complete. This is normal.

IMPORTANT: If the recharge indicator LED is blinking, the battery pack may not be installed properly. Check the battery placement to be sure it is installed correctly.



Power Indicator LED

Indicates the battery charge level when the power is on (see diagram below).

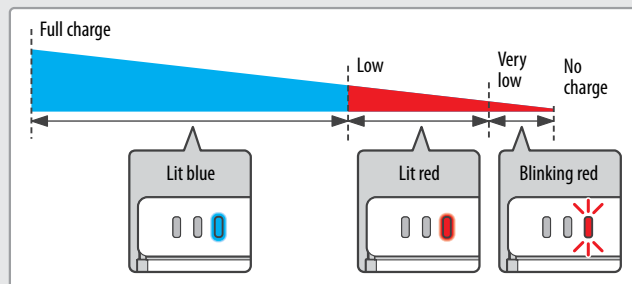

NOTE: When the power indicator LED turns red, be sure to save your game and recharge the battery.

If the LED begins to blink during game play, your power is getting very low. If the battery runs out of power before you save your game, any unsaved data will be lost.

NOTE: A blinking power indicator LED, when the system is closed, indicates that the system is in Sleep Mode and is conserving power.

Nintendo DSi XL (back view)

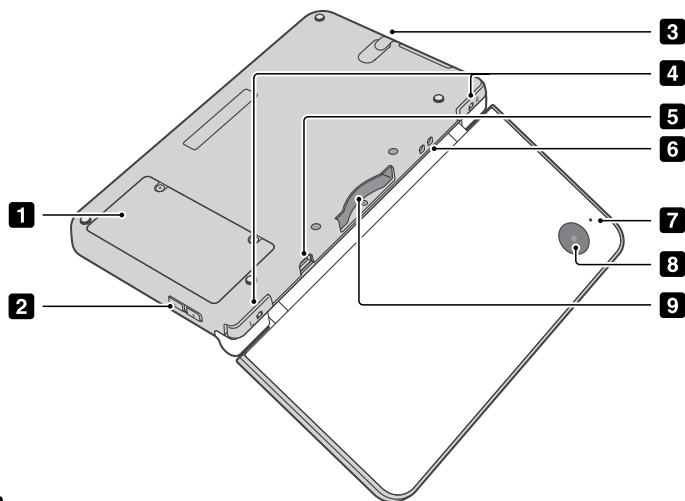

1 Battery Cover

Remove cover to replace the battery. **NOTE:** Do not remove the cover unless you need to replace the battery or check battery installation.

SEE PAGE 17

2 Volume / Screen Brightness Control

Adjust the sound volume or the brightness of the screens.

SEE PAGE 15

3 Stylus Holder

Always replace the stylus into the stylus holder after use. **NOTE:** To prevent damage to the **Nintendo DSi XL**, do not insert anything other than a **Nintendo DSi XL** licensed stylus into the stylus holder.

4 Control Buttons [L and R Buttons]

For game play control. See the instructions for the game you are playing for specific control information.

5 AC Adapter Connector

Allows connection of Nintendo DSi AC Adapter (included), for recharging the battery or operation using household current.

SEE PAGE 11

6 Wrist Strap Attachment

For attachment of a wrist strap (sold separately).

7 Camera Indicator LED

Lights when the outer camera is in use.

8 Outer Camera

Used by games or other applications that use the camera feature.

NOTE: Avoid getting the camera lens dirty. If it becomes dirty, wipe gently with a soft cloth, being careful not to damage the lens.

9 DS Game Card Slot

For loading Nintendo DSi and Nintendo DS Game Cards (sold separately).

Nintendo DSi AC Adapter Model No. WAP-002(USA)

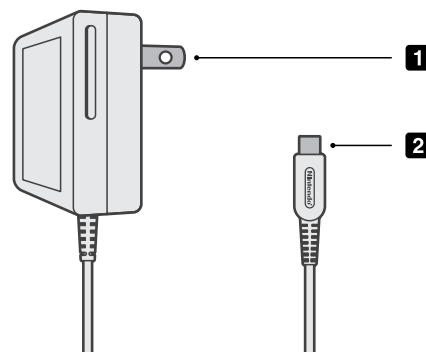

1 AC Adapter Plug

Plugs into a standard 120-volt AC wall outlet.

2 DC Connector Plug

Plugs into the AC adapter connector on the back of the **Nintendo DSi XL**.

Nintendo DSi XL Stylus

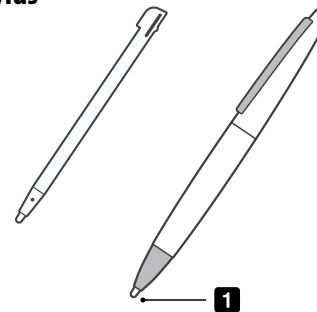

1 Stylus Tip

For use on the lower screen (Touch Screen) of the **Nintendo DSi XL**.

The system comes with two styluses. One is shipped in the stylus holder on the side of the system and the other is contained within the box. Make sure to keep the other stylus as a backup.

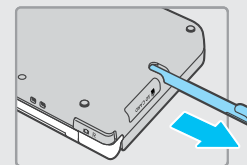

Charging the Battery

WARNING Do not use the Nintendo DSi AC Adapter during a lightning storm. There may be a risk of electric shock from lightning.





- Be sure to charge the battery before using it for the first time or when it has not been used in the last 6 months.

Battery recharge time is approximately **3 hours**, although this will vary depending on the remaining charge when you begin to recharge the battery. You can play games while the battery is charging, but this will increase the recharge time.

When fully charged, the battery will last from **13-17 hours on the lowest screen brightness setting**, depending on the type of game activity. See page 15 for information on adjusting the screen brightness. On the brightest setting, the battery life is **4-5 hours**. See the table below.

Using the wireless communications or camera features may reduce the battery time to less than the figures shown to the right.

NOTE: The default system setting is configured to the “High” setting.

	Highest	Approx. 4-5 hours
	High	Approx. 6-8 hours
	Medium	Approx. 9-11 hours
	Low	Approx. 11-14 hours
	Lowest	Approx. 13-17 hours

The battery can be recharged approximately 500 times, but performance may decrease after repeated recharges, depending on usage conditions such as temperature. Optimal charging temperature is between 41° and 95° Fahrenheit (5-35° Celsius). Battery life may also decrease over time. After 500 recharges, battery life may be only 70% of the battery life when new.

Charging the battery

IMPORTANT: The Nintendo DSi AC Adapter, Model No. WAP-002(USA), is for use only with the Nintendo DSi and Nintendo DSi XL portable video game systems. It is not compatible with any other Nintendo system. Do not use the AC Adapter with voltage transformers, dimmer switches, or any other equipment. It is only for use in a standard 120-volt AC wall outlet.

- Insert the DC plug from the AC Adapter into the system's AC Adapter connector on the back of the Nintendo DSi XL. Be sure to insert it straight into the connector.

IMPORTANT: Be sure the DC Connector Plug is facing in the correct direction before inserting into the connector to avoid damaging either the plug or connector.

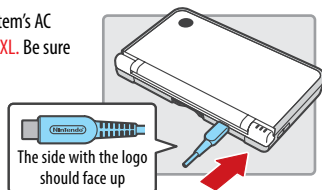

- Swing the prongs out of the AC Adapter and insert into a standard 120-volt AC wall outlet.

The AC Adapter should be correctly oriented in a vertical or floor mounted-position. The cord should always face downward.

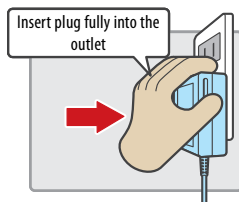

- When fully charged, the recharge indicator LED will go out.

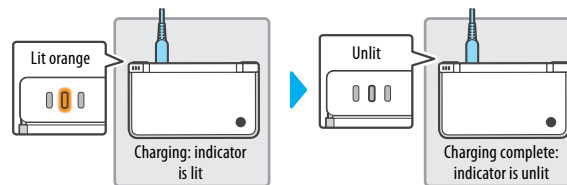

- If the recharge indicator LED is not lit, make sure the AC Adapter is connected properly to both the system and the outlet.
- If the recharge indicator LED is blinking, there is a chance that the battery pack is not installed correctly. Check to make sure installation is correct (see page 17).

NOTE: If you play a game while the system is recharging, the recharge indicator LED may not always turn off once charging has completed. This is not a malfunction.

- Remove the AC Adapter from the wall outlet and fold the prongs back into the housing. Remove the DC plug from the AC Adapter connector.

IMPORTANT: When disconnecting any plugs from the Nintendo DSi XL or wall outlet, carefully pull by the plug itself rather than by the cord.

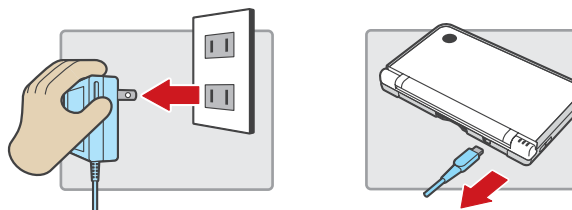

IMPORTANT BATTERY GUIDELINES:

- Do not remove the battery from the Nintendo DSi XL unless it needs to be replaced.
- Do not use any battery other than the Nintendo DSi XL rechargeable battery, Model No. UTL-003. A replacement battery may be ordered through Nintendo's website at store.nintendo.com (USA/Canada only) or by calling Customer Service at 1-800-255-3700.
- When recharging the battery, use ONLY the included AC Adapter, Model No. WAP-002(USA).
- When disposing of the battery, follow appropriate local guidelines and regulations. For information on battery disposal contact your local solid waste authority. See page 17 for more information on battery disposal.
- If liquid comes into contact with the battery, do not reuse it. Call Nintendo Customer Service at 1-800-255-3700 for further instructions on battery replacement and possible service to your Nintendo DSi XL.

Using the Stylus and Touch Screen

Using the Nintendo DSi XL Stylus

The lower LCD screen, or Touch Screen, is touch sensitive. For games that include this game control feature, operate the screen by using the included stylus. Lightly touch or slide the stylus across the Touch Screen as shown below.

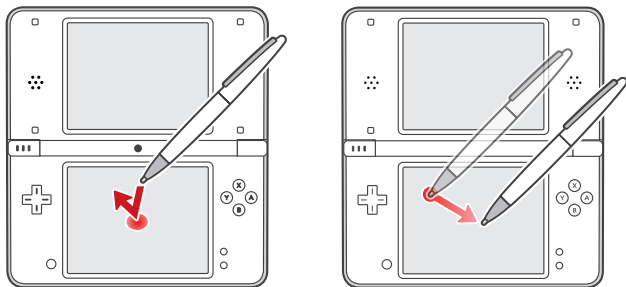

IMPORTANT STYLUS AND SCREEN GUIDELINES:

- Use the stylus **ONLY** on the Touch Screen (lower screen).
- Use only enough pressure to operate the game. Excessive pressure may damage the Touch Screen.
- Do not use the stylus if it is broken.
- Use only a Nintendo licensed stylus on the Touch Screen.
- Replace the stylus in the stylus holder when not in use.
- If you use a screen protector on your **Nintendo DS XL**, use only a Nintendo licensed screen protector, and use it only on the Touch Screen.

IMPORTANT: If the Touch Screen becomes dirty or contaminated with foreign material, do not continue to use your **Nintendo DSi XL**. It may not work properly and can become more damaged. Follow the cleaning procedures below. If it still does not work after cleaning, visit www.nintendo.com for information on repair service.

Screen Cleaning Procedure

If the screens on your **Nintendo DSi XL** have visible smudges, fingerprints, or other foreign material on them, you can clean them by using a soft clean cloth such as a lens or eyeglass cleaning cloth.

1. Slightly dampen the cloth with water **ONLY** and wipe off the screens to loosen any dirt or foreign material.
2. Using a dry cloth, wipe the screens to dry them and finish the cleaning process. If needed, repeat the process.

Calibrating the Touch Screen

You can adjust the Touch Screen if it doesn't seem to respond properly or if the Touch Screen is not responding to the same place you're touching it.

NOTE: If you have applied a commercially available screen protector to your Touch Screen, be sure it has been applied correctly before attempting to calibrate the Touch Screen.

1. Select **System Settings** from the Nintendo DSi Menu.
2. Select screen number 3 by tapping the #3 box at the top of the screen or by tapping the arrow on the right side of the screen until you see the screen with the **Touch Screen** option.
3. Select the **Touch Screen** option and follow the on-screen instructions.

If you're still unable to operate the Touch Screen properly...

Try starting up your **Nintendo DSi XL** at the Touch Screen Calibration screen by following the procedure below.

1. While holding down the L Button, R Button and START...

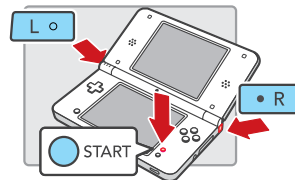

2. Press POWER. (Hold down the L, R, and START Buttons until the Calibration screen appears.)

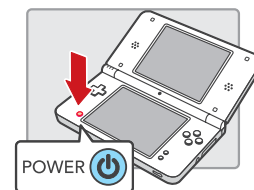

3. Follow the on-screen instructions and then turn the power off. Turn the system on again to check the operation of the Touch Screen.



Adjusting the Volume/Screen Brightness

Adjusting the volume

1. Press the Volume/Screen Brightness Control in either direction to change the volume.
- Press plus (+) to increase the volume or minus (-) to decrease the volume.
- When the system is in Sleep Mode, the volume can be decreased but not increased.

NOTE: The camera's shutter sound will always play at a fixed volume, regardless of the current setting of the volume control.

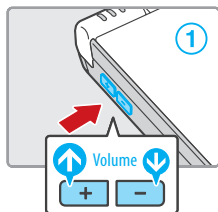

IMPORTANT: Under some conditions, noise from the **Nintendo DSi XL** speakers can cause audio feedback with the **Nintendo DSi XL** microphone. If you hear screeching, howling or other unexpected noise from the speakers, turn down the volume or use a set of stereo headphones.

How to start the system with low (muted) volume

Turn the power on while holding down the minus (-) side of the volume/brightness control.

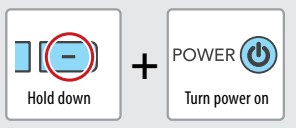

Adjusting the screen brightness

1. Hold down SELECT.
 2. Press the Volume/Screen Brightness Control in either direction to change the screen brightness.
- Press plus (+) to increase the brightness or minus (-) to decrease the brightness.

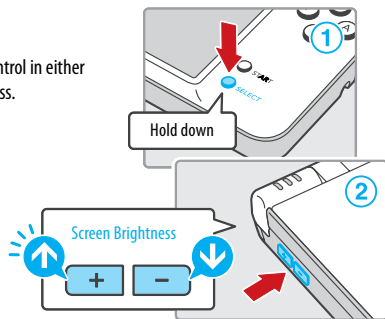

NOTE: Changing the screen brightness will also change the brightness of the power indicator LED and the wireless indicator LED.

NOTE: Increasing the screen brightness will increase the power consumption. As a result, the power indicator LED may change from blue to red when the screen is made brighter. When this happens, note that the battery may run out and the system may lose power soon after the LED turns red.

The relationship between screen brightness and battery duration

Increasing the screen brightness will reduce the battery life. Decreasing the screen brightness will increase the battery life. Adjust the brightness based on your preference. See page 11 for more information.



Using SD Memory Cards

The **Nintendo DSi XL** supports high-capacity SD Cards over 2 GB in size (SDHC Cards). With commercially available SD Cards you will be able to:

- Save photos you've taken in Nintendo DSi Camera to the SD Card
- Play AAC-format audio files saved on the SD Card
- Copy downloadable software and its save data to the SD Card

NOTE:

It may not be possible to copy some software.
Data copied to SD Cards cannot be used on other systems.
Save data on Game Cards cannot be copied.
Song or sound files from the SD Card that have been manipulated are not saved.

IMPORTANT: An SD Card adapter is required to use miniSD or microSD Cards. When using a card adapter, be sure to remove the entire adapter (not just the card). Malfunction or damage to the system or your data could result if the card adapter is left in the system.

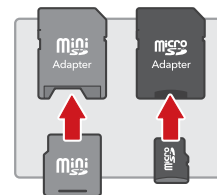

Inserting an SD Card

1. Open the SD Card slot cover.

Do not pull or twist the slot cover forcefully. Doing so could stretch or deform it, which could prevent the cover from closing correctly.

2. Insert the SD Card into the SD Card slot until it clicks into place. Make sure the label side faces down.

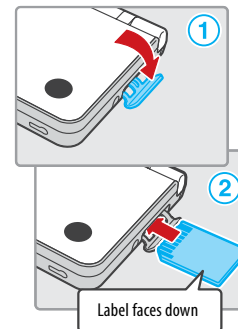

Removing an SD Card

1. Open the SD Card slot cover and press on the end of the card until it clicks and partially ejects from the slot.
2. Grasp the SD Card and remove from the card slot.

IMPORTANT: Do not remove the SD Card while data is being read or written. This could damage the system or the SD Card, or destroy data.

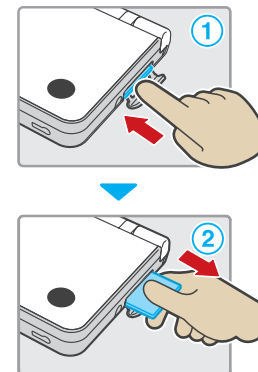



Replacing the Battery Pack

Battery packs become worn with repeated charge/discharge cycles, and the amount of time they can be used when fully charged will decrease gradually over time. If you feel the usage time has dropped off noticeably, replace the battery pack.

- **Do not use any battery other than the Nintendo DSi XL rechargeable battery, Model No UTL-003.** A replacement battery may be ordered through Nintendo's web site at store.nintendo.com (USA/Canada only) or by calling Customer Service at 1-800-255-3700.
- **A parent or guardian should replace the battery pack if a young child is using the system.**

PLEASE RECYCLE YOUR USED BATTERIES

When disposing of a rechargeable battery, please be sure to follow appropriate local guidelines and regulations.

- Do not disassemble, attempt to repair, or deform the battery pack.
- Do not dispose of rechargeable batteries in a fire.

To find a collection site near you, please contact your local solid waste authority or visit:

<http://www.epa.gov/osw/conservation/materials/battery.htm>

For more information or for assistance from Nintendo, e-mail us at nintendo@noa.nintendo.com.

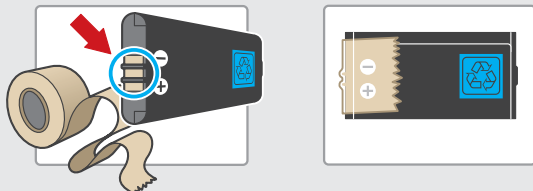

- Place tape over the battery contacts before recycling.

Before replacing the battery...

1. Press and hold the Power/Reset button (at least .5 second) until the power shuts off.
2. Make sure the AC Adapter is unplugged from the Nintendo DSi.

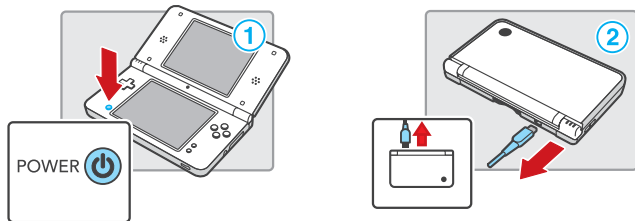

Battery replacement procedure

1. Loosen the two Phillips-head (+) screws on the battery cover with a screwdriver, and remove the battery cover.

IMPORTANT: To avoid damage to the screw or threads, use a screwdriver that is appropriate for the screw.

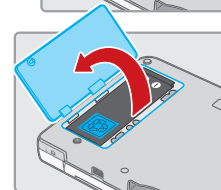
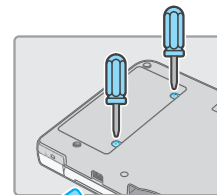

2. Remove the battery pack as shown at right.



3. Orient the new battery as shown and carefully insert completely into the battery compartment.

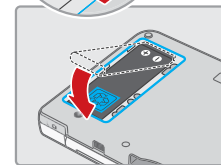
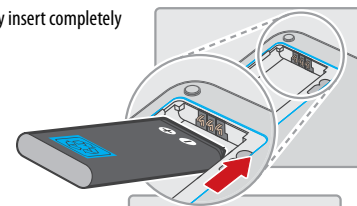

4. Replace the battery cover, and tighten the two screws, being careful not to overtighten.

IMPORTANT: Always be sure to replace the battery cover and tighten the screws before resuming use.

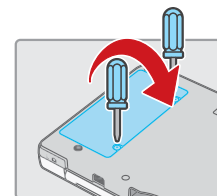



Applications and Settings



Nintendo DSi Menu

The Nintendo DSi Menu appears automatically when you turn the system's power on. On this menu you will see icons for the system's built-in applications and for any Nintendo DS or Nintendo DSi Game Card inserted into the DS Game Card slot. Tap these icons to play games, use the applications, or enter system settings. You can also press **L** or **R** to enter camera mode and take photos.

Screen Explanation

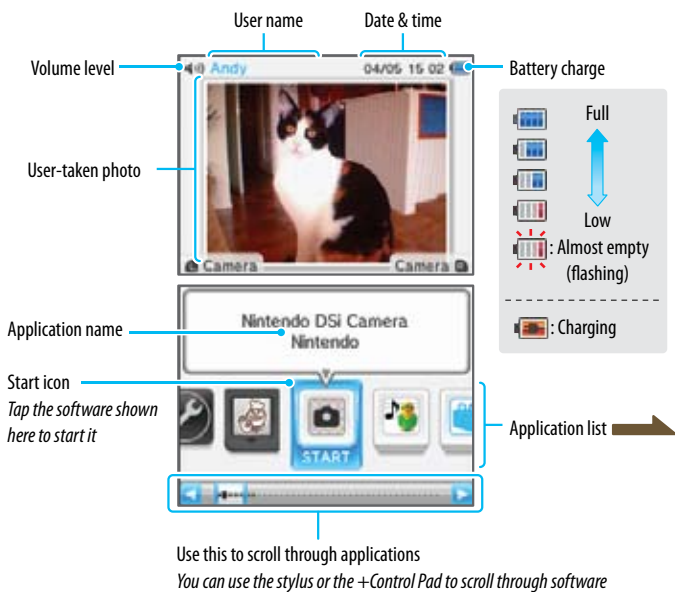

Use this to scroll through applications
You can use the stylus or the +Control Pad to scroll through software

Moving Icons



1 Use the stylus to select the icon you want to move and then slide it up to the center of the screen.

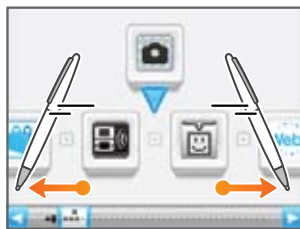

2 Scroll through the software list until you come to the spot you want to place the software icon.

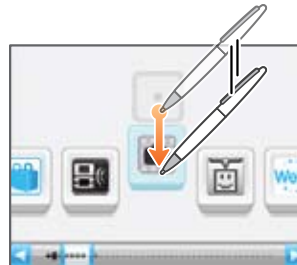

3 Tap the icon once again and slide it into its new location.



4 That's it! You're done.

Application Icons

Here are the icons you'll see on the software list.

Card Software Icons



This icon appears when there is no Game Card inserted in the DS Card Slot.



When a Game Card is inserted in the DS Card Slot, an icon for that game will appear. The Personal Trainer: Cooking icon is shown here.

Built-in Software Icons

These are the icons of the system's built-in software applications.



System Settings
See page 63



Nintendo DSi Camera
See page 26.



Nintendo DSi Sound
See page 44.



Nintendo DSi Shop
See page 54.



DS Download Play
See page 57.



PictoChat
See page 58.



Nintendo DSi Browser
See page 61.



Flipnote Studio
See page 62.

Other



Open Icon
This icon appears when no application is present. The number of empty boxes represents the number of applications that can be added.



Nintendo DSi + Internet Icon
Select this icon from the Nintendo DSi Menu to watch a video showing the many advantages of connecting your Nintendo DSi system to the Internet. You can delete this later to open up memory space.



Present Icon
This icon appears when you add a new application by downloading it via Nintendo DSi Shop, or through some other means. Tap a present icon to reveal the application icon.

Camera Mode

On the Nintendo DSi Menu, press **L**  or **R**  to enter camera mode.
Photos you take will be saved to the Nintendo DSi XL system memory.

SD Cards can save up to 3,000 photos max, regardless of how much space they have.

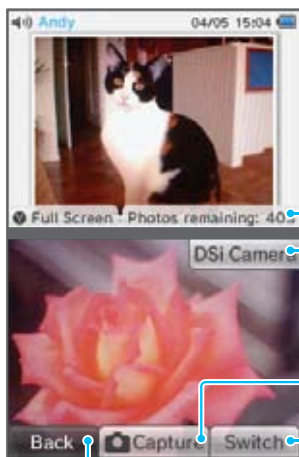

Number of photos remaining

Start Nintendo DSi Camera

Take a photo (**L** , **R** , or **A**)

Switch between inner and outer cameras. (**X**)

Return to the Nintendo DSi Menu. (**B**)

 Turn control displays on and off. (**Y**)

(You can also use the buttons shown in parentheses.)

Top-Screen Photo Display

- Photos taken in camera mode will appear on the top screen of the Nintendo DSi Menu.

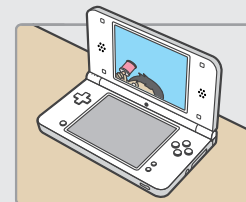

- If you have taken multiple photos in camera mode, the photo that appears on the top screen will change every time you turn the Nintendo DSi XL on or exit Sleep Mode by opening the Nintendo DSi XL.

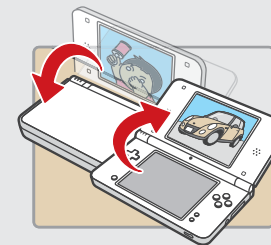

- You can use the Nintendo DSi Camera photo album to select which photo appears on the top screen.



Nintendo DSi Camera photo album

Using Game Cards

Starting a Game

- 1 Insert a Game Card in the DS Card slot.
If you have trouble inserting the Game Card, eject it and confirm that it is facing the right direction.
Note: The label should face towards the bottom of the **Nintendo DSi XL**.
IMPORTANT: Do not insert or remove Game Cards or accessories when the power is on.

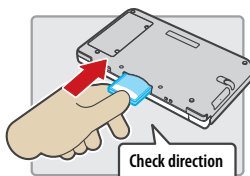

- 2 Press POWER.

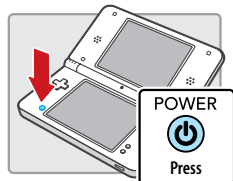

- 3 Tap the Game Card icon.



- 4 Refer to the game's instruction booklet for game play information.

Exiting a Game

- 1 Press and hold POWER.

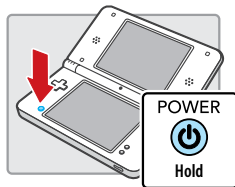

- 2 Press in and then pull out the Game Card.

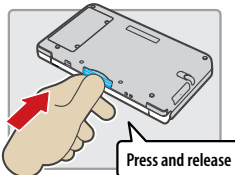

- 3 Store the stylus.

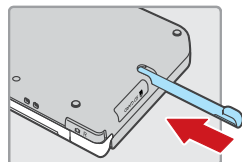

Nintendo DSi Camera

With Nintendo DSi Camera, you can take photos with eleven different lenses, watch slide shows of your photos, and exchange photos with other Nintendo DSi systems.

IMPORTANT: To avoid damage to the Nintendo DSi Camera, do not point it at the sun or other very intense sources of light.



Getting Started

When you start Nintendo DSi Camera, you will have several options available. Tap the Touch Screen to make a selection.

Screen Explanation

Save your photos to the **Nintendo DSi XL** system memory. Save your photos to an SD Card (*).

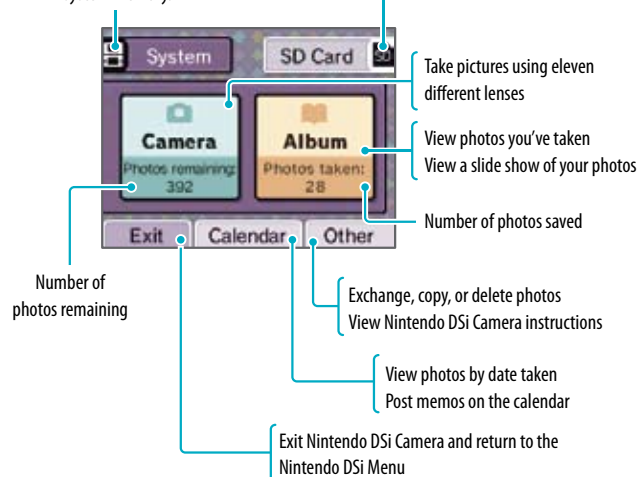

How Many Photos Can I Save?

- Check the Photos Remaining display to see how many photos you can save in your selected location. Because photo-data size can vary, this number is only a rough indicator—it does not reflect a precise number of photos.
- Depending on the size of your SD Card, you can save up to 3,000 photos maximum.

Selecting a Lens

Tap **Camera** from the Nintendo DSi Camera menu to view the lens-selection screen. Tap the lens you want to use, and then tap **Start** to begin using that lens.

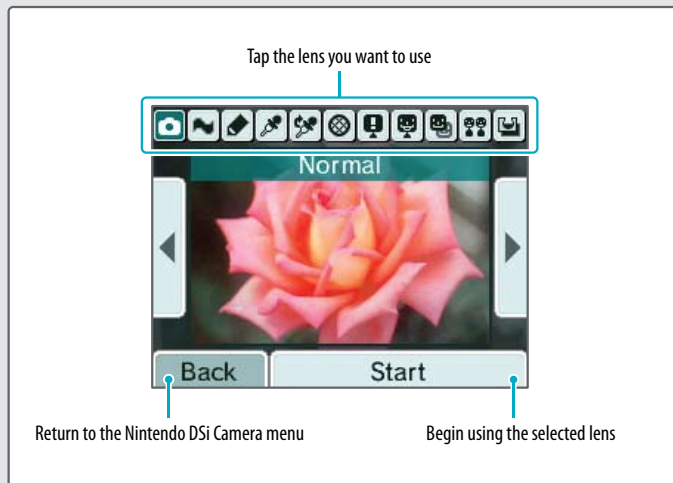

Lens Types

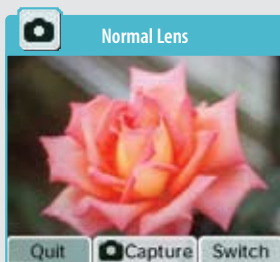

Take photos without any alteration.

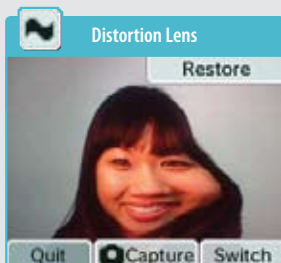

Distort the photo by tapping and sliding on the Touch Screen.

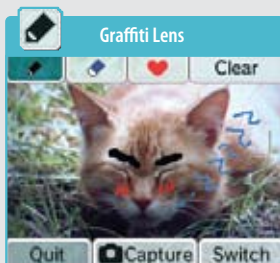

Draw on photos or add colorful stamp designs.

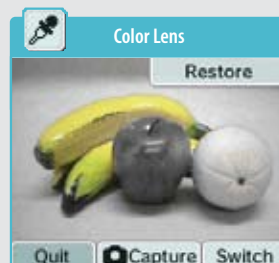

Tap any point on the Touch Screen to restore an area's color to the photo.

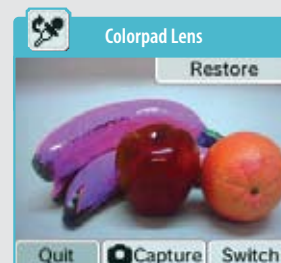

Tap any point on the Touch Screen to alter that color in the photo.

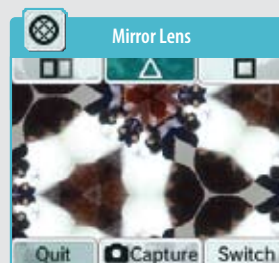

Apply and adjust a variety of mirror effects.

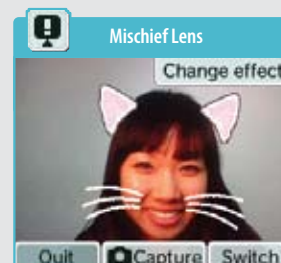

Add a mischievous touch to your friends' faces.

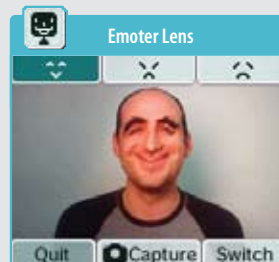

Change facial expressions.

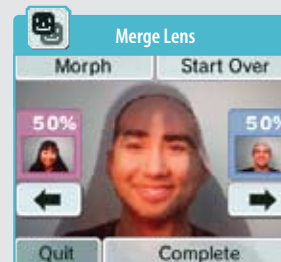

Blend photos of two faces.



Evaluate how similar two faces are.

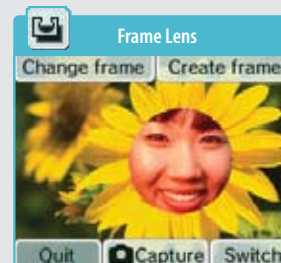

Create frames and take photos within those frames.

Using the Camera (cont.)

Normal Lens

This lens adds no special effects to your photos.

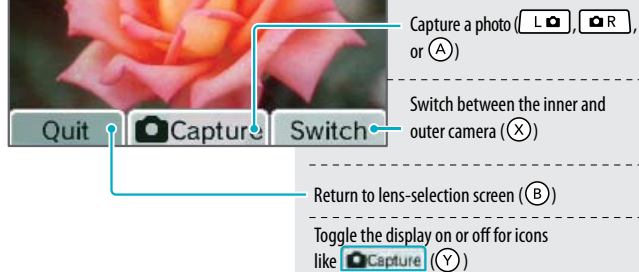

*These controls apply to all lens types
(You can also use the buttons shown in parentheses)*

Distortion Lens

Using this lens, you can slide the stylus on the screen to distort your photo.

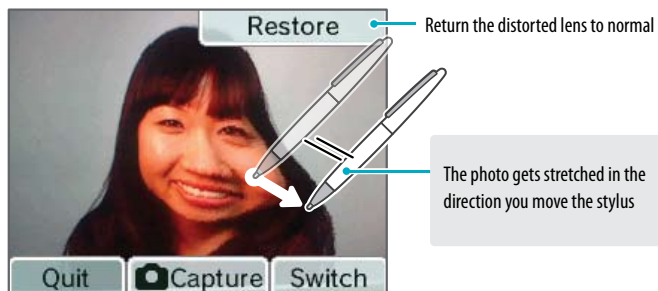

Graffiti lens

Using this lens, you can decorate your photos using pens, stamps, and more.

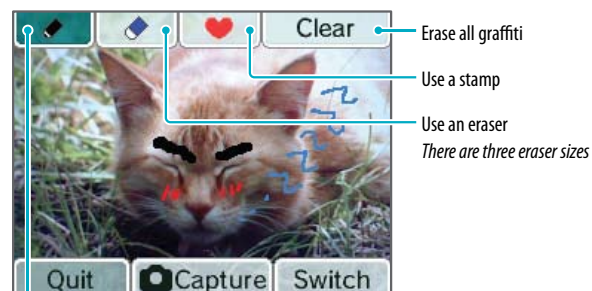

Use pens or droppers (you can select pen color and thickness)
Use the dropper to absorb a color from the screen and use that color as a pen

Using Droppers



1 Select a dropper

2 Tap on a color

3 The pen changes to the color you tapped

Color Lens

This lens converts the image to black-and-white. Tap on an area on the image to restore that color.
The color of areas that were originally black and white will not change.

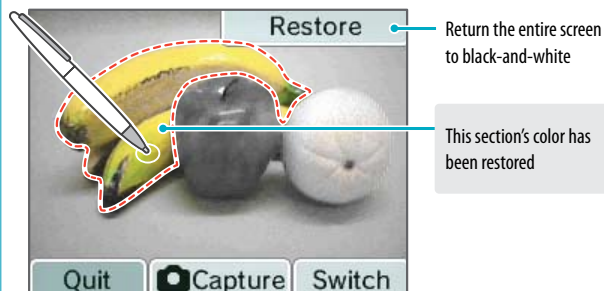

Using the Camera (cont.)



Colorpad Lens

Using this lens, you can change the color of any portion of your photo. The color will change each time you tap. Tapping white, black, or gray areas will not change their color.

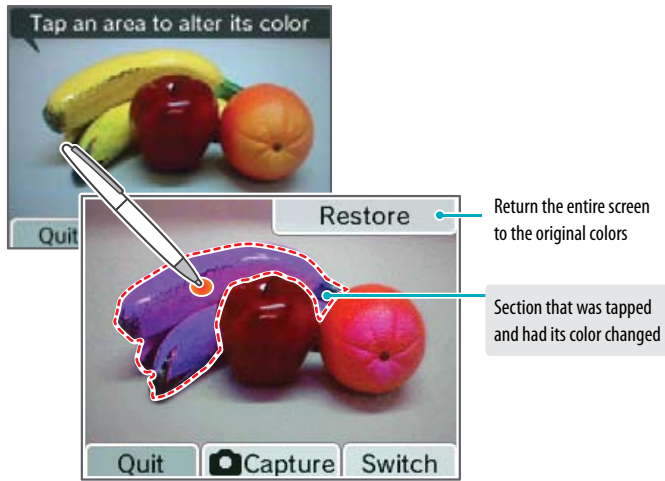

Mirror Lens

Using this lens, you can make your photo look like a kaleidoscope.

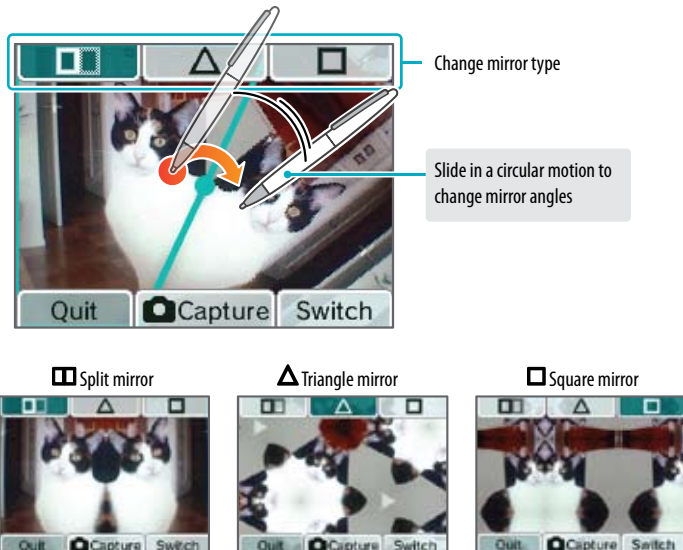

Mischief Lens

Using this lens, you can add special effects to your friends' faces.

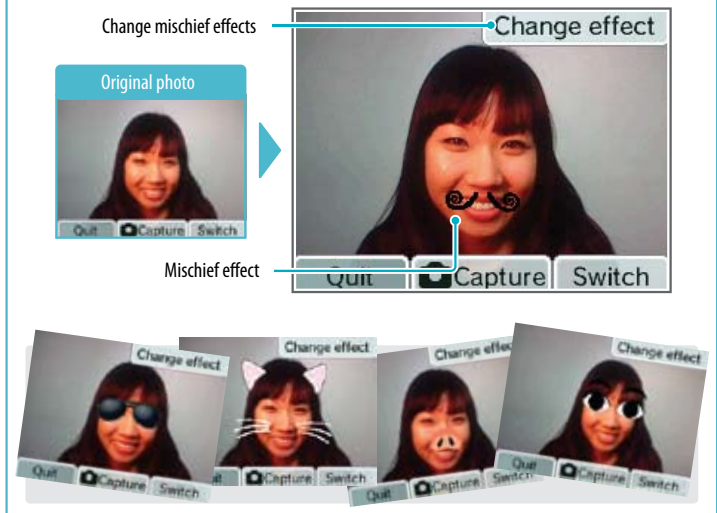

Emoter Lens

Using this lens, you can change the expression on your friends' faces.

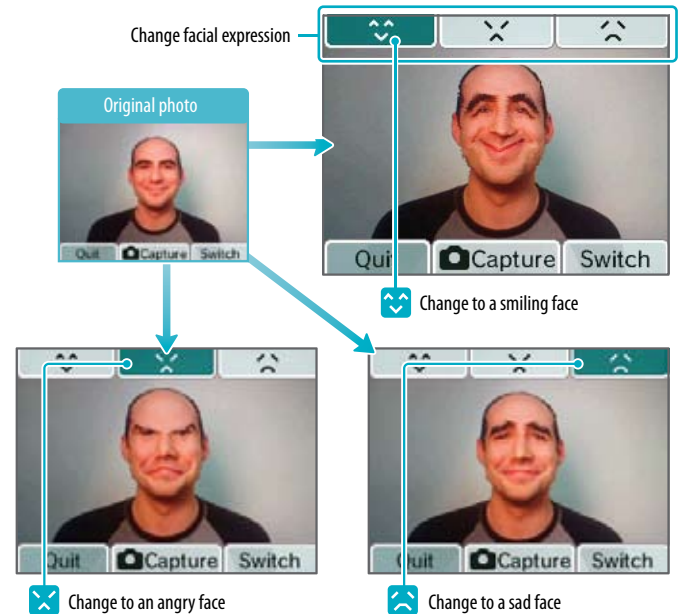

Using the Camera (cont.)

Merge Lens

Using this lens, you can blend two faces together.

- 1 Capture a photo of the first face
Try to get the face as large as possible and centered on the bottom screen.



- 2 Capture the second face as you did the first
It's easier to merge faces if the second face is as close as possible in size and position to the first face.



- 3 Once you have the results of the merge, tap or to change the merge ratio (%) of the two faces



- 4 Tap to save a photo.



Resemblance Lens

Using this lens, you can evaluate how similar two faces are.

- 1 Line up two faces on the screen
Once the faces have been identified, they will appear with square frames around them.

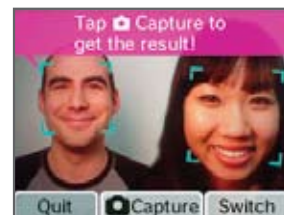

- 2 When the faces have been identified, tap

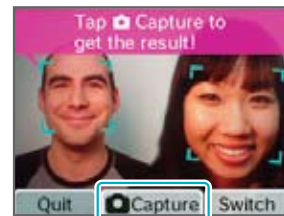

- 3 The similarity percentage will appear, and the photo will be saved



Guidelines Regarding Face Recognition

For more precise facial recognition when using the Mischief, Merge, or Resemblance lenses, pay attention to the following:



Capture photos in a bright environment.



Capture the whole face on screen.



Capture the face from the front.



Don't tilt your head.



Lift bangs to make eyebrows visible.



Take off glasses.

Please keep in mind that following these steps may not ensure perfect facial recognition.

Using the Camera (cont.)



Frame Lens

Using this lens, you can capture photos within preset or user-created frames, or you can create your own brand-new frames.

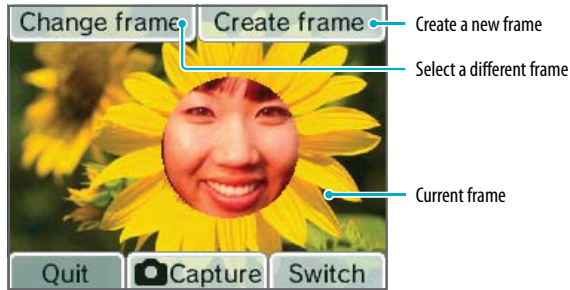

Creating Frames

- 1 Tap **Create frame** on the Touch Screen.



- 2 Select whether to take a new photo to create your frame or to use a photo you've already taken.

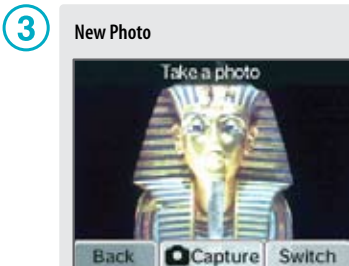
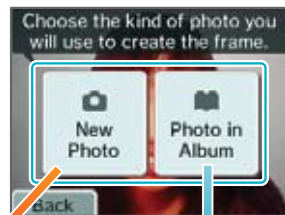

Take a new photo and use it to create a frame.

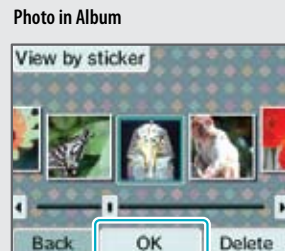

Select a photo from your album and tap **OK**.

- 4 Use the eraser to carve out a blank area in the photo.

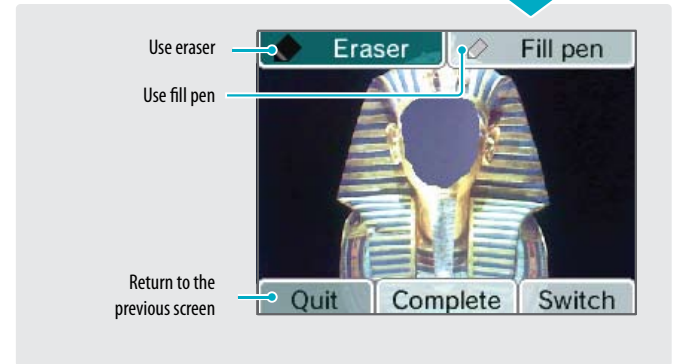

- 5 Tap **Complete** to save your frame.

The completed frame is saved as frame data. You can now select it using **Change frame**. (See step 1).



Now, use the frame you just created and take a new picture with it!



Viewing the Album

Select **Album** from the Nintendo DSi Camera menu to view thumbnails of your photos. You can view, edit, or delete any of the photos you have taken.

View photos you've marked with (★ ★ ★) stickers

View a slide show beginning with the selected photo.

On the selected photo...
Tap → Zoom
Slide → Scroll left or right through thumbnails

Upload selected photographs to Facebook™.

- You must sign up with Facebook before you can upload photos.
- To delete uploaded photos, access Facebook.

Delete the selected photo

Edit the selected photo using a lens

Scroll left or right through photo thumbnails

Return to the Nintendo DSi Camera menu

★ ★ ★ Stickers

You can apply a variety of stickers (★ ★ ★) to your photos to help organize them.

- Photos with ★ stickers will appear on the top screen in the Nintendo DSi Menu.
- Photos captured from the Nintendo DSi Menu automatically receive a ★ sticker.

Slide Show

Select **Slide Show** from the Album menu to display photos one after another. Tap the Touch Screen to activate the Slide Show options shown below.

End slide show

Change display order, display method, and music

Pause/Continue slide show

Options on the Touch Screen

Slide-Show Settings

Change the order of photo display
In order... Display in the order shown in the album
Random... Display in random order

Change the display method

Change the music

Finalize settings and return to slide show

About Facebook

Facebook is a service that helps users connect and share with the people in their life. Millions of people use Facebook everyday to keep up with friends, upload an unlimited number of photos, share links and videos, and learn more about the people they meet. For more information and to learn how to sign up, go to www.facebook.com.

Facebook is a trademark of Facebook, Inc.

About the Thumbnails

- Photos are displayed from left to right in order of oldest to newest. When using **View by sticker**, photos are displayed from left to right in the order in which stickers were applied.
- Photos with file formats that cannot be displayed will have a icon.
- If you have a lot of photos, it might take a while for all of their thumbnails to appear.

Displaying Photos on the Nintendo DSi Menu

- Only photos labeled with a sticker will appear on the top screen of the Nintendo DSi Menu. Apply a sticker to any photos you want to display in menu. Remove stickers from any photos you do not want to appear in the menu.
- Only photographs captured by the Nintendo DSi Camera or the Nintendo DSi Menu camera mode are displayed on the Nintendo DSi Menu. You can apply stickers to photos that were captured by other software, but they will not be displayed on the Nintendo DSi Menu.

Photo Data

- Only photos taken with a Nintendo DSi can be displayed or edited in Nintendo DSi Camera. Photos taken with a digital camera or mobile phone cannot be displayed, nor can photos captured on a Nintendo DSi if they have been copied to an SD Card and then edited on a PC or other device, or renamed.
- Photos taken on a Nintendo DSi contain thumbnail data and photo data. Editing the photos on a PC or other device does not guarantee that the thumbnail data will reflect those changes. As a result, third parties may be able to view unedited thumbnail data if altered photos are uploaded to the Internet. Photos modified on a Nintendo DSi system reflect those changes in their thumbnails.

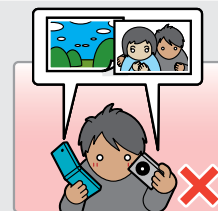

Other Camera Features

Select **Other** from the Nintendo DSi Camera menu to exchange, copy, or delete photos or frames. You can also delete memos here.

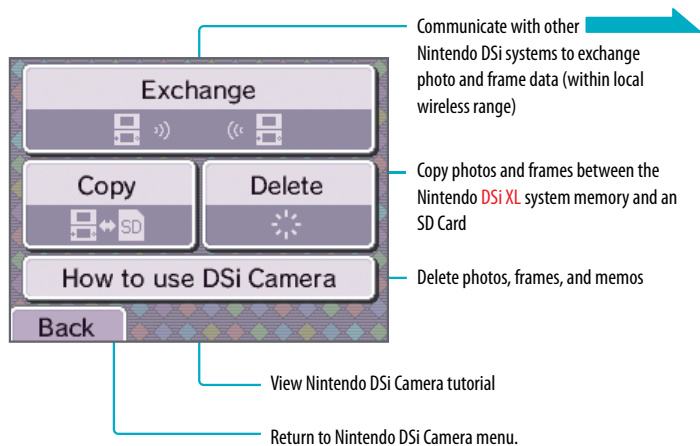

Note: The photos you send may be modified, forwarded and /or posted by the recipient or a third party. Please do not send any photos that may contain personal information. Parental controls can be set to restrict the exchange of photos. See page 69 for more information.

Exchanging Photos/Frames

Communicate with other Nintendo DSi systems to exchange photos or frames.

Controls for Sending Side

- 1 Tap **Send**.

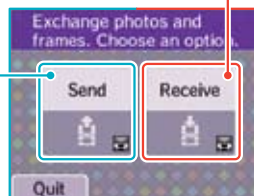

- 2 Wait for the receiving side.

- 3 Select a recipient **1** and then tap **Start** **2**.

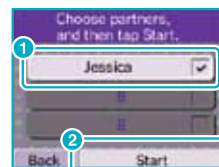

You can send to up to three Nintendo DSi systems at once.

- 4 Select where your photo is located (either **System** for system memory or **SD Card**).

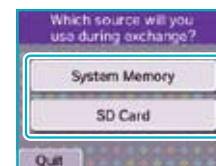

- 5 Select what you want to send.

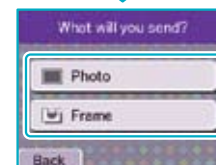

- 6 Select the photo (or frame) to send then tap **Send**.

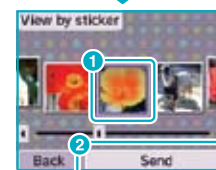

- 7 Select **Yes** when you see the confirmation message.

Controls for Receiving Side

- 1 Tap **Receive**.

- 2 Tap a location to save to.

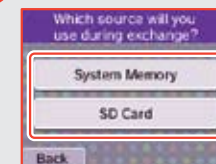

- 3 Tap who you want to receive data from.

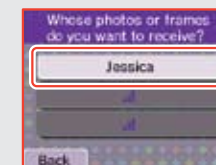

Controls for receiving are finished at this stage.

Copying Photos/Frames

You can copy saved photos and frames from your **Nintendo DSi XL** system to an SD Card or vice versa.

- 1 Select where you want to copy from.

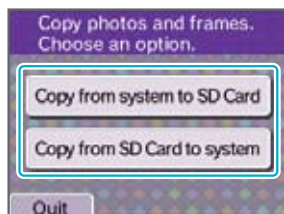

- 2 Select the kind of data you want to copy.

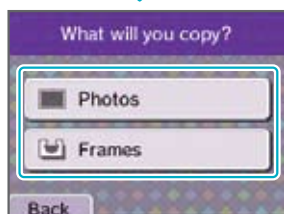

- 3 Select the photos or frames you want to copy.
In this screen, the user has selected to copy photos.



If you select **Copy individually**, you can select a specific photo or frame from the photo album.
In this screen, the user has selected to copy Photos.

Select the photo or frame **1** and then tap **Copy 2**.

Deleting Photos/Frames/Memos

You can delete photos, frames, and memos saved in the system memory or on an SD Card.

- 1 Select where you want to delete from.

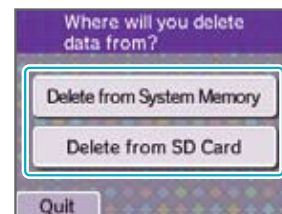

- 2 Select the data you want to delete
In this screen, the user has selected to delete from System. Since memos can be saved only in the system memory, memos will appear only on this screen.

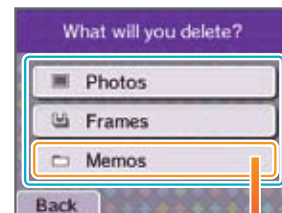

If you select to delete all memos, tap **Yes** on the confirmation screen.

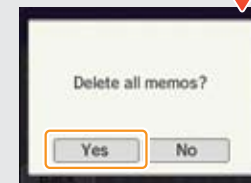

- 3 Select which photos or frames you want to delete
In this screen, the user has selected Photos.

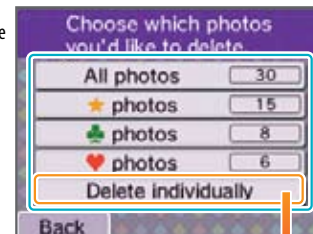

Important:
When you select **All photos** or **sticker photos**, you can quit in the middle of the process, but some photos may still be erased.

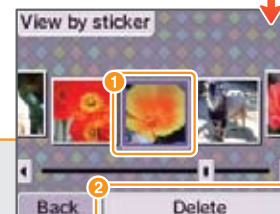

If you select **Delete individually**, you can select a specific photo or frame from the photo album.
In this screen, the user has selected Photos.

Select the photo or frame **1** and then tap **Delete 2**.

Calendar

Select **Calendar** from the Nintendo DSi Camera menu to access the calendar on the Touch Screen.

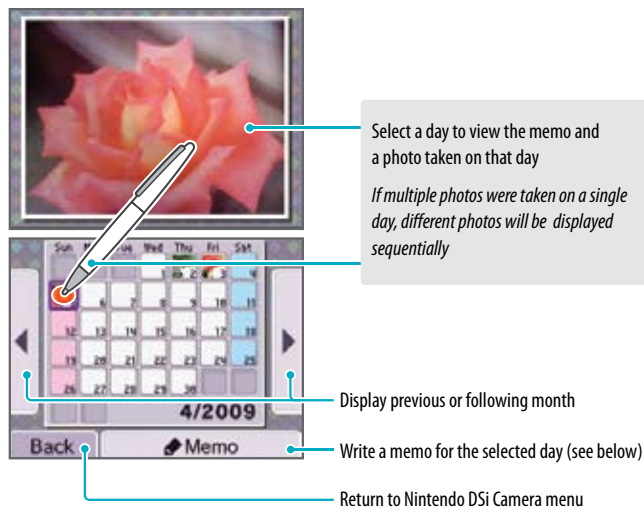

Writing Memos

You can write a handwritten memo for each day, whether it's a note about a special event or a reminder about when those photos were taken. *All memos are saved in system memory.*

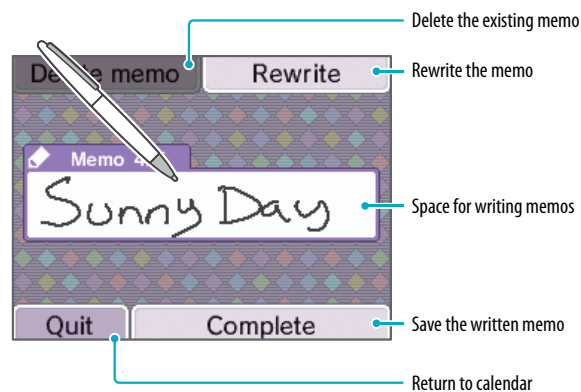

Nintendo DSi Sound

With Nintendo DSi Sound, you can record sounds using the internal microphone and then play with them to create new sounds. You can also play music saved on an SD Card.



Starting Nintendo DSi Sound

When you start Nintendo DSi Sound, you will see a sound wave on the top screen and selectable options on the lower screen. Tap an option to begin playing with sound.

Nintendo DSi Sound Menu

Record sounds with the microphone and play with them (see page 45).

Play with music files* saved on an SD Card (see page 50).

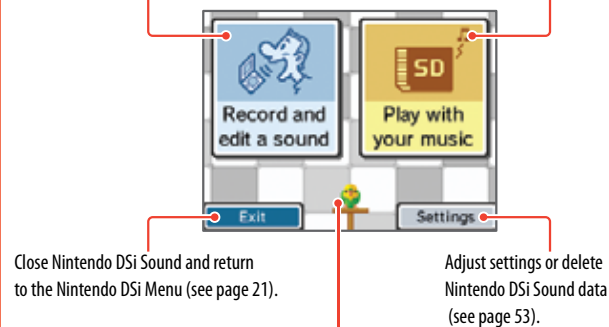

Your parakeet. If you let it listen to voices and sounds around it, it will try to imitate them. It also remembers recordings you've made earlier and may repeat them at random.

*Playable File Formats

The following file formats can be played with Nintendo DSi Sound:

AAC files with .m4a, .mp4, or .3gp filename extensions
 Bitrate: 16 kbps – 320 kbps
 Sampling rate: 32kHz – 48kHz

- For information on how to save music to an SD Card, see page 53.
- For more information on compatible file formats, visit support.nintendo.com.

Recording and Playing with Sounds

Tap **Record** and edit a sound from the Nintendo DSi Sound menu.

Note: Sound data will be saved in the **Nintendo DSi XL** system memory. No data will be written to or read from your SD card.

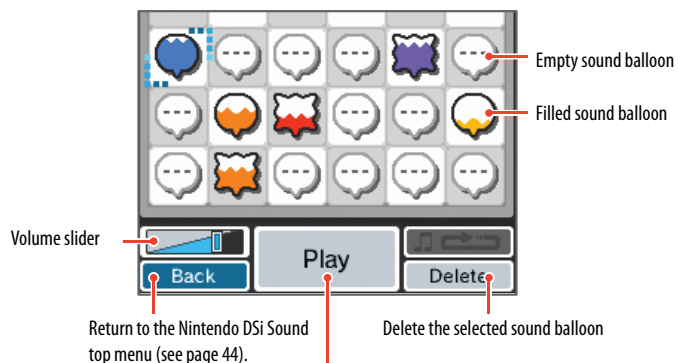

Record sound Use the mic to record a sound. Each balloon can hold up to ten seconds of sound.

Play sound Play with your sounds by changing the playback speed, applying filters, etc. (see page 47).

Moving Data into Different Locations

- 1 Tap the balloon you want to move, and then slide it to where you want it and release.



- 2 The two balloons will swap locations.



Recording

- 1 Tap an empty balloon 1
↓
Tap **Record**. 2



- 2 Tap  to begin recording. If the mic detects a loud enough noise, it will begin recording automatically.



- 3 Once you've finished recording, tap **OK**. Your sound balloon will be whatever color you tap.



Playing with Sound

- 1 Choose the sound balloon you want to use by tapping it 1, then tap Play. 2



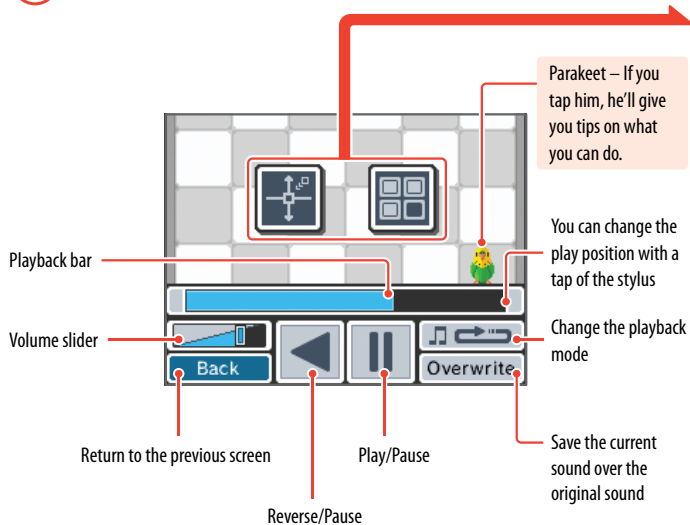

- 2 Change the sound however you like.





Playback Modes

-  Repeat the current sound.

-  Play all sounds in order, then repeat from the beginning.

-  Play the current sound once.

-  Random play.

-  Play the current sound from a user-set point A and point B. Slide points A and B back and forth to adjust them.

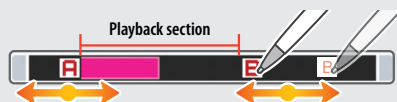

Changing Playback Speed and Pitch

Tap the Touch Screen to move  and alter the speed and pitch of the sound.

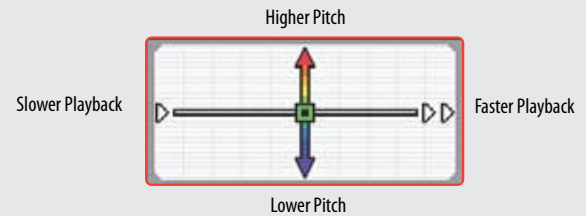

Using Sound Filters

By tapping an icon, you can apply different filters to alter your sound. Each icon has three different filters, so each time you tap one, the filter will change.

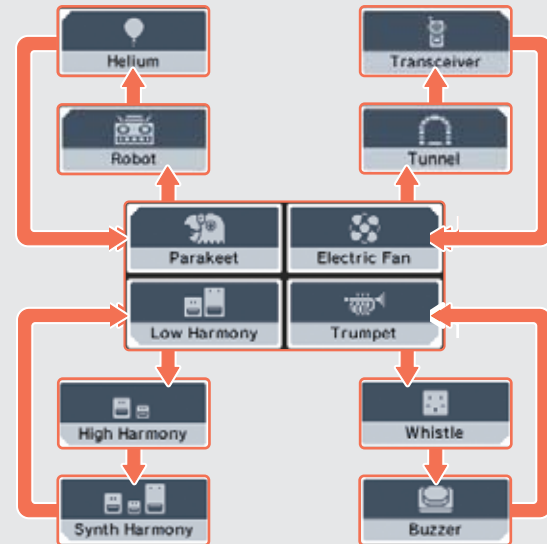

Recording and Playing with Sounds (cont.)

Saving Altered Sounds

- 1 If you want to save sounds that you've changed, tap **Overwrite**.

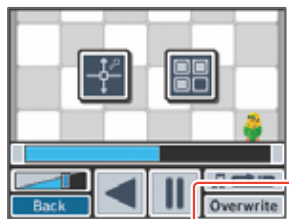

- 2 Confirm that the recording sounds the way you want it.

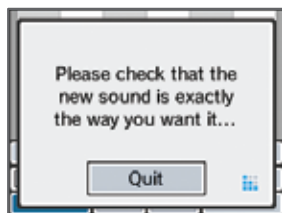

- 3 Tap **OK**.
Your sound balloon will be whatever color you tap.

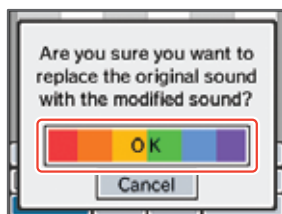

- 4 Your new sound will appear here!



Playing with Music on an SD Card

Choose a Song to Play

- 1 Tap a folder 1, then select **Open**. 2

Select **Auto** to open a random song automatically. You can flag songs as **Top 10**, **Memories**, and so on to add them to your Favorites.

Tap **Clear** to erase all songs from a Favorite folder.

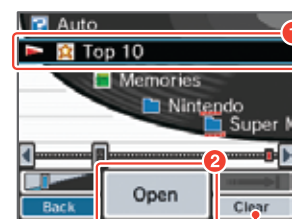

Delete all songs from the selected Favorites folder.

- 2 Touch the song you want to listen to 1 and touch **Start**. 2

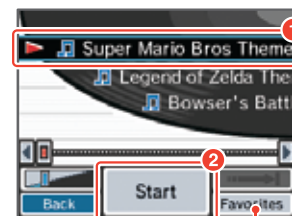

Add the song playing to your favorites.

About Folders and Files on SD Cards

- In Nintendo DSi Sound, only music files and folders containing music files on the SD Card will be displayed. A maximum of 1,000 folders can be displayed.
- If multiple folders on the SD Card have the same name, those song files will all be displayed in one folder with that name.
- Up to 3,000 song files can be displayed.
- Only the first 100 audio files in each folder will be displayed.
- Folders and files more than eight levels deep cannot be displayed.
- Folders will be displayed in numerical/alphabetical order.

Playing with Music Files

Talk to your Parakeet (he'll show you all kinds of things to have fun with)

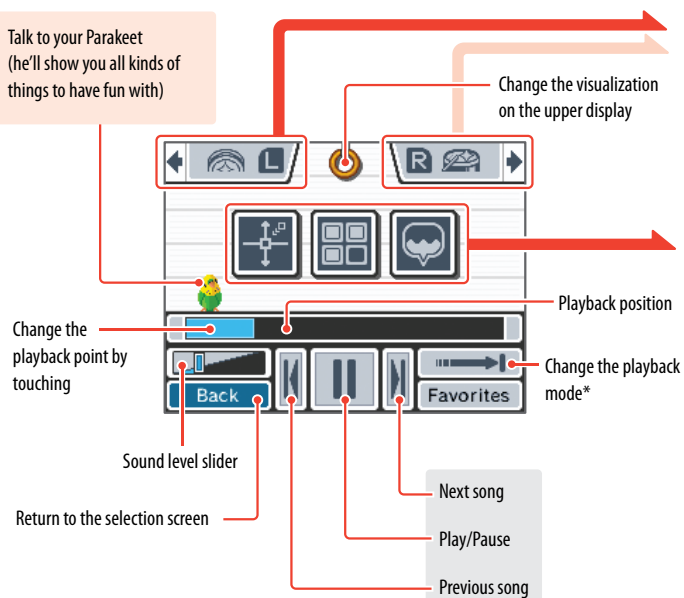

* Playback Modes

Play songs in one folder in order, then stop when finished.

Play songs in the selected folder at random.

Play the current song from a user-set point A and point B. Slide points A and B back and forth to adjust them.

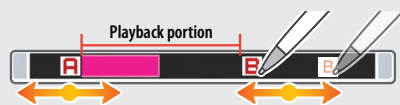

Repeat the current song.

Play the songs in the folder in order, then repeat when finished.

Beat Buttons

Press and to add sound effects. Tap the icons on-screen to change the sound effects.

Change the playback speed and pitch

Touch the screen to move the and adjust the playback speed and pitch.

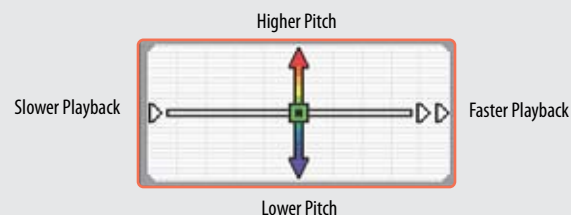
Using filters with the music

Tap each icon to change the filter on the music.

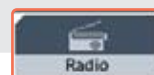

Make music sound like it's being played from an old radio.

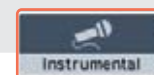

Remove the vocal range from a track, leaving only the instruments. (In some songs, the vocals may not be entirely removed.)

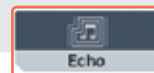

Add an echo effect.

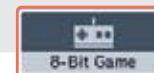

Make your music sound like an old video game!

NOTE: Song or sound files from the SD Card that have been manipulated are not saved.

Layering voice recordings

Tap a sound bubble to start playing it over your music.

Settings

Adjust the settings for Nintendo DSi Sound.

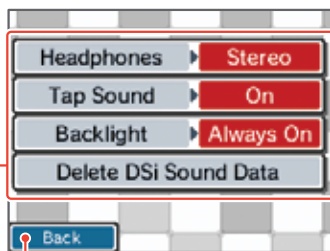

Return to the Nintendo DSi Sound menu (see page 44).

Headphones ▶ Stereo

Set your headphones for mono or stereo.

Tap Sound ▶ On

Enable or disable sound effects when you tap the Touch Screen.

Backlight ▶ Always On

Set the backlight to turn off automatically when Nintendo DSi Sound is not in use.

Delete DSi Sound Data

Erase all Nintendo DSi Sound data from the Nintendo DSi XL system memory. This will erase all sound files you've recorded or modified, any favorites you've assigned to your music, and anything your parakeet might have picked up.

How do you save music files to an SD card?

In order to listen or play with music files, you must save music files on to an SD Card. Please follow the steps below to save music files.

Use the SD Card slot on your computer or a commercially available SD Card reader/writer to place the AAC files on the SD Card.



Nintendo DSi Shop

You can download software onto your Nintendo DSi XL system via Nintendo DSi Shop.



Note: broadband internet access required. For more information, see the section on Internet Setup, beginning on page 73.

Using Nintendo DSi Shop

- To use Nintendo DSi Shop you will need to set up an Internet connection with your Nintendo DSi XL (see page 73), and you will need to have Nintendo DSi Points in your account to download software.

What are Nintendo DSi Points?

You use these points to download Nintendo DSi software from Nintendo DSi Shop.



To add points to your account, you can purchase Nintendo DSi Points online through Nintendo DSi Shop, or you can purchase a Nintendo Points Card™ at select retail locations, which can be redeemed for Nintendo DSi Points in Nintendo DSi Shop. Once redeemed, those points automatically become Nintendo DSi Points and cannot be used on Wii™ console or with any other system.

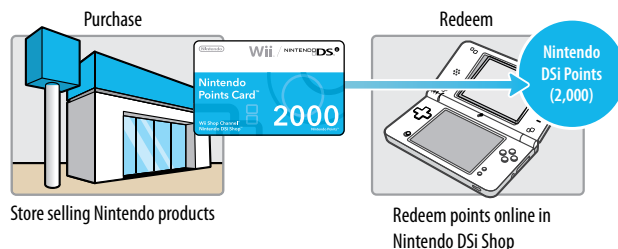

How to Redeem Nintendo DSi Points

There are a number of ways to get Nintendo DSi Points.

Redeem a Nintendo Points Card

- 1 Purchase a Nintendo Points Card.



- 2 Reveal the Nintendo Points Number
Reveal the number on your Nintendo Points Card by scratching off the silver area on the back of the card.

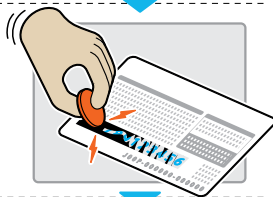

- 3 Start Nintendo DSi Shop

Follow the on-screen instructions to enter the Nintendo Points Number and redeem your Nintendo DSi Points.

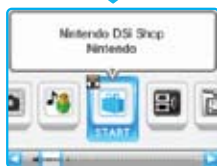

Buy Nintendo DSi Points using a Credit Card

To buy points with a credit card, start the Nintendo DSi Shop and follow the on-screen instructions (you must be 18 or older to use a credit card).



Nintendo DSi Software and Nintendo Points Cards

In order to connect to Nintendo DSi Shop, you will need a broadband Internet connection and a compatible router. The first time you connect, you will need to agree to the terms of the user agreement in order to access Nintendo DSi Shop.

- Nintendo Points Cards sold in the Americas can only be redeemed on Nintendo DSi or Wii systems released in the Americas.
- Your Nintendo DSi Shop account can contain up to 20,000 Nintendo DSi Points maximum at any time.
- You must redeem all of the points on a Nintendo Points Card at once. You cannot divide the points between different systems.
- Parental Controls may be used to restrict use of Nintendo DSi Points and manage downloading of software based on ESRB ratings.
- All Nintendo DSi Points and software downloads are for use only on a single Nintendo DSi system and are nonrefundable and nontransferable.
- Once a Nintendo Points Card has been redeemed for Nintendo DSi Points, it cannot be redeemed on a different Nintendo DSi system or on a Wii console.
- Software downloaded from Nintendo DSi Shop is licensed to you, not sold. For more information, please refer to the user agreement in the System Settings (see page 73).

DS Download Play

With DS Download Play, you can download and play certain multiplayer games with other Nintendo DSi, DS Lite, and DS users even if you have only one copy of a game. You can also send and receive demos of certain software titles.



Control Sequence

Using DS Download Play (Host or sending system)

- 1 On the Nintendo DSi Menu, tap the icon of a DS Download Play-compatible title.



- 2 Now follow the instructions in the instruction booklet of the software you are using.

DS Download Play (Client or receiving system)

- 1 Tap the DS Download Play icon on the Nintendo DSi Menu.



- 2 Select the panel for the game title you want to download.



- 3 Tap Yes to begin downloading the title.



- 4 Now follow the instructions in the instruction booklet of the software you are using.



PictoChat™

PictoChat allows you to use the **Nintendo DSi XL** to send and receive wireless messages and drawings from other Nintendo DSi users. PictoChat is not an Internet application. You can communicate with up to 15 other Nintendo DS users within range of your Nintendo DSi XL. See **PRIVACY INFORMATION** on page 103.



Note: PictoChat works with all models of Nintendo DS.

Starting PictoChat

First, the chat-room selection screen will appear. Select a chat room to join.

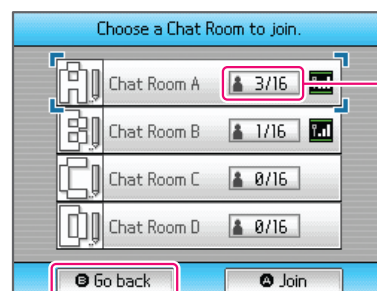

Close PictoChat and return to the Nintendo DSi Menu (see page 21).

The number in each panel indicates how many people are in that chat room. The maximum number of users in each chat room is 16.