

<b>User Manual</b>	
<b><u>Product Name</u></b>	<b><u>ALVH Desktop Card Reader</u></b>
<b><u>Model</u></b>	<b><u>DWMS-VDCR01</u></b>

Version 3.0

March 5,2008

**Miwa Lock Co., Ltd.**

# 1. Introduction

This document describe the supply specifications for the ALVH Desktop Card Reader (VDCR).

The VDCR is a desktop Mifare card reader/writer installed in the hotel and connects to a PC server via RS-232C port.

PC server can write necessary data to the Mifare card which is placed on the VDCR.

The KB/SSDW-05 is a keyboard which also can write the data in the card when installed between the VDCR and the computer.

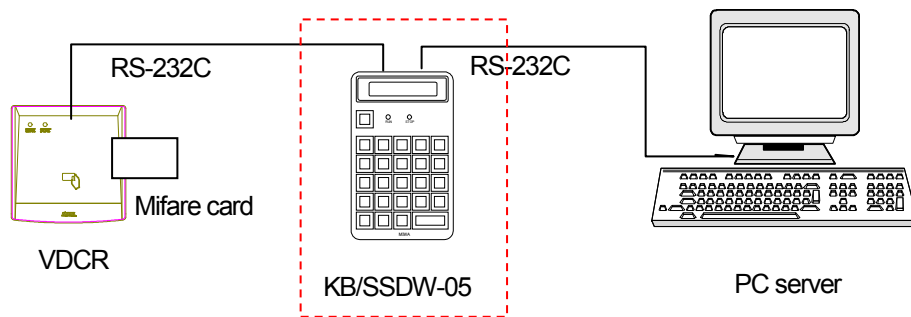

Fig.1.1: Host connection

## 2. Hardware specifications

Table 2.1: Hardware specifications

Items	Description	
General specifications	Weight	225g (Only main unit )      AC power adapter 230g
	Power consumption	13W
General specifications	Temperature/ Humidity	Running temperature      :+0~+40°C / 25~85% (without condensation)
		Storage temperature      : -15~+50°C / 25~85% (without condensation)
	Environment	Room (without excessive dust)
Power source	AC power adapter	Model: 3A-161DA05(MAP ELECTRONICS) Input: 100Vac~240Vac Output: 5Vdc,2.6A Safety standard: UL Electrical standard: CE
Mounting board	Control board (including antenna board)	Performs Mifare card reading/writing MPU:    R8C/Tiny series R5F21258SNFP (Renesas Technology) Running frequency    :20 MHz Built in FROM        :64kbyte+2kbyte Built in RAM         :3kbyte Built in I/F            :2 channels Communication with card: By exclusive chip(RC531) Supply voltage        : 3Vdc
	Communication board	Perform conversion of signal between Control board and external serial interface. Signal level conversion    : RS232C ⇔ TTL Voltage conversion        : 5Vdc⇒3Vdc
	LED board	LED for power source (RUN indication) Color                    : Green Supply voltage        : 5Vdc
	Panel LED board	LED for plane surface illumination (3 colors) and LED for card detection status indication. Lighting Panel        : 6 (3 for upper side of the panel, 3 for lower side of the panel) Illuminated colors :Red / Green / Orange (software control) Status display        : 1 (STS display) Illuminated colors :Red / Green / Orange (software control) Supply used            :5Vdc

### 3. Composition outline

#### 3.1. Outline of system composition

The VDCR composed of the following units.

- 1. VDCR main unit
- 2. AC adapter

Fig. 3.1 shows the top view of the VDCR main unit, and Fig. 3.2 shows arrangement of external interface of the VDCR main unit.

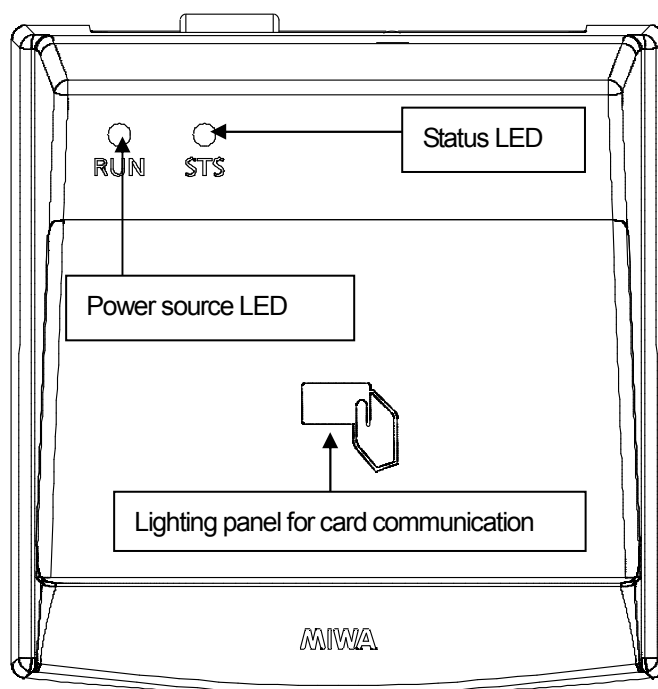

Fig. 3.1 Top view of VDCR main unit

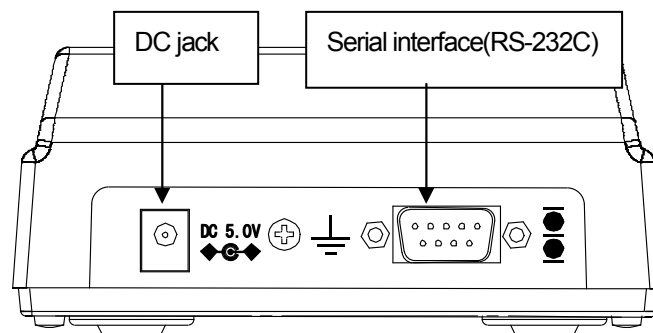

Fig. 3.2 Arrangement of interface panel of VDCR main unit

## 4. Connection to external devices

### 4.1. VDCR main unit

External unit are connected by proper cables to each connector arranged to the posterior interface panel.

- 1. RS-232C : Upper unit (PC server)
- 2. 5Vdc : AC adapter

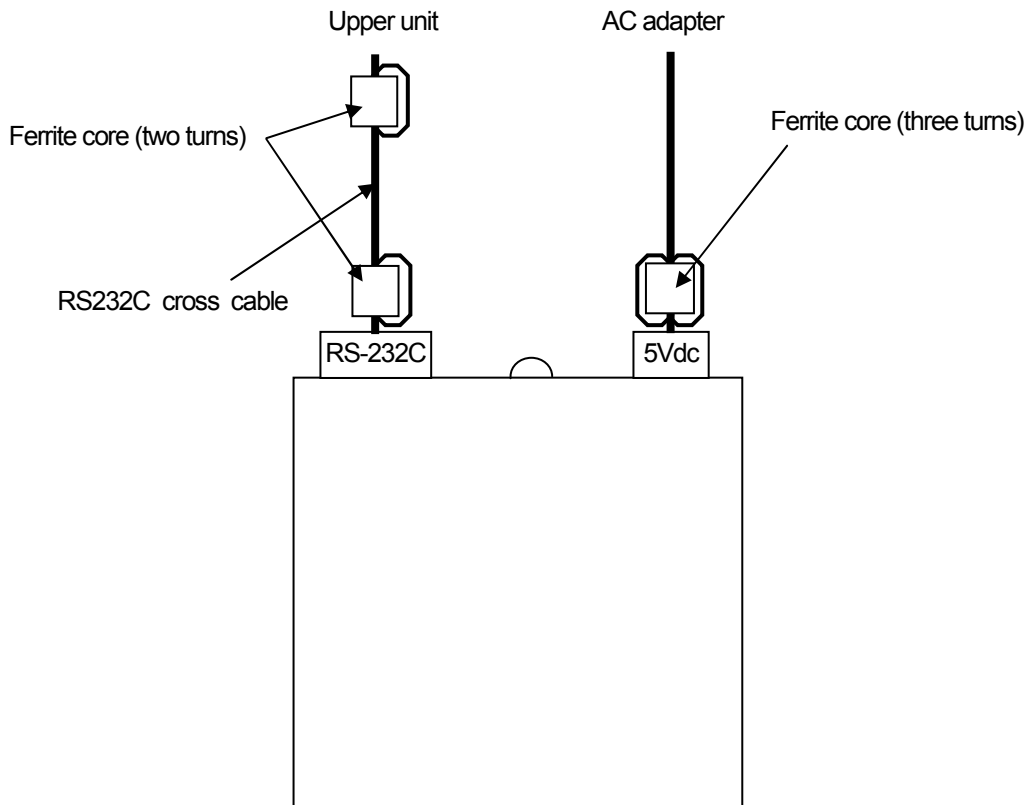
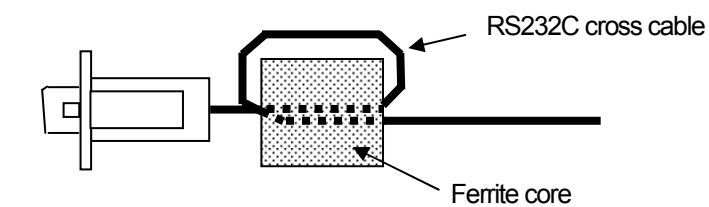

Fig.4.1: External unit connection of VDCR main unit



The cable is turned once and gose through the Ferrite core twice

Fig.4.2: Ferrite core

## 5. VDCR external interface

### 5.1. VDCR main unit external interface

#### 5.1.1. Serial interface (IOIO)

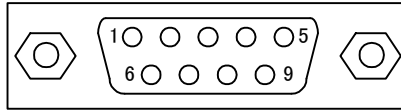

Fig. 5.1: Serial interface

Table 5.1:IOIO connector specifications

Pin No.	Name	Description	I/O
1	N.C.	—	—
2	RX	Received data	I
3	TX	Sent data	O
4	DTR	Data terminal ready	Note 1 O
5	GND	Ground	—
6	DSR	Data set ready	Note 1 I
7	RTS	Send request(Non-connection)	O
8	CTS	Send enable(Non-connection)	I
9	N.C.	—	—

Connector used  
 Model name: EJEY-9P-1F3F-113      Manufacturer: J.S.T Mfg Co., Ltd.

Note 1: #4 pin (DTR) and #6 pin (DSR) are shorted on the control board.

#### 5.1.2. Power supply interface

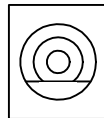

Fig. 5.2: Power supply interface (DC jack)

Table 5.2: Specification of AC power adapter plug

Inner diameter	Outer diameter	Length	Unit
#1 1.7	#2 4.0	#3 9.5	mm
5Vdc 2.6A			

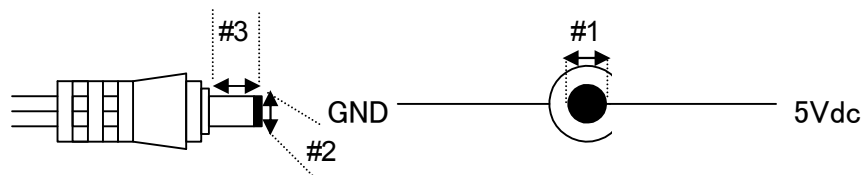

Fig. 6.3 :Specification of AC power adapter

## 5.2. Condition of Mifare card communication

The Mifare card can communicate up to 12mm from lighting panel surface, under the following conditions:

- Condition1 When the applied card is a MARS compatible card, and a single card is held up.
- Condition2 Center of the applied card surface is less than 5mm in horizontal direction from the center of the lighting panel surface.
- Condition3 The lighting panel surface and applied card surface are parallel to each other.
- Condition4 There are no obstruction to electromagnetic waves (13.56MHz) between the lighting panel surface and the applied card.
- Condition5 There are no obstruction to electromagnetic waves (13.56MHz) within 12mm of the VDCR main unit.

Fig. 5.4 Shows the communication range of the Mifare card.

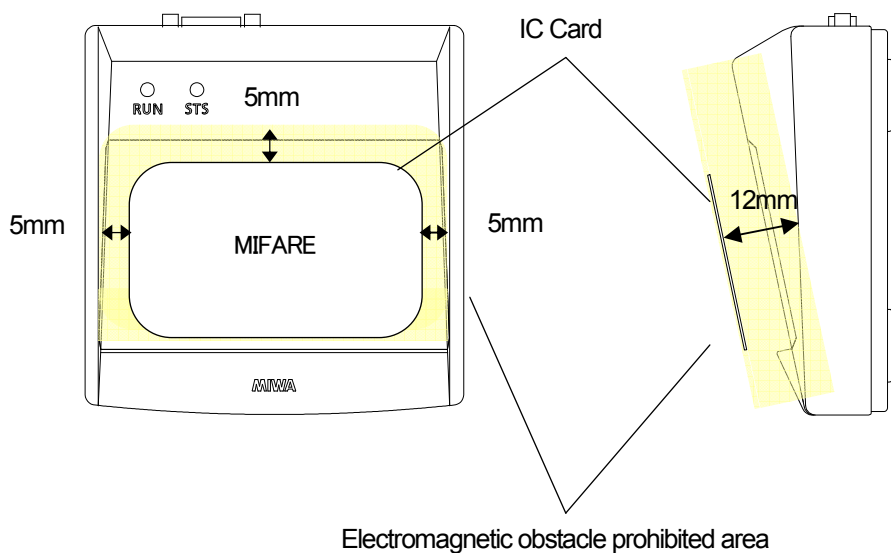

Fig. 5.4: Card communication range

## 6. Regulatory Compliance

### 6-1. USA-Federal Communications Commission (FCC)

This unit has been tested and found to comply with the limits for a Class B digital device, pursuant to Part 15 of the FCC rules. These limits are designed to provide reasonable protection against harmful interference in a residential installation. This unit generates, uses, and can radiate radio frequency energy and, if not installed and used in accordance with the instructions, may cause harmful interference to radio communications. However, there is no guarantee that interference will not occur in a particular installation. If this unit does cause harmful interference to radio or television reception, which can be determined by turning the unit off and on, the user is encouraged to try to correct the interference by one or more of the following measures:

- Reorient or relocate the receiving antenna.
- Increase the separation between the unit and receiver.
- Connect the unit into an outlet on a circuit different from that to which the receiver is connected.
- Consult the dealer or an experienced radio/TV technician for help.

This unit complies with Part 15 of the FCC Rules. Operation is subject to the following two conditions:

(1) This unit may not cause harmful interference, and (2) This unit must accept any interference received, including interference that may cause undesired operation.

#### Caution:

Any changes or modifications not expressly approved by the party responsible for product compliance could void the user's authority to operate the unit.

#### Labelling

MIWA LOCK ALVH Desktop Card Reader is labelled as below.

FCC ID: VBU –DWMS-VDCR01

#### FCC Portion

Federal Communication Commission Declaraton of Conformity (Doc)Statement

**FC** FCC ID:VBU-DWMS-VDCR01

Model No: DWMS-VDCR01

Trade Name	ALVH Desktop Card Reader
Responsible Party	MIWA LOCK CO.,LTD.
Address	3-1-12,Shiba, Minato-ku,Tokyo 105-8510,Japan
Telephon No	+81-3-3452-1465