

ND51

User's Manual
TABLET PC

Content

Copyright Notice	1-3
Trademarks	1-3
Revision History	1-3
FCC-B Radio Frequency Interference Statement	1-4
FCC Conditions.....	1-4
FCC RF Radiation Exposure and SAR Statements	1-5
WEEE Statement.....	1-6
Safety Instructions.....	1-7
Introductions.....	2-1
Unpacking.....	2-2
Product Overview	2-3
Open View	2-3
Top Side View.....	2-5
Right Side View.....	2-6
Left Side View.....	2-8
Rear Side View.....	2-9
Rear Side Disassembled Exploded View.....	2-11
Bottom Side View.....	2-12
Specifications.....	2-13
Getting Started.....	3-1
Begin to Use the Tablet PC.....	3-2
How to Manage Power Supply	3-3
AC/DC Adapter.....	3-3
Battery.....	3-4
Power On	3-5

Copyright Notice

We take every care in the preparation of this document, but no guarantee is given as to the correctness of its contents. Our products are under continual improvement and we reserve the right to make changes without notice.

Trademarks

All trademarks are the properties of their respective owners.

Revision History

- ▶ Version: 2.0
- ▶ Date: 10, 2017

FCC-B Radio Frequency Interference Statement

This equipment has been tested and found to comply with the limits for a Class B digital device, pursuant to part 15 of the FCC rules. These limits are designed to provide reasonable protection against harmful interference in a residential installation. This equipment generates, uses and radiates radio frequency energy, and, if not installed and used in accordance with the instructions, may cause harmful interference to radio communications. However, there is no guarantee that interference will not occur in a particular installation. If this equipment does cause harmful interference to radio or television reception, which can be determined by turning the equipment off and on, the user is encouraged to try to correct the interference by one or more of the following measures:

- ▶ Reorient or relocate the receiving antenna.
- ▶ Increase the separation between the equipment and receiver.
- ▶ Connect the equipment into an outlet on a circuit different from that to which the receiver is connected.
- ▶ Consult the dealer or an experienced radio TV technician for help.

NOTE

- ▶ The changes or modifications not expressly approved by the party responsible for compliance could void the user's authority to operate the equipment.
- ▶ Shield interface cables and AC power cord, if any, must be used in order to comply with the emission limits.

FCC Conditions

This device complies with part 15 of the FCC Rules. Operation is subject to the following two conditions:

- ▶ This device may not cause harmful interference.
- ▶ This device must accept any interference received, including interference that may cause undesired operation.

FCC RF Radiation Exposure and SAR Statements

This device complies with Industry Canada RSS standard(s). Operation is subject to the following two conditions: (1) this device may not cause interference, and (2) this device must accept any interference, including interference that may cause undesired operation of the device.

Le présent appareil est conforme aux CNR d'Industrie Canada applicables aux appareils radio exempts de licence. L'exploitation est autorisée aux deux conditions suivantes:

(1) il ne doit pas produire de brouillage et

(2) l'utilisateur du dispositif doit être prêt à accepter tout brouillage radioélectrique reçu, même si ce brouillage est susceptible de compromettre le fonctionnement du dispositif.

FCC/IC RF Radiation Exposure and SAR Statements SAR Statement. The tablet has been tested for body-worn Specific Absorption Rate (SAR) compliance. The FCC/IC has established detailed SAR requirements and has established that these requirements. RF Exposure Information The radio module has been evaluated under FCC Bulletin OET 65C (01-01)/RSS102 and found to be compliant to RF Exposure from radio frequency devices. This model meets the applicable government requirements for exposure to radio frequency waves. The highest reported SAR level for usage near the body (0mm) is 1.13 W/kg, and for the simultaneous transmission is 1.50W/kg.

- ▶ WiFi 5G indoor use only
- ▶ Operations in the 5.15-5.25GHz band are restricted to indoor usage only

CE Conformity



This device is in compliance with the essential safety requirements and other relevant provisions set out in the European Directive.

Battery Regulations



European Union: Batteries, battery packs, and accumulators should not be disposed of as unsorted household waste. Please use the public collection system to return, recycle, or treat them in compliance with the local regulations.



廢電池請回收

Taiwan: For better environmental protection, waste batteries should be collected separately for recycling or special disposal.

California, USA: The button cell battery may contain perchlorate material and requires special handling when recycled or disposed of in California.

For further information please visit: <http://www.dtsc.ca.gov/hazardouswaste/perchlorate/>

Safety Guideline for Using Lithium Battery

Danger of explosion if battery is incorrectly replaced. Replace only with the same or equivalent type recommended by the equipment manufacturer. Discard used batteries according to manufacturer's instructions.

WEEE Statement



European Union: Under the European Union ("EU") Directive on Waste Electrical and Electronic Equipment, Directive 2002/96/EC, which takes effect on August 13, 2005, products of "electrical and electronic equipment" cannot be discarded as municipal waste anymore and manufacturers of covered electronic equipment will be obliged to take back such products at the end of their useful life.

Safety Instructions



Read the safety instructions carefully and thoroughly. All cautions and warnings on the equipment or user's manual should be noted.



Keep this equipment away from humidity and high temperature.



Lay this equipment on a stable surface before setting it up.



The openings on the enclosure are used for air convection and to prevent the equipment from overheating. Do not cover the openings.



- Do not leave the equipment in an unconditioned environment with a storage temperature above 60°C (140°F) or below -20°C (-4°F), which may damage the equipment.
- This unit should be operation under maximum ambient temperature of 50°C (120°F) or under 60°C (140°F) for light loading applications.

- The storage temperature of battery is -20°C ~45°C if the storage duration is within 3 month.
- The storage temperature of battery must be kept as 23°C if the storage duration is longer than 3 month.
- The recommend battery Storage condition.

Battery capacity keep 30 ± 5%.

Humidity range keep 65 ± 20% RH



Storage Temperature:

23°C± 2°C less than 1 year / -20°C ~ 45°C less than 3 months

- Battery Charging temperature is 10°C ~45°C .
- Battery discharging temperature is -20°C ~60°C .
- The temperature of the maximum battery discharging performance will be 25°C .

Notice: Please do not charge battery in temperature below 0°C or Above 45°C , it may cause safety issue.



- Make sure the power voltage is within safety range and has been adjusted properly to the value of 100~240V before connecting the equipment to the power outlet.
- Always unplug the AC power cord before installing any add-on card or module to the equipment.
- Always disconnect the AC power cord or uninstall the battery pack or switch off the wall socket if the equipment would be left unused for a certain time to achieve zero energy consumption.



Place the power cord in a way that people are unlikely to step on it. Do not place anything on top of the power cord.



Always keep the strong magnetic or electrical objects away from the tablet.



Never pour liquid into the opening that could damage the equipment or cause an electrical shock.



If any of the following situations arises, get the equipment checked by a service personnel:

- The power cord or plug is damaged.
- Liquid has penetrated into the equipment.
- The equipment has been exposed to moisture.
- The equipment has not worked well or you can not get it work according to User's Manual.
- The equipment was dropped and damaged.
- The equipment has obvious signs of breakage.

Green Product Features



- Reduced energy consumption during use and stand-by
- Limited use of substances harmful to the environment and health
- Easily dismantled and recycled
- Reduced use of natural resources by encouraging recycling
- Extended product lifetime through easy upgrades
- Reduced solid waste production through take-back policy

Environmental Policy

- The product has been designed to enable proper reuse of parts and recycling and should not be thrown away at its end of life.
- Users should contact the local authorized point of collection for recycling and disposing of their end-of-life products.

Introductions

User's Manual
TABLET PC

Congratulations on becoming an user of this product, the finely designed Tablet PC. You will have a delightful and professional experience in using this exquisite Tablet PC. We are proud to tell users that this Tablet PC is thoroughly tested and certified by our reputation for unsurpassed dependability and customer satisfaction.

Unpacking

First, unpack the shipping carton and check all items carefully. If any item contained is damaged or missing, please contact your local dealer immediately. Also, keep the box and packing materials in case you need to ship the unit in the future. The package should contain the following items:

- ▶ Tablet PC
- ▶ AC/DC adapter and AC power cord
- ▶ String (optional)
- ▶ Hand strap (optional)
- ▶ Brief case handle (optional)
- ▶ Stylus (optional)
- ▶ Stylus holder (optional)
- ▶ Quick Start Manual(optional)

Product Overview

This section provides the description of basic aspects of the Tablet PC. It will help you to know more about the appearance of this tablet before using it. Please be aware that the figures shown here are for reference only.

Open View

The figure of open view and description shown below will lead you to browse the main operating area of your Tablet PC.



1. Front Camera

This built-in front camera can be used for picture taking, video recording or conferencing, and any other interactive applications.

2. Internal Microphone

This is the built-in microphone and its function is the same with microphone.

3. Touch Screen

Whenever the display is rotated, the touch screen will be rotated and expanded to fit the display automatically.

(NOTE: This function will be changed depends on the user's settings.)

Top Side View

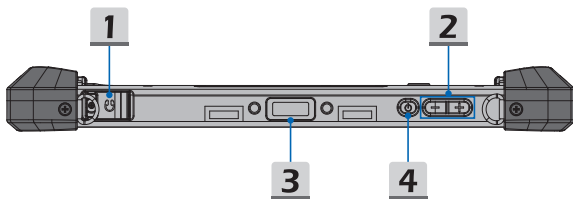

1. Headphone Jack

Used for connecting the speakers or headphones.

2. Volume Up **+** / Volume Down **-** Button

Press the Volume Up or Volume Down button to adjust the sound volume.

3. Barcode scanner (optional)

Easy handheld device for tracking goods from production to loading in the warehouse to ensure shipping and Real-time order status.

4. Power Button



Power

Power Button

- Before powering on the Tablet for the very first time, you must connect it with AC power.
 - Press and hold the power button for 4 seconds can shut down the Tablet.
-

Right Side View

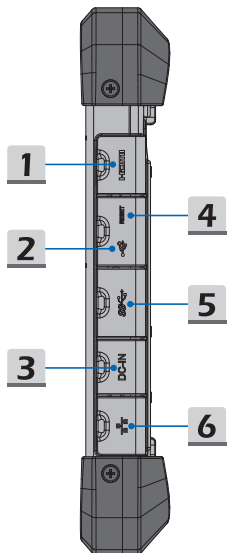

1. **Micro HDMI Port**

Micro HDMI (High-Definition Multimedia Interface) technology is the industry-leading interface and de-facto standard connecting high-definition (HD) equipment.

2. **USB 2.0 Port**

The USB 2.0 port allows you to connect USB-interface peripheral devices, such as the mouse, keyboard, modem, portable hard disk module, printer, etc.

3. **DC-in Jack**

It is an electrical connector for supplying direct current (DC) power.

4. **Reset Hole**

If the Tablet PC cannot be turned off normally or no respond by pressing the power button for 4 seconds, insert a straightened paperclip to the hole.

(Noted: In this case, AC power must be connected before restarting the Tablet.)

5. **USB 3.0 Port**

USB 3.0, the SuperSpeed USB, delivers the higher interface speeds for connecting various devices, such as storage devices, hard drives, or video cameras, and offers more advantages over high-speed data transferring.

6. **RJ-45 Connector**

The Ethernet connector, with bandwidths 10/100 Mbps, is used to connect a LAN cable for network connection.

Left Side View

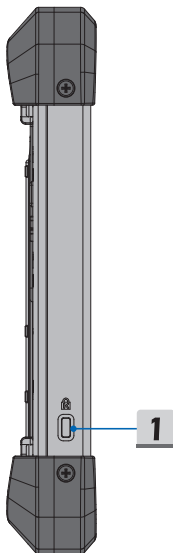

1. Kensington Lock

This tablet provides a Kensington lock hole, which allows users to secure the tablet in place.

Rear Side View

The figure of open view and description shown below will lead you to browse the main operating area of the Tablet PC.

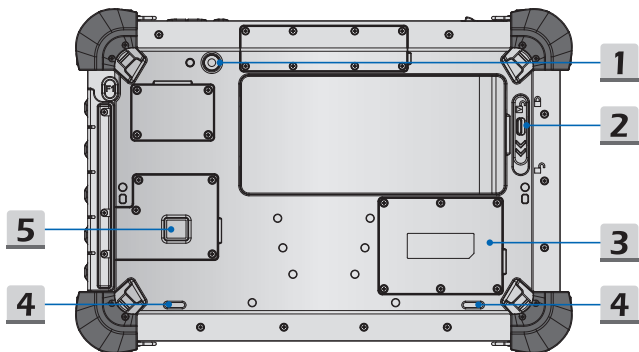

1. Rear Camera

This built-in rear camera can be used for picture taking, video recording or conferencing, and any other interactive applications.

2. Battery latch

To lock/unlock battery.

3. NFC (optional)

To transfer information and files by point-to-point through two device with NFC function.

4. Speaker

Support high quality sound.

5. Finger print (optional)

To access the tablet authority by scanning users' fingerprint.

LTE Card Slot (optional)

To surf Internet with LTE high-speed wireless communication.

Rear Side Disassembled Exploded View

The figure of dismantling view will lead you to browse the Tablet PC.

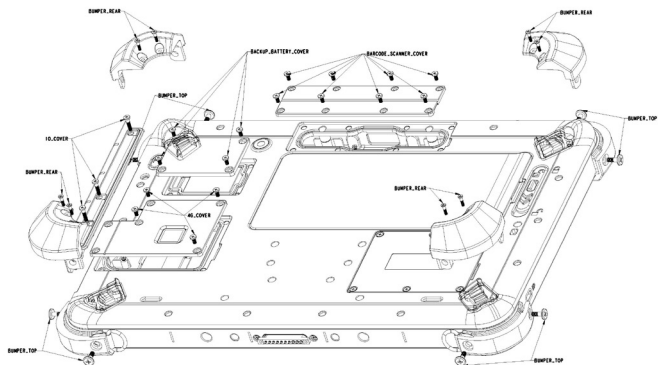

Bottom Side View

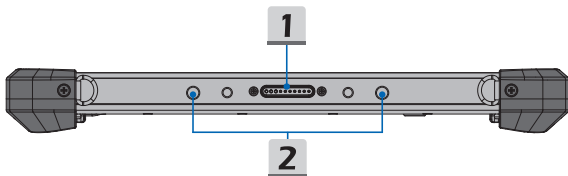

1. Dock Connector



Connect with external Docking Station to increase more I/O functions.

2. Boss Hole

Used for locking the boss hole of the dock.

Specifications

The specifications listed here is reference only, and may change without notice. The actual products sold are different from areas.

Physical Characteristic	
Dimension	283.4(W) x 192.0(H) x 21.9(D) mm
Weight	< 1200 g
CPU	
Processor Type	Intel® Atom™ Processor
Supported Processor	Intel® Quad Core processor
Memory	
Technology	LPDDR3 1600
Memory	4GB/8GB on board
Power	
AC/DC Adapter	65W, 19V Input: 100~240V, 50~60Hz Output: 19V  3.42A 
The supported AC/DC adapter may vary without notice.	
Storage (Note: items listed below may vary without notice)	
EMMC	64GB/128GB
I/O Port	
USB	x 1 (USB 3.0) x 1 (USB 2.0)
Internal Microphone	x 1
Headphone Jack	x 1
DC-in Jack	x 1
Micro HDMI	x 1
RJ45	x 1

Introductions

Kingston Lock	x 1
Pogo Pin	x 1
Sim Card	x 1
SD Card reader	x 1

Communication Port

Wireless LAN	Supported
Bluetooth	Supported

Display

LCD Type	10.1" IPS display
Resolution	1200 x 1920
Multi Touch	10-Point Touch Supported
Brightness	Brightness controlled by setting

Video

Graphics	UMA
----------	-----

Webcam

Front Camera	2.0MP
Rear Camera	8.0MP

Audio

Internal Speakers	x 2
Sound Volume	Adjust by volume button & SW

Optional Function

Barcode scanner	Supported
NFC	Supported
LTE	Supported
Finger print	Supported

The actual function preinstalled in this product depends on the model you purchased, and may vary without notice.

Getting Started

User's Manual
TABLET PC

Begin to Use the Tablet PC

For a new user of this Tablet PC, we would like to suggest you follow the illustrations below to begin to use the Tablet PC.



How to Manage Power Supply

This section provides users basic safety precautions to take when using an AC/DC adapter and battery power properly.

AC/DC Adapter

Ensure that your notebook is connected to an AC power source via the AC adapter before turning it on for the first time. If the notebook automatically shuts down due to low battery power, it is likely to cause system failure. Below are some Dos and Don'ts of an AC/DC adapter.

- ▶ Dos
 - Use the adapter that shipped with your notebook only.
 - Always be aware of heat coming from the in use AC/DC adapter.
 - Unplug the AC power cord before disassembly the notebook.
 - ▶ Don'ts
 - Cover an in-use adapter since it can generate heat.
 - Have the AC power cord plugged after powering off the system when the notebook is going to be left unused for a longer time.
1. Take up the interchangeable plug and look for the groove on the interchangeable plug which can be used for locking on the AC/DC adapter. Then align the groove of the interchangeable plug on the tenon of the AC/DC adapter with correct orientation. Next, rotate the interchangeable plug 90 degrees clockwise until it is fixed on the AC/DC adapter.
 2. Plug the DC end of the AC/DC adapter into the DC-in jack of the Tablet PC.
 3. Then plug the AC/DC adapter into the power outlet.
 4. When remove, please follow the steps 3 2 1.

(NOTE:The interchangeable plug may vary depending on countries or regions.)

Battery

Please follow your local laws and regulations to recycle the Tablet and battery pack.

▶ **Conserving Battery Power**

Efficient battery power is critical to maintain a normal operation. If the battery power is not managed well, the saved data and customized settings may be lost.

To optimize battery life and avoid a sudden power loss, read the tips below:

- Suspend system operation if the system will be idle for a while or shorten the suspend time period.
- Turn off the system if you won't be using it for a period of time.
- Disable unnecessary settings or remove idle peripherals.
- Connect an AC/DC adapter to the system whenever possible.

▶ **Charging the Battery Pack**

The battery pack can be recharged when the Tablet PC is connected to the AC power. Please pay attention to the following tips before recharging the battery:

- You can use the system, suspend system operation or shut down and turn off the system without interrupting the charging process.
- The battery pack uses Lithium-ion Polymer battery cells that have no "memory effect." It is unnecessary to discharge the battery before recharging. However, to optimize the life of battery, we suggest that consuming the battery power completely once a month is necessary.
- The actual charging time will be determined by the applications in use.

▶ **Safety guidelines**

- Danger of explosion if battery is incorrectly replaced. Replace only with the same or equivalent type recommended by the manufacturer. Discard used batteries according to manufacturer's instruction.
- Always keep the Tablet PC and its battery away from excessive moisture and extreme temperatures.
- Always unplug the AC power cord before installing any module to the Tablet PC.

(NOTE: Please do not charge battery in temperature below 0 °C or above 45 °C , it may cause safety issue.)

Power On

Long press the Power Button to power on the Tablet.



