

# **N728'J ctf y ctg'F guli p''**

**LTE Module Series**

**Version: V1.0**

**Date: 2016-09-13**

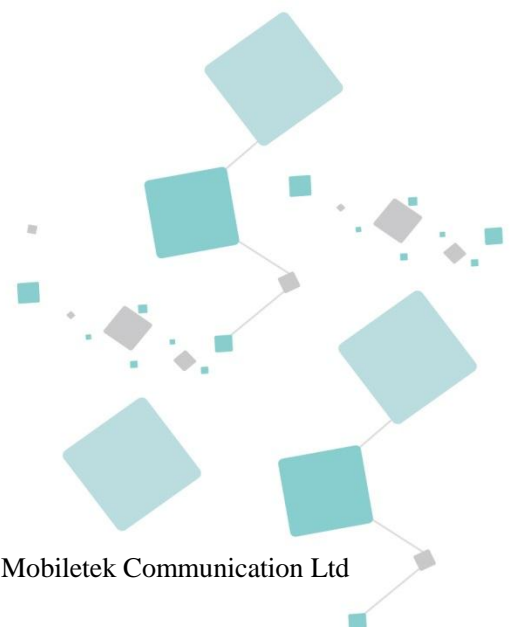

#### Notice

Some features of the product and its accessories described herein rely on the software installed, capacities and settings of local network, and therefore may not be activated or may be limited by local network operators or network service providers.

Thus, the descriptions herein may not exactly match the product or its accessories which you purchase. Shanghai Mobiletek Communication Ltd reserves the right to change or modify any information or specifications contained in this manual without prior notice and without any liability.

#### Copyright

This document contains proprietary technical information which is the property of Shanghai Mobiletek Communication Ltd. copying of this document and giving it to others and the using or communication of the contents thereof, are forbidden without express authority. Offenders are liable to the payment of damages. All rights reserved in the event of grant of patent or the registration of a utility model or design. All specification supplied herein are subject to change without notice at any time.

#### DISCLAIMER

ALL CONTENTS OF THIS MANUAL ARE PROVIDED “AS IS”. EXCEPT AS REQUIRED BY APPLICABLE LAWS, NO WARRANTIES OF ANY KIND, EITHER EXPRESS OR IMPLIED, INCLUDING BUT NOT LIMITED TO, THE IMPLIED WARRANTIES OF MERCHANTABILITY AND FITNESS FOR A PARTICULAR PURPOSE, ARE MADE IN RELATION TO THE ACCURACY, RELIABILITY OR CONTENTS OF THIS MANUAL.

TO THE MAXIMUM EXTENT PERMITTED BY APPLICABLE LAW, IN NO EVENT SHALL SHANGHAI MOBILETEK COMMUNICATION LTD BE LIABLE FOR ANY SPECIAL, INCIDENTAL, INDIRECT, OR CONSEQUENTIAL DAMAGES, OR LOSS OF PROFITS, BUSINESS, REVENUE, DATA, GOODWILL SAVINGS OR ANTICIPATED SAVINGS REGARDLESS OF WHETHER SUCH LOSSES ARE FORSEEABLE OR NOT.

Version History

Date	Version	Description of change	Author
2016-09-13	V1.0	Initial	

# 1 About this document

## 1.1 Applicable scope

This document describes the L506 series 4G LTE LCC Module (hereinafter referred to as L506), the basic specifications, product electrical characteristics, design guidance and hardware interface development guidance. Users need to follow this documentation requirements and guidance for design.

This document applies only to L506 products in the application development.

## 1.2 Writing purpose

This document provides the design and development basis for the product users. By reading this document, users can have a whole understanding of the product, the technical parameters of the product have a clear understanding, and can be used in this document to complete the development of Internet access functions.

This hardware development document not only provides the product functional features and technical parameters, but also provides product reliability testing and related testing standards, business functions to achieve process, RF performance indicators and user circuit design guidance.

## 1.3 Support and reference documents list

In addition to the hardware development documentation, we also provide a guide to the development board based on this product manual and software development instruction manual, 1-1 is supported as a list.

Table 1-1 support document list

No.	Documents
1	《L506 AT Command User Guide》
2	《L506_SPEC.docx》
3	《L506 EVB User Manual》
4	《L506 Schematic checklist》
5	《L506 Layout checklist》
6	《L506_Reference Design_V3.pdf》
7	《L506_V1_DECAL.sch》

## 1.4 Terms and Abbreviations

Table 1-2 is the Document relative Terms and Abbreviations.

Table 1-2 Terms and Abbreviations

Abbreviation	Descriptions
ESD	Electro-Static discharge
USB	Universal Serial Bus
UART	Universal Asynchronous Receiver Transmitter
SDCC	Secure Digital Card Controller
USIM	Universal Subscriber Identification Module
SPI	Serial Peripheral Interface
I2C	Inter-Integrated Circuit
PCM	Pulse-coded Modulation
I/O	Input/output
LED	Light Emitting Diode
GPIO	General-purpose Input/Output
WCDMA	Wideband Code Division Multi Access
UMTS	Universal Mobile Telecommunication System
HSDPA	High Speed Downlink Packet Access
HSUPA	High Speed Uplink Packet Access
AGPS	Assisted Global Positioning System
BER	Bit Error Rate
DL	Downlink
COEX	WLAM/LTE-ISM coexistence
SMPS	Switched-mode power supplies
LTE	Long Term Evolution
FDD	Frequency Division Duplexing
TDD	Time Division Duplexing

---

DPCH	Dedicated Physical Channel
DPCH_Ec	Average energy per PN chip for DPCH. DPCH

## 2 Product Overview

L506 is a series module and design for global market, It include standard series and LD series. User can choose the module based on the wireless network configuration. In this document, the supported radio band is described in the following items. This product is a LCC interface of 4G wireless internet module, with the high speed, small size, light weight, high reliability can be widely used in various products and devices with wireless internet access:

Table 2-1 L506 series module type correspond band

Support band		L506
WCDMA	UMTS850	●
	UMTS1900	●
LTE-FDD	FDD_LTE B2	●
	FDD_LTE B4	●
	FDD_LTE B5	●
	FDD_LTE B13	●
	FDD_LTE B17	●
GNSS	GPS L1 BAND	●
	GLONASS	●
	BEIDOU	●

Table 2-2 Differences list between L506A standard series and L506 LD series

Feature	L506 Standard series	L506 LD series
Voice	YES	NO
GNSS	YES	NO
Diversity reception	YES	NO

### Data transmission specifications

- LTE-FDD
  - Uplink up to 50Mbps,
  - Downlink up to 150Mbps

- HSPA+
  - Uplink up to 5.76 Mbps,
  - Downlink up to 42 Mbps
- UMTS
  - Uplink/Downlink up to 384Kbps

#### Interface

- SUB2.0
- UART
- USIM (3V/1.8V)
- GPIO
- ADC
- SDIO
- PCM
- SPI
- I2C
- NETLIGHT
- POWER KEY
- RESET

Dimensions (L×W×H) : 30mm×30mm×2.8mm



TOP VIEW

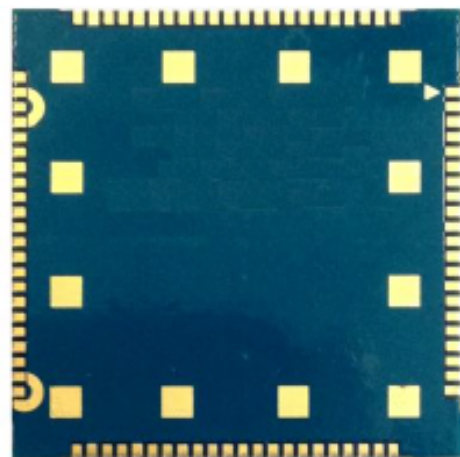

BOTTOM VIEW

Figure 2-1 Product Physical Map

## 2.1 Package Dimensions

The product module is 87-PIN LCC package module, in addition to signal pin, also contains many special heat welding disc to improve joint performance, mechanical strength and heat dissipation



performance, the heat release welding disc 12 and uniform distribution in the bottom of the PCB. Package size is 30 x 30 mm, the height is 2.8 mm. Pin 1 position from the bottom of the belt angle welding plate to identify, the missing corner where the direction of the corresponding module angle pad, figure 2-2 is the product dimension type map:

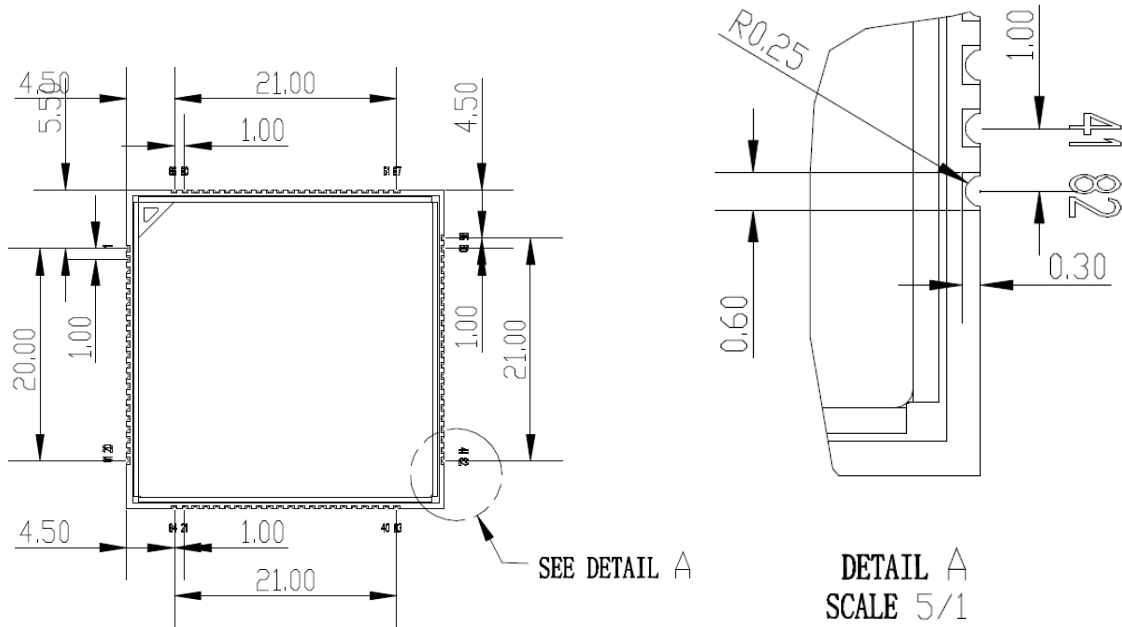

(a) Top Dimensions (Unit mm)

(b) Top Detail (Unit mm)A

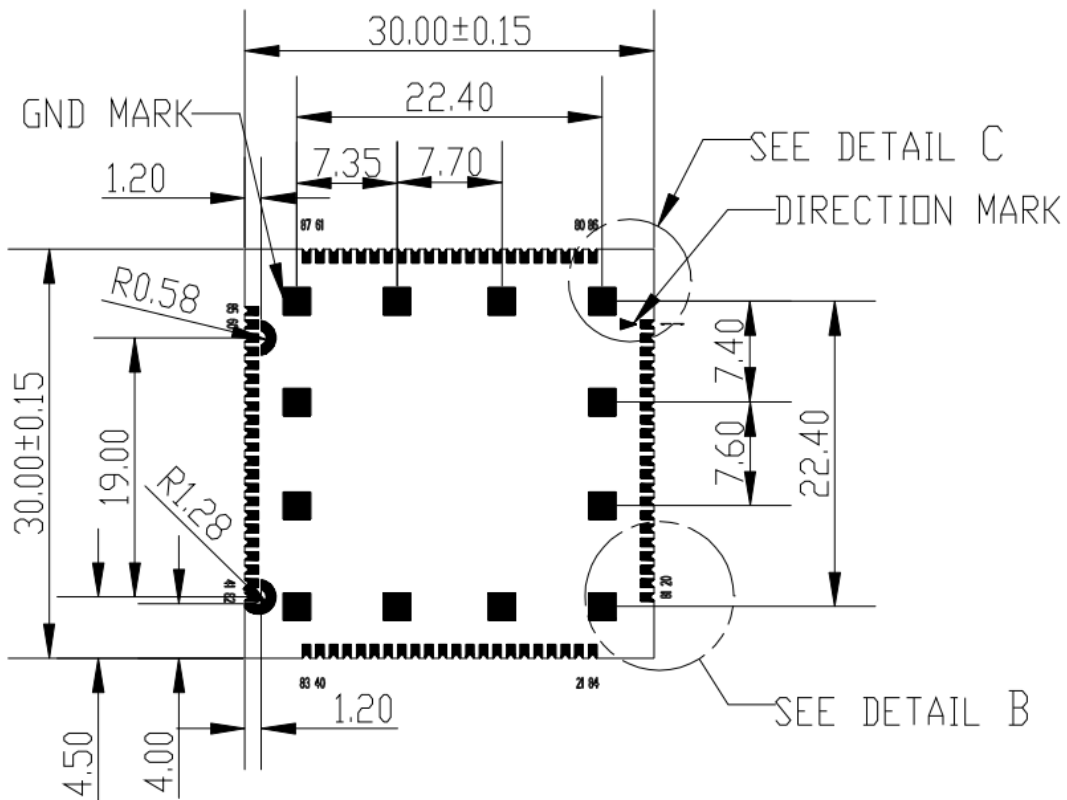

(c)Bottom Dimensions (Unit mm)

*Note: antenna feed point in actual use of the customers don't need (PCB assembly, the stencil file).*

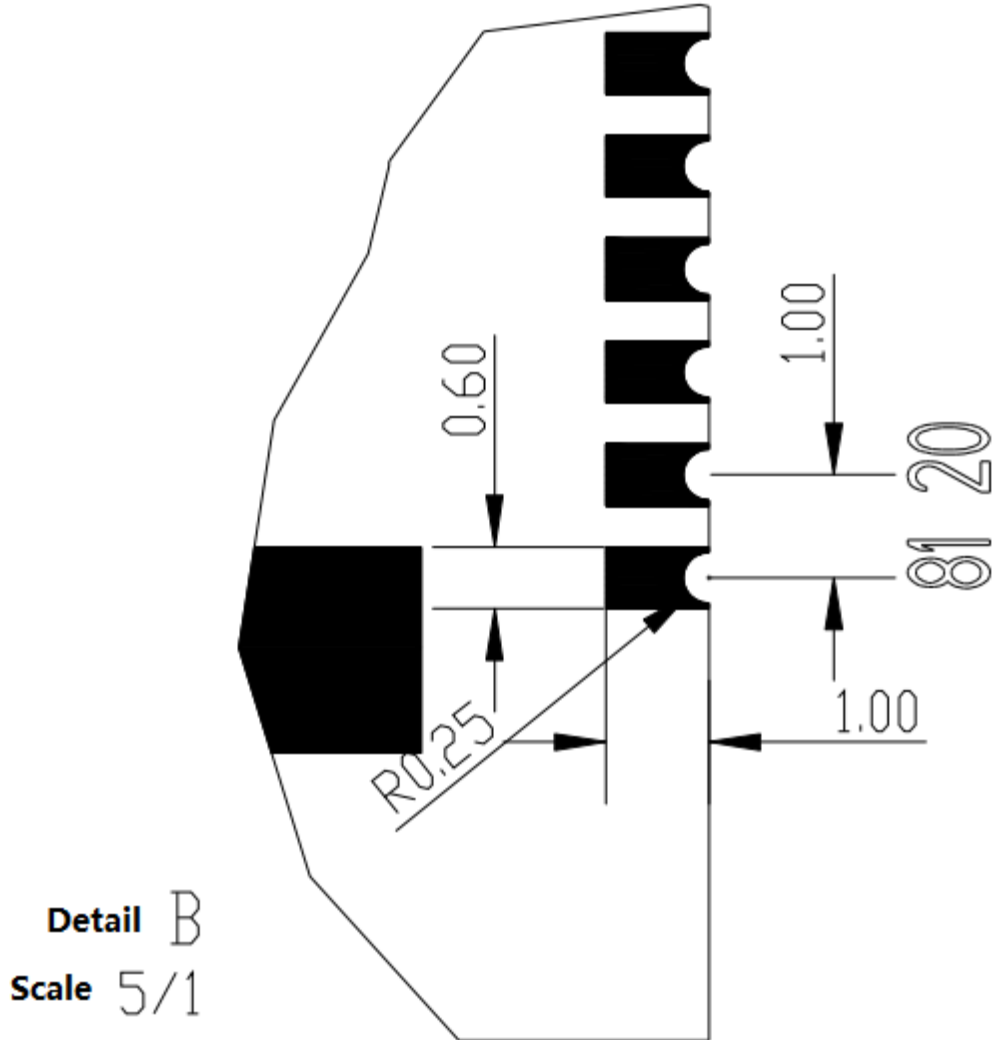

(d)Bottom Detail B (Unit mm)

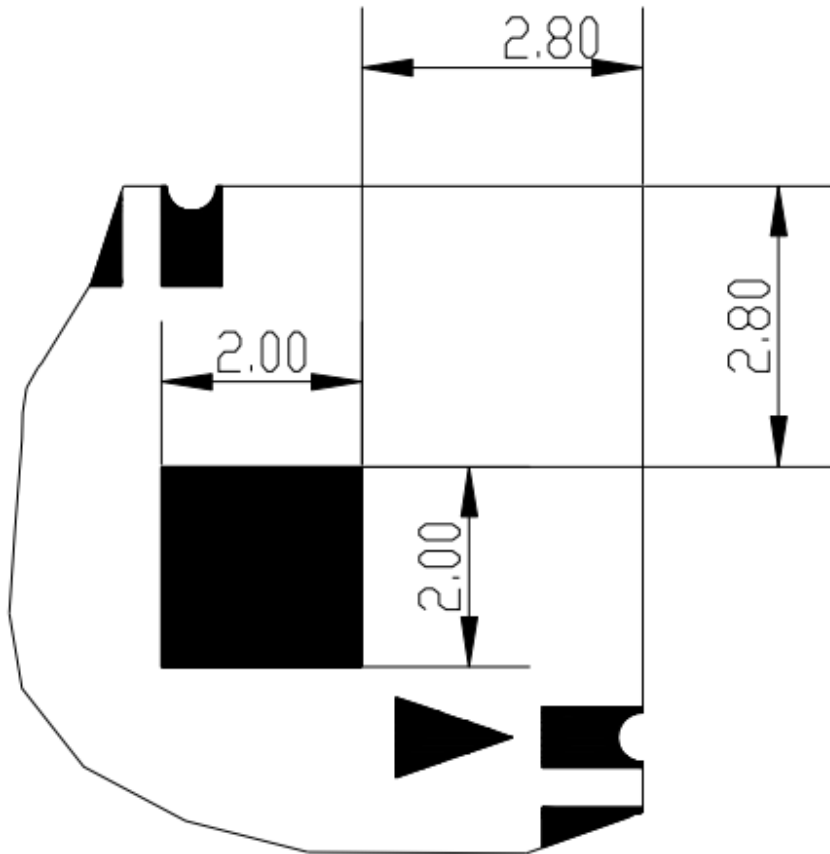

**Detail C**  
**Scale 5/1**

(e)Bottom Detail C (Unit mm)

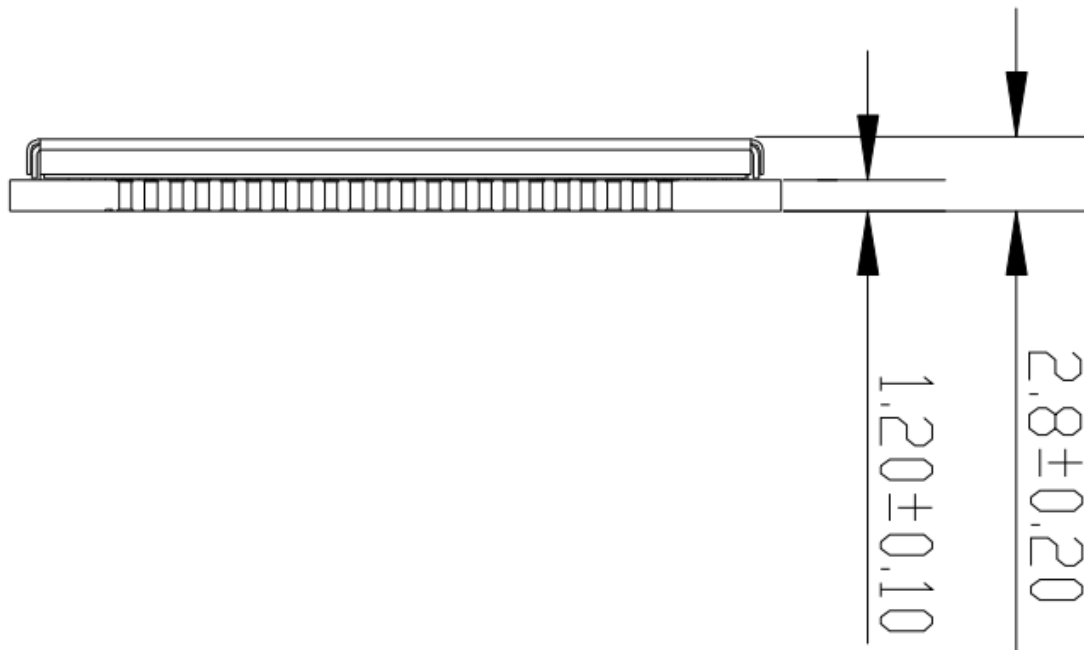

(e)Side view Dimensions(Unit mm)

Figure 2-2 Module Dimensions

## 2.2 Product Function Outline

### 2.2.1 Hardware Diagram

This product mainly includes the following signal group: USB Interface signal、USIM card Interface signal、I2C Interface signal、UART Interface signal、PCM Interface signal、UART Interface signal、SPI interface、Module startup、Module control signal、Power supply and ground.

## 2.2.2 Radio frequency function

RF Function Overview:

- Five-Band FDD-LTE B2/B4/B5/B13/B17
- Dual-Band UMTS/HSDPA/HSPA+ B2/B5
- GPS/BEIDOU/GLONASS

The operating frequency range of the transmitter is shown in table 2-2.

Table 2-3 RF frequency band

Working band	Upstream band (Uplink)	Downlink frequency (Downlink)
WCDMA B5	824 MHz~849 MHz	869 MHz~894 MHz
WCDMA B2	1850 MHz — 1910 MHz	1930 MHz — 1990MHz
FDD_LTE B2	1850 MHz — 1910 MHz	1930 MHz — 1990MHz
FDD_LTE B4	1710 MHz~1755 MHz	2110 MHz~2155 MHz
FDD_LTE B5	824 MHz~849 MHz	869 MHz~894 MHz
FDD_LTE B13	777 MHz~787 MHz	746 MHz~756 MHz
FDD_LTE B17	704 MHz~716 MHz	734 MHz~746 MHz
GPS L1 BAND	--	1574.4 ~1576.44 MHz
GLONASS	--	1598 ~1606 MHz
BEIDOU B1	--	1559.05 ~1563.14 MHz

Table 2-4 Conducted transmission power

Working Band	Max Power	Min Power
WCDMA B5	22.5dBm +/-1dB	<-50dBm
WCDMA B2	23dBm +/-1dB	<-50dBm
FDD_LTE B2	22dBm +/-1dB	<-40dBm
FDD_LTE B4	22dBm +/-1dB	<-40dBm
FDD_LTE B5	22dBm +/-1dB	<-40dBm
FDD_LTE B13	21dBm +/-1dB	<-40dBm
FDD_LTE B17	21dBm +/-1dB	<-40dBm

Table 2-5 Conducted receive sensitivity

Working Band	Receive sensitivity(Typical)	Receive sensitivity(MAX)
WCDMA B2	< -108dBm	3GPP
WCDMA B5	< -109dBm	3GPP

Table 2-6 Reference sensitivity (QPSK)

Channel bandwidth							
E-UTRA Band	1.4 MHz	3 MHz	5 MHz	10 MHz	15 MHz	20 MHz	Duplex Mode
2	-102.2	-99.7	-100	-97.2	-96.2	-95	FDD
4	-102.2	-99.7	-98	-95	-94.2	-93	FDD
5	-102.2	-99.7	-98	-95	--	--	FDD
13	--	--	-100.2	-97.2	--	--	FDD
17	--	--	-97	-94	--	--	FDD

## 3 Interface Description

### 3.1 PIN Definition

#### 3.1.1 Pin I/O parameter definition

The I/O parameter definition of the product is shown in table 3-1.

Table 3-1 I/O parameter definitions

Pin attribute symbol	Description
PI	Power input PIN
PO	Power output PIN
AI	Analog input
AIO	Analog signal input/output PIN
I/O	Digital signal input/output PIN
DI	Digital signal input
DO	Digital signal output
DOH	Digital output with high level
DOL	Digital output with low level
PD	Pull down
PU	Pull up
A0	Analog output

#### 3.1.2 Pin Map

L506 have different version, and the correspond pin definition show as special mark (\* mark or #mark) in the pin map. In the different hardware version the corresponding pin have differential using, detail description show as below chart. All hardware interfaces which connect L506 to customers' application platform are through 87 pins pads (Metal half hole). Figure 3-1 is L506 outline diagram.

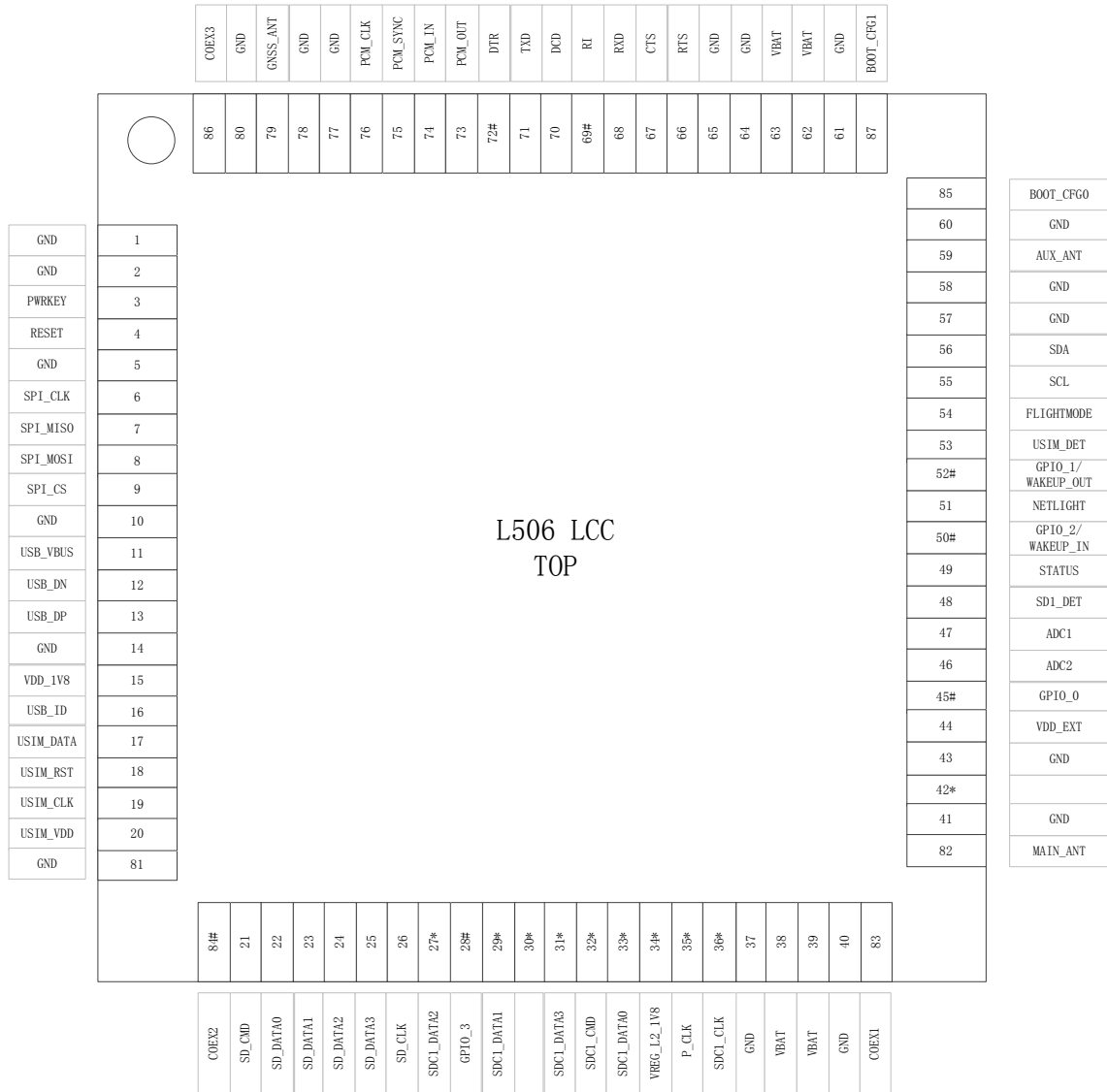

Figure 3-1 Pin Map View (Top View)

**Note: 1.**

*#flag pin in Figure 3-1 stand for multi-function pin. Detail description show as in corresponding function description.*

### 3.1.3 PIN Definition and function description

Table 3-2 Pin definition

Pin No.	Pin description	Pin No.	Pin description
1	GND	2	GND
3	PWRKEY	4	RESET



5	GND	6	SPI_CLK
7	SPI_MISO	8	SPI_MOSI
9	SPI_CS	10	GND
11	USB_VBUS	12	USB_DN
13	USB_DP	14	GND
15	VDD_1V8	16	USB_ID
17	USIM_DATA	18	USIM_RST
19	USIM_CLK	20	USIM_VDD
21	SD_CMD	22	SD_DATA0
23	SD_DATA1	24	SD_DATA2
25	SD_DATA3	26	SD_CLK
27*	SDC1_DATA2	28#	GPIO_3
29*	SDC1_DATA1	30*	
31*	SDC1_DATA3	32*	SDC1_CMD
33*	SDC1_DATA0	34*	VREG_L2_1V8
35*	32K_SLEEP_CLK	36*	SDC1_CLK
37	GND	38	VBAT
39	VBAT	40	GND
41	GND	42*	
43	GND	44	VDD_EXT
45#	GPIO_0	46	ADC2
47	ADC1	48	SD1_DET
49	STATUS	50#	GPIO_2/WAKEUP_IN
51	NETLIGHT	52#	GPIO_1/WAKEUP_OUT
53	USIM_DET	54	FLIGHTMODE
55	SCL	56	SDA
57	GND	58	GND
59	AUX_ANT	60	GND
61	GND	62	VBAT
63	VBAT	64	GND
65	GND	66	RTS
67	CTS	68	RXD

69#	RI	70	DCD
71	TXD	72#	DTR
73	PCM_OUT	74	PCM_IN
75	PCM_SYNC	76	PCM_CLK
77	GND	78	GND
79	GNSS_ANT	80	GND
81	GND	82	MAIN_ANT
83	COEX1	84	COEX2#
85	BOOT_CFG0	86	COEX3
87	BOOT_CFG1		

Table 3-3 Pin Function Description

Power interface				
Pin Name	Pin No.	I/O	Description	Content
VBAT	38, 39, 62, 63	PI	Power supply voltage, VBAT=3.4V~4.2V.	The power supply for system Maximum load current must above 2A.
VDD_1V8	15	PO	Module LDO output power ,1.8V output, Max current 150mA, For I/O, MCP, SLIC, sensors.	If not use keep it open.
VDD_EXT	44	PO	Module LDO output power, 2.85V output, Max current 300mA.	Only use for external SD Card VDD. If not use keep it open.
GND	1, 2, 5, 10, 14, 37, 40, 41, 43, 57, 58, 60, 61, 64, 65, 77, 78, 80, 81		Ground.	
System Control				
Pin Name	Pin No.	I/O	Description	Content
PWRKEY	3	DI	System power on/off input, active low.	
RESET	4	DI	System reset input, active low.	

FLIGHTMODE	54	DI, PU	The input signal, used to control the system into flight mode, H: flight mode; L: normal mode	Pull UP to VDD_1V8 (PIN 15) with 10K resistor
Module status (GPIO)				
Pin Name	Pin No.	I/O	Description	Content
NETLIGHT	51	D0	Identify the system network status.	
STATUS	40	D0	Module status identify: High level power on, low level power off.	

SD interface				
Pin Name	Pin No.	I/O	Description	Content
SD_CMD	21	D0	SDIO command	Advice add the ESD on you SD card Slot. If not use keep it open
SD_DATA0	22	I/O	SDIO data	
SD_DATA1	23	I/O	SDIO data	
SD_DATA2	24	I/O	SDIO data	
SD_DATA3	25	I/O	SDIO data	
SD_CLK	26	D0	SDIO clock	
SD_CARD_DET_N	48	DI, PU	Input pin as SD card detecting.	

			H: SD card is removed L: SD card is inserted	so SD card slot should choose insert detect PIN connect the ground. If not use keep it open
<b>SIM interface</b>				
Pin Name	Pin No.	I/O	Description	Content
USIM_DETECT	53	DI, PU	Input pin as USIM card detect pin. H: USIM is removed L: USIM is inserted	L506 have internal pull up. If not use keep it open.
USIM_DATA	17	I/O	USIM Card data I/O, which has been pulled up with a 10KR resistor to USIM_VDD in module. Do not pull up or pull down in users' application circuit.	All signals of USIM interface should be protected with ESD/EMC.
USIM_RESET	18	DO	USIM Reset	
USIM_CLK	19	DO	USIM Clock	
USIM_VDD	20	PO	USIM Card Power output, output Voltage depends on USIM mode automatically, and one is $3.0V \pm 10\%$ , another is $1.8V \pm 10\%$ . Current is less than 50mA.	
<b>PCM interface</b>				
Pin Name	Pin No.	I/O	Description	Content
PCM_CLK	76	DO	PCM data bit clock.	If not use keep it open.
PCM_SYNC	75	DO	PCM data frame sync signal.	
PCM_IN	74	DI	PCM data input.	
PCM_OUT	73	DO	PCM data output.	
<b>FULL UART/DEBUG PORT</b>				
Pin Name	Pin No.	I/O	Description	Content

RTS	66	DI	DET Request to send.	If not use keep it open.
CTS	67	DO	Clear to Send.	If not use keep it open.
RX	68	DI	Receive Data.	If not use keep it open.
RI	69#	DO	Ring Indicator.	Multiplexed as MDM_DBG_UART_TX. If not use keep it open. Recommend reserved the test point for debug
DCD	70	DO	Carrier detects.	If not use keep it open
TXD	71	DO	Transmit Data.	If not use keep it open.
DTR	72#	DI	DTE get ready.	Multiplexed as MDM_DBG_UART_RX. If not use keep it open. Recommend reserved the test point for debug

#### I2C interface

Pin Name	Pin No.	I/O	Description	Content
I2C_SCL	55	DO	I2C clock output.	L506 internal have pulled up to 1.8V
I2C_SDA	56	I/O	I2C data input/output.	

#### GPIO

Pin Name	Pin No.	I/O	Description	Content
GPIO_2/WAKEUP_IN	50	I/O	Default: GPIO Optional: Input pin as wake/interrupt signal to module from host.	If not use keep it open.
GPIO_1/WAKEUP_OUT	52	DO	Default: GPIO Optional: Output pin as wake/interrupt signal to host from module.	
GPIO_3	28	I/O	GPIO	
GPIO_0	45	DO	Default: GPIO	

			Optional: output control pin.	
RF port				
Pin Name	Pin No.	I/O	Description	Content
MAIN_ANT	82	AIO	Main Antenna	
AUX_ANT	59	AI	diversity antenna	
GNSS_ANT	79	AI	GPS antenna	
Others				
Pin Name	Pin No.	I/O	Description	Content
ADC1	47	AI	Analog conversion digital input interface1	If not use keep it open.
ADC2	46	AI	Analog conversion digital input interface2	
COEX1	83	I/O	RF synchronizing LTE.	If not use keep it open.
COEX3	86	I/O		
COEX2	84#	I/O	Default: RF synchronizing Optional: Pull up to 1.8V (L506A PIN 15 VDD_1V8) with 10K resistor force module in USB download mode	Recommend placing test points for debug.
BOOT_CFG0	85	DI, PD	Pull up to 1.8V (L506A PIN 15 VDD_1V8) with 10K resistor force module in fastboot mode	
BOOT_CFG1	87	DI, PD	Pull up to 1.8V (L506A PIN 15 VDD_1V8) with 10K resistor force module in fastboot mode	

## 3.2 Operating condition

Table 3-4 module recommended operating condition

Parameter	Description	Min.	Typ.	Max.	Unit
VBAT	Main power supply for the module	3.4	3.8	4.2	V

## 3.3 Digital I/O characteristics

Table 3-5 1.8V Digital I/O characteristics

Parameter	Description	Min.	Typ.	Max.	Unit
V <sub>IH</sub>	High level input voltage	0.7*VDD_PX	VDD_PX	VDD_PX+0.3	V
V <sub>IL</sub>	Low level input voltage	-0.3	0	0.2* VDD_PX	V
V <sub>OH</sub>	High level output voltage	VDD_PX-0.45	-	VDD_PX	V
V <sub>OL</sub>	Low level output voltage	0	0	0.45	V
I <sub>OH</sub>	High-level output current (no pull down resistor)	-	2	-	mA
I <sub>OL</sub>	Low-level output current (no pull up resistor)	-	-2	-	mA
I <sub>IH</sub>	Input high leakage current (no pull down resistor)	-	-	1	uA
I <sub>IL</sub>	Input low leakage current (no pull up resistor)	-1	-	-	uA

**\*Note: 1. These parameters are for digital interface pins, such as SP, SDIO, GPIOs (NETLIGHT,**

**FLIGHTMODE, STATUS, USIM\_DET, SD1\_DET), I2C, UART, PCM, COEXn, BOOT\_CFGn.**

**2. L506A TF-card signal (SD\_DATA0~SD\_DATA3, SD\_CLK, SD\_CMD), USIM card signal (USIM\_CLK, USIM\_DATA, USIM\_RST) support dual-voltage (1.8V and 3.0V) mode, and the DC character show in corresponding function block.**

## 3.4 Power Interface

### 3.4.1 Power supply pin description

Table 3-6 DC Power Characteristics

Pin No.	Net Name	Description	DC Characteristic (V)		
			Min.	Typ.	Max.
38, 39, 62, 63	VBAT	Power supply for the module	3.4	3.8	4.2
1, 2, 5, 10, 14, 37, 40, 41, 43, 57, 58, 60, 61, 64, 65, 77, 78, 80, 81	GND	GND	-	-	-
44	VCC_EXT	Power supply for external SD card	-	2.85	-
20	USIM_VDD	Power supply for VDD SIM	-	1.8/3.0	-
15	VDD_1V8	LDO 1.8V output	-	1.8	-
88-99*	GND	Thermal and welding fixed plate	-	-	-

*Note: Pin88~Pin99 (total12pin) is design for the thermal welding fixed plate.*

### 3.4.2 Power supply requirements

There are four VBAT PIN power for the module, VBAT directly power supply for the module baseband and PA, and operating rating is 3.4V~4.2V; In the weak network environment, the antenna will be maximum power emission. The peak current of the module under the 3G mode may reach the peak current of 1.8A. power supply to reach 2A, the average current to reach 0.9A above. maximum peak current can reach 2A, So the max power supply current must more than 2 A. Figure 3-2 sign for instantaneous pulse diagram.

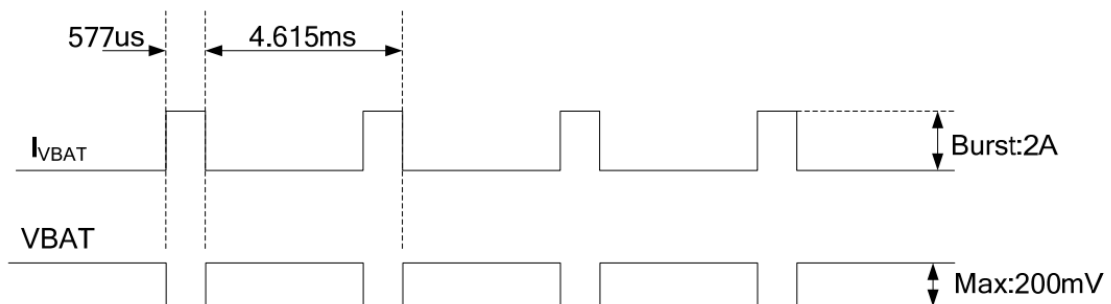

Figure 3-2 instantaneous pulse



Table 3-7 VBAT power supply interface characteristics

Symbol	Description	Min	Typ	Max	Unit
VBAT	Power supply voltage	3.4	3.8	4.2	V
IVBAT(peak)	Power supply peak current	–	2*	–	A
IVBAT(average)	Power supply average current	1	1.5	–	A
IVBAT(power-off)	Power supply current in power off mode	–	–	20	uA
IVBAT(power-save)	Power supply current in power save mode (sleep mode)	–	–	3	mA

### 3.4.3 Power Supply Design Guide

Make sure that the input voltage at the VBAT pin will never drop below 3.4V even during a transmit burst when the current consumption rises up to more than 2A. If the power voltage drops below 3.4V, the RF performance of module may be affected. Using large tantalum capacitors (above 300uF) will be the best way to reduce the voltage drops. If the power current cannot support up to 2A, users must introduce larger capacitor (typical 1000uF) to storage electric power. For the consideration of RF performance and system stability, some multi-layer ceramic chip (MLCC) capacitors (0.1/1uF) need to be used for EMC because of their low ESR in high frequencies. Note that capacitors should be put beside VBAT pins as close as possible. Also User should keep VBAT net wider than 2 mm to minimize PCB trace impedance on circuit board. The following figure is the recommended circuit.

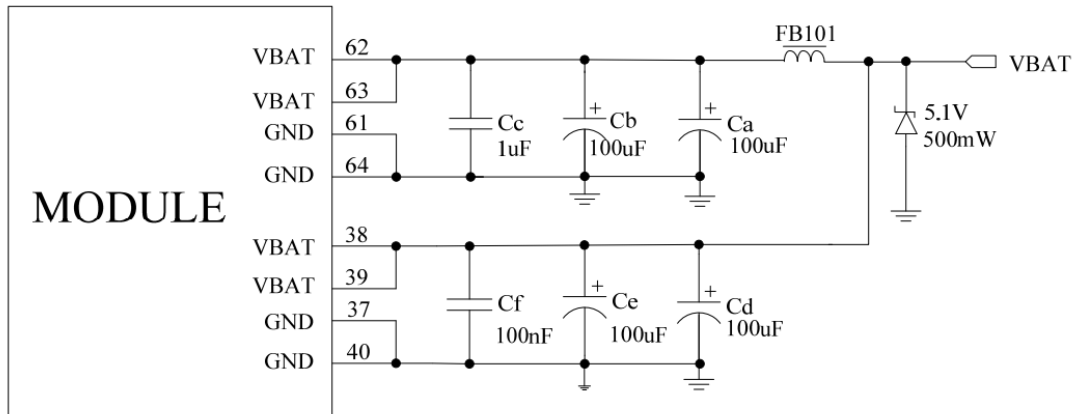

Figure 3-3 VBAT input application circuit

*Note: The Cd, Ce, Cb, Cc and Cf are recommended being mounted for L506, but the Ca, Cb, Ce, Cc and Cf for tune.*

In addition, in order to get a stable power source, it is suggested to use a Zener diode of which reverse Zener voltage is 5.1V and dissipation power is more than 500mW.

Table 3-8: Recommended Zener diode models

NO.	Manufacturer	Part Number	Power	Package
1	On semi	MMSZ5231BT1G	500mW	SOD123
2	Prisemi	PZ3D4V2H	500mW	SOD123
3	Vishay	MMSZ4689-V	500mW	SOD123
4	Crownpo	CDZ55C5V1SM	500mW	0805

### 3.4.4 Recommended Power supply circuit

If the voltage difference is not big, We recommend DCDC or LDO is used for the power supply of the module, make sure that the peak current of power components can rise up to more than 2A. The following figure is the reference design of +5V input linear regulator power supply. The designed output for the power supply is 3.8V.

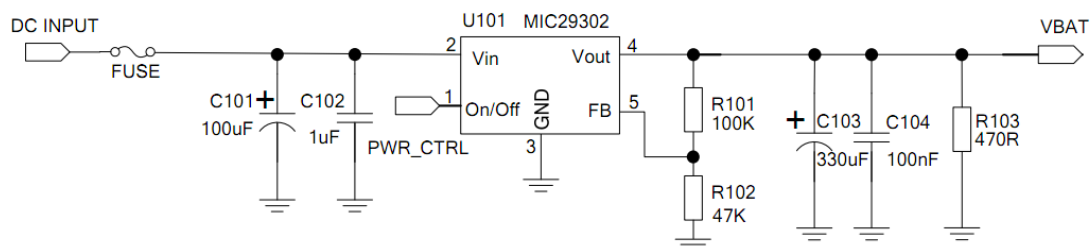

Figure 3-4 Reference circuit of the LDO power supply

If there is a big difference between the input voltage and the desired output (VBAT) or better efficiency is more important, a switching converter power supply will be preferable. The following figure is the reference circuit.

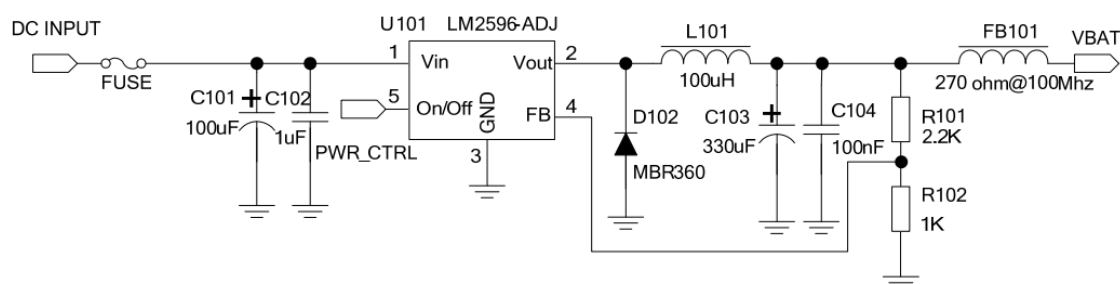

Figure 3-5 Reference circuit of the DCDC power supply

Note: DCDC may deprave RF performance because of ripple current intrinsically.

### 3.4.5 Power Supply Layout guide

The layout of the power supply section and the related components is of vital importance in the power module design. If processes this part layout is not good, will lead to various effects, such as bad EMC, effective the emission spectrum and receiving sensitivity, etc. So the power supply part design is very important, when you design this part you should notes below contents: 1. DC DC switch power should place away from the antenna and other sensitivity circuit; 2. Consider the voltage drop and the module current requirement, the layout line should better above 100mil. If conditions allow should add a power shape plane.

## 3.5 USIM interface

### 3.5.1 Pin definition

The L506 integrated a ISO 7816-2 standard USIM port, and the module can automatic identify the voltage demo according the USIM to allow the mobile equipment to attach to the network. Both 1.8V and 3.0V SIM Cards are supported.

Table 3-9 USIM Electronic characteristic in 1.8V mode (USIM\_VDD =1.8V)

Symbol	Parameter	Min.	Typ.	Max.	Unit
USIM_VDD	LDO power output	1.75	1.8	1.95	V
V <sub>IH</sub>	High-level input voltage	0.65 USI M_VDD	–	USIM_V DD +0.3	V
V <sub>IL</sub>	Low-level input voltage	-0.3	0	0.35 USI M_VDD	V

V <sub>OH</sub>	High-level output voltage	USIM_V DD -0.45	--	USIM_V DD	V
V <sub>OL</sub>	Low-level output voltage	0	0	0.45	V

Table 3-10: USIM Electronic characteristic 3.0V mode (USIM\_VDD =3.0V)

Symbol	Parameter	Min.	Typ.	Max.	Unit
USIM_VDD	LDO power output	2.75	3.0	3.05	V
V <sub>IH</sub>	High-level input voltage	0.65*USI M_VDD	-	USIM_V DD +0.3	V
V <sub>IL</sub>	Low-level input voltage	-0.3	0	0.25 USI M_VDD	V
V <sub>OH</sub>	High-level output voltage	USIM_V DD -0.45	-	USIM_V DD	V
V <sub>OL</sub>	Low-level output voltage	0	0	0.45	V

### 3.5.2 Design Guide

USIM electronic characteristics as the table 3-8,3-9 show.

In order to meet the 3 GPP TS 51.010 1 protocol and EMC certification requirements. Suggest USIM slot near the location of the module USIM card interface, to avoid running for too long, lead to serious deformation of waveform and effect signal integrity, USIM\_CLK and USIM\_DATA signal lines suggest ground protect. Between the USIM VCC & GND add a 1uF and a 33 pF capacitor in parallel, Between the USIM\_CLK& GND, USIM\_RST& GND, USIM DATA& GND add a 33 pF capacitor in parallel, for filter the RF signal interference.

### 3.5.3 USIM interface reference circuit

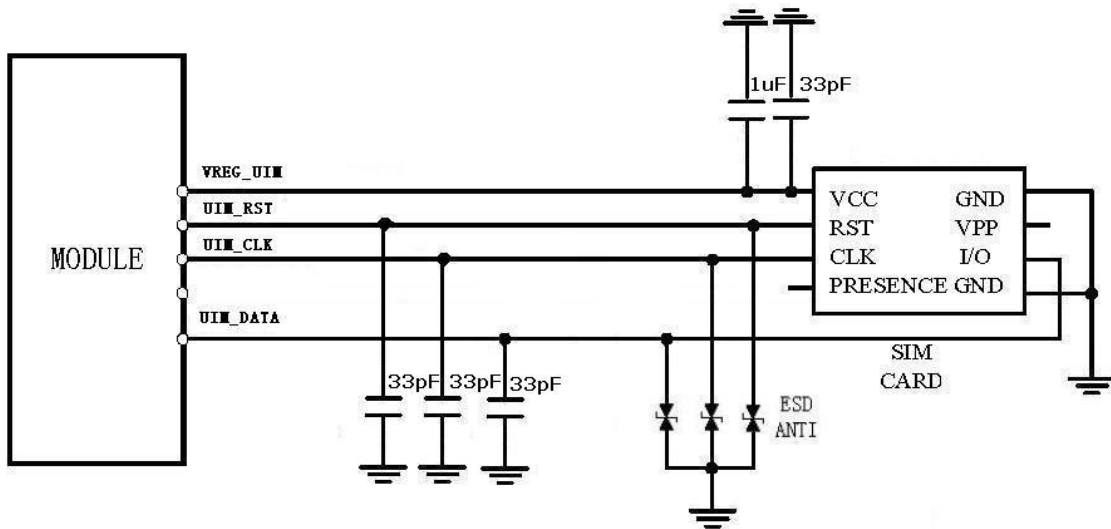

Figure 3-6 USIM Reference circuit

Note:USIM\_DATA have added the pull-up resistance in the module design.

### 3.6 PCM interface

#### 3.6.1 PCM interface definition

L506 provides hardware PCM interface for external codec. L506 PCM interface can be used in short sync master mode only, and only supports 16 bits linear format:

Table 3-11 PCM interface definition

Pin No.	Signal name	I/O Type	DC Characteristics (V)		
			Min.	Typ.	Max.
75	PCM_SYNC	PCM synchronizing signal	-0.3	1.8	1.9
74	PCM_DIN	PCM data input	-0.3	1.8	1.9
73	PCM_DOUT	PCM Data output	-0.3	1.8	1.9
76	PCM_CLK	PCM Data clock	-0.3	1.8	1.9

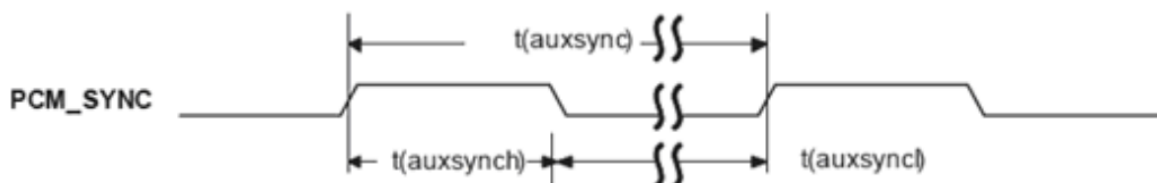

Figure 3-7 PCM\_SYNC timing

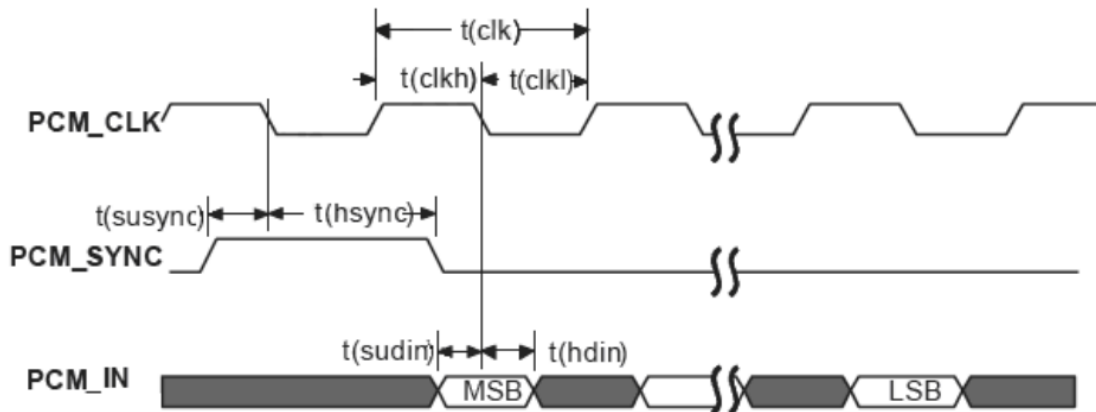

Figure 3-8 Codec to L506 module timing

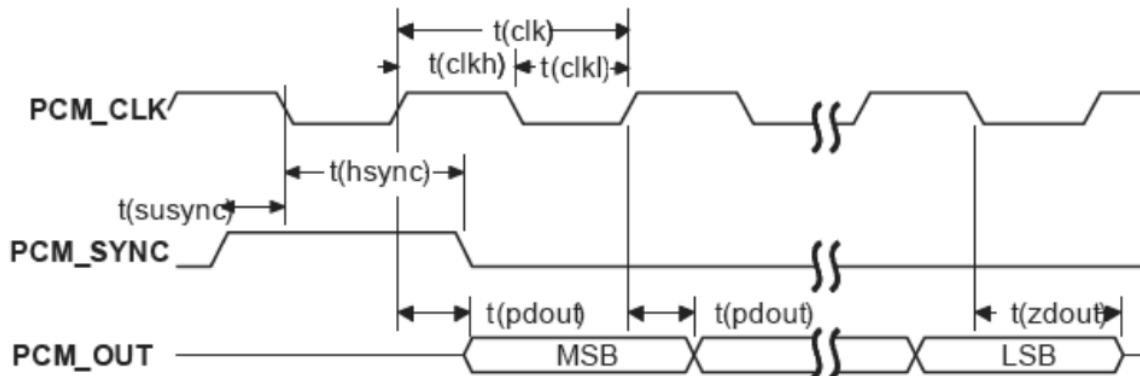

Figure 3-9 L506 to codec module timing

Table 3-12 PCM interface Timing

Parameter	Descriptions	DC characters			
		Min.	Typ.	Max.	Unit
T(sync)	PCM_SYNC cycle	-	125	-	us
T(synch)	PCM_SYNC high level hold time	-	488	-	ns
T(sync1)	PCM_SYNC low level hold time	-	124.5	-	us
T(clk)	PCM_CLK cycle	-	488	-	ns
T(clkh)	PCM_CLK high level hold time	-	244	-	ns

T(clkl)	PCM_CLK low level hold time	–	244	–	ns
T(susync)	PCM_SYNC establish time	–	122	–	ns
T(hsync)	PCM_SYNC hold time	–	366	–	ns
T(sudin)	PCM_IN establish time	60	–	–	ns
T(hdin)	PCM_IN hold time	60	–	–	ns
T(pdout)	From PCM_CLK rising edge to PCM_OUT valid time	–	–	60	ns
T(zdout)	From PCM_CLK falling edge to PCM_OUT high impedance delay time	–	–	60	ns

### 3.6.2 PCM interface application

L506 only support the host mode, PCM\_SYNC, PCM\_CLK is the output pin, PCM\_SYNC as the synchronizing output 8kHz sync signal. PCM Data support 8bit or 16bit data.

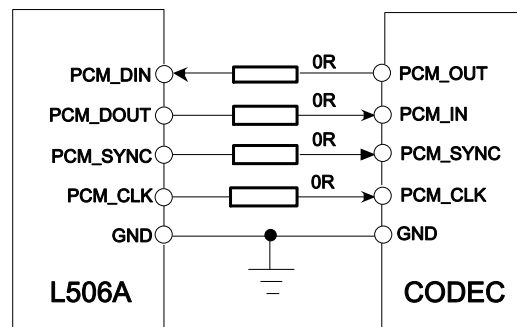

Figure 3-10 PCM application circuit (L506 in host mode)

**Note:1.** L506 PCM port DC character is base on 1.8 voltage, please pay attention the voltage matching.

**2.** If your design need this function, you should add the crystal for PCM clock. About the crystal type please contact our market.

**3.** L506 default design base on NAU8814 as the codec chip, the detail design please refer to 《L506 reference design》 .

## 3.7 USB2.0 interface

### 3.7.1 USB interface pin definition

L506 integrated a USB 2.0 port and low speed mode full speed mode and high speed mode

transmission speed between the AP and the host. Below table is the module USB pin definition

Table 3-13 USB interface pin definition

Pin No.	Signal name	I/O type	DC characteristic (V)		
			Min.	Typ.	Max.
12	USB_DM	USB2.0 data D-	-	-	-
13	USB_DP	USB2.0 data D+	-	-	-

### 3.7.2 USB Interface application

USB bus is mainly used for data transmission, software upgrading, module testing. Work in the high-speed mode of the USB line, if you need ESD design, ESD protection device must meet the junction capacitance value <math><5\text{pf}</math>, otherwise the larger junction capacitance will cause waveform distortion, the impact of bus communication. Differential impedance of differential data line in  $90\text{ohm} + 10\%$ . In your application must add a  $47\text{Kohm}$  resistor between USB\_VBUS to ground.

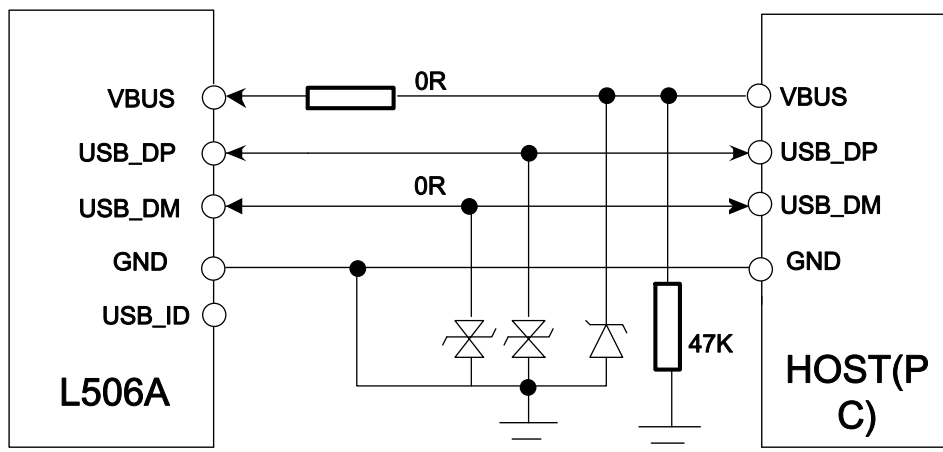

Figure 3-11 USB application

## 3.8 UART Interface

### 3.8.1 Pin description

L506 module provides a flexible 7-wire UART (universal asynchronous serial transmission) interface. UART as a full asynchronous communication interface, Support the standard modem handshake signal control, Comply with the RS - 232 interface protocols. And also support four wire serial bus interface or the 2-wire serial bus interface mode, and the module can be through the UART



interface for serial communication with the outside (DET) and the AT command input, etc. L506 module is a DCE (Data Communication Equipment) and client PC is a DTE (Data Terminal Equipment). AT commands are entered and serial communication is performed through UART interface. The pin signal is defined as shown in below table.

Table 3-14 UART pin definition

Pin No.	Pin	I/O type	Descriptions
71	UART_TX	DO	UART data transmission
68	UART_RX	DI	UART data receive
69	UART_RI	DO	Ring Indicator.
66	UART_RTS	DO	UART DET request to send
72	UART_DTR	DI	DTE get ready.
67	UART_CTS	DI	UART Clear to Send.
70	UART_DCD	DO	UART Carrier detects.

**Note:** *UART\_RI, UART\_DTR can be used as two line UART interface for system debugging, See table 3-3 Pin functional description.*

### 3.8.2 UART interface application

UART\_RI, UART\_DTR default status is the system log port, so we recommend that users keep reserved the interface and test points in design. The L506 UART is 1.8V interface. A level shifter should be used if user's application is equipped with a 3.3V UART interface. The level shifter TXB0108RGYR provided by Texas Instruments is recommended. The reference design of the TXB0108RGYR is in the following figures. About the application as below:

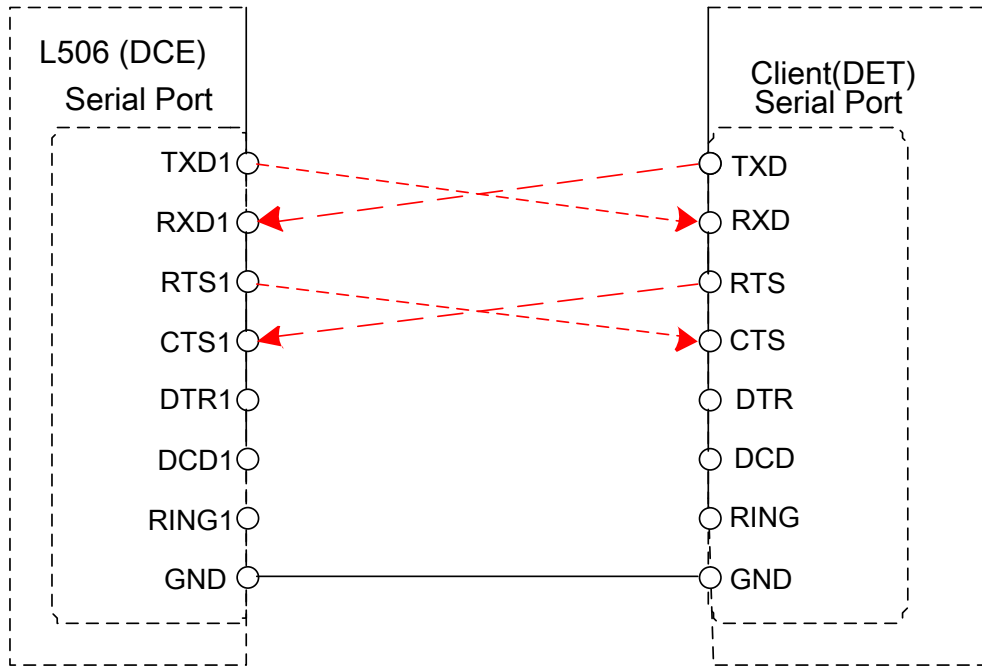

Figure 3-12 UART 4 Line connection mode

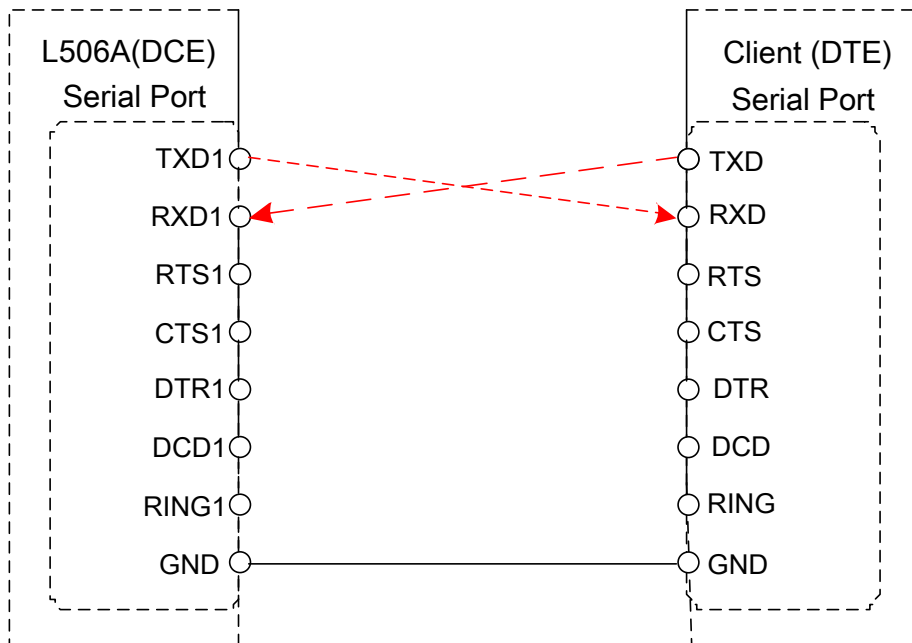

Figure 3-13 UART 2 Line connection mode

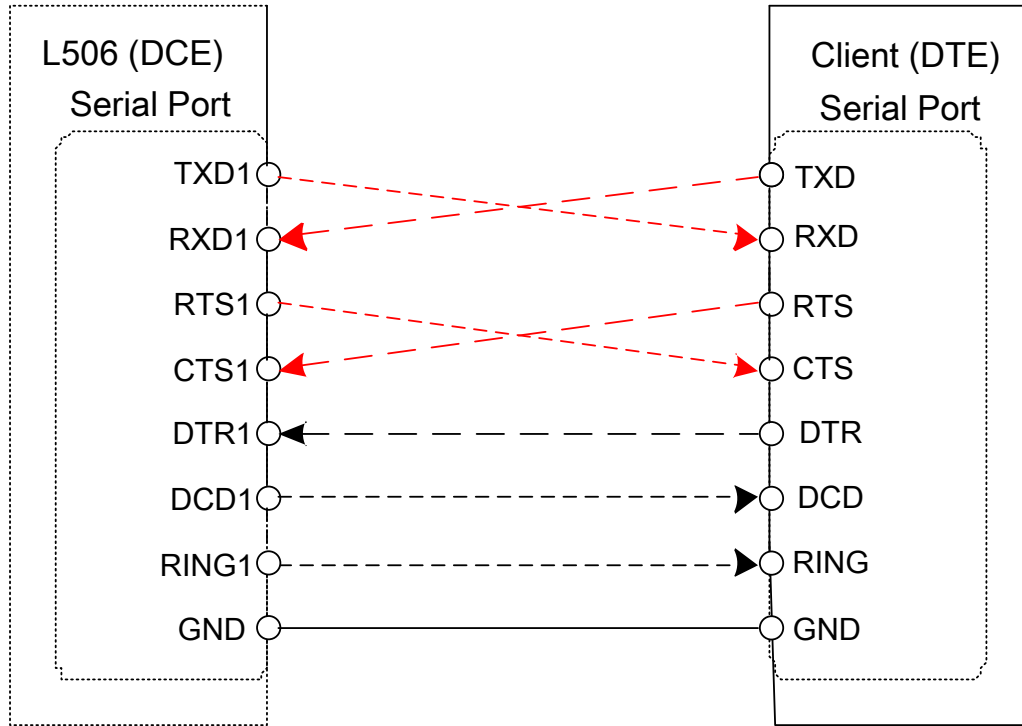

Figure 3-14 UART Full mode

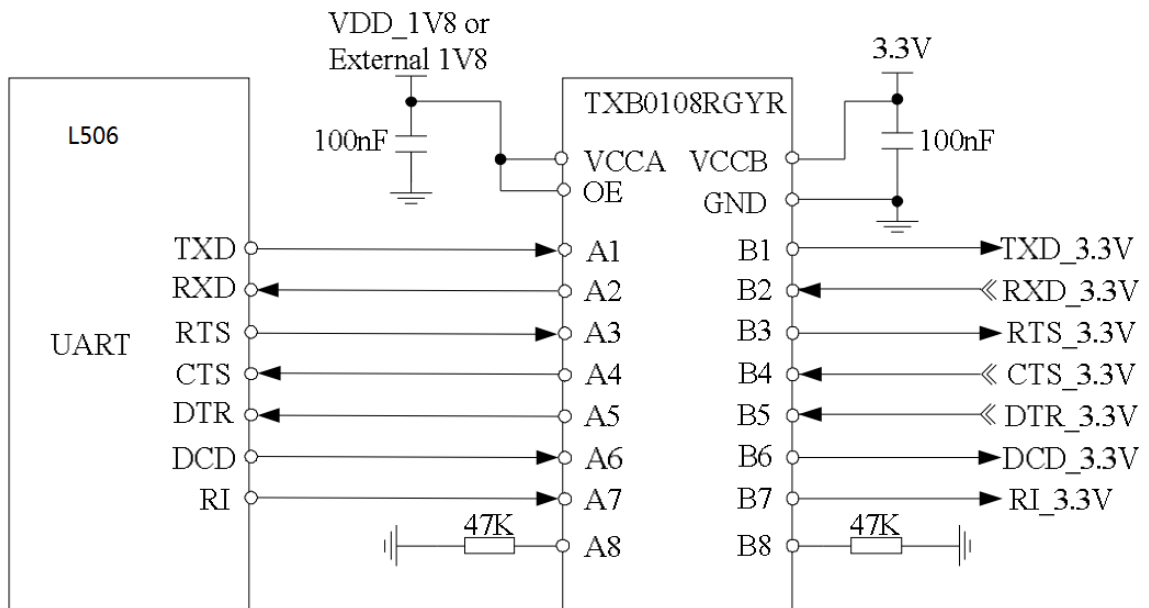

Figure 3-16 Voltage transfer Reference Circuit

## 3.9 Power on/off and reset interface

### 3.9.1 Pin definition

L506 can be powered on by pulling PWRKEY pin down to ground. This pin is already internal pulled up to 1.8V in module, so external pull-up resistor is not necessary. Placing a 100nF capacitor and an ESD protection diode close to the PWRKEY pin is strongly recommended. Please refer to the following figure for recommended reference circuit L506 also have a RESET pin to reset module. This function is used as an emergency reset only when AT command “AT+CPOF” and the PWRKEY pin has no effect. User can pull RESET pin to ground, then module will reset. This pin is already pulled up with a 40KΩ resistor to 1.8V in module, so external pull-up resistor is not necessary. Placing a 100nF capacitor and an ESD protection diode close to the RESET pin is strongly recommended. Please refer to the following figure for recommended reference circuit, you can pull-down this pin to ground and hold about 200 MS and then release will force the module enter reset state

Table 3-15 power on/off and reset key define

Pin No.	Net name	I/O Typ.	descriptions
3	PWRKEY	DI	L506A power on/off pin (internal pull-up to 1.8V)
4	RESET	DI	L506A RESET pin (internal pull-up to 1.8V)

### 3.9.2 Power on sequence

Table 3-16 power on timing chart.

Ton	Power on low level pulse	100	500	--	ms
Ton(status)	Power on time (According to the STATUS pin judgment)	15	--	25	s
Ton(uart)	Power on time (according the UART pin judgement)	10	--	20	s
V <sub>IH</sub>	Input high level voltage of PWRKEY pin	1.17	1.8	2.1	V
V <sub>IL</sub>	Input low level voltage of PWRKEY pin	-0.3	0	0.3	V

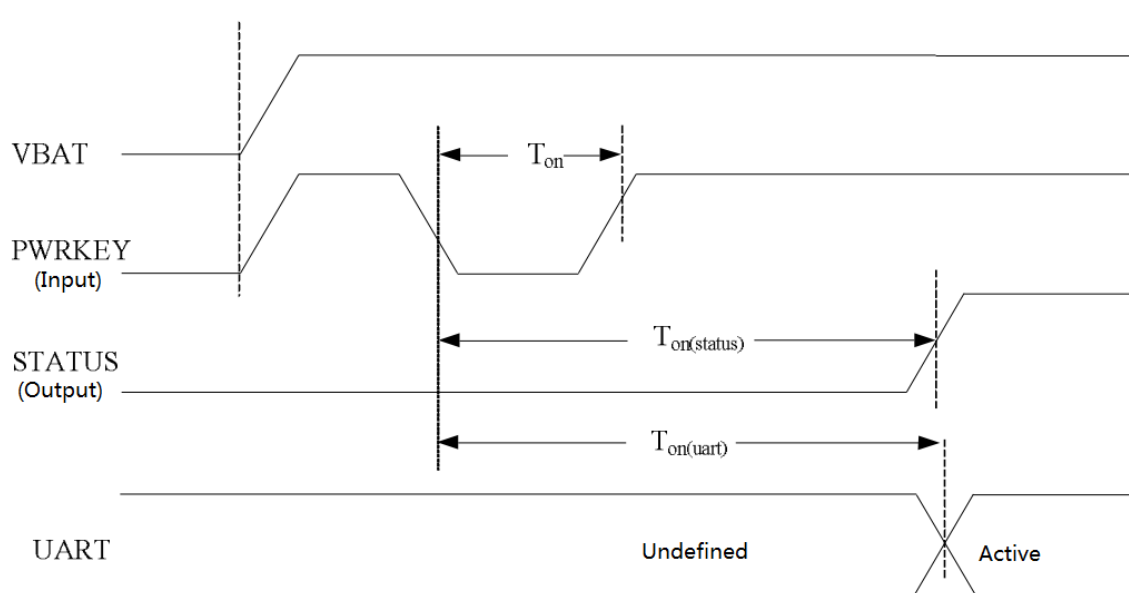

Figures 3-17 Power on Timing sequence

**Note:** the STATUS pin can be used to identify whether has been power on, when the module has access to electricity and initialization is completed, the STATUS output high level, or has maintained low level.

### 3.9.3 Power off sequence

The following methods can be used to power down. These procedures will make module disconnect from the network and allow the software to enter a safe state, and then save data before completely powering the module off.

- Method 1: Power off L506A by pulling the PWRKEY pin down
- Method 2: Power off L506A by AT command “AT+CPOF”
- Method 3: over-voltage or under-voltage automatic power down.
- Method 4: over-temperature or under-temperature automatic power down.

Note: 1. About the AT command “AT+CPOF” detail please refer document [1].

**2. Over-voltage or under-voltage may cause automatic power down.**

**3. Over-temperature or under-temperature may cause automatic power down.**

Table 3-17 Power off timing chart.

$T_{off}$	The time of active low level pulse on PWRKEY pin to power off module	2.5	--	--	s
$T_{off(status)}$	The time from power-off issue to STATUS pin output low level (indicating power off)	6	--	--	s
$T_{off(uart)}$	The time from power-off issue to UART port off	6	--	--	s
$T_{off-on}$	The buffer time from power-off issue to power-on issue	0	--	--	V
$V_{IH}$	Input high level voltage of PWRKEY pin	1.17	1.8	2.1	V
$V_{IL}$	Input low level voltage of PWRKEY	-0.3	0	0.3	V



User can power off the L506 by pulling PWRKEY down to ground for a specific time. The

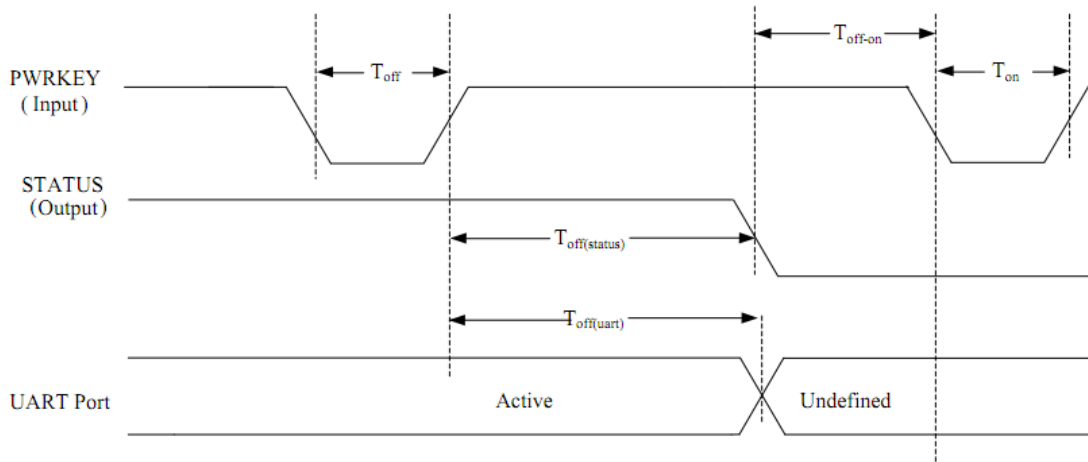

Figures 3-18 Power off Timing sequence

*Note: the STATUS pin can be used to identify whether has been power on, when the module has access to electricity and initialization is completed, the STATUS output high level, or has maintained low level.*

### 3.9.4 Reset sequence

L506 can lower module RESET pin to restart the module.

Table 3-18 Reset pin electrical properties

Symbol	Net name	Min.	Typ.	Max.	Unit
Treset	Reset pin low level hold time	50	100	500	ms
V <sub>IH</sub>	Reset pin input high level	1.17	1.8	2.1	V
V <sub>IL</sub>	Reset pin input low level	-0.3	0	0.3	V

*Note: it is recommended that only in an emergency, such as module without response, use the RESET pin. In addition, under the module power off status the RESET pin is invalid.*

### 3.9.5 Power on/off and reset interface application

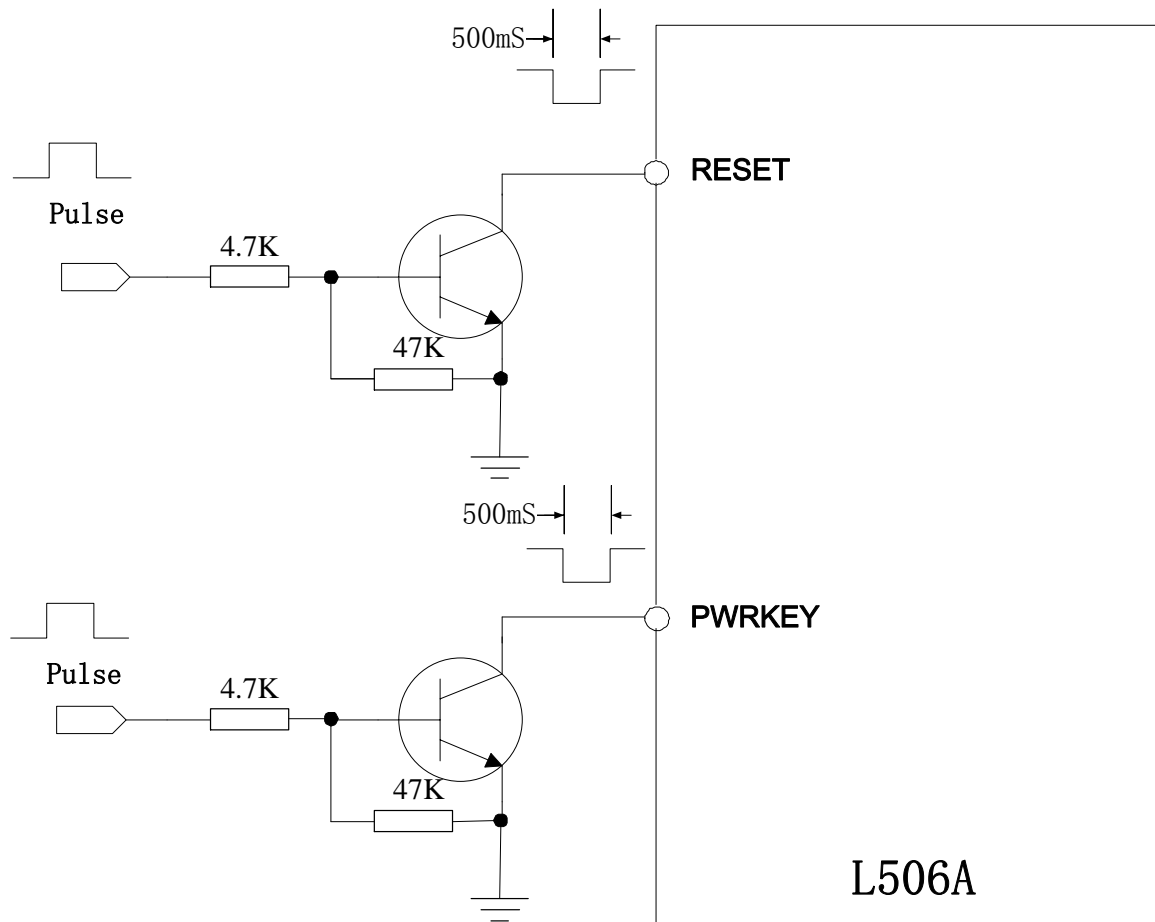

Figure 3-19: Reference power on/off reset circuit

Another way to control the PWRKEY pin is directly using a push button switch. Need to set a button near the TVS to ESD protection. The image below for reference circuit:

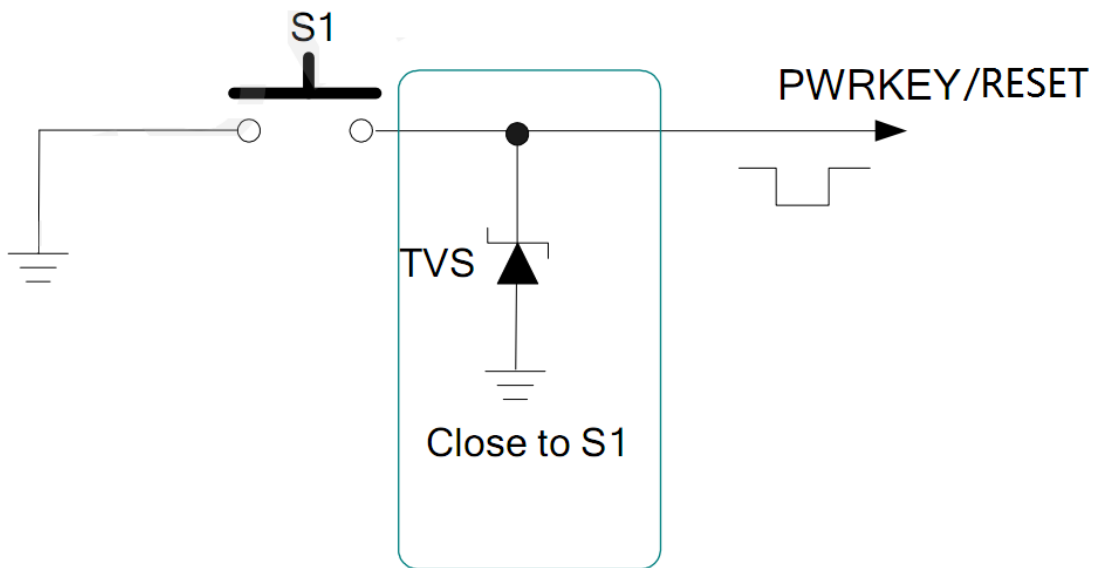

Figure 3-20: power on/off and reset recommended circuit (physical buttons)

## 3.10 Interactive interface

### 3.10.1 Pin definition

Table 3-19 list the interface is mainly with the application processor interactive interface, including query, wake up four types, status indication, flight mode interface.

Table 3-19 Interactive interface

Pin No.	Signal	I/O type	Descriptions
50	GPIO_2/WAKEUP_IN	DI	Default: GPIO Optional: Input pin as wake up interrupt signal to module from host.
52	GPIO_1/WAKEUP_OUT		Default: GPIO Optional: Output pin as the module wake up the AP
49	STATUS	DO	AP inquire the module status
54	FLGHTMODE	DI	Pull up to 1.8V made the system enter in flight mode, at this mode will tune off all the wireless function
45	GPIO_0	DO	General GPIO module output (used for keyboard backlighting, etc.)
28	GPIO_3	I/O	GPIO



### 3.10.2 interactive interface application

L506 provides three shook hands with application processor communication signals. Application processor can query whether the module boot normal work through STATUS. Through the WAKEUP\_OUT query module is in sleep mode, and sleep in the module, through WAKEUP\_IN wake module. Similarly, when application processor in the sleep state, the L506 modules can through WAKEUP\_OUT wake application processor.

- STATUS: Module sleep instructions, high level indicator to sleep, low level instructions for the awakened state;
- WAKEUP\_IN: The host can lower the signal awakens the module, If, low level has maintained, module can't sleep.
- WAKEUP\_OUT: when L506A need to communicate with the AP, module can be set this pin for low level to awaken application processor.
- FLGHTMODE: Through the external output high level module into flight mode;

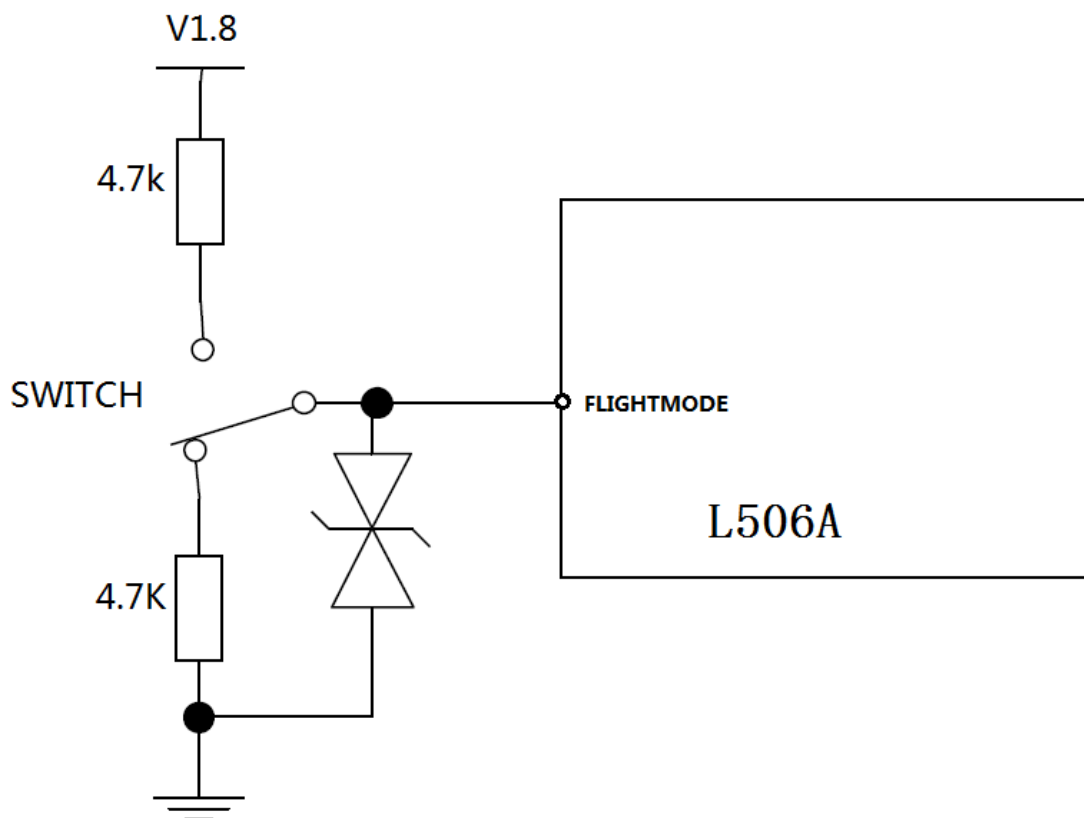

Figure 3-21: Flight mode recommended circuit (physical buttons)

## 3.11 Net Light interface

### 3.11.1 Pin define

Table 3-20 LED pin definitions

Pin No.	Net name	I/O type	description
51	NETLIGHT	D0	Module net state identify control LED port

### 3.11.2 Net light application

The L506 module has 1 pins for controlling the LED display, which can be used as an indicator of network connection status. Different network states are represented by the mode of the flashing light. This pin is an GPIO, with An external NPN Transistor, External connect VBAT can directly drive LED. Drive current capacity varies according to external NPN model, recommend use DTC143ZEBTL, Drive current biggest can reach 100 mA, below is the reference circuit.

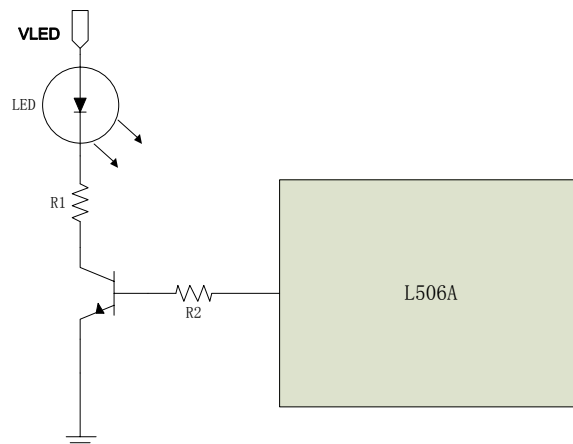

Figure 3-22 Status indicator reference circuit

Note: R1, R2 value according to the voltage VLED and LED working current.

Table 3-21 NETLIGHT status

Net Status	Module working status
Always on	Searching Network/Call Connect
200ms ON, 200ms OFF	Data Transmit
800ms ON, 800ms OFF	Registered network
OFF	Power off / Sleep

**Note:** NETLIGHT output low level as “ON”, and high level as “OFF”.

## 3.12 SD card interface

### 3.12.1 Pin descriptions

L506 provides a 4-bit SD/MMC interface with clock rate up to 52MHz. The operation voltage of MMC/SD interface is 2.85V with SD/MMC memory cards up to 128G(FAT4), which is compatible with SDIO Card Specification (version 3.0), Secure Digital (Physical Layer Specification, version 3.0) and Multimedia Card Host Specification MMC (version 4.4)

Table 3-22 SD characteristics

Symbol	Parameter	Min.	Typ.	Max.	Unit
VDD_EXT**	LDO output	–	2.85	–	V
V <sub>IH</sub>	High-level input voltage	0.625*VDD_EXT	–	VDD_EXT+0.3	V
V <sub>IL</sub>	Low-level input voltage	-0.3	0	0.25*VDD_EXT	V
V <sub>OH</sub>	High-level output voltage	2.75*VDD_EXT	2.85	VDD_EXT	V
V <sub>OL</sub>	Low-level output voltage	0	0	0.125*VDD_EXT	V

SD card I/O load capacity for linear output displacement, concrete can be calculated according to the following chart;

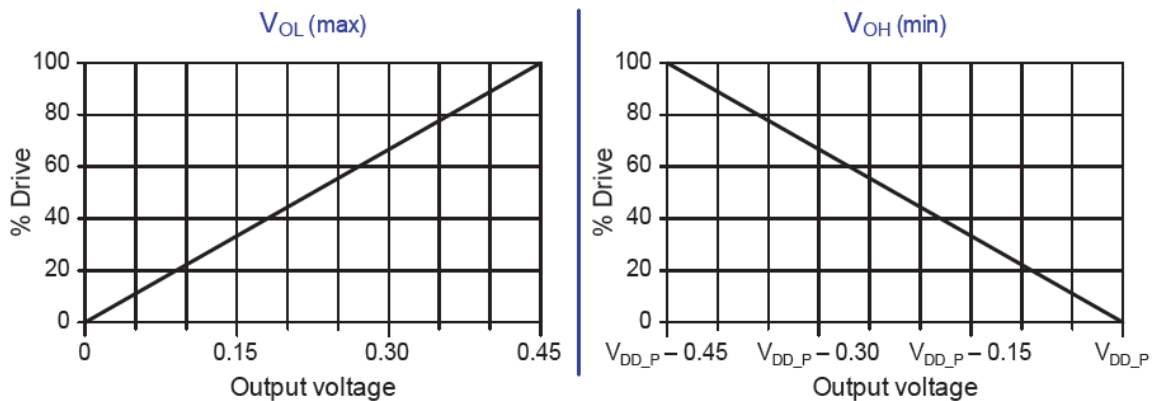

Figure 3-23 VOL/VOH IV curve

### 3.12.2 SD card interface design guideline

L506 VDD\_EXT for external SD card interface of power supply, in the card slot position should add the ESD protection circuit; If you need to support SD hot plug design need to add SD\_DET signals. Due to the default hot plug pin of L506 check for low level to identify the card insert status, so you need to choose the detect PIN connected to the ground when SD card is inserted into the SD slot, below is the reference circuit.

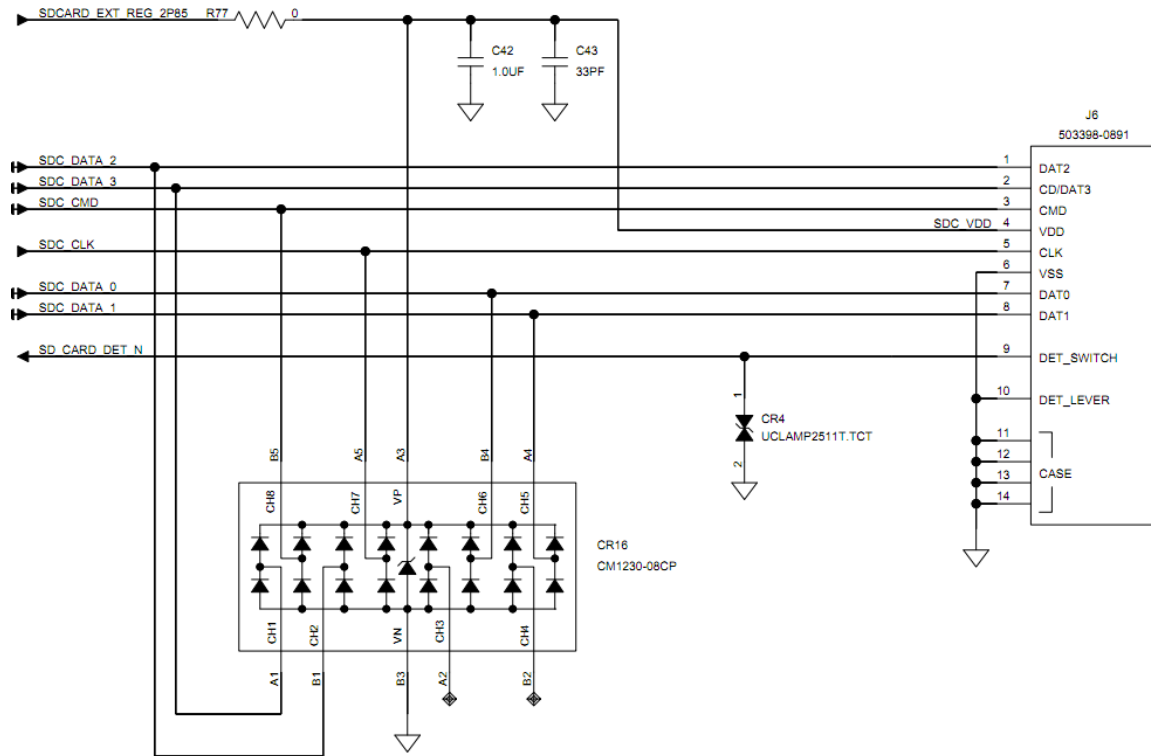

Figure 3-24 SD card recommended circuit

### 3.12.3 SD card signal PCB line rules

Due to the SD signal is the high-speed digital interface, so its layout rules should be in accordance with the high speed digital rules.

1. Protect other sensitive signals/circuits from SDC corruption.
2. Protect SDC signals from noisy signals (clocks, SMPS, etc.).
3. 50  $\Omega$  nominal,  $\pm 10\%$  trace impedance.
4. CLK to DATA/CMD length matching  $< 1$  mm.
5. Total routing length  $< 50$  mm recommended.
6. Spacing to all other signals = 2x line width. 6 Bus capacitance  $< 15$  pF.

## 3.13 System boot configuration and download

### 3.13.1 Pin definition

L506 can configure BOOT\_CONFIG (Boot Configuration) pin to Configuration module power-on mode and the forced entry USB download mode.

## BOOT CONFIGURATION TABLE

BOOT_CONFIG[3:1]	BOOT OPTIONS
0b000	NAND → USB
0b001	Only USB

Table 3-23 Boot configuration and force USB download

Pin No.	Net name	Function description	note
85	BOOT_CFG0	Pull up this pin change boot configuration register value	
87	BOOT_CFG1	Pull up this pin change boot configuration register value	
84	COEX2 (System on)	FOCE_USB_BOOT (before system on)	Multiplex pin

### 3.13.2 Boot configuration and force USB interface application

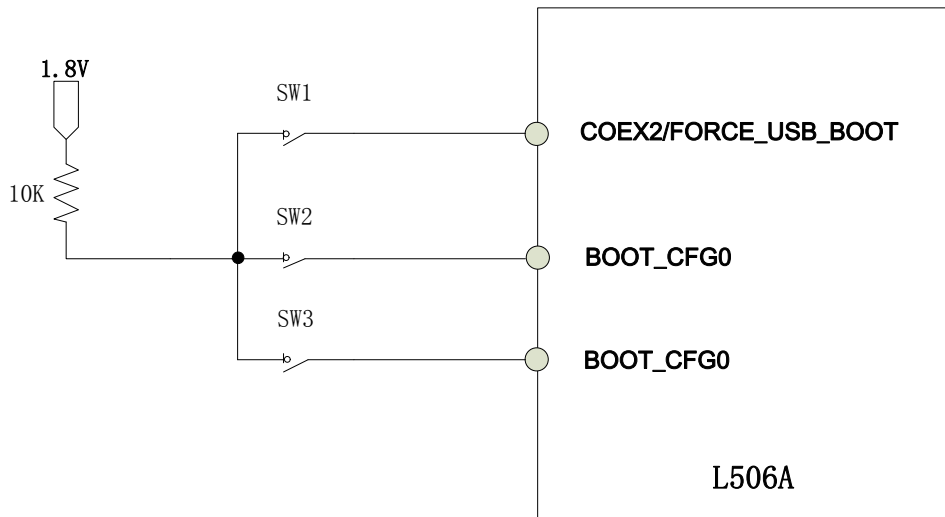

Figure 3-25 boot configuration and force USB download recommended circuit

## 3.14 Analog and Digital conversion (ADC) interface

### L506 Hardware Design

L506 integrated two analog-to-digital conversion interface, specific parameters are as follows:

Table 3-25 ADC1, ADC2 characters

characters	Min.	Typ.	Max.	Unit
ADC resolution	--	15	--	Bits
Transfer time	--	442	--	ms

Copyright © Shanghai Mobiletek Communication Ltd

50

Input voltage range	0.3	--	VBAT	V
Input resistance	1	--	--	MΩ

**Note:** 1. use "AT + CADC" and "AT + CADC2" can read ADC1 and ADC2 voltage on the pin.  
More information please refer to the document [1].

2. The need for special software version to support access to the ADC.

## 3.15 I2C interface

### 3.15.1 I2C pin definition

I2C is used to communicate with peripheral equipment and can be operated as either a transmitter or receiver, depending on the device function. Both SDA and SCL are bidirectional lines connected with I2C interface. Its operation voltage is 1.8V. High speed mode transmission rate can reach 400 KBPS, Because L506 have internal pulled up to the I2C interface, so in your design needn't pull up. Figure 3-15 is the reference design:

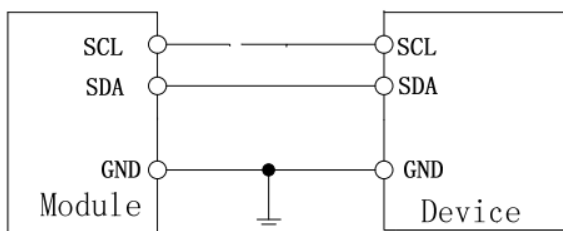

Figure 3-28 I2C reference design

Note: 1. L506 I2C only support host mode.

2. Only special software version support inquire the I2C.

## 3.16 Antenna interface

### 3.16.1 RF signal PCB layout guide

L506 provides RF antenna interface. Customer's antenna should be located in the host board and connected to module's antenna pad through micro-strip line or other types of RF trace and the trace impedance must be controlled in 50Ω. we recommends that the total insertion loss between the antenna pad and antenna should meet the following requirements:

- WCDMA 1900<0.9dB
- WCDMA 850<0.5 dB
- LTE (F<1GHz) <0.5dB
- LTE (1GHz<F<2GHz) <0.9dB
- LTE (2GHz<F) <1.2dB

To facilitate the antenna tuning and certification test, a RF connector and an antenna matching circuit should be added. The following figure is the recommended circuit.

The antenna feed point is defined as shown in below table:

Table 3-26 antenna pin definition

Pin No.	Signal	I/O Typ.	Description
82	MAIN_ANT	AI/AO	Module main antenna
59	AUX_ANT	AI	LTE diversity antenna feed point
79	GNSS_ANT	AI	GNSS antenna feeder connector

### 3.16.2 applications

For convenience of antenna tuning and certification test, should increase RF connectors and the antenna matching circuit, below is a recommended circuit:

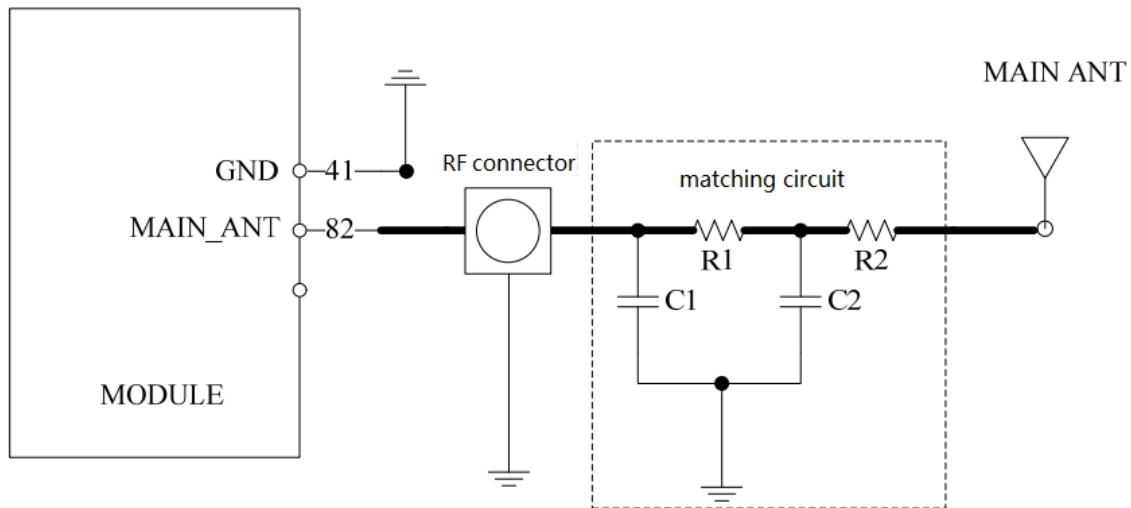
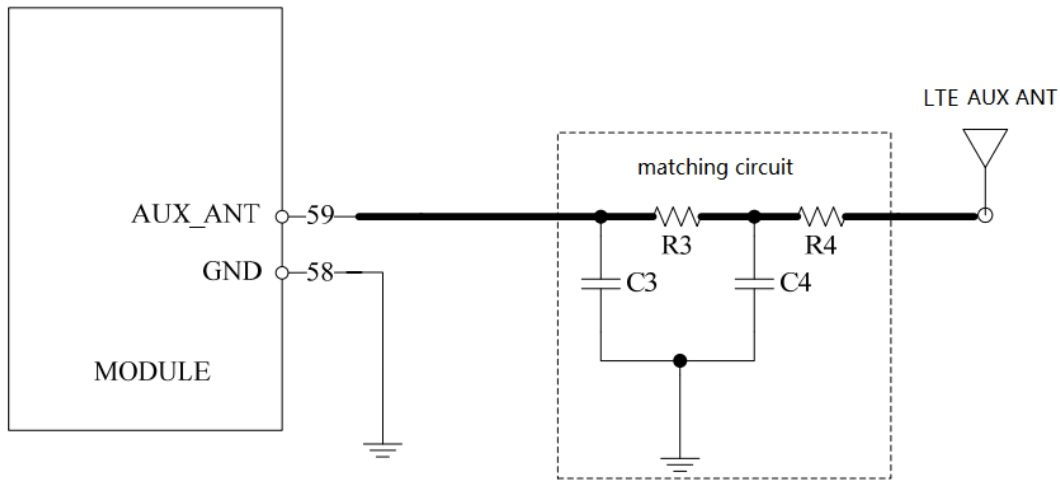

**Figure 3-29** Main antenna matching circuit diagram (MAIN\_ANT)

In this figure, the components R1, C1, C2 and R2 is used for antenna matching, the value of components can only be got after the antenna tuning, usually, they are provided by antenna vendor. By default, the R1, R2 are 0 Ohm resistors, and the C1, C2 are reserved for tuning.

The RF test connector in the figure is used for the conducted RF performance test, and should be placed as close as to the module's antenna pin. The traces impedance between components must be

controlled in 50ohm.



**Figure 3-30** LTE Diversity antenna matching circuit diagram (AUX\_ANT)

Note: LTE diversity antenna recommend leaving. Because there are many high frequencies of TDD LTE design, such as band38 band40 and Band41. Due to the high insertion loss RF line, if there is no diversity antenna, receiving sensitivity of the spectrum in the certification will be a risk.

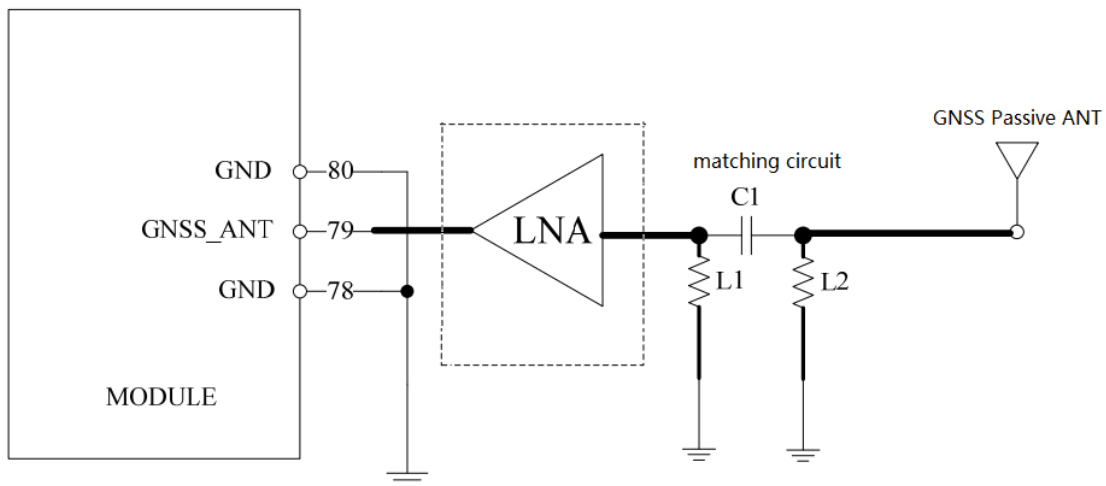

**Figure 3-32** GNSS passive antenna matching circuit diagram (GNSS\_ANT)

In above figures, the components C1 and L1, L2 are used for antenna matching, the values of the components can only be obtained after the antenna tuning usually, and they are provided by antenna vendor. C2 in Figure 3-19 is used for DC isolation. In active antenna circuit, users must use an external LDO/DCDC to provide VDD voltage whose value should be taken according active antenna characteristic, and VDD can be shut down to avoid consuming additional current when not being used. GNSS can be used by NMEA port. User can select NMEA as output through UART or USB. NMEA sentences are automatic and no command is provided. NMEA sentences include GSV, GGA, RMC,



GSA, and VTG. Before using GNSS, user should configure L506A in proper operating mode by AT command.

Please refer to related document for details. L506 can also get position location information through AT directly.

In the diagram above, component C1, L1 and L2 for antenna match, the element's value depends on the antenna after debugging. In figure 3-18, C2 for dc isolation. In the active antenna circuit, the user must use an external "/ DCDC VDD voltage, its value should be according to the properties of the active antenna, VDD can close to avoid without additional current consumption when using GNSS. In figure 3-19, the user can increase a external LNA gain to get better.

L506 merges GNSS (GPS/GLONASS) satellite and network information to provide a high-availability solution that offers industry-leading accuracy and performance. This solution performs well, even in very challenging environmental conditions where conventional GNSS receivers fail, and provides a platform to enable wireless operators to address both location-based services and emergency mandates.

- Tracking sensitivity: -159 dBm (GPS) -158 dBm (GLONASS)
- AcquisitionSensitivity: -148dBm
- Cold-start sensitivity: -142 dBm
- CN: C/N0 = S - (-170) S= Input Signal Intensity
- Accuracy (Open Sky) : 2.5m (CEP50)
- TTFF (Open Sky:) Hot start <1s Cold start 35s
- Receiver Type: 16-channel, C/A Code
- GPS L1 Frequency : 1575.42±1.023MHz
- GLONASS: 1597.5~1605.8 MHz
- BEIDOU: 1559.05~1563.14 MHz
- Update rate Default: 1 Hz
- GNSS data format: NMEA-0183
- GNSS Current consumption (WCDMA/Sleep mode) : 100mA (Total supply current)

#### Antenna Layout guideline

In layout design, antenna RF transmission line must ensure the characteristic impedance = 50 ohm. The characteristic impedance depend on substrate board, line width and the distance from the ground plane. As shown in figure 3-20 is the layout of antenna feed point of reference for clearance area.

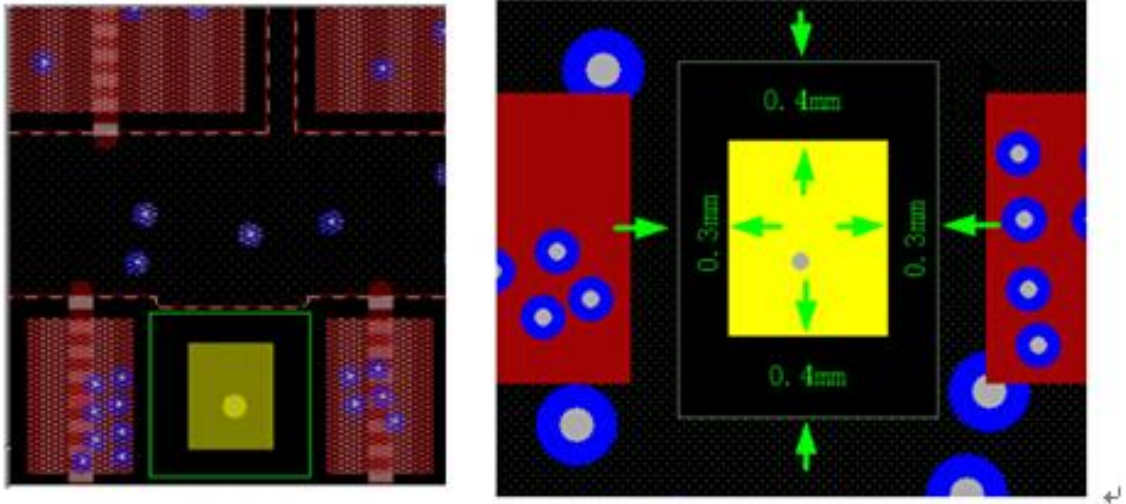

Figure 3-33 antenna feed point

## 4 Product characteristics

### 4.1 Absolute parameters

The following table shows the state of the absolute maximum work in abnormal situation. Exceed the limit value will likely result in permanent damage to the module.

Table 4-1 L506A absolute parameters

Parameter	Min.	Max.	Unit
VBAT absolute voltage parameter	-0.5	6.0	V
USB_VBUS absolute voltage parameter	-0.5	5.25	V
I/O absolute voltage parameter: PWRKEY, RESET, SPI, GPIO, I2C, PCM, UART, SD1_DET, USIM_DET	-0.3	2.1	V
I/O absolute voltage parameter: SD and USIM	-0.3	3.05	V

### 4.2 Operation condition

#### 4.2.1 Operation voltage

This product is a DC input voltage range of 3.4 V to 4.2 V, the typical value of 3.8 V, as shown in below table.

Table 4-2 Input DC voltage

Parameter	Min.	Typ.	Max.	Unit
VBAT Voltage	3.4	3.8	4.2	V
USB_VBUS Voltage	2.0	5.0	5.25	V

About L506A dc electric property, please refer to part 3.3 digital I/O characteristics.

#### 4.2.2 Work mode

Table 4-3 work mode

Mode	Description
Normal operation mode	(WCDMA/LTE) Sleep In this case, the current consumption of module will be reduced to the minimal level. In sleep mode, the module can still receive paging message and SMS.
	(WCDMA/LTE)) Software is active. Module is registered to the

	Idle	WCDMA/ LTE network, and the module is ready to communicate.
	(WCDMA) taking	Connection between two subscribers is in progress. In this case, the power consumption depends on network settings such as DTX off/on, FR/EFR/HR, hopping sequences, antenna.
	(WCDMA/LTE) Standby	Module is ready for WCDMA/LTE data transfer, but no data is currently sent or received. In this case, power consumption depends on network settings and /HSPA+ /LTE configuration.
	(WCDMA/LTE) Data transfer	There is WCDMA/LTE data transfer in progress. In this case, power consumption is related to network settings (e.g. power control level); uplink/downlink data rates
Minimum mode		AT command “AT+CFUN” can be used to set the module to a minimum functionality mode without removing the power supply. In this mode, the RF part of the module will not work or the USIM card will not be accessible, or both RF part and USIM card will be closed, and the serial port is still accessible. The power consumption in this mode is lower than normal mode.
Flight mode		Use the “AT + CFUN = 7” command or lower FLIGHTMODE pins, the module can be configured to flight mode under without removing the power supply condition. In this case, the RF part does not work, but still can use the serial port and USB, the power consumption is lower than normal working mode.
Power off		Through the “AT + CPOF” command or lower PWRKEY pin can power off L506A. At this mode, the module of internal power supply will be closed, and the system is stop running also. The UART and USB are unavailable.
Sleep mode		In sleep mode, the module power consumption to a minimum, but the module is still able to receive paging information and SMS.

### 4.2.3 current consumption

The power consumption in suspended mode and without USB connection is listed in the table below.

Table 4-4 working current consumption (VBAT=3.8V)

#### GNSS (Without USB)

(AT+CFUN=0)	@ -140dBm, Positioning, Typical: 72mA
<b>Power off</b>	
Power off current	20uA
<b>UMTS sleep/idle</b>	
WCDMA current (GNSS off, without USB)	Sleep mode @DRX=9 typical: 3.6mA Idle mode @DRX=9 typical: 19mA
<b>LTE Sleep/Idle</b>	
LTE supply current (GNSS off, without USB)	Sleep mode typical: 3.8mA Idle mode typical: TBD
<b>UMTS Talking</b>	
WCDMA B2	@power 24dBm typical: 665mA
WCDMA B5	@power 24dBm typical: 586mA
<b>HSDPA Data transmission</b>	
WCDMA B2	@power 24dBm typical: 560mA
WCDMA B5	@power 24dBm typical: 500mA
<b>LTE Data transmission</b>	
LTE-FDD B2	@1.4Mbps typical: 716mA @3Mbps typical: 656mA @5Mbps typical: 716mA @10Mbps typical: 722mA @20Mbps typical: 750mA
LTE-FDD B4	@1.4Mbps typical: 616mA @3Mbps typical: 656mA @5Mbps typical: 656mA @10Mbps typical: 687mA @20Mbps typical: 721mA
LTE-FDD B5	@1.4Mbps typical: 616mA @3Mbps typical: 656mA @5Mbps typical: 733mA @10Mbps typical: 766mA
LTE-FDD B13	5Mbps typical: 591mA @10Mbps typical: 597mA
LTE-FDD B17	5Mbps typical: 591mA @10Mbps typical: 597mA

## 4.3 Working and storage temperature

The operating temperature and storage temperature of L506A is listed in the following table.

Table 4-5 Operating temperature

Parameter	Min.	Typ.	Max.	Unit
Normal operation temperature	-30	25	80	°C
Extended operation temperature*	-40	25	85	°C
Storage temperature	-45	25	90	°C

**\*Note: Module is able to make and receive voice calls, data calls, SMS and make WCDMA/HSPA+/LTE traffic in -40°C ~ +85°C. Temperatures outside of the range -30°C ~ +80°C might slightly deviate from ETSI specifications.**

## 4.4 ESD performance

L506A is electrostatic sensitive device, therefore, the user in the production, assembly and operation of the module must pay attention to the electrostatic protection. L506A ESD performance parameters in the following table:

Table 4-6 ESD performance parameters (temperature 25 °C, humidity: 45%)

Net	contact	air
VBAT GND	±5KV	±10KV
Antenna port	±4KV	±8KV
UART	±2KV	±4KV
USB	±3KV	±6KV
Other PADS	±2KV	±4KV

## 5 Design guideline

This chapter provides a general design of the products instruction, the user can refer to design guidance for design, make products to achieve better performance.

## 5.1 General design rules and requirements

Users in the design of this product is peripheral circuit, the first to ensure the external power supply circuit can provide enough power supply capacity, And the requirements for high speed signal lines USB control 90 ohm + / - 10% difference impedance. For general signal interface, require the user to us in strict accordance with the requirements of design, in line with the interface signal level matching, in case the level of damage to the module. This product its own radio frequency index is good, customers need to design in accordance with the requirements the mainboard side antenna circuit and corresponding impedance control, otherwise it will affect the whole RF index.

## 5.2 Reference circuit

Request system board VPH\_PWR side power supply ability of power supply to achieve more than 2 A, meet the demand of modules, peak current, and the system side the power of the average current will reach more than 0.9 A. System board side power supply cord shall ensure enough line width, and wants to form a good return with the ground plane, moreover should increase in the power supply circuit design the method of micro level energy storage capacitor, guarantee the instantaneous power supply capacity, and the power supply ripple control within the 100 mv, the specific function of each functional module can be found in the corresponding description, overall reference circuit design please refer 《L506 reference design》 .

## 5.3 RF part design guideline

### 5.3.1 Early antenna design considerations

- Pre-project evaluation

The selection of the antenna position must first ensure that the antenna and the base station are kept in the horizontal direction, this produces the highest efficiency; Secondly, try to avoid placing the switch in the power supply or data line, chip and other devices or chips that produce electromagnetic interference. At the same time, the position of the hand can be avoided, so as to prevent the human body to produce attenuation; But also to reduce the radiation and the structure of the realization of the need to take into account. So, At the beginning of the design need to structure, ID, circuit, antenna engineers together to evaluate the layout.

- Antenna matching circuit

If the module's radio frequency port and the antenna interface need to be transferred, the main board circuit design, The design of microstrip line or strip line between the module RF test base and the antenna interface between the microstrip line or the strip line by characteristic impedance 50 ohm, at the same time, reserved double L type matching circuit; If the antenna's RF connector can be directly stuck in the module's RF test base, can save the module of the RF port and the antenna interface between the transfer.

## 5.4 EMC and ESD design advice

Users should take full account of the EMC problem caused by signal integrity and power integrity in the design of the whole machine, In the module of the peripheral circuit layout, for power and signal lines, etc., to maintain the spacing of 2 times line width. Can effectively reduce the coupling between the signal, so that the signal has a clean, the return path. When the peripheral power supply circuit is designed, the decoupling capacitor should be placed close to the module power supply pin, High frequency high speed circuit and sensitive circuit should be far from the edge of PCB, and the layout of the layout as far as possible to reduce the interference between each other, and the sensitive signal is protected. The circuit or device that may interfere with the operation of the system board is designed.

This product is embedded in the system board side, design, need to pay attention to the ESD protection, the key input and output signal interface, such as (U) SIM card interface need to be placed close to the protection of ESD devices. In addition to the

motherboard side, the user is required to design the structure and PCB layout, ensure that the metal shield is fully grounded, and set up an unobstructed discharge passage for the electrostatic discharge.



## 5.5 PCB Recommended land pattern

We recommend that users in the design of main board PCB DEF, In the middle of the 12 geothermal solder design according to size in below figure. Recommended at 87 of peripheral signal pads to the module with a length of 1.0 mm. Recommended PCB pads as shown in below.

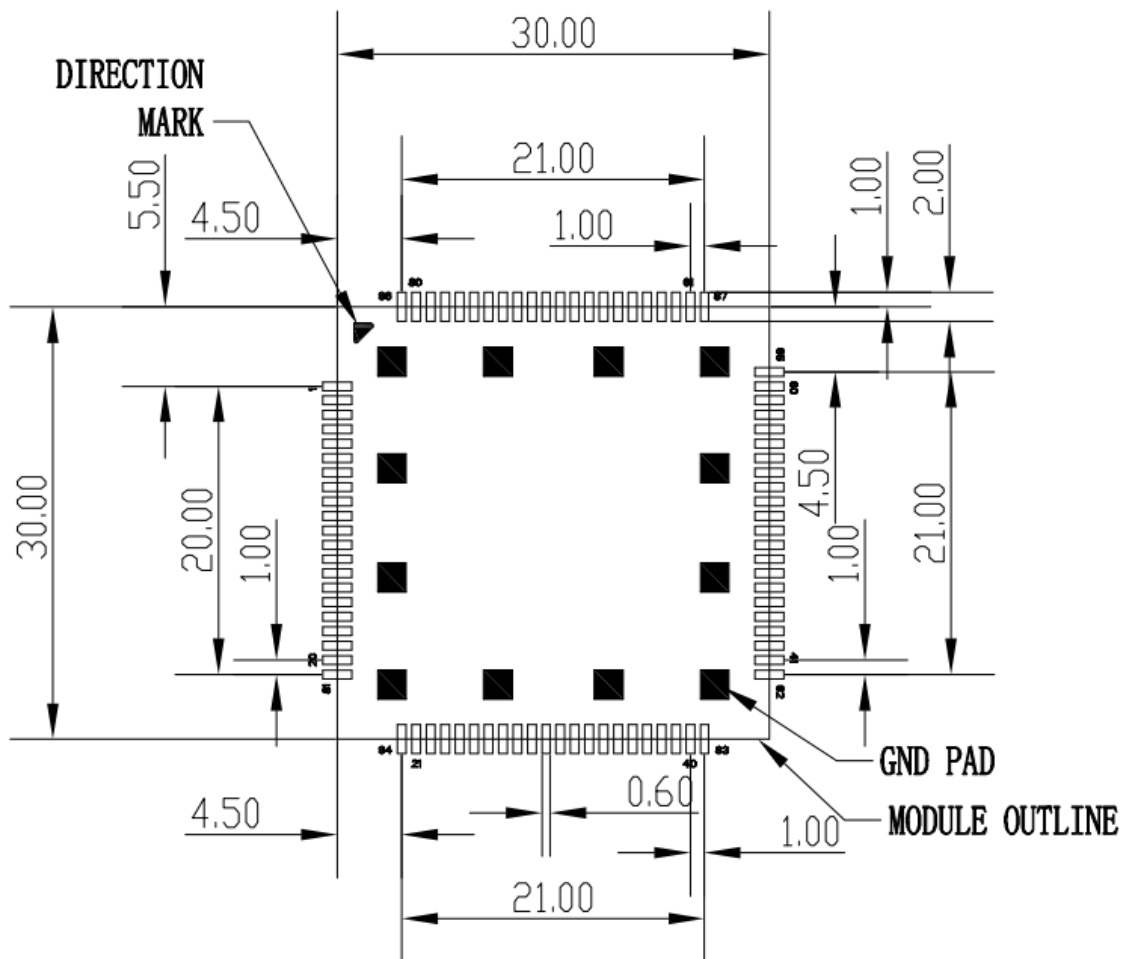

Figure 5-1 RECOMMENDED LAND PATTERN (Unit: mm) (detail A)

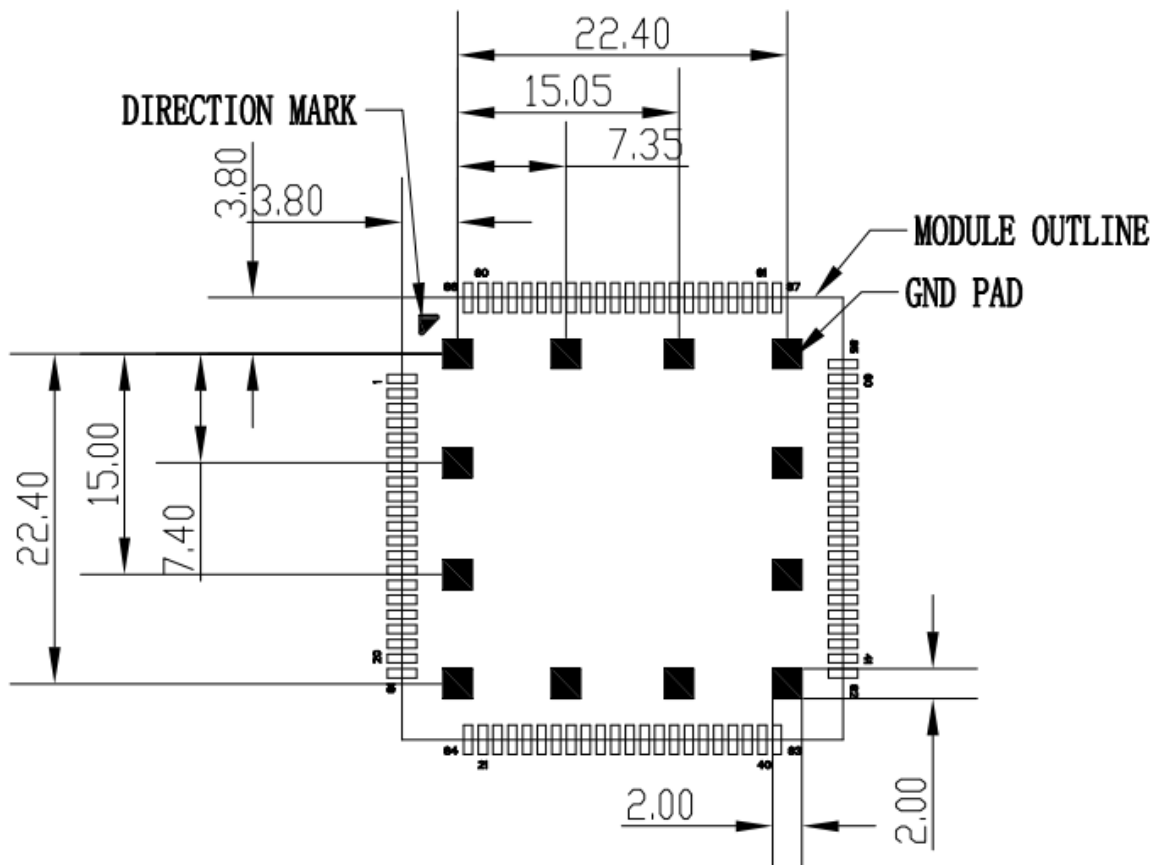

Figure 5-2 RECOMMENDED LAND PATTERN (Unit: mm) (detail B)

## 5.6 Products recommended upgrade

L506 default through the USB firmware updates, so products to facilitate the software update, when the design proposal to set aside the USB test points or interface to facilitate subsequent product of the firmware upgrade.

## 6 Manufacturers

### 6.1 Steel mesh design

- At the bottom of the module pad thermal, can be reduced by way of steel mesh openings, reduce the risk of short circuit between the thermal and the module of the module Pin, have certain effect;
- Module pad thermal welded steel mesh openings are recommended for reference. Figure 6-1 and Figure 6-2 is recommended for steel mesh and size.

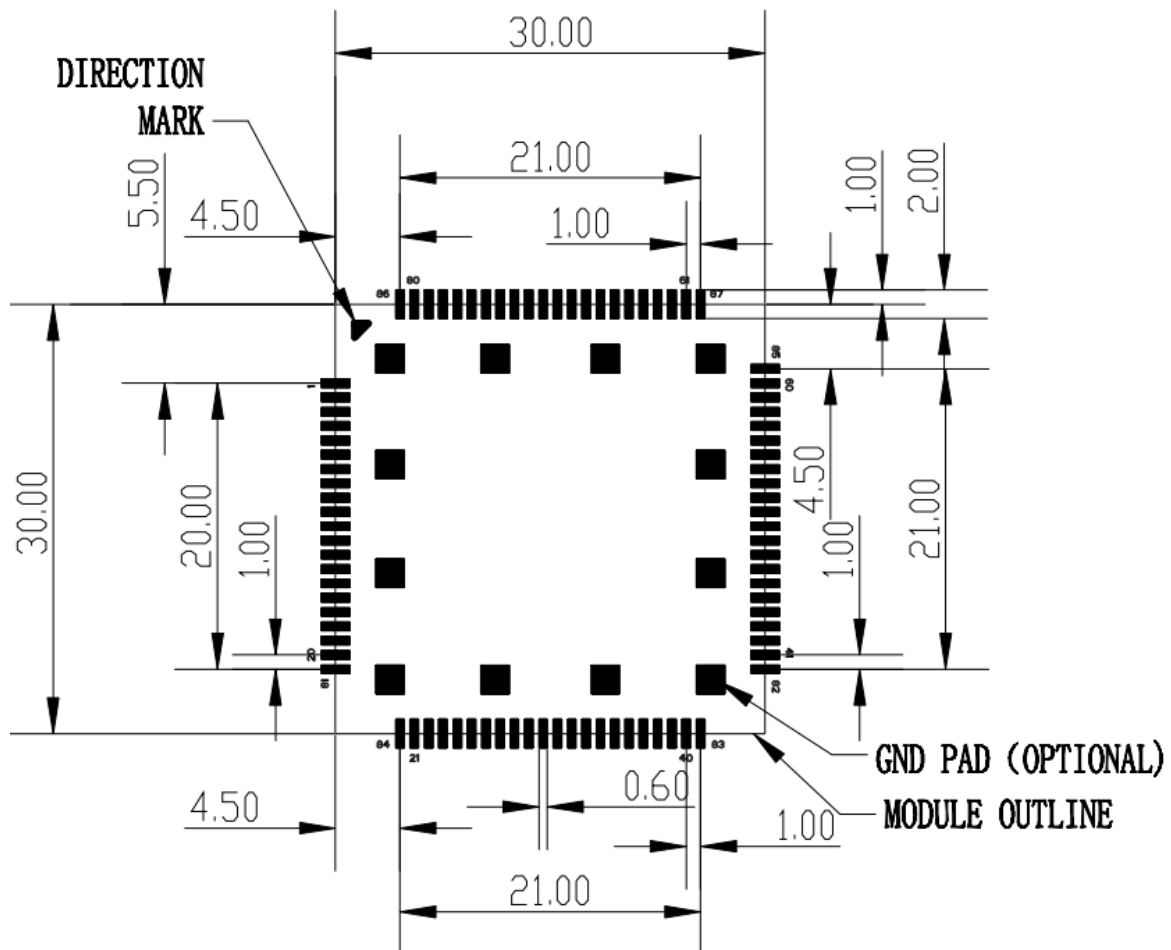

Figure 6-11 Steel mesh (unit mm)(detail A)

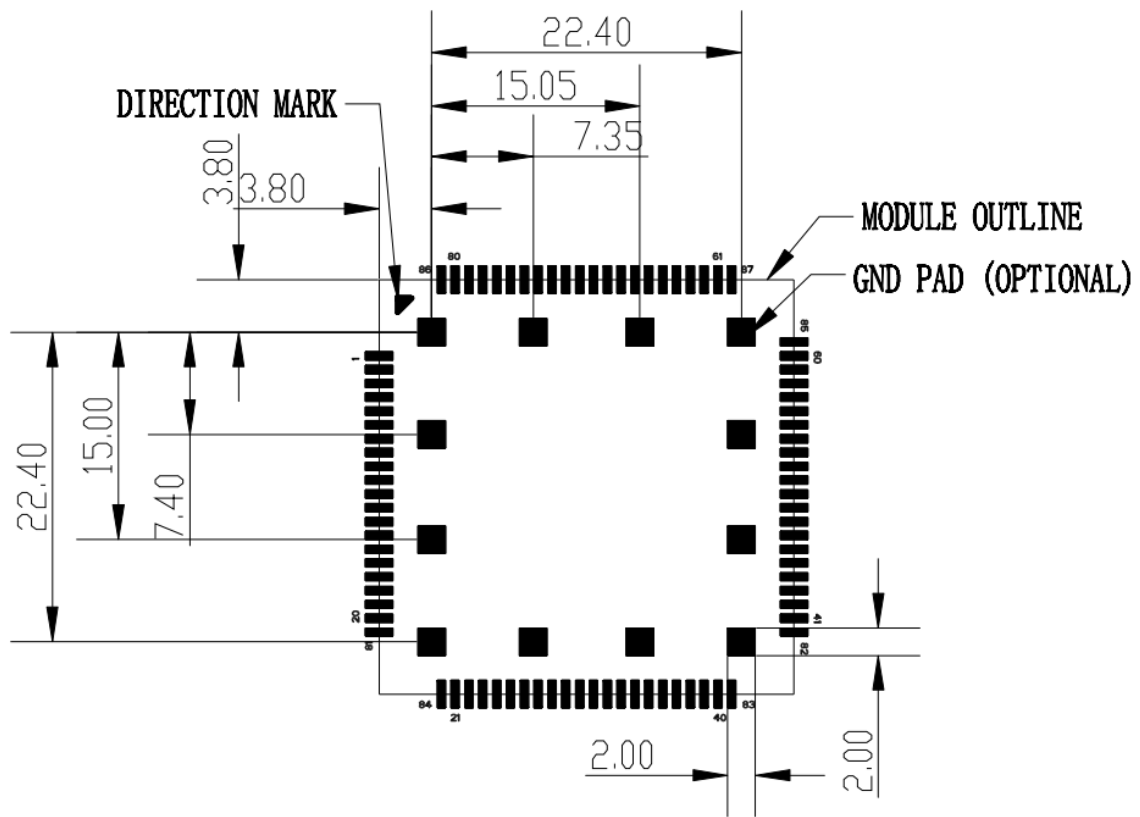

Figure 6-2 Steel mesh (unit mm) (detail B)

**Note:** The direction mark point only for identify the pin 1 position, should not embody in the steel mesh file.

## 6.2 Temperature curve

The temperature curve of the welding quality and material status influence, please pay special attention. Temperature rise speed should not be too fast, from room temperature to 150, the temperature rise rate is less than 3s. At the same time in more than 217 degrees, please try to keep time no more than 70 seconds, at intermediate values of 55 seconds is appropriate. The thermal shock strength is too general will lead to part of the device failure, resulting in a decline in yield and maintenance difficulty. And please control the maximum temperature of no more than 245 degrees, partial material, such as crystal at high temperature easy to occur the package rupture, cause unable to play the problem, and then affect the function of the product, The temperature can be set using the curve shown in table 6-1.

Table 6-1 Temperature curve

Lead-free process temperature curve		
Stage	Temperature	time
Preheat	Temperature rise from room temperature to 150	rate of temperature rising <math>< 3 / ^\circ\text{C s}</math>
keep warm	150 $^\circ\text{C}$ ~200 $^\circ\text{C}$	40~110 s
Welding	< 217 $^\circ\text{C}$	40~70 s
	< 230 $^\circ\text{C}$	15~45 s
	Peak temperature	MAX: 245 $^\circ\text{C}$ MIN: 230 $^\circ\text{C}$

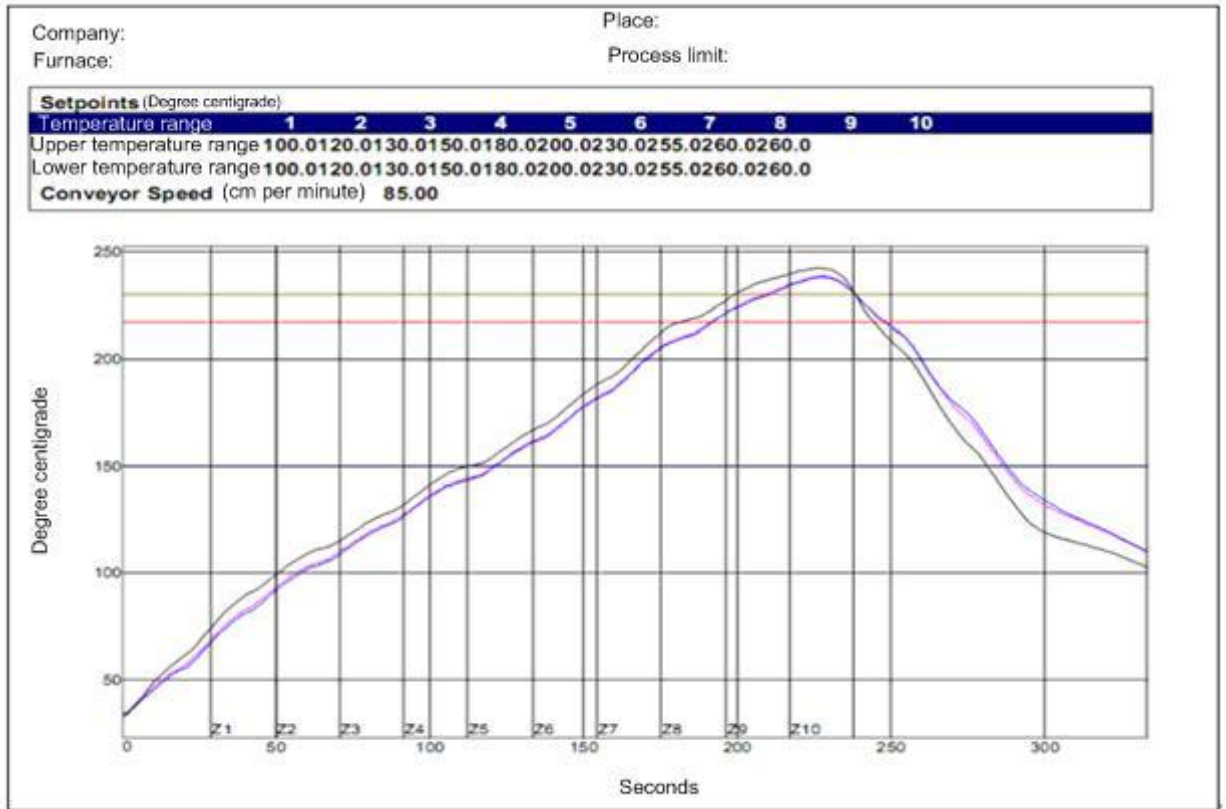

PWI= 74%	Maximum temperature ascending slope	Maximum temperature descending slope	Preheat time 150200C	Time of the reflow temperature or above271C	Upper limit	Total time	/230C
Module edge point	1.3 -34%	-1.9 55%	49.6 -72%	57.4 16%	238.7 16%	29.5 -3%	
Module bottom	1.3 -35%	-1.8 60%	49.1 -74%	56.2 8%	238.1 8%	28.2 -12%	
Chip	1.4 -29%	-2.1 46%	52.7 -64%	63.6 57%	242.5 66%	39.6 64%	
Temperature difference	0.1	0.3	3.6	7.4	4.3	11.4	

Process limit

Define Your Own Spec			
Statistic name	Lower limit	Upper limit	Unit
Maximum temperature ascending slope (target: 2.0) (Time distance = 20 seconds)	0.0	3.0	Degree per second
Maximum temperature descending slope (Time distance = 20 seconds)	-5.0	-1.0	Degree per second
Preheat time 150200C	40	110	Seconds
Time of the reflow temperature or above271C	40	70	Seconds
Maximum temperature	230	245	Degree centigrade
Time of the temperature above 230C	15	45	Seconds

Figure 6-3 The reference temperature curve

# 7 Package Storage information

## 7.1 Package information

### 7.1.1 Tape and reel information

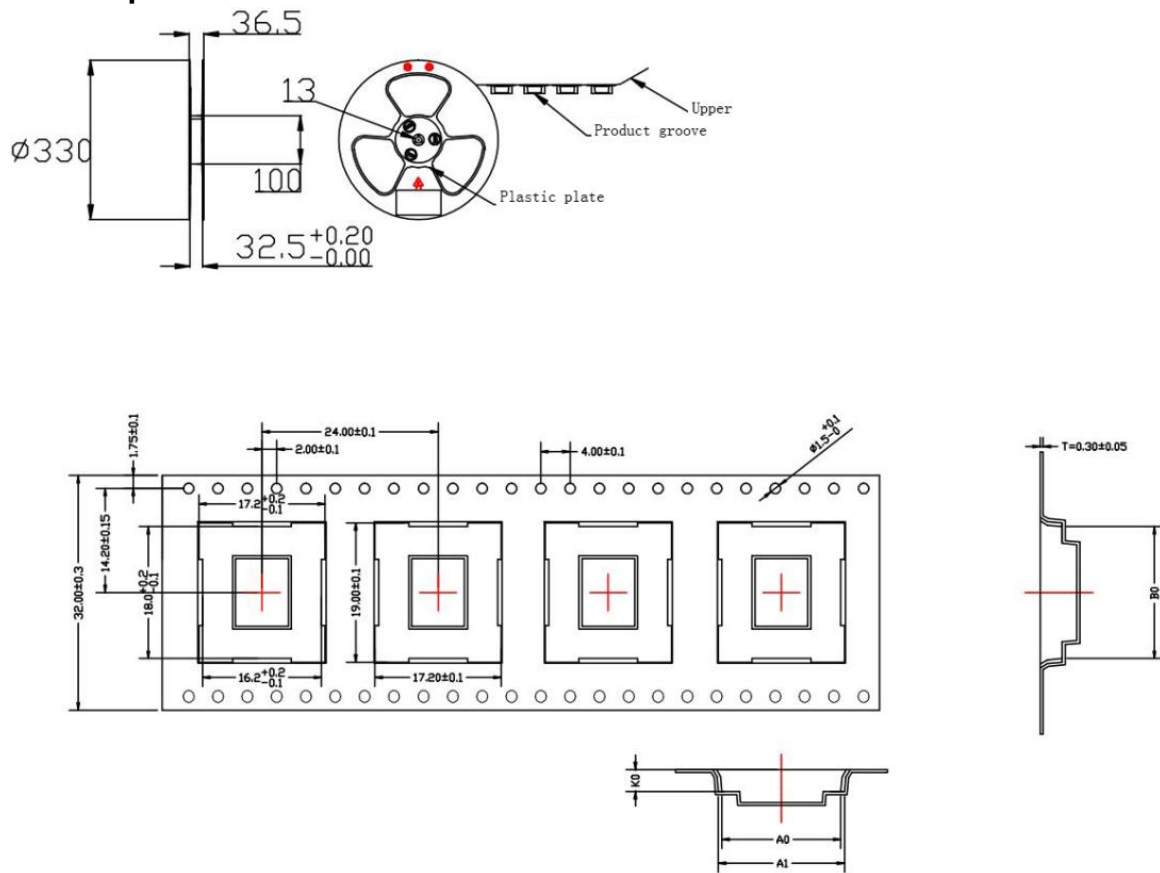

Figure 7-1 Tape and reel information

### 7.1.1 Package information

L506A packing diagram is as follows, every 4 volumes of material packed in a case between each volume of material has a bubble mat do isolation protection. Specific as shown in the figure below:

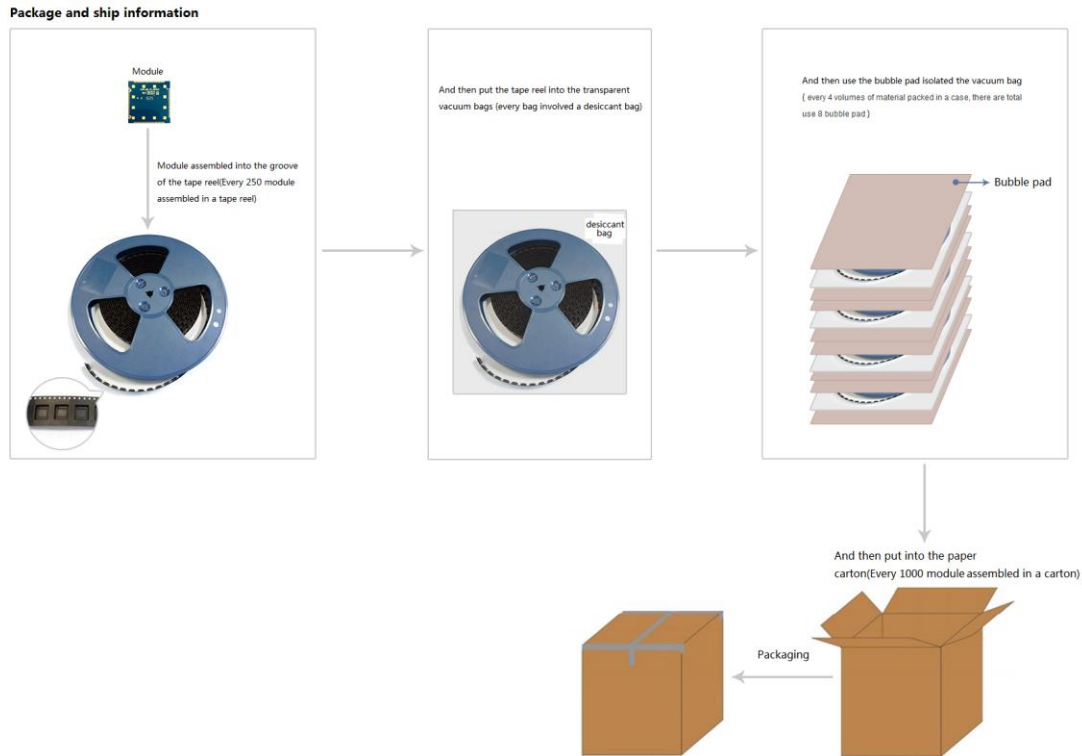

Figure 7-2 Package and ship information

## 7.2 Bagged storage conditions

L506 shipments in the form of vacuum sealing anti-static bag. Module of storage need to follow the following conditions: Environment below 40 Degrees Celsius temperature, air humidity is less than 90% of cases, the module can be in vacuum sealed bags for 12 months. Conditions set the storage environment Suggestions with reference to the following form.

Table 7-1 Storage conditions (less than 90% humidity of the air vacuum sealed packaging)

Parameter	Min.	Typ.	Max.	Unit
Storage temperature	-45	25	90	°C

When on the vacuum bags, if meet the following conditions, the module can be directly for reflow soldering (furnace temperature setting reference 6.2 furnace temperature curve) or other high temperature process:

- Module temperature below 30 degrees c, the air humidity is less than 60%, factory within 72 hours to complete the SMT.
- The humidity is less than 10%.

If the module is in the following conditions, to be baked before SMT:

- When the environment temperature is 23 degrees Celsius (allow upper and lower volatility of 5 degrees Celsius), humidity index greater than 10%.
- When open vacuum bags, module temperature below 30 degrees Celsius, air humidity is less than 60%, but the factory have not finished the SMT within 72 hours.



- When open the vacuum bags, module storage air humidity is more than 10%.

If modules need baking, please under 125 degrees Celsius (allowing fluctuations of 5 degrees Celsius) up and down bake for 48 hours.

Any Changes or modifications not expressly approved by the party responsible for compliance could void the user's authority to operate the equipment.

#### **FCC Radiation Exposure Statement:**

This equipment complies with FCC radiation exposure limits set forth for an uncontrolled environment .This equipment should be installed and operated with minimum distance 20cm between the radiator& your body.

#### **FCC Label Instructions:**

If using a permanently affixed label, the modular transmitter must be labeled with its own FCC identification number, and, if the FCC identification number is not visible when the module is installed inside another device, then the outside of the device into which the module is installed must also display a label referring to the enclosed module. This exterior label can use wording such as the following: "Contains Transmitter Module FCC ID: 2AK9DL506" or "Contains FCC ID: 2AK9DL506". Any similar wording that expresses the same meaning may be used.The Grantee may either provide such a label, an example of which must be included in the application for equipment authorization, or, must provide adequate instructions along with the module which explain this requirement.

Single Modular Approval. Output power is conducted. This device is to be used in mobile or fixed applications only. Antenna gain including cable loss must not exceed 10.42 dBi in Band 5, 9.5 dBi in Band 2, 7 dBi in Band 4, 12.18 dBi in Band 13 and 11.77 dBi in Band 17 for the purpose of satisfying the requirements of CFR 47 2.1043 & 2.1091. The antenna(s) used for this transmitter must be installed to provide a separation distance of at least 20 cm from all persons and must not be co-located or operated in conjunction with any antenna or transmitter, except in accordance with FCC multi-transmitter evaluation procedure. Compliance of this device in all final product configurations is the responsibility of the Grantee. Installation of this device into specific final products may require the submission of a Class II permissive change application containing data pertinent to RF Exposure, spurious emissions, ERP/EIRP, and host/module authentication, or new application if appropriate.