

**How it works**

**Light Genie™ Includes a Transmitter and 12 output Receiver.**  
**The Receiver operates with 5 zones of control.**

**Each Zone** has the ability to be remotely turned on or off, adjusted for brightness, and set to one of over 20 different **lighting effects.** (Fig 1.)

**Lighting effects to select from:** Constant on, flashing, strobe effect, sequential lighting, flickering, and more.. There are more than 20 lighting effects to choose from. See enclosed chart.

**ZONES**

- Zone 1 controls outputs 1 and 2 - (2 Outputs)
- Zone 2 controls outputs 3 and 4 - (2 Outputs)
- Zone 3 controls outputs 5 and 6 - (2 Outputs)
- Zone 4 controls outputs 7, 8 and 9 - (3 Outputs)
- Zone 5 controls outputs 10, 11 and 12 - (3 Outputs)

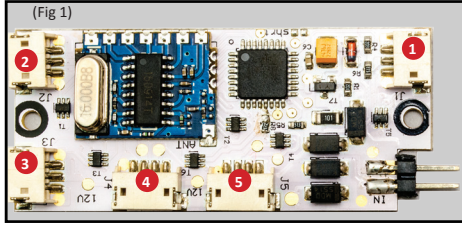

**Light Genie™ Supplemental Products**

- No. 025001 – Multi-Action Transmitter w/LCD (Control 4 Receivers)
- No. 025201 – 1 Amp AC Power Supply
- No. 025300 – LED Red (4 Pack)
- No. 025301 – LED Bright White (4 Pack)
- No. 025302 – LED Golden White (4 Pack)
- No. 025303 – LED Amber (4 Pack)
- No. 025320 – LED Mini White (4 Pack)
- No. 025321 – LED Mini Red (4 Pack)
- No. 025322 – LED Mini Amber (4 Pack)
- No. 025323 – LED Mini Green (4 Pack)
- No. 025100 – 3 Pin Connectors w/ 10" Leads (6 Pack)
- No. 025101 – 4 Pin Connectors w/ 10" Leads (2 Pack)

- 12 – Resistors for LEDs and 3.5V Bulbs
  - 2 – AAA Batteries
  - 1 – Velcro Strip
  - 2 – Mounting Screws
  - 2 – 4-Pin Connectors w/Leads
  - 3 – 3-Pin Connectors w/Leads
  - 1 – 2-Pin Power Connector w/Leads
  - 1 – Genie Transmitter Remote
  - 1 – Genie Receiver
- Light Genie™ Contents



**PLEASE READ INSTRUCTIONS IN THEIR ENTIRETY PRIOR TO USE**



No. 025000

Patent Pending

**Before Starting**

Do not tamper or modify any of the Light Genie™ components. Keep instructions for later use.

**Get Started**

Light Genie™ includes the following; **Genie Receiver Board, Lighting Plugs, Power Plug, and Wireless Transmitter.** Combined with any light on your project, wireless radio control and lighting effects are easily commanded.

**Connect Lights to the Genie Receiver**

**Before starting, make sure all power is off to your project and the Genie receiver is unplugged.**

Use the Light Genie™ plugs provided and connect with any desired LED/Bulb fixture you wish to use with your project.

LED's are directional. Please be sure the positive leg is connected to the blue wire (common wire).

Simply take the lead wires from the Light Genie™ plug and leads from your lighted accessory, twist the leads together. Make sure the copper strands have a solid interlocking twist. Wrap the connection in electrical tape for insulation & to prevent a short circuit. Soldering may be used for a more permanent connection.

Plug the Light Genie™ Plugs into the Genie Receiver. (Fig 2)

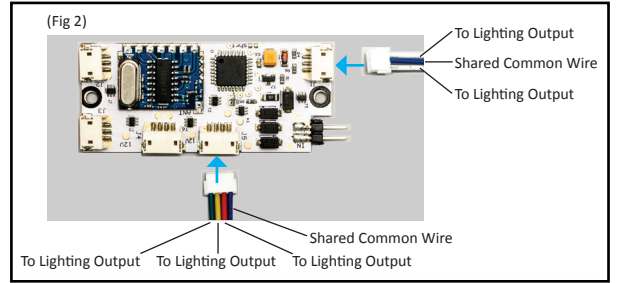

DCC Notes  
 Light Genie™ is DCC equipped, and does not need an additional decoder purchase. See our website for more information about DCC usage and additional features.

**WARNING: PARALLEL WIRING SHOULD NOT BE ATTEMPTED.**  
 If your project requires parallel wiring, visit our website or contact MRC for more information.

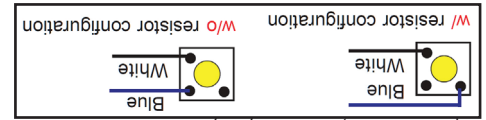

Light Genie™ surfaced mounted LEDs come with a built in resistor, but can easily be configured to operate without, so that they may be used in a series.  
 A combination of bulbs and LED's may be used. Performance may vary based on project configurations.  
 Some LED's come with a resistor pre-wired. Using multiple LEDs in a series will result in dimmer lighting. To increase brightness, remove their respective resistor(s) to make them brighter. Keep in mind, one is still required as mentioned previously.  
 Light Genie™ is equipped with a power regulator to protect your lights. Using a higher voltage power supply (beyond 13v), will NOT increase the brightness of any lights.  
 Remote Transmitter = 90' Operational Range  
 Incandescent Bulb Specifications & LED Specifications  
 Up to 24 Bulbs with Series wiring (12-14v – 30 mA)  
 Up to 48 LEDs/3.5V Bulbs with Series wiring (20 mA)  
 Resistor Usage for LED's and 3.5v Incandescent Bulbs  
 One to Three LEDs/3.5V Bulb in a Series (per Output) – One Resistor Required  
 Four LEDs/3.5V Bulb in a Series (per Output) – NO Resistor Required

**Technical Specifications/Notes**  
 Light Genie™ Receiver  
 Maximum Output = 1 Amp/Light Genie™ Receiver  
 Input = 12v/Maximum = 18v  
 Maximum 100mA per Output Channel/12v per Output  
**WARNING: Only Use 12-16V (30mA) Incandescent Bulbs**  
 Supplied Resistors = 470 ohm each

## Powering Light Genie™ Wireless Receiver & Control Set

After connecting all the desired lighted accessories to the Light Genie™ receiver, supplying power to the receiver and project lights is easy.

### Check to make sure all the power is off on your project

Using the supplied Genie 2-Pin Power Plug (note larger plug size), connect the lead wires to the optional Light Genie™ 1-amp AC Wall Adaptor (#025201); existing DC power terminals, AC power terminals, or DCC power source. (Fig 3).

Plug the terminal into the power plug port.

Make sure to use proper connection technique to avoid accidental electrical shorts from cross wiring.

(Fig 3)

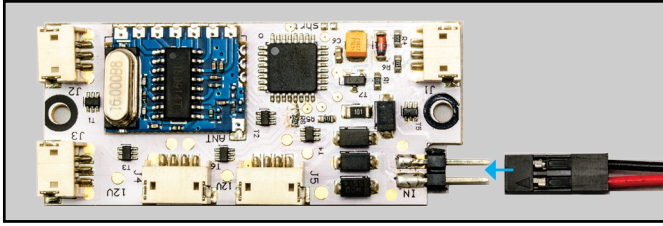

### Mounting Light Genie™ Wireless Receiver

After all connections are complete. Select the desired mounting location for the Genie Receiver. Apply the VELCRO® strip to the flat side of the board. Affix to mounting area. Use the two screws provided to secure the receiver. Be careful not to tighten the screws all the way.

### Power Up Light Genie™ Receiver and Transmitter

After all plugs are connected, and the receiver is properly mounted. It is safe to power on the Light Genie™ receiver by connecting the power source to an outlet. All lights will turn on once the receiver is powered.

### Binding The Light Genie™ Receiver & Transmitter

The Light Genie™ receiver and transmitter must bind prior to operation.

1. Install two AAA batteries into the transmitter. If batteries are already installed, remove and re-install. The LED on the transmitter will begin to flash.
2. Plug the 12v power supply into Light Genie to ensure power is on.
3. Binding is complete when the LED light has stopped flashing (off). If binding fails, repeat the above procedure.
4. Press any of the zones (utilized). The lighting feature should turn on/off.

Light Genie™ is now operational. The receiver and transmitter will remain bonded until the batteries are removed. If you have multiple Light Genie™ sets, repeat the above steps.

### Changing Light Effects and Light Rates

1. Press buttons ▲ and ▼ at the same time. All zones will shut off (lights will be out). This indicates you are in light effect mode.
2. Press the zone # once to set its lighting effect. The zone will light up.
3. Cycle through the lighting effects, by pressing the zone # repeatedly. Observe each light effect after pressing the zone number.
4. To change the light rate speed, press ▼ to slow the light rate or press ▲ increase the light rate.
5. To set other zones, simply repeat step 2 and step 3.
6. Once all zones are set. Press buttons ▲ and ▼ at the same time. All zones will light up. This indicates you are out of light effect mode.

Light Effect Chart		
Effect #	Light Effect	Applications
0	On/Off	
1	Sequential Flash w/Pause	Arrow Lighting
2	Crossing Signal/Traffic Street Light*	Railroad Crossing Signal/Street Traffic Lights
3	Alternating Flash - Always On	Police Car – Head/Tail Lights
4	Simultaneous Flash	Warning Lights, Towers, Runway Lights
5	Sequential Flash	Roadside Flashers
6	Gyra light	
7	Gyra light on at the same time	
8	Oscillation	Cell Phone Towers/Airplanes
9	Oscillation (Simultaneous)	
10	Stepped Lighting	Dim-Medium-Bright Lighting Cycle
11	Stepped Lighting (Parralled)	
12	Single Strobe (Varied/Alternating)	
13	Single Strobe (Simultaneous)	
14	Double Strobe (Varied/Alternating)	
15	Double Strobe (Simultaneous)	
16	Rotating Beacon	
17	Rotating Beacon (Simultaneous)	
18	Flicker (Pattern 1)	Camp Fire/Fire Place/Furnace/Foundry
19	Flicker (Pattern 2)	Gas Lamp/TV
20	Varied Intensity	Arc Welding

## Command Light Genie™ Wireless Transmitter

Time for Light Genie™ to grant your wishes. Use the 2.4ghz remote to control each of the 5 zones on a single Light Genie™. Turn each lighting output On/Off, Brighten/Dim, Flash, Strobe...whatever lighting effect you can think, Light Genie can grant. Follow the chart provided in this instruction booklet.

### Operation

To turn on or off a zone, simply press the desired zone #.

To control dimming/brightness of the last used zone. Press ▼ to dim the zone. Press ▲ to brighten the zone.

Light Genie™ Transmitter Function Key Table		
Key	Operation Mode	Light Effect Mode
1	Zone 1 On/Off	Change Light Effect (Zone 1)
2	Zone 2 On/Off	Change Light Effect (Zone 2)
3	Zone 3 On/Off	Change Light Effect (Zone 3)
4	Zone 4 On/Off	Change Light Effect (Zone 4)
5	Zone 5 On/Off	Change Light Effect (Zone 5)
6	Master Power On/Off	Reset Current Zone to Default
▼	Dim Light Zone	Decrease Zone Light Rate
▲	Brighten Light Zone	Increase Zone Light Rate



This device complies with Part 15 of the FCC Rules. Operation is subject to the following two conditions:

(1) This device may not cause harmful interference, and (2) This device must accept any interference received, including interference that may cause undesired operation.

**WARNING:** Changes or modifications not expressly approved by the party responsible for compliance could void the user's authority to operate the equipment.

**NOTE:** This equipment has been tested and found to comply with the limits for a Class B digital device, pursuant to Part 15 of the FCC Rules. These limits are intended to provide reasonable protection against harmful interference in a residential installation. This equipment generates uses and can radiate radio frequency energy and, if not installed and used in accordance with the instructions, may cause harmful interference to radio communications. However, there is no guarantee that interference will not occur in a particular installation. If this equipment does cause harmful interference to radio or television reception, which can be determined by turning the equipment off and on, the user is encouraged to try to correct the interference by one or more of the following measures:

- Reorient or relocate the receiving antenna.
- Increase the separation between the equipment and receiver.
- Connect the equipment into an outlet on a circuit different from that to which the receiver is connected.
- Consult the dealer or an experienced radio/TV technician for help.

#### RF WARNING STATEMENT:

The device has been evaluated to meet general RF exposure requirement. The device can be used in portable exposure condition without restriction.

### Series Wiring Instructions

#### Using Multiple LEDs/Bulbs per Output

Lights may be configured individually or in a series. Most LED's are low voltage (3v), which require a resistor to be installed with typical 12v power supplies. Depending on the LED product used for your project, there may be pre-installed resistors. If not, Light Genie™ comes with resistors to install with your LED's.

Adding resistors to an LED/3.5v Bulb, protects the lights and receiver. This will properly match the voltage for each Light Genie™ output. 12v - 14v bulbs do not require a resistor when used individually. Please see Fig.4

**WARNING: PARALLEL WIRING SHOULD NOT BE ATTEMPTED.**

If your project requires parallel wiring, visit our website or contact MRC for more information.

The diagram below (Fig 4.) is an example of various Light Genie™ applications and wiring.

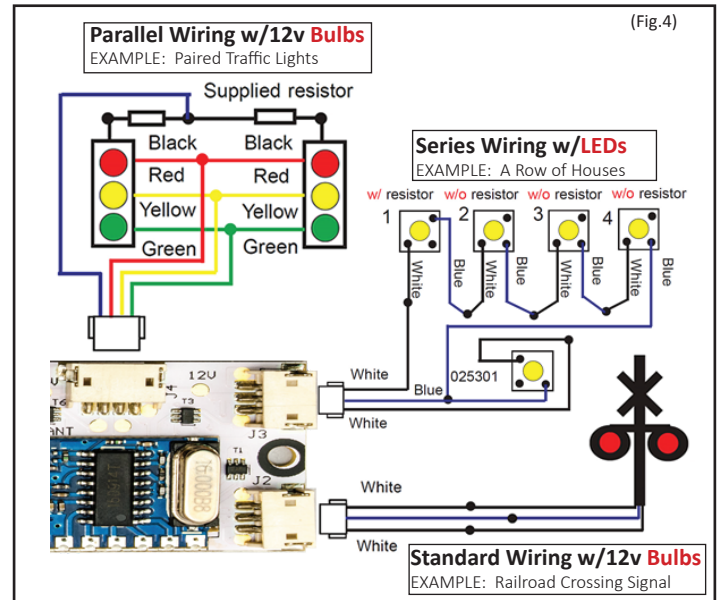

For more zone application examples using Light Genie™ visit [www.modelrectifier.com](http://www.modelrectifier.com)