

CROSLEY

CR6002A

Revolution

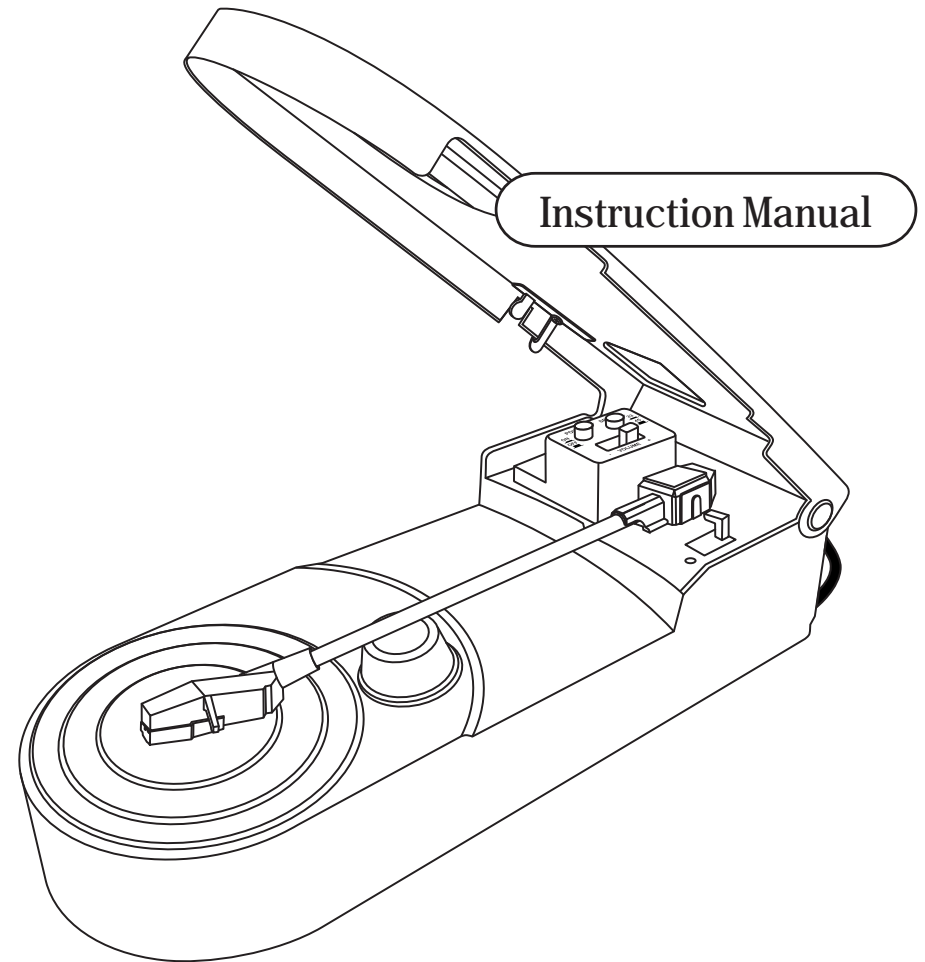

General

Transporting

To safely transport your Revolution, follow the steps below to prevent damage to your unit.

- 1 Place protective needle cover over needle.
- 2 Place the 45rpm adapter on the revolution as shown below

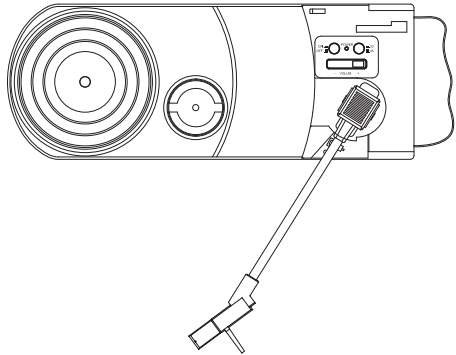

- 3 Move the TONE ARM from the ARM REST and position it over the 45rpm adapter and align the TONE ARM with the grooves in the 45rpm adapter as shown below.

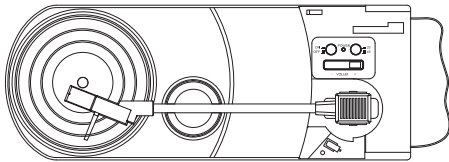

- 4 Gently press TONE ARM into grooves on 45rpm adapter.
- 5 Close the LID and check to make sure it is secure.

Troubleshooting

There is no Power

- 1 Make sure unit is plugged in correctly.
- 2 Replace batteries
- 3 The unit is not turned on: press the POWER button to ON Position.

There is no Sound

- 1 Slide the VOLUME CONTROL to raise volume.
- 2 Check to make sure headphones are not plugged into the unit.

No signal on FM Transmitter

- 1 Make sure TRANSMITTER SWITCH is on the ON position.
- 2 Make sure the unit and the FM tuner are set to the same frequency.
- 3 Check that the distance between the two is 20 feet or less.
- 4 Remove obstructions to minimize interference.
- 5 Try moving the Revolution closer to the FM tuner to reduce signal interference.

WARNING:

TO PREVENT FIRE OR SHOCK HAZARD, DO NOT EXPOSE THIS APPLIANCE TO RAIN OR MOISTURE. DO NOT REMOVE COVER. PILOT LAMPS SOLDERED IN PLACE. NO USER SERVICEABLE PARTS INSIDE. REFER SERVICING TO QUALIFIED SERVICE PERSONNEL.



The lightning flash with arrowhead symbol, within an equilateral triangle, is intended to alert user to the presence of uninsulated "dangerous voltage" within the product's enclosure that may be of sufficient magnitude to constitute risk of electric shock to persons.

CAUTION

**RISK OF ELECTRIC SHOCK
DO NOT OPEN**

CAUTION: TO REDUCE THE RISK OF ELECTRIC SHOCK, DO NOT REMOVE COVER (OR BACK). NO USER - SERVICEABLE PARTS INSIDE. REFER SERVICING TO QUALIFIED SERVICE PERSONNEL.



The exclamation point within an equilateral triangle is intended to alert user to the presence of important operating and maintenance (servicing) instruction in the literature accompanying the appliance.

Specification

Power source	: AC Adaptor AC120V/DC 9V 600mA
Power Consumption	: 6W
Antenna	: Built-in antenna for FM TRANSMITTER
Speed	: 33 1/3, 45 RPM
Speaker	: 28 x 40 mm 8ohm 2W
Audio output	: 600mW
Replacement Needle	: NP4
FM Transmitter Frequency	: 88.1MHz / 89.9MHz

* DESIGN AND SPECIFICATIONS SUBJECT TO CHANGE WITHOUT NOTICE.

Basic Operation

Turntable

- 1 Press the POWER button to turn the unit on.
- 2 Set the SPEED CONTROL SWITCH to the correct speed (33-1/3 or 45) for the selected record.
- 3 Slide the LID LOCK towards the rear of the unit to open the lid.
- 4 Lift the TONE ARM from its rest and gently move it to the right until it clicks into the ARM LOCK as shown below.

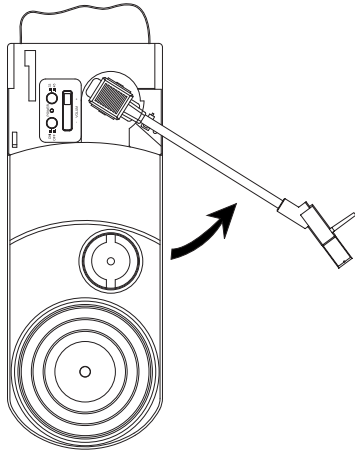

- 5 Remove the 45rpm adapter from the unit. If you are playing a 45 rpm record, place the adapter on the spindle.
- 6 Place record on the turntable.
- 7 Gently move the tone arm from the ARM LOCK and lower it to the desired starting point on the record.
- 8 Slide the VOLUME CONTROL to adjust the volume level.
- 9 At the end of the record, lift the TONE ARM from the record and return it to the ARM REST.

FM Transmitter

This unit is equipped with a built in FM transmitter. This feature allows the user to listen to their albums on any FM radio within approximately 15-20 feet. To use this feature, follow the instructions below.

- 1 Slide the TRANSMITTER ON/OFF switch to the ON position.
- 2 Slide the FREQUENCY SELECT switch to either 88.1 or 89.9 MHz.
- 3 Adjust the tuner on your FM radio to match the selected frequency from step 2.
- 4 Follow the instructions for Turntable Operation on the left side of this page.
- 5 Adjust the volume of your FM radio accordingly.

Notes:

- 1 Switch between the two frequencies listed above to determine which gives you the best signal for your location.
- 2 The maximum range of the FM Transmitter is approximately 20 feet, depending on your location.
- 3 For best performance, a clear line of sight between the Revolution and your FM radio is recommended.

Control Locators

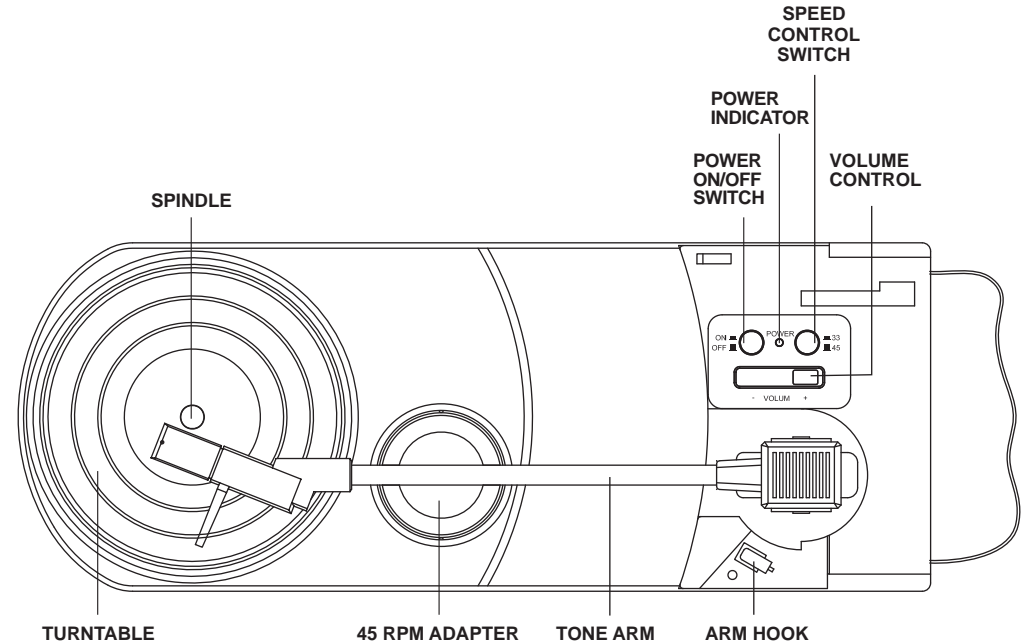
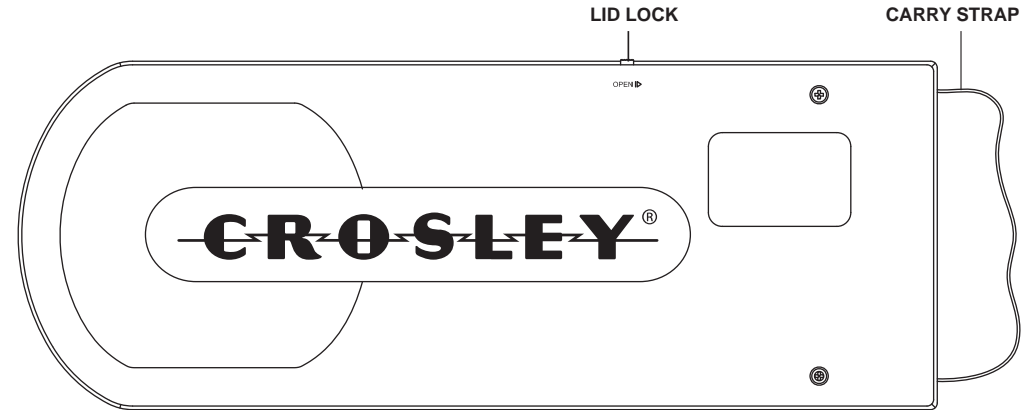

IMPORTANT SAFETY INSTRUCTION

PLEASE READ CAREFULLY ALL THE FOLLOWING IMPORTANT SAFEGUARDS THAT ARE APPLICABLE TO YOUR EQUIPMENT

1. Read Instructions - All the safety and operating instructions should be read before the product is operated.
2. Retain instructions - The safety and operating instructions should be retained for future reference.
3. Heed Warnings - All warnings on the product and in the operating Instructions should be adhered to.
4. Follow Instructions - All operating and use instructions should be followed.
5. Cleaning - Unplug this product from the wall outlet before cleaning. Do not use liquid cleaners or aerosol cleaners. Use a damp cloth for cleaning.
6. Attachments - Do not use attachments not recommended by the product manufacturer as they may cause hazards.
7. Water and Moisture - Do not use this product near water - for example, near a bath tub, wash bowl, kitchen sink, or laundry tub; in a wet basement; or near a swimming pool; and the like.
8. A product and cart combination should be moved with care. Quick stops, excessive force, and uneven surfaces may cause the product and cart combination to overturn.
9. Ventilation - Slots and openings in the cabinet are provided for ventilation and to ensure reliable operation of the product and to protect it from overheating, and these openings must not be blocked or covered. The openings should never be blocked by placing the product on a bed, sofa, rug, or other similar surface. This product should not be placed in a built - in installation such as a bookcase or rack unless proper ventilation is provided or the manufacturer's instructions have been adhered to.
10. Power Sources - This product should be operated only from the type of power source indicated on the marking label, if you are not sure of the type of power supply to your home. Consult your product dealer or local power company. For products intended to operate from battery power, or other sources, refer to the operating instructions.
11. Grounding or Polarization - This product may be equipped with a polarized alternating-current line plug (a plug having one blade wider than the other). This plug will fit into the power outlet only one way. This is a safety feature. If you are unable to insert the plug fully into the outlet try reversing the plug. If the plug should still fail to fit, contact your electrician to replace your obsolete outlet. Do not defeat the safety purpose of the polarized plug.
12. Power - Cord Protection - Power - supply cords should be routed so that they are not likely to be walked on or pinched by items placed upon or against them, paying particular attention to cords at plugs, convenience receptacles, and the point where they exit from the product.
13. Lightning - For added protection for this product during a lightning storm, or when it is left unattended and unused for long periods of time, unplug it from the wall outlet and disconnect the antenna or cable system. This will prevent damage to the product due to lightning and power - line surges.
14. Power Lines - An outside antenna system should not be located in the vicinity of overhead power lines or other electric light or power circuits, or where it can fall into such power lines or circuits. When installing an outside antenna system, extreme care should be taken to keep from touching such power lines or circuits as contact with them might be fatal.
15. Overloading - Do not overload wall outlets, extension cords, or integral convenience receptacles as this can result in a risk of fire or electric shock.
16. Object and Liquid Entry - Never push objects of any kind into this product through openings as they may touch dangerous voltage points or short - out parts that could result in a fire or electric shock. Never spill liquid of any kind on the product.
17. Servicing - Do not attempt to service this product yourself as opening or removing covers may expose you to dangerous voltage or other hazards. Refer all servicing to qualified service personnel.
18. Damage Requiring Service - Unplug this product from the wall outlet and refer servicing to qualified service personnel under the following conditions:
 - a. When the power-supply cord or plug is damaged.
 - b. If liquid has been spilled, or objects have fallen into the product.
 - c. If the product has been exposed to rain or water.
 - d. If the product does not operate normally by following the operating instructions. Adjust only those controls that are covered by the operating instructions as an improper adjustment of other controls may result in damage and will often require extensive work by a qualified technician to restore the product to its normal operation.
 - e. If the product has been dropped or damaged in any way.
 - f. When the product exhibits a distinct change in performance - this indicates a need for service.
19. Replacement Parts - When replacement parts are required, be sure the service technician has used replacement parts specified by the manufacturer or have the same characteristics as the original part. Unauthorized substitutions may result in fire, electric shock, or other hazards.
20. Safety Check - Upon completion of any service or repairs to this product, ask the service technician to perform safety checks to determine that the product is in proper operating condition.
21. Wall or ceiling Mounting - The product should be mounted to a wall or ceiling only as recommended by the manufacturer.
22. Heat - The product should be situated away from heat sources such as radiators. Heat registers, stoves, or other products (including amplifiers) that produce heat.

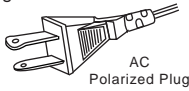

WARNING: Changes or modifications to this unit not expressly approved by the party responsible for compliance could void the user's authority to operate the equipment.

NOTE: This equipment has been tested and found to comply with the limits for a Class B digital device, pursuant to Part 15 of the FCC Rules. These limits are designed to provide reasonable protection against harmful interference in a residential installation. This equipment generates, uses, and can radiate radio frequency energy and, if not installed and used in accordance with the instructions, may cause harmful interference to radio communications. However, there is no guarantee that interference will not occur in a particular installation. If this equipment does cause harmful interference to radio or television reception, which can be determined by turning the equipment off and on, the user is encouraged to try to correct the interference by one or more of the following measures:

- Reorient or relocate the receiving antenna.
- Increase the separation between the equipment and receiver.
- Connect the equipment into a circuit different from that to which the receiver is connected.
- Consult the dealer or an experienced radio TV technician for help.

LIMITED MANUFACTURERS WARRANTY

Crosley Radio, Inc. warrants the product to be free from defects in material and workmanship under normal use for a period of one year from the original date of purchase. This warranty is not transferable. If the product is determined to be defective during the warranty period, the unit will be repaired or replaced at Crosley Radio's sole discretion. This warranty covers manufacturing defects and normal consumer use and does NOT cover damage or failure as a result of abuse, accident, alterations, misuse, neglect, abnormal wear and tear, inadequate maintenance, commercial or unreasonable use, damage caused by power surges, mishandling, accident, acts of God or attempted repair by an unauthorized service agent. Also not covered are cosmetic damages, cords and antennas.

Should this product fail to function in a satisfactory manner, it is best to first return it to the store or retailer where it was originally purchased. If additional service is still needed, the original purchaser must **FIRST** contact our offices to obtain an RA (Return Authorization) Number.

TO OBTAIN AN RA NUMBER
CALL: **1.888.CROSLEY**
(1.888.276.7539)

Send the unit prepaid to the address below in the original packaging (or reasonable substitute to prevent damage). Clearly mark your RA number on the outside packaging and include the original sales receipt (or a copy) indicating date of purchase, amount paid, and place of purchase. You must also include your full name, shipping address and daytime contact number. Please include a check or money order in the amount of \$19.95, made payable to Crosley Radio, to cover handling and return shipping charges. Returned products will not be shipped to PO Boxes. Crosley Radio will not be responsible for delays or unprocessed claims resulting from a purchaser's failure to provide any or all of the necessary information.

CROSLEY RADIO
ATTN: RETURNS DEPT
2001 PRODUCTION DRIVE
Louisville, KY 40299

For additional support: Crosley Radio Consumer Service Department
24 hours a day / 7 days a week
Telephone: 1.888.CROSLEY (1.888.276.7539)

*There are no express warranties except as listed above.
The purchaser's bill of sale is the only proof of warranty entitlement.*

This warranty gives the purchaser specified legal rights in addition to any rights which may vary from state to state.

In accordance with the "Moss-Magnuson Warranty Act" of July 10, 1975, this is termed a "limited warranty" which in no way compromises Crosley Radio's high standards of quality and workmanship.

Welcome

Thank you for purchasing the Crosley Revolution (CR6002A) Before operating this unit, please read this manual thoroughly and retain it for future reference.

About This Manual

Instructions in this manual describe the control functions of the CR6002A.

Included in the package:

- Crosley Revolution
- AC Power Adaptor
- 45 RPM Adaptor
- USB Cable
- Software CD
- Software Installation Guide

Table of Contents

Getting Started

Control Locators.....	4,5
Unpacking.....	6
Power Source.....	6
Headphones Jack Operation.....	6
Battery Operation.....	6

Basic Operation

Turntable	7
FM Transmitter	7
USB Output.....	8
Audio Output	8
45rpm Adapter	8

General

Transporting	9
Troubleshooting Guide	9
Warranty.....	10

Basic Operation

USB

Using the included software and cable, the USB connection allows you record your records onto your computer. Follow these instructions to use the USB.

- 1 Insert the enclosed software CD into your computer.
- 2 Connect the small end of the USB cable to the USB JACK on the back of the unit.
- 3 Follow the instructions on the computer screen to install the software. If the software does not load automatically, browse the CD and open the Read Me folder for further instructions.
- 4 Connect the other end to a USB port on your computer.
- 5 On your computer, open the Record Recording Software.
- 6 For instructions on operating the Record Recording Software, browse the software CD and open the Read Me folder.

Audio Output

Using the Audio Output allows you to listen to your Revolution on a home stereo, TV or other stereo source. The type of cable needed will vary depending on the input jack configuration of your external device. The output jack on your Revolution is a standard 3.5mm stereo output. See your local electronics store to purchase the correct cable for your needs. For more information on hooking up to an external device, see the owner's manual for the selected device.

Note: You can still listen to your unit when using the Audio Output feature.

Accessory: ADAPTER FOR 45 RPM

This adaptor allows you to play 45 RPM records.

- 1 Place the 45 RPM adapter over the spindle.
- 2 Gently place your 45 RPM record onto the turntable.
- 3 Follow the steps under turntable operation to play your record.

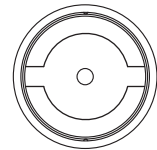

Control Locators

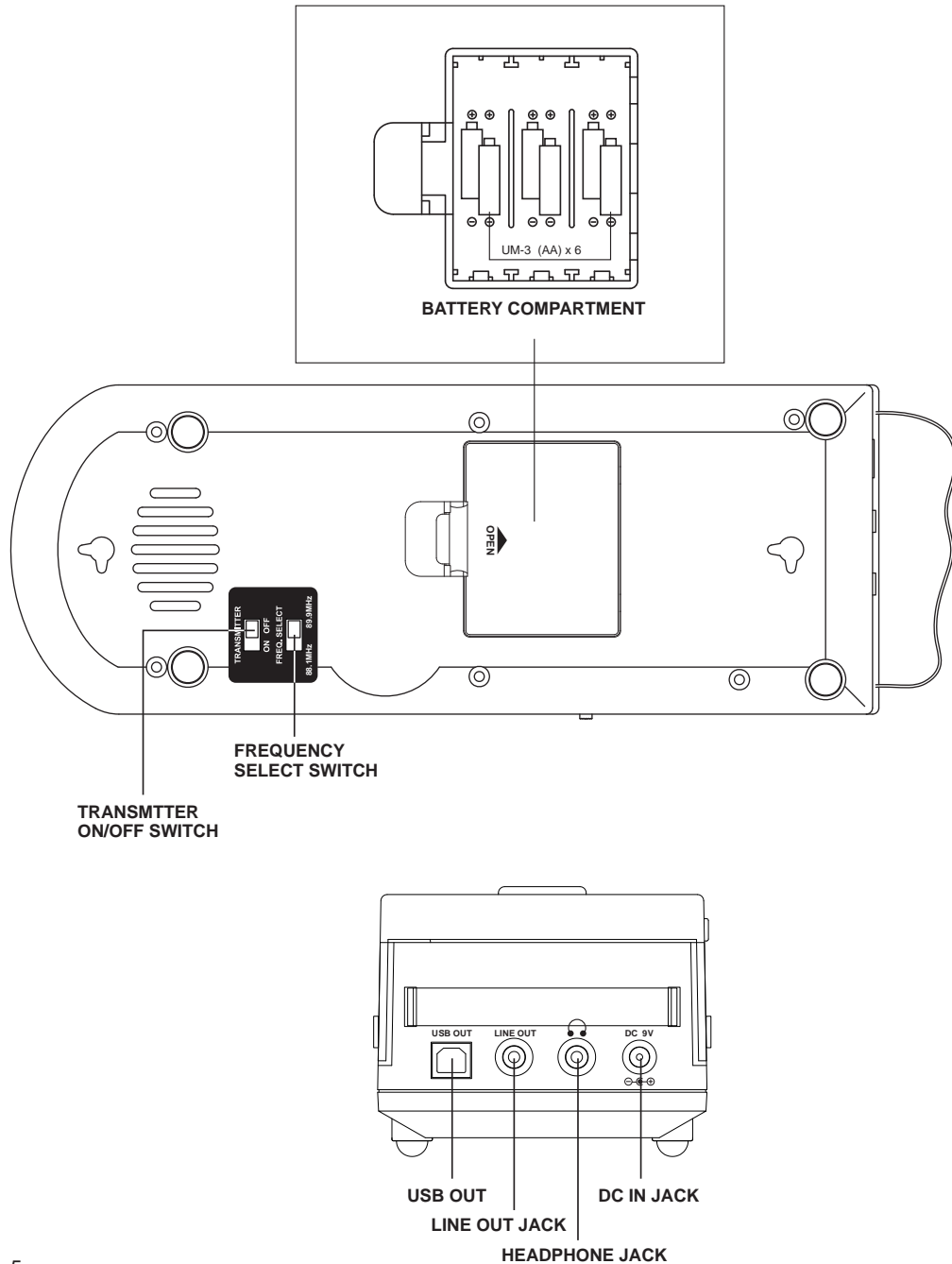

Getting Started

Unpacking

- 1 Remove plastic bag covering unit.
- 2 Remove AC ADAPTER from packing.
- 3 Remove tie from A/C ADAPTER.
- 4 Open lid and remove styrofoam shipping material from turntable.
- 5 Remove white protective needle cover by gently pulling towards the front of the unit.

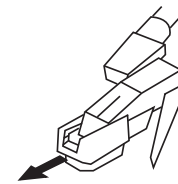

Power Source

- 1 Plug the AC ADAPTER into appropriate walloutlet.
- 2 Plug the small end of the adapter into the ADAPTER JACK on the back of the unit.

Headphones Jack operation

- 1 Connect headphones to the Headphone Jack.
- 2 Adjust volume to the desired listening level.
Note: When using headphones, sound from the unit will be turned off.

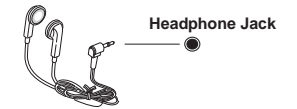

The sound from all speakers is cut off.

NOTE: Headphones not included with unit.

Battery Operation

1. The battery compartment is located at the bottom of the unit. Push the lever at the center of the door toward the rear of the unit, then lift the door free.
2. Six "AA" size batteries are required. Refer to the orientation diagram shown inside the battery compartment when installing.
3. Replace the battery cover.

IMPORTANT:

Remove all batteries from your unit if it will not be used for an extended period of time. Do not use rechargeable batteries and do not leave discharged batteries in the battery compartment.