

Monicor Electronic Corporation
RADIO MODEM SYSTEMS
M2000T & M2000S
Installation & Reference Manual

January 1999

Firmware Versions 2.8

Revision A

Monicor Electronic Corporation (c)
2964 N.W. 60 Street
Fort Lauderdale, Florida 33309 USA
Phone (954) 979-1907
Fax (954) 979-2611

MONICOR ELECTRONIC CORP.
FCC ID: GES4BAM2000S
EXHIBIT #: D

This manual and the firmware described in it are copyrighted by Monicor (c), with all rights reserved. Under the copyright laws, this manual or the built-in firmware of the Monicor equipment may not be copied, in whole or in part, with-out the written consent of Monicor.

<u>Table of Contents</u>	<u>Page</u>
INTRODUCTION	
Overview	1
FCC Information.	1
Warranty	2
Equipment Checkout.	2
Battery Powered equipment	2
INSTALLATION	
Hookup, Checkout, and Setup of Radio Modems	3
Connect to a Radio Modem	3
Control the Radio Modem.	4
Communicate Point to Point	5
Configure the Radio Modems.	6
Multiple Radio Modems	6
Status Indicator Lamps	7
Configuration Plug	7
INTERFACE OPERATION	
Link Operation	8
PAD Interface	8
Data Transfer Mode	8
PAD Command Mode	9
Flow Control	12
ADAP (Adaptive Dynamic Access Protocol)	14
Data Transfer Timing.	15
Hints to Speed Host Response Time	16
Pad Commands	17
Complete List of PAD Commands.	18
Baud	21
Communicate	22
Default	22
Facilities	23
Help	27
Identify	27
Profile	28
Reset	29
REStart.	29
SEt	30
Complete SET of PAD Parameters.	31
SEt Flow Control.	37
Status	39
Write	41
Multidrop Operation.	42
APPENDIX	
Service Signal List	46

INTRODUCTION

This manual covers installation and reference information for Monicor equipment, and will answer most questions regarding the use of Monicor equipment. The introduction contains descriptions and important general information. This installation section tells how to set up a basic system. The remaining sections contain detailed reference information for operation and application options. See the "Systems & Accessories" section for help in selecting system components.

OVERVIEW

Monicor radio modems provide RS-232 ASCII portable data communication over a single narrow-band UHF radio channel to eliminate data cables for up to several miles. Monicor systems consist of many different radio modem products for different applications. All of these use the same principles of operation which are covered in this manual. Each radio modem has a flexible communications port that can be configured for any type of equipment.

Two types of radio operation are available:

1. Link Operation
2. Multidrop Operation

Most installations use "Link" operation, which is the default.

Link Operation

Link Operation transfers information over the radio via variable length synchronous packets of data, with full error detection and correction. Information is buffered at each full duplex communication port. Flow control (either CTS/DTR or XON/XOFF) can be selected.

The minimum system (one network controller unit and one portable unit) acts like a wire link. Data input at one end is sent out the other. This means that a radio link can be installed into a system with **NO ADDED SOFTWARE**.

The network controller handles data transfer for one or more portable radios. A simple "circuit switch" command issued by the host switches the current circuit of the controller interface. Each circuit (data path between a terminal and the host) is fully buffered so that the radios can transfer data automatically while the host switches the controller port to one circuit at a time. It simply sends and receives data to access the buffers of the current circuit.

As many as 99 remote radios may operate with a single network controller on a single radio channel. The host can check the status of a circuit to sense if there is any activity by any portable terminal. Only one network controller may operate at any one time on a single radio frequency. Multiple network controllers may be used at any given time, providing that they are all on separate frequencies or have an adequate separation distance.

Each radio modem is configured independently. Configuration parameters include Baud rate settings, interface profile (edit, standard or transparent), the portable Link Number and the controller Link Quota, the flow control, etc.

Most installations use "Link" operation, which is the default. However, most installations require the "transparent" profile, and this must be selected and "written" into each radio along with the link number or quota or "dynamic mode" (see "configuring the radio").

Multidrop Operation

Multidrop Operation is selected when standard multidrop software is being used. The radio modems are a transparent addition to the wired network and operate "Plug-and-Play". Multidrop requires the terminals and/or computers to supply all of the radio protocol.

FCC INFORMATION

The Monicor M2000T and M2000S and its components comply with Federal Communications Commission (FCC) requirements which regulate Business Radio Service and other services within the 450 to 470 MHz range.

The Monicor system is specifically designed to operate in the 12.5 KHz UHF splinter channels as outlined in Part 90.217 of the FCC Rules and Regulations document 47 CFR.

The user must know and comply with all applicable parts of the FCC Rules and Regulations. Rules applicable to each service, covered in document 47 CFR, may be ordered from:

Superintendent of Documents
Government Printing Office
Washington, D. C. 20042

A valid station license is required before operating the radio modems. It is the user's responsibility to apply for and obtain an FCC radio license.

WARRANTY

This equipment is warranted to be free from defects in both materials and workmanship. Should any part of this equipment be defective, (excluding holsters, external antenna's, cables and general accessories) it will be repaired or replaced, at our option, free of charge (except incoming shipping charges) for a period of one year (365 days) from the date of original purchase. No charge will be made for parts or labor during this period. Proof of purchase (such as a copy of bill of sale or canceled check) must be submitted to obtain the benefits of this warranty. *Please* obtain a RETURN MATERIAL AUTHORIZATION for any material to be sent back to the factory.

This warranty is void if:

- (a) the equipment has been damaged by negligence, accident or mishandling, or has not been operated in accordance with the procedures described in the operating instructions; or
- (b) the equipment has been altered or repaired by other than Monicor Electronic Corporation, or adaptations or accessories other than on Monicor's approved price list have been made or attached to the equipment which, in the determination of Monicor shall have affected the performance, safety, or reliability of the equipment.

NO OTHER WARRANTY EXPRESSED OR IMPLIED, INCLUDING MERCHANTABILITY, APPLIES TO THE EQUIPMENT, NOR IS ANY PERSON OR COMPANY AUTHORIZED TO ASSUME ANY OTHER WARRANTY. MONICOR DOES NOT ASSUME ANY RESPONSIBILITY FOR ANY CONSEQUENTIAL DAMAGES OCCASIONED BY THE EQUIPMENT, OR INCONVENIENCE OR INTERRUPTION IN OPERATION.

In case of unsatisfactory operation, the equipment should be sent directly (or through a factory authorized dealer) to Monicor Electronic Corporation with a description of the problem. Please do not include personal material with the returned equipment as Monicor does not accept responsibility for these items.

Extended Warranty

Monicor's extended service agreement provides warranty coverage on a yearly basis. It provides the same coverage as the original 1 year factory warranty, but does not include batteries, holster, external antenna's or cables. Warranty periods must remain continuous (no gaps between periods). If a warranty lapses, and a new warranty is desired, the unit may be subject to rechecking and restoring to a warranty state.

EQUIPMENT CHECKOUT

Battery powered equipment

The M2000T operate with internal 7.5 volt Nickel-Cadmium batteries. **Important: Nickel Cadmium batteries must be charged before use.** Be certain the power switch located on the top of the M2000T is in the "OFF" position before charging. Charge the batteries with the AC power adapter provided with the unit for at least fourteen (14) hours before normal operation. Units shipped from the factory may not contain a full charge.

The chargers should be disconnected from the M20T when not powered by 120 VAC to avoid discharge of the battery.

Do not use any AC power adapter other than those provided by Monicor for each specific model to avoid possible damage.

Once fully charged, the M2000T should operate for an 8 hour period or longer, depending on activity. (See NOTE). The M2000T should be turned off when not in use.

A separate AC power adapter is available for charging spare battery packs directly. To charge a separate spare battery pack, connect the keyed rectangular connector on the adapter to the mating battery receptacle and charge for at least 14 hours.

Battery Charger Connector:
Center Pin - Positive
Outside Pin - Negative

Always use the correct Monicor battery charger: P/N 10000-392-006 (marked 9v, 100ma) for the M2000T.

M2000S

The M2000S is a light-weight single piece radio module that attaches directly to the back of the Mars Electronics MEQ series of Portable Data Terminals. Power is supplied via the RJ-45 pin connector. To configure the M2000S, a configuration cable (Monicor P/N 10001-540-021) is recommended, which supplies regulated 8.0 volt power to the M2000S via a wall mount supply and voltage regulator.

Mars, and the Mars Electronics International Device are registered marks. MEQ is a trademark of Mars, Inc. Information is subject to change without notice.

INSTALLATION

This section tells how to set up a basic system.

HOOKUP, CHECKOUT, AND SETUP OF RADIO MODEMS

This section describes how to:

- Connect a radio modem to a Computer.
- Control the radio modem.
- Communicate through a second radio.
- Configure the radio modems.

IMPORTANT

The M2000T operates with internal 7.5 volt NiCd batteries. These *must* be charged before use. The power switch should be "OFF" before charging. Charge each unit for at least fourteen (14) hours with the proper AC power adapter. **DO NOT** use any AC power adapter other than those provided by Monicor for each specific model to avoid possible damage. (See "Unpacking Instructions").

Connect to a Radio Modem.

The connection to the equipment is made via a female 9 pin D-shell RS-232 connector or an RJ-45 connector (for the M2000S). This connector is located on the side of the M2000T. The RJ-45 connector is located on the bottom side of the M2000S.

To configure and check-out an M2000S using a computer, use the Monicor configuration cable.

If a Monicor supplied coil cable came with your radio modems, simply connect the DB-9 male (or RJ-45) connector to the radio, and the DB-9 or DB-25 connector to the COMM 1 port on your computer.

Custom cables

If you need to build a customized cable the following are the pin definitions for the radio modems. The term "DTE" stands for Data Terminal Equipment, and refers to the signal at the terminal. For example, DTE Rx/D means the received signal line for the terminal, which would be the transmit signal for the radio modem.

All radio modems are defined to be DCE's (Data Communication Equipment).

Pin Description for Radio DB-9 Connector

PIN	Description	Signal
* 1	DTE power option	
2	DTE Received Data (output)	(Rx/D)
3	DTE Transmitted Data (input)	(Tx/D)
4	DTE Ready (input)	(DTR)
5	Ground/Signal Common	(GND)
6	DCE Ready (output)	(DSR)
** 7	No Connection (SEND Lamp)	
8	DTE CTS (output)	(CTS)
*** 9	Reserved (Monicor Test Pin output, provides de-emphasized audio output for site surveys)	

* Optional power output on M2000T is switched from battery, intended for low-power external device only. **CAUTION!** Not regulated or fused.

*** Do not connect any wire. This pin can be connected to an external audio amplifier to detect on channel interference and other test data.

Data output Pin 2 from the radio modem must be connected to the data input of the terminal. Likewise, data input to Pin 3 of the radio modem must be connected to the data output. If the host or terminal equipment appear as a DCE, use a "null-modem" connector or alter the connector wiring.

Pin Description for Radio RJ-45 Connector

PIN	Description	Signal
1	Power	
2	DTE Received Data (output)	(Rx/D)
3	Ground/Signal Common	(GND)
4	DTE Ready (input)	(DTR)
5	DTE Transmitted Data (input)	(Tx/D)
6	DCE Ready (output)	(DSR)
7	DTE CTS (output)	(CTS)
*** 8	Reserved (Monicor Test Pin output, provides de-emphasized audio output for site surveys)	

*** Do not connect any wire. This pin can be connected to an external audio amplifier to detect on channel interference and other test data.

Data Flow Control Signal Pins

The following signals are provided for hardware flow control and other control functions:

Pin 4	DTE Ready	(DTR)	an input
Pin 6	DCE Ready	(DSR)	an output
Pin 8	DTE CTS	(CTS)	an output

DCE Ready is "ON" when power is on, and is zero volts otherwise.

The DTR signal is used by the terminal to control the flow of received data from the radio modem. The terminal sets DTR (pin 4) ON to indicate to the radio modem that the terminal is ready for more data.

The CTS signal is used to control the transmitted data from the terminal. When CTS is ON, the radio modem is ready for more transmitted data.

IMPORTANT

If the host or remote equipment lacks a DTR signal, Software flow control MUST be used.

Control the Radio Modem

This section contains a procedure for establishing communications between a radio modem and a terminal. The terminal can be a PC running Monicor's HOST.COM program supplied on the demonstration diskette, or any standard ASCII terminal.

Default Configuration

The radio uses many parameters to choose from many different options for operation. The operating configuration is kept in RAM and is lost when the radio is powered off.

Radios are normally shipped from the factory with the Initial Configuration (EEROM, for power-up) set to the current factory default configuration (from firmware PROM). The EEROM is only changed by the "Write" commands.

The factory default configuration parameters are:

Profile	Edit
Baud:	9600 baud, no parity, 8 bits per character, and one stop bit (9600,N,8,1)
Facilities Link Dynamic Mode:	off (0)
Facilities Link Number:	one (1)
Facilities Link Quota:	one (1)
Facilities Link Size:	5 (32 character packet).
Facilities Link Multidrop:	Disabled
Flow Control:	1 (XON/XOFF)

Load the program HOST.COM from the diskette to a subdirectory in your computer. Connect the cable from the radio modem to serial COMM PORT 1. Execute the program by typing "HOST".

The program announcement contains a short help menu (help documentation supplied on the disk). Press the "F7" and "F9" function keys to turn off flow control checking. Two acknowledgments appear.

Connect the antenna. Turn on the radio modem. The radio modem will greet you with a sign-on message, a command list, and a prompt "***" character. After a short period of time, several short messages will appear, called PAD SERVICE SIGNALS. The modem is now in a local communications mode, called PAD COMMAND MODE.

If the radio modem has indicator lamps, the red and green will both turn on when power is switched on. They will stay illuminated for about 2 seconds while the unit performs a power on test. Both lamps will turn off, then the green on will start a slow blinking. If the modem has only one lamp (green), it will go through the same sequence.

Communicate Point to Point

If the red lamp remains on, the battery is low, and requires charging. If no lamp's glow, then the battery may be completely discharged, and the unit should be charged.

Verify that communication has been established by verifying the default configuration parameters.

Type a "p" for profile, followed by a <CR> (return). The response will indicate "Editing".

Verify other parameters and familiarize yourself with the menu. *Don't type the "w" command yet. This will be used to "write" new profiles into your radio modem.*

Type an "h <CR>" for help

Type an "f <CR>" for facilities.

Type a "b <CR>" for baud.

Type "SE <CR>" to verify flow control = 1

Type an "s <CR>" for status.

Adding a second radio

Since there is only one radio connected and turned on, the status will indicate that the opposite circuit is not on.

Leave the first radio on, disconnect the DB-9 connector from the radio, and connect it to the second radio.

Turn on the second radio modem.

Follow the same procedure as before to verify communications.

Verify that communication has been automatically established between the two radios by:

1. Observing that the green Lamp has stopped blinking.
2. Typing the "s" status command and verifying that the status now indicates two 0's (zero's) are under the heading of the Send and Receive queue.

The radio modems are communicating with the PC.

This section contains a procedure for testing basic operation of a network controller and a remote radio modem. This procedure requires a combination of the following equipment, interconnecting cables, and two terminals.

Remote Type Network Controller Type

In general, any remote unit will communicate with any network controller provided that the radio speed matches, and the radios are on the same channel.

This test can be performed with two terminals (preferably) but can be also tested with a single terminal, using a loop-back technique.

Testing with Two Terminals

Connect the radios to the terminals as in the previous section. Establish communications by having the prompt character "*" appear on both terminals.

Type C <CR> (Communicate) on one terminal, then type C <CR> on the other terminal. A message will be returned, "01 <CR> COM <CR>" indicating that the corresponding unit is now in the "data transfer mode", and is "communicating" via circuit 01.

Messages typed on one terminal will be transmitted to the other after a <CR> is typed. The green Lamp will blink briefly on the unit originating the message.

Type Control P (^P) on either terminal, and a mode change message, "PAD Commands:" will appear on that terminal. Repeat this entry for the other terminal. Both units have escaped from the data-transfer, and will now accept local commands from the terminals, such as H (Help) above.

If the remote or the network controller has been set to the TRANSPARENT profile, exiting from the data transfer mode is done with the following sequence:

<1 sec idle> + + + <1 sec idle>.

This will force the radio modem to escape from the data transfer mode and enter the PAD command mode. Pad service signals, like the Command Menu, will be displayed.

Set the profile back to Edit by typing P (Profile), E (Edit), then <CR>.

Testing with One Terminal

This test uses one terminal to originate a message through one radio. The receiving radio will deliver the data out its RS-232 connector, and pass it back to the originating radio with a "loop-back" connector.

This loop back connector can be easily constructed, or purchased from Monicor. To construct the connector, make the following connections on a male DB-9 connector:

Loop-Back Connector
Connect Pin 2 to Pin 3
Connect Pin 4 to Pin 8

With both radios turned on, connect one radio to a PC using HOST.COM. Place the radio in the data transfer mode by typing C <CR> from the keyboard. Remove the DB-9 cable, and replace it with the loop-back connector. Connect the PC to the other radio, and place that radio in data transfer. Type a message, then <CR>. The message will be echoed back on the next line.

Configure the Radio Modems

Establish a communications session with a radio and a PC, as in the preceding example.

The radio modems can be configured two ways:

1. Temporarily (active configuration)
2. Permanently (power-up configuration)

Temporary Configuration

With the radio modem at the "*" prompt, change a parameter, then note that the change disappears when the radio is turned off, then back on.

Type "p" for profile, then <CR>. The result should be "Editing". The command, as all others, take parameters. Type "p", then "t", one of the profile options. Transparent will be echoed back. Then <CR>.

Type a "p" again to see that the profile has been changed to transparent.

Now, turn the radio OFF, then ON again. Type a "p" to verify that "Editing" is the current, power-on profile.

Permanent Configuration

Repeat the above command to change the profile to transparent. This time make the change permanent by using the "w" (Write) command. Type "w" then "p" (for profile), then <CR>. The modem asks if you really want to do this; type "y" (for yes) then <CR>.

Type "p" <CR> to verify the profile has been changed.

Now, turn the radio OFF, then ON again. When the radio is turned on again, the modem will automatically start in the data transfer mode (no menu will appear).

Press the "F7" and "F9" function keys on the PC to disable flow control checking. Then wait one second, then type three plus signs "+++". After another second has passed, the modem will respond with a message "PAD COMMANDS" and a prompt.

Type a "p", to verify the profile is in transparent.

MULTIPLE REMOTE MODEMS

The network controller will communicate with up to 99 remote radio modems in Link Operation. The Link Quota is set to the actual number of remote radio modems desired in the system. The remote units must be numbered sequentially (Link Number) from the first up to the highest number.

Remote radios and network controllers are not distinguished in multidrop operation. The maximum number of multidrop radios is determined only by the user's protocol.

Caution

Errors will occur in Link Operation if two remote radio modems have the same link number. Be sure each remote is assigned a different (unique) number.

To change the Link Number or Link Quota, use the Facilities command. Make the change the power-on default by using the Write command. (See the "PAD Commands" section).

STATUS INDICATOR LAMPS

A red and a green lamp indicate the status of the radio modem at power-on and during operation.

Both lamp's illuminate at power-on to indicate self-testing, and turn off upon successful completion of the power-on test (about three seconds).

However, if the battery voltage is low at power-on, only the red lamp will glow, and the modem will not function until the battery is charged.

If the battery voltage becomes low during operation, the red lamp will begin blinking, indicating only several more minutes of operation remain. After continued operation, when the battery fails to supply the minimum operational voltage, the red lamp will illuminate steadily. The modem will not function, and the transmitter will be forced off.

The radio modems initiate automatic radio communications after successful power-on. Radio link Restart and Reset operations are indicated by a blinking green lamp until all circuits have been initialized.

A blinking green indicates data or reset conditions in the outgoing or incoming link buffers, link delivery pending to the remote radio modem ('s) or local terminal. The green lamp will always blink at least once when a packet or more of data is transmitted from the local terminal.

When using Multidrop operation, the green lamp indicates actual transmission is taking place. This is also true for Link Operation only if the Facilities Green parameter is enabled.

Metal enclosed units (ME) have a provision at the RS-232 connector to attach an external green LED to monitor the SEND function. The LED must be a low power (2 milliamp) LED, and is connected between pin 7 and ground (pin 5).

CONFIGURATION PLUG

The default configuration plug is used to set all parameters to the factory default values for the installed firmware version (2.0 and higher). The "permanent" power-up configuration is not affected.

Use a male connector with the following two pairs of pins connected as a 'default configuration' plug:

	TxD to DSR	DTR to CTS
DB-9:	3 to 6	4 to 8
DB-25:	2 to 6	20 to 5

Plug the connector into the radio or into a standard cable connected to the radio.

Turn on the radio while watching the green lamp. The lamp will be on for about 3 seconds and then start flickering. The flickering will last for about 5 seconds.

The default-configuration plug must be removed during this 5 second period in order to force the radio to the default configuration. The green lamp may start flashing about twice a second, but that is easily distinguished from the very rapid flickering.

Connect the terminal to the radio after the flickering has stopped.

The radio now has all parameters set to the factory default values, and the radio issues the "configuration overrule" signal immediately after the flickering has stopped, but this will not show up on the terminal since it is not connected at that moment.

The power-up configuration can be activated for any of the three groups of parameters (baud, facilities, profile) by executing the command(s) Baud Initial, Facilities Initial, or Profile Initial.

Execute the appropriate command(s) in order to check or modify the power-up configuration. (Modify with "Write").

Note

When newer firmware is installed, the factory default configuration should be modified directly and written for all three areas instead of using any old "Initial" values. (See "Firmware Upgrade Procedures").

INTERFACE OPERATION

This section describes each type of operation in detail, and the commands for setup. Most installations use "Link" operation for communication. The PAD commands are for control and configuration of Link operation with the PAD interface, and mostly do not apply to "Multidrop" operation.

LINK OPERATION

Link operation provides fully error corrected permanent virtual circuits, and disables multidrop operation.

PAD Interface

The PAD (Packet Assembly/Disassembly) interface provides a simple network connection for terminals or hosts using asynchronous RS-232 interfaces. The *assembly* is the process of grouping one or more characters of user data into a packet for error free transfer through a network.

The PAD interface is always in one of two modes: the "PAD Command Mode" or the Data Transfer Mode".

In the data transfer mode, data transmitted from a terminal or host goes to the radio and is forwarded to the corresponding remote terminal (or host).

In the command mode, terminal output is intercepted and interpreted as commands by the attached radio, and the terminal receives radio generated responses ("PAD Service Signals") instead of remote transmitted data. The terminal controls the active mode by sending certain commands.

Data Transfer Mode

In the data transfer mode, terminal output is collected in an *edit buffer* and assembled into packets when a forwarding condition is met. The packets are then sent to the remote terminal. Incoming packets from remote terminals are disassembled into the original characters and transferred to the terminal as received data.

An *edit buffer* is a reserved space for each circuit where transmit data is held until a forwarding condition occurs (see figure 1).

A *send queue* is a reserved space for each circuit that can hold up to two packets for radio transmission. After a forwarding condition occurs, the send queue will grab data from the edit buffer as soon as there is an empty packet slot (less than two packets).

The amount grabbed will be as much as can be forwarded (for which one or more forwarding conditions apply), but no more than the *maximum packet size*, which depends on the *Link Size* parameter. (The edit buffer is always larger than the maximum packet size.)

This creates a new packet, which contains one or more characters of user data, and increases the free space in the edit buffer.

Packets received from another radio are placed in the receive queue. This is an area of memory reserved for each circuit and holds up to two packets pending delivery to the local terminal.

The terminal may force the radio modem to switch from the data transfer mode to the PAD command mode (escape from data transfer). The options for escape from the data transfer mode depend on several PAD parameters. One option allows ^P to be used as an escape command character. Another option allows use of the following sequence:

<1 sec idle> + + + <1 sec idle>.

With the ^P option, if two ^P's are transmitted to the radio modem, the second brings the PAD interface right back to the data transfer mode and is put into the edit buffer.

Escape from data transfer is a forwarding condition for the contents of the Edit Buffer of the current circuit. The circuit switch command also constitutes a forwarding condition.

When a radio modem escapes from the data transfer mode to the PAD command mode, the opposite end of the circuit does not receive explicit indication. But since the command mode prevents received data delivery, the other end might see data backup after enough packets are sent, until delivery is resumed.

PAD Command Mode

In the PAD command mode, all data from the terminal is interpreted by the local modem as PAD commands, and all data from the modem to the terminal are local modem-generated responses (service signals). No data is exchanged with the circuit queues, although the queues can still exchange packets across the link. Service signals are generated in all profiles while in the PAD command mode. Depending on the profile, service signals may also be generated in the data transfer mode in response to modem or remotely generated events or in response to terminal issued status subcommands on circuit zero (see figure 2).

The "+" character (defined by the *PChr* parameter) is equivalent to <CR> in the PAD command mode.

All unused control characters are echoed as BEL and ignored.

When a command or parameter is not acceptable, only the first unacceptable character is echoed. Each unacceptable character is echoed as the BEL character. When a command cannot be executed, "ERR" is returned, sometimes followed by additional information about the problem.

A command may be canceled at any point during entry before entering <CR> by entering ^X or (enough) DEL characters. A new prompt is returned.

Every command response ends with a "<CRLF>" prompt, except for communicate, circuit-switch, and editing commands.

Command Mode Editing

In the command mode, limited command-line editing is supported. This also applies to the data transfer mode only if "EDit" is enabled.

For some of the following details, note that the radio distinguishes certain characters delivered to the terminal as printing characters, and keeps track of the "current column" of the terminal display (assuming there is one) according to the delivery sequence of printing, non-printing, and certain control characters. Printing characters are those from 32 to 255, except for 127 (DEL). The BS (8) decreases the column by 1, and the CR (13) resets the column count to zero (the left). The radio also counts LF's delivered (for paging purposes).

In the command mode, and on circuit zero, deleting a character from the buffer when an error has been detected will also cause any other characters following and including the one causing the error to be deleted. Note that when echo is on, only the first character upon entering an error is echoed, and each "error" character is echoed as a BEL character.

In the command mode, and on circuit zero, when echo is on, the radio will echo entire words as soon as entry is unambiguous. For very long commands using a high degree of abbreviation, it is possible that the echoed output will encounter the 255 character limit for command-echo. The unechoed command can still be valid, but the BEL cannot indicate an error after the limit is reached.

The line-delete editing command may display a response. This will depend on the value of parameter number 19 ("TYpe"). If "TYpe" = 0 (no editing signals), then no response is displayed. If "TYpe" = 1 (Printing Terminals), or any other value except 2 (Display Terminals), then the sequence "XXX" is displayed, followed by a CRLF.

If "TYpe" = 2 (Display Terminals), then one of the following responses will apply. If local echo is off for the current mode, then nothing is displayed. Otherwise (echo on), if the buffer is empty, then a BEL is delivered (beep). Otherwise (not empty), if in the command mode or circuit zero, the radio sends the number of rubout sequences required to return the calculated column to the far left, except if the column is already there, the radio sends a space for each character in the buffer, followed by a CRLF. Otherwise (data transfer mode and not circuit zero), if the calculated column is less than the amount of data in the buffer, the "XXX" + CRLF sequence is issued. Otherwise, a rubout sequence is sent for each character in the buffer (by simple count).

The character-delete editing command may also display a response. This will also depend on the value of parameter number 19 ("TYpe"). If "TYpe" = 0, no response is displayed. If "TYpe" = 2 or 8, then no response is displayed if the character is not echoable. Otherwise (is echoable), if the character was a graphic character then the rubout sequence is sent for "TYpe" = 2, and the BS character is sent for "TYpe" = 8. Otherwise (not graphic), if the character is a CR or LF, then the buffer is displayed ("repeated"). Otherwise (neither graphic or CR or LF), nothing is displayed. If "TYpe" = 1, then "\" is sent to the terminal. If "TYpe" is none of the above values, then the character corresponding to the value of "TYpe" is sent to the terminal.

The rubout sequence normally consists of the three characters BS SP BS. However, if FOLD is not zero and is even, and the calculated column is equivalent to the value of FOLD, then SP is sent instead, since it is assumed the cursor is at the right edge in the same column as the previous character.

Note that the radio will assume the terminal cursor moves backwards for any "TYpe" of response, so "FOLD"ing might not fold when expected if a line has characters deleted and the "TYpe" response is a printing character.

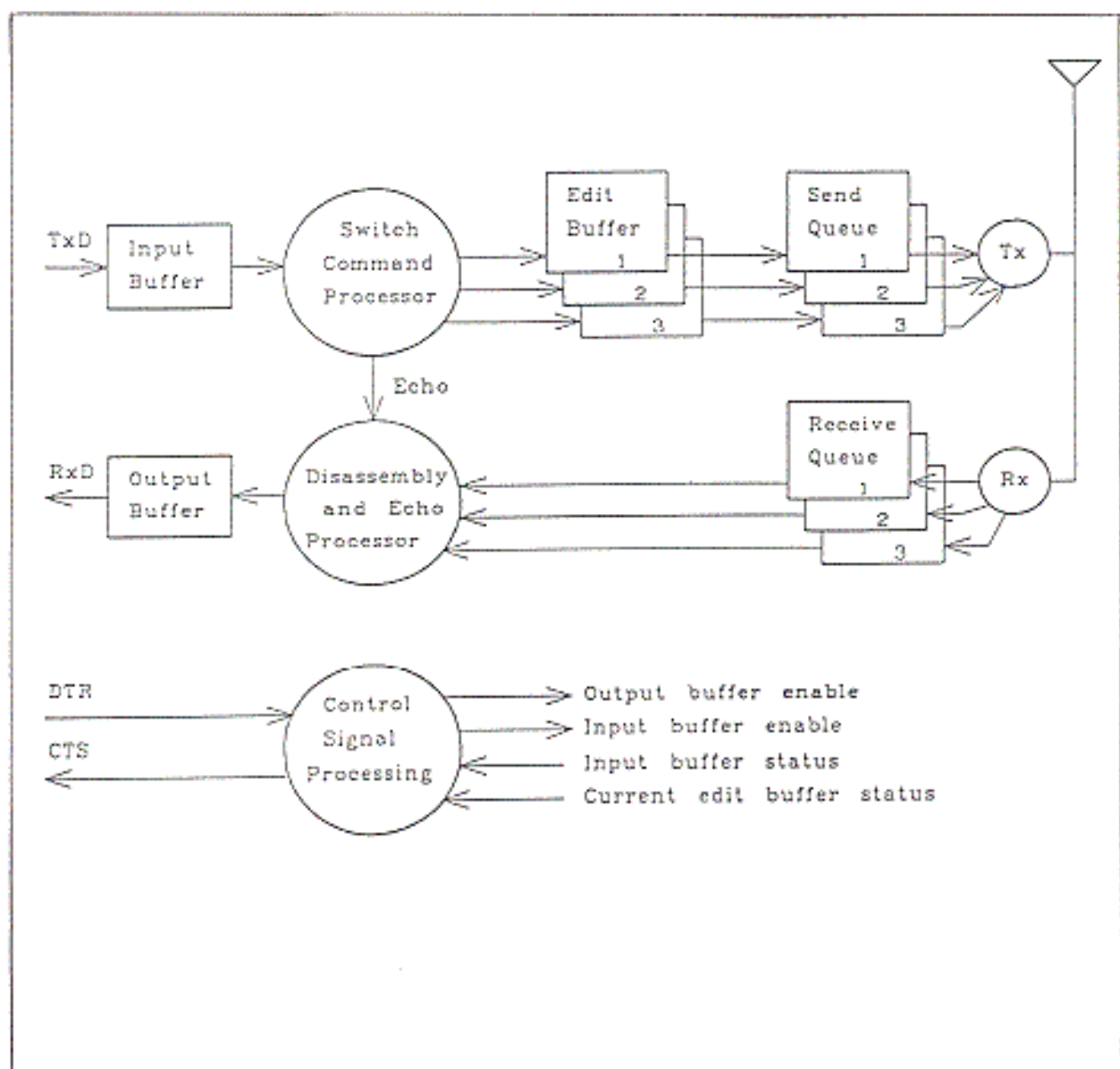

Figure 1
Controller Radio in Link Operation Data-Transfer Mode with a Quota of 3 Circuits

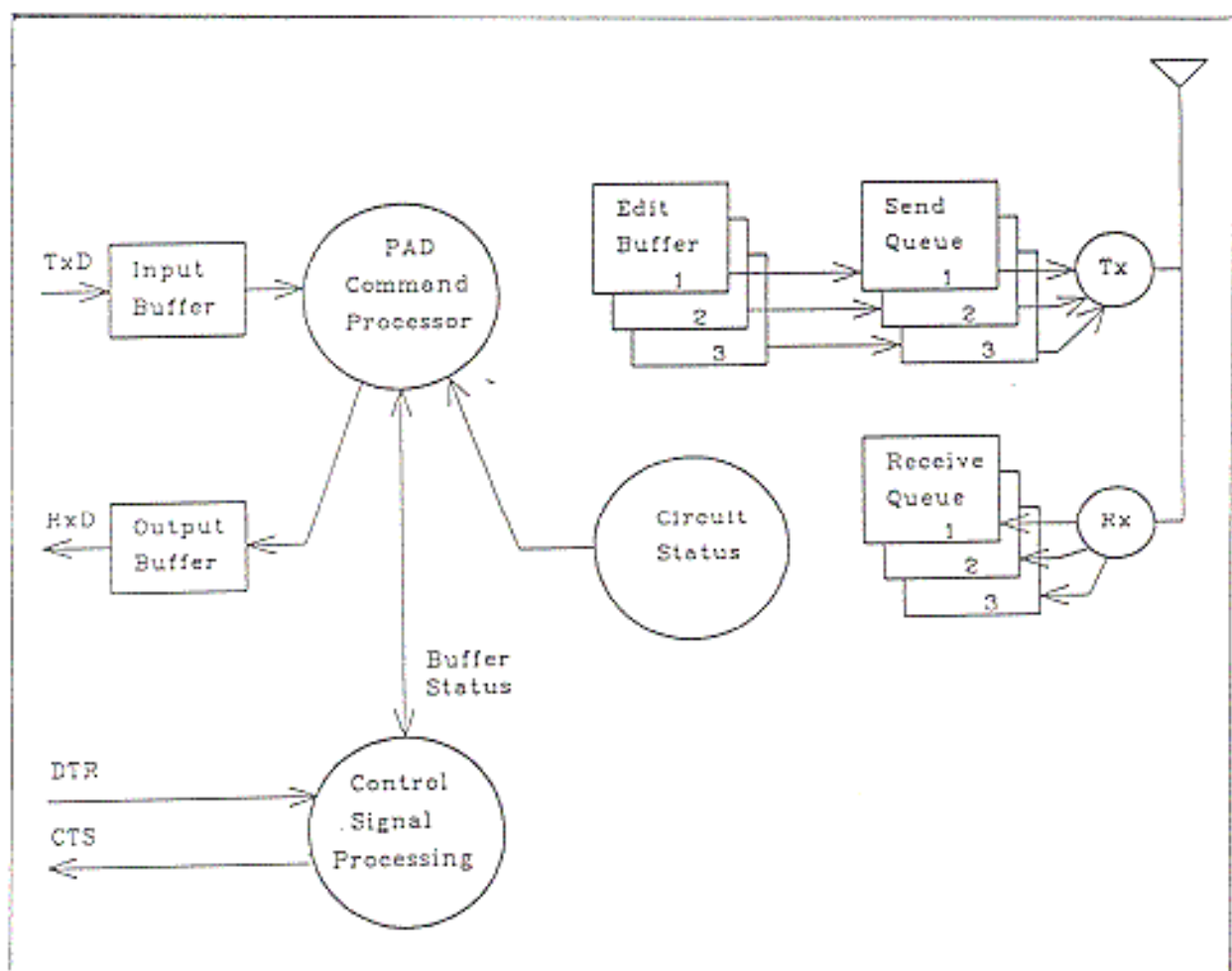

Figure 2
Radio in Command Mode (or on circuit zero in Link Operation Data-Transfer Mode), Quota = 3

Flow Control

Flow control is used by each device on the RS-232 link to regulate the data being sent from the device at the other side of the RS-232 link. The terminal may exercise flow control of received data at any time as desired. Flow control is exerted by the modem according to the following two conditions.

In the PAD command mode, transmitted data is shut off only when more than 191 characters are received, but not yet processed.

The radio continuously processes (removes) data from the input buffer, but sometimes the processing is slower than the maximum RS-232 transmit rate, especially at the higher baud rates.

Transmitted data is shut off in the data transfer mode when either the edit buffer for the circuit is nearly full (about 20 characters before overflow, depending on Facilities Protocol Full), the circuit is down, or the circuit is busy resetting. In any of these data transfer cases, the terminal may (and should) ignore the OFF condition to send commands (circuit switch and PAD escape), although a 255 character limit applies in all cases of unprocessed transmitted data (the input buffer size).

Two primary methods of flow control with the radio modems are software and hardware flow control.

With software flow control, the characters XON and XOFF (^Q and ^S) are inserted in the outgoing data stream to indicate control of the incoming data stream. The modem interprets these characters to start or stop the flow of received data to the terminal and deletes them from both the forwarded data stream and the echoed data. The terminal should perform a similar function for transmitted data by sensing XON and XOFF in the received data stream. XON and XOFF can be transmitted regardless of whether flow control from the modem for TxD is on or off.

Hardware flow control utilizes the control signals DTR (pin 4) and CTS (pin 8) within the DB-9 connectors. The DTR signal controls the modem's output of received data, and CTS is intended to control the terminal's output of transmitted data.

Using either software or hardware flow control, OFF means flow is to be discontinued, and ON means flow can be resumed (in the applicable direction).

If input buffer overrun is detected in the command mode or with service signals enabled, the following service signal is issued:

<prefix> ERR: TxD Buffer Overflow <suffix>

Multi-Circuit Flow Control

The terminals must manage flow control in an efficient manner to avoid losing data. This applies for either hardware or software flow control options.

For any two devices exchanging data through a RS-232 connection, flow control allows each device to control its reception of data by causing the other device to stop or continue sending the data. In the System 200, flow control must be implemented between the host and network controller and also between the terminal and the remote radio modem.

Flow control prevents any loss of data under conditions which would otherwise require infinitely large buffers. Some of these conditions are:

A terminal has limited receiving capacity, such as a printer with a fixed capacity, or a computer having to wait for disk access, or a person wanting to freeze a display until finished with it.

A terminal's capability to transmit data exceeds the radio link capacity, such as when transmitting much data at a high baud rate, when a radio is temporarily out of range, or when many circuits are active at the same time, diluting the radio transfer of data for the circuit of interest.

The radio-modem is temporarily busy and cannot transfer data, such as while resetting a circuit, or while a long sequence of commands are being sent faster than they can be executed.

A circuit is "down" and the network cannot transfer data through it, such as when one of the radios or terminals is off or disconnected.

A terminal stops received data, that data being command responses or the echo of transmitted data, while continuing to send the commands or transmitted data. The halting of the responses or the echo soon prevents further processing of the transmitted data, which in turn requires that the transmitted data be shut off by the radio-modem.

Certain commands are recognized in the data-transfer mode. Since these commands do not constitute data, they may be sent even when flow control of transmitted data (TxD) is off. The terminal should be programmed to ignore this flow control condition while transmitting commands to switch between circuits or escape from data transfer mode.

When a terminal intends to send data to a circuit and switches to that circuit, it should wait for the echoed circuit switch characters and determine the subsequent flow control indication before starting to send any data. Flow control will be determined for that circuit once the switch characters are echoed. This guarantees that the flow control now applies to the new circuit.

Under normal data-transfer conditions, the radio modem will signal the terminal to switch off the transmitted data soon enough that at least twenty more characters can be sent without being discarded due to buffer overflow. (This depends on the value of Facilities Protocol Full).

When software flow control is chosen, the signal to turn off data in one direction is the transfer of the XOFF character (DC3, or ^S) in the opposite direction, and the XON character (DC1 or ^Q) signals to continue data. When hardware flow control is chosen, the modem uses the CTS signal and the terminal uses the DTR signal to signal flow off or on. The "on" state is positive voltage, and the "off" state is negative voltage.

Typical Problems:

With the Editing (or Standard) profile, software flow control is the default (XON/XOFF). For a system of one remote radio modem and one network controller, with the network controller turned on while the remote remains off, the network controller will issue an XOFF when switched to the data transfer mode. If your terminal or communications program is checking for XON/XOFF and does not provide an XOFF indication and the means to bypass flow control, then the keyboard will become inactive. This condition will persist until the remote is turned on, or an XON is entered and a ^P or other escape is made to the "PAD Commands" mode. Note that most terminals will interpret the XON key (^Q) locally when the keyboard is disabled and reactivate it.

A similar situation will occur when operating in the Transparent profile. This case is more difficult to recognize, since no pad service signals are output from the modem during power-on as is the case in the Editing or Standard profile. The modem immediately goes into the data transfer mode and most terminals cannot be easily set to ignore a CTS-off signal. The CTS-off signal to the terminal must first be bypassed in order for the terminal to send characters, then an escape to the "PAD Commands" mode is made with the sequence

<1 sec delay, + + +, 1 sec delay>.

The flow-control parameter sets both the Rflo parameter and the Tflo parameter. Rflo is set to the value modulo 4, and Tflo is set to the actual value specified. Flow-control will indicate 'Mixed' if the Rflo and Tflo values do not correspond in this way. Where Rflo = 0 and Tflo = 0 or 4, a special case of half-duplex is specified.

An option can uncouple the flow-control of transmitted data from the status of the current circuit and edit-buffer (packet-assembly buffer) while on a valid circuit. (There is no edit-buffer for invalid circuits, and the flow-control is already uncoupled in the command mode and on circuit zero.) The option is obtained by adding four to the flow-control value.

With "Flow-control" set to 4 and up, control is disassociated from the edit buffer. The flow control actually consists of two standard PAD parameters (# 5 and # 12) which can be set individually.

Disassembly Conditions

When switching to a circuit and immediately switching to another circuit, delivery of one waiting packet is normally guaranteed. However, if the radio output buffer (RxD) has less than 128 bytes free (out of 255), or if flow-control of RxD is off, then no packets or service signals will be delivered before the switch is executed.

If service signals are deferred in the command mode (optional), then a waiting reset signal for the current circuit will not be delivered until the radio is changed to the data-transfer mode.

Adaptive Dynamic Access (ADAP)

The following compares Monicor's new (Ver 2.2 and higher) adaptive dynamic access protocol (ADAP) to the regular access protocol (RAP), and the aspects which can be varied, so that you can determine the best configuration for a given system.

This is the protocol between radios, not at the RS-232 port. The use of ADAP vs RAP (with or without conserve) has no effect on the user interface except to the extent that throughput and response time are affected.

Monicor radios have used RAP to support link operation since version 1.0, and this is still the factory default radio protocol in version 2.2. ADAP is expected to be better for every network, but is not the default protocol since it is not compatible with radios already using RAP on a network.

All radios must be configured for either RAP or ADAP -- a mixture cannot be used on a given network.

In RAP, the controller initiates exchange of data with each portable in a fixed sequence, including portables that may be inactive or even turned off. To save battery power, portables do not respond unless needed, so the controller cannot determine when a portable is turned off or out of range. RAP provides a system with maximum worst-case throughput, but since most systems rarely operate in the worst-case (every portable has continuous upload and/or download traffic), some throughput of active radios is sacrificed for availability of inactive radios. Approximately 33 milliseconds of radio channel capacity is used in addition to the time for actual transfer of user data bits. This lost capacity (or overhead) is used each time a packet exchange between the controller and a portable takes place, but also for each unused opportunity for exchange. The overhead time includes radio turn-around time, packet framing, addressing, and error checking / correction.

In ADAP, the controller determines which links are inactive and reduces (and then eliminates) the overhead wasted on them. This is achieved by sacrificing some of the throughput by the worst-case system load in order to make some channel capacity available for signaling by inactive radios. A typical snapshot of a system will find a significant number of users inactive (not waiting for data to be transferred), while others who are active could benefit from an increased throughput, and the decrease in worst-case performance is not nearly as significant.

The opportunity or actual packet exchange is called a poll, and the sequence of allowing or exchanging packets with each portable is called a poll cycle, since the sequence is repetitive. The poll cycle can be thought of as an entity in the controller. In RAP it consists of the number of link-polls defined by the value of the link quota setting, but in ADAP the sequence and number of link-polls is determined dynamically.

ADAP Configuration

The ADAP link operation is enabled and controlled by several new "facilities" commands, under "Facilities Link".

The ADAP default parameter values are optimized for most general installations, and should not have to be changed. All you need to do is enable the Dynamic mode.

A typical scenario might be a system where a user performs one or more transactions within a second or so, and then ten seconds or a minute elapses before the user begins the next transaction. After the cluster of transactions, the user is dropped from the poll cycle, and is added to the poll cycle when the next transaction begins.

To make the system "less dynamic", increase the dynamic drop interval so that users are not dropped until they are inactive for a much greater time. Set the controller dynamic skip to zero to get RAP-like performance for the active users.

For more details on ADAP, see "Facil Link Conserve" and "Facil Link Dynamic Mode" under "Facilities" in the "PAD Command Syntax" section.

Data Transfer Timing

This section applies to LINK OPERATION, with dynamic mode disabled.

The forwarding and reception of formatted messages over the radio link is virtually transparent. As data is input to a remote radio or network controller from the terminal, the messages are formatted internally into individual packets. The packets are transmitted under the control of the network controller, along with routing information.

All units can hear packets from any other. However, only the destination unit stores and forwards each packet. Received packets are then checked for errors. When an error is detected, the packet is repeated as necessary.

Information packets may be of variable length, up to a maximum of 128 bytes of data. If a packet contains only a few bytes, it will take a shorter time to send the packet.

The network controller communicates to each remote radio circuit in the network sequentially. It will normally be configured by the user to sequentially access the maximum number of remote radios on the system (Link Quota).

The network controller continuously interrogates each remote radio to determine its network status; i.e., whether it has been reset, is ready to transmit data, or is ready to accept data. Packets are exchanged between each remote radio and the network controller as the network controller accesses each remote radio.

Packets originating from a remote radio will be transmitted after that radio has been specifically accessed. The packet will be transferred to the serial port after the host has engaged the circuit to the specific remote radio.

If the remote radio is taken out of range, and a packet is then queued for sending in the remote radio, the remote radio will accumulate messages in its buffer until it is nearly full. At that point, the remote radio will issue a flow control signal at the RS-232 port, inhibiting additional information until it has more space in its buffer. When the remote radio has re-established contact with the network controller, packet flow will continue, and there will be no loss of data.

The network controller can sequentially access approximately 30 remote radios per second when not exchanging data (4800 bps radio). Fewer remote radios are accessed per second whenever data exchange takes place. The additional time is one second per 600 characters transferred in each direction.

Important:

If the host experiences a power failure, and has to re-boot, it is advisable to issue a REStart to the network controller. Even though the network controller (some models) have an internal battery, and information on the network will not be lost, if the host is disrupted, there is no guarantee that the host will be able to recover without losing data.

The Host will need to run the application program with the most recent good files saved before loss of power. At that point, it is best to start the rest of the system from a known state, and indicate to the portable terminals, if possible, that the host is re-starting its program.

Link Operation for 4800 bps radios.

link size:	4	5	6	7
maximum packet:	16	32	64	128
minimum edit buffer size:	31	63	127	255
max throughput:	266	369	457	518 (char/sec)
minimum quota for delay:	17	12	8	5

Minimum quota for delay is the quota giving a worst-case delay of approximately two seconds round-trip for a short packet if all other circuits constantly transfer full packets. (If all other circuits were idle, the minimum quota would be 30 with dynamic mode disabled).

Performance for 2400 bps radios is almost exactly half of that of the 4800 bps radios.

Programming Hints To Speed Host Response Time

A general technique used for determining if received data is waiting in the network controller for circuit access by the host from is to use the status subcommand, by accessing circuit zero.

After switching to circuit zero (using #00#), the "i" command, followed by a carriage return <CR> will return the number of each circuit with received messages. If a dash "-" is returned, no circuits have received messages.

Once the host has switched to circuit zero, the status subcommand i (or others) may simply be issued with an i<CR> sequence for as many times as necessary, while still on circuit zero. When it is desired to change circuits the appropriate #-digit-digit-# command is issued and the network controller will reply with the appropriate #-digit-digit-# response.

Status checks can be made as often as desired, without slowing the speed of the message transfer over the RF network.

After determining that there is received data on one or more circuits, the host can switch directly to each circuit and avoid switching to idle circuits to increase efficiency, especially for a large circuit quota.

For some applications, it may be desirable to remain with one circuit for a while, until data is transferred, before switching to another circuit. If it is desired to give other circuits more or less equal priority, the following method might be considered.

If the status subcommand response to the input command indicates messages on multiple circuits, such as 2,3,4, the host could issue the immediate sequence without waiting for a response:

```
#02##03##04##00#i<CR>
```

The response will be:

```
#02#(message from 02 here)#03#(message from 03 here)#04#(message from 04 here)#00#<CRLF>i 2,3,4
```

(Note: the i will not be echoed in the Transparent Profile)

This queues the switch commands so the network controller replies with one packet from each of the three circuits. The network controller will begin delivering the data received from the first circuit, preceded by the circuit switch echo (signal). If the network controller gets the command to switch to another circuit (as would happen with the above sequence), it will switch circuits at the next packet boundary of data from that circuit.

The controller will indicate the switch to the host by echoing the command sequence #-digit-digit-# to allow the host to route data to the appropriate file or task. The circuit-switch response is not optional, and is not related to data-echo options.

For example, if the terminals each sent an 80 character line of data, the command

```
#02##03##04##00#i<CR>
```

would be used three times. After the first and second time, the status subcommand "i" would indicate that there is still data in circuits 2,3,4. After the third time, if no additional data were received, the "i" command would indicate "-".

Note that if outgoing data is to be inserted into the above sequence, the host would need to wait following each circuit switch after which data is to be sent, until the echo of the switch is received. At the point the switch echo is received (the last "#"), the current flow status for transmitted data will properly reflect the destination circuit's status and whether the outgoing data can be sent.

This is not necessary though, if the "o" or "%" subcommand is used to determine which circuits are flushed of outgoing data. The "o" subcommand returns those circuit numbers with outgoing data still present. The "%" subcommand returns complete circuit status in one character for each circuit.

A flushed circuit can accept two packets plus 2^N-1 characters (send queue and edit buffer, $N = \text{Link Size}$) without loss. The host may send this much if the outgoing circuit is flushed without waiting at the switch to find out the flow control status.

If this method of circuit flow control is used, you will probably want to "disassociate" flow control from the current circuit so that several circuits of output can be concatenated and ordinary flow control can be handled at the operating system level.

PAD COMMANDS

Below is a list of valid commands (in the command mode) to configure the radios to your specific environment and operating conditions.

Baud	show primary UART parameters
Communicate	go to data-transfer mode
Default	set all parameters to default values
Facilities	show primary values
Help	show basic command list
Identify	show version, options
Profile	show value
REStart	reset all circuits
Reset	reset current circuit
SEt	show flow-control value
Status	show current circuit status
Write	write power-up values

The question mark command is useful at any point where you cannot remember the exact command name or syntax.

Spaces, tabs, and line-feeds are generally insignificant except to separate items where desired. Commands are limited to 191 characters, including the terminating carriage-return or plus character.

The minimum command word letters are echoed in the same case as entered. Remaining letters are echoed before entry, usually in lower case.

If an error was encountered during command entry and the last command character is deleted, all other characters back to and including the one causing the error are deleted from the command buffer at the same time.

Commands either display information or set parameters or both. Where not shown below, commands issued without the final parameter will display the current value of the parameter without changing it. Note that many Facilities commands which set parameters may cause circuits to be reset. Also, many commands which affect the PAD Profile can cause the serial input to be briefly turned off. If another command is issued immediately following the one affecting the profile, one or more characters may overrun the UART while serial input is disabled (TxD). To prevent this loss, the following command should wait for the response and prompt following the preceding command.

IMPORTANT

*If the baud setting of the serial port is changed, the response and prompt will be at the original baud setting; wait for the * before issuing additional commands. The additional commands need to be issued at the new setting.*

The numbers shown in the command syntax are generally the maximum allowed parameter value. The value in parentheses is the default value (from firmware). All command words may be abbreviated, the upper-case portion is the minimum abbreviation.

Indented under some of the commands below are detailed lists of the meaning of the parameter values.

Complete List Of Pad Commands

Syntax	Default	Function
Baud		show primary UART parameters
Baud Initial		use power-up baud values
Baud Rxdbkmod 1	(0)	set value
Baud Txdbkmod 1	(0)	set value
Baud Xtrastop 1	(0)	set value
Baud 19200	(9600)	set rate
Baud 19200 None	(none)	set rate, parity
Baud 19200 Odd	(none)	set rate, parity
Baud 19200 Even	(none)	set rate, parity
Baud 19200 Mark	(none)	set rate, parity
Baud 19200 Space	(none)	set rate, parity
Baud 19200 None 7	(8)	set rate, parity, data
Baud 19200 None 8	(8)	set rate, parity, data
Baud 19200 None 8 1	(1)	set rate, parity, data, stop
Baud 19200 None 8 2	(1)	set rate, parity, data, stop
Baud None	(none)	set parity
Baud Odd	(none)	set parity
Baud Even	(none)	set parity
Baud Mark	(none)	set parity
Baud Space	(none)	set parity
Baud None 7	(8)	set parity, data
Baud None 8	(8)	set parity, data
Baud None 8 1	(8)	set parity, data, stop
Baud None 8 2	(8)	set parity, data, stop
none 7 1 *-----		<--invalid, stop bits changed to 2
parity 7 1		
none 8 1		
parity 8 1 <-----+		
none 7 2 <-----'		
parity 7 2		
none 8 2		
parity 8 2 *-----		<--invalid, stop bits changed to 1
Communicate	(1)	go to data-transfer mode on specified circuit.
Communicate 99	(1)	go to data-transfer mode on specified circuit
Default		set all parameters to default values from firmware
Facilities		show primary values
Facilities Green 1	(0)	set value
0		green lamp blinks when circuit data or reset commands present in radio, does not blink when flushed.
1		green lamp is tied directly to transmitter "Send" control, green is ON when transmitter is ON.
Facilities Initial		use power-up facility values
Facilities Link		show link values

Complete List Of Pad Commands (Cont.)

Syntax	Default	Function
Facil Link Conserve 1	(0)	conserve battery power
Facil Link Dynamic Drop 255	(89)	set controller drop interval
Facil Link Dynamic Drop 255	(41)	set portable drop interval
Facil Link Dynamic Mode 1	(0)	use dynamic protocol (ADAP)
Facil Link Dynamic Latency 127	(20)	set basic latency interval
Facil Link Dynamic Retry 7	(4)	set data packet retry limit
Facil Link Dynamic Skip 7	(2)	set controller poll skip level
Facil Link Dynamic Test 255	(95)	set portable link test interval
Facil Link Dynamic Test 255	(0)	set controller test interval (N/A)
Facilities Link Enable	(true)	enable link operation
Facilities Link Quota 99	(1)	set value (controller only)
Facilities Link Number 99	(1)	set value (portable only)
Facilities Link Size 7	(5)	set value
4		maximum packet size is 16 byte
5		maximum packet size is 32 byte
6		maximum packet size is 64 byte
7		maximum packet size is 128 byte
Facilities Multidrop		show value
Facilities Multidrop Enable	(false)	enable multidrop operation (factory option, rev a only)
Facilities Protocol		show interface type
Facilities Protocol Buffer 12	(6)	set value
Facilities Protocol Full 255	(22)	set value
Facilities Protocol Prefix 255	(13,10,7)	set value of string
Facilities Protocol Prefix 255, 255 ...	(up to 8 values)	
Facilities Protocol Suffix 255	(7,13,10)	set value of string
Facilities Protocol Suffix 255, 255 ...	(up to 8 values)	
		Note that there are a maximum of ten actual characters of prefix and suffix, so that if the total length of both is greater than ten, then the end of the prefix and the beginning of the suffix overlap (the sequence is the same).
Facilities Red 1	(0)	set value
0		red lamp blinks about twice a second when battery is low (but does not indicate power-on).
1		red lamp also "blips" every couple of seconds to indicate power is on (if battery is not low).
Help		show basic command list
Identify		show title, date
Identify *		show all
Identify Frequency		show value
Identify Net-id		show value
Identify Power-up		show power-up flags, if any.
Identify Serial		show value
Profile		show value
Profile Binary	(editing)	set parameters
Profile Editing	(editing)	set parameters
Profile Initial	(editing)	set par's to power-up values
Profile Standard	(editing)	set parameters
Profile Transparent	(editing)	set parameters

Complete List Of Pad Commands (Cont.)

Syntax	Default	Function
REStart		reset all circuits
Reset		reset current circuit
Reset 99		reset specified circuit
SEt		show flow-control value
SEt *		show all values in tabular format (ParNo ParNam = ParVal)
SEt <par> = n		set parameter(s), any number of
SEt <par> : n		parameters can be set/shown by
SEt <par> ; n		same command (either of 3
SEt <par> = n [, par [= n]] ...		chars = or ; or : assigns value)
		<i>Note: See <par> list in SEt command section.</i>
Status		show current circuit status
Status 99		show specified circuit status
		<i>Note that the following status commands are also valid in the data-transfer mode on circuit zero where the "Status" word is omitted.</i>
Status " <any text>		echo specified text, (factory option, rev a only)
Status %		show status of all circuits in binary form
Status *		show status of all circuits in tabular form
Status Battery		show battery status
Status Events		show event counters
Status Incoming		show incoming list
Status Outgoing		show outgoing list
Status Timer		show power-on timer
Status Zero		show event counters and reset to 0
Write Baud		write power-up values
Write Facilities		write power-up values
Write Profile		write power-up values

Baud

The Baud command sets the RS-232 baud rate and interface parameters of the radio modem for the current session. The change can become the power-on default with the Write Baud command.

The command is executed by typing B (Baud), then the first two digits (minimum) of the new baud rate, then the parity (one of the following characters: N/S/M/E/O), then the number of data bits (7 or 8), then the number of stop bits (1 or 2) followed by <CR>.

The following are valid baud rates:

50
75
100
110
134.5
150
200
300
600
1200
2400
4800
9600
19200

For example, to set the Baud at 9600, No parity, 8 data bits and 1 stop bit, type:

```
B 96 N 8 1 <CR>
```

The baud rate will change after the <CR>.

(Remember to change the Terminal baud rate after changing it on the radio modem.)

Valid settings of parity, for data bits and stop bits combinations are:

Data Bits	7	7	8	8
Stop Bits	1	2	1	2
Parity:	None	x	o	o
	Odd	o	o	x
	Even	o	o	x
	Mark	o	o	x
	Space	o	o	x

o = valid
x = invalid

Baud Initial

Baud Initial changes the baud settings to the original power-up baud values.

Baud Rxdbkrmod

If enabled, the radio will generate shorter breaks on RxD than normal, ranging from 215 to 35 milliseconds (+ 5 milliseconds) for different baud rates, and the break "stop" time will be 20 milliseconds. The default is disabled, generating a 245 millisecond (+ 5 milliseconds) break with a 100 millisecond stop (idle).

Baud Txdbkrmod

If the "txdbkrmod" function is enabled, the radio will recognize breaks as short as the normal character time plus 20 milliseconds. The radio will also detect breaks as short as 10 bit-intervals if the baud settings specify 10-bit characters (e.g. 1 start + 8 data + 1 stop) instead of 11-bit characters.

The default is not enabled, and a break must be 210 milliseconds or more to be recognized. If a break is not recognized as such, it will be interpreted as an ASCII "NUL" character.

Baud Xtrastop

If Xtrastop is enabled and the baud is 600 bits per second or less, the radio adds one extra stop bit to RxD (output) characters in addition to other stop bits specified.

TxD (input) character recognition is not affected.

Communicate

The Communicate command places the modem in the data transfer mode (communicate mode). Commands to enter the data transfer mode are:

"C <CR>"

Data transfer begins for the current circuit (the current circuit number is displayed).

"Cnn <CR>"

Data transfer begins for the specified circuit (nn), which becomes the new current circuit (no number is displayed).

At power-on, the current circuit is 01. When C <CR> is entered, data transfer begins for link number one (01). The network controller can communicate on any circuit by entering a C, the circuit number (nn), followed by a <CR>. For example, communicate with circuit 04 by entering:

C 4<CR>.

A portable radio only has one circuit (01), which goes to the network controller. If a remote is set to communicate on any other circuit, the data will be discarded.

Circuit-Switch command

While in data transfer, the host can switch to each circuit in the network by issuing a circuit switch command (#nn#). This character sequence is held in the network controller buffer until the full sequence of "#", digit, digit, "#" (4 characters) has been entered. Then it will echo the same 4 character sequence back to the terminal. This sequence separates any received data on the previous circuit from any on the new circuit, even if echo is off.

If a one-second guard time occurs between any of the four characters (unless *Gard* = 0, as for the Editing profile), the characters are treated as data instead of the circuit switch command.

If data from a remote is already in the receive queue when the host switches the interface to that circuit, then the network controller begins delivery of the data to the terminal immediately following the echoed circuit switch command.

The host will continue to receive packets queued from that remote until it switches to another circuit by issuing the circuit switch command. The host can remain on a circuit until all information is transferred, or it can limit information flow to a packet at a time by switching to other circuits to give them equal priority.

Switching circuits is a forwarding condition for all data sent to the previous circuit which has not been forwarded.

Using the Edit profile, incoming data delivery is blocked (locally) once any characters have been entered on the current line, to prevent conflict between incoming and outgoing-echoed messages on the terminal display. Once the line is forwarded (<CR>) or deleted, any incoming data is then delivered. (This function is enabled by *INtr* with Echo).

The host can query the network controller for circuit status while in the data transfer mode by switching to circuit zero (#00#). Circuit zero is a direct link to the subcommands of the Status command.

In contrast to switching to any other circuit, a <CRLF> is added to the circuit switch response when switching to circuit zero (#00# <CRLF>), i.e., the four character command #00# has a six character response instead of the normal four for any other circuit.

By using a status subcommand to see which circuits have data waiting, the host can switch directly to any of these active circuits without having to step through inactive ones.

Escape Communicate

Several options are available to return to the command mode, depending on the parameter settings. See the *Gard*, *PChr*, and *PPP* parameters for the "+++" PAD escape option. See the *Brk* and *Pad* parameters for other escape options.

Power-Up Mode

A radio will power-up in either the command mode, or the communicate mode, depending on the *Mode* parameter. The editing profile sets the power-up mode to command, and the transparent profile sets the power-up mode to communicate.

Default

This command sets all parameters to the factory default values for the installed firmware version. This is the same result as using a default configuration plug at power-up.

This does not affect the power-up values. If the radio is not already at the default factory baud, the terminal baud will need to be changed to

9600 N 8 1

after executing "default".

Facilities

The facilities commands control and enable various aspects of network operation.

Some of the following applies to portable radios, as well as controllers.

The four parameters Link Size, Link Quota, Protocol Buffer, and Protocol Full interact when set. The Link Size is fixed by command, and never modified due to changes to the other parameters. But the other three parameters can be modified by the radio when any of the four parameters are set, according to the following conditions, and in the following order (Note that Buffer is the edit-buffer size, and Full is the amount of remaining edit-buffer empty space to trigger flow-control off):

- 1) Link Size: Not changed by any other settings.
- 2) Link Quota: Decreased if not enough room for packet queues and edit buffers.
- 3) Protocol Buffer: Increased if not greater than link size (at least the minimum size), decreased if not enough room for quota buffers. The increase-condition also applies to portables.
- 4) Protocol Full: Limited to (edit buffer size - max packet size) to avoid flow-control-off from preventing entry of a full packet into the edit buffer. This also applies to portables.

The following table lists the maximum quota for a radio with either a standard or a large circuit memory, and the Link Size set as shown.

Std Memory:	Link Size	Max Quota
	4	52
	5	30
	6	16
	7	8
Large Mem:	Link Size	Max Quota
	4	99
	5	99
	6	75
	7	39

The network controller normally comes with standard memory. The large circuit memory is available by ordering a controller with the memory expansion option.

Facilities Green

When 0, the green lamp will blink when circuit data or reset commands are present in the radio. The radio will blink a minimum of one time for each message sent. When the queues are empty (flushed), the lamp will not blink.

When 1, the lamp is tied directly to the transmitter "Send" control. Whenever the transmitter is on, the green lamp is on.

Facility Initial

Facility Initial changes all the Facilities settings to the current power-up values.

Facility Link

This shows some of the link parameter values.

Facilities Link Conserve

Conserve, when set to "1", allows the receiver to be powered off for short periods of time while nothing useful can be received by the radio. This will save some battery power, the amount depending on the amount and kind of network activity on other circuits. Using conserve with RAP, the least power is saved during upload, more is saved in idle, and the most is saved in download transactions by other circuits. Using conserve with ADAP, even more is saved during network idle. (Conserve permits up to 65% longer operating time before a portable needs recharging).

Conserve will interfere with the normal operation of an audio test device connected to the radio, since the receiver is intermittently off. If an audio test is required, set conserve to zero.

Facilities Link Dynamic Mode

ADAP is enabled when the Dynamic Mode value is "1" for every radio in a network (each must be set to the same value). This permits individual portable radios to be dynamically dropped from and added to the controller poll cycle.

ADAP throughput is better than RAP in most cases, especially for larger systems, since 33 milliseconds (67 milliseconds for 2400 baud radios) of wasted overhead is eliminated from the poll cycle for each portable which is idle. But throughput for a 100% fully loaded network (non-stop traffic on each and every circuit) will be as much as 10% lower using ADAP.

Response time is generally better, depending on the parameter values in use. Although additional delay is incurred by a portable radio in getting the controller to add it back to the poll cycle (once it has been dropped), the smaller poll cycle may more than compensate.

The remaining "Dynamic" commands set parameters which influence ADAP operation. The influence of each parameter is explained below. (These parameters have no effect on RAP operation). These parameters are preset by the "Default" command and do not need to be changed except for unusual cases.

The factory default parameter values are good for most systems, but there may be a need to vary them in some cases. For example, if no extra "latency" time is desired, the drop times can be increased so that they are much longer than the normal typical user idle interval, and skip would also be set to zero. If on the other hand, you wanted to minimize useless overhead for a lot of periodic transactions, you might want to reduce the drop time, increase the skip a notch or two, and maybe also decrease retry. You might find that you just have to try different settings to get an improvement in a particular aspect of performance.

Facilities Link Dynamic Drop

The controller drops a circuit from the poll cycle after the circuit is inactive for the specified controller drop interval. In addition, the portable will volunteer to the controller to be dropped after being idle for the specified portable drop interval. The controller drop time should normally be set much longer than the portable drop time, however some systems may have a need to set some portable drop times longer than others. The portable drop time setting can differ between portables if needed. The controller factory default is eight seconds and the portable factory default is one second. (See the log-time section below to find the parameter value for a desired time interval).

Facilities Link Dynamic Latency

The first packet a portable uploads (after being dropped) will encounter an extra delay, which is affected by the controller latency value. The extra delay may actually be more or less than the latency value. The delay is for the portable to signal the controller to add it to the poll cycle.

The latency value influences the rate that signaling by inactive radios is allowed. So a shorter latency setting decreases the extra delay to start transfer, but also causes more overhead (and less throughput) in the network.

The latency value specifies a time with 10 milliseconds units (multiply the number by ten milliseconds). The portable latency should be set to the same value as the controller, since it is used for conserve timing during network idle. The factory default value is 200 milliseconds (1/5th second).

Facilities Link Dynamic Retry

Data packets are usually retransmitted if needed until the other end of the link acknowledges error-free reception. But dynamic polling will only retransmit data packets a limited number of times before sending a special request, which must be acknowledged before the data packet can be retransmitted. This parameter limits the number of times the packet is first sent. It also affects the controller drop-timer start. The retries are not counted past seven.

Facilities Link Dynamic Skip

Skip allows the controller to skip polls every so often once the retry count is exceeded. A poll will then only occur on the 2^N poll cycle, where N is the retry number minus the retry parameter, limited to a maximum of the skip parameter. (However, it is also limited by the radio not counting retries past seven). For example, the factory default value of two provides a minimum of one poll every four poll cycles (until the circuit is dropped from the poll cycle). So a portable might have to wait up to four poll cycles to get an upload started, even though it hasn't been dropped.

Facilities Link Dynamic Test

The portable initiates a link test periodically while it is dropped from polling. This puts the link back into the poll cycle if it was dropped while out of range and data needs to be transferred. The controller does not initiate a test. The test result does not affect the status of the circuit. The factory default test interval for a portable is ten seconds. (See the log-time section below to find the parameter value for a desired time interval).

Log-Time Conversion

The dynamic drop and dynamic test parameter values choose a time by using a number between 0 and 255. Use the table below to find the value which most closely represents the desired time in seconds. The maximum parameter value of 255 represents about 2.8 hours.

Value	Time	Value	Time	Value	Time	Value	Time	Value	Time
0	0.16	52	1.60	104	15.4	156	143.	208	1,311.
1	0.17	53	1.68	105	16.0	157	148.	209	1,393.
2	0.18	54	1.76	106	16.6	158	154.	210	1,475.
3	0.19	55	1.84	107	17.3	159	159.	211	1,556.
4	0.20	56	1.92	108	17.9	160	164.	212	1,638.
5	0.21	57	2.00	109	18.6	161	174.	213	1,720.
6	0.22	58	2.08	110	19.2	162	184.	214	1,802.
7	0.23	59	2.16	111	19.8	163	195.	215	1,884.
8	0.24	60	2.24	112	20.5	164	205.	216	1,966.
9	0.25	61	2.32	113	21.8	165	215.	217	2,048.
10	0.26	62	2.40	114	23.0	166	225.	218	2,130.
11	0.27	63	2.48	115	24.3	167	236.	219	2,212.
12	0.28	64	2.56	116	25.6	168	246.	220	2,294.
13	0.29	65	2.72	117	26.9	169	256.	221	2,376.
14	0.30	66	2.88	118	28.2	170	266.	222	2,458.
15	0.31	67	3.04	119	29.4	171	276.	223	2,540.
16	0.32	68	3.20	120	30.7	172	287.	224	2,621.
17	0.34	69	3.36	121	32.0	173	297.	225	2,703.
18	0.36	70	3.52	122	33.3	174	307.	226	2,785.
19	0.38	71	3.68	123	34.6	175	317.	227	2,867.
20	0.40	72	3.84	124	35.8	176	328.	228	2,949.
21	0.42	73	4.00	125	37.1	177	348.	229	3,031.
22	0.44	74	4.16	126	38.4	178	369.	230	3,113.
23	0.46	75	4.32	127	39.7	179	389.	231	3,195.
24	0.48	76	4.48	128	41.0	180	410.	232	3,277.
25	0.50	77	4.64	129	43.5	181	430.	233	3,359.
26	0.52	78	4.80	130	46.1	182	451.	234	3,441.
27	0.54	79	4.96	131	48.6	183	471.	235	3,523.
28	0.56	80	5.12	132	51.2	184	492.	236	3,605.
29	0.58	81	5.44	133	53.8	185	512.	237	3,687.
30	0.60	82	5.76	134	56.3	186	532.	238	3,769.
31	0.62	83	6.08	135	58.9	187	553.	239	3,851.
32	0.64	84	6.40	136	61.4	188	573.	240	3,933.
33	0.68	85	6.72	137	64.0	189	594.	241	4,015.
34	0.72	86	7.04	138	66.6	190	614.	242	4,097.
35	0.76	87	7.36	139	69.1	191	635.	243	4,179.
36	0.80	88	7.68	140	71.7	192	655.	244	4,261.
37	0.84	89	8.00	141	74.2	193	696.	245	4,343.
38	0.88	90	8.32	142	76.8	194	737.	246	4,425.
39	0.92	91	8.64	143	79.4	195	778.	247	4,507.
40	0.96	92	8.96	144	81.9	196	819.	248	4,589.
41	1.00	93	9.28	145	87.0	197	860.	249	4,671.
42	1.04	94	9.60	146	92.2	198	901.	250	4,753.
43	1.08	95	9.92	147	97.3	199	942.	251	4,835.
44	1.12	96	10.2	148	102.	200	983.	252	4,917.
45	1.16	97	10.9	149	108.	201	1,024.	253	5,000.
46	1.20	98	11.5	150	113.	202	1,065.	254	5,082.
47	1.24	99	12.2	151	118.	203	1,106.	255	5,164.
48	1.28	100	12.8	152	123.	204	1,147.		
49	1.36	101	13.4	153	128.	205	1,188.		
50	1.44	102	14.1	154	133.	206	1,229.		
51	1.52	103	14.7	155	138.	207	1,270.		

Facilities Link Enable

This enables Link operation, and disables multidrop operation.

Facilities Link Quota

This command is used on the Network Controller to set the Link Quota to the number of remote radio modems that will exist on the network. The default value is one.

To set the Link Quota to seven on a Network Controller, type:

```
FLQ 7 <CR>
```

Circuit numbers from 1 to 99 are valid. Number zero is an invalid circuit number and is dedicated to the status sub-commands. The maximum link quota depends on the Link Size (packet size).

Important:

The Network Controller begins sending radio signals to each link number in the quota when it is turned on. If you need to place the transmitter in standby, set the Link Quota on the Network Controller to zero. Active operation resumes when the Link Quota is changed from zero to non zero. All circuits will be reset (undelivered data discarded from queues) by this sequence.

Facilities Link Number

This command is used on a portable radio modem to set the Link Number of that radio. Each portable radio *must* have a unique Link Number.

To set the link number to 7 on a radio modem, type:

```
FLN 7 <CR>
```

Facilities Link Size

This command sets the maximum packet size for radio transmission. It also establishes the packet size for the send and receive queues, along with the edit buffers. The factory default is 5, which is 32 characters.

The edit buffer size can be set independently of the link size.

Since Link Size determines the memory allocation for send and receive queue size, it changes the number of queues available, and consequently the link quota. The larger the packet size selected, the fewer number of radios possible on the network.

When messages are transferred over the radio, a longer packet has a higher probability of being detected with an error than a shorter packet. Consequently, the radio will have a slightly smaller area of coverage with a link size of 7 than that of a link size of 4 or 5.

The size is the logarithm-base-two of the maximum packet size, resulting in valid values of 4, 5, 6, or 7.

Any change in the maximum packet size causes a restart. Note that all radios on a network must be set to the same maximum packet size or the corresponding circuits will probably become jammed (stuck).

Facilities Multidrop

This shows whether multidrop is enabled or disabled.

Facilities Multidrop Enable

Enables multidrop operation. A version "a" firmware level must be present for multidrop to function. The default value is *not enabled*. (firmware level "a" is an option purchased with a radio.)

Facilities Protocol

This command indicates the current radio interface and operation type.

Facilities Protocol Buffer

This command sets or displays the current size of the edit buffer(s). The size is $2^N - 1$, e.g. size 6 is 63 characters for each buffer.

Facilities Protocol Full

This command sets the flow control off/on threshold (high-water mark). Flow control will go off when the specified free space (or less) exists in the current edit buffer (in the data transfer mode). This does not apply if the flow control type is set to 4 or more, but the protocol full will still affect related status results.

Facilities Protocol DCE
Reserved**Facilities Protocol DTE**
Reserved.**Facilities Protocol Escape**
Reserved.**Facilities Protocol Flag**
Reserved.**Facilities Protocol Interface**
Reserved. *Must be zero!***Facilities Protocol N2**
Reserved.**Facilities Protocol Prefix**

This command defines / displays the prefix character(s). The prefix is an optional output preceding some service signals and packet data (e.g. used with INtr enabled.)

Facilities Protocol Suffix

This command defines/displays the suffix character(s). The suffix is an optional output preceding some service signals and packet data (e.g. used with INtr enabled.)

Facilities Red

When set to 0, the red lamp blinks about twice a second when the battery is low.

When set to 1, the red lamp also "blips" every couple of seconds to indicate that the power is on.

Help

The Help menu is available in the PAD command mode. Typing H <CR> will give the following response:

```
Baud
Communicate
Default
Facilities
Help ?
Identify
Profile
Reset
REStart
SEt
Status
Write
*
```

Typing a ? at the command prompt level will give the following response:

```
*<?> baud communicate default facilities
help identify profile reset restart set status
write <CR>
```

The "?" character can be entered at any point during command entry to obtain a list of the valid possibilities for the next element of the command (context-sensitive help). The list is followed by a repeat of the current command entry (similar to the DC2 editing function). The question-mark is discarded. If a portion of a command word is entered which is ambiguous (more than one choice in the "?" list start with those same letters) then the last compatible choice is assumed. This is why the list is not always in alphabetic order. Whitespace (spaces, tabs, line-feeds) are allowed anywhere except within words or numbers. The "?" command forces the default word if the current entry is ambiguous. Therefore, the "?" may assume a current entry word and show the resulting next options whereas the next character(s) entered invalidate the default assumed for the former entry (and of course the resulting next options). For example, "S?" will assume "Status" and display the status subcommands, but if the next character entered is "E" then "SEt" will be taken as the first command word.

As many successive letters as match a command word are taken as representing that word. For example, the following entries are equivalent:

```
STATUS TIMER
STATUSTIMER
STAT TIM
STATT
STA T
STT
S T
```

Identify

Identify provides version information, type of radio, and optionally, serial number and frequency.

Profile

The "Profile" command sets or shows the current PAD profile.

The "Profile" refers collectively to the settings of all of the PAD "SEt" parameters. The Binary, Editing, Standard, and Transparent profiles each support a different general requirement. A fifth profile, "Initial", is the set of customer configured parameters at power-on.

The profiles are simply a starting point for selecting the "SEt" parameter values, and any profile can be modified to any degree. See the *SEt* command.

The general characteristics of the four PAD parameter profiles reflect the interface needs of four typical applications.

The *editing profile* is useful for supporting a conversational mode between two "dumb" terminals.

The *standard profile* is useful where a simple interface providing echo is needed.

The *transparent profile* is most widely used and is preferred for communications requiring that no characters are filtered, added, or echoed.

The *binary profile* is a subset of the transparent profile which disables all character-based commands, and is therefore unsuitable for a controller handling multiple circuits through the PAD interface.

Editing Profile

With the *editing* parameter values, limited editing is provided for a number of characters or until entry of a <CR>. The number of characters is determined by the flow control threshold, which also determines the size-based forwarding condition. All terminal output is echoed back to the terminal. XON/XOFF (default) flow control is active. A <CR> automatically adds a <LF> for both echo and transmission to the remote terminal. The reception of <LF> causes an extra <CR> to be automatically inserted.

When received data switches between incoming, and outgoing-echoed, an extra <CR><LF> is inserted in the received data.

When more than 80 characters are received or echoed without a <CR><LF>, then a <CR><LF> is inserted in the received data stream (line folding).

The editing functions provided are:

- 1) previous character deletion using ;
- 2) buffer (line) delete using <^X>;
- 3) buffer re-display using <^R>.

The Edit buffer contents are forwarded to the remote terminal on receipt of a <CR> from the terminal. No forwarding idle time-out is applied, so a partially full buffer without a <CR> will remain indefinitely, without being forwarded to the remote terminal. Control-P (^P) escapes from data transfer, as well as <1 sec idle> + + + <1 sec idle>.

Standard Profile

The Standard profile parameter values are similar to the editing values, providing echo and flow control, but omitting all editing functions and CR/LF insertion. All control characters are forwarding characters, as well as <CR>. There is no forwarding idle time. Escape from data transfer is the same as for the editing profile.

Transparent Profile

Transparent profile parameter values allow all characters to be sent, (with the exception of circuit switches and escape sequences) facilitating the transfer of non-text data. There is no echo, no forwarding characters, or XON/XOFF flow control (unless modified), and all PAD service signals are suppressed. Also, the

<1 sec idle> + + + <1 sec idle>

escape command is the only means enabled to escape from the data transfer mode. Flow control is provided by the DTR/CTS interface signals, and the forwarding idle timer is set to 10 milliseconds, so data is forwarded either when a full packet of data is buffered (32 characters for Link Size 5) or when the idle timer expires (transmitted data is idle for at least 10 milliseconds). If "transparent" is the initial profile, the radio interface will immediately go to the data transfer mode at power-on.

The Transparent Profile allows service signals enabled with a custom prefix and suffix string added. This allows for the explicit detection of a circuit reset.

The Transparent Profile allows specially marked delivery of packets received from any and all circuits while the current circuit is any circuit.

Binary Profile

The Binary profile parameter values disable the circuit-switch sequence and the plus-plus-plus PAD escape sequence. A transmitted Break causes escape to the PAD command mode.

The abbreviated commands to set Edit, Initial, Standard, Transparent and Binary are:

PE<CR> (Sets profile to Edit),
 PI<CR> (Sets profile to Initial),
 PS<CR> (Sets profile to Standard),
 PT<CR> (Sets profile to Transparent),
 PB<CR> (Sets profile to Binary).

Initial Profile

The Initial profile is defined as the power-on profile, and can be one of the four pre-defined profiles: Binary, Edit, Standard, Transparent, or any modification of these. Any parameter values can be put in the initial profile by performing the Write Profile command while the desired settings are active.

Reset

The Reset command resets an individual circuit. The current circuit is reset, unless specified by a number in the command.

R <CR> resets current circuit,

R 7 <CR> resets circuit number 7.

The current circuit is circuit number one at power-on, otherwise, it is the last circuit that data transfer took place on, i.e., the most recent #nn# or C nn <CR> command determines the current circuit.

Note that the active circuit in a portable radio is always number one regardless of the link number. If the current circuit of a portable is not number one, data transfer is blocked.

A reset causes all undelivered data to be discarded from the send and receive queues, and edit buffer of a circuit, at both ends (radios).

The reset of a circuit will cause an indication (service signal) to be delivered on the other end of the circuit unless service signals are disabled on that radio. A service signal will also be delivered to the radio which initiated the reset if a problem occurs performing the reset (unless also disabled).

If the signal indicates either NET-DOWN or DTE-DOWN, the circuit is not operational. The NET-DOWN signal occurs about a minute after the reset command if not performed. However, the reset of the circuit is still pending resolution of whatever problem exists, and no additional reset is needed.

Any other signal assumes normal operation of the circuit. See service-signal list items 28-31, and the "Sigs" parameter.

REStart

The REStart command performs a restart, which is a reset of all circuits. For a network controller, this resets all circuits. For a portable radio, this resets only the one circuit.

A restart is also automatically performed when turning on power to the network controller or portable modem, and on a DTR off-to-on transition if Flow control = 2 (Rflo = 2).

A system does not normally need to use the REStart command.

SEt

PAD Parameters

The SEt command shows and/or sets the values of one or more of the PAD profile parameters.

All of the PAD parameters are controlled individually. These are the components of the profile. A profile is a complete set of PAD parameter values. The active profile is the set containing each value currently in use for each PAD parameter. To 'SEt' a parameter is to modify the current profile. Writing the profile forces the Initial Profile to be the same as the active profile.

In other words, 'write profile' sets the initial value of all of the PAD parameters to the value currently set. 'Profile Initial' sets all the PAD parameters to their current power up values.

The PAD parameters are either standard (CCITT X.3) or non-standard (Monicor-defined). The standard parameters are numbered from 1 through 22, and the non-standard parameters are numbered from 101 through 109. A parameter can be referred to by either its number or its name. Many 'standard' parameters have been modified slightly (from the X.3 specification).

Multiple parameters can be set or read by a single SEt command. If a value is set more than once in the same command, the last value prevails.

If more than one parameter is being shown and/or set, the parameter names (or numbers) are separated by commas. The command response will also have as many commas.

To set a parameter, the parameter name (or number) is followed by the assignment operator (= or : or ;) and a value. The value of any parameters not being set are shown in the command response (in the corresponding position).

The response format is one or more commas, if two or more parameters are referenced, followed by a CRLF. If a parameter value is being assigned, no value is displayed in the corresponding position of the response.

For example (starting with Profile Edit):

command: SE P,E,FO=2,6,FOL,15=1<CR>

response: 16,1,,23,80,,<CRLF>

If any part of the command is invalid, no parameters are changed.

The following PAD "SET" parameters make up the content of the PAD profile. A parameter can be referred to by either its number or name (word).

The four values in parentheses are the Editing, Standard, Transparent, and Binary profile values, in that order.

Number	Name	Max	Profile	Description
1	Pad =	255	(16,16,0,0)	PAD escape char
2	Echo =	1	(1,1,0,0)	local echo enable
3	FOrw =	255	(2,126,0,0)	packet forwarding on certain char's
4	Idle =	255	(0,0,1,1)	packet forwarding on idle-timer
5	Tflo =	7	(1,1,3,3)	TxD data flow control
6	Sigs =	255	(23,23,22,22)	service signals
7	Brk =	255	(0,0,0,8)	response to break
8	TOss =	1	(0,0,0,0)	discard data
9	CR =	255	(0,0,0,0)	CR padding in char-intervals
10	FOLD =	255	(80,0,0,0)	line folding (insertion of CRLF)
11	BAud =	15	(,,,))	Serial data bit rate (read only)
12	Rflo =	3	(1,1,3,3)	RxD data flow control
13	Auto =	255	(22,0,0,0)	auto LF insert
14	LF =	255	(0,0,0,0)	LF padding in char-intervals
15	EDit =	1	(1,0,0,0)	editing enable
16	CDel =	255	(127,127,127,127)	char delete char
17	LDel =	255	(24,24,24,24)	line delete char
18	DISp =	255	(18,18,18,18)	line display char
19	TYpe =	255	(2,2,2,2)	editing service-signals.
20	MAsk =	255	(0,0,0,0)	echo mask
21	PARi =	1	(1,1,1,1)	check parity (else ignore parity)
22	Wait =	255	(0,0,0,0)	page wait
101	PPp =	1	(1,1,1,0)	PAD-recall w/ +++ enabled
102	Circ =	1	(1,1,1,0)	circuit switch command enable.
103	ModE =	1	(1,1,0,0)	power-up mode
104	INtr =	3	(1,0,0,0)	receive intrudes echo
105	PChr =	255	(43,43,43,43)	value of char treated as "plus" char
106	DLim =	255	(35,35,35,35)	circuit switch delimiter char.
107	Gard =	255	(0,0,25,25)	guard-time (40 ms units, 25 = 1 sec)
108	SUB =	255	(26,26,26,26)	Substitute character
109	DEad =	7	(0,0,0,0)	Dead-command test
Flow-control	=	7	(1,1,3,3)	both Rflo & Tflo (Rflo is modulo 4)

The values and meanings below apply to the above parameters. Note that "(sum)" above the parameter values indicates that several options are available simultaneously by adding the desired values. The parameter value is zero if none of the non-zero options are desired.

Complete List of "SET" Parameters

Number	Name	Value	Meaning
13	Auto	(sum) 1 2 4 8 16 32 64 128	Auto Carriage-Return/Line-Feed insertion insert LF on CR in disassembled data insert LF on CR in assembled data insert LF on CR in echoed data (reserved) insert CR on LF in disassembled data insert CR on LF in assembled data insert CR on LF in echoed data (reserved)
11	BAud	value 0 1 2 3 4 5 6 7 8 9 10 11 12 13 14 15	serial data bit rate 110 bps 134.5 bps 300 bps 1200 bps 600 bps 75 bps 150 bps 1800 bps 200 bps 100 bps 50 bps not used 2400 bps 4800 bps 9600 bps 19.2 Kbps
7	Brk	(sum) 0 1 2 4 8 16 32 64 128	response to break on TxD line Break Ignored (except escape from command entry - always done in command mode). (reserved). Reset Circuit. Indication of break XXX-Brk-XXXcrlf (overrides simple brk-echo if echo is on) Escape from data-transfer mode. Discard output (sets TOss = 1) (reserved). (reserved). Send RxD break on Reset signal (even if service signals suppressed).
16	CDel	value	Char Delete char - command character for character-delete editing
102	Circ	1/0	circuit switch command enable/disable.
9	CR	value 0 other	CR padding in character-intervals none specified idle follows CR

Complete List of "SET" Parameters

Number	Name	Value	Meaning
----	----	----	-----
109	DEad	value 0 other	Dead-command test no dead-cmd test. dead-cmd cancellation after $2.56 * 2^n$ seconds of idle (5/10/20/41/82/164/328 sec).
18	DISp	value	line display char (repeat)
106	DLim	value	circuit switch delimiter char.
2	Echo	1/0	local echo enable/disable
15	EDit	1/0	editing enable/disable
	Flow-control		set value of both Rflo & Tflo (Rflo is set modulo 4)
10	FOLd	value 0 even odd	line folding (insertion of CRLF) none fold line after nth printing char, assume cursor stays in last column fold line after nth printing char, assume cursor always moves
3	FORw	(sum) 0 1 2 4 8 16 32 64 128	packet forwarding on certain characters No data forwarding on any character values. 0-9, A-Z, a-z CR ENQ, ACK, BEL, ESC DC2, CAN, DEL ETX, EOT HT, LF, VT, FF all other control (reserved)
			48-57, 65-90, 97-122 13 5-7, 27 18, 24, 127 3-4 9-12 0-2, 8, 14-17, 19-23, 25-26, 28-31 (reserved)
107	Gard	value 0 other	guard-time (40 ms units, 25 = 1 sec) Guard interval is one second for +++ and N/A for circuit switch Guard interval in 40 ms units for +++ and circuit switch
4	Idle	value 0 other	packet forwarding on idle-timer No idle-timer forwarding idle-timer forwarding interval in 10 ms units.

Complete List of "SEt" Parameters

Number	Name	Value	Meaning
----	----	----	-----
104	INtr	(sum) if Echo is on: 1 2 if Echo is off: 0 1 2	rcv intrudes echo Rcv with extra CRLF separator between Rcv & Echo and vice-versa (else no extra separator). Rcv anywhere in echo (else Rcv between echo lines only, not in middle of line entry) Rcv from current circuit only (unformatted data) Rcv from any circ while on circ zero (formatted data) Rcv from any circ while off circ zero (formatted data)
			Note: "formatted data" means each packet is formatted as follows, where the digits indicate the circuit number of the received data: <prefix> <digit> <digit> <data> <suffix> The format also applies to service-signals if they are enabled. See the "Facilities Protocol" commands for prefix and suffix details.
17	LDel	value	line delete char
14	LF	value 0 other	LF padding in character-intervals none specified idle follows LF
20	MAsk	(sum) 0 1 2 4 8 16 32 64 128 note:	echo mask None masked (all echoed if std-par # 2 = 1) CR 13 LF 10 VT, HT, FF 9, 11-12 BEL, BS 7-8 ENQ, ESC 5, 27 SOH, STX, ETX, EOT, ACK, NAK, ETB 1-4, 6, 21, 23 editing chars of par's 16-18 <the par values> all other ctrl, DEL 0, 14-20, 22, 24-26, 28-31, 127 XON/XOFF are masked if std-par # 5, 12, or 22 are non-zero
103	Mode	value 0 1	power-up mode data transfer mode command mode
1	Pad	value 0 others	PAD escape char No escape-character Escape w/ that character
21	PARi	1/0	check parity / ignore parity
105	PChr	value	value of char treated as "plus" char
101	PPp	1/0	PAD-recall w/ +++ enabled/disabled
12	Rflo	value	RxD data flow control (see Flow Control section)

Complete List of 'SEt' Parameters

Number	Name	Value	Meaning
----	-----	-----	-----
6	Sigs	(sum)	service signals
		1	All service signals in either mode (except prompt). else No signals in data-transfer, all in command (except prompt)
		2	Echo in Command Mode (else no echo in command mode).
		4	Prompt service signals (apply only to command mode)
		8	Reset/Disconnect signals are deferred to data-transfer (on the corresponding circuit).
		16	Reset/Restart codes spelled out instead of numeric.
		32	Prefix instead of CRLF precedes reset service signals.
		64	Suffix instead of CRLF follows reset service signals.
		128	Prefix/Suffix are added before/after circuit-switch signals ("echo" of command).
108	SUB	value	Substitute character
		0	use error char as is.
		other	used to substitute for errors in the event of received TxD parity error.
5	Tflo	value	TxD data flow control (see Flow Control section)
8	TOss	1/0	discard data - discard all rcv'd data / discard none.
19	TType	value	editing service-signals.
		0	no response sent to terminal
		1	send "\ (92) to dte on any deleted edit-buffer character (printing terminals).
		2	send BS SP BS to terminal on deleted echoable graphic edit-buffer character (display terminals).
		8	send BS to terminal on deleted echoable graphic edit-buffer character.
		other	send that value char on any deleted edit-buffer character.
		Note:	"graphic" character is between 32 and 255, except 127 ("printable").
22	Wait	value	page wait function
		0	none
		other	return PAGE and wait for XON or echoed LF when the specified number of LF's are delivered to RXD.

SEt Auto

This parameter controls whether the radio inserts extra <CR> or <LF> characters into the receive data stream when <CR> or <LF> is recognized in the transmit and/or receive data.

SEt BAud

This parameter is read-only and indicates the current interface speed.

SEt Brk

This parameter controls the response of the radio when a break is recognized on the RS-232 TxD line. An extra option allows the radio to send a break on the RxD line when a reset signal occurs.

The radio can detect and generate short (modified) break signals if the corresponding Baud options are enabled. Otherwise, the transmission of a short break to a radio is interpreted as a NUL character (with a framing error).

If the value contains 128, then anytime a reset indication occurs (or would occur if "Sigs" set for suppression), the radio sends a break to the terminal on the RxD line.

SEt CDel

This parameter determines which character performs character-delete editing.

SEt Circ

This parameter enables or disables recognition of the circuit switch command.

SEt CR

This parameter allows the radio to create a desired idle time (padding) following any CR delivered on the RxD line. This is mostly used only by teleprinters which do not have buffered input and flow control.

SEt DEad

This parameter allows the radio to cancel a partially entered command after a specified idle time.

SEt Disp

This parameter determines which character performs line display for editing purposes. Line display echoes the editable content of the current edit/command buffer.

SEt DLim

This parameter determines which character is recognized as the circuit switch delimiter.

SEt Echo

This parameter controls whether local echo is enabled or disabled in the data transfer mode. Local echo in the command mode is controlled by the Sigs parameter. Echo also changes the meaning of the INtr parameter.

SEt EDit

This parameter controls whether editing is enabled or disabled in the data transfer mode. Editing is always enabled in the command mode. With editing on, a full packet in the edit buffer is not a forwarding condition. Instead, the edit buffer is able to be forwarded when it fills to the point where flow control shuts off (or would shut off if Tflo was not 4 or more). Editing also disables the idle timer.

SEt Flow-control

The "Flow-control" parameter is actually shorthand for two different parameters, one for TxD flow control and one for RxD flow control. The Tflo parameter is set to the new value, while the Rflo parameter is set to the new value modulo four.

If "Rflo" (# 12) is not equal to "Tflo" (# 5) modulo 4, then "Flow-control" will indicate "Mixed" instead of a number.

The default flow control for the Edit and Standard profiles is software, and for Transparent and Binary profile is hardware.

Although the DTR signal is not used for flow control when the flow control is software, it is used to disable or enable the RS-232 interface.

SEt Rflo, SEt Tflo

These commands show or set the flow control options for the RxD and TxD data lines.

Note that Tflo between 4 and 7 permits the prevention of overflow at the input buffer, but will permit undetected data overflow at the edit buffer, so the host/terminal must know that the edit buffer has room for what is sent to a circuit to prevent possible data loss.

Also note that auto-insertion of CR/LF can affect flow control slightly by virtue of any extra characters added to the edit buffer (inserted).

See the following table for RxD and TxD flow control options.

Rflo RxD meaning

- | | |
|---|--|
| 0 | (Tflo not 0): same as 1, except DTR disables serial interface while OFF.
(Tflo is 0): RTS/CTS flow control (RTS controls CTS/RxD, CTS may drop as needed to limit TxD). |
| 1 | XON/XOFF received on TxD enables / disables RxD, DTR is ignored. |
| 2 | XON/XOFF received on TxD enables/disables RxD, DTR signals DTE-Down while OFF, a restart is performed when DTR goes from OFF to ON (all circuits are reset). |
| 3 | DTR enables/disables RxD while ON/OFF. |
-

Tflo TxD meaning

- | | |
|---|--|
| 0 | (Rflo not 0): same as 1, except CTS is always OFF.
(Rflo is 0): RTS/CTS flow control (DTR enables / disables RxD and CTS, CTS will also go OFF as input buffer exceeds 191 characters, or the current edit buffer crosses the "full" mark, or the current circuit status is not operational). |
| 1 | XON/XOFF sent on RxD as input buffer exceeds 191 characters, or the current edit buffer crosses the "full" high-water mark (assuming the entire input will go to the current edit buffer), or the current circuit status changes, CTS is always ON (after power-up testing completed). |
| 2 | same as 1, except CTS reflects circuit Up/Down: CTS is OFF in data transfer mode during reset or remote-DTE-down, when the current circuit is not operational. |
| 3 | CTS changes as the input buffer exceeds 191 characters, or the current edit buffer crosses the "full" high-water mark (assuming the entire input will go to the current edit buffer), or the current circuit status changes, XON/XOFF is treated the same as any other data. |
| 4 | same as 0, except edit buffer and "full" mark are ignored. |
| 5 | same as 1, except edit buffer and "full" mark are ignored. |
| 6 | same as 2, except edit buffer and "full" mark are ignored. |
| 7 | same as 3, except edit buffer and "full" mark are ignored. |
-

SEt FOLd

If non zero, this parameter causes a <CRLF> to be inserted into the radio RxD output stream when the next character is a "printing" character, and the specified number of printing characters have already been output since the last <CR> was output on the RxD line.

SEt FOw

This parameter enables the transmission of the specified sets of characters to constitute a forwarding condition for all characters transmitted on the TxD line so far.

SEt Gard

This parameter controls the guard time interval for the plus-plus-plus and circuit switch commands.

SEt Idle

This parameter sets or disables the idle timer interval for idle based forwarding of data. The idle timer is disabled if the interval is set to zero or EDit is enabled.

SEt INtr

This parameter controls the intrude function, which differs with Echo off or on. With Echo on, INtr selects the degree to which echoed data and received data are kept apart. With Echo off, INtr selects whether received data is delivered from every circuit, each packet framed, or is delivered only from the current circuit, unformatted. Intrude frames data by preceding each packet with the user selected prefix and a two digit link number, and following each with the user selected suffix string.

SEt LDel

This parameter determines which character performs the line delete (or "cancel command") editing function.

SEt LF

Similar to CR, except applies to delivery of LF characters.

SEt MAsK

This parameter selects groups of characters which are not to be echoed when local echo is on.

SEt Mode

This parameter determines which mode is active at power up.

SEt Pad

This parameter selects the character (or selects "none") which is recognized as a PAD escape from data transfer mode command.

SEt PARI

This parameter determines whether parity is checked or ignored. (See the SUB parameter).

SEt PChr

This parameter selects the "plus" character for the plus-plus-plus escape command, and the command terminator equivalent to <CR> in the command mode.

SEt Ppp

This parameter enables or disables recognition of the plus-plus-plus escape command.

SEt Sigs

This parameter selects among several service signal options, including "suppressed". It also enables or disables local echo in the command mode.

SEt SUB

This parameter selects the character to be substituted for a TxD parity error, or disables substitution.

SEt TOss

This parameter enables or disables the discarding of all received data. If you enable TOSs, you never receive any data.

SEt TYPe

This parameter selects the type of editing service signals generated, or disables them. The correct value depends on the type of terminal or emulation being used.

SEt Wait

This parameter selects the page size for (or disables) the page wait function. This function allows a user to prevent more than one screen full of data from being delivered (and scrolling off of the display) until the user is finished with it.

Status

Status Commands (Subcommands)

The status command provides an indication of current packet and edit buffer input and output activity for any circuit. Status from a network controller shows information about all circuits configured for the network. Status from a remote radio shows information about the only circuit to the network controller.

These commands are available both in the command mode and in the data-transfer mode on circuit zero.

nn	show status, circuit number nn
' <text>	echo specified text (multidrop only)
%	show status, all circuits, binary form
*	show status, all circuits, tabular form
Battery	show battery status
Events	show event counters
Incoming	show incoming list
Outgoing	show outgoing list
Timer	show power-on timer
Zero	show event counters and reset to 0

The status subcommands (accessed in data transfer mode on circuit zero) utilize the same parameters as above, with the exception of nn and none (there is never a valid "current" circuit on circuit zero). Responses are the same. The use of circuit zero to access status subcommands is faster than escaping to the command mode and back, which is considered impractical for program use.

Note that a <CR> sent to circuit zero by itself (without a preceding subcommand word or letter) will return "ERR<CRLF>". The word "status" (or "s") by itself in the command mode returns the current circuit status, if there is a valid current circuit.

Status "

The optional quote subcommand (") echoes any text supplied following the quote in the command, and is only available with the "a" firmware version option. The text can be from 0 to 189 of any characters except CR.

Status % and Status *

The "*" status subcommand provides complete information for every circuit in the radio, but takes 16 characters per circuit (plus a heading line) to do so.

The "%" subcommand provides the same information as the "*" command in a compact one-character-per-circuit format (plus a CRLF).

An example of S * <CR> where three circuits exist is:

```

circ Rcv Snd engaged
 1 Net-Down
 2 0 2+
 3 0 1 -PAD-

```

The value of "Rcv" and "Snd" for a circuit is the number of packets awaiting transfer to the local terminal or remote modem in the receive and send queues. This can be up to two packets in each direction. If the circuit is not ready to transfer data, the cause is shown in place of the "Rcv" and "Snd" values.

The next character following the "Snd" value indicates the following about status of the edit buffer for that circuit, which may contain data not yet assembled into packets:

Char	Edit Buffer	TxD Flow Control
(blank)	Empty	Flow On
+	Not empty	Flow On
*	Nearly full	Flow Off
X	Full, next char discarded	Flow Off

The current PAD circuit is indicated by "-PAD-" being returned under the "engaged" column.

The "%" response is compared to the "*" response in the following table.

Note that "%" returns " - <CR> <LF>" if the quota is zero for the network controller (three chars, the first being "minus" or "dash").

Note also that when the character is "p" or greater (bits 4,5 and 6 are all 1) that the least significant bit (bit 0) indicates the presence of a service signal if set, and therefore the need to switch to that circuit (even if service signals are being suppressed).

This corresponds to a "*" response where the Rcv/Snd status contains the "-Sig" suffix.

N - The value of Quota for a network controller, or one for a remote modem.
 <CR> - Carriage Return character.
 <LF> - Line Feed character.
 x - Not specified, ignored, or don't care.
 z - Same as x above except that at least one bit z in char is zero.

		<--corresponding-->	
command:	* <CR>	% <CR>	
response:	N + 1 lines, where each line ends with <CR><LF>, the first line is a header, and the others numbered and ordered by circuit number. The number of chars per line can be 16, 21, or 22.	N + 2 chars, where the last two chars are <CR><LF> and the others are ordered by the corresponding circuit number. Each status char is a value from 48 to 122 (30h to 7ah).	
examples:	(ASCII)	(Binary)	(ASCII)
	circ Rcv Snd engaged	<none>	<none>
	xx x xx -PAD-	0 x x x x x x x	x
	xx Resetting x	0 1 1 1 0 0 0 0	p
	xx Reset-Sig x	0 1 1 1 0 0 0 1	q
	xx Net-Down x	0 1 1 1 0 0 1 0	r
	xx NetDwnSig x	0 1 1 1 0 0 1 1	s
	xx DTE-Down x	0 1 1 1 0 1 0 0	t
	xx DTEDwnSig x	0 1 1 1 0 1 0 1	u
	xx x x x	0 0 1 1 x x x x	0
	xx x x+ x	0 1 0 0 x x x x	@
	xx x x* x	0 1 0 1 x x x x	P
	xx x xX x	0 1 1 0 x x x x	'
	xx x 0x x	0 z z z 0 0 x x	0
	xx x 1x x	0 z z z 0 1 x x	4
	xx x 2x x	0 z z z 1 0 x x	8
	xx 0 xx x	0 z z z x x 0 0	0
	xx 1 xxx x	0 z z z x x 0 1	1
	xx 2 xx x	0 z z z x x 1 0	2
(minimum)	1 0 0	0 0 1 1 0 0 0 0	0
(maximum)	99 3 3X -PAD-	0 1 1 1 1 0 1 0	z
		(future)	

Note the following for the "%" ASCII column in the table:

- 1) These chars assume the "x" values (under the * columns) are at the minimum.
- 2) The values from "v" to "z" are reserved.

Write

Status Battery

This command displays 'Down' if the battery is low enough for the red lamp to flash, or 'Okay' otherwise. The response is six characters including a CRLF.

Status Events

The Events subcommand indicates the values of several internal event counters (such as character errors), and followed by a CRLF. The event counters reset to 65280 on the next count after reaching a maximum of 65535. The counts, in the order displayed, are:

1st	input (TxD) parity error, replaced w/ SUB (param #108)
2nd	input buffer overrun error (discarded characters)
3rd	input interrupt lost characters (UART buffer overrun, discarded)
4th	detected character framing errors (missing stop bits)
5th	received radio false start (modulation error before 1st char)
6th	received radio frame failures (format errors, etc.)
7th	received radio modulation error before end of frame
8th	received radio frame too long for current link size
9th	radio transmitted possible errors (correctable)
10th	edit buffer overrun (discarded characters)
11th	TxD frame overrun error
12th	received radio frame w/ bad CRC
13th	dynamic poll lost

Note that counters 1, 2, 3, 4, and 10 count errors which are NOT corrected by the radio.

Status Incoming

Display a list of any circuits having data or signals for local delivery. The numbers are separated by commas, or is a '-' if none, and followed by a CRLF.

Status Outgoing

Display a list of any circuits having data or signals to be transmitted to or acknowledged by the other end of the circuit. The numbers are separated by commas, or is a '-' if none, and followed by a CRLF.

Status Timer

The Timer subcommand indicates the number of seconds the radio has been operating (to two decimal places). At about 4/3 year the timer is reset to 1/3 year. This may be used as an alternate way to detect undesired power cycling of a radio (which causes circuit resets).

Status Zero

The status subcommand "Zero" has the same indication as the "Events" subcommand, and resets the counters to zero.

Parameters that have been changed during the session can be permanently stored and used as the default power-on condition when the unit is turned on again.

Enter the first letter of Baud, Facilities, or Profile, then type <CR>. This command requires a confirmation. Type Y for yes, any other character to abort the command. The command sequence is:

Write Baud

Writes the current Baud setting as the power-on default.

Write Facilities

Writes the current Facilities values as the power-on default.

Write Baud

Writes the current Profile of "PAD" parameters as the Initial Profile.

Note:

Care should be exercised in using the Write command automatically within an application program. If frequent configuration changes are needed by an application it is best to make those changes as needed, but not "Write" each change. The application software would therefore expect the most recent configuration to be lost when power is momentarily turned off.

The portable modem and Network controller use non-volatile memory to save the initial configuration settings for use at power-on. This type of memory does not depend on any continuous battery voltages to retain the settings. However, the maximum number of cycles is only specified to be ten thousand. (There is no limit on read cycles). This is more than enough when applied in a reasonable way. But using "Write" every minute, for example, could spend the ten thousand write cycles in less than a month (40 hour weeks).

A good rule of thumb would be that "Write" should not be executed as a built-in function of regular application software.

MULTIDROP OPERATION

Multidrop operation completely overrides Link Operation, and requires the terminals and/or computers to supply the radio protocol. If this is not what your system needs, see the Link Operation Section.

Multidrop operation can be enabled only in radios ordered with the "a" firmware version option. A radio using multidrop operation broadcasts data immediately as a terminal begins to send it. All terminals can receive all data. It is left up to the terminals to coordinate transmission timing and error correction. This capability is typical of ordinary twisted pair multidrop systems.

The concept of circuits, flow control, PAD interface, packets, error correction, and most of the configuration which is associated with radios using Link Operation disappears when using Multidrop Operation. (See figure 3).

Although multidrop operation is completely different from link operation, multidrop does use the PAD command mode interface of link operation for configuration functions.

Properties of Multidrop operation are as follows:

- A. The M2000T and M2000S have identical multidrop interfaces. The radios are not "controlling," and there is no built-in polling, however there is an inherent difference in power-supply capacity.
- B. All radio transmissions are directly and only instigated by the terminal. There are no autonomous radio transmissions such as built-in error correction acknowledgement or retransmission. The radio will ignore any perceived channel activity when the port instigates transmission. The radio cannot receive its own transmission.
- C. The network layer is disabled (no circuits, no circuit switching, etc.) and the radios instead operate in a broadcast fashion. All radios can deliver the same received data to their ports, but full and correct reception by each cannot be guaranteed.
- D. At a given instant, the radio receiver cannot reliably distinguish between ambient noise and user data, so some "noise" is expected to be delivered as user data, since link-level error detection is not provided.
- E. The omission of link-level error detection allows delivery of any received data to begin without waiting until the entire frame has arrived and been verified or condemned. But the receiver modulation-level detection remains:
 - 1) Detection of a modulation error prevents the reception and delivery of data following the questionable bit.
 - 2) Full data reception is expected to fail when more than one radio transmits at the same time (or one overlaps another).
 - 3) Longer data frames are more likely to be hit with an error, and therefore have a reduced effective range and coverage.
- F. The DTR signal:
 - 1) When the DTR signal is OFF:
 - The transmitter cannot be engaged.
 - The transmitter is shut off if it is already engaged.
 - All data sent to the port is ignored.
 - The transmit buffer is cleared (data is discarded).
 - Any received data is delivered to the port.
 - 2) When the DTR signal is ON:
 - Any data sent to the port is buffered. The buffer is a FIFO holding up to 255 characters, though more can be added as they are used. If buffer overflow occurs, buffer input is disabled until the buffer is exhausted.
 - The presence of buffered data engages the transmitter, and keeps it engaged until the data is exhausted, causing the transmitter to be turned off. This uninterrupted sequence is a frame. So data missing due to send-overflow or receive errors will always be at the "end" of delivered frames.
 - The absence of buffered data allows data to be received and delivered to the port.

- 3) The DTR signal is sampled every 10 ms and whenever data is sent to the serial port. A fast-response/slow-decay DTR filter is provided since:

Any ON sample is treated as ON.

Any 2 successive 10 ms OFF samples with no intervening serial input ON samples is treated as OFF.

G. The CTS signal:

- 1) The CTS signal is OFF while the radio is receiving and beginning to deliver data and while actively delivering data.
- 2) The CTS signal is OFF for at least 15/4800 seconds if at least one character is being delivered, but can go ON before delivery of the last character begins (4800 bps radios).
- 3) The CTS signal is ON while the radio is receiving no data.
- 4) The CTS signal is ON while the radio is transmitting.
- 5) The CTS signal momentarily switches OFF as frequently as noise appears to be possible detected data. (Frame reception aborts before the first character).
- 6) The CTS signal can optionally be wired to DTR to reduce the probability of collision of multiple transmitters for a non deterministic protocol (a protocol where multiple radios are not precluded from transmitting at the same time, or "colliding").

H. Data sent over the radio:

- 1) The data sent over the radio has a prefix character which is automatically added by the transmitter and stripped by the receiver, so is transparent. This prevents a remote in link operation from automatically responding to what could otherwise appear to be a poll, and reduces the probability of noise being mistaken for deliverable data.
- 2) The data sent over the radio has exactly eight bits per character (synchronous):

All 256 eight-bit data values are handled transparently.

No built-in parity, stop-bits, etc. are added.

If the radio ports are set to eight-bits/no-parity, and the user actually deals in seven-bit-with-parity data, then in fact the parity bits are actually sent across the radio.

If parity is used by the radio serial port, then the radio replaces any received serial character having bad parity with the SUBstitute character (1A hex) for transmission over the radio. Any received radio character-value higher than 127 will be delivered with "bad" parity if delivering 7 data bits with either odd or even parity.

Any trailing bits of data less than 8 bits are not delivered.

A 4800 bps (2400 bps) radio transmits 600 (300) characters per second.

- 3) The data sent over the radio is sent and delivered as soon as possible. With transmitter power-up settling time, and other overhead, the first character sent is delivered approximately 12 ms after being sent (4800 bps radios, does not include serial port transfer time, which depends on the respective serial port baud rates).

- I. The green lamp (send lamp) is on while the radio is transmitting, and is off while the radio is receiving. The usual association between flashing green and the presence of data is disabled.

- J. Configuration Commands for Multidrop Operation Each of the following two commands disables the other:

- 1) "Facilities Link Enable" provides the usual link operation where the network controller is a controller and a remote is controlled providing permanent virtual circuits for the attached terminal's, and disables Multidrop Operation. This is the default.
- 2) "Facilities Multidrop Enable" provides the Multidrop Operation and disables the usual Link Operation.

- K. *Modes.* The usual distinction between command-mode and data transfer mode (or communicate mode) also applies to Multidrop Operation. The communicate-mode is the initial mode at power-up if the "facilities" have been "written" with Multidrop operation enabled (overruling "Mode"). The "communicate" command is used (with no parameters) to switch from the command to the communicate-mode. The DTR signal is ignored in the command-mode. In the communicate-mode, while DTR is OFF, the sequence of three "plus" (PCh) characters sent to the serial port, preceded by at least one second (Gard time) of idle, followed by at least one second (Gard) of idle, and with less than one second (Gard) of idle between each character, will cause escape from the communicate-mode to the command-mode. While DTR is ON, this sequence cannot be recognized.
- L. *Multidrop Configuration.* The PAD profile has no effect on Multidrop Operation. There is no flow control, and there are no service signals (modem generated character strings) in the communicate-mode. The "Facilities Link" settings also have no effect. However, the baud command settings operate normally. The serial port should normally be set to a higher baud than the radio bit-rate, otherwise:
- 1) The transmitter will catch up with the data being sent to the serial port and "run-out" before the user finishes sending the frame, therefore having to restart and incur more overhead.
 - 2) The receiver cannot deliver data as fast as it is received, increasing the time before a given terminal can "turn around" a response.
 - 3) A separate 255 character FIFO buffer is used for receiving delivery. Delivery of a given frame will be terminated at the first character which overflows this buffer. This occurs for long frames if delivery is slow.

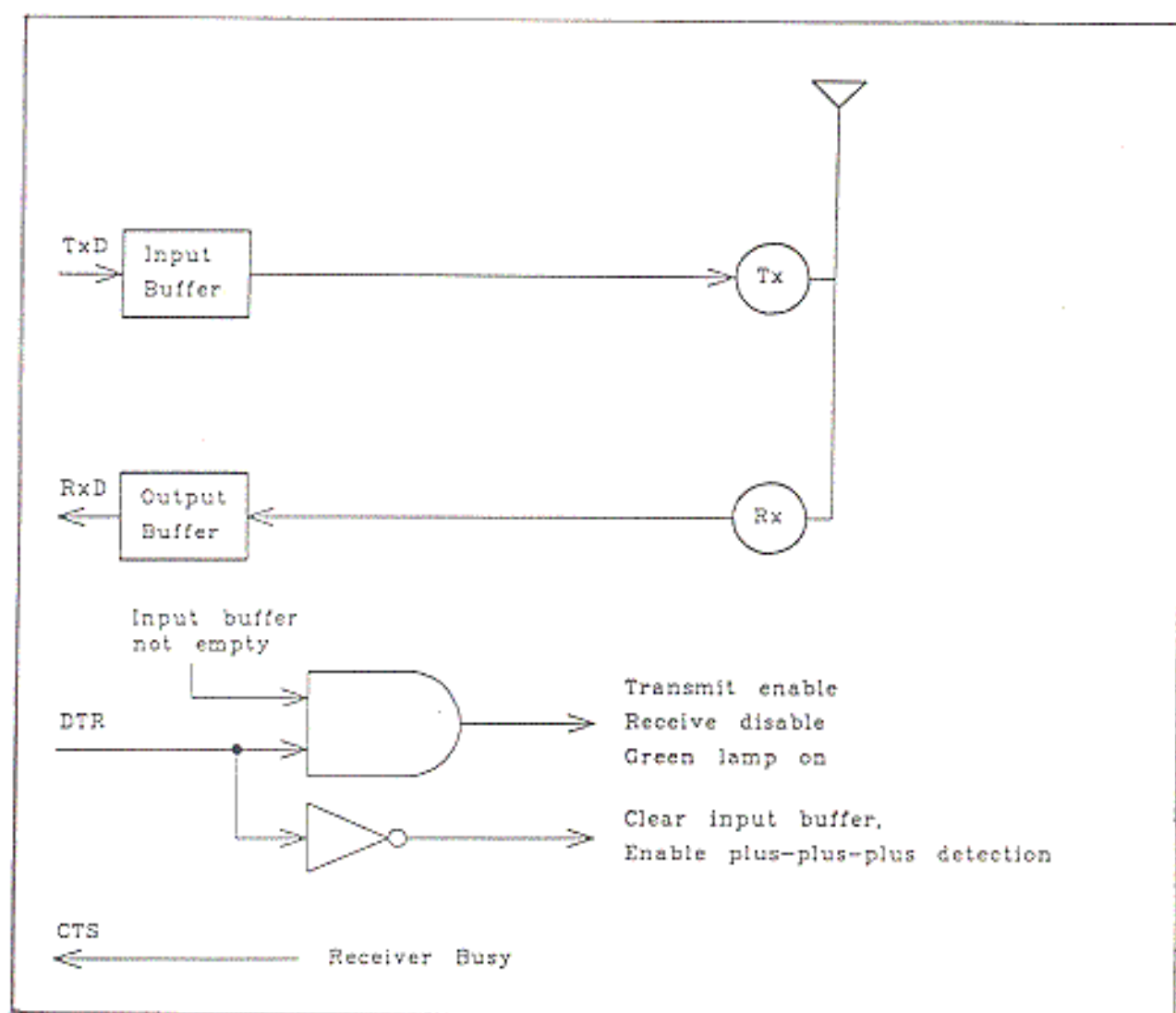

Figure 3
Radio in Multidrop Operation (Data Transfer Mode)

APPENDIX**SERVICE-SIGNAL LIST**

The following character strings can be generated by the radio and delivered to the terminal under the indicated conditions. The signals are preceded and/or followed by a CRLF pair unless otherwise explicitly indicated. Signals of the form <name> are indicated elsewhere by the name. All-caps names are ASCII control characters, e.g. <CRLF> is the Carriage-Return/Line-Feed signal. The items preceded by "*" are modified or new since version 2.0 (items 12, 16, 36, and 38).

#) name or conditions for generation
 service signal (one or more lines) <--- conditions (if any)

- 1) beep (response to error character when echo on):
 <BEL>
- 2) alert:
 <CRLF BEL CRLF>
- 3) title
- 4) notice:
 'Copyright (c) 1993, Monicor Electronic Corp,'
 'All Rights Reserved.'
- 5) test:
 'Modified: Mmm dd, yyyy, hh:mm:ss.'
- 6) factory:
 'Factory Data Failure'<BEL CRLF>
- 7) config:
 'Configuration Failure'<BEL CRLF>
- 7) rule:
 'Configuration Overrule'<BEL CRLF>
- 9) pwr-up (power-up in command-mode):
 <alert> <title> <notice>
 <alert> <--- only if unusual condition(s)
 <test> <--- unusual: if unreleased firmware.
 <factory> <--- unusual: if identity failure.
 <config> <--- unusual: if EEROM config error.
 <rule> <--- only if default-plug power-up
 <CRLF> <help> <--- omitted if unusual condition(s)
 <prompt>
- 10) prompt (command mode):
 '*'
 prompt (test mode):
 'Tx modulation: '
 prompt (write command mode):
 'Write initial values, Yes? '

Service-Signal List, Cont.

- 11) help:
- ```
'Commands:'
' Baud'
' Communicate'
' Default'
' Facilities'
' Help ?'
' Identify'
' Profile'
' Reset'
' REStart'
' SEt'
' Status'
' Write'
```
- \* 12) responses to Write command (to write power-on settings):
- ```
'Battery Too Low' <--- if battery too low to begin write.
'<verified>'      <--- if all data compares ok.
'X-error-X'      <--- if any data fails to compare.
'<factory>'      <--- if factory failure caused error.
```
- 13) fold (folds delivered lines when folding is used):
- ```
<CRLF>
```
- 14) page (waits for user before scrolling past page if page wait used, followed by a <fold> when resuming output):
- ```
<CR>'PAGE'
```
- 15) profile query responses (one of the following apply):
- ```
'Binary'
'Binary Modified'
'Editing'
'Editing Modified'
'Standard'
'Standard Modified'
'Transparent'
'Transparent Modified'
'Initial (Binary-mod)' (Initial is a modified
'Initial (Binary-mod) Modified' profile when written
'Initial (Editing-mod)' to the EEROM)
'Initial (Editing-mod) Modified'
'Initial (Standard-mod)'
'Initial (Standard-mod) Modified'
'Initial (Transparent-mod)'
'Initial (Transparent-mod) Modified'
```
- \* 16) responses to the SET command with no parameters (assumes Flow-ctrl)
- ```
'Flow-ctrl = 0 (RTS/CTS half-duplex)'
'Flow-ctrl = 1 (XON/XOFF)'
'Flow-ctrl = 2 (XON/XOFF w/ Fail)'
'Flow-ctrl = 3 (DTR/CTS)'
'Flow-ctrl = 4 (RTS/CTS half-duplex, ignore circ)'
'Flow-ctrl = 5 (XON/XOFF, ignore circ)'
'Flow-ctrl = 6 (XON/XOFF w/ Fail, ignore circ)'
'Flow-ctrl = 7 (DTR/CTS, ignore circ)'
```
- response to the SET Flow-ctrl command, depends on Rflo and Tflo value:
- ```
'Flow-ctrl = Mixed' <--- Rflo and Tflo do not correspond
'Flow-ctrl = n' <--- (where n is 0 to 7)
```

## Service-Signal List, Cont.

- 17) parameters (response to SET \* command, nnn is a 3-digit number with spaces for leading zeros, and aaaa is a parameter name with trailing spaces if less than 4 characters):  
 'nnn aaaa = nnn'
- 18) baud (where xxxx is speed, pppp is Even/Odd/Mark/Space/None, y is data-bits, and z is stop-bits)  
 'RS-232 set to xxxx bps, pppp y z'
- 19) response when numeric parameter is not a valid circuit, and n a number up to 5 digits):  
 'ERR: n Not A Circuit'
- 20) response when command is not currently supported:  
 '-Absent-'
- 21) identify frequency:  
 'Frequency: nnn.nnnnn MHz'
- 22) identify network ID number:  
 'Net ID #: nnnnn'
- 23) identify serial number:  
 'Serial #: nnnnn'
- 24) response to communicate command:  
 'nn' <--- only if nn not specified in command.  
 'COM'
- 25) response to Status Battery command:  
 'Okay' <--- if battery not low.  
 'Down' <--- if battery is low.
- 26) typical response to Status \* command for quota of 10:  
 'circ Rcv Snd engaged'  
 ' 1 DTEDwnSig '  
 ' 2 DTE-Down '  
 ' 3 NetDwnSig '  
 ' 4 Net-Down '  
 ' 5 Reset-Sig '  
 ' 6 Resetting '  
 ' 7 n nX -PAD- '  
 ' 8 n n\* '  
 ' 9 n n+ '  
 ' 10 n n '
- 27) pre (where <prefix> is Facilities Protocol Prefix characters):  
 <CRLF> <--- if "Sigs" 32 is disabled.  
 <prefix> <--- if "Sigs" 32 is enabled.
- 28) suf (where <suffix> is Facilities Protocol Suffix characters):  
 <CRLF> <--- if "Sigs" 64 is disabled.  
 <suffix> <--- if "Sigs" 64 is enabled.

## Service-Signal List, Cont.

- 29) reset and restart indication signals (where x is cause code and y is diagnostic code):
- ```

<pre>'RESTART x y'<suf>
<pre>'RESTART ERR y'<suf>      <--- equiv x=0
<pre>'RESTART LOAD y'<suf>     <--- equiv x=3
<pre>'RESTART UP y'<suf>      <--- equiv x=7
<pre>'RESET x y'<suf>
<pre>'RESET DTE-DOWN y'<suf>   <--- equiv x=1
<pre>'RESET RMT-ERR y'<suf>   <--- equiv x=3
<pre>'RESET ERR y'<suf>       <--- equiv x=5
<pre>'RESET LOAD y'<suf>      <--- equiv x=7
<pre>'RESET DTE-UP y'<suf>    <--- equiv x=9
<pre>'RESET NET-UP y'<suf>    <--- equiv x=15
<pre>'RESET NET-DOWN y'<suf>  <--- equiv x=29
<pre>'RESET DTE y'<suf>       <--- equiv x=0 or x>127

```
- 30) cause codes for reset & restart signals:
- ```

0 <--- restart, local procedure error: diag 17, 41.
3 <--- restart, network congestion.
7 <--- restart, network operational.
0 <--- reset, DTE originated reset/restart.
1 <--- reset, remote link out of order.
3 <--- reset, remote procedure error.
5 <--- reset, local procedure error.
7 <--- reset, network congestion.
9 <--- reset, remote DTE operational.
15 <--- reset, network operational.
29 <--- reset, network out of order.
128 to 255 <--- DTE originated reset/restart

```
- 31) diagnostic codes for reset & restart signals:
- ```

0 <--- no additional information.
17 <--- received restart confirmation (remote error).
27 <--- received reset confirmation (remote error).
28 <--- received non-reset during DTE reset request.
37 <--- REJECT not permitted.
41 <--- received restart with circuit number non-zero.
51 <--- reset indication time-out.
52 <--- restart indication time-out.
81 <--- improper DTE cause code.

```
- 32) response to "?" syntax help:
- ```

'<?>' <all valid possibilities separated by spaces>
<repeat of command response prior to ">?">

```
- 33) general syntax help possibilities:
- ```

'<char>' <--- one character expected
'<CR>' <--- <CR> or '+' expected
'<number>' <--- number expected
'<word>' <--- any word expected

```
- 34) command syntax error:
- ```

'ERR'

```
- 35) cancel-command response (delete line) when "Type" is not 0 or 2:
- ```

<prior command response> 'XXX'

```
- * 36) response to input/edit buffer overrun unless signals suppressed:
- ```

<pre>'ERR: TxD Buffer Overflow'<suf> <-- input buffer
<pre>'ERR: Edit Buffer Overflow'<suf> <-- edit buffer

```

## Service-Signal List, Cont.

- 37) REStart response if previous REStart still busy:  
 'ERR: Busy'
- \* 38) responses to Facilities Link command (q, n, s, b are numbers):  
 'Link Enabled' <--- if multidrop disabled  
 'Link Disabled' <--- if multidrop enabled  
 'Link Dynamic' <--- if dynamic polling enabled  
 'Link Quota: q' <--- if controller radio  
 'Link Number: n' <--- if portable radio  
 'Link Size: s'
- 39) responses to Facilities Multidrop command:  
 'Multidrop Disabled' <--- if link enabled  
 'Multidrop Enabled' <--- if link disabled
- 40) internal disassembly error (report to Monitor):  
 'ERROR ???'
- 41) attempt to set prefix or suffix to more than 8 characters:  
 'Excess Entries'
- 42) responses to Facilities Protocol command:  
 'Multidrop Enabled' <--- if link disabled  
 'PAD Interface' <--- if multidrop disabled.  
 'Packet Interface' <--- error, report to Monitor.  
 <tb> <--- error.
- 43) response when numeric parameter has illegal value:  
 'ERR: Invalid Number'
- 44) response to a PAD escape command:  
 <CRLF> 'PAD Commands:' <CRLF>
- 45) response to a break signal on TxD when "Brk" 4 is enabled:  
 'XXX-Brk-XXX'