

Monster Cable Products Inc.

Wireless MP3 adapter User guide

Setup Instructions:

The Monster model # 187047-00 Wireless MP3 adapter is your own personal FM broadcast station intended for use inside an automobile that has a 12v cigarette lighter outlet.

1. Plug the Monster Wireless MP3 adapter to your Apple Ipod* MP3 player's docking connector.
2. Plug the Monster car adapter to your automobile 12v cigarette lighter outlet.
3. Note Frequency displayed on Monster Wireless MP3 adapter. Tune your auto FM radio to same frequency.
4. Select an album on the Apple Ipod* MP3 player and push the playback button.
5. Adjust FM radio volume control to desired level.

For best results, preset the Monster MP3 adapter to FM frequencies that are not occupied by strong local FM broadcast stations.

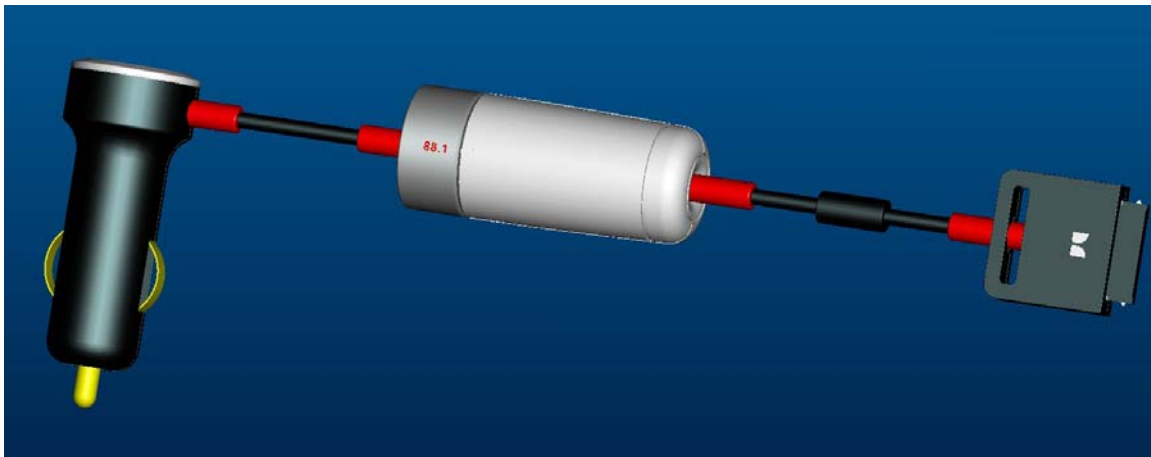

Instructions for changing frequency:

The Monster Wireless MP3 adapter contains eight (8) fixed frequency selections. The selected frequency is illuminated. To select among any of the 8 frequencies, twist the main body of the unit until the desired frequency is illuminated.

* Apple Ipod is a registered Trademark of Apple Computer, Inc.

Additional information is available at www.monstercable.com.

Warranty does not include malfunction caused by accident, misuse, contact with solvent chemicals or malfunction caused by tampering or modification. This warranty excludes all incidental or consequential damages. Some states do not allow the exclusion or limitation of consequential damages so the above limitation may not apply to you.

For Warranty Service, the product must be returned at your expense to place of purchase. Return policies may vary. If you cannot reasonably do this, please contact us stating the nature of the defect and date of purchase. Include a copy of your sales slip or proof of purchase. Your repaired or replacement equipment will be returned to you at our expense. This warranty gives you specific rights: you may also have other legal rights which vary from state to state.

FCC Notice: This device complies with Part 15 of the FCC rules. Operation is subject to the following two conditions: (1) this device may not cause harmful interference, and (2) this device must accept any interference received, including interference that may cause undesired operation. The installer of this radio equipment must ensure that the antenna is located or pointed such that it does not emit RF field in excess

of Health Canada limits for the general population; consult Safety Code 6, obtainable from Health Canada's website www.hc-sc.gc.ca/ Caution: changes or modifications not expressly approved by Monster Cable Products Inc. may void the users authority to operate this device.

Note: This equipment has been tested and found to comply with the limits for a class B digital device pursuant to Part 15 of the FCC rules. These limits are designed to provide reasonable protection against harmful interference in a residential installation. This equipment generates, uses, and can radiate radio frequency energy and, if not installed and used in accordance with the instructions, may cause harmful interference to radio communications. However, there is no guarantee that interference will not occur in a particular installation. If this equipment does cause harmful interference to radio or television reception, which can be determined by tuning the equipment off and on, the user is encouraged to try to correct the interference by one or more of the following measures:

- Reorient or relocate the receiving antenna
- Increase the separation between the equipment and receiver
- Connect the equipment into an outlet on a circuit different from that to which the receiver is connected
- Consult the dealer or an experienced radio/TV technician for help.

Monster Cable Products, Inc.

455 Valley Drive Brisbane, CA 94005

Phone 415-840-2000

FCC ID : RJE187047-00

IC: 5153A-18704700