

INSTRUCTION MANUAL

A preliminary draft of the User's Manual follows this page.
The text on the following three pages will be added to the user manual.

Specific Absorption Rate Data

This model wireless phone meets the government's requirements for exposure to radio waves.

Your wireless phone is a radio transmitter and receiver. It is designed and manufactured not to exceed limits for exposure to radio frequency (RF) energy set by the Federal Communications Commission (FCC) of the U.S. Government and by the Canadian regulatory authorities. These limits are part of comprehensive guidelines and establish permitted levels of RF energy for the general population. The guidelines are based on standards that were developed by independent scientific organizations through periodic and thorough evaluation of scientific studies. The standards include a substantial safety margin designed to assure the safety of all persons, regardless of age or health.

The exposure standard for wireless mobile phones employs a unit of measurement known as the Specific Absorption Rate, or SAR. The SAR limit set by the FCC and by the Canadian regulatory authorities is 1.6 W/kg.¹ Tests for SAR are conducted using standard operating positions accepted by the FCC and by Industry Canada with the phone transmitting at its highest certified power level in all tested frequency bands. Although the SAR is determined at the highest certified power level, the actual SAR

level of the phone while operating can be well below the maximum value. This is because the phone is designed to operate at multiple power levels so as to use only the power required to reach the network. In general, the closer you are to a wireless base station, the lower the power output.

Before a phone model is available for sale to the public in the U.S. and Canada, it must be tested and certified to the FCC and Industry Canada that it does not exceed the limit established by each government for safe exposure. The tests are performed in positions and locations (e.g., at the ear and worn on the body) reported to the FCC and available for review by Industry Canada. The highest SAR value for this model phone when tested for use at the ear is 0.54 W/kg, and when worn on the body, as described in this user guide, is 0.64 W/kg.²

While there may be differences between the SAR levels of various phones and at various positions, they all meet the governmental requirements for safe exposure. Please note that improvements to this product model could cause differences in the SAR value for later products; in all cases, products are designed to be within the guidelines.

SAR Data

Additional information on Specific Absorption Rates (SAR) can be found on the Cellular Telecommunications & Internet Association (CTIA) Web site:

<http://www.phonefacts.net>

or the Canadian Wireless Telecommunications Association (CWTA) Web site:

<http://www.cwta.ca>

1. In the United States and Canada, the SAR limit for mobile phones used by the public is 1.6 watts/kg (W/kg) averaged over one gram of tissue. The standard incorporates a substantial margin of safety to give additional protection for the public and to account for any variations in measurements.
2. The SAR information includes the Motorola testing protocol, assessment procedure, and measurement uncertainty range for this product.

FCC Notice To Users

Motorola has not approved any changes or modifications to this device by the user. Any changes or modifications could void the user's authority to operate the equipment. See 47 CFR Sec. 15.21.

This device complies with part 15 of the FCC Rules. Operation is subject to the following two conditions: (1) This device may not cause harmful interference, and (2) this device must accept any interference received, including interference that may cause undesired operation. See 47 CFR Sec. 15.19(3).

If your mobile device or accessory has a USB connector, or is otherwise considered a computer peripheral device whereby it can be connected to a computer for purposes of transferring data, then it is considered a Class B device and the following statement applies:

This equipment has been tested and found to comply with the limits for a Class B digital device, pursuant to part 15 of the FCC Rules. These limits are designed to provide reasonable protection against harmful interference in a residential installation. This equipment generates, uses and can radiate radio frequency energy and, if not installed and used in accordance with the instructions, may cause harmful interference to radio communications.

However, there is no guarantee that interference will not occur in a particular installation. If this equipment does cause harmful interference to radio or television reception, which can be determined by turning the equipment off and on, the user is

encouraged to try to correct the interference by one or more of the following measures:

- Reorient or relocate the receiving antenna.
- Increase the separation between the equipment and the receiver.
- Connect the equipment to an outlet on a circuit different from that to which the receiver is connected.
- Consult the dealer or an experienced radio/TV technician for help.



motorola **W270**

User's Guide

HELLOMOTO

Thanks for purchasing the Motorola W270 wireless phone! It's an affordable phone with a sleek design that's sure to get attention.

My Phone, My Way – It's your phone—make it that way. Customize your home screen with pictures, change wallpapers, and use your favorite song as your ringtone.

Convenient Extras – When you are away from your home or desk, make use of handy office tools like Calendar, Calculator, Stopwatch, and others.

Fun – When you have a little time to spare, play a game or listen to music.

Browse the Web – Use Web Access to do a little surfing on the go.

Here's a quick anatomy lesson.

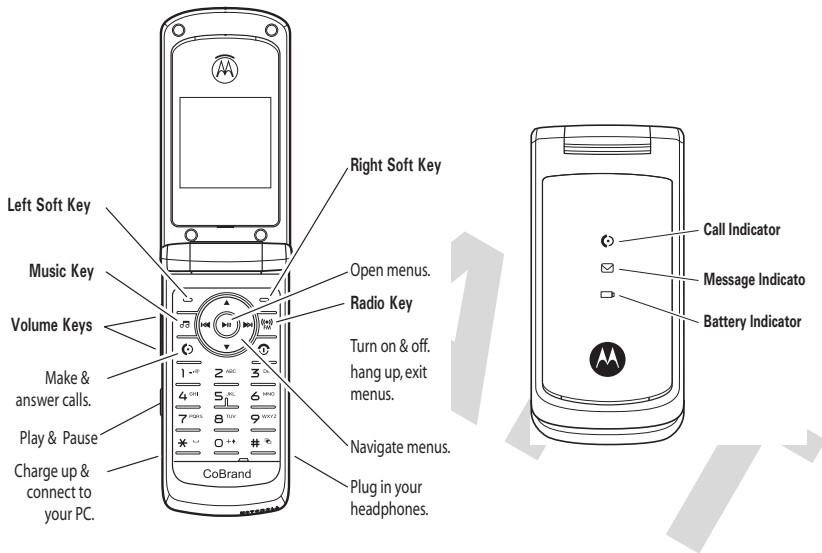

Home Screen

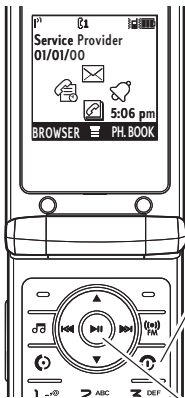

1 Press & hold the power key  until the display lights up, to turn on your phone.

2 Press the center key  to open the Main Menu.

Main Menu

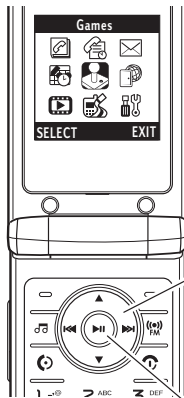

3 Press the navigation key  up/down/left/right to scroll to a menu feature.

4 Press the center key  to select it.

Motorola, Inc.
Consumer Advocacy Office
1307 East Algonquin Road
Schaumburg, IL 60196

www.hellomoto.com

1-800-331-6456 (United States)

1-888-390-6456 (TTY/TDD United States for hearing impaired)

1-800-461-4575 (Canada)

Certain mobile phone features are dependent on the capabilities and settings of your service provider's network. Additionally, certain features may not be activated by your service provider, and/or the provider's network settings may limit the feature's functionality. Always contact your service provider about feature availability and functionality. All features, functionality, and other product specifications, as well as the information contained in this user's guide are based upon the latest available information and are believed to be accurate at the time of printing. Motorola reserves the right to change or modify any information or specifications without notice or obligation.

MOTOROLA and the Stylized M Logo are registered in the US Patent & Trademark Office. All other product or service names are the property of their respective owners. The Bluetooth trademarks are owned by their proprietor and used by Motorola, Inc. under license. Microsoft, Windows and Windows Me are registered trademarks of Microsoft Corporation; and Windows XP is a trademark of Microsoft Corporation.

© Motorola, Inc. 2007.

Caution: Changes or modifications made in the radio phone, not expressly approved by Motorola, will void the user's authority to operate the equipment.

Software Copyright Notice

The Motorola products described in this manual may include copyrighted Motorola and third-party software stored in semiconductor memories or other media. Laws in the United States and other countries preserve for Motorola and third-party software providers certain exclusive rights for copyrighted software, such as the exclusive rights to distribute or reproduce the copyrighted software. Accordingly, any copyrighted software contained in the Motorola products may not be modified, reverse-engineered, distributed, or reproduced in any manner to the extent allowed by law. Furthermore, the purchase of the Motorola products shall not be deemed to grant either directly or by implication, estoppel, or otherwise, any license under the copyrights, patents, or patent applications of Motorola or any third-party software provider, except for the normal, non-exclusive, royalty-free license to use that arises by operation of law in the sale of a product.

Manual Number: 68XXXXX243-0

contents

menu map	7	tips & tricks	24	return a call	37
Safety Information	9	basics	25	caller ID	37
FCC Notice	13	home screen	25	speed dial	37
Use and Care	14	menu shortcuts	28	1-touch dial	38
EU Conformance	15	enter text	29	change active line	38
Recycling Information	16	handsfree speaker	32	entertainment	39
essentials	17	codes & passwords	32	FM radio	39
about this guide	17	lock & unlock phone	33	manage music library	40
battery tips	17	if you forget a code	33	manage pictures	42
SIM card	18	customize	34	use the web browser	42
install the T-Flash card	19	ring styles & alerts	34	play a game	43
install the battery	20	answer options	35	messages	44
charge the battery	21	wallpaper	35	send a message	44
turn it on & off	22	set screen saver	35	receive a message	44
make a call	22	backlight	35	voicemail	45
answer a call	22	calls	36	more messaging features	45
adjust volume	22	redial a number	36	other features	47
store a phone number	23	emergency calls	36	advanced calling	47
call a stored phone number	23	recent calls	36	phonebook	48
view your phone number	23	notepad	37	personalize	49

call times & data volumes . . .	51
handsfree	52
network	52
personal organizer	52
security	53
fun & games	54
TTY operation	54
SAR Data	56
WHO Information	57
Privacy and Data Security . . .	58
Driving Safety	59
Warranty	61
index	65

menu map

main menu



Phonebook

- [New Entry]



Recent Calls

- Received Calls
- Dialed Calls
- NotePad
- Call Times
- Call Cost*
- Data Times
- Data Volumes



Messages

- Create
- Inbox
- Draft
- Outbox
- Quick Notes
- Voicemail
- Browser Msgs
- Info Services
- MMS Templates



Office Tools

- Calculator
- MyMenu
- Alarm Clock
- Stop Watch
- Chat*
- Dialing Services
- STK*
- Calendar



Games

- Sudoku
- Tetris
- Sound Settings



WebAccess

- Start Browser
- Web Shortcut
- Go to URL
- Web Session
- Stored Pages
- History
- General Setting



Multimedia

- Pictures
- Music Library
- FM Radio



Personalize

- Home Screen
- Main Menu
- Color Setting
- Greeting
- Wallpaper
- Screen Saver
- Quick Dial*



Settings

(see next page)

*Network Dependent

This is the standard main menu layout.

Your phone's menu may be different.

settings menu



Easy Menu**



Ring Style

- Style
- Detail



Call Forward

- Voice Calls
- Fax Calls
- Data Calls
- Cancel All
- Forward Status



In Call Setup

- In-Call Timer
- Call Cost Setup*
- My Caller ID
- Answer Options
- Call Waiting
- Hearing Aid*



Initial Setup

- Time and Date
- 1-Touch Dial
- Balance Check**
- Display Settings
- Backlight
- Scroll
- Language
- DTMF*
- TTY Setup*
- Master Reset
- Master Clear
- Format Additional Storage Device



Phone Status

- My Numbers
- Active Line*
- Battery Meter



Headset

- Auto Answer



Network

- New Network
- Network Setup
- Avail. Networks
- My Network List*
- Service Tone
- Call Drop Tone
- Band Selection*



Security

- Phone Lock
- Fixed Dial
- Call Barring
- SIM PIN
- New Passwords



Easy Prefix*

- Auto Change
- Pref. Op

*Network Dependent

**Region Dependent

This is the standard main menu layout.

Your phone's menu may be different.

Safety and General Information

This section contains important information on the safe and efficient operation of your mobile device. Read this information before using your mobile device.*

Exposure to Radio Frequency (RF) Energy

Your mobile device contains a transmitter and receiver. When it is ON, it receives and transmits RF energy. When you communicate with your mobile device, the system handling your call controls the power level at which your mobile device transmits.

Your Motorola mobile device is designed to comply with local regulatory requirements in your country concerning exposure of human beings to RF energy.

Operational Precautions

For optimal mobile device performance and to be sure that human exposure to RF energy does not exceed the guidelines set forth in

* The information provided in this document supersedes the general safety information in user's guides published prior to May 1, 2007.

the relevant standards, always follow these instructions and precautions.

External Antenna Care

If your mobile device has an external antenna, use only a Motorola-supplied or approved replacement antenna. Use of unauthorized antennas, modifications, or attachments could damage the mobile device and/or may result in your device not complying with local regulatory requirements in your country.

DO NOT hold the external antenna when the mobile device is IN USE. Holding the external antenna affects call quality and may cause the mobile device to operate at a higher power level than needed.

Product Operation

When placing or receiving a phone call, hold your mobile device just like you would a landline phone.

If you wear the mobile device on your body, always place the mobile device in a Motorola-supplied or approved clip, holder, holster, case, or body harness. If you do not use a body-worn accessory supplied or approved by Motorola—or if you hang your mobile device from a lanyard around your neck—keep the mobile

device and its antenna at least 2.5 centimeters (1 inch) from your body when transmitting.

When using any data feature of the mobile device, with or without an accessory cable, position the mobile device and its antenna at least 2.5 centimeters (1 inch) from your body.

Using accessories not supplied or approved by Motorola may cause your mobile device to exceed RF energy exposure guidelines. For a list of Motorola-supplied or approved accessories, visit our Web site at: www.motorola.com.

RF Energy Interference/Compatibility

Nearly every electronic device is subject to RF energy interference from external sources if inadequately shielded, designed, or otherwise configured for RF energy compatibility. In some circumstances your mobile device may cause interference with other devices.

Follow Instructions to Avoid Interference Problems

Turn off your mobile device in any location where posted notices instruct you to do so.

In an aircraft, turn off your mobile device whenever instructed to do so by airline staff. If your mobile device offers an airplane mode or similar feature, consult airline staff about using it in flight.

Implantable Medical Devices

If you have an implantable medical device, such as a pacemaker or defibrillator, consult your physician before using this mobile device.

Persons with implantable medical devices should observe the following precautions:

- ALWAYS keep the mobile device more than 20 centimeters (8 inches) from the implantable medical device when the mobile device is turned ON.
- DO NOT carry the mobile device in the breast pocket.
- Use the ear opposite the implantable medical device to minimize the potential for interference.
- Turn OFF the mobile device immediately if you have any reason to suspect that interference is taking place.

Read and follow the directions from the manufacturer of your implantable medical device. If you have any questions about using your mobile device with your implantable medical device, consult your health care provider.

Driving Precautions

Check the laws and regulations on the use of mobile devices in the area where you drive. Always obey them.

When using your mobile device while driving, please:

- Give full attention to driving and to the road. Using a mobile device may be distracting. Discontinue use if you can't concentrate on driving.
- Use handsfree operation, if available.
- Pull off the road and park before making or answering a call if driving conditions so require.
- Do not place a mobile device in the airbag deployment area.

Responsible driving practices can be found in the “Smart Practices While Driving” section in this user’s guide and/or at the Motorola Web site: www.motorola.com/callsmart.

Note: The use of wireless phones while driving may cause distraction. Discontinue a call if you can't concentrate on driving. Additionally, the use of wireless devices and their accessories may be prohibited or restricted in certain areas. Always obey the laws and regulations on the use of these products.

Operational Warnings

Obey all posted signs when using mobile devices in public areas.







Potentially Explosive Atmospheres

Areas with potentially explosive atmospheres are often but not always posted and can include fueling areas such as below decks on boats, fuel or chemical transfer or storage facilities, or areas where the air contains chemicals or particles, such as grain dust, or metal powders.

When you are in such an area, turn off your mobile device, and do not remove, install, or charge batteries. In such areas, sparks can occur and cause an explosion or fire.

Symbol Key

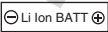
Your battery, charger, or mobile device may contain symbols, defined as follows:

Symbol	Definition
	Important safety information follows.
	Do not dispose of your battery or mobile device in a fire.
	Your battery or mobile device may require recycling in accordance with local laws. Contact your local regulatory authorities for more information.
	Do not throw your battery or mobile device in the trash.
	Your mobile device contains an internal lithium ion battery.
	Do not let your battery, charger, or mobile device get wet.

Symbol	Definition
	Listening at full volume to music or voice through a headset may damage your hearing.

Batteries and Chargers

Caution: Improper treatment or use of batteries may present a danger of fire, explosion, leakage, or other hazard. For more information, see the "Battery Use & Battery Safety" section in this user's guide.

Choking Hazards

Your mobile device or its accessories may include detachable parts, which may present a choking hazard to small children. Keep your mobile device and its accessories away from small children.

Glass Parts

Some parts of your mobile device may be made of glass. This glass could break if the product is dropped on a hard surface or receives a substantial impact. If glass breaks, do not touch or attempt to remove. Stop using your mobile device until the glass is replaced by a qualified service center.

Seizures/Blackouts

Some people may be susceptible to epileptic seizures or blackouts when exposed to flashing lights, such as when playing video games. These may occur even if a person has never had a previous seizure or blackout.

If you have experienced seizures or blackouts, or if you have a family history of such occurrences, please consult with your physician before playing video games or enabling a flashing-lights feature (if available) on your mobile device.

Discontinue use and consult a physician if any of the following symptoms occur: convulsion, eye or muscle twitching, loss of awareness, involuntary movements, or disorientation. It is always a good idea to hold the screen away from your eyes, leave the lights on in the room, take a 15-minute break every hour, and stop use if you are very tired.

Caution About High Volume Usage



Listening at full volume to music or voice through a headset may damage your hearing.

Repetitive Motion

When you repetitively perform actions such as pressing keys or entering finger-written characters, you may experience occasional discomfort in your hands, arms, shoulders, neck, or other parts of your body. If you continue to have discomfort during or after such use, stop use and see a physician.

FCC Notice to Users

The following statement applies to all products that have received FCC approval. Applicable products bear the FCC logo, and/or an FCC ID in the format FCC-ID:xxxxxx on the product label.

Motorola has not approved any changes or modifications to this device by the user. Any changes or modifications could void the user's authority to operate the equipment. See 47 CFR Sec. 15.21.

This device complies with part 15 of the FCC Rules. Operation is subject to the following two conditions: (1) This device may not cause harmful interference, and (2) this device must accept any interference received, including interference that may cause undesired operation. See 47 CFR Sec. 15.19(3).

If your mobile device or accessory has a USB connector, or is otherwise considered a computer peripheral device whereby it can be connected to a computer for purposes of transferring data, then it is considered a Class B device and the following statement applies:

This equipment has been tested and found to comply with the limits for a Class B digital device, pursuant to part 15 of the FCC Rules. These limits are designed to provide reasonable protection against harmful interference in a residential installation. This equipment generates, uses and can radiate radio frequency energy and, if not installed and used in accordance with the instructions,

may cause harmful interference to radio communications. However, there is no guarantee that interference will not occur in a particular installation. If this equipment does cause harmful interference to radio or television reception, which can be determined by turning the equipment off and on, the user is encouraged to try to correct the interference by one or more of the following measures:

- Reorient or relocate the receiving antenna.
- Increase the separation between the equipment and the receiver.
- Connect the equipment to an outlet on a circuit different from that to which the receiver is connected.
- Consult the dealer or an experienced radio/TV technician for help.

Use and Care

To care for your Motorola phone, please keep it away from:



liquids of any kind

Don't expose your phone to water, rain, extreme humidity, sweat, or other moisture. If it does get wet, don't try to accelerate drying with the use of an oven or dryer, as this may damage the phone.



extreme heat or cold

Avoid temperatures below 0°C/32°F or above 45°C/113°F.



microwaves

Don't try to dry your phone in a microwave oven.



dust and dirt

Don't expose your phone to dust, dirt, sand, food, or other inappropriate materials.



cleaning solutions

To clean your phone, use only a dry soft cloth. Don't use alcohol or other cleaning solutions.



the ground

Don't drop your phone.

European Union Directives Conformance Statement



Hereby, Motorola declares that this product is in compliance with:

The essential requirements and other relevant provisions of Directive 1999/5/EC
All other relevant EU Directives

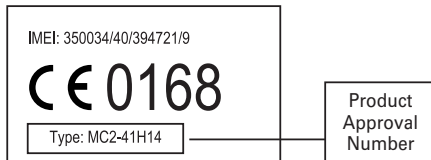

The above gives an example of a typical Product Approval Number.

You can view your product's Declaration of Conformity (DoC) to Directive 1999/5/EC (to R&TTE Directive) at www.motorola.com/rtte. To find your DoC, enter the product Approval Number from your product's label in the "Search" bar on the Web site.

Caring for the Environment by Recycling



This symbol on a Motorola product means the product should not be disposed of with household waste.





Disposal of your Mobile Telephone and Accessories

Please do not dispose of mobile telephones or electrical accessories, such as chargers or headsets, with your household waste. In some countries or regions, collection systems have been set up to handle waste electrical and electronic items. Please contact your regional authorities for more details. If no suitable scheme exists, you may return unwanted mobile telephones and electrical accessories to any Motorola Approved Service Centre in your region.

about this guide

Find it:  >  Recent Calls > Dialed Calls

This means that, from the home screen:

- 1 Press the *center key*  to open the main menu.
- 2 Press the *navigation key*  to scroll to **Recent Calls**, and press the center key  to select it.
- 3 Press the navigation key  to scroll to **Dialed Calls**, and press the center key  to select it.

symbols



This means a feature is network/subscription dependent and may not be available in all areas. Contact your service provider for more information.



This means a feature requires an optional accessory.

battery tips

Battery life depends on the network, signal strength, temperature, features, and accessories you use.

- Always use Motorola Original batteries and chargers. The warranty does not cover damage caused by non-Motorola batteries and/or chargers.
- New batteries or batteries stored for a long time may take more time to charge.
- When charging your battery, keep it near room temperature.
- When storing your battery, keep it uncharged in a cool, dark, dry place.



TM

- Never expose batteries to temperatures below -10°C (14°F) or above 45°C (113°F) during charging. Always take your phone with you when you leave your vehicle.
- It is normal for batteries to gradually wear down and require longer charging times. If you notice a change in your battery life, it is probably time to purchase a new battery.



Contact your local recycling center for proper battery disposal.

Warning: Never dispose of batteries in a fire because they may explode.

Before using your phone, read the battery safety information in the “Safety and General Information” section included in this guide.

To save battery life:

- Adjust the backlight to turn off more quickly (see page 35).
- Adjust the screen saver delay (see page 35).

SIM card

Your *Subscriber Identity Module* (SIM) card contains personal information like your phone number and phonebook entries.

SIM card installation

1

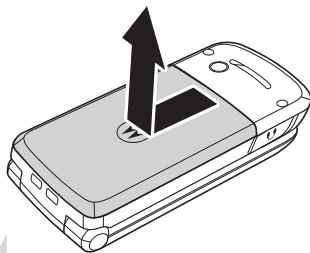

2

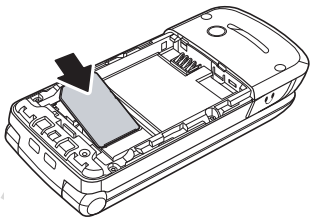

install the T-Flash card

A T-Flash card can be inserted to expand the memory of your phone.

1

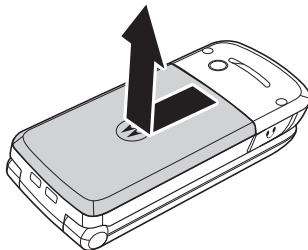

3

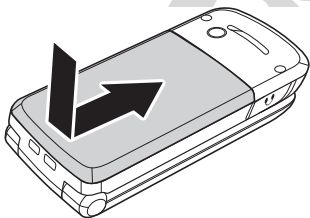

Caution: Do not bend or scratch your SIM card. Keep it away from static electricity, water, and dirt.

2

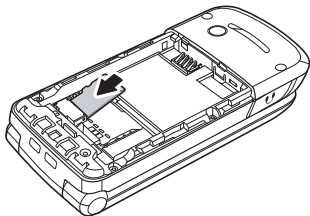

install the battery



1

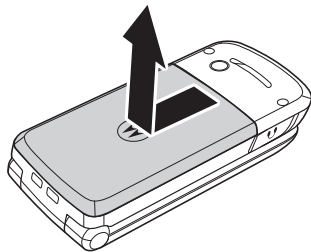

3

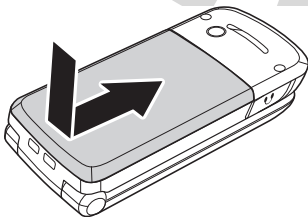

2

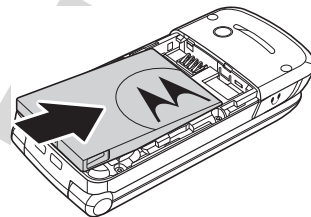

3

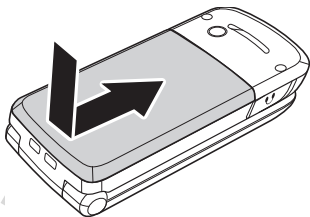

charge the battery

New batteries are shipped partially charged. Before you can use your phone, install and charge the battery as shown in the battery installation and battery charging sections. Some batteries perform best after several full charge and discharge cycles.



- 1 Insert the charger into the connector on your phone.
- 2 Plug the other end of the charger into an appropriate electrical outlet or a PC USB port. Driver software is required, which can be obtained at www.motorola.com/support.
- 3 When your phone displays **Charge Complete**, remove the charger.

Charging precautions: When charging your battery, keep it near room temperature. Never expose batteries to temperatures below 0°C (32°F) or above 45°C (113°F) when charging.

Important: Motorola mobile devices are designed to work best with qualified batteries. If you see a message on your display such as Invalid Battery or Unable to Charge, take the following steps:

- Remove the battery and inspect it to confirm that it bears a Motorola “Original Equipment” hologram;
- If there is no hologram, the battery is not a qualified battery;
- If there is a hologram, replace the battery and retry charging it;

- If the message remains, contact a Motorola Authorized Service Center.

Tip: Relax, you can safely leave the charger connected to the phone after charging is complete. This will **not** damage the battery.

turn it on & off

To turn your phone on, press and hold  for two seconds. If prompted, enter your four digit SIM card PIN code and/or unlock code.

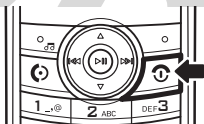

Caution: If you enter an incorrect PIN code three times in a row, your SIM card becomes disabled and your phone will display **SIM Blocked**. Contact your service provider.

To turn your phone off, press and hold  for two seconds.

make a call

Enter a phone number and press  to make a call.

To “hang up,” press .

answer a call

When your phone rings and/or vibrates, press  to answer.

To “hang up,” press .

You can also answer or end a call by pressing any key if the multi-key answer option is activated.

To change your answer option, see page 35.

adjust volume

Press  right or Volume key up to increase and left or Volume key down to decrease the earpiece volume during a call.

Tip: To mute a call, press  and select **Mute**. To unmute, press **UNMUTE**.

store a phone number

You can store a phone number in your **Phonebook**:

- 1 Enter a phone number in the home screen.
- 2 Press **Store**.
- 3 Enter a name and other details for the phone number. To select a highlighted item, press .

To edit or delete a **Phonebook** entry, see page 48.

call a stored phone number

Find it:  >  **Phonebook**

- 1 Scroll to the entry you want to call.
- 2 Press .

view your phone number







Find it:  >  **Settings** > **Phone Status** > **My Numbers**

To store or edit your name and number on your SIM card, press **View** while displaying it. If you don't know your phone number, contact your service provider.

Tip: Want to see your phone number while you're on a call? Press  > **My Tel. Number Line 1**.

tips & tricks

From the home screen (page 25), you can use the following shortcuts:

To...	Do this...
redial a number	Press  , then scroll to the number you want to call and press  again.
store a phone number	Enter a phone number, and press Store . Enter a name and other details for the phone number. Press Done to store the number and other entry information.
see recently-dialed numbers	Press  .
use application shortcuts	Press the left and right soft keys or the navigation key  .

To...	Do this...
1-touch dial a number	Press and hold the number key.
change ring style to vibrate	Press and hold  .

basics

home screen

The *home screen* displays when you are **not** on a call or using the menu.

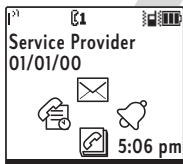

Left Soft Key
Label

Right Soft Key
Label

Note: Your home screen may look different than the screen shown here.

Soft key labels show the current soft key functions.

In the home screen, press  up, down, left, or right to open basic menu features. You can choose to show or hide home screen display icons:

Find it:  >  Personalize > Home Screen > Home Keys > Icons

status indicators

Status indicators can show at the top of the home screen.

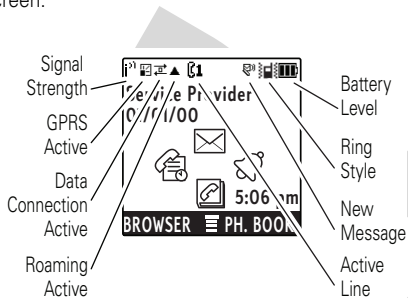

indicator

Signal Strength



Vertical bars show the strength of the network connection.





You cannot make or receive calls when  displays.







Note: If another network is available, you may be able to make emergency calls even when  displays.













GPRS

Indicates when your phone is using a high-speed GPRS network connection: 

-  = GPRS connection active
-  = GPRS attached
-  = GPRS available

indicator	
Data	Shows connection status:  = secure application connection  = <i>Circuit Switch Data</i> (CSD) call  = packet data transfer  = unsecure application connection
Roam	Shows when your phone is seeking or using a network outside of your home network.  <p>▲ = roaming</p>

indicator	
Active line	Indicates activity level of one or two lines (when 2 line SIM card is used):   = call connected (single line)  = call forward on (single line)  = active call on line 1  = active call on line 2  = line 1 active, call forward on  = line 2 active, call forward on

indicator	
Message	<p>Indicates when you receive new messages: </p> <p> = text message</p> <p> = voicemail message</p> <p> = voicemail & text message</p> <p> = MMS message</p> <p> = active chat session</p>
Ring style	<p>Indicates the ring style setting:</p> <p> = loud ring</p> <p> = soft ring</p> <p> = vibrate only</p> <p> = vibrate then ring</p> <p> = silent</p> <p> = vibrate and ring</p>

indicator	
Battery level	<p>Shows battery charge level. The more bars, the greater the charge.</p>

menu shortcuts

select home screen icon

Your phone displays four menu icons in the middle of the home screen.

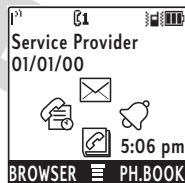

Press  left, right, up, or down to open the menu for the corresponding icon.

You can change the menu icons that appear in the home screen or set your phone not to display icons in the home screen:

Find it:  >  Personalize > Home Screen > Home Keys > Icons

select by number

You can set your phone to display the menu as a numbered list of features:

Find it:  >  Office Tools > MyMenu

When the menu is displayed as a numbered list, press the center key , then the number key associated with the menu feature you want to select.

enter text

Some features, such as messaging, allow you to enter text.

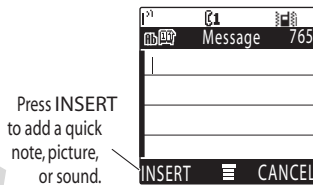

set entry modes

Multiple text entry modes make it easy for you to enter names, numbers, and messages. Press **#** in any text entry screen to select one of the following entry methods.

entry mode	
Primary	The primary text entry method (see below to set).
Numeric	Enter numbers only (see page 31).
Symbol	Enter symbols only (see page 31).
Secondary	The secondary text entry method (see below to set).

To set up Primary or Secondary entry mode:

- 1 Press **•••** > **Entry Setup** in any text entry view.
- 2 Select **Primary Setup** or **Secondary Setup**.
- 3 Select one of the following options:

entry method	
Tap	Enter letters and numbers by pressing a key one or more times (see page 31).
iTAP™	Let the phone predict each word as you press keys (see page 31).

iTAP™ mode

In any text entry screen, press **#** to switch entry modes until the **1** (if it is the primary entry mode) or **2** (if it is the secondary mode) appears. The iTAP software combines your key presses into common words, and predicts each word as you enter it. To use iTAP mode, it must be assigned as primary or secondary text entry mode (see page 30).

For example, if you press **2 7 7 5**, your phone displays a list of word combinations such as **Appl**, **Aspj**, and **Aspk**.

When you enter three or more characters in a row, your phone will guess the rest of the word.

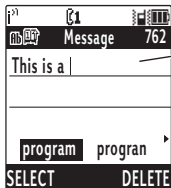

Press **SELECT** to accept **program**, or press **⬆** right to reject it and select another letter combination. Press ***** to enter a space after **program**.

tap mode

To enter text in tap mode, press a keypad key repeatedly to cycle through the letters and numbers on the keypad. Repeat this step to enter each letter. To use tap mode, it must be assigned as primary or secondary text entry mode (see page 30). In any text entry screen, press **#** to switch entry modes until the **1** (if it is the primary entry mode) or **2** (if it is the secondary mode) appears.

numeric mode

In any text entry screen, press **#** to switch entry modes until the **12** (numeric) indicator appears. Press keypad keys to enter the numbers you want.

symbol mode

In any text entry screen, press **#** to switch entry modes until the **@** (symbol) indicator appears. Press a keypad key to show its symbols at the bottom of the display.

Highlight the symbol you want and press **SELECT**.

delete letters & words

Place the cursor to the right of the text you want to delete, and then:

- Press **Delete** to delete one letter at a time.
- Press and hold **Delete** to delete all text.

handsfree speaker

You can use your phone's handsfree speaker to make calls without holding the phone to your ear.

To turn the speaker on during a phone call, press **SPKR ON**. To turn the speaker off, press **SPKR OFF**.

Note: The handsfree speaker does not work when your phone is connected to a handsfree headset.

codes & passwords

Your phone's four-digit **unlock code** is originally set to **1234** or to the last four digits of your phone number. The six-digit **security code** is originally set to **000000**.

Your service provider may reset these codes before you get your phone.

If your service provider didn't change these codes, you should change them to prevent others from accessing your personal information. The unlock code must contain four digits. The security code must contain six digits.

To change a code or password:

Find it:  >  **Settings** > **Security** > **New Passwords**

You can also change your **SIM PIN** or call barring passwords.

Select the type of code you want to change, enter the old code when prompted, then enter the new code.

If you forget your unlock code: At the **Enter Unlock Code** prompt, try entering **1 2 3 4** or the last four digits of your phone number. If that doesn't work, contact your service provider.

If you forget your security code, contact your service provider.

lock & unlock phone

You can lock your phone manually or set it to lock automatically whenever you turn it off.

To lock or unlock your phone, you need the four-digit unlock code. A locked phone still rings or vibrates for incoming calls or messages, **but you have to unlock it to answer.**

You can make emergency calls on your phone even when it is locked (see page 36).

To lock your phone:

Find it:  >  Settings > Security > Phone Lock > Lock Now or Automatic Lock

Enter the four-digit unlock code, then press **Ok**.

To unlock your phone:

When you see **Enter Unlock Code**, enter your four-digit unlock code and press **Ok**.

if you forget a code

Note: Your phone's four-digit unlock code is set at the factory to **1234** or to the last four digits of your phone number. The six-digit security code is set to **000000**.

If you forget your security code, contact your service provider.



customize

ring styles & alerts

Your phone rings and/or vibrates to notify you of an incoming call or another event, such as a new message. This ring or vibration is called an *alert*.

set a style

Find it:  >  **Settings** > **Ring Style**



- 1 Scroll to **Style** and press **Change** or .
- 2 Scroll to the desired ring style and press **Select** or .

set alerts

Your phone includes alerts for **Line 1** and **Line 2** (calls), **Text Msgs**, **Voicemail**, **Alarm**, **Key Volume**, and **Reminders**.

You can specify a detailed setting for each type of alert:

Find it:  >  **Settings** > **Ring Style**

- 1 Scroll to **Style Detail** and press **Change** or .
- 2 Scroll to the desired alert type and press **Change** or .
- 3 Scroll to the desired detail setting and press **Select** or .

Note: As you scroll through the settings, your phone plays a sample of each one you highlight.

answer options

You can use different ways to answer an incoming call.

Options	
Multi-key On	Answer by pressing any key.
Multi-key Off	Answer by pressing  .
Open to answer	Answer by opening the flip.

To turn on or turn off an answer option:

Find it:  >  Settings > In-Call Setup > Answer Options

wallpaper

Select a wallpaper (background) image in your home screen:

Find it:  >  Personalize > Wallpaper

set screen saver

You can set a photo, picture, or animation as a screen saver image. The screen saver image displays when no activity is detected for a specified time period:

Find it:  >  Personalize > Screen Saver

Tip: Turn off the screen saver to extend battery life.

backlight



Set the amount of time that the display and keypad backlights stay on.

Find it:  >  Settings > Initial Setup > Backlight

calls

redial a number



- 1 Press  from the home screen.
- 2 Scroll to the entry you want to call and press . If you hear a busy signal and see **Call Failed** or **Number Busy**, press  to redial the number.

emergency calls

Your service provider programs one or more emergency phone numbers (such as 112 or 911) that you can call under any circumstances, even if the SIM card is not inserted. You can dial and call the emergency number even when your phone is locked.

Note: Emergency numbers vary with different countries. Your phone's preprogrammed emergency number(s) may not work in all locations, and



sometimes an emergency call cannot be placed due to network, environmental, or interference issues.

To call the emergency number at any time:

- 1 Press the keypad keys to dial the emergency number.
- 2 Press  to call the emergency number.

recent calls

Your phone keeps lists of recent missed calls, dialed calls, and received calls. The lists are sorted from newest to oldest calls. The oldest calls are deleted as new calls are added.

Find it:  >  Recent Calls



Tip: Press  from the home screen to see the **Dialed Calls** list.

notepad

The most recent set of digits entered on the keypad are stored in your phone's notepad. These digits can be a phone number that you called or a number that you entered but did not call. To retrieve the number stored in the notepad:

Find it:  >  Recent Calls > Notepad

return a call

Find it:  >  Recent Calls

- 1 Highlight **Received Calls** or **Dialed Calls**, and press **SELECT**.
- 2 Highlight a call.
 - To call the number, press .
 - To see call details (like time and date), press **VIEW**.

caller ID

Calling line identification (caller ID) shows the phone number for an incoming call in your external and internal displays.

Your phone shows the caller's name when they're stored in your phonebook, or **Incoming Call** when caller ID information isn't available.

You can set your phone to play a different ringer ID for an entry stored in your phonebook.



To show or hide your phone number from the next person you call, enter the phone number and press  > **Hide ID/Show ID**.

speed dial

Each entry you store in the phonebook is assigned a unique *speed dial* number.

Tip: To see an entry's speed dial number, press  > **Phonebook**, scroll to the entry, and press **VIEW**.

To speed dial a number:

- 1 Enter the speed dial number for the entry you want to call.
- 2 Press  to submit the number.
- 3 Press  to call the number.

1-touch dial

To call speed dial entries 1 through 9, press and hold the single-digit speed dial number from the home screen.

Find it:  >  Settings > Initial Setup > 1-Touch Dial > Phone, SIM or Fixed Dial

change active line



If you have a SIM card for dual phone lines, you can change your line to make and receive calls from your other phone number:





Find it:  >  Settings > Phone Status > Active Line

FM radio

Find it:  >  **Multimedia** > **FM Radio**

Note: You can also press the FM key to enter FM radio function. A headset must be plugged in to activate the FM radio function. If you try to turn it on without inserting the earpiece, your phone will display **Please Insert The Earpiece.**

When the **FM Radio** is displayed:

- Press  or  left or right to adjust the frequency.
- Press  or Volume key up /down to adjust the volume.
- Press **OPTIONS** > **Mute** to mute the radio.
- Press  > **FM Radio Off** to turn the radio off.

Tip: Press **OPTIONS** > **Hide** to listen to the radio while you use other features.

use the radio presets

You can store up to nine preset radio stations.

- 1 Tune in the desired frequency by pressing  left or right or press **OPTIONS** > **Scan** to scan for all available radio stations. You can also use the keypad keys to enter a frequency by pressing **OPTIONS** > **Set Frequency**.

Tip: Press  to enter a decimal point.

- 2 Press and hold keypad keys to save that number as the preset.

select a radio preset

- 1 Press keypad keys to select the corresponding radio preset, or press **OPTIONS** > **Station Presets** to view a list of all radio presets.
- 2 Press  up or down to select a preset, then press **OPTIONS** > **Tune**.

send your radio presets

Share your favorite station with your friends and family!

Press **OPTIONS** > **Send Station Info.**

recording radio

You can record directly from the radio and play back recordings at a later time.

Press **OPTIONS** > **Record** to start recording.

Press **OPTIONS** > **Stop Recording** to stop recording.

select the radio output

You can play the radio through either a headset or a speaker. Simply press **OPTIONS** > **Use Speaker.**

When **Use Speaker** is selected, press **OPTIONS** > **Use Earpiece** to switch back to headset output.

Note: A headset must be plugged in to activate the FM radio function. If you try to turn it on without inserting the earpiece, your phone will display **Please Insert The Earpiece.**

manage music library

You can listen to all of the music library sounds stored on your phone or additional storage and assign the sound of your choice to alerts:

Find it:  >  **Multimedia** > **Music Library**

Scroll to the sound and press **Play** to listen to the sound.

Volume up/down: Press  or Volume key up/down to increase or decrease the volume.

Music rewind/choice: Press  right/left to select a sound and hold navi key left/right for 2sec. to rewind the sound.

Music pause: Press  or side key to pause the sound and option for other options.

selecting the storage device

Press **OPTIONS** > **View Storage Devices** > **Phone Memory** or **Memory Card** to select the storage device to play stored sounds from.

creating playlists

You can press Music key to enter music library and create a playlist from the music library sounds stored on your phone internal memory.

- 1 Press **•◂•** > **New** > **Playlist**
- 2 Scroll to **Name**, press **•◂•** and enter a name for your playlist.
- 3 Scroll to **Audio files**, press **•◂•** and select the audio files to add to the playlist.
- 4 When you have finished, press **DONE**. Press **DONE** again to save the playlist.

When using the T-Flash card:

- All music will be stored in "Sound" file.
- The "Create playlist" function is unavailable when using the T-Flash card.

applying music library sounds as ring tones

You can choose to apply any of the music library sounds stored on your phone as a ring tone.

- 1 Press **◂◂** up or down to select the sound you need, and press **•◂•** > **Apply as Ring Tone**.
- 2 Select **Line 1** or **Line 2** and press **SELECT** to assign the sound as your ring tone.

manage pictures

View the images stored on your phone and assign them to your wallpaper or screen saver:

Find it:  >  **Multimedia** > **Pictures**

Scroll to the image and press **VIEW** to see it, or press  for other options.

selecting the storage device

Press **OPTIONS** > **View Storage Devices** > **Phone Memory** or **Memory Card** to select the storage device to view stored pictures from.

use the web browser

start the browser

Find it:  >  **Web Access** > **Start Browser**

go to bookmarks

Bookmarks are shortcuts you can create to find a site that you like to visit frequently or use when you don't want to retype an address:

Find it:  >  **Web Access** > **Web Shortcut**

go to URL

Every website has a web address known as a URL. If you know the URL for the site you want to visit, you can enter the URL and go directly to it:

Find it:  >  **Web Access** > **Go to URL**

go to web session

Find it:  >  **Web Access** > **Web Session**

go to stored pages

Stored pages are similar to bookmarks, but the content of a stored page is saved to your phone memory:

Find it:  >  **Web Access** > **Stored Pages**

go to history

If you would like to return to a web site that you recently visited but did not create a bookmark for, you may be able to find it and return to it quickly by looking in your history list:

Find it:  >  Web Access > History

end web browser

Find it:  > OK

play a game

Find it:  >  Games

Tip: If you don't know how to play, press **Help** for instructions.

messages

You can send and receive SMS/EMS (text messages) and MMS (multimedia messages)





as well as access your voicemail from the **Messages** feature. Each message type allows you to attach different objects. The available options are displayed in the **Insert** menu.

Note: The maximum size of an MMS message is 100K with text, image, and audio. It supports images in gif format, and audio files in SP_Midi, Midi, and iMelody formats.



send a message

Find it:  >  **Messages** > **Create** > **SMS/EMS** or **MMS**

- 1 Enter the message text.
- 2 To insert a picture, animation, sound, quick notes, or contact info, press  > **Insert**.

- 3 To insert another slide in an MMS message, press  > **Insert** > **Add Slide**. You can enter more text and objects on the new page.
- 4 When you finish the message, press **OK**.
- 5 Choose one or more people for **Send To**.

receive a message

When you receive a message, your phone plays an alert and displays  or  (new message) indicator and a **New Message** notification.

Press **Read** to read the message immediately, or save it in your Message Inbox for viewing later.

To read messages in your Message Inbox:

Find it:  >  **Messages** > **Inbox**

- 1 Scroll to the message you want to read.

- 2 Press **READ** to open the message. For MMS messages, your phone displays the media object, then the message.

voicemail



Your network stores the voicemail messages you receive.

Note: Your service provider may give you additional information about using voicemail.

When you receive a voicemail message, your phone shows the voicemail message indicator and **1 New Message**. Press **CALL** to listen to the message.

To check your voicemail messages:









Find it:  >  Messages > Voicemail















or

Press and hold  from the home screen.

Note: Your device may prompt you to store your voicemail phone number. If you don't know your voicemail number, contact your service provider.









more messaging features





features
send a text message  >  Messages > Create > SMS/EMS
send a multimedia message  >  Messages > Create > MMS Note: MMS message size is restricted to 100 Kb or less.
send a quick note  >  Messages > Quick Notes
send a multimedia template message Create a message using a multimedia template with preloaded media:  >  Messages > Create > MMS Templates
read new message Read a new text or multimedia message: Press READ when the New Message notification displays.

features	
read old messages	
 >  Messages > Inbox	
read sent messages	
 >  Messages > Outbox	
edit drafts	
You can save messages to the Draft folder to edit later. To open the Draft folder:	
 >  Messages > Draft	
read browser messages	
 >  Messages > Browser Msgs	
info services	
Read messages from subscription-based services:	
 >  Messages > Info Services	
chat	
 >  Office Tools > Chat	

other features

advanced calling

features
conference call During a call, dial the next number and press  , then press Link . 
restrict calls Restrict outgoing or incoming calls: •  >  Settings > Security > Call Barring
enable or disable caller ID •  >  Settings > In Call Setup > My Caller ID
call waiting Change your call waiting notification and answering options: •  >  Settings > In Call Setup > Call Waiting

features
DTMF Tones Your phone can send <i>Dual Tone Multi Frequency</i> (DTMF) tones for calling card calls or other automated touch-tone calls. set up DTMF tones: •  >  Settings > Initial Setup > DTMF > Long DTMF or Short DTMF
create fixed dial list You can set up one or more numbers as your fixed dial list. •  >  Office Tools > Dialing Services > Fixed Dial Note: Maximum number of Fixed Dial entries is dependent on your SIM card.

phonebook

features

create entry

☛ > ☑ Phonebook > ☛ > New > Number

Enter details and press **DONE**.

view entry

☛ > ☑ Phonebook

Scroll to the entry or enter the first two letters of a name to show similar names.

call entry

☛ > ☑ Phonebook

View/select the entry, then press ☑.

edit entry

☛ > ☑ Phonebook

View/select the entry, then press ☛ > **Edit**.

features

turn fixed dial on/off

☛ > ⚙ Settings > Security > Fixed Dial

Note: Fixed dial is PIN2 protected. If you don't know your PIN2 code, contact your service provider.

quick dial

You can select up to three numbers for quick number dialing.

☛ > 🛠 Office Tools > Dialing Services > Quick Dial

turn on easy prefix auto change

☛ > ⚙ Settings > Easy Prefix > Auto Change

select carrier prefix

☛ > ⚙ Settings > Easy Prefix > Pref. Op

attach a number



Dial an area code or prefix for a phonebook number, press ☛ > **Attach Number**.





features
<p>delete entry</p> <p>☛ > ☑ Phonebook</p> <p>View/select the entry, then press ☛ > Delete.</p>
<p>copy entry</p> <p>☛ > ☑ Phonebook</p> <p>View/select the entry, then press ☛ > Copy > Entries > To.</p>
<p>copy multiple entries</p> <p>☛ > ☑ Phonebook</p> <p>View/select the entry, then press ☛ > Copy > Entries, press Change, highlight another entry, press ADD. Repeat as necessary.</p>
<p>sort entries</p> <p>☛ > ☑ Phonebook > ☛ > Setup > Sorting By > <i>sort order</i></p>

personalize

features
<p>change call volume</p> <p>☛ > ⚙ Settings > Ring Styles > <i>style</i> Detail > Ring Volume</p>
<p>change key volume</p> <p>☛ > ⚙ Settings > Ring Styles > <i>style</i> Detail > Key Volume</p>
<p>change color setting</p> <p>☛ > 🎨 Personalize > Color Setting</p>
<p>change greeting</p> <p>☛ > 🎨 Personalize > Greeting:</p>
<p>change scroll option</p> <p>Set the highlight bar to stop or wrap around in the menu lists:</p> <p>☛ > ⚙ Settings > Initial Setup > Scroll</p>
<p>change message alert</p> <p>☛ > ⚙ Settings > Ring Style > <i>style</i> Detail > <i>Text Msgs</i> or <i>Voicemail</i>.</p>

features
<p>change home screen soft keys</p> <p>📱 > 🛠️ Personalize > Home Screen > Home Keys > Left or Right soft key</p>
<p>change menu view</p> <p>Changes menu item order and selects whether the main menu uses icons or words.</p> <p>📱 > 🛠️ Personalize > Main Menu</p>
<p>use a custom menu</p> <p>Permits you to put your favorite features together on an easily-accessible menu.</p> <p>📱 > 🛠️ Office Tools > MyMenu</p>
<p>check battery meter</p> <p>📱 > ⚙️ Settings > Phone Status > Battery Meter</p>
<p>set the time and date</p> <p>📱 > ⚙️ Settings > Initial Setup > Time and Date</p> <p>Note: If you remove the battery for a long time, you may be prompted to reset the time and date.</p>

features
<p>turn on the service tone</p> <p>📱 > ⚙️ Settings > Network > Service Tone</p>
<p>turn on the call drop tone</p> <p>📱 > ⚙️ Settings > Network > Call Drop Tone</p>
<p>change the network band</p> <p>📱 > ⚙️ Settings > Network > Band Selection</p>
<p>view the network list</p> <p>📱 > ⚙️ Settings > Network > My Network List</p> 
<p>turn on the hearing aid feature</p> <p>If you use a hearing aid or have a cochlear implant, turn on the hearing aid feature to reduce RF interference:</p> <p>📱 > ⚙️ Settings > In Call Setup > Hearing Aid</p> 













features
<p>reset all phone options</p> <p>Reset all options except unlock code, security code, and lifetime timer, and clear all user settings and entries:</p> <p> >  Settings > Initial Setup > Master Reset</p>
<p>clear all phone options and data</p> <p>Reset all options except unlock code, security code, and lifetime timer:</p> <p> >  Settings > Initial Setup > Master Clear</p>

call times & data volumes

Network connection time is the elapsed time from the moment you connect to your service provider's network to the moment you end the call by pressing . This time includes busy signals and ringing.

The amount of network connection time you track on your resettable timer may not equal the amount of time for which you are billed by your

service provider. For billing information please contact your service provider directly.

features
<p>set in-call timer </p> <p> >  Settings > In Call Setup > In-Call Timer</p>
<p>view call times</p> <p> >  Recent Calls > Call Times</p>
<p>view data times</p> <p> >  Recent Calls > Data Times</p>
<p>view data volumes</p> <p> >  Recent Calls > Data Volumes</p>
<p>view call cost </p> <p> >  Recent Calls > Call Cost</p>

handsfree

Note: The use of wireless devices and their accessories may be prohibited or restricted in certain areas. Always obey the laws and regulations on the use of these products.

features

Turn speakerphone on/off

To turn the speakerphone on/off during a call, press **SPKR ON** or **SPKR OFF**.

turn on auto answer (headset)

Automatically answer calls when connected to a headset:

•◂ > 📞 Settings > Headset > Auto Answer

network

features

view and adjust current network settings

•◂ > 📞 Settings > Network

personal organizer

features

add calendar event

A title is required for a calendar event. All other information is optional.

•◂ > 📞 Office Tools > Calendar > Select > [New]

view calendar event

•◂ > 📞 Office Tools > Calendar

Scroll to the date, then press **SELECT**, then scroll to the name of the event and press **VIEW**.

set an event alarm

•◂ > 📞 Office Tools > Calendar

Scroll to the date, then press **SELECT**, then scroll to the name of the event and press •◂ > **Edit** > **Reminder**.

turn off the event alarm

Press **EXIT** or **VIEW**.

features

set alarm clock

⬅️ ➡️ > 🗄️ Office Tools > Alarm Clock

Select and edit an existing alarm or **[New Alarm]**, then select the alarm options and press **Done**.

turn off the alarm clock

Press **DISABLE** or **SNOOZE**. If you press **SNOOZE** the alarm will go off again in a few minutes.

access the calculator

⬅️ ➡️ > 🗄️ Office Tools > Calculator

convert currency

⬅️ ➡️ > 🗄️ Office Tools > Calculator

Press ⬅️ ➡️ > **Exchange Rate**, then enter a desired exchange rate and press **Ok**. Enter the amount of currency you want to convert, then press ⬅️ ➡️ > **Convert Currency**.

features

use the stop watch

⬅️ ➡️ > 🗄️ Office Tools > Stop Watch

Press **START** to start counting the time, press **STOP** to stop counting the time, and press **RESET** to reset the stopwatch.

Note: Press **SNAPSHOT** while timing to record up to 9 milestones without stopping the timer.







security

features

lock phone

⬅️ ➡️ > 🗄️ Settings > Security > Phone Lock

fun & games

features
manage sounds  >  Multimedia > Music Library
manage pictures  >  Multimedia > Pictures
play a game  >  Games

Note: Set the phone volume to level 4 (middle setting) for proper operation. If you experience a high number of incorrect characters, adjust the volume as needed to minimize errors.

Note: For optimal performance, your phone should be at least 12 inches (30 centimeters) from the TTY device. Placing the phone too close to the device may cause high error rates.

TTY operation



You can use an optional TTY device with your phone to send and receive calls. You must plug the TTY device into the phone's headphone jack and set the phone to operate in one of three TTY modes.

Note: Use a TSB-121 compliant cable (provided by the TTY device manufacturer) to connect the TTY device to the phone.

features

set TTY mode

 >  Settings > Initial Setup

Scroll to **TTY Setup** and press **Select**. Scroll to one of the following options and press **Select**.

Voice to use the standard voice mode.

TTY to transmit and receive TTY characters

VCO to receive TTY characters, but transmit by speaking into the phone microphone.

HCO to transmit TTY characters but receive by listening to the phone earpiece.

When your phone is in TTY mode, during an active call, your phone displays the international TTY mode, the international TTY symbol, and the mode setting.

return to voice mode

 >  Settings > Initial Setup

Scroll to **TTY Setup** and press **Select**. Scroll to **Voice** and press **Select**.

Specific Absorption Rate Data

This model meets international guidelines for exposure to radio waves.

Your mobile device is a radio transmitter and receiver. It is designed not to exceed the limits for exposure to radio waves recommended by international guidelines. These guidelines were developed by the independent scientific organization ICNIRP and include safety margins designed to assure the protection of all persons, regardless of age and health.

The guidelines use a unit of measurement known as the Specific Absorption Rate, or SAR. The ICNIRP SAR limit for mobiles devices used by the general public is 2 W/kg and the highest SAR value for this device when tested at the ear was ___ W/kg.¹ As mobile devices offer a range of functions, they can be used in other positions, such as on the body as described in this user guide.² In this case, the highest tested SAR value is ___ W/kg.¹

As SAR is measured utilizing the device's highest transmitting power, the actual SAR of this device while operating is typically below that indicated above. This is due to automatic changes to the power level of the device to ensure it only uses the minimum level required to reach the network.

While there may be differences between the SAR levels of various phones and at various positions, they all meet the governmental

requirements for safe exposure. Please note that improvements to this product model could cause differences in the SAR value for later products; in all cases, products are designed to be within the guidelines.

The World Health Organization has stated that present scientific information does not indicate the need for any special precautions for the use of mobile devices. They note that if you want to reduce your exposure then you can do so by limiting the length of calls or using a "hands-free" device to keep the mobile phone away from the head and body.

Additional Information can be found on the websites of the World Health Organization (<http://www.who.int/emf/>) or Motorola, Inc. (<http://www.motorola.com/rfhealth>).

1. The tests are carried out in accordance with international guidelines for testing. The limit incorporates a substantial margin for safety to give additional protection for the public and to account for any variations in measurements. Additional related information includes the Motorola testing protocol, assessment procedure, and measurement uncertainty range for this product.
2. Please see the *Safety and General Information* section about body worn operation.

Information from the World Health Organization

Present scientific information does not indicate the need for any special precautions for the use of mobile phones. If you are concerned, you may want to limit your own or your children's RF exposure by limiting the length of calls or by using handsfree devices to keep mobile phones away from your head and body.

Source: WHO Fact Sheet 193

Further information: <http://www.who.int/peh-emf>

Privacy and Data Security

Motorola understands that privacy and data security are important to everyone. Because some features of your mobile device may affect your privacy or data security, please follow these recommendations to enhance protection of your information:

- **Monitor access**—Keep your mobile device with you and do not leave it where others may have unmonitored access. Lock your device's keypad where this feature is available.
- **Keep software up to date**—If Motorola or a software/application vendor releases a patch or software fix for your mobile device which updates the device's security, install it as soon as possible.
- **Erase before recycling**—Delete personal information or data from your mobile device prior to disposing of it or turning it in for recycling. For step-by-step instructions on how to delete all personal information from your device, see the section entitled "master clear" or "delete data" in this user's guide.

Note: For information on backing up your mobile device data before erasing it, go to www.motorola.com and then navigate to the "downloads" section of the consumer Web page for "Motorola Backup" or "Motorola Phone Tools."

- **Understanding AGPS**—In order to comply with emergency caller location requirements of the FCC, certain Motorola mobile devices incorporate *Assisted Global Positioning System* (AGPS) technology. AGPS technology also can be used in non-emergency applications to track and monitor a user's location—for example, to provide driving directions. Users who prefer not to permit such tracking and monitoring should avoid using such applications.

If you have further questions regarding how use of your mobile device may impact your privacy or data security, please contact Motorola at privacy@motorola.com, or contact your service provider.

Smart Practices While Driving

Drive Safe, Call SmartSM

Check the laws and regulations on the use of mobile devices and their accessories in the areas where you drive. Always obey them. The use of these devices may be prohibited or restricted in certain areas. Go to www.motorola.com/callsmart for more information.

Your mobile device lets you communicate by voice and data—almost anywhere, anytime, wherever wireless service is available and safe conditions allow. When driving a car, driving is your first responsibility. If you choose to use your mobile device while driving, remember the following tips:

- **Get to know your Motorola mobile device and its features such as speed dial and redial.** If available, these features help you to place your call without taking your attention off the road.
- **When available, use a handsfree device.** If possible, add an additional layer of convenience to your mobile device with one of the many Motorola Original handsfree accessories available today.
- **Position your mobile device within easy reach.** Be able to access your mobile device without removing your eyes from the road. If you receive an incoming call at an



inconvenient time, if possible, let your voice mail answer it for you.

- **Let the person you are speaking with know you are driving; if necessary, suspend the call in heavy traffic or hazardous weather conditions.** Rain, sleet, snow, ice, and even heavy traffic can be hazardous.
- **Do not take notes or look up phone numbers while driving.** Jotting down a “to do” list or going through your address book takes attention away from your primary responsibility—driving safely.
- **Dial sensibly and assess the traffic; if possible, place calls when your car is not moving or before pulling into traffic.** If you must make a call while moving, dial only a few numbers, check the road and your mirrors, then continue.
- **Do not engage in stressful or emotional conversations that may be distracting.** Make people you are talking with aware you are driving and suspend conversations that can divert your attention away from the road.
- **Use your mobile device to call for help.** Dial 911 or other local emergency number in the case of fire, traffic accident, or medical emergencies.*

- **Use your mobile device to help others in emergencies.** If you see an auto accident, crime in progress, or other serious emergency where lives are in danger, call 911 or other local emergency number, as you would want others to do for you.*
- **Call roadside assistance or a special non-emergency wireless assistance number when necessary.** If you see a broken-down vehicle posing no serious hazard, a broken traffic signal, a minor traffic accident where no one appears injured, or a vehicle you know to be stolen, call roadside assistance or other special non-emergency wireless number.*

* Wherever wireless phone service is available.

Motorola Limited Warranty for the United States and Canada

What Does this Warranty Cover?

Subject to the exclusions contained below, Motorola, Inc. warrants its telephones, pagers, messaging devices, and consumer and professional two-way radios (excluding commercial, government or industrial radios) that operate via Family Radio Service or General Mobile Radio Service, Motorola-branded or certified accessories sold for use with these Products ("Accessories") and Motorola software contained on CD-ROMs or other tangible media and sold for use with these Products ("Software") to be free from defects in materials and workmanship under normal consumer usage for the period(s) outlined below. This limited warranty is a consumer's exclusive remedy, and applies as follows to new Motorola Products, Accessories and Software purchased by consumers in the United States or Canada, which are accompanied by this written warranty:

Products and Accessories

Products Covered	Length of Coverage
Products and Accessories as defined above, unless otherwise provided for below.	One (1) year from the date of purchase by the first consumer purchaser of the product unless otherwise provided for below.
Decorative Accessories and Cases. Decorative covers, bezels, PhoneWrap™ covers and cases.	Limited lifetime warranty for the lifetime of ownership by the first consumer purchaser of the product.
Monaural Headsets. Ear buds and boom headsets that transmit mono sound through a wired connection.	Limited lifetime warranty for the lifetime of ownership by the first consumer purchaser of the product.

Products Covered	Length of Coverage
Consumer and Professional Two-Way Radio Accessories.	Ninety (90) days from the date of purchase by the first consumer purchaser of the product.
Products and Accessories that are Repaired or Replaced.	The balance of the original warranty or for ninety (90) days from the date returned to the consumer, whichever is longer.

Exclusions

Normal Wear and Tear. Periodic maintenance, repair and replacement of parts due to normal wear and tear are excluded from coverage.

Batteries. Only batteries whose fully charged capacity falls below 80% of their rated capacity and batteries that leak are covered by this limited warranty.

Abuse & Misuse. Defects or damage that result from: (a) improper operation, storage, misuse or abuse, accident or neglect, such as physical damage (cracks, scratches, etc.) to the surface of the product resulting from misuse; (b) contact with liquid, water, rain, extreme humidity or heavy perspiration, sand, dirt or the like, extreme heat, or food; (c) use of the Products or Accessories for commercial purposes or subjecting the Product or Accessory to abnormal usage or conditions; or (d) other acts which are not the fault of Motorola, are excluded from coverage.

Use of Non-Motorola Products and Accessories. Defects or damage that result from the use of Non-Motorola branded or certified Products, Accessories, Software or other peripheral equipment are excluded from coverage.

Unauthorized Service or Modification. Defects or damages resulting from service, testing, adjustment, installation, maintenance, alteration, or modification in any way by someone other than Motorola, or its authorized service centers, are excluded from coverage.

Altered Products. Products or Accessories with (a) serial numbers or date tags that have been removed, altered or obliterated; (b) broken seals or that show evidence of tampering; (c) mismatched board serial numbers; or (d) nonconforming or non-Motorola housings, or parts, are excluded from coverage.

Communication Services. Defects, damages, or the failure of Products, Accessories or Software due to any communication service or signal you may subscribe to or use with the Products Accessories or Software is excluded from coverage.

Software

Products Covered	Length of Coverage
Software. Applies only to physical defects in the media that embodies the copy of the software (e.g. CD-ROM, or floppy disk).	Ninety (90) days from the date of purchase.

Exclusions

Software Embodied in Physical Media. No warranty is made that the software will meet your requirements or will work in combination with any hardware or software applications provided by third parties, that the operation of the software products will be uninterrupted or error free, or that all defects in the software products will be corrected.

Software NOT Embodied in Physical Media. Software that is not embodied in physical media (e.g. software that is downloaded from the internet), is provided “as is” and without warranty.

Who Is Covered?

This warranty extends only to the first consumer purchaser, and is not transferable.

What Will Motorola Do?

Motorola, at its option, will at no charge repair, replace or refund the purchase price of any Products, Accessories or Software that does not conform to this warranty. We may use functionally equivalent reconditioned/refurbished/pre-owned or new Products, Accessories or parts. No data, software or applications added to your Product, Accessory or Software, including but not limited to personal contacts, games and ringer tones, will be reinstalled. To avoid losing such data, software and applications please create a back up prior to requesting service.

How to Obtain Warranty Service or Other Information

USA	Phones 1-800-331-6456 Pagers 1-800-548-9954 Two-Way Radios and Messaging Devices 1-800-353-2729
Canada	All Products 1-800-461-4575
TTY	1-888-390-6456
For Accessories and Software , please call the telephone number designated above for the product with which they are used.	

You will receive instructions on how to ship the Products, Accessories or Software, at your expense, to a Motorola Authorized Repair Center. To obtain service, you must include: (a) a copy of your receipt, bill of sale or other comparable proof of purchase; (b) a written description of the problem; (c) the name of your service provider, if applicable; (d) the name and location of the installation facility (if applicable) and, most importantly; (e) your address and telephone number.

What Other Limitations Are There?

ANY IMPLIED WARRANTIES, INCLUDING WITHOUT LIMITATION THE IMPLIED WARRANTIES OF MERCHANTABILITY AND FITNESS FOR A PARTICULAR PURPOSE, SHALL BE LIMITED TO THE DURATION OF THIS LIMITED WARRANTY, OTHERWISE THE REPAIR, REPLACEMENT, OR REFUND AS PROVIDED UNDER THIS EXPRESS LIMITED WARRANTY IS THE EXCLUSIVE REMEDY OF THE CONSUMER, AND IS PROVIDED IN LIEU OF ALL OTHER WARRANTIES, EXPRESS OR IMPLIED. IN NO EVENT SHALL MOTOROLA BE LIABLE, WHETHER IN CONTRACT OR TORT (INCLUDING NEGLIGENCE) FOR DAMAGES IN EXCESS OF THE PURCHASE PRICE OF THE PRODUCT, ACCESSORY OR SOFTWARE, OR FOR ANY INDIRECT, INCIDENTAL, SPECIAL OR CONSEQUENTIAL DAMAGES OF ANY KIND, OR LOSS OF REVENUE OR PROFITS, LOSS OF BUSINESS, LOSS OF INFORMATION OR DATA, SOFTWARE OR APPLICATIONS OR OTHER FINANCIAL LOSS ARISING OUT OF OR IN CONNECTION WITH THE ABILITY OR INABILITY TO USE THE PRODUCTS, ACCESSORIES OR SOFTWARE TO THE FULL EXTENT THESE DAMAGES MAY BE DISCLAIMED BY LAW.

Some states and jurisdictions do not allow the limitation or exclusion of incidental or consequential damages, or limitation on the length of an implied warranty, so the above limitations or exclusions may not apply to you. This warranty gives you specific legal rights, and you may also have other rights that vary from state to state or from one jurisdiction to another.

Laws in the United States and other countries preserve for Motorola certain exclusive rights for copyrighted Motorola software such as the exclusive rights to reproduce and distribute copies of the Motorola software. Motorola software may only be copied into, used in, and redistributed with, the Products associated with such Motorola software. No other use, including without limitation disassembly of such Motorola software or exercise of the exclusive rights reserved for Motorola, is permitted.

index

A

- active line 27
 - change 38
- alarm clock 53
- alerts 34
 - set 34
- answer a call 22, 35
- answer options 35
- attach a number 48
- auto answer 52

B

- backlight 35
- battery 17, 50
 - level indicator 28
- battery life
 - extending 18, 35
- browser 42
- browser message

read 46

C

- calculator 53
- calendar
 - add event 52
 - event alarm 52
 - view event 52
- call
 - answer 22
 - make 22
 - mute 22
 - return 37
- call a stored phone number 23
- call costs 51
- call phonebook entry 48
- call times 51
- call times & data volumes 51
- charge the battery 21

chat 46

- clear options and data 51
- codes & passwords 32, 33
- color setting 49
- conference call 47
- convert currency 53
- copy phonebook entry 49
- create phonebook entry 48
- currency convertor 53

D

- data times 51
- data volumes 51
- date
 - set 50
- delete letters & words 32
- delete phonebook entry 49
- drop tone 50
- DTMF tones 47

dual line 38

E

easy prefix 48
edit phonebook entry 48
emergency calls 36
enter text 29

F

fixed dial 47, 48
FM radio 39

G

games 43, 54

H

handsfree 32, 52
hearing aid 50
home screen 25

I

in-call timer 51
info services 46
install the battery 20
iTAP text entry mode 31

L

lock/unlock
phone 33, 53

M

make a call 22
master clear 51
master reset 51
menu key 2
menu map 7
menu shortcuts 28
menu view 50
message alert 49
messages 45
 receive 44
missed call 37
mute a call 22

N

navigation key 17
network band 50
network settings 52
notepad 37
numeric text entry mode 31

O

one-touch dial 24, 38

P

passwords 32
phonebook 48
 call entry 48
 copy entry 49
 copy multiple entries 49
 create entry 48
 delete entry 49
 edit entry 48
 sort entries 49
 view entry 48
pictures 42
place (make) a call 22

power key 2

Q

quick dial 48

R

radio 39

recent calls 24, 36

recycle 18

redial 24, 36

reset all phone options 51

restrict calls 47

return a call 37

ring style 34

set 34

ring style indicators 28

ring styles & alerts

change 24

roaming 27

S

safety information 9

safety tips 59

save (store) a phone number 23,
24

screen saver 35

scroll option 49

security code 32

send a message 44

service tone 50

set time and date 50

settings menu 8

shortcut 24

shortcuts

menu 28

SIM card 18

soft keys 2, 25, 50

sort phonebook entries 49

speed dial 37

status indicators 26

active line 27

battery level 28

data 27

message 28

ring style 28

roaming 27

signal strength 26

stop watch 53

store a phone number 23

symbol text entry mode 31

T

tap text entry mode 31

temperature 18

text entry 29

modes 30

text entry mode

iTAP 31

numeric 31

symbol 31

tap 31

t-flash card 19

time

set 50

TTY

operation 54

set mode 55

turn phone on & off 22

V

voicemail 45

volume

earpiece 22

key 49

ring 49

W

wallpaper 35

warranty 61

Y

your phone number 23

DRAFT

www.motorola.com



680XXXXX143-O