



MOTONAV™ GC450

Quick Start Guide





# HELLOMOTO

## welcome

Your MOTONAV™ GC450 Personal Navigation Device helps you find the best route with GPS accuracy.

- Get clear directions and spoken street names, and eliminate second guessing when making a turn.
- Make hands-free calls and to send text messages while paired with your Bluetooth® enabled phone.
- Locate your favorite restaurant, nearest bank, gas station, or see businesses and other locations along your route.
- Save time and fuel, and leave getting lost in the past.
- Use MotoExtras to check the weather, fuel prices, flight status, and to use Google® local search.
- Use voice prompted search powered by Bing 411 to find local businesses, stock quotes, movie times, sports, and news headlines.

We've crammed all the main features of your device into this handy guide, and in a matter of minutes you'll see just how easy it is to use.

So go on, check it out.

**Caution:** Before using your personal navigation device for the first time, please read the **important legal and safety** information in the back of this guide.

## more information

Download the user's guide: [www.motorola.com/motonav](http://www.motorola.com/motonav)

Check for software updates, and more:

[www.motorola.com/motoextras](http://www.motorola.com/motoextras)

## this guide

### symbols in this guide



This means a feature is network/subscription dependent, or that it depends on the hands-free profile support supported by your Bluetooth-enabled mobile phone.

Refer to your mobile phone manual for more information.



This means a feature needs an optional accessory.

# contents

---

welcome . . . . .	1	set favorite addresses . . . . .	14	travel charger . . . . .	22
more information . . . . .	1	Traffic . . . . .	14	<b>troubleshooting . . . . .</b>	<b>23</b>
this guide . . . . .	1	MotoExtras . . . . .	15	Support . . . . .	23
<b>your navigation device . . . . .</b>	<b>3</b>	VoiceSearch powered by		Bluetooth Support . . . . .	23
<b>charge up . . . . .</b>	<b>4</b>	Bing 411 . . . . .	16	check for new maps . . . . .	23
<b>mount it – dashboard . . . . .</b>	<b>5</b>	safety cameras . . . . .	16		
<b>mount it – windshield . . . . .</b>	<b>6</b>	<b>calls . . . . .</b>	<b>17</b>		
<b>going on foot? . . . . .</b>	<b>7</b>	receive calls . . . . .	17		
<b>set it up . . . . .</b>	<b>8</b>	make calls . . . . .	18		
sync your contacts . . . . .	9	make calls using contacts . . . . .	18		
change the volume . . . . .	9	while on a call . . . . .	18		
MultiView . . . . .	10	<b>messages . . . . .</b>	<b>19</b>		
<b>Speak &amp; Go . . . . .</b>	<b>12</b>	send text messages . . . . .	19		
<b>let's go . . . . .</b>	<b>13</b>	trusted contacts . . . . .	20		
find an address with EasySearch	13	<b>tips &amp; tricks . . . . .</b>	<b>21</b>		
set your home address . . . . .	13	<b>power &amp; charging tips . . . . .</b>	<b>22</b>		
		car charger . . . . .	22		

# your navigation device

*the important buttons and connectors*

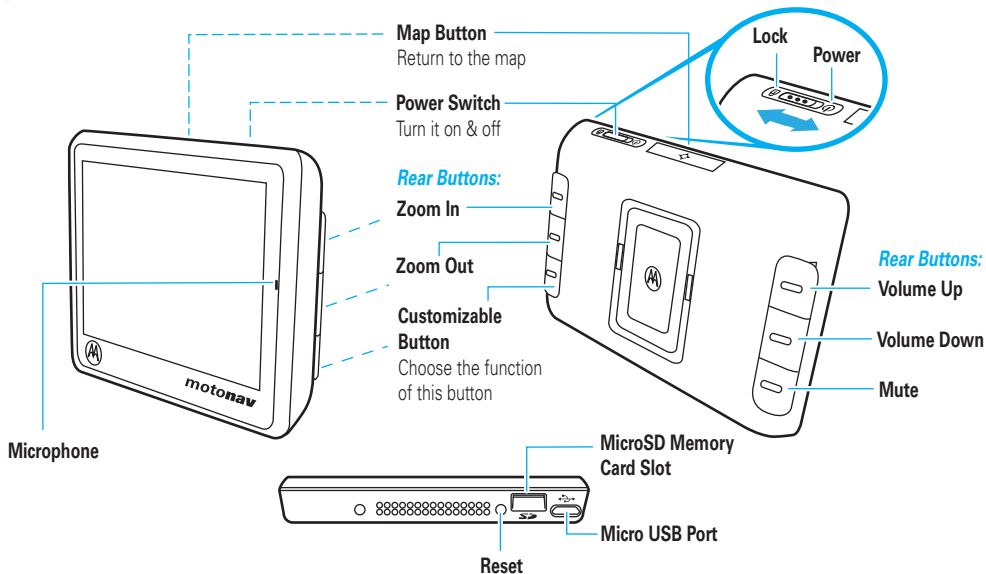

**Note:** You can choose which side you want for the rear button functions.

# charge up

*plug in to power up*

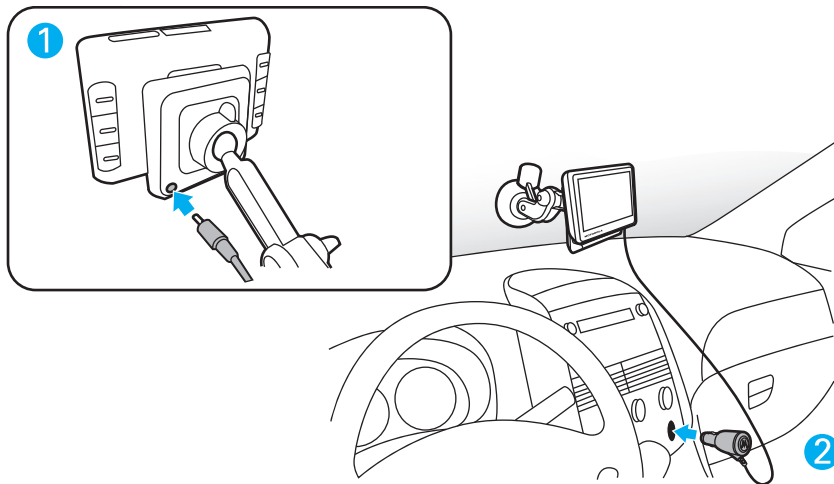

**Note:** Your battery is designed to last the life of the product. It should be removed only by a recycling facility. ANY ATTEMPT TO REMOVE OR REPLACE YOUR BATTERY WILL DAMAGE THE PRODUCT.

## mount it – dashboard

*put your device in your vehicle...or you can carry it when you leave your wheels behind*

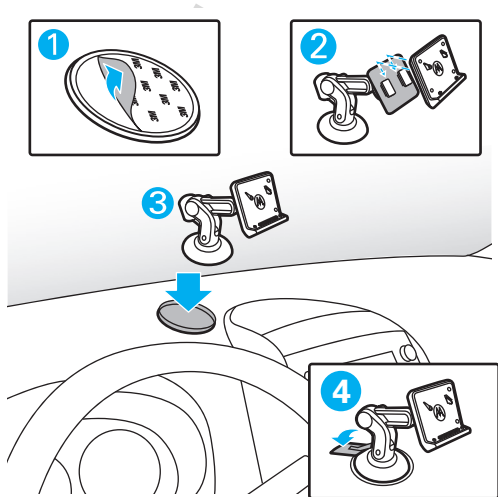

**Note:** Before you mount the device on the dashboard, clean the surface first. Put your device in a secure place. Do not cover an airbag. **DO NOT MOUNT WHERE DRIVER'S VISION IS OBSTRUCTED IN ANY WAY.** To mount your device on the windshield, see page "mount it – windshield" on page 6.

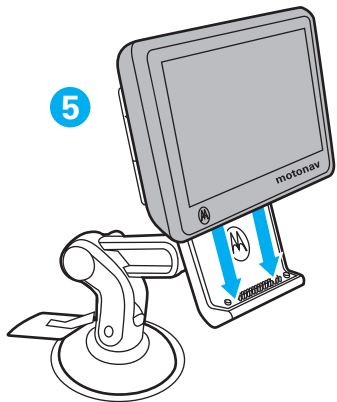

**Tip:** Align the posts on the cradle with the grooves on the back of the device. Listen for a small click when it attaches.

## mount it – windshield

The recommended location for a windshield mounted device is low and in the middle of the windshield in a manner that avoids impairing the driver's visibility. DO NOT MOUNT WHERE DRIVER'S VISION IS OBSTRUCTED IN ANY WAY.

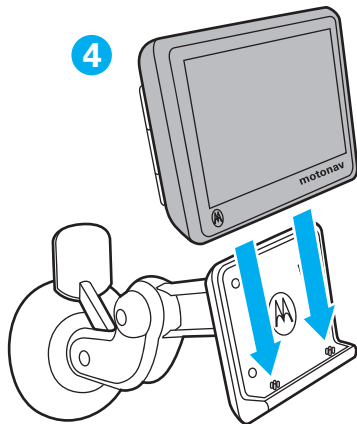
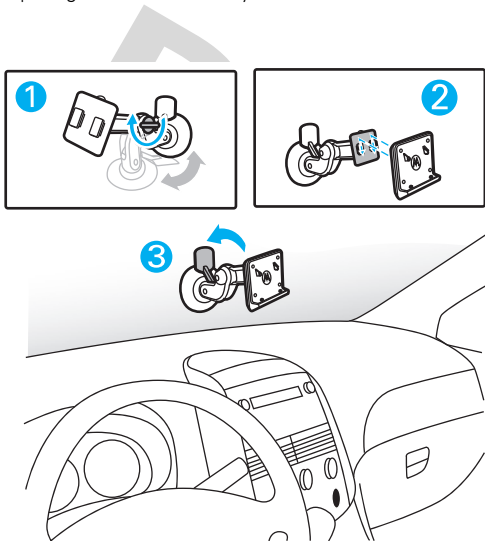

**Tip:** Align the posts on the cradle with the grooves on the back of the device. Listen for a small click when it attaches.



## going on foot?

To take your MOTONAV device with you, press the Release Button to remove it from the cradle.

- 1 Press to the Release Button (on bottom) remove device from cradle.

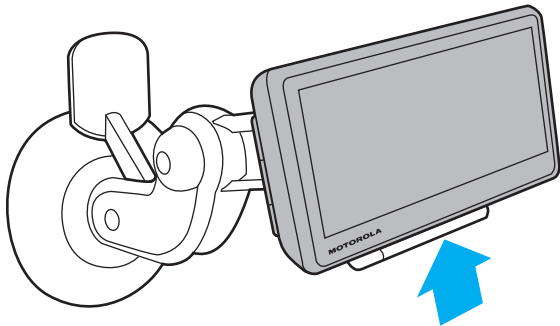

- 2 While holding the Release Button, lean the device forward.

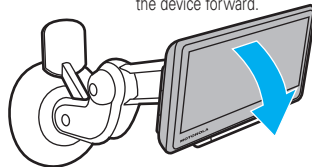

- 3 Lift the device up from the cradle.

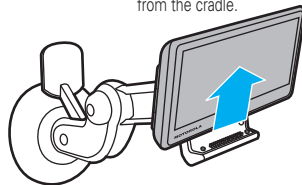

**Note:** When you take your MOTONAV device out of the cradle, tap **Enter Pedestrian Mode** to keep your device turned on while you walk. (You have the option of continuing on battery power, switching to pedestrian mode, or turning the device off.) If you don't select an option, your device turns off after 30 seconds.



## set it up

*let's get you up and moving*

### turn it on & off

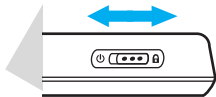
The Power Switch is located on the top of the device.



<b>turn on/off</b>	slide and release left (toward  )
<b>lock</b>	slide right (toward  ) (lock screen and rear buttons, but device stays on)

## set it up

When you first turn on your device, you'll need to do a couple things to set it up. You know, answer a few questions. Get to know each other.

- 1 Review or change the **Language**.
- 2 Review or change the **Time Zone**, **Distance Units**, and **Temperature Units**.
- 3 Optionally customize the buttons on the rear of the device.
- 4 Read and accept the Safety Warning.
- 5 Read and accept the End User License Agreement.
- 6 Connect your Bluetooth® enabled mobile phone. (Or see "connect it" on page 9 to connect later.)
- 7 Read the Traffic feature notice, if it appears.
- 8 Use your connected mobile phone to try MotoExtras.
- 9 Tap **Yes** for a tutorial or tap **No** to continue.
- 10 Tap **Done** to start using your device.

**Note:** To change these settings later, see your *User's Guide*.

## connect it

Connect your MOTONAV device with your phone using Bluetooth® wireless technology to use your device to make hands-free calls, send text messages (if supported by your mobile phone), or use MotoExtras or voice prompted search features.

- 1 Turn on your MOTONAV device.
- 2 On your device, tap the map, then tap **Main Menu > Settings > Bluetooth**.
- 3 Tap **On** to turn Bluetooth on. *discoverable* mode.
- 4 On your mobile phone, turn on the Bluetooth feature.
- 5 On your mobile phone, search for nearby devices.
- 6 Select the name of your MOTONAV device from the list of nearby devices found.  
**Tip:** To change the Bluetooth name of your MOTONAV device, go to **Main Menu > Settings > Bluetooth**, then scroll to **My Device**, tap the name to edit it.
- 7 Follow the directions on your mobile phone to connect to your MOTONAV device. If prompted for a passcode, enter **0000**.

**Note:** For more help connecting, visit [www.motorola.pairusa.com](http://www.motorola.pairusa.com).



## sync your contacts

After you connect with your mobile phone, you can download your contacts, recent call log, and text messages to your MOTONAV device.

Tap the map, then tap **Calling > Sync Phonebook, Sync Call Log, or Sync Messages**.

## change the volume

Adjust the volume during a call by pressing Volume Up or Volume Down on the back of the device (see page 3).

To mute, press Mute (see page 3).

To customize these buttons, tap the map, then tap **Main Menu > Settings > System > Customizable buttons**.

## MultiView

Your MOTONAV display has expandable left and right views. You can use these panels without ever leaving the map.

### map buttons

Tap the map to see these main features.

Search for an address or point of interest.

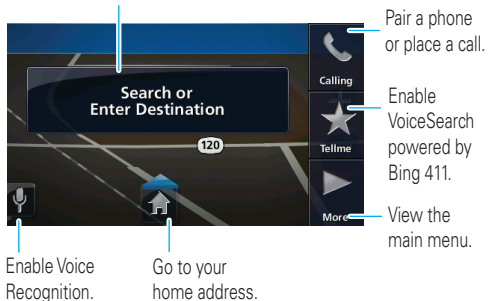

### right panel—main menu

Tap the map, then tap **Main Menu** to expand the right panel.

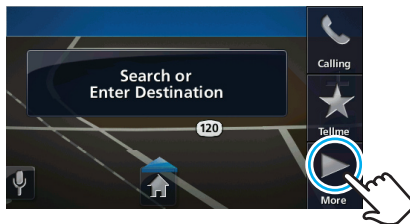

The main menu opens:

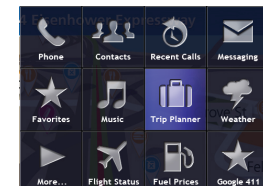

## left panel—not in a route

Tap the left panel to see information about your current location. To close the left panel, tap it.

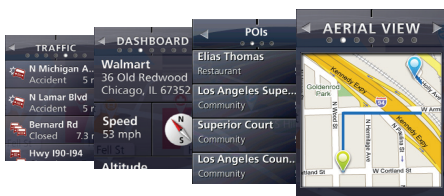

## left panel—in a route

Tap the left panel to see information about your route. To close the left panel, tap it.



# Speak & Go

*use your voice & keep your hands on the wheel*

Tap , then say these voice commands:

<b>voice commands</b> (say these when looking at the map screen)	"Dial Number"	"Main Menu"
	"Call Contact"	"Messages"
	"Call Information"	"Mute"/"Unmute"
	"Call Voicemail"	"Recent Calls"
	"Cancel Trip"	"Recent Trips"
	"Favorites"	"Send Location"
	"Go Home"	"Volume Up"
	"Help"	"Volume Down"
	"Locations"	"Where am I?"

<b>control commands</b> (say these for moving through screens)	"Back"
	"Cancel"
	"Page Up"
	"Page Down"

<b>global commands</b> (say these at any time)	"Read Out"
	"Repeat"
	"Exit"

**Voice Search powered by Bing 411** See page 16 for details.

# let's go

*hit the road, on wheels or on foot*

## find an address with EasySearch

Before you start driving, enter an address to create a route.

- 1 Tap the map.
- 2 Tap **Search** or **Enter Destination**.
- 3 To optimize your search results, specify the city you want to search within by tapping the box in the upper right and entering the city name.

If you don't enter a city, the search will return results for your current location.

- 4 Start entering a keyword or the street number and street name.

A list of matching addresses and points of interest appears on the right side of the screen.

**Tip:** To go to an intersection, enter the two street names separated by +.

- 5 Tap anywhere on the list to expand it.
- 6 Tap the address in the list.

An overview map appears along with options for the address you selected.

- 7 Tap **Go!**

## set your home address

- 1 Tap the map.
- 2 Tap **Main Menu**.
- 3 Tap **Favorites** > **Set Home**.
- 4 Tap **Current location** if you are at home, or tap **Enter location** to enter your home address.

**Tip:** The next time you want to go home, tap the map, then tap the home icon, and you're as good as there.

## set favorite addresses

After you select an address or point of interest, tap the name, then tap **Make Favorite** (at the bottom of the overview map).

To select a favorite, tap the map, then **Favorites** to see your saved addresses and points of interest.

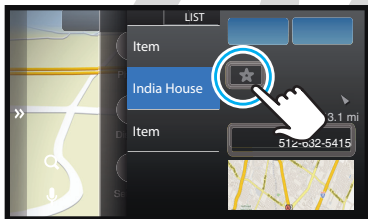

## Traffic

The Traffic service provides real-time traffic updates. When using the traffic service, your device calculates routes that minimize or avoid traffic delays. If traffic is detected on your route, your device offers you alternate routes to save you time. You can preview detours before accepting them.

Traffic information is included with MOTONAV device models numbers that end in "t" or with the purchase of a traffic upgrade kit.

Visit [www.motorola.com/motoextras](http://www.motorola.com/motoextras) for more information or to purchase Traffic Upgrade Kit for your device.

**Note:** Your device must be in the cradle and plugged in to the car charger to receive traffic information. The traffic receiver is located in the car charger.



## MotoExtras

Stay up on weather, flight status, and fuel prices. Your device includes 3 months free of MotoExtras, which you can renew online after your 3 months are up. Visit [www.motorola.com/motoextras](http://www.motorola.com/motoextras) to purchase MotoExtras for your device.

MotoExtras gives you these updates and features:

- weather
- fuel prices
- flight status
- Google® local search

**Note:** Your device must be connected to a Bluetooth® enabled mobile phone to receive information.

- 1 Tap the map.
- 2 Tap **Main Menu**.
- 3 Select **Weather, Flight Status, or Fuel Prices**.

## Google® local search

You can use Google to search for an address or point of interest. Your device must be connected to your mobile phone via Bluetooth to use this feature.

- 1 Tap **Search or Enter Destination**.
- 2 Enter what you want to search for.
- 3 Tap **Google > Search**.

## send addresses from the Web

MotoExtras also lets you send addresses from the internet to your device so you can navigate to them easily without entering the address. To use this feature, make sure your mobile phone is connected to your device via Bluetooth.

- 1 On your PC or mobile phone browser, navigate to [www.google.com/maps](http://www.google.com/maps).
- 2 Search for an address or business.
- 3 After you find what you're looking for, click **Send**.
- 4 Click **GPS**, then click **Motorola**.
- 5 Enter your mobile phone number, then click **Send**.

A text message is sent to your phone. The text message will include the options to **Call** or **Go** to this location.

## VoiceSearch powered by Bing 411

Use the voice prompted search service to find just about anything. This service searches for you, then sends your results to your phone in a text message.

- 1 Tap the map.
- 2 Tap **VoiceSearch**.

Your phone automatically dials to contact the voice prompt server. When prompted, say a search item:

- businesses (such as, “Joe’s Coffee Shop” or “coffee”)
- stock quotes
- entertainment (such as, “horoscopes” or “blackjack”)
- travel (such as, “taxi,” “airlines,” “hotels,” “rental cars,” or “local time”)
- news center
- sports
- popular shortcuts

## safety cameras

Your MOTONAV can warn you when approaching a speed camera, red light camera, or hazard area. Cameras appear as icons on the map.

You can:

- Set your MOTONAV to give you either audio or visual warnings, or both.
- Set the audio warning to be either a tone or a voice.
- Select warnings for speed cameras, red light cameras, or hazard areas.

Visit [www.motorola.com/motoextras](http://www.motorola.com/motoextras) to purchase the safety camera feature or to get software updates for your device.

# calls

## *it's good 2 talk*

First, connect your MOTONAV with your mobile phone (see page 9).

**Note:** Using a mobile device while driving may cause distraction. End a call if you can't concentrate on driving. Also, using a mobile device or accessory may be prohibited or restricted in certain areas. Always obey the laws and regulations on the use of these products.

## receive calls

When you receive a call, your device plays a ringtone and says, "Incoming call. Answer or ignore?"

To answer, say "Answer" or tap **Answer** on the display.



To ignore the call, say or tap **Ignore**.

To hang up, tap **End**.



## make calls

To make a call using Speak & Go, tap , then say "Dial Number," and follow the prompts.

Or, you can touch the screen to dial a call:

- 1 Tap the map.
- 2 Tap **Calling > Dial Pad**.
- 3 Enter the number and tap **Call**.

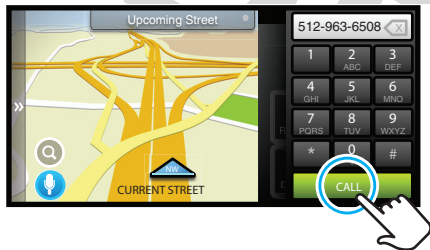

## make calls using contacts

- 1 Tap the map.
- 2 Tap **Main Menu > Contacts**.
- 3 Select a contact and tap the phone number to call.

## while on a call

While on a call, tap the map to minimize the phone controls.

**Tip:** Good at multitasking? You can use any feature other than Bluetooth® features while on a call.



To return to the phone controls, tap the phone bar.

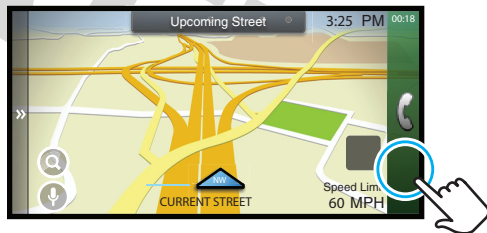

Here's what else you can do while you're on a call. But remember to keep your eyes on the road.

- **Mute** — Mute.
- **Talk on Phone** — Switch the conversation to your mobile phone so you can talk in private.
- **Talk on MOTONAV** — Switch your call to your navigation device.
- **Dial Pad** — Dial another number.
- **Recents** — View your call history.
- **Contacts** — Look up a contact.
- **End** — Hang up.

## messages

### *it's good 2 text*

If your mobile phone supports Bluetooth® messaging, you can use your MOTONAV device to send and receive messages. For more information about texting, see your *User's Guide*.

### send text messages

- 1 Tap the map, then tap **Main Menu > Messaging > Create Message**.
- 2 Select **Custom Message** to type a message, **My Location** to send your current location, or any of the pre-written text messages.
- 3 Tap **Send To**.
- 4 Select a contact.
- 5 Tap **Send**.

## trusted contacts



There are some people who always want to know where you are. With trusted contacts, you can let them know automatically.



- 1 Tap the map, then tap **Main Menu > Trusted Contacts**.
- 2 Tap **Location Share**.
- 3 Select a contact.
- 4 Tap **Always Ask** if you want the contact to know your location just this one time or **Always Allow** if it's OK to share your location with the contact always.

If your MOTONAV is connected with your mobile phone, you can automatically share your current location with a trusted contact when they text “**motonav**” to you. When you're not in a route, your current location is shared with your trusted contact. When in a route, you share your location, destination, and your estimated time of arrival (ETA).

## tips & tricks

*a few things to make you a pro*

To...	
<b>pick a destination from the map</b>	Press and hold the location on the map.
<b>repeat the last instruction</b>	Tap the arrow in the top left.
<b>find out what a map icon means</b>	Press and hold the icon.
<b>access MultiView panels</b>	Tap the left & right panels.
<b>zoom in or out</b>	Press the Zoom rear buttons (see page 3) or tap  or  on the map.
<b>access ads</b>	Tap the right panel, then tap <b>Main Menu</b> > <b>Offer Inbox</b> .

To...	
<b>start voice recognition</b>	Tap  .
<b>switch between 2D &amp; 3D view</b>	Tap  .
<b>reset your device</b>	Press and hold the Reset button (see page 3).
<b>use voice search</b>	Tap <b>Voice Search</b> to access services powered by Bing 411.

# power & charging tips

## *stay powered up*

**Note:** You can find the battery level indicator by expanding the left panel and looking on the dashboard.

## car charger

Power your device by using the included car charger.

- When you insert your device into the cradle, it turns on automatically if the charger is plugged in, has power, and the power switch is not in the locked position.
- When you remove your device from the cradle or disconnect the power, it gives you the option of continuing on battery power, switching to pedestrian mode, or turning the device off. If you don't select an option, your device turns off after 15 seconds.
- If you leave the device off for more than four days, it enters a power saving mode and will take a few moments longer to start up next time.
- When operating on battery power, the power light flashes red when the battery is low.
- The included car charger will not power Motorola mobile phones.

## travel charger

If your navigation device kit includes a micro USB wall charger, you can use it to charge your device.

- Turn off your navigation device before using the travel charger. (Your navigation device consumes more power when turned on than the wall charger can provide.)
- You can also connect your navigation device to a computer using a micro USB cable to charge it. Turn your device off before charging it via a USB connection.
- You can use the travel charger to charge any mobile phone that has a micro USB port.



# troubleshooting

*we're here to help*

## Support

To download new software, update your maps, purchase additional accessories, or get help, visit

[www.motorola.com/motoextras](http://www.motorola.com/motoextras).

To register your device, visit [www.motorola.com/motonav](http://www.motorola.com/motonav).

## Bluetooth Support

If you need more help, visit [www.motorola.com/Bluetoothsupport](http://www.motorola.com/Bluetoothsupport).

## check for new maps

Within the first 60 days of use, get a free map update by visiting [www.motorola.com/motoextras](http://www.motorola.com/motoextras). Terms and conditions apply. Subject to availability. Visit the Web site for details.

## Software Copyright Notice

Motorola products may include copyrighted Motorola and third-party software stored in semiconductor memories or other media. Laws in the United States and other countries preserve for Motorola and third-party software providers certain exclusive rights for copyrighted software, such as the exclusive rights to distribute or reproduce the copyrighted software. Accordingly, any copyrighted software contained in Motorola products may not be modified, reverse-engineered, distributed, or reproduced in any manner to the extent allowed by law. Furthermore, the purchase of Motorola products shall not be deemed to grant either directly or by implication, estoppel, or otherwise, any license under the copyrights, patents, or patent applications of Motorola or any third-party software provider, except for the normal, non-exclusive, royalty-free license to use that arises by operation of law in the sale of a product.

## Safety & General Information

**IMPORTANT INFORMATION ON SAFE AND EFFICIENT OPERATION. READ THIS INFORMATION BEFORE USING YOUR DEVICE.**

### Approved Accessories

Use of accessories not approved by Motorola, including but not limited to batteries, antennas, and convertible covers, may cause your mobile device to exceed RF energy exposure guidelines and may void your mobile device's warranty. For a list of approved Motorola accessories, visit our Web site at: [www.motorola.com](http://www.motorola.com)

### Batteries & Chargers

Your battery, charger, or mobile device may contain symbols, defined as follows:

Symbol	Definition
	Important safety information follows.

Symbol	Definition
	Do not let your battery, charger, or mobile device get wet.

## Use & Safety for Battery-Powered Accessories

- Do not store or use your battery-powered accessory (such as a Bluetooth® headset or other device) in temperatures below -10°C (14°F) or above 60°C (140°F).
- Do not recharge your accessory in temperatures below 0°C (32°F) or above 45°C (113°F).
- Conditions inside a parked car can exceed this range. Do not store your accessory in a parked car.
- Do not store your accessory in direct sunlight.
- Storing your fully charged accessory in high-temperature conditions may permanently reduce the life of the internal battery.
- Battery life may temporarily shorten in low-temperature conditions.

## Caution About High Volume Usage

**Warning:** Exposure to loud noise from any source for extended periods of time may temporarily or permanently affect your hearing. The louder the volume sound level, the less time is required before your hearing could be affected. Hearing damage from loud noise is sometimes undetectable at first and can have a cumulative effect. To protect your hearing:

- Start your volume control at a low setting and use as low a volume as possible.
- Limit the amount of time you use headsets or headphones at high volume.
- Where possible, use your headset in a quiet environment with low background noise.
- Avoid turning up the volume to block out noisy surroundings.

- Turn the volume down if you can't hear people speaking near you.

If you experience hearing discomfort, including the sensation of pressure or fullness in your ears, ringing in your ears, or muffled speech, you should stop listening to the device through your headset or headphones and have your hearing checked by your doctor.

## Smart Practices While Driving

Using a mobile device while driving may cause distraction. End a call if you can't concentrate on driving. Also, using a mobile device or accessory may be prohibited or restricted in certain areas. Always obey the laws and regulations on the use of these products.

Responsible driving practices can be found at [www.motorola.com/callsmart](http://www.motorola.com/callsmart) (in English only).

## Industry Canada Notice to Users

Operation is subject to the following two conditions: (1) This device may not cause interference and (2) This device must accept any interference, including interference that may cause undesired operation of the device. See RSS-GEN 7.1.5.

## FCC Notice to Users

**The following statement applies to all products that have received FCC approval. Applicable products bear the FCC logo, and/or an FCC ID in the format FCC-ID:xxxxxx on the product label.**

Motorola has not approved any changes or modifications to this device by the user. Any changes or modifications could void the user's authority to operate the equipment. See 47 CFR Sec. 15.21.

This device complies with part 15 of the FCC Rules. Operation is subject to the following two conditions: (1) This device may not cause harmful interference, and (2) this device must accept any interference received, including interference that may cause undesired operation. See 47 CFR Sec. 15.19(3).

This equipment has been tested and found to comply with the limits for a Class B digital device, pursuant to part 15 of the FCC Rules. These limits are designed to provide reasonable protection against harmful interference in a residential installation. This equipment generates, uses and can radiate radio frequency energy and, if not installed and used in accordance with the instructions, may cause harmful interference to radio communications. However, there is no guarantee that interference will not occur in a particular installation. If this equipment does cause harmful interference to radio or television reception, which can be determined by turning the equipment off and on, the user is encouraged to try to correct the interference by one or more of the following measures:

- Reorient or relocate the receiving antenna.
- Increase the separation between the equipment and the receiver.
- Connect the equipment to an outlet on a circuit different from that to which the receiver is connected.
- Consult the dealer or an experienced radio/TV technician for help.

## Motorola Limited Warranty for the United States and Canada

### What Does this Warranty Cover?

Subject to the exclusions contained below, Motorola, Inc. warrants its telephones, pagers, messaging devices, and consumer and professional two-way radios (excluding commercial, government or industrial radios) that operate via Family Radio Service or General Mobile Radio Service, Motorola-branded or certified accessories sold for use with these Products ("Accessories") and Motorola software contained on CD-ROMs or other tangible media and sold for use with these Products ("Software") to be free from defects in materials and workmanship under normal consumer usage for the period(s) outlined below. This limited warranty is a consumer's exclusive remedy, and applies as follows to new Motorola Products, Accessories, and Software purchased by consumers in the United States or Canada, which are accompanied by this written warranty:

## Products and Accessories

Products Covered	Length of Coverage
<b>Products and Accessories</b> as defined above, unless otherwise provided for below.	<b>One (1) year</b> from the date of purchase by the first consumer purchaser of the product unless otherwise provided for below.
<b>Decorative Accessories and Cases.</b> Decorative covers, bezels, PhoneWrap™ covers and cases.	<b>Limited lifetime warranty</b> for the lifetime of ownership by the first consumer purchaser of the product.
<b>Monaural Headsets.</b> Ear buds and boom headsets that transmit mono sound through a wired connection.	<b>Limited lifetime warranty</b> for the lifetime of ownership by the first consumer purchaser of the product.
<b>Consumer and Professional Two-Way Radio Accessories.</b>	<b>Ninety (90) days</b> from the date of purchase by the first consumer purchaser of the product.
<b>Products and Accessories that are Repaired or Replaced.</b>	<b>The balance of the original warranty or for ninety (90) days</b> from the date returned to the consumer, whichever is longer.

### Exclusions (Products and Accessories)

**Normal Wear and Tear.** Periodic maintenance, repair and replacement of parts due to normal wear and tear are excluded from coverage.

**Batteries.** Only batteries whose fully charged capacity falls below 80% of their rated capacity and batteries that leak are covered by this limited warranty.

**Abuse & Misuse.** Defects or damage that result from: (a) improper operation, storage, misuse or abuse, accident or neglect, such as physical damage (cracks, scratches, etc.) to the surface of the product resulting from misuse; (b) contact with liquid, water, rain, extreme humidity or heavy perspiration, sand, dirt or the like, extreme heat, or food; (c) use of the Products or Accessories for commercial purposes or subjecting the Product or Accessory to abnormal usage or conditions; or (d) other acts which are not the fault of Motorola, are excluded from coverage.

**Use of Non-Motorola Products and Accessories.** Defects or damage that result from the use of non-Motorola branded or certified Products, Accessories, Software or other peripheral equipment are excluded from coverage.

**Unauthorized Service or Modification.** Defects or damages resulting from service, testing, adjustment, installation, maintenance, alteration, or modification in any way by someone other than Motorola, or its authorized service centers, are excluded from coverage.

**Altered Products.** Products or Accessories with (a) serial numbers or date tags that have been removed, altered or obliterated; (b) broken seals or that show evidence of tampering; (c) mismatched board serial numbers; or (d) nonconforming or non-Motorola housings, or parts, are excluded from coverage.

**Communication Services.** Defects, damages, or the failure of Products, Accessories or Software due to any communication service or signal you may subscribe to or use with the Products Accessories or Software is excluded from coverage.

### Software

Products Covered	Length of Coverage
<b>Software.</b> Applies only to physical defects in the media that embodies the copy of the software (e.g. CD-ROM, or floppy disk).	<b>Ninety (90) days</b> from the date of purchase.

## Exclusions (Software)

**Software Embodied in Physical Media.** No warranty is made that the software will meet your requirements or will work in combination with any hardware or software applications provided by third parties, that the operation of the software products will be uninterrupted or error free, or that all defects in the software products will be corrected.

**Software NOT Embodied in Physical Media.** Software that is not embodied in physical media (e.g. software that is downloaded from the Internet), is provided "as is" and without warranty.

## Who is Covered?

This warranty extends only to the first consumer purchaser, and is not transferable.

## What Will Motorola Do?

Motorola, at its option, will at no charge repair, replace or refund the purchase price of any Products, Accessories or Software that does not conform to this warranty. We may use functionally equivalent reconditioned/refurbished/pre-owned or new Products, Accessories or parts. No data, software or applications added to your Product, Accessory or Software, including but not limited to personal contacts, games and ringer tones, will be reinstalled. To avoid losing such data, software and applications please create a back up prior to requesting service.

## How to Obtain Warranty Service or Other Information

<b>USA</b>	<b>Phones:</b> 1-800-331-6456 <b>Pagers:</b> 1-800-548-9954 <b>Two-Way Radios and Messaging Devices:</b> 1-800-353-2729
<b>Canada</b>	<b>All Products:</b> 1-800-461-4575
<b>TTY</b>	1-888-390-6456

For **Accessories** and **Software**, please call the telephone number designated above for the product with which they are used.

You will receive instructions on how to ship the Products, Accessories or Software, at your expense, to a Motorola Authorized Repair Center. To obtain service, you must include: (a) a copy of your receipt, bill of sale or other comparable proof of purchase; (b) a written description of the problem; (c) the name of your service provider, if applicable; (d) the name and location of the installation facility (if applicable) and, most importantly; (e) your address and telephone number.

## What Other Limitations are There?

ANY IMPLIED WARRANTIES, INCLUDING WITHOUT LIMITATION THE IMPLIED WARRANTIES OF MERCHANTABILITY AND FITNESS FOR A PARTICULAR PURPOSE, SHALL BE LIMITED TO THE DURATION OF THIS LIMITED WARRANTY, OTHERWISE THE REPAIR, REPLACEMENT, OR REFUND AS PROVIDED UNDER THIS EXPRESS LIMITED WARRANTY IS THE EXCLUSIVE REMEDY OF THE CONSUMER, AND IS PROVIDED IN LIEU OF ALL OTHER WARRANTIES, EXPRESS OR IMPLIED. IN NO EVENT SHALL MOTOROLA BE LIABLE, WHETHER IN CONTRACT OR TORT (INCLUDING NEGLIGENCE) FOR DAMAGES IN EXCESS OF THE PURCHASE PRICE OF THE PRODUCT, ACCESSORY OR SOFTWARE, OR FOR ANY INDIRECT, INCIDENTAL, SPECIAL OR CONSEQUENTIAL DAMAGES OF ANY KIND, OR LOSS OF REVENUE OR PROFITS, LOSS OF BUSINESS, LOSS OF INFORMATION OR DATA, SOFTWARE OR APPLICATIONS OR OTHER FINANCIAL LOSS ARISING OUT OF OR IN CONNECTION WITH THE ABILITY OR INABILITY TO USE THE PRODUCTS, ACCESSORIES OR SOFTWARE TO THE FULL EXTENT THESE DAMAGES MAY BE DISCLAIMED BY LAW.

**Some states and jurisdictions do not allow the limitation or exclusion of incidental or consequential damages, or limitation on the length of an implied warranty, so the above limitations or exclusions may not apply to you. This warranty gives you specific legal rights, and you may also have other rights that vary from state to state or from one jurisdiction to another.**

# Motorola Limited 1 Year Warranty for Accessories

## Coverage

Motorola, Inc. warrants this accessory ("Accessory") against defects in materials and workmanship under normal consumer use for 1 year from the date of purchase. Motorola, at its option, will at no charge repair, replace, or refund the purchase price of this Accessory should it not conform to this warranty. This limited warranty is a consumer's exclusive remedy, extends only to the first consumer purchaser, is not transferable, and is valid only on Accessories purchased by consumers in the United States or Canada.

## Exclusions

**Normal Wear and Tear:** Periodic maintenance, repair, and replacement of parts due to normal wear and tear are excluded from coverage.

**Batteries:** Only batteries whose fully charged capacity falls below 80% of their rated capacity and batteries that leak are covered by this limited warranty.

**Miscellaneous:** This warranty does NOT cover defects or damage that result from: (a) improper operation, storage, misuse or abuse, accident or neglect, such as physical damage (cracks, scratches, etc.) to the surface of the Accessory resulting from misuse; (b) contact with liquid, water, rain, extreme humidity or heavy perspiration, sand, dirt or the like, extreme heat, or food; (c) use of the Accessory for commercial purposes, or subjecting the Accessory to abnormal usage or conditions; (d) service, installation, alteration, or modification in any way by someone other than Motorola, or its authorized service centers and, (e) other acts which are not the fault of Motorola.

## Obtaining Service

To obtain service or information, please call 800-331-6456 in the USA or 800-461-4575 in Canada. You will receive instructions on how to ship the Accessory, at your expense, to a Motorola Service Center. To obtain service, you must include a copy of your receipt

or other comparable dated proof of purchase, a written description of the problem and your address and telephone number.

## What Other Limitations Are There?

ANY IMPLIED WARRANTIES, INCLUDING WITHOUT LIMITATION THE IMPLIED WARRANTIES OF MERCHANTABILITY AND FITNESS FOR A PARTICULAR PURPOSE, SHALL BE LIMITED TO THE DURATION OF THIS LIMITED WARRANTY. OTHERWISE THE REPAIR, REPLACEMENT, OR REFUND AS PROVIDED UNDER THIS EXPRESS LIMITED WARRANTY IS THE EXCLUSIVE REMEDY OF THE CONSUMER, AND IS PROVIDED IN LIEU OF ALL OTHER WARRANTIES, EXPRESS OR IMPLIED. IN NO EVENT SHALL MOTOROLA BE LIABLE, WHETHER IN CONTRACT OR TORT (INCLUDING NEGLIGENCE) FOR DAMAGES IN EXCESS OF THE PURCHASE PRICE OF THE ACCESSORY, OR FOR ANY INDIRECT, INCIDENTAL, SPECIAL OR CONSEQUENTIAL DAMAGES OF ANY KIND, OR LOSS OF REVENUE OR PROFITS, LOSS OF BUSINESS, LOSS OF INFORMATION OR DATA, SOFTWARE OR APPLICATIONS OR OTHER FINANCIAL LOSS ARISING OUT OF OR IN CONNECTION WITH THE ABILITY OR INABILITY TO USE THE ACCESSORY OR ANY PRODUCT USED WITH THE ACCESSORY TO THE FULL EXTENT THESE DAMAGES MAY BE DISCLAIMED BY LAW.

**Some states and jurisdictions do not allow the limitation or exclusion of incidental or consequential damages, or limitation on the length of an implied warranty, so the above limitations or exclusions may not apply to you. This warranty gives you specific legal rights, and you may also have other rights that vary from state to state or from one jurisdiction to another.**

## Product Registration

Online Product Registration:

[www.motorola.com/us/productregistration](http://www.motorola.com/us/productregistration)

Product registration is an important step toward enjoying your new Motorola product. Registering permits us to contact you for product or software updates and allows you to subscribe to updates on new products or special promotions. Registration is not required for warranty coverage.

Please retain your original dated sales receipt for your records. For warranty service of your Motorola Personal Communications Product you will need to provide a copy of your dated sales receipt to confirm warranty status.

Thank you for choosing a Motorola product.

## Export Law Assurances

This product is controlled under the export regulations of the United States of America and Canada. The Governments of the United States of America and Canada may restrict the exportation or re-exportation of this product to certain destinations. For further information contact the U.S. Department of Commerce or the Canadian Department of Foreign Affairs and International Trade.

## Caring for the Environment by Recycling

This symbol on a Motorola product means the product should not be disposed of with household waste.



## Disposal of your Mobile Device & Accessories

Please do not dispose of mobile devices or electrical accessories (such as chargers, headsets, or batteries) with your household waste. Do not dispose of your battery or mobile device in a fire. These items should be disposed of in accordance with the national collection and recycling schemes operated by your local or regional authority. Alternatively, you may return unwanted mobile devices and electrical accessories to any Motorola Approved Service Center in your region. Details of Motorola approved national recycling schemes, and further information on Motorola recycling activities can be found at:



[www.motorola.com/recycling](http://www.motorola.com/recycling)

## Disposal of your Mobile Device Packaging & Product Guide

Product packaging and product guides should only be disposed of in accordance with national collection and recycling requirements. Please contact your regional authorities for more details.

# Copyright

Motorola, Inc.  
Consumer Advocacy Office  
600 N US Hwy 45  
Libertyville, IL 60048

[www.motorola.com](http://www.motorola.com)

[www.motorola.com/motonav](http://www.motorola.com/motonav)

[www.motorola.com/bluetoothsupport](http://www.motorola.com/bluetoothsupport)

**Note:** Do not ship your device to the above address. If you need to return your device for repairs, replacement, or warranty service, please contact the Motorola Customer Support Center at:

1-877-MOTOBLU (Motorola Bluetooth support)

1-800-331-6456 (United States)

1-888-390-6456 (TTY/TDD United States for hearing impaired)

1-800-461-4575 (Canada)

Certain mobile phone features are dependent on the capabilities and settings of your service provider's network. Additionally, certain features may not be activated by your service provider, and/or the provider's network settings may limit the feature's functionality. Always contact your service provider about feature availability and functionality. All features, functionality, and other product specifications, as well as the information contained in this user's guide are based upon the latest available information and are believed to be accurate at the time of printing. Motorola reserves the right to change or modify any information or specifications without notice or obligation.

MOTOROLA and the Stylized M Logo are registered in the US Patent & Trademark Office. The Bluetooth trademarks are owned by their proprietor and used by Motorola, Inc. under license. Google is a registered trademark of Google, Inc. All other product or service names are the property of their respective owners.

© 2009 Motorola, Inc. All rights reserved.

**Caution:** Changes or modifications made in the radio phone, not expressly approved by

Motorola, will void the user's authority to operate the equipment.

**Warning:** Traffic laws and current traffic conditions must always be observed and take precedence over the instructions issued by the navigation system. The user should be aware of situations where current traffic conditions and the instructions from the navigation system may be in conflict. The use of the navigation system does not relieve the user of his/her responsibilities. The user is ultimately responsible for the vehicle under his/her control and should be aware of the surroundings at all times. For traffic safety reasons, it is recommended that routes should be planned in a stationary vehicle before starting a trip.

**Privacy:** Operation of the navigation system requires that the user's position be sent to a central server for use in certain MotoExtras features of MOTONAV. The server is operated by Airbiquity, Inc., a Motorola-approved service provider ([www.airbiquity.com](http://www.airbiquity.com)). This information will only be used to provide the requested service and will not be shared with any additional third parties. Users who prefer not to permit such tracking and monitoring should avoid using the navigation system.

**Responsibility:** Certain features of MOTONAV require wireless network access on your mobile phone. The user is responsible for all access charges.

MOTOROLA IS NOT RESPONSIBLE FOR ANY DIRECT, INDIRECT, INCIDENTAL, CONSEQUENTIAL, EXEMPLARY, SPECIAL, OR PUNITIVE DAMAGES, OR OTHER DAMAGE ARISING OUT OF THE USE OF, OR INABILITY TO USE, THIS PRODUCT. THIS INCLUDES DAMAGE TO PROPERTY AND, TO THE EXTENT PERMITTED BY LAW, DAMAGES FOR PERSONAL INJURY AND DEATH.

Laws in some areas prohibit the use of a cellular phone and other devices when driving a motor vehicle. Please use the utmost care in using your devices safely under all circumstances. It is the responsibility of each user to be aware of and abide by any and all local laws and ordinances, which may restrict the use of cellular phones and other devices.

Manual Number: TBD-A

Bluetooth ID:



## **Important Note - FCC Radiation Exposure Statement:**

This equipment complies with FCC radiation exposure limits set forth for an uncontrolled environment. End users must follow the specific operating instructions for satisfying RF exposure compliance.

To maintain compliance with FCC RF exposure compliance requirements, please follow operation instruction as documented in this manual.

This transmitter must not be co-located or operating in conjunction with any other antenna or transmitter.

## **Industry Canada Statement:**

This device complies with RSS-210 of the Industry Canada Rules. Operation is subject to the following two conditions:

- (1) This device may not cause harmful interference, and
- (2) This device must accept any interference received, including interference that may cause undesired operation of the device.

## **Important Note - Radiation Exposure Statement:**

This equipment complies with IC radiation exposure limits set forth for an uncontrolled environment. End users must follow the specific operating instructions for satisfying RF exposure compliance. To maintain compliance with IC RF exposure compliance requirements, please follow operation instruction as documented in this manual.

*Don't forget to visit [www.motorola.com/motoextras](http://www.motorola.com/motoextras) to register your device,  
download the latest software and maps,  
and purchase accessories and service upgrades for your device.*

[www.motorola.com](http://www.motorola.com)

