

User Guide

SBG940 Wireless Cable Modem Gateway





WARNING: TO PREVENT FIRE OR SHOCK HAZARD, DO NOT EXPOSE THIS PRODUCT TO RAIN OR MOISTURE. THE UNIT MUST NOT BE EXPOSED TO DRIPPING OR SPLASHING. DO NOT PLACE OBJECTS FILLED WITH LIQUIDS, SUCH AS VASES, ON THE UNIT.

CAUTION: TO PREVENT ELECTRIC SHOCK, THIS EQUIPMENT MAY REQUIRE A GROUNDING CONDUCTOR IN THE LINE CORD. CONNECT THE UNIT TO A GROUNDING TYPE AC WALL OUTLET USING THE POWER CORD SUPPLIED WITH THE UNIT.

CAUTION: THIS PRODUCT WAS QUALIFIED UNDER TEST CONDITIONS THAT INCLUDED THE USE OF THE SUPPLIED CABLES BETWEEN SYSTEMS COMPONENTS. TO ENSURE REGULATORY AND SAFETY COMPLIANCE, USE ONLY THE PROVIDED POWER AND INTERFACE CABLES AND INSTALL THEM PROPERLY.

CAUTION: DIFFERENT TYPES OF CORD SETS MAY BE USED FOR CONNECTIONS TO THE MAIN SUPPLY CIRCUIT. USE ONLY A MAIN LINE CORD THAT COMPLIES WITH ALL APPLICABLE PRODUCT SAFETY REQUIREMENTS OF THE COUNTRY OF USE.

CAUTION: INSTALLATION OF THIS PRODUCT MUST BE IN ACCORDANCE WITH NATIONAL WIRING CODES AND CONFORM TO LOCAL REGULATIONS.

CAUTION: DO NOT OPEN THE UNIT. DO NOT PERFORM ANY SERVICING OTHER THAN THAT CONTAINED IN THE INSTALLATION AND TROUBLESHOOTING INSTRUCTIONS. REFER ALL SERVICING TO QUALIFIED SERVICE PERSONNEL.

CAUTION: CHANGES AND MODIFICATIONS NOT EXPRESSLY APPROVED BY MOTOROLA FOR COMPLIANCE COULD VOID USER'S AUTHORITY TO OPERATE THE EQUIPMENT.

When using this device, basic safety precautions should always be followed to reduce the risk of fire, electric shock and injury to persons, including the following:

- Read all of the instructions listed here and/or in the user manual before you operate this equipment. Give particular attention to all safety precautions. Retain the instructions for future reference.
- This device must be installed and used in strict accordance with manufacturer's instructions as described in the user documentation that comes with the product.
- Comply with all warning and caution statements in the instructions. Observe all warning and caution symbols that are affixed to this equipment.
- Comply with all instructions that accompany this equipment.
- Do not overload outlets or extension cords, as this can result in a risk of fire or electric shock. Overloaded AC outlets, extension cords, frayed power cords, damaged or cracked wire insulation, and broken plugs are dangerous. They may result in a shock or fire hazard.
- Route power supply cords so that they are not likely to be walked on or pinched by items placed upon or against them. Pay particular attention to cords where they are attached to plugs and convenience receptacles, and examine the point where they exit from the product.
- Place this equipment in a location that is close enough to an electrical outlet to accommodate the length of the power cord.
- Place unit to allow for easy access when disconnecting the power cord of the device from the AC wall outlet.
- Do not connect the plug into an extension cord, receptacle, other outlet unless the plug can be fully inserted with no part of the blades exposed.
- Place this equipment on a stable surface.



- Postpone cable modem installation until there is no risk of thunderstorm or lightning activity in the area.
- *Avoid using this product during an electrical storm.* There may be a risk of electric shock from lightning. For added protection for this product during a lightning storm, or when it is left unattended and unused for long periods of time, unplug it from the wall outlet, and disconnect the cable system. This will prevent damage to the product due to lightning and power surges.
- It is recommended that the customer install an AC surge protector in the AC outlet to which this device is connected. This is to avoid damaging the equipment by local lightning strikes and other electrical surges.
- Do not cover the device, or block the airflow to the device with any other objects. Keep the device away from excessive heat and humidity and keep the device free from vibration and dust.
- Wipe the unit with a clean, dry cloth. Never use cleaning fluid or similar chemicals. Do not spray cleaners directly on the unit or use forced air to remove dust.
- Avoid damaging the cable modem with static by touching the coaxial cable when it is attached to the earth grounded coaxial cable TV wall outlet.
- Always first touch the coaxial cable connector on the cable modem when disconnecting or re-connecting USB or Ethernet cable from the cable modem or the user's PC.
- Operate this product only from the type of power source indicated on the product's marking label. If you are not sure of the type of power supplied to your home, consult your dealer or local power company.
- Upon completion of any service or repairs to this product, ask the service technician to perform safety checks to determine that the product is in safe operating condition.

Be sure that the outside cable system is grounded, so as to provide some protection against voltage surges and built-up static charges. Article 820-20 of the NEC (Section 54, Part I of the Canadian Electrical Code) provides guidelines for proper grounding and, in particular, specifies the CATV cable ground shall be connected in the grounding system of the building, as close to the point of cable entry as practical.

Apparaten skall anslutas till jordat uttag när den ansluts ett näverk.

FCC Compliance Class B Digital Device

This device complies with part 15 of the FCC Rules. Operation is subject to the following two conditions: (1) This device may not cause harmful interference, and (2) this device must accept any interference received, including interference that may cause undesired operation.

Note: This equipment has been tested and found to comply with the limits for a Class B digital device, pursuant to part 15 of the FCC Rules. These limits are designed to provide reasonable protection against harmful interference in a residential installation. This equipment generates, uses and can radiate radio frequency energy and, if not installed and used in accordance with the instructions, may cause harmful interference to radio communications. However, there is no guarantee that interference will not occur in a particular installation. If this equipment does cause harmful interference to radio or television reception, which can be determined by turning the equipment off and on, the user is encouraged to try to correct the interference by one or more of the following measures:

- Reorient or relocate the receiving antenna.
- Increase the separation between the equipment and receiver.
- Connect the equipment into an outlet on a circuit different from that to which the receiver is connected.
- Consult the dealer or an experienced radio/TV technician for help.



FCC Certification

This product contains a radio transmitter and accordingly has been certified as compliant with 47 CFR Part 15 of the FCC Rules for intentional radiators. Products that contain a radio transmitter are labeled with FCC ID and the FCC logo.

CAUTION: Exposure to Radio Frequency Radiation.

To comply with the FCC RF exposure compliance requirements, the separation distance between the antenna and any person's body (including hands, wrists, feet and ankles) must be at least 20 cm (8 inches).

Canada - Industry Canada (IC)

The wireless radio of this device complies with RSS 210 and RSS 102 of Industry Canada.

This Class B digital device complies with Canadian ICES-003.

Cet appareil numérique de la classe B est conforme à la norme NMB-003 du Canada.

To prevent radio interference to the licensed service, this device is intended to be operated indoors and away from windows to provide maximum shielding. Equipment (or its transmit antenna) that is installed outdoors is subject to licensing.

Only use the antenna(s) provided with this product or an antenna approved by Motorola.

Regulatory, Safety, Software License, and Warranty Information Card

This product is provided with a separate *Regulatory, Safety, Software License, and Warranty Information* card. If one is not provided with this product, please ask your service provider or point-of-purchase representative, as the case may be.

- THIS PRODUCT IS IN COMPLIANCE WITH ONE OR MORE OF THE STANDARDS LISTED ON THE *REGULATORY, SAFETY, SOFTWARE LICENSE, AND WARRANTY INFORMATION CARD*. NOT ALL STANDARDS APPLY TO ALL MODELS.
- NO WARRANTIES OF ANY KIND ARE PROVIDED BY MOTOROLA WITH RESPECT TO THIS PRODUCT, EXCEPT AS STATED ON THE *REGULATORY, SAFETY, SOFTWARE LICENSE, AND WARRANTY INFORMATION CARD*. MOTOROLA'S WARRANTIES DO NOT APPLY TO PRODUCT THAT HAS BEEN REFURBISHED OR REISSUED BY YOUR SERVICE PROVIDER.

Copyright © 2004 by Motorola, Inc.

All rights reserved. No part of this publication may be reproduced in any form or by any means or used to make any derivative work (such as translation, transformation or adaptation) without written permission from Motorola, Inc.

Motorola reserves the right to revise this publication and to make changes in content from time to time without obligation on the part of Motorola to provide notification of such revision or change. Motorola provides this guide without warranty of any kind, either implied or expressed, including, but not limited to, the implied warranties of merchantability and fitness for a particular purpose. Motorola may make improvements or changes in the product(s) described in this manual at any time.

MOTOROLA and the Stylized M Logo are registered in the US Patent & Trademark Office. Microsoft, Windows, Windows Me, Windows NT, and Xbox are registered trademarks and Windows XP and Xbox Live are trademarks of Microsoft Corporation. Microsoft Windows screen shots are used by permission of Microsoft Corporation. Macintosh and AppleTalk are registered trademarks of Apple Computer, Inc. Iomega is a registered trademark of Iomega Corporation. Linux is a registered trademark of Linus Torvalds. Acrobat Reader is a registered trademark of Adobe Systems, Inc. Netscape and Navigator are registered trademarks of Netscape Communications Corporation. PlayStation is a registered trademark of Sony Computer Entertainment Inc. UNIX is a registered trademark of the Open Group in the United States and other countries. Wi-Fi is a registered trademark of the Wi-Fi Alliance. All other product or service names are the property of their respective owners.

Contents

Overview	1	Setting the Firewall Policy	30
Easy Setup	2	Firewall > POLICY — advanced Page	32
Network Connection Types	2	Firewall > ALERT — basic Page	34
Powerful Features in a Single Unit	2	Firewall > ALERT — email Page	35
Sample Hybrid LAN	3	Firewall > LOGS Page	36
Optional Accessories	4	Gaming Configuration Guidelines	37
Front Panel	5	Configuring the Firewall for Gaming	37
Rear Panel	6	Configuring Port Triggers	37
Label on the Bottom of the SBG940	7	Configuring a Gaming DMZ Host	38
SBG940 LAN Choices	7	Configuring the Gateway	39
Wireless LAN	8	Gateway > STATUS Page	40
Wired Ethernet LAN	9	Gateway > WAN Page	41
USB Connection	11	Gateway > LAN — nat config Page	43
Security	12	Gateway > LAN — dhcp server config Page	44
Firewall	12	Gateway > LAN — dhcp leases Page	45
DMZ	13	Gateway > PORT FORWARDING — status Page ...	46
Port Triggering	13	Gateway > PORT FORWARDING — config Page ...	47
Wireless Security	13	Gateway > PORT TRIGGERS — predefined Page ..	48
Port Forwarding	14	Gateway > PORT TRIGGERS — custom Page	50
Virtual Private Networks	14	Gateway > LOG Page	51
Related Documentation	14	Configuring TCP/IP	52
Installation	15	Configuring TCP/IP in Windows 95, Windows 98, or	
Before You Begin	15	Windows Me	52
Precautions	16	Configuring TCP/IP in Windows 2000	55
Signing Up for Service	16	Configuring TCP/IP in Windows XP	59
Computer System Requirements	17	Verifying the IP Address in Windows 95, Windows 98,	
Connecting the SBG940 to the Cable System	18	or Windows Me	63
Cabling the LAN	18	Verifying the IP Address in Windows 2000 or Windows XP ..	64
Obtaining an IP Address for Ethernet	19	Setting Up Your Wireless LAN	66
Obtaining an IP Address in Windows 98,		Encrypting Wireless LAN Transmissions	67
Windows 98 SE, or Windows Me	19	Configuring WPA on the SBG940	68
Obtaining an IP Address in Windows 2000 or		Configuring WEP on the SBG940	70
Windows XP	19	Restricting Wireless LAN Access	72
Obtaining an IP Address on Macintosh or UNIX		Configuring the Wireless Network Name on	
Systems	19	the SBG940	73
Connecting a PC to the USB Port	20	Configuring a MAC Access Control List on the SBG940 ..	75
Wall Mounting	21	Configuring the Wireless Clients	76
Wall Mounting Template	23	Configuring a Wireless Client for WPA	77
		Configuring a Wireless Client for WEP	77
		Configuring a Wireless Client with the Network	
		Name (ESSID)	77
Basic Configuration	24		
Starting the SBG940 Setup Program	25		
Changing the Default Password	27		
Enabling Remote Access	28		
Getting Help	29		



Wireless Pages in the SBG940 Setup Program 78
Wireless > STATUS Page 79
Wireless > NETWORK Page 80
Wireless > SECURITY — basic Page 82
Wireless > SECURITY — advanced Page 83
Wireless > STATISTICS page 84

Setting Up a USB Driver 86

Setting Up a USB Driver in Windows 98 87
Setting Up a USB Driver in Windows 2000 91
Setting Up a USB Driver in Windows Me 94
Setting Up a USB Driver in Windows XP 95
Removing the USB Driver from Windows 98 or
Windows Me 96
Removing the USB Driver from Windows 2000 99
Removing the USB Driver from Windows XP 102

Troubleshooting 107

Front-Panel Lights and Error Conditions 108

Contact Us 109

Frequently-Asked Questions 110

Specifications 112

Glossary 114

Software License 132

Overview

Thank you for purchasing a Motorola® SURFboard® Wireless Cable Modem Gateway SBG940 for your home, home office, or small business/enterprise. Applications where the SURFboard Gateway (SBG) is especially useful include:

- Households having multiple computers requiring connection to the Internet and each other
- Small businesses or home offices requiring fast, affordable, and secure Internet access
- Internet gamers desiring easier setup for:
 - Programs such as DirectX® 7 or DirectX® 8
 - Sites such as MSN Games by [Zone.com](#) or [Battle.net®](#)
- Video conferencing



The features and physical appearance of your SBG940 may differ slightly from the picture.

A home network enables you to share information between two or more computers. You can connect your home network to the Internet through the cable TV system. The SBG940 is the *central connection point* between your computers and the Internet. It directs (routes) information between the computers connected to your home network. A built-in cable modem transmits information between your home network and the Internet. An SBG940:

- Combines four separate products — a DOCSIS® cable modem, [IEEE 802.11g](#) wireless [access point](#), Ethernet 10/100Base-T connections, and [firewall](#) — into one compact unit
- Enables you to create a custom network sharing a single [broadband](#) connection, files, and peripherals, with or without wires
- Has an advanced firewall for enhanced network security for wired and wireless users
- Provides easy setup

This product is subject to change. Not all features described in this guide are available on all SBG940 models.

For the most recent documentation, visit the [Cable Modems and Gateways](#) page on the Motorola Broadband website <http://broadband.motorola.com/>.

Easy Setup

It is much easier to configure a local area network (LAN) using an SBG940 than using traditional networking equipment:

- For basic operation, most default settings require no modification.
- The Setup Program provides a graphical user interface (GUI) for easy configuration of necessary wireless, Ethernet, router, DHCP, and security settings. For information about using the Setup Program, see “[Basic Configuration](#)”.

Network Connection Types

The SBG940 provides different network connection types for your computers to exchange data. The connection between your computers and the SBG940 may be with a wireless or a wired connection or a combination of the two. Your network can use one or any combination of all the following network connections:

- Ethernet local area network (LAN)
- Wireless LAN (IEEE 802.11g that also supports IEEE 802.11b wireless clients)
- Universal Serial Bus (USB)

Powerful Features in a Single Unit

An SBG940 combines high-speed Internet access, networking, and computer security for a home or small-office LAN. An SBG940 provides:

- An integrated high-speed SURFboard cable modem for continuous broadband access to the Internet and other online services, with much faster data transfer than traditional dial-up or ISDN modems
- A single broadband connection for up to 253 computers to surf the web; all computers on the LAN communicate as if they were connected to the same physical network
- An [IEEE 802.11g](#) wireless access point to enable laptop users to remain connected while moving around the home or small office or to connect desktop computers without installing network wiring. Depending on distance, wireless connection speeds can match that of Ethernet.
- A USB connection for a single PC
- Four 10/100Base-T Ethernet uplink ports supporting half- or [full-duplex](#) connections and [Auto-MDIX](#)
- [Routing](#) for a wireless LAN (WLAN) or a wired Ethernet LAN; you can connect more than four computers using hubs and/or switches
- A built-in DHCP server to easily configure a combined wired and/or wireless Class C private LAN
- An advanced [firewall](#) supporting [stateful-inspection](#), intrusion detection, [DMZ](#), denial-of-service attack prevention, and Network Address Translation (NAT)
- Virtual private network (VPN) [pass-through](#) operation supporting IPSec, PPTP, or L2TP to securely connect remote computers over the Internet
- [Port Forwarding](#) to configure ports to run applications having special network requirements

Sample Hybrid LAN

The sample LAN illustrated on this page contains the following devices, all protected by the SBG940 firewall. Clockwise from top-right, the devices are:

- A PDA on a wireless connection
- One desktop Apple Macintosh® computer on a wireless connection
- One desktop PC on a wireless connection using a Motorola [Wireless PCI Adapter](#)
- A laptop PC on a wireless connection using a Motorola [Wireless Notebook Adapter](#)
- One PC connected to the USB port
- Three computers connected to Ethernet port one using a hub or switch
- One computer connected directly to Ethernet port two

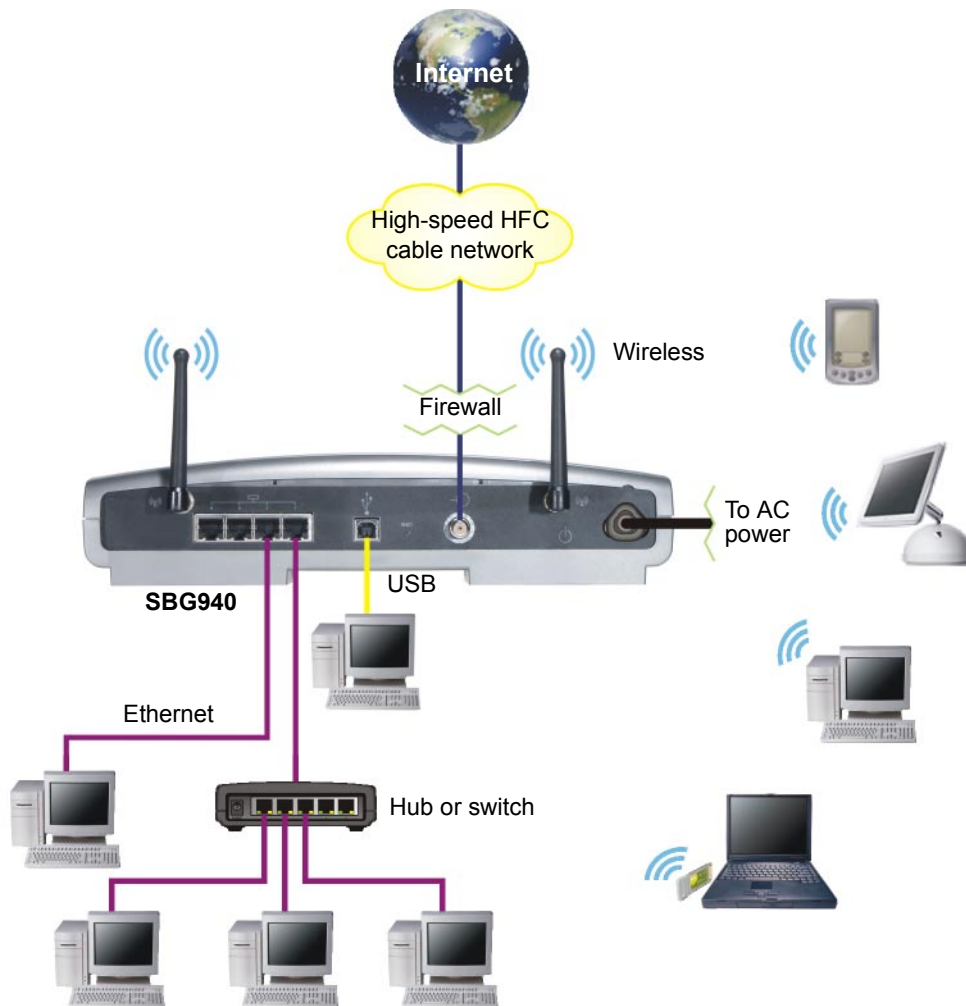

Optional Accessories

All networks are composed of multiple devices. The SBG940 works with any IEEE 802.11g or IEEE 802.11b compliant client product. Motorola supplies a range of accessories for use with the SBG940. Some examples are:



Wireless Ethernet
Bridge WE800G



Ethernet Broadband
Router BR700



Wireless Notebook
Adapter WN825G



Wireless USB
Adapter WU830G



Wireless PCI Adapter
WPCI810G

For up-to-date information about accessories and home networking options, including product documentation, visit the Motorola Home Networking page http://broadband.motorola.com/consumers/home_networking.asp.

Front Panel

The front panel provides indicator lights. The display is dark unless there is a connection or activity on an interface:

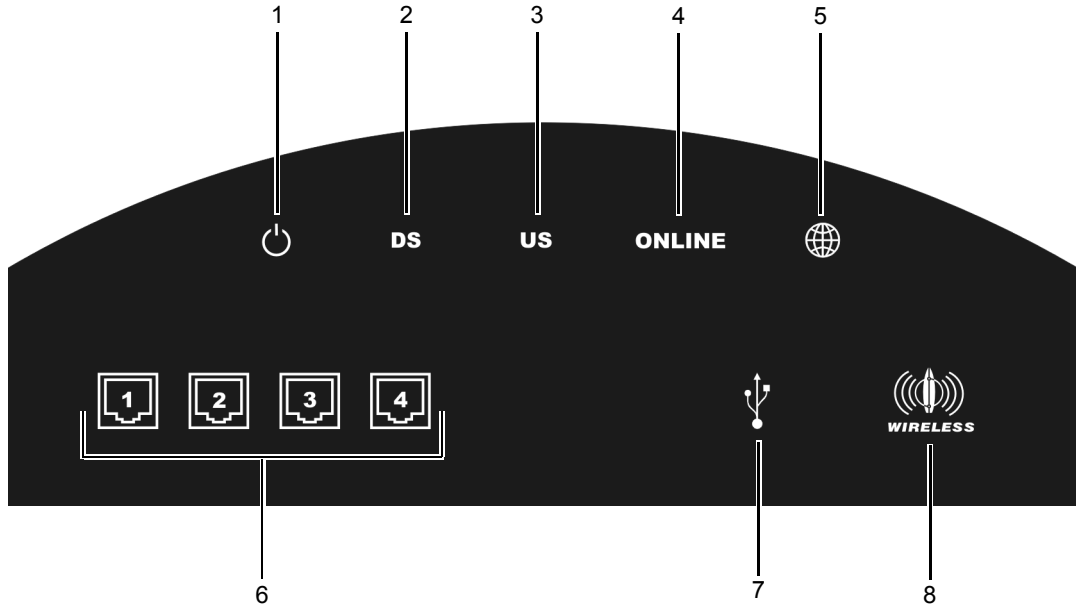



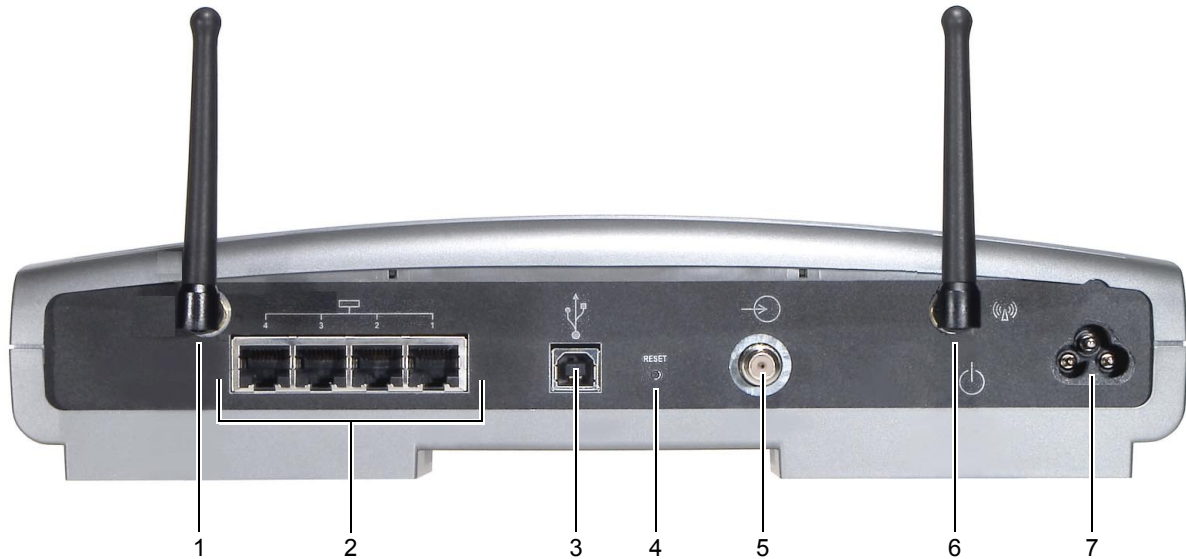

Key	Light	Flashing	On
1		Never flashes	The AC power is connected properly
2	DS	Scanning for a receive (downstream) channel connection	The downstream channel is connected
3	US	Scanning for a send (upstream) channel connection	The upstream channel is connected
4	ONLINE	Scanning for a network connection	The startup process is complete and the SBG940 is online
5		Transmitting or receiving data over the Internet	Is never lit solid
6		Ethernet activity on the port (1 to 4)	There is a connection to the port (1 to 4): <ul style="list-style-type: none"> • Green for 100Base-T • Yellow for 10Base-T
7		USB activity	Lights green if there is a proper USB connection
8		Wireless activity	The wireless interface is on (Enable Wireless Interface is selected on the Wireless > NETWORK Page in the SBG940 Setup Program)

Rear Panel

The rear panel provides cabling connectors, status lights, and the power receptacle:



Key	Item	Description
-----	------	-------------

- | | | |
|---|---|---|
| 1 | | An adjustable, but non-removable antenna. <i>Do not attempt to force this antenna off the unit.</i> |
| 2 |  | Use any Ethernet port to connect an Ethernet LAN cable with RJ-45 connectors to an Ethernet-equipped computer, hub, bridge, switch or Xbox or PlayStation [®] 2 gaming console. |
| 3 |  | For Windows <i>only</i> , use the USB port for Connecting a PC to the USB Port . You cannot connect the SBG940 USB port to a Macintosh or UNIX [®] computer. |
| 4 | RESET | If you experience a problem, you can push this recessed button to restart the SBG940 (see "Troubleshooting"). To reset all values to their defaults, hold down the button for more than five seconds. Resetting may take 5 to 30 minutes because the SBG940 must find and lock on the appropriate communications channels. |
| 5 |  | Use the cable connector to connect to the coaxial cable outlet. |
| 6 |  | Removable, adjustable antenna. If necessary, contact your cable provider about obtaining an optional Motorola wireless high gain antenna to increase WLAN performance and coverage. |
| 7 |  | Use the AC connector to connect to the AC power outlet. |

Label on the Bottom of the SBG940

To receive data service, you need to provide the [MAC address](#) marked **HFC MAC ID** to your cable provider:



SBG940 LAN Choices

The SBG940 enables you to connect up to 253 [client](#) computers on a combination of:

- [Wireless LAN](#)
- [Wired Ethernet LAN](#)
- [USB Connection](#)

Each computer needs appropriate network [adapter](#) hardware and [driver](#) software. The clients on the Ethernet, wireless, or USB interfaces can share:

- Internet access with a single cable provider account, subject to cable provider terms and conditions
- Files, printers, storage devices, multi-user software applications, games, and video conferencing

Wireless and wired network connections use Windows networking to share files and peripheral devices such as printers, CD-ROM drives, floppy disk drives, and Iomega® Zip Drives.

Wireless LAN

Wireless communication occurs over radio waves rather than a wire. Like a cordless telephone, a WLAN uses radio signals instead of wires to exchange data. A wireless network eliminates the need for expensive and intrusive wiring to connect computers throughout the home or office. Mobile users can remain connected to the network even when carrying their laptop to different locations in the home or office.

Each computer on a WLAN requires a wireless adapter shown in “[Optional Accessories](#)”:

Laptop PCs Use a Motorola [Wireless Notebook Adapter](#) or compatible product in the PCMCIA slot.

Desktop PCs Use a Motorola [Wireless PCI Adapter](#), Wireless USB Adapter, or compatible product in the PCI slot or USB port, respectively.

Sample wireless network connections



To set up the SBG940, on a computer wired to the SBG940 over Ethernet or USB, perform the procedures in “[Setting Up Your Wireless LAN](#)”. *Do not attempt to configure the SBG940 over a wireless connection.*

Your maximum wireless operation distance depends on the type of materials through which the signal must pass and the location of your antennas and [clients](#) (stations). *Motorola cannot guarantee wireless operation for all supported distances in all environments.*

An optional Motorola high [gain](#) antenna can improve wireless performance. For information about available optional antennas for your SBG940, contact your cable provider.

Wired Ethernet LAN

Each computer on the 10/100Base-T Ethernet LAN requires an Ethernet network interface card (NIC) and driver software installed. Because the SBG940 Ethernet port supports [auto-MDIX](#), you can use straight-through or cross-over cable to connect a hub, switch, or computer. Use category 5 cabling for all Ethernet connections.

The physical wiring arrangement has no connection to the logical network allocation of IP addresses.

Sample Ethernet to computer connection

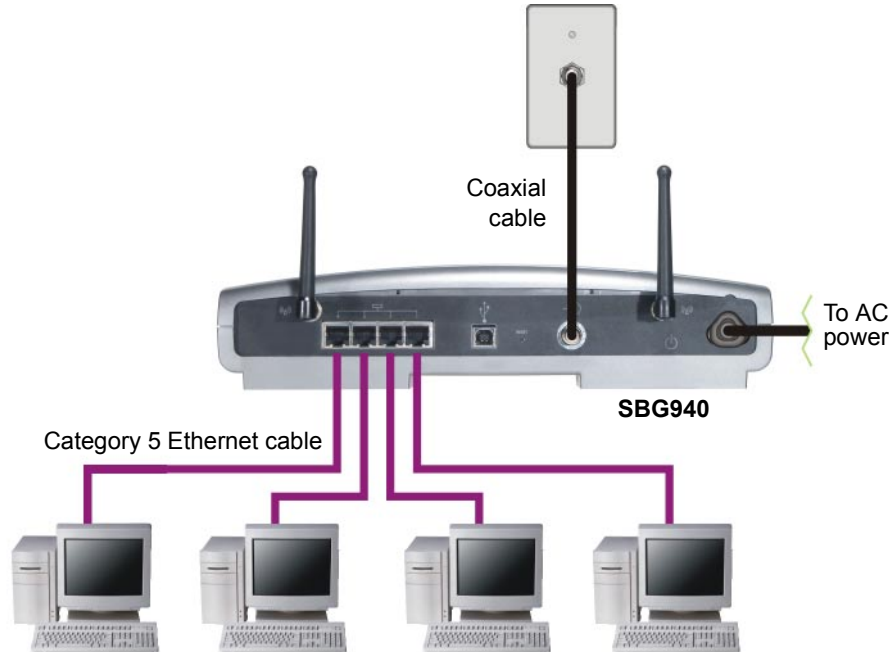

A wired Ethernet LAN with more than four computers requires one or more [hubs](#), [switches](#), or [routers](#). You can:

- Connect a hub or switch to any Ethernet port on the SBG940
- Use Ethernet hubs, switches, or routers to connect up to 253 computers to the SBG940

The following illustration is an example of an Ethernet LAN you can set up using the SBG940. Cable the LAN in an appropriate manner for the site. A complete discussion of Ethernet cabling is beyond the scope of this document.

Sample Ethernet connection to hubs or switches

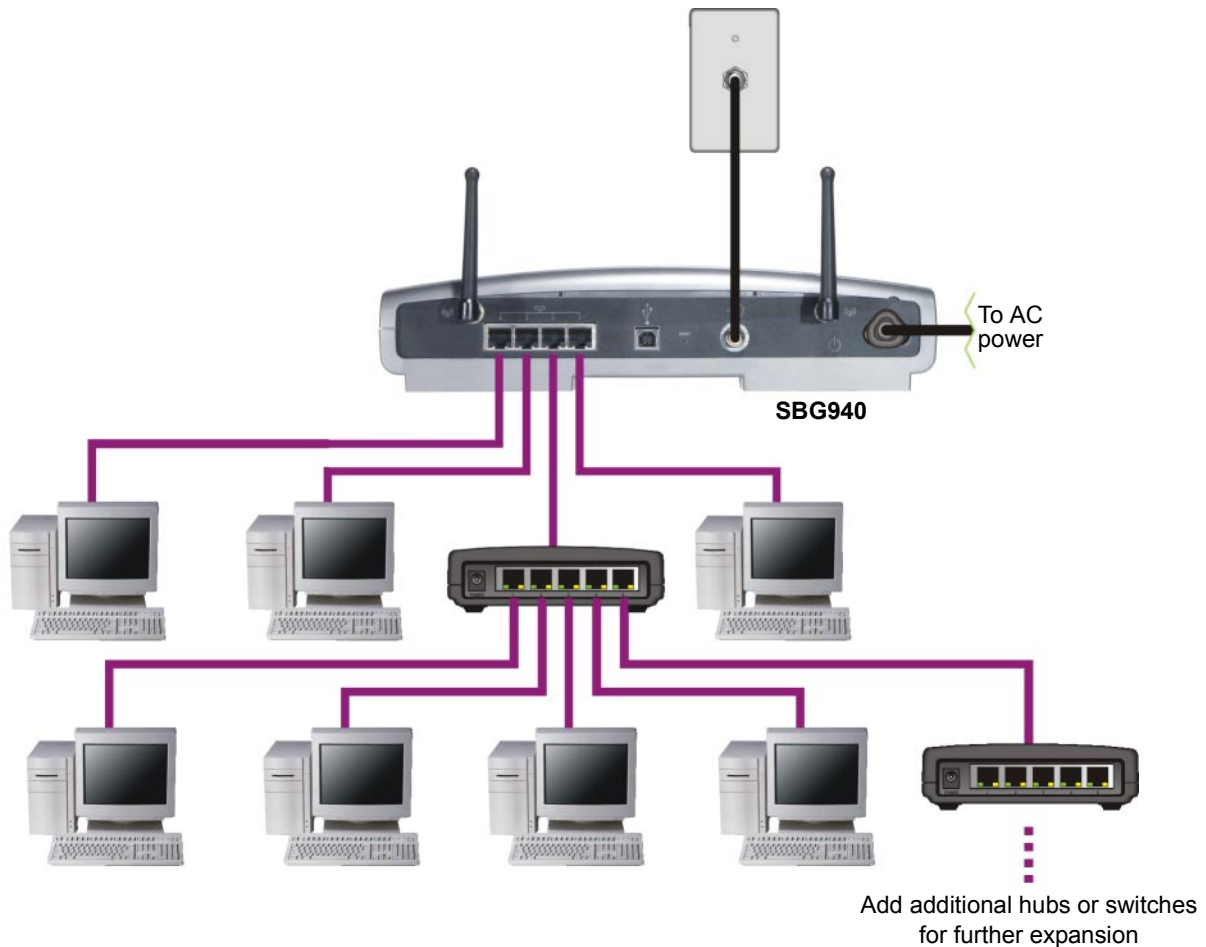

USB Connection

You can connect a single PC running Windows® 98, Windows XP™, Windows Me®, or Windows® 2000 to the SBG940 USB V1.1 port. For cabling instructions, see “[Connecting a PC to the USB Port](#)”.

Caution!



Before plugging in the USB cable, be sure the SBG940 Installation CD-ROM is inserted in the PC CD-ROM drive.

Sample USB connection

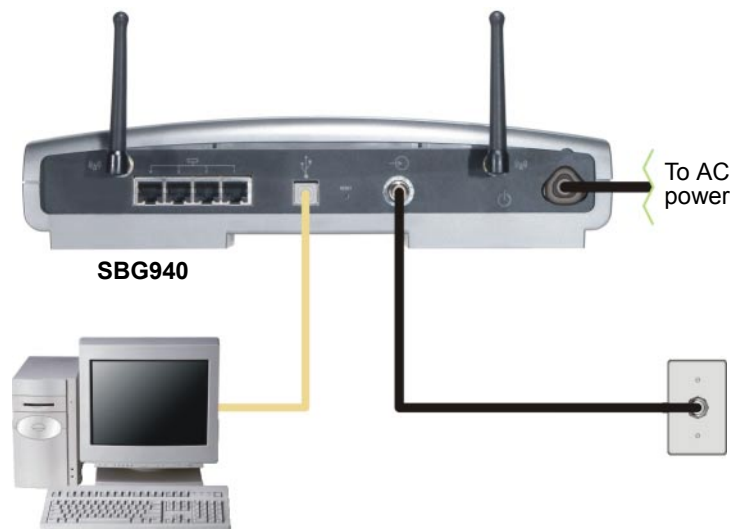

Security

The SBG940 provides:

- A **firewall** to protect the SBG940 LAN from undesired attacks over the Internet
- For wireless transmissions, data encryption and network access control

Network Address Translation (**NAT**) provides some security because the IP addresses of SBG940 LAN computers are not visible on the Internet.

This diagram does not necessarily correspond to the network cabling. A full discussion of network security is beyond the scope of this document.

SBG940 security measures shown in a logical network diagram

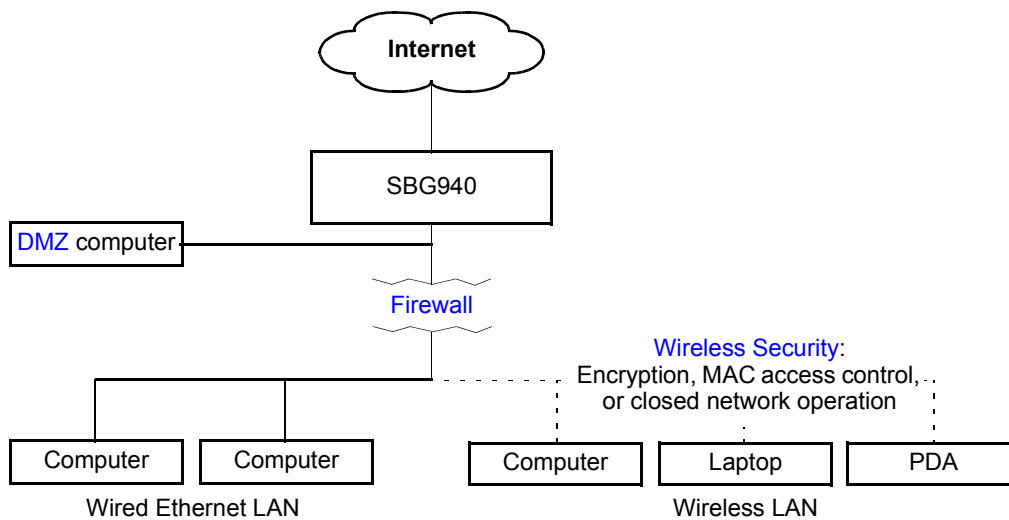

Firewall

The SBG940 firewall protects the SBG940 LAN from undesired attacks and other intrusions from the Internet. It provides an advanced integrated **stateful-inspection** firewall supporting intrusion detection, session tracking, and denial-of-service attack prevention. The firewall:

- Maintains state data for every **TCP/IP** session on the **OSI** network and transport layers
- Monitors all incoming and outgoing **packets**, applies the firewall policy to each one, and screens for improper packets and intrusion attempts
- Provides comprehensive logging for all:
 - User authentications
 - Rejected internal and external connection requests
 - Session creation and termination
 - Outside attacks (intrusion detection)

You can configure the firewall filters to set rules for port usage. For information about choosing a predefined firewall policy template, see [“Setting the Firewall Policy”](#).



DMZ

A de-militarized zone (DMZ) is one or more computers logically located outside the firewall between an SBG940 LAN and the Internet. A DMZ prevents direct access by outside users to private data.

For example, you can set up a web server on a DMZ computer to enable outside users to access your website without exposing confidential data on your network.

A DMZ can also be useful to play interactive games that may have a problem running through a firewall. You can leave a computer used for gaming *only* exposed to the Internet while protecting the rest of your network. For more information, see “[Gaming Configuration Guidelines](#)”.

Port Triggering

When you run an application that accesses the Internet, it typically initiates communications with a computer on the Internet. For some applications, especially gaming, the computer on the Internet also initiates communications with your computer. Because NAT does not normally allow these incoming connections:

- The SBG940 has preconfigured port triggers for common applications.
- If needed, you can configure additional port triggers on the [Gateway > PORT TRIGGERS — custom Page](#).

Wireless Security

Because WLAN data is transmitted using radio signals, it may be possible an unauthorized person to access your WLAN unless you prevent them from doing so. *To prevent unauthorized eavesdropping of data transmitted over your LAN, you must enable wireless security. The default SBG940 settings neither provide security for transmitted data nor protect network data from unauthorized intrusions.*

The SBG940 provides the following wireless security measures, which are described in “[Setting Up Your Wireless LAN](#)”:

- To prevent unauthorized eavesdropping, you must encrypt data transmitted over the wireless interface using one of:
 - If all of your wireless clients support Wi-Fi® Protected Access (WPA) encryption, we recommend using WPA (see “[Configuring WPA on the SBG940](#)” and “[Configuring a Wireless Client for WPA](#)”).
 - Otherwise, configure a Wired Equivalency Privacy (WEP) key on the SBG940 and each WLAN client (see “[Configuring WEP on the SBG940](#)” and “[Configuring a Wireless Client for WEP](#)”).
- To protect LAN data from unauthorized intrusions, you can restrict WLAN access to computers having one or both of:
 - Known MAC addresses (see “[Configuring a MAC Access Control List on the SBG940](#)”)
 - The same unique network name (ESSID) as the SBG940 (see “[Configuring the Wireless Network Name on the SBG940](#)” and “[Configuring a Wireless Client with the Network Name \(ESSID\)](#)”)

Restricting access to computers having the same network name is also called “disabling ESSID broadcasting” or “enabling closed network operation.”

Port Forwarding

The SBG940 opens logical data ports when a computer on its LAN sends data, such as e-mail messages or web data, to the Internet. A logical data port is different from a physical port, such as an Ethernet port. Data from a protocol must go through certain data ports.

Some applications, such as games and videoconferencing, require multiple data ports. If you enable NAT, this can cause problems because NAT assumes that data sent through one port will return to the same port. You may need to configure port forwarding to run applications with special requirements.

To configure port forwarding, you must specify an inbound (source) port or range of ports. The inbound port opens only when data is sent to the inbound port and closes again after a specified time elapses with no data sent to it. You can configure up to 32 port forwarding entries using the [Gateway > PORT FORWARDING — config Page](#).

Virtual Private Networks

The SBG940 supports multiple [tunnel](#) VPN [pass-through](#) operation to securely connect remote computers over the Internet. The SBG940:

- Is compatible with Point to Point Tunneling Protocol ([PPTP](#)) and Layer 2 Tunneling Protocol ([L2TP](#))
- Is fully interoperable with any [IPSec](#) client or gateway and [ANX](#) certified IPSec stacks

Related Documentation

The *SBG940 Quick Installation Guide* also provides information about using the SBG940.

For information about and documentation for Motorola home-networking products, visit the Motorola Home Networking page http://broadband.motorola.com/consumers/home_networking.asp.

❖ Installation





The following subsections provide information about installing the SBG940 hardware:

- [Before You Begin](#)
- [Precautions](#)
- [Signing Up for Service](#)
- [Computer System Requirements](#)
- [Connecting the SBG940 to the Cable System](#)
- [Cabling the LAN](#)
- [Obtaining an IP Address for Ethernet](#)
- [Connecting a PC to the USB Port](#)
- [Wall Mounting](#)

For information about WLAN setup, see “[Setting Up Your Wireless LAN](#)”.

Before You Begin

Before you begin the installation, check that you received the following items with your SBG940:

Item		Description
Power cord		Connects the SBG940 to the AC electrical outlet
10/100Base-T Ethernet cable		Connects to the Ethernet port
USB cable		Connects to the USB port
SBG940 Installation CD-ROM		Contains this <i>User Guide</i> and USB drivers

You will need 75-ohm [coaxial cable](#) with F-type connectors to connect the SBG940 to the nearest cable outlet. If a TV is connected to the cable outlet, you may need a 5 to 900 MHz RF [splitter](#) and two additional coaxial cables to use both the TV and the SBG940.

Determine the connection types you will make to the SBG940. Check that you have the required cables, adapters, and adapter software. You may need:

Wireless LAN	Wireless adapter and driver software for each computer having a wireless connection (see “ Optional Accessories ”)
Wired Ethernet LAN	Ethernet cables and network interface cards (NICs) with accompanying installation software To connect more than four computers to the SBG940, one or more Ethernet hubs or switches
USB	A USB cable and the <i>SBG940 Installation</i> CD-ROM containing the software for USB installation

Coaxial cable, RF splitters, hubs, and switches are available at consumer electronic stores.

Precautions

Postpone SBG940 installation until there is no risk of thunderstorm or lightning activity in the area.

To avoid damaging the SBG940 or computers with static electricity:

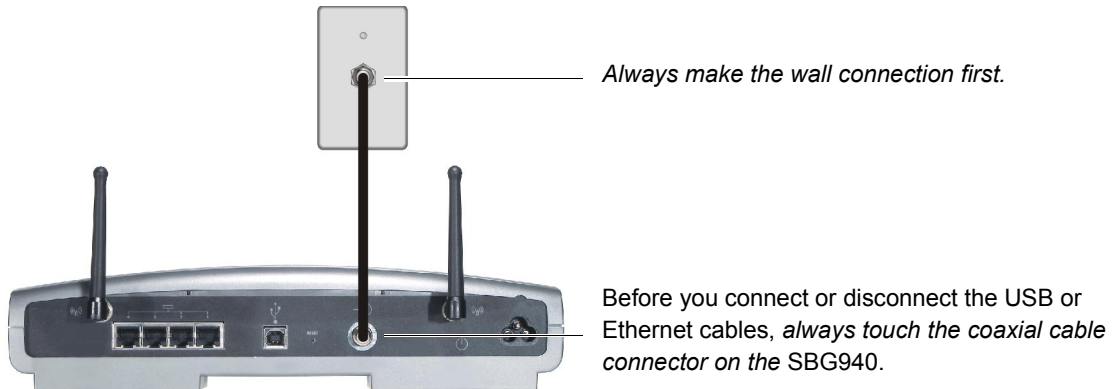

To avoid potential shock, always unplug the power cord from the wall outlet or other power source before disconnecting it from the SBG940 rear panel.

To prevent overheating the SBG940, do not block the ventilation holes on the sides of the unit.

Do not open the unit. Refer all service to your cable provider.

Wipe the unit with a clean, dry cloth. Never use cleaning fluid or similar chemicals. Do not spray cleaners directly on the unit or use forced air to remove dust.

Signing Up for Service

You must sign up with a cable provider to access the Internet and other online services.

To activate your service, call your local cable provider.

You need to provide the MAC address marked **HFC MAC ID** printed on the [Label on the Bottom of the SBG940](#). You can record it in the SBG940 *Quick Installation Guide*.

You should ask your cable provider the following questions:

- Do you have any special system requirements?
- When can I begin to use my SBG940?
- Are there any files I need to download after I am connected?
- Do I need a user name or password to access the Internet or use e-mail?

Computer System Requirements

You can connect Microsoft Windows, Macintosh, UNIX[®], or Linux[®] computers equipped as follows to the SBG940 LAN:

- One of the following:

Ethernet 10Base-T or 10/100Base-T Ethernet adapter with proper NIC driver software installed.

Wireless Any IEEE 802.11g or IEEE 802.11b device. For information about the Motorola WN825G Wireless Card (PCMCIA type II 3.3 V slot) or WPC1810G Wireless Adapter, see "[Optional Accessories](#)".

- PC with Pentium class or better processor
- Windows[®] 98, Windows[®] 98 SE, Windows Me[®], Windows[®] 2000, Windows XP[™], Windows NT[®], Macintosh, or Linux operating system with operating system CD-ROM available
- Minimum 16 MB RAM recommended
- 10 MB available hard disk space



You can use any web browser such as Microsoft[®] Internet Explorer or Netscape Navigator[®] with the SBG940.

You can use the USB connection with any PC running Windows 98, Windows 2000, Windows Me, or Windows XP that has a USB interface. The USB connection requires special USB driver software that is supplied on the *SBG940 Installation* CD-ROM. You can upgrade your USB drivers from the Motorola [Downloads](#) page http://broadband.motorola.com/noflash/usb_drivers.asp.

Connecting the SBG940 to the Cable System

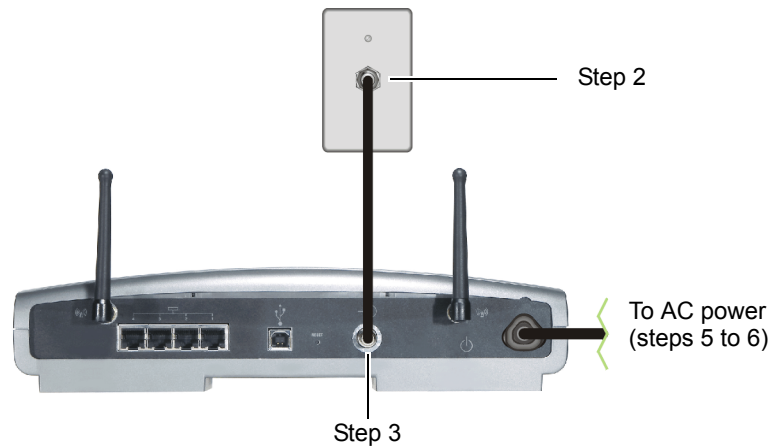
- 1 Be sure the computer is on and the SBG940 is unplugged.
- 2 Connect one end of the coaxial cable to the cable outlet or splitter.
- 3 Connect the other end of the coaxial cable to the cable connector on the SBG940.
Hand-tighten the connectors to avoid damaging them.
- 4 Insert the *SBG940 Installation* CD-ROM into the CD-ROM drive.
- 5 Plug the power cord into the power connector on the SBG940.
- 6 Plug the power cord into the electrical outlet. *This turns the SBG940 on. You do not need to unplug it when not in use. The first time you plug in the SBG940, allow 5 to 30 minutes to find and lock on the appropriate communications channels.*



- 7 Check that the lights on the front panel cycle through this sequence:
 -  Turns on when AC power is connected to the SBG940. Indicates that the power is connected properly.
 - DS** Flashes while scanning for the downstream receive channel. Changes to solid green when the receive channel is locked.
 - US** Flashes while scanning for the upstream send channel. Changes to solid green when the send channel is locked.
 - ONLINE** Flashes during SBG940 registration and configuration. Changes to solid green when the SBG940 is registered.
 -  Flashes when the SBG940 is transmitting or receiving data over the Internet.

Cabling the LAN

After connecting to the cable system, you can connect your wired Ethernet LAN. Some samples are shown in “[Wired Ethernet LAN](#)”. On each networked computer, you must install proper drivers for the Ethernet NIC. Detailed information about network cabling is beyond the scope of this document.

Obtaining an IP Address for Ethernet

Obtaining an IP Address in Windows 98, Windows 98 SE, or Windows Me

You must do the following on each Ethernet client PC running Windows 98, Windows 98 SE, or Windows Me:

- 1 On the Windows Desktop, click **Start**.
- 2 Select **Run**. The Run window is displayed.
- 3 Type **winipcfg.exe** and click **OK**. The IP Configuration window is displayed:

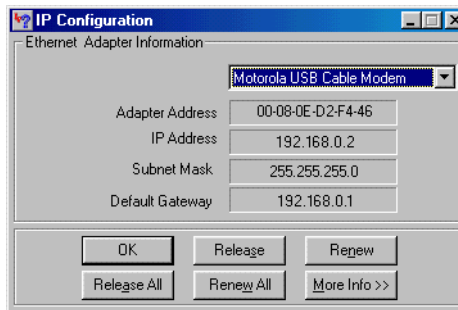

- 4 Click the **Renew** button to obtain an IP address for the PC from the DHCP server on the SBG940.

Obtaining an IP Address in Windows 2000 or Windows XP

You must do the following on each Ethernet client PC running Windows 2000 or Windows XP:

- 1 On the Windows Desktop, click **Start**.
- 2 Select **Run**. The Run window is displayed.
- 3 Type **cmd** and click **OK** to display a command prompt window.
- 4 Type **ipconfig /renew** and press **ENTER** to obtain an IP address for the PC from the DHCP server on the SBG940.
- 5 Type **exit** and press **ENTER** to return to Windows.

Obtaining an IP Address on Macintosh or UNIX Systems

Follow the instructions in your user manual.

Connecting a PC to the USB Port

You can connect a single PC running Windows 98, Windows XP, Windows Me, or Windows 2000 to the SBG940 USB port.

Caution!



Before plugging in the USB cable, be sure the SBG940 Installation CD-ROM is inserted in the PC CD-ROM drive.

To connect a PC to the USB port:

- 1 Insert the *SBG940 Installation* CD-ROM in the CD-ROM drive.
- 2 Install the USB driver following the appropriate procedure for “[Setting Up a USB Driver](#)”.
- 3 Connect the USB cable to the USB port on the SBG940 [Rear Panel](#).
- 4 Connect the other end to the USB port on the computer.

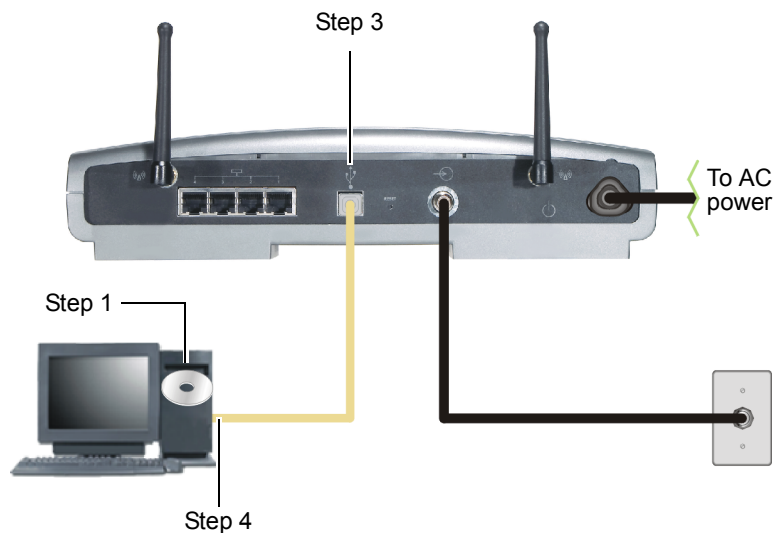

Wall Mounting

If you mount the unit on the wall, you must:

- Locate the unit as specified by the local or national codes governing residential or business cable TV and communications services.
- Follow all local standards for installing a network interface unit/network interface device (NIU/NID).

If possible, mount the unit to concrete, masonry, a wooden stud, or other very solid wall material. Use anchors if necessary; for example, if you must mount the unit on drywall.

To mount your SBG940 on the wall:

- 1 Print the [Wall Mounting Template](#) on page 23.

Go to page 23 and click the **Print** icon or choose **Print** from the **File** menu to display the Print dialog box. (The following image is from Adobe Acrobat Reader® version 4.0 running on Windows 2000; there may be slight differences in your version.)

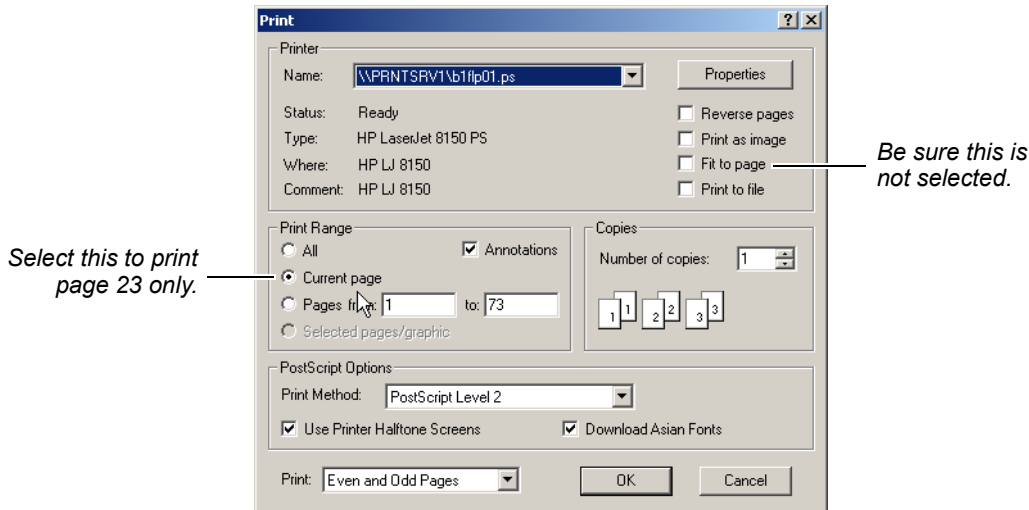

*Be sure you print the template at 100% scale. Be sure **Fit to page** is not selected.*

To print the template *only*, select **Current page** as the Print Range.

Click the **OK** button to print the template.

- 2 Measure the printed template with a ruler to ensure that it is the correct size.
- 3 Use a center punch to mark the center of the holes.
- 4 On the wall, locate the marks for the mounting holes.

Caution!



Before drilling holes, check the structure for potential damage to water, gas, or electric lines.

- 5 Drill the holes to a depth of at least 1¹/₂ inches (3.8 cm).

- 6 If necessary, seat an anchor in each hole.

Use $M5 \times 38 \text{ mm}$ (#10-16 $\times 1\frac{1}{2}$ inch) screws with a flat underside and maximum screw head diameter of 10.5 mm to mount the SBG940.

- 7 Using a screwdriver, turn each screw until part of it protrudes from the wall, as shown:

- There must be .16 inches (4.0 mm) between the wall and the underside of the screw head.
- The maximum distance from the wall to the top of the screw head is 7.6 mm (.3 in).

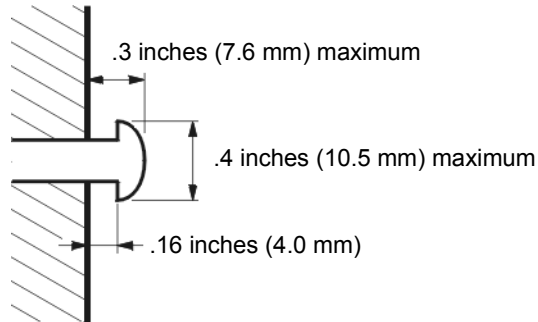

- 8 Place the SBG940 so the keyholes on the back of the unit are aligned above the mounting screws.
Be sure you do not damage the antennas.
- 9 Slide the SBG940 down until it stops against the top of the keyhole opening.

Wall Mounting Template

You can print this page to use as a wall mounting template.

Be sure you print it at 100% scale. In Acrobat Reader, be sure that Fit To Page is not selected in the Print dialog box.

Measure the printed template with a ruler to ensure that it is the correct size.

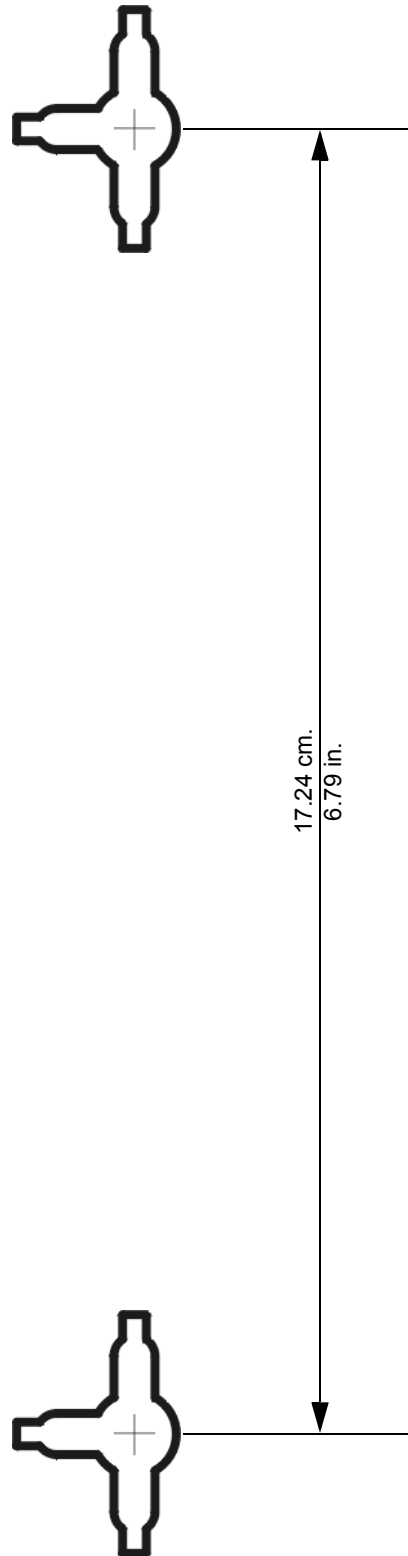

❖ Basic Configuration

The following sections provide information about basic SBG940 configuration:

- [Starting the SBG940 Setup Program](#)
- [Changing the Default Password](#)
- [Getting Help](#)
- [Setting the Firewall Policy](#)
- [Gaming Configuration Guidelines](#)

For more advanced configuration information, see “[Configuring TCP/IP](#)”, “[Setting Up Your Wireless LAN](#)”, or “[Setting Up a USB Driver](#)”.

For normal operation, you do not need to change most default settings. The following caution statements summarize the issues you must be aware of:

Caution!



To prevent unauthorized configuration, change the default password *immediately* when you first configure the SBG940. See “[Changing the Default Password](#)”.

Firewalls are not foolproof. Choose the most secure firewall policy you can. See “[Setting the Firewall Policy](#)”.

If you are using a wired LAN only and have no wireless clients, be sure you disable the wireless interface by turning off [Enable Wireless Interface](#) on the [Wireless > NETWORK Page](#).

For a wireless LAN only, be sure you follow the instructions in “[Setting Up Your Wireless LAN](#)”.

Starting the SBG940 Setup Program

- 1 On a computer wired to the SBG940 over Ethernet or USB, open a web browser. *Do not attempt to configure the SBG940 over a wireless connection.*
- 2 In the Address or Location field, type **http://192.168.100.1** or **http://192.168.0.1** and press **ENTER** to display the Log In window:

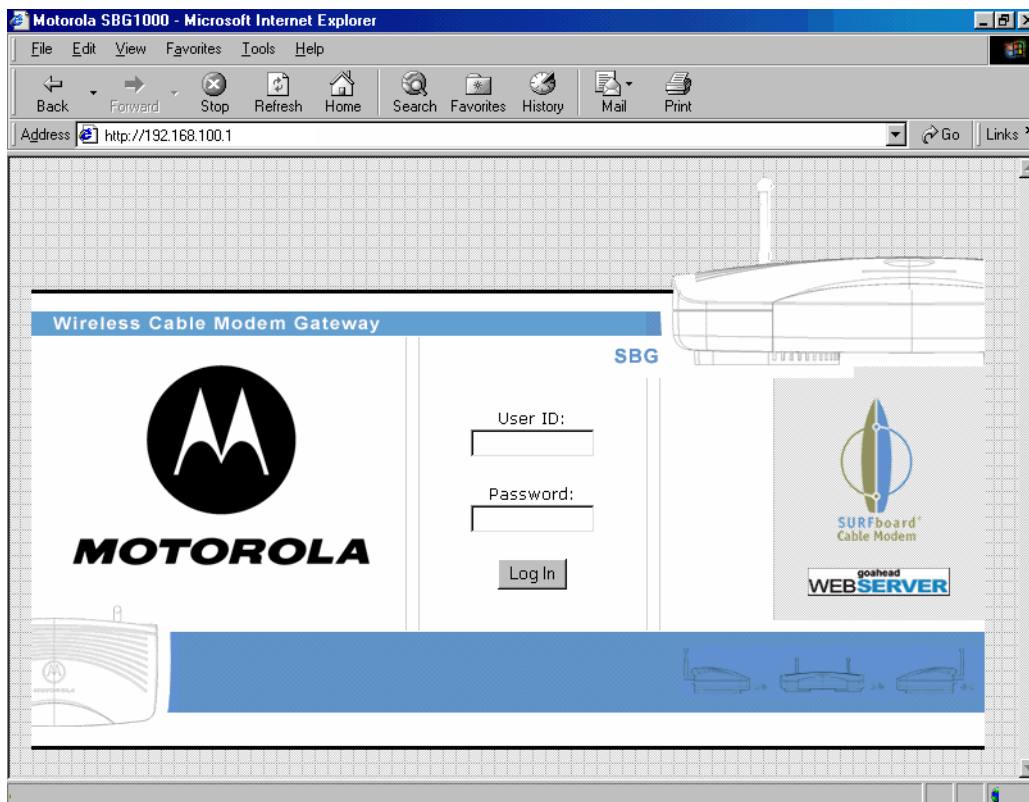

- 3 In the **User ID** field, type the **User Name**; the default is “admin” (this field is case sensitive).
- 4 In the **Password** field, type the **Password**; the default is “motorola” (this field is case sensitive).

5 Click **Log In** to display the SBG940 user configuration and status windows:

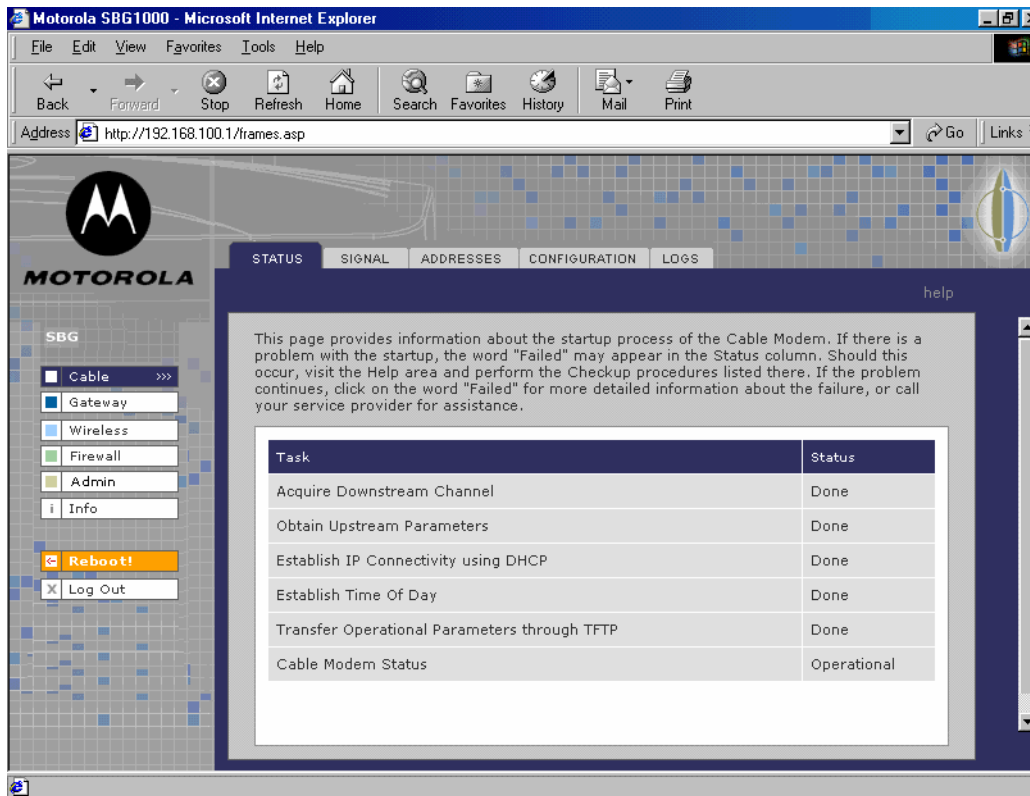

Click To Perform

- Cable** Configure and monitor the cable system connection.
- Gateway** Configure and monitor the gateway preferences (see [Configuring the Gateway](#)).
- Wireless** Configure and monitor the wireless interface (see ["Setting Up Your Wireless LAN"](#)).
- Firewall** Configure and monitor the firewall (see ["Setting the Firewall Policy"](#)).
- Admin** [Changing the Default Password](#).
- Info** Display information about the SBG940 Setup Program.
- Reboot** Restart the SBG940. It is the same as pressing the reset button on the rear panel for less than five seconds.
- Log Out** Log out of the SBG940.

If you have difficulty starting the SBG940 Setup Program, see ["Troubleshooting"](#) for information.

Router is a configuration option that may appear on your window but may not be supported.

For some settings, after you edit the field and click Apply, you are warned that you must reboot for your change to take effect. Rebooting takes 10 to 15 seconds. After rebooting, you must log in again.

Changing the Default Password

Caution!



To prevent unauthorized configuration, change the default password *immediately* when you first configure the Motorola SURFboard Wireless Cable Modem Gateway.

To change the default password:

- 1 On the SBG940 Setup Program left panel, click **Admin** to display the ADMIN — basic page:

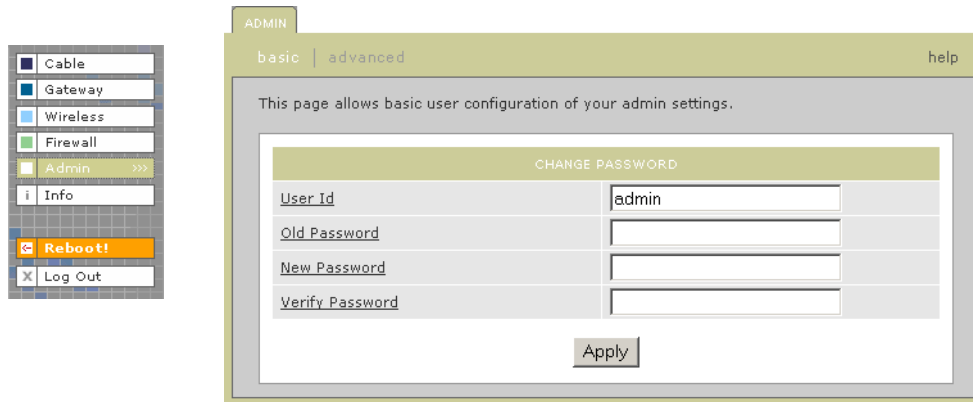

- 2 In the **Old Password** field, type the old **password**. The default password is “motorola” (this field is case sensitive).
- 3 In the **New Password** field, type the new **password**.
- 4 In the **Verify Password** field, type the new **password** again.
- 5 Click **Apply** to apply your changes.

Enabling Remote Access

You can enable remote access to the SBG940 over the Internet. You must know the **userid**, **password**, and **public IP address** assigned to your SBG940 to run the Setup Program over the Internet. Remote access is provided using a web browser on the remote client and connecting to the SBG940 web server.

To enable remote access to the SBG940:

- 1 On the SBG940 Setup Program left panel, click **Admin** to display the ADMIN — basic page.
- 2 Click **advanced** to display the ADMIN — advanced page.

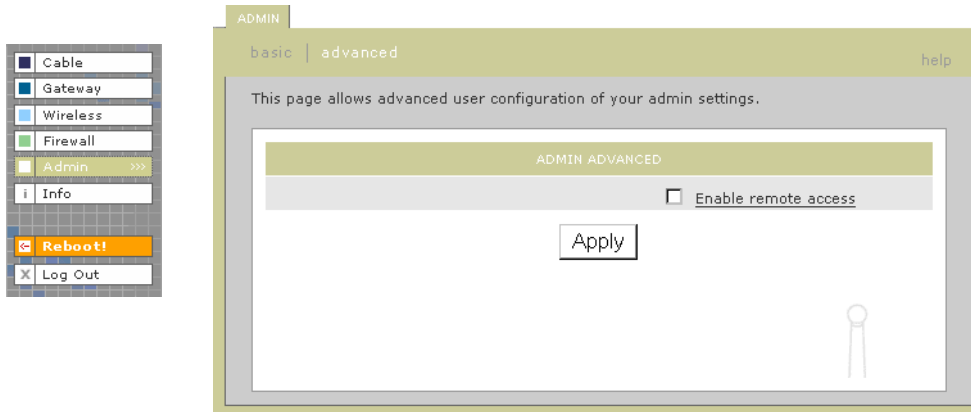

- 3 Click the box next to **Enable remote access** to enable it.
- 4 Click **Apply** to apply your change.

Getting Help

To get help on any underlined item or field, click the text. For example, if you click a field or the help button on the ADMIN — basic page, the following help is displayed:

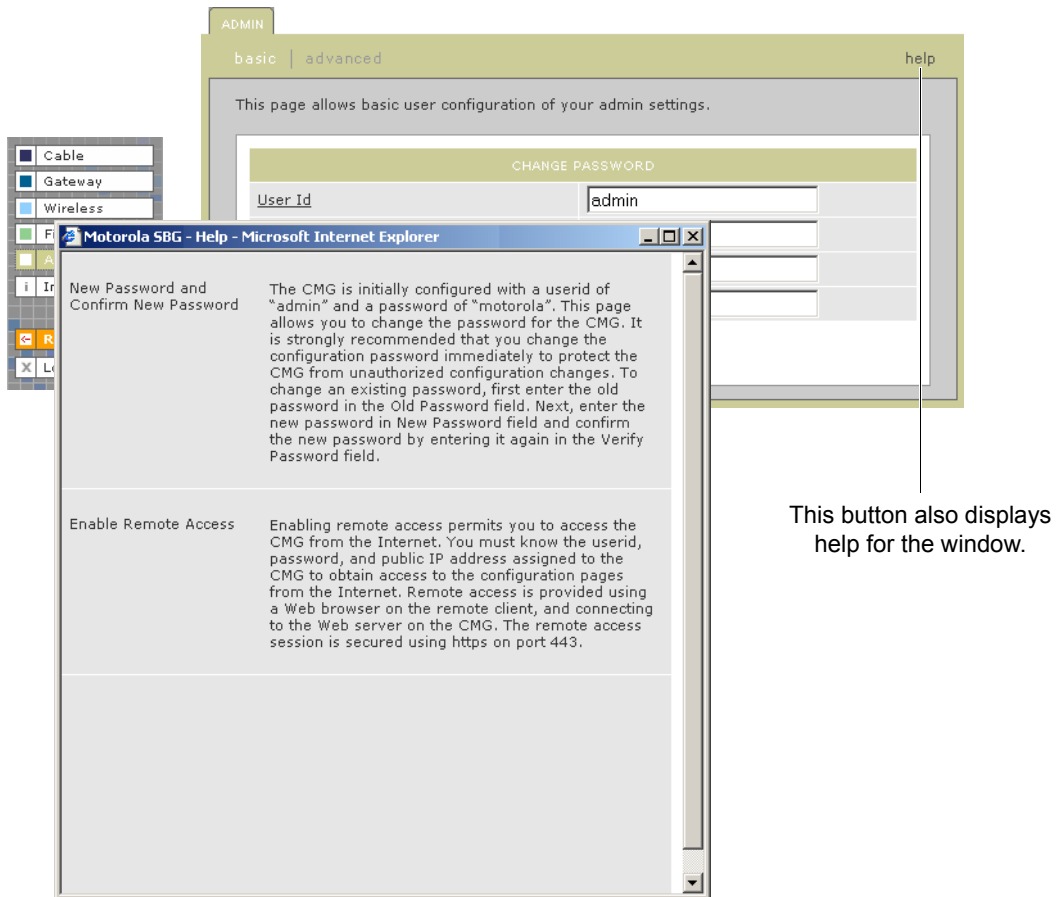

You can scroll to browse the help or click another item to display help for that item.

Setting the Firewall Policy

The SBG940 firewall protects the SBG940 LAN from undesired attacks and other intrusions from the Internet. This section describes using the Firewall > POLICY — basic page to choose one of the predefined firewall policy templates provided with the SBG940.

Caution!



Firewalls are not foolproof. Choose the most secure firewall policy you can. To enable easy network setup, the default firewall policy is None, which provides no security.

To select a predefined policy for all packets processed by the SBG940 firewall:

- 1 On the SBG940 Setup Program left panel, click **Firewall**.
- 2 Click **POLICY**.
- 3 Click **basic** to display the predefined firewall policy templates:

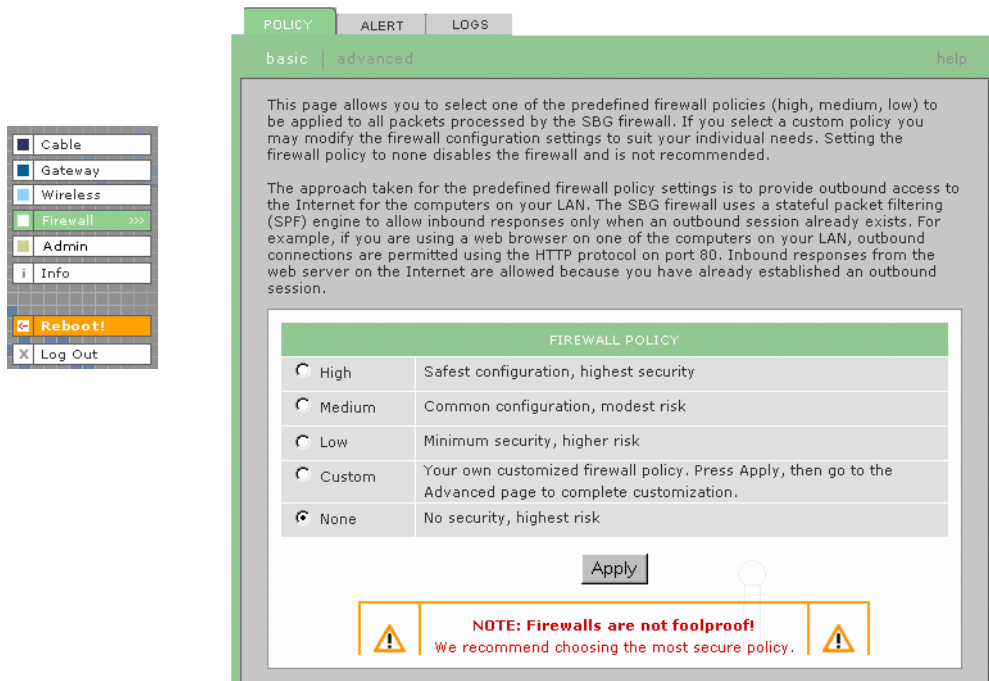

The screenshot shows the 'POLICY' configuration page for the firewall. The left sidebar has 'Firewall' selected. The main content area has tabs for 'POLICY', 'ALERT', and 'LOGS'. Under 'POLICY', there are sub-tabs for 'basic' and 'advanced'. The 'basic' tab is active, showing a table of firewall policy options. The 'None' option is selected. Below the table is an 'Apply' button and a red warning note: 'NOTE: Firewalls are not foolproof! We recommend choosing the most secure policy.'

FIREWALL POLICY	
<input type="radio"/> High	Safest configuration, highest security
<input type="radio"/> Medium	Common configuration, modest risk
<input type="radio"/> Low	Minimum security, higher risk
<input type="radio"/> Custom	Your own customized firewall policy. Press Apply, then go to the Advanced page to complete customization.
<input checked="" type="radio"/> None	No security, highest risk

- 4 Select the most secure firewall policy you can:

- High** The safest predefined firewall policy template, providing the highest security. *We recommend this setting.*
- Medium** A predefined firewall policy template providing a common configuration having modest risk.
- Low** A predefined firewall policy template providing minimum security, with a higher risk of intrusions.
- Custom** You may need to create a custom firewall policy on the [Firewall > POLICY — advanced Page](#). *Do not create a custom policy unless you have the necessary expertise and the need to do so.*
- None** Disables the firewall. To enable easy network setup, it is the default. *After you set up your network, use High, Medium, or Low to improve your security.*



- 5 Click **Apply** to apply your changes.

After you edit some fields and click Apply, you are warned that you must reboot for your change to take effect. Rebooting takes 10 to 15 seconds. After rebooting, you must log in again.

If you have the need, you can:

- View the rules for the High, Medium, or Low predefined policy templates or create a custom policy on the [Firewall > POLICY — advanced Page](#)
- Configure a firewall alert on [Firewall > ALERT — basic Page](#) and [Firewall > ALERT — email Page](#)
- View the firewall logs on the [Firewall > LOGS Page](#)

For information about how the firewall can affect gaming, see “[Gaming Configuration Guidelines](#)”.

The predefined policies provide outbound Internet access for computers on the SBG940 LAN. The SBG940 firewall uses [stateful inspection](#) to allow inbound responses when there already is an outbound session running corresponding to the data flow. For example, if you use a web browser, outbound HTTP connections are permitted on port 80. Inbound responses from the Internet are allowed because an outbound session is established.

When required, you can configure the SBG940 firewall to allow inbound packets without first establishing an outbound session. You also need to configure a port forwarding entry on the [Gateway > PORT FORWARDING — config Page](#) or a DMZ client on the [Gateway > LAN — nat config Page](#).

Firewall > POLICY — advanced Page

Do not create a custom firewall policy unless you have the necessary expertise and the need to do so. Instead, select one of the predefined policy templates as described in “Setting the Firewall Policy”.

To create a custom firewall policy, first select **Custom** and click **Apply** on the Firewall > POLICY — basic Page. Then use this page to configure a custom firewall policy:

- Cable
- Gateway
- Wireless
- Firewall >>>
- Admin
- Info
- Reboot!
- Log Out

POLICY
ALERT
LOGS

basic | advanced
help

This page allows you to construct a custom firewall policy by setting all necessary configuration parameters.

NEW FILTER ENTRY

Port ID	<input type="text"/>
Enable	<input type="checkbox"/>
Allowed Protocol	<input type="text" value="IP"/>
Port Range	<input type="text" value="0"/> : <input type="text" value="0"/>
Protocol Number	<input type="text"/>
Allow Inbound	<input type="checkbox"/>
Allow Outbound	<input type="checkbox"/>

FIREWALL POLICY							
Port ID	Enable	Port Range	Allowed Protocol	Allow IB	Allow OB	Protocol #	Delete
DNS	<input type="checkbox"/>	12:12	UDP	Yes	Yes	0	<input type="checkbox"/>
FTP	<input checked="" type="checkbox"/>	90:90	TCP	Yes	Yes	0	<input type="checkbox"/>
Telnet	<input checked="" type="checkbox"/>	700:700	UDP/TCP	No	Yes	0	<input type="checkbox"/>
ICMP	<input checked="" type="checkbox"/>	1010:1010	UDP/TCP	Yes	No	0	<input type="checkbox"/>
HTTPS	<input checked="" type="checkbox"/>	80:80	IP	Yes	Yes	5	<input type="checkbox"/>

FIREWALL POLICY TEMPLATE

Applying a Policy Template will erase previously defined customizations.

Policy Template

To base the custom policy on a predefined firewall policy template, choose High, Medium, or Low in the **Policy Template** field and click **Apply Policy Template**.

Firewall > POLICY — advanced page fields

Field	Description
NEW FILTER ENTRY	Use these fields to set up one or more custom firewall filters, <i>if you have the necessary expertise</i> .
Port ID	Type the protocol being filtered.
Enable	Select this box to enable firewall policy filtering for the port.
Allowed Protocol	Select the allowed protocols from the drop-down list.
Port Range (From:To)	Sets the port range, which must contain all ports required by the protocol.
Protocol Number	Sets the protocol number of the IP packets to allow.
Allow Inbound	Enables you to specify the port(s) on which inbound packets can pass through the firewall from the Internet to your LAN.
Allow Outbound	Enables you to specify the port(s) on which outbound packets can pass through the firewall from your LAN to the Internet. Stateful inspection ensures appropriate responses for outbound sessions.
Add	Click to add the new filter. It is displayed on the FIREWALL POLICY table.
FIREWALL POLICY Table	Lists your custom firewall filters.
Enable	Select this box to enable firewall policy filtering for the port.
Delete	Select the Delete box to delete the filter.
Apply	Click to apply your changes.
FIREWALL POLICY TEMPLATE	
Policy Template	You can use this drop-down list to select a predefined policy template on which to base your custom template — High, Medium, or Low. These templates are described in “Setting the Firewall Policy”
Apply Policy Template	Click to apply the selected Policy Template and cancel any customizations.

Firewall > ALERT — basic Page

You can use this page to set the alert mechanism for firewall intrusion detection events.

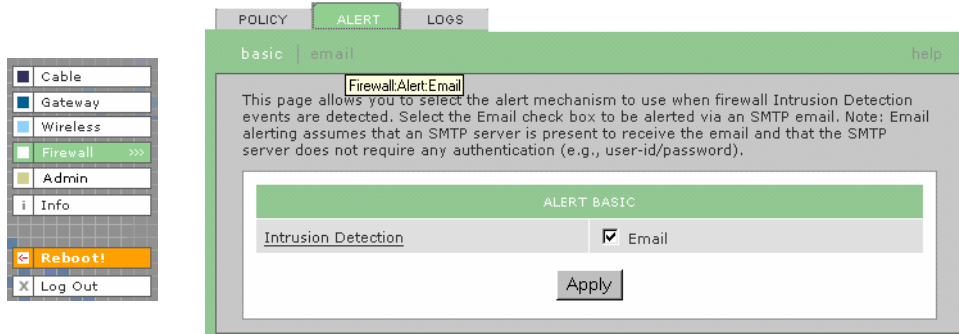

Firewall > ALERT — basic page fields

Field or Button

Description

Intrusion Detection

Select Email to be alerted through SMTP e-mail. An SMTP server that does not require any authentication such as a user name or password must be present to receive the e-mail.

Apply

Click to apply your changes.

Firewall > ALERT — email Page

You can use this page to configure the e-mail alert parameters:

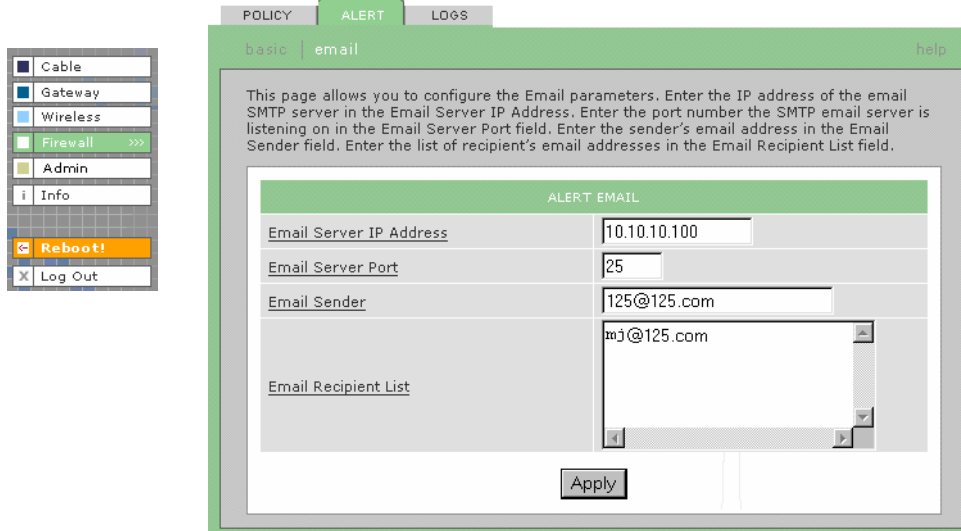

The screenshot shows the configuration interface for email alerts. On the left is a navigation menu with options: Cable, Gateway, Wireless, Firewall (selected), Admin, Info, Reboot!, and Log Out. The main content area has tabs for POLICY, ALERT, and LOGS. Under the ALERT tab, there are sub-tabs for 'basic' and 'email'. The 'email' sub-tab is active, displaying a form titled 'ALERT EMAIL'. The form includes the following fields:

- Email Server IP Address:** 10.10.10.100
- Email Server Port:** 25
- Email Sender:** 125@125.com
- Email Recipient List:** m3@125.com

An 'Apply' button is located at the bottom of the form. A help link is visible in the top right corner of the page.

Firewall > ALERT — email page fields

Field or Button	Description
E-mail Server IP Address	Sets the e-mail server IP address in dotted-decimal format .
E-mail Server Port	Sets the e-mail server port number.
E-mail Sender	Sets the sender e-mail address.
E-mail Recipient List	Sets the list of e-mail addresses that receive alerts from the SBG940 firewall.
Apply	Click to apply your changes.

Firewall > LOGS Page

You can use this page to set which firewall events are logged.

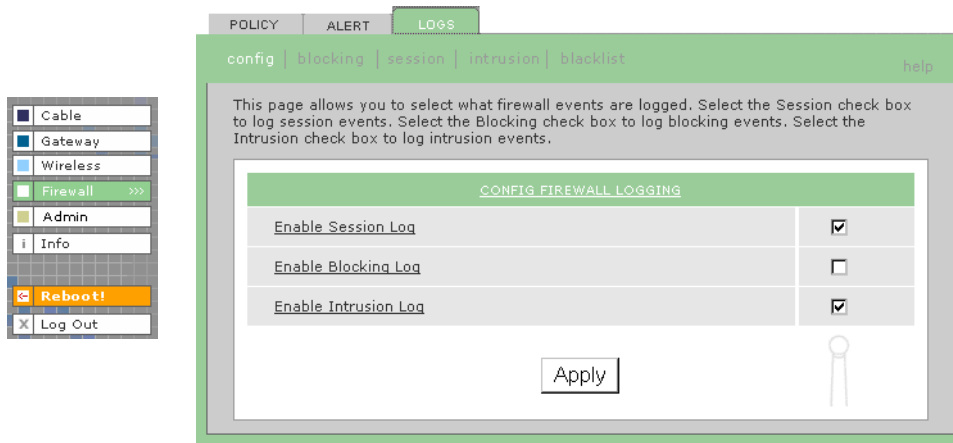

Firewall > LOGS page fields

Field or Button

Description

Enable Session Log

Select this box to log every data session from the private LAN that was authorized by the SBG940 firewall. Usually, the session log displays a history of normal data traffic. It also lists the start of sessions the firewall terminated because:

- The policy was changed
- They were eventually determined to be an intrusion or attack

To display the session log, click **session**.

Enable Blocking Log

Select this box to log inbound and outbound packets that the SBG940 firewall:

- Does not allow to pass because they use protocols and/or ports not explicitly allowed by the active policy
- Determines to be invalid because of a session or reassembly timeout

To display the blocking log, click **blocking**.

Enable Intrusion Log

Select this box to log attacks using common network intrusion tactics that the SBG940 firewall detects and stops.

To display the intrusion log, click **intrusion**.

Apply

Click to apply your changes.

If you enable the firewall, the blacklist log is always generated. Any IP address the firewall determines to have breached the active policy is added to the blacklist log. To view the blacklist log, click **blacklist**. The firewall blocks all traffic to and from a blacklisted IP address for 24 hours or until you reboot the SBG940 or manually clear the blacklist by clicking **Clear** on the Firewall > LOGS — blacklist page.

Gaming Configuration Guidelines

The following subsections provide information about configuring the SBG940 firewall and DMZ for gaming.

Configuring the Firewall for Gaming

By default, the SBG940 firewall is disabled. If, as recommended, you enable the firewall, refer to the game's documentation to ensure that the necessary ports are open for use by that game.

The pre-defined SBG940 firewall policies affect Xbox *Live*™ as follows:

- Low** Xbox *Live* data can pass through the firewall. No user action is required.
- Medium or high** To enable Xbox *Live* traffic to pass, you must configure:
- Choose Custom on the Firewall > POLICY — basic Page
 - UDP 88:88 and UDP/TCP 3074:3074 on the Firewall > POLICY — advanced Page

Configuring Port Triggers

Because the SBG940 has pre-defined port triggers for games using any of the following applications, no user action is required to enable them:

- DirectX 7 and DirectX 8
- MSN Games by Zone.com
- Battle.net®

For a list of games supported by Battle.net, visit <http://www.battle.net>.

You may need to create custom port triggers to enable other games to operate properly. If you set custom port triggers and enable the firewall, you must customize the firewall to allow traffic through those ports. To create custom port triggers, use the [Gateway > PORT TRIGGERS — custom Page](#).

Configuring a Gaming DMZ Host

Caution!



The gaming DMZ host is not protected by the firewall. It is open to communication or hacking from any computer on the Internet. Consider carefully before configuring a device to be in the DMZ.

Some games and game devices require *one* of:

- The use of random ports
- The forwarding of unsolicited traffic

For example, to connect a PlayStation® 2 for PS2® online gaming, designate it as the gaming DMZ host because the ports required vary from game to game. For these games, we recommend configuring the gaming computer or device as a gaming DMZ device.

To configure a gaming DMZ device, on the [Gateway > LAN — dhcp leases Page](#):

- 1 Reserve a private IP address for the computer or game device MAC address.
- 2 Designate the device as a DMZ device.

You can reserve IP addresses for multiple devices, but only one can be designated as the gaming DMZ at once.

Configuring the Gateway

This section describes the Gateway configuration pages in the SBG940 Setup Program:

- [Gateway > STATUS Page](#)
- [Gateway > WAN Page](#)
- [Gateway > LAN — nat config Page](#)
- [Gateway > LAN — dhcp server config Page](#)
- [Gateway > LAN — dhcp leases Page](#)
- [Gateway > PORT FORWARDING — status Page](#)
- [Gateway > PORT FORWARDING — config Page](#)
- [Gateway > PORT TRIGGERS — predefined Page](#)
- [Gateway > PORT TRIGGERS — custom Page](#)
- [Gateway > LOG Page](#)

After you edit some fields and click Apply, you are warned that you must reboot for your change to take effect. Rebooting takes 10 to 15 seconds. After rebooting, you must log in again.

Gateway > STATUS Page

This page displays the gateway status information:

- Cable
- Gateway >>>
- Wireless
- Firewall
- Admin
- Info
- ← Reboot!
- X Log Out

STATUS
WAN
LAN
PORT TRIGGERS
LOG

[help](#)

This page lists the status information for several gateway configuration parameters.

WAN Status	Data
DNS Address 1	206.19.80.10
DNS Address 2	206.19.86.10
DNS Address 3	0.0.0.0
WAN IP Address	206.19.86.131
TCP Session Wait Timeout	300 seconds
UDP Session Wait Timeout	300 seconds
ICMP Session Wait Timeout	300 seconds

LAN Status	Data
LAN IP Address	192.168.0.1
LAN Subnet Mask	255.255.255.0
MAC Address	00:08:0E:D2:F4:71
DHCP Server Enabled	Yes

DHCP LEASE TABLE					
IP Address	MAC Address	Hostname	Method	Lease Create Time	Lease Expire Time
192.168.0.2	00:C0:F0:3B:3E:9C	Micron-95	Dynamic	2003-01-14 12:54:49	2003-01-14 13:54:49

TRANSLATED ADDRESS					
WAN IP Address	WAN Port	LAN IP Address	LAN Port	Mapping Mode	Mapping Protocol
206.19.86.131	2233	192.168.0.2	2233	0	3
206.19.86.131	2228	192.168.0.2	2228	0	3

PASSTHROUGH HOST

These fields display settings that are set on the other Gateway pages. For field descriptions, see the following subsections that describe the fields on each tab.

Gateway > WAN Page

Use this page to configure the external (public) wide area network (WAN) interface:

Field	Data
Host Name	<input type="text"/>
<input checked="" type="radio"/> Enable DHCP client (obtain dynamic IP address) <input type="radio"/> Disable DHCP client (use static IP address)	
Static IP Address	206.19.86.131
Static IP Subnet Mask	255.255.255.224
WAN Default Gateway	206.19.86.129
DNS IP Address 1	206.19.80.10
DNS IP Address 2	206.19.86.10
DNS IP Address 3	0.0.0.0
TCP Session Wait Timeout	<input type="text" value="300"/> seconds
UDP Session Wait Timeout	<input type="text" value="300"/> seconds
ICMP Session Wait Timeout	<input type="text" value="300"/> seconds

Gateway > WAN page fields

Field	Description
Host Name	If the cable provider requires a hostname to access to their network, type the <i>hostname</i> they provided in this field. The default is None.
Enable DHCP Client (obtain dynamic IP address)	Enabling the DHCP client causes the wireless gateway to automatically obtain the public IP address , subnet mask , domain name , and DNS server(s). Most commonly, the DHCP client is enabled if the cable provider automatically assigns a public IP address from their DHCP server. Enable DHCP Client is selected by default.
Disable DHCP Client (use static IP address)	If the cable provider does not automatically assign a public IP address using DHCP, they must provide a static IP address . Select Disable DHCP Client. When you disable the DHCP client, you must type the static IP address, subnet mask, DNS server(s), and domain name (if necessary) in the fields provided. Disable DHCP Client is not selected by default.
Static IP Address	If Disable DHCP Client is selected, type the static <i>IP address</i> provided by the cable provider in dotted-decimal format . The default is None.
Static IP Subnet Mask	If Disable DHCP Client is selected, type the <i>subnet mask</i> associated with the static IP address in dotted-decimal format. The default is None.
WAN Default Gateway	When using a Static IP Address from the cable provider, type the default gateway <i>IP address</i> on the WAN for the SBG940 in dotted-decimal format.



Gateway > WAN page fields (continued)

Field	Description
DNS IP Address 1	The cable provider DNS server provides name-to-IP address resolution. If the cable provider does not automatically assign DNS addresses from their DHCP server, they must provide at least one DNS server IP address to enter in these fields in dotted-decimal format. The default is None.
DNS IP Address 2	
DNS IP Address 3	
TCP Session Wait Timeout	Sets the maximum time in seconds to wait before assuming a TCP session has timed out. The default is 24 hours.
UDP Session Wait Timeout	Sets the maximum time in seconds to wait before assuming a UDP session has timed out. The default is 300 seconds (5 minutes).
ICMP Session Wait Timeout	Sets the maximum time in seconds to wait before assuming an ICMP session has timed out. The default is 300 seconds (5 minutes).
Apply	Click to apply your changes.

Gateway > LAN — nat config Page

Use this page to enable NAT and add clients to the CURRENT NAT PASSTHROUGH list:

The screenshot shows the 'nat config' page with the following sections:

- LAN:** A checkbox for 'Enable NAT' and an 'Apply' button.
- NEW NAT PASSTHROUGH:** A form with a 'MAC Address' field (example: 11:22:33:aa:bb:cc) and a 'Bypass Firewall (True DMZ)' checkbox, with an 'Add' button below.
- CURRENT NAT PASSTHROUGH:** A table listing current passthrough clients.

MAC Address	Bypass Firewall	Delete
0F:0F:0F:0F:0F:00	No	<input type="checkbox"/>
0F:0F:0F:0F:0F:01	Yes	<input type="checkbox"/>
0F:0F:0F:0F:0F:02	No	<input type="checkbox"/>
0F:0F:0F:0F:0F:03	Yes	<input type="checkbox"/>

Gateway > LAN — nat config page fields

Field or Button

Description

LAN

Enable NAT

If enabled, the single HFC IP Address (public IP address) assigned by the cable provider is mapped to many private IP addresses on the SBG940 LAN.

Apply

Click to apply your changes. You must reboot the SBG940.

NEW NAT PASSTHROUGH

Specifies up to 32 computers as passthrough clients not subject to NAT, using their MAC addresses.

MAC Address

Type the passthrough client MAC address. The format is 16 hexadecimal numerals.

Bypass Firewall (True DMZ)

Select this box to set the NAT passthrough computer as a DMZ client. *Use this setting with extreme caution because a DMZ client is completely open to Internet hackers.*

Add

Click to add the MAC address to the CURRENT NAT PASSTHROUGH list.

CURRENT NAT PASSTHROUGH

Lists the computers on the LAN that are configured for NAT passthrough.

Delete

Click to delete the selected MAC address from the NAT passthrough list.

Gateway > LAN — dhcp server config Page

Only experienced network administrators should use this page to perform advanced DHCP server configuration:

The screenshot shows the 'dhcp server config' page. The left sidebar contains navigation options: Cable, Gateway, Wireless, Firewall, Admin, Info, Reboot!, and Log Out. The main content area has tabs for 'nat config', 'dhcp server config', and 'dhcp leases'. A note states: 'This page allows you to configure the SBG DHCP server parameters for your private LAN. Note: Only experienced network users should modify these parameters.' The configuration fields are as follows:

DHCP_SERVER	
LAN IP Address	192.168.0.1
LAN IP Subnet Mask	255.255.255.0
Starting IP Address	192 . 168 . 0 . 2
# of DHCP Users	253
DHCP Server Lease Time	3600 seconds
Domain Name	domain.name
Time to Live	64 hops
Interface Maximum Transmission Unit	0 bytes

An 'Apply' button is located at the bottom right of the configuration area.

CAUTION!



Do not modify these settings unless you are an experienced network administrator with strong knowledge of IP addressing, subnetting, and DHCP.

Gateway > LAN — dhcp server config page fields

Field	Description
LAN IP Address	You can type the <i>IP address</i> of the SBG940 for your private LAN. The default is 192.168.0.1.
LAN IP Subnet Mask	Displays the subnet mask in dotted-decimal format. The default is 255.255.255.0.
Starting IP Address	Enter the starting <i>IP address</i> to be assigned by the SBG940 DHCP server to clients in dotted-decimal format. The default is 192.168.0.2.
# of DHCP Users	Sets the <i>number</i> of clients for the SBG940 DHCP server to assign a private IP address. There are 253 possible client addresses. The default is 253.
DHCP Server Lease Time	Sets the <i>time</i> in seconds that the SBG940 DHCP server leases an IP address to a client. The default is 3600 seconds (60 minutes).
Domain Name	Sets the <i>domain name</i> for the SBG940 LAN. The default is None.
Time To Live	Sets the <i>TTL</i> (hop limit) for outbound packets. The default is 64.
Interface Maximum Transmission Unit	Sets the SBG940 LAN MTU in bytes. The minimum is 68 bytes. The default is 1500 bytes.
Apply	Click to apply your changes. You must reboot the SBG940.

Gateway > LAN — dhcp leases Page

Use this page to configure DHCP leases:

Gateway > LAN — dhcp leases page fields

Field

Description

GAMING DMZ

Enable Gaming DMZ

Select this box to designate the selected computer or gaming device as the gaming DMZ host. For more information, see “[Configuring a Gaming DMZ Host](#)”. This can be useful if you have difficulties running certain applications; typically gaming applications.

(Gaming) DMZ Host

The gaming DMZ host is a computer with a reserved IP address designated as the default DMZ host. Only one gaming DMZ host can be active at once.

The gaming DMZ host is not protected by the firewall. It is open to communication or hacking from any computer on the Internet. Consider carefully before configuring a computer to be in the DMZ.

The benefit of using a gaming DMZ host instead of a NAT passthrough host is that a gaming DMZ host does not require a public IP address as does a NAT passthrough host. If the application requires a public IP address, configure the computer for NAT passthrough on the [Gateway > LAN — nat config Page](#).

Gateway > LAN — dhcp leases page fields (continued)

Field	Description
RESERVE NEW IP ADDRESS	You can reserve up to 32 IP addresses assigned by the SBG940 DHCP server for specific LAN clients. For example, to ensure that they always receive the same private IP address, you can reserve IP addresses for a private FTP server or gaming DMZ device.
MAC Address	Type the MAC address of the DHCP client for which a reserved IP address is required. The format is 16 hexadecimal numerals.
IP Address	Sets the host portion of the reserved IP address for the LAN client having the specified MAC address. When the LAN client requests an IP address, the SBG940 DHCP server assigns the client this IP address.
Host Name	If your ISP requires a hostname to access their network, enter the hostname provided to you in the Host Name field.
Add	Click Add to reserve a new IP address.
CURRENTLY RESERVED IP ADDRESSES	Displays all DHCP clients having reserved IP addresses.
MAC Address	Displays the client MAC address.
IP Address	Displays its reserved IP address
Host Name	Displays its host name.
Method	Displays dynamic and static lease status. Add or delete dynamic or static lease status in this field.
Delete	Click this box to remove the reserved IP address for the client.
Delete	Click this button to remove the reserved IP addresses for clients designated by the Delete box.

Gateway > PORT FORWARDING — status Page

Use this page to display the configured port forwarding entries on the SBG940 LAN. The fields are the same as on the [Gateway > PORT FORWARDING — config Page](#):

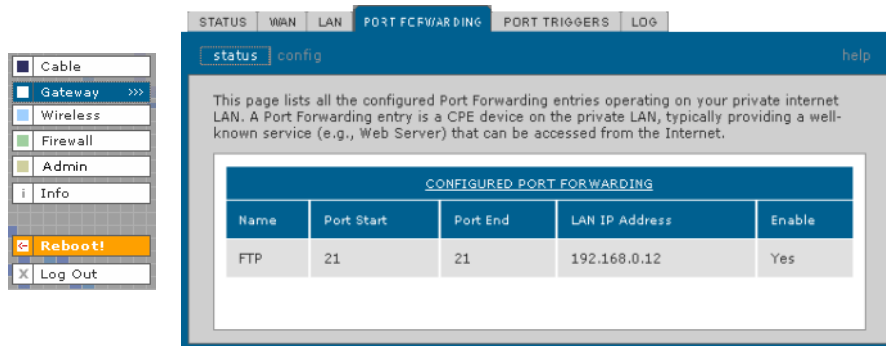

The screenshot shows the web interface with a navigation menu on the left and a main content area. The main content area has tabs for STATUS, WAN, LAN, PORT FORWARDING (selected), PORT TRIGGERS, and LOG. Below the tabs, there are buttons for 'status', 'config', and 'help'. A descriptive paragraph explains that the page lists configured port forwarding entries. Below this is a table titled 'CONFIGURED PORT FORWARDING' with the following data:

Name	Port Start	Port End	LAN IP Address	Enable
FTP	21	21	192.168.0.12	Yes

Gateway > PORT FORWARDING — config Page

Use this page to configure up to 32 virtual servers:

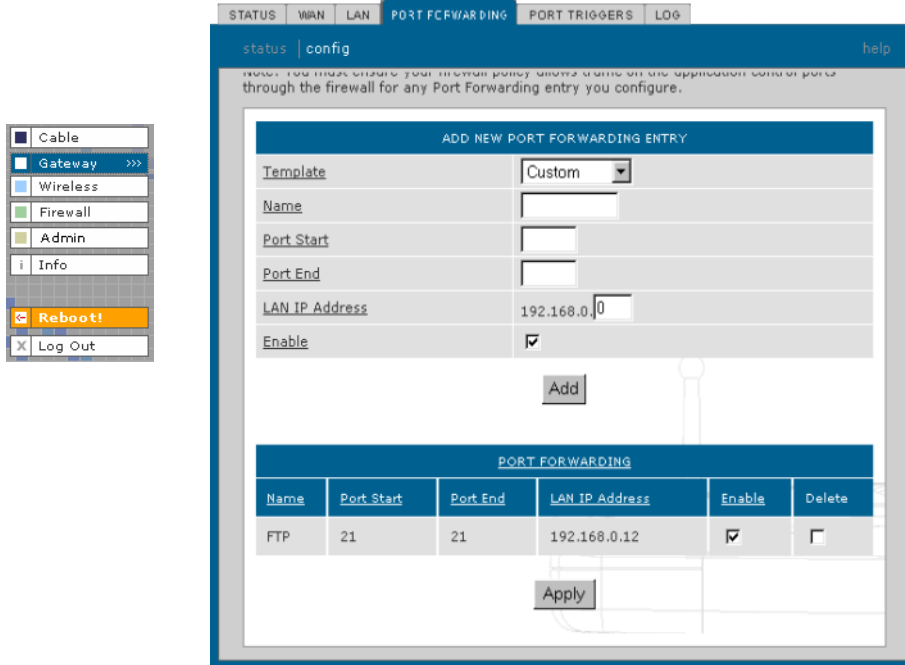

Gateway > PORT FORWARDING — config page fields

Field	Description
ADD NEW PORT FORWARDING ENTRY	You can configure up to 32 virtual servers. If you select Custom, you must set the Name, Port Start, Port End, and LAN IP Address.
Template	If you select a predefined template such as HTTP or FTP, the Name, Port Start, Port End values are provided. You only need to enter LAN IP Address and change default values only if necessary.
Name	Type a unique identifier for the custom virtual server. The typical practice is to use the protocol as a unique identifier (for example "ftp").
Port Start	Sets the LAN internal interface port or the start of a port range. Inbound Internet connection requests are statically mapped to this port. The ports used by some common applications are: <ul style="list-style-type: none"> • FTP 20, 21 • HTTP 80 • NTP 123 • Secure Shell 22 • SMTP e-mail 25 • Telnet 23
Port End	If a range of ports is required, sets the end of the port range.

Gateway > PORT FORWARDING — config page fields (continued)

Field	Description
LAN IP Address	Sets the private LAN IP address for the port forwarding page. An Internet user must know the public IP address to access any port forwarding entry you define on the private LAN.
Enable	Select this box to enable the port forwarding entries to be accessed through NAT.
Add	Click to add the virtual server to the PORT FORWARDING list.
PORT FORWARDING	Displays the configured custom virtual servers.

Gateway > PORT TRIGGERS — predefined Page

When you run a PC application that accesses the Internet, it communicates with a computer on the Internet. In some applications, especially gaming, the computer on the Internet also communicates with your PC. Because NAT does not normally allow these incoming connections, the SBG940 supports port triggering.

The SBG940 is preconfigured with port triggering for common applications. You can also configure additional port triggers if needed. Configuring port triggers for an application requires:

- The application transport protocol — TCP or UDP
- The application port number

You can use the default values for the remaining parameters.

Only one computer at a time connected to the SBG940 can use an application requiring port triggering. Use this page to view predefined port triggers:

Name	Enable	Protocol	Port Range	Session Chaining	Session Interval	Address Replace	Multi Host
DirectX7 (TCP)	<input checked="" type="checkbox"/>	TCP	47624:47624	TCP/UDP	600	Disable	Yes
DirectX7 (UDP)	<input checked="" type="checkbox"/>	UDP	47624:47624	TCP/UDP	600	Disable	Yes
DirectX8 (UDP)	<input checked="" type="checkbox"/>	UDP	6073:6073	TCP/UDP	600	Disable	Yes
DirectX8 (TCP)	<input checked="" type="checkbox"/>	TCP	6073:6073	TCP/UDP	600	Disable	Yes
MS zone.com (TCP)	<input checked="" type="checkbox"/>	TCP	6667:6667	TCP/UDP	600	Disable	Yes
MS zone.com (UDP)	<input checked="" type="checkbox"/>	UDP	6667:6667	TCP/UDP	600	Disable	Yes
Battle.n et1 (TCP)	<input checked="" type="checkbox"/>	TCP	6112:6112	TCP/UDP	600	Disable	Yes
Battle.n et2 (UDP)	<input checked="" type="checkbox"/>	UDP	6112:6112	TCP/UDP	600	Disable	Yes
Battle.n et3 (TCP)	<input checked="" type="checkbox"/>	TCP	4000:4000	TCP/UDP	600	Disable	Yes
Battle.n et4 (UDP)	<input checked="" type="checkbox"/>	UDP	4000:4000	TCP/UDP	600	Disable	Yes
Quicktime RTSP TCP	<input checked="" type="checkbox"/>	TCP	554:554	TCP/UDP	600	Disable	Yes
Netmeeting H-323	<input checked="" type="checkbox"/>	TCP	1720:1720	TCP/UDP	600	TCP	Yes
Net2Phone	<input checked="" type="checkbox"/>	UDP	6801:6801	TCP/UDP	600	Disable	Yes
MSN Msg	<input checked="" type="checkbox"/>	TCP	1863:1863	TCP/UDP	600	Disable	No
AOL IM	<input checked="" type="checkbox"/>	TCP	5190:5190	TCP/UDP	600	Disable	No

Gateway > PORT TRIGGERS — predefined page fields

Field	Description
Name	Displays the unique name for the port triggers. This is typically the protocol name.
Enable	Select this box to activate the port triggers for the predefined application.
Protocol	Displays the transport protocol for the port trigger — TCP or UDP.
Port Range	Displays the port range (From/To) for the port trigger.
Session Chaining	Displays the session chaining selection for the port trigger — Disable, TCP, or TCP/UDP.
Session Interval	Displays the session interval set for the port trigger.
Address Replace	Displays the address replacement method for the port trigger.
Multi Host	Displays the multi host selection for the port trigger.

Gateway > PORT TRIGGERS — custom Page

Use this page to create a custom port trigger:



Gateway > PORT TRIGGERS — custom page fields

Field

Description

ADD NEW SPECIAL APPLICATION

Name	Enter the unique name for the port trigger. This is typically the protocol.
Enable	Select this box to enable the custom port trigger.
Protocol	Sets the transport protocol for the port trigger — TCP or UDP.
Port Range (From:To)	Sets the port range for the port trigger. Type the start of the range in the left field and the end in the right field.
Session Chaining	Enable session chaining if the application needs to open one or more ports in different ranges to operate properly. The options are Disable, TCP, or TCP/UDP.
Session Interval	Sets the session interval for the application: <ul style="list-style-type: none"> • If the port triggers detect traffic on the Port Range within the Session Interval, it is considered to be related to the initial session. • If the port triggers detect traffic on the Port Range after the Session Interval expires, it is considered to be a new and unique session.
Address Replace	Sets the address replacement method for the application.
Multi Host	Select if appropriate for the application.
Add	Click to add the port trigger to the PORT TRIGGERS TABLE.

Gateway > PORT TRIGGERS — custom page fields (continued)

Field	Description
PORT TRIGGERS TABLE	Lists all port triggers you defined and their parameters.
Priority Port	Select the port to have a priority status.

Gateway > LOG Page

Use this page to view detailed information about the gateway:

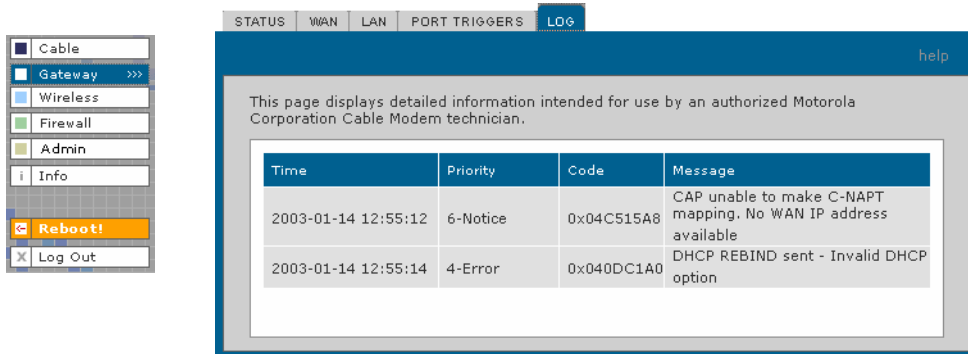

The screenshot shows the Gateway configuration interface with the 'LOG' tab selected. A sidebar on the left contains navigation options: Cable, Gateway (selected), Wireless, Firewall, Admin, Info, Reboot!, and Log Out. The main content area displays a table of log entries with the following data:

Time	Priority	Code	Message
2003-01-14 12:55:12	6-Notice	0x04C515A8	CAP unable to make C-NAPT mapping. No WAN IP address available
2003-01-14 12:55:14	4-Error	0x040DC1A0	DHCP REBIND sent - Invalid DHCP option

Gateway > LOG page fields

Field	Description
Time	The date and time in the format yyyy-mm-dd hh:mm:ss
Priority	Indicates the importance of the message.
Code	Displays a code associated with the message.
Message	Describes the event.

❖ Configuring TCP/IP

You must be sure all client computers are configured for [TCP/IP](#) (a protocol for communication between computers). Perform *one* of:

- [Configuring TCP/IP in Windows 95, Windows 98, or Windows Me](#)
- [Configuring TCP/IP in Windows 2000](#)
- [Configuring TCP/IP in Windows XP](#)
- Follow the instructions in your Macintosh or UNIX user manual

After configuring TCP/IP, perform *one* of the following to verify the [IP address](#):

- [Verifying the IP Address in Windows 95, Windows 98, or Windows Me](#)
- [Verifying the IP Address in Windows 2000 or Windows XP](#)
- Follow the instructions in your Macintosh or UNIX user manual

Configuring TCP/IP in Windows 95, Windows 98, or Windows Me

- 1 On the Windows Desktop, click **Start**.
- 2 Select **Settings** and then **Control Panel** from the pop-up menus to display the Control Panel window:

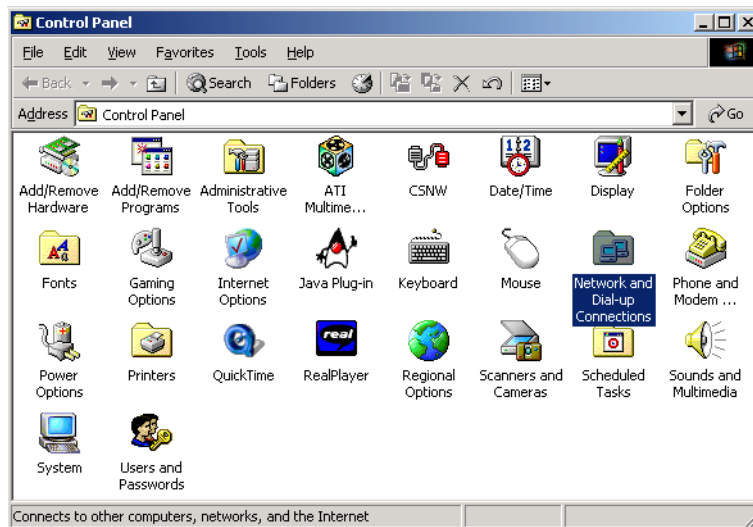

- 3 Double-click the **Network** icon to display the Network window:

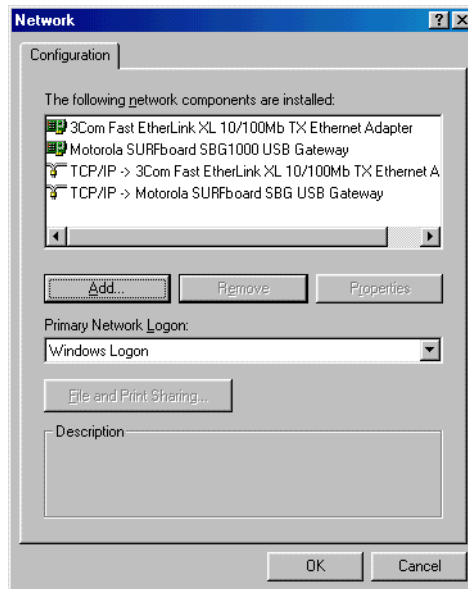

Although your SBG model number may be different than in the images in this guide, the procedure is the same.

- 4 Select the **Configuration** tab.
- 5 Verify that TCP/IP is installed for the adapter used to connect to the SBG940. If TCP/IP is installed, skip to step 10. If TCP/IP is not installed for the adapter, continue with step 6.
- 6 Select the adapter to use for the SBG940 connection and click **Add**. The Select Network Component Type window is displayed:

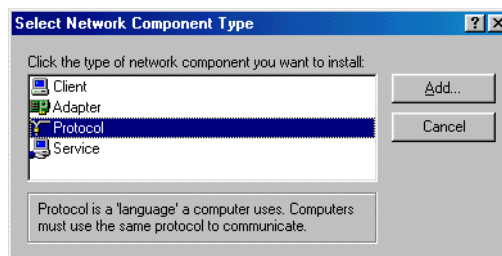

- 7 Click **Protocol** and click **Add**. The Select Network Protocol window is displayed:

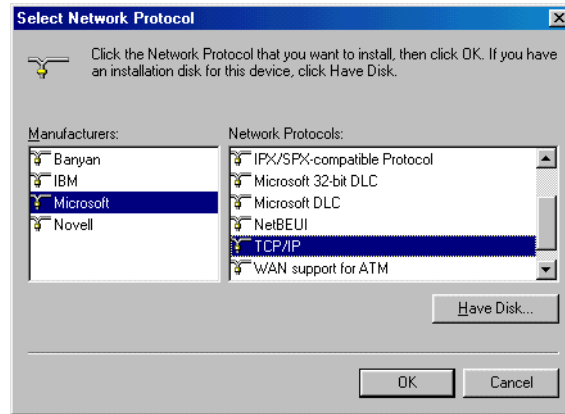

- 8 Click **Microsoft** in the Manufacturers section and click **TCP/IP** in the Network Protocols section.
- 9 Click **OK**.
- 10 Click **TCP/IP** on the Network window. If there is more than one TCP/IP entry, choose the one for the Ethernet card or USB port connected to the SBG940.
- 11 Click **Properties**. The TCP/IP Properties window is displayed:

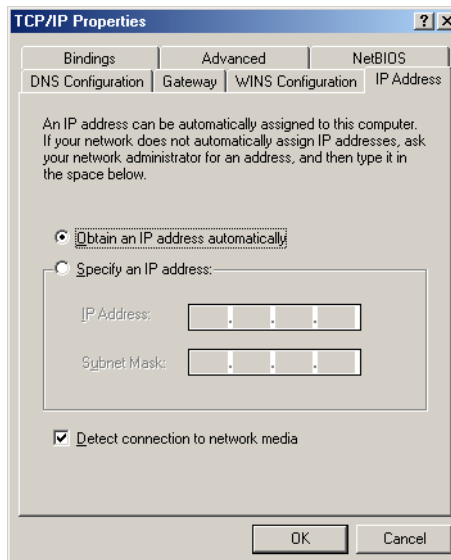

- 12 Click the **IP Address** tab.
- 13 Click **Obtain an IP address automatically**.
- 14 Click **OK** to accept the TCP/IP settings.
- 15 Click **OK** to close the Network window.
- 16 Click **OK** when prompted to restart the computer and click **OK** again.

When you complete TCP/IP configuration, go to [“Verifying the IP Address in Windows 95, Windows 98, or Windows Me”](#).

Configuring TCP/IP in Windows 2000

- 1 On the Windows Desktop, click **Start**.
- 2 Select **Settings** and then **Control Panel** from the pop-up menus to display the Control Panel window:

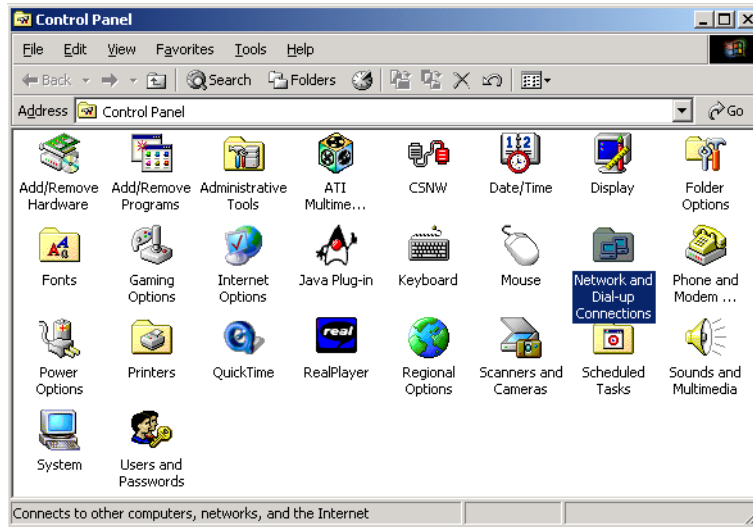

- 3 Double-click the **Network and Dial-up Connections** icon to display the Network and Dial-up Connections window:

