

**INSTRUCTION MANUAL**

A preliminary draft copy of the Users Manual follows:

The following phrase will be added to the users manual prior to printing:

**Caution:** Changes or modifications made in the radio phone, not expressly approved by Motorola, will void the user's authority to operated the equipment.



# *MOTOMANUAL*

V191  
GSM

[motorola.com](http://motorola.com)

# HELLOMOTO

---

Introducing your new Motorola V191 GSM wireless phone. Here's a quick anatomy lesson.

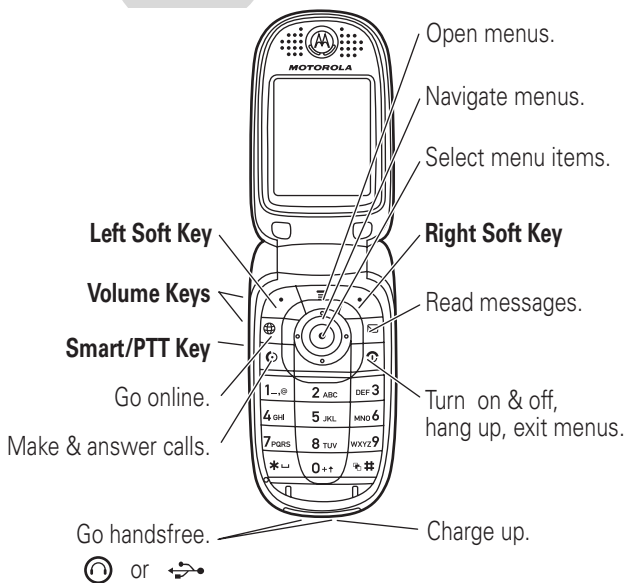

For Push to Talk (PTT) details, see page 50.

Motorola, Inc.  
Consumer Advocacy Office  
1307 East Algonquin Road  
Schaumburg, IL 60196

[www.hellomoto.com](http://www.hellomoto.com)

Certain mobile phone features are dependent on the capabilities and settings of your service provider's network. Additionally, certain features may not be activated by your service provider, and/or the provider's network settings may limit the feature's functionality. Always contact your service provider about feature availability and functionality. All features, functionality, and other product specifications, as well as the information contained in this user's guide are based upon the latest available information and are believed to be accurate at the time of printing. Motorola reserves the right to change or modify any information or specifications without notice or obligation.

MOTOROLA and the Stylized M Logo are registered in the US Patent & Trademark Office. Java and all other Java-based marks are trademarks or registered trademarks of Sun Microsystems, Inc. in the U.S. and other countries. All other product or service names are the property of their respective owners.

© Motorola, Inc., 2005.

## **Software Copyright Notice**

The Motorola products described in this manual may include copyrighted Motorola and third-party software stored in semiconductor memories or other media. Laws in the United States and other countries preserve for Motorola and third-party software providers certain exclusive rights for copyrighted software, such as the exclusive rights to distribute or reproduce the copyrighted software. Accordingly, any copyrighted software contained in the Motorola products may not be modified, reverse-engineered, distributed, or reproduced in any manner to the extent allowed by law. Furthermore, the purchase of the Motorola products shall

not be deemed to grant either directly or by implication, estoppel, or otherwise, any license under the copyrights, patents, or patent applications of Motorola or any third-party software provider, except for the normal, non-exclusive, royalty-free license to use that arises by operation of law in the sale of a product.

Manual Number: 68XXXXX120-0

DRAFT

# contents

---

<b>menu map</b> . . . . .	<b>6</b>	codes & passwords . . . . .	40
<b>Safety Information</b> . . . . .	<b>8</b>	lock & unlock phone . . . . .	40
<b>EU Conformance</b> . . . . .	<b>15</b>	<b>customize</b> . . . . .	<b>41</b>
<b>Recycling Information</b> . . . . .	<b>16</b>	ring style . . . . .	41
<b>essentials</b> . . . . .	<b>17</b>	ring & event lights . . . . .	42
about this guide . . . . .	17	time & date . . . . .	42
SIM card . . . . .	17	wallpaper . . . . .	43
battery . . . . .	18	screen saver . . . . .	43
turn it on & off . . . . .	21	display appearance . . . . .	44
make a call . . . . .	21	answer options . . . . .	45
answer a call . . . . .	21	<b>calls</b> . . . . .	<b>46</b>
store a phone number . . . . .	21	turn off a call alert . . . . .	46
call a stored phone . . . . .	22	recent calls . . . . .	46
number . . . . .	22	redial . . . . .	47
your phone number . . . . .	22	return a call . . . . .	48
<b>main attractions</b> . . . . .	<b>24</b>	caller ID . . . . .	48
play videos . . . . .	24	emergency calls . . . . .	48
multimedia messages . . . . .	25	voicemail . . . . .	49
cable connections . . . . .	27	push to talk (PTT) . . . . .	50
<b>basics</b> . . . . .	<b>28</b>	<b>other features</b> . . . . .	<b>55</b>
display . . . . .	28	advanced calling . . . . .	55
menus . . . . .	32	phonebook . . . . .	60
text entry . . . . .	34	messages . . . . .	64
volume . . . . .	38	instant messaging . . . . .	66
navigation key . . . . .	39	chat . . . . .	68
external display . . . . .	39	personalizing . . . . .	68
handsfree speaker . . . . .	39	call times & costs . . . . .	71

handsfree . . . . .	71
data & fax calls . . . . .	73
network. . . . .	74
personal organizer. . . . .	74
security . . . . .	75
fun & games . . . . .	76
<b>service and repairs . . . . .</b>	<b>78</b>
<b>SAR Data . . . . .</b>	<b>79</b>
<b>Warranty . . . . .</b>	<b>81</b>
<b>WHO Information . . . . .</b>	<b>87</b>
<b>index . . . . .</b>	<b>88</b>

# menu map

## main menu



### Phonebook



### Recent Calls

- Received Calls
- Dialed Calls
- Notepad
- Call Times \*
- Call Cost \*
- Data Times \*
- Data Volumes \*



### Messages

- Create Message
- Message Inbox
- Voicemail
- Browser Msgs
- Info Services \*
- Quick Notes
- Outbox
- Drafts
- MMS Templates



### Tools

- SIM Tool Kit Apps \*
- Voice Message
- Calculator
- Datebook
- Shortcuts
- Alarm Clock
- Chat \*
- Dialing Services
  - Fixed Dial \*
  - Quick Dial
  - Voice Dial



### Games & Apps



### Web Access \*

- Browser
- Web Shortcuts
- Stored Pages
- History
- Go To URL
- Browser Setup
- Web Sessions \*



### Multimedia

- Pictures
- Sounds
- Videos \*



### IM \*

- Log In
- Offline Convs.
- IM Account
- Offline Settings
- Help



### Settings

- (see next page)

\* optional features

This is the standard main menu layout. Your phone's menu may be a little different.



## settings menu



### Personalize

- Home Screen
- Main Menu
- Color Style
- Greeting
- Wallpaper
- Screen Saver



### Ring Styles

- Style
- style Detail
- Ring Lights
- Event Lights



### Sync \*



### Call Forward \*

- Voice Calls
- Fax Calls
- Data Calls
- Cancel All
- Forward Status



### In-Call Setup

- In-Call Timer
- Call Cost Setup \*
- My Caller ID
- Talk and Fax
- Answer Options
- Call Waiting



### Initial Setup

- Time and Date
- 1-Touch Dial
- Display Timeout
- Backlight
- TTY Setup \*
- Scroll
- Language
- Contrast
- DTMF
- Master Reset
- Master Clear



### Phone Status

- My Tel. Numbers
- Credit Info/Available \*
- Active Line \*
- Battery Meter
- Other Information



### Headset

- Auto Answer
- Voice Dial



### Car Settings

- Auto Answer
- Auto Handsfree
- Power-Off Delay
- Charger Time



### Network

- New Network
- Network Setup
- Available Networks
- My Network List \*
- Service Tone \*
- Network Jingle \*
- Call Drop Tone



### Security

- Phone Lock
- Lock PTT Key \*
- Lock Application
- Fixed Dial \*
- Restrict Calls \*
- Call Barring \*
- SIM PIN
- New Passwords
- Certificate Mgmt \*



### PTT Settings \*

- PTT Service



### Java Settings

- Java System
- Delete All Apps
- App Vibration
- App Volume
- App Priority \*
- App Backlight
- Set Standby App \*
- DNS IP \*

\* optional features

# Safety and General Information

---

IMPORTANT INFORMATION ON SAFE AND EFFICIENT OPERATION. READ THIS INFORMATION BEFORE USING YOUR PHONE.<sup>1</sup>

## Exposure To Radio Frequency (RF) Energy

Your phone contains a transmitter and a receiver. When it is ON, it receives and transmits RF energy. When you communicate with your phone, the system handling your call controls the power level at which your phone transmits.

Your Motorola phone is designed to comply with local regulatory requirements in your country concerning exposure of human beings to RF energy.

## Operational Precautions

To assure optimal phone performance and make sure human exposure to RF energy is within the guidelines set forth in the relevant standards, always adhere to the following instructions.

### External Antenna Care

If your phone has an external antenna, use only the supplied or Motorola-approved replacement antenna. Unauthorized antennas, modifications, or attachments could damage the phone and/or may result in non-compliance with local regulatory requirements in your country.

Do NOT hold the external antenna when the phone is IN USE. Holding the external antenna affects call quality and may cause the phone to operate at a higher power level than needed.

### Phone Operation

When placing or receiving a phone call, hold your phone as you would a wireline phone.

## Body-Worn Operation: Voice Communication

To maintain compliance with RF energy exposure guidelines, if you wear a phone on your body when transmitting voice communications, always place the phone in a Motorola-supplied or approved clip, holder, holster, case, or body harness for this phone, if available. Use of accessories not approved by Motorola may exceed RF energy exposure guidelines.

If you do not use one of the body-worn accessories approved or supplied by Motorola, and are not using the phone held in the normal use position, ensure the phone and its antenna are at least 2.5 centimeters (1 inch) from your body when transmitting.

## Data Operation

When using any data feature of the phone, with or without an accessory cable, position the phone and its antenna at least 2.5 centimeters (1 inch) from your body.

## Approved Accessories

Use of accessories not approved by Motorola, including but not limited to batteries, antennas, and convertible covers, may cause your phone to exceed RF energy exposure guidelines. For a list of approved Motorola accessories, visit our website at [www.motorola.com](http://www.motorola.com).

## RF Energy Interference/Compatibility

**Note:** Nearly every electronic device is susceptible to RF energy interference from external sources if inadequately shielded, designed, or otherwise configured for RF energy compatibility. In some circumstances your phone may cause interference.

**Note:** This device complies with Part 15 of the FCC Rules. Operation is subject to the following two conditions: (1) this device may not cause harmful interference, and (2) this device must accept any interference received, including interference that may cause undesired operation.

## Facilities

Turn off your phone in any facility where posted notices instruct you to do so. These facilities may include hospitals or health care facilities that may be using equipment that is sensitive to external RF energy.

## Aircraft

Turn off your wireless device whenever instructed to do so by airline staff. If your device offers a flight mode or similar feature, consult airline staff about use in flight. If your device offers a feature that automatically turns on the phone, then turn off this feature before boarding an airplane or entering an area where the use of wireless devices is restricted.

## Medical Devices

### Pacemakers

Pacemaker manufacturers recommend that a minimum separation of 15 centimeters (6 inches) be maintained between a handheld wireless phone and a pacemaker.

Persons with pacemakers should:

- ALWAYS keep the phone more than 15 centimeters (6 inches) from your pacemaker when the phone is turned ON.
- NOT carry the phone in the breast pocket.
- Use the ear opposite the pacemaker to minimize the potential for interference.
- Turn OFF the phone immediately if you have any reason to suspect that interference is taking place.

### Hearing Aids

Some digital wireless phones may interfere with some hearing aids. In the event of such interference, you may want to consult your hearing aid manufacturer to discuss alternatives.

## Other Medical Devices

If you use any other personal medical device, consult the manufacturer of your device to determine if it is adequately shielded from RF energy. Your physician may be able to assist you in obtaining this information.

## Use While Driving

Check the laws and regulations on the use of phones in the area where you drive. Always obey them.

When using your phone while driving, please:

- Give full attention to driving and to the road. Using a phone may be distracting in certain circumstances. Discontinue a call if you can't concentrate on driving.
- Use handsfree operation, if available.
- Pull off the road and park before making or answering a call if driving conditions so require.

Responsible driving best practices can be found in the "Wireless Phone Safety Tips" at the end of this guide and/or at the Motorola website: [www.motorola.com/callsmart](http://www.motorola.com/callsmart).

## Operational Warnings

### For Vehicles With an Air Bag

Do not place a phone in the area over an air bag or in the air bag deployment area. Air bags inflate with great force. If a phone is placed in the air bag deployment area and the air bag inflates, the phone may be propelled with great force and cause serious injury to occupants of the vehicle.

### Gas or Petrol Stations

Obey all posted signs with respect to the use of radio equipment in gas or petrol stations. Turn off your wireless device if instructed by authorized staff.

## Potentially Explosive Atmospheres

Turn off your phone prior to entering any area with a potentially explosive atmosphere. Do not remove, install, or charge batteries in such areas. Sparks in a potentially explosive atmosphere can cause an explosion or fire resulting in bodily injury or even death.

**Note:** The areas with potentially explosive atmospheres referred to above include fueling areas such as below decks on boats, fuel or chemical transfer or storage facilities, areas where the air contains chemicals or particles, such as grain, dust, or metal powders. Areas with potentially explosive atmospheres are often but not always posted.

## Blasting Caps and Areas

To avoid possible interference with blasting operations, turn OFF your phone when you are near electrical blasting caps, in a blasting area, or in areas posted "Turn off electronic devices." Obey all signs and instructions.

## Damaged Products





If your phone or battery has been submerged in water, punctured, or subjected to a severe fall, do not use it until you take it to a Motorola Authorized Service Center to determine if it has been damaged. Do not attempt to dry it with an external heat source, such as a microwave oven.

## Batteries and Chargers

Batteries can cause property damage and/or bodily injury such as burns if a conductive material such as jewelry, keys, or beaded chains touch exposed terminals. The conductive material may complete an electrical circuit (short circuit) and become hot. Take care when handling a charged battery, particularly when placing it inside a pocket, purse, or other container with metal objects. **Use only Motorola Original™ batteries and chargers.**

**Caution:** To avoid risk of personal injury, do not dispose of your battery in a fire.

Your battery, charger, or phone may contain symbols, defined as follows:

<b>Symbol</b>	<b>Definition</b>
	Important safety information will follow.
	Your battery or phone should not be disposed of in a fire.
	Your battery or phone may require recycling in accordance with local laws. Contact your local regulatory authorities for more information.
	Your battery or phone should not be thrown in the trash.
	Your phone contains an internal lithium ion battery.

## Choking Hazards

Your phone or its accessories may include detachable parts, which may present a choking hazard to small children. Keep your phone and its accessories away from small children.

## Seizures/Blackouts

Some people may be susceptible to epileptic seizures or blackouts when exposed to flashing lights, such as when watching television or playing video games. These seizures or blackouts may occur even if a person never had a previous seizure or blackout.

If you have experienced seizures or blackouts, or if you have a family history of such occurrences, please consult with your doctor before playing video games on your phone or enabling a flashing-lights feature on your phone. (The flashing-light feature is not available on all products.)

Parents should monitor their children's use of video game or other features that incorporate flashing lights on the phones. All persons should discontinue use and consult a doctor if any of the following symptoms

occur: convulsion, eye or muscle twitching, loss of awareness, involuntary movements, or disorientation.

To limit the likelihood of such symptoms, please take the following safety precautions:

- Do not play or use a flashing-lights feature if you are tired or need sleep.
- Take a minimum of a 15-minute break hourly.
- Play in a room in which all lights are on.
- Play at the farthest distance possible from the screen.

## Repetitive Motion Injuries

When you repetitively perform actions such as pressing keys or entering finger-written characters, you may experience occasional discomfort in your hands, arms, shoulders, neck, or other parts of your body. Follow these instructions to avoid problems such as tendonitis, carpal tunnel syndrome, or other musculoskeletal disorders:

- Take a minimum 15-minute break every hour of game playing.
  - If your hands, wrists, or arms become tired or sore while playing, stop and rest for several hours before playing again.
  - If you continue to have sore hands, wrists, or arms during or after play, stop playing and see a doctor.
1. The information provided in this document supersedes the general safety information in user's guides published prior to January 28, 2005.



# European Union Directives Conformance Statement

---

**CE** Hereby, Motorola declares that this product is in compliance with

- The essential requirements and other relevant provisions of Directive 1999/5/EC
- All other relevant EU Directives

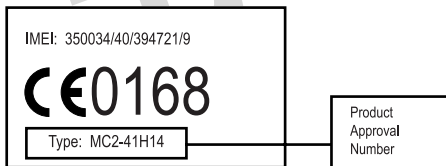

The above gives an example of a typical Product Approval Number.

You can view your product's Declaration of Conformity (DoC) to Directive 1999/5/EC (to R&TTE Directive) at [www.motorola.com/rtte](http://www.motorola.com/rtte). To find your DoC, enter the product Approval Number from your product's label in the "Search" bar on the web site.

# Caring for the Environment by Recycling

---



When you see this symbol on a Motorola product, do not dispose the product with household waste.

## Recycling Mobile Phones and Accessories

---

Do not dispose of mobile phones or electrical accessories, such as chargers or headsets, with your household waste. In some countries or regions, collection systems are set up to handle electrical and electronic waste items. Contact your regional authorities for more details. If collection systems aren't available, return unwanted mobile phones or electrical accessories to any Motorola Approved Service Centre in your region.



# essentials



---

## about this guide

This guide shows how to locate a menu feature as follows:

**Find it:** Press  >  **Recent Calls** > **Dialed Calls**

This example shows that, from the home screen, you press the *menu key*  to open the menu. Scroll to and select  **Recent Calls**, then scroll to and select **Dialed Calls**.

Press the *navigation key*  to scroll to a menu feature. Press the *center key*  to select the highlighted menu feature.

symbols	
	This means a feature is network/subscription dependent and may not be available in all areas. Contact your service provider for more information.
	This means a feature requires an optional accessory.

## SIM card

**Caution:** Don't bend or scratch your SIM card. Keep it away from static electricity, water, and dirt.

Your *Subscriber Identity Module* (SIM) card contains personal information like your phone number and phonebook entries.

1

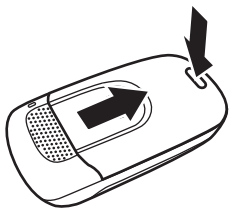

2

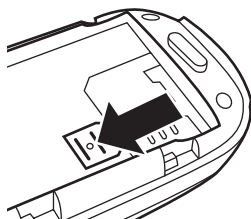

3

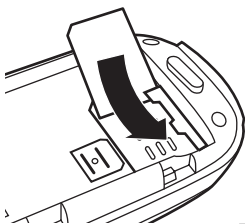

4

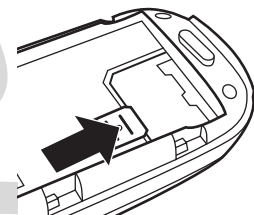

battery

battery installation

1

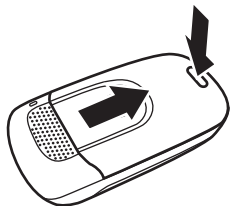

2

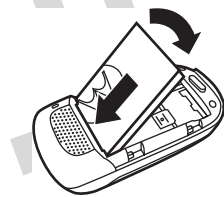

3

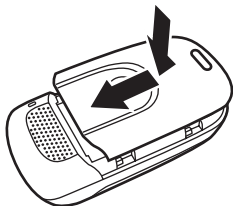

## battery charging

New batteries are not fully charged. Plug the battery charger into your phone and an electrical outlet. Your phone might take several seconds to start charging the battery. Your display shows **Charge Complete** when finished.

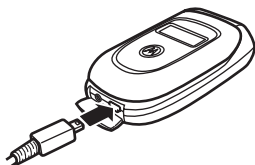

**Tip:** Relax, you can't overcharge your battery. It will perform best after you fully charge and discharge it a few times.

Your phone has a light just below the external display that can pulse when you charge your battery. To turn this light on or off, see page 42.

You can charge your battery by connecting a cable from your phone's mini-USB port to a USB port on a computer. Both your phone and the computer must be turned on, and your computer must have the correct software drivers installed. Cables and software drivers are available in Motorola Original data kits, sold separately.



## battery tips

Battery life depends on the network, signal strength, temperature, features, and accessories you use.

- Always use Motorola Original batteries and chargers. The warranty does not cover damage caused by non-Motorola batteries and/or chargers.
- New batteries or batteries stored for a long time may take more time to charge.
- When charging your battery, keep it near room temperature.
- When storing your battery, keep it uncharged in a cool, dark, dry place, such as a refrigerator.
- Never expose batteries to temperatures below  $-10^{\circ}\text{C}$  ( $14^{\circ}\text{F}$ ) or above  $45^{\circ}\text{C}$  ( $113^{\circ}\text{F}$ ). Always take your phone with you when you leave your vehicle.
- It is normal for batteries to gradually wear down and require longer charging times. If you notice a change in your battery life, it is probably time to purchase a new battery.



Contact your local recycling center for proper battery disposal.

**Warning:** Never dispose of batteries in a fire because they may explode.

Before using your phone, read the battery safety information in the “Safety and General Information” section included in this guide.

## turn it on & off

**Caution:** Some phones ask for your SIM card PIN code when you turn them on. If you enter an incorrect PIN code 3 times in a row, your SIM card is disabled and your display shows **SIM Blocked**. Contact your service provider.

To turn on your phone, press and hold  for a few seconds or until the display turns on. If prompted, enter your 6-digit SIM card PIN code and/or 4-digit unlock code.



To turn off your phone, press and hold  for 2 seconds.

## make a call

Enter a phone number and press  to make a call.

To “hang up,” close the flip or press .

## answer a call

When your phone rings and/or vibrates, just open the flip or press  to answer.

To “hang up,” close the flip or press .

## store a phone number

You can store a phone number in your **Phonebook**:

- 1 Enter a phone number in the home screen.
- 2 Press the **Store** key.

- 3 Enter a name and other details for the phone number. To select a highlighted item, press the *center key* .



**Note:** You can store a phonebook entry on your phone or on your SIM card. In the entry, select **Store To** and choose **Phone** or **SIM**. Entries stored on the SIM card can only include name and number details.

- 4 Press the **Done** key to store the number.

To edit or delete a **Phonebook** entry, see page 60.

To store an email address, press  >  **Phonebook**, then press  > **New** > **Email Address**

## call a stored phone number



**Find it:**  >  **Phonebook**

- 1 Scroll to the phonebook entry.



**Shortcut:** In the phonebook, press keypad keys to enter the first letters of an entry name, then press the **Search** key to jump to the entry.

- 2 Press  to call the entry.

## your phone number

From the home screen, press   to see your number.

**Tip:** Want to see your phone number while you're on a call? Press  > **My Tel. Numbers**.

You can edit the name and phone number stored on your SIM card. From the home screen, press  ,





select an entry, and press the **Edit** key. If you don't know your phone number, contact your service provider.

DRAFT

# main attractions

---

You can do much more with your phone than make and receive calls!

## play videos

**Find it:** Press  >  **Multimedia** > **Videos** > *video name*



The video clip plays:

Press   
up to pause or  
play the video.

Press   
down to stop  
the video.

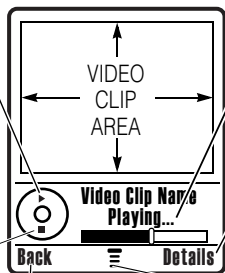

Status

View video  
details.

Return to previous  
screen.

Press  to  
open **Videos**  
**Menu**.

To download a video with the micro-browser, see page 76.  
You can also attach videos to multimedia messages.

# multimedia messages

To create a group mailing list, see page 63. For more message features, see page 64.

## send a multimedia message

A *Multimedia Messaging Service* (MMS) message contains pages with text and media objects (including pictures, animations, or sounds). You can send the multimedia message to other MMS-capable phones, and to email addresses.



**Find it:** Press  > **Create Message** > **New Multimedia Msg**

- 1 Press keypad keys to enter text on the page (for details about text entry, see page 34).

To insert a **picture, sound, or other object** on the page, press  > **Insert**. Select the file type and the file.

To insert **another page** in the message, enter text or objects on the current page and press  > **Insert** > **New Page**. You can enter more text and objects on the new page.

- 2 When you finish the message, press the **Send To** key.
- 3 Choose one or more people for **Send To**:

To select a **phonebook entry**, scroll to the entry and press the *center key* . Repeat to add other phonebook entries.

To **enter** a new number or email address, scroll to **[New Number]** or **[New Email Address]** and press the *center key* .

4 To **send** the message, press the **Send** key.

Before you send a message, press  to choose **Save to Drafts**, **Abort Message**, or open **Message Options** (such as message **Subject** or **CC** addresses).

## receive a multimedia message

When you receive a multimedia message or letter, your phone plays an alert and the display shows **New Message** with a message indicator such as .



Press the **Read** key to open the message.

If a multimedia message contains media objects:

- Photos, pictures, and animations show as you read the message.
- A sound file plays when its slide shows. Use the volume keys to adjust the sound volume.

**Note:** In a multimedia letter, you may have to scroll to an indicator in the text to play a sound file.

- Attached files are added to the end of the message. To open an attachment, scroll to the file indicator/filename and press the **View** key (image), **Play** key (sound), or **Open** key (phonebook vCard, datebook vCalendar entry, or unknown file type).

## cable connections

 Your phone has a mini-USB port so you can connect it to a computer to transfer data.

You can use data cables and supporting software on your computer to:

- Synchronize phonebook and datebook information between your phone and a computer or hand-held device.
- Use your phone as a modem to connect to the Internet.
- Use your phone to send and receive data calls from your computer or handheld device.

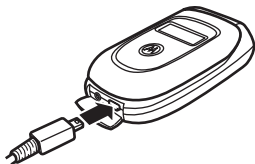

**Note:** Motorola Original USB data cables and supporting software are sold separately. Check your computer or hand-held device to determine the type of cable you need. To **transfer data** between your phone and computer, you must install the software included with the Motorola Original data kit. See the data kit user's guide for more information. To make **data and fax calls** through a connected computer, see page 73.



# basics

---



See page 1 for a basic phone diagram.

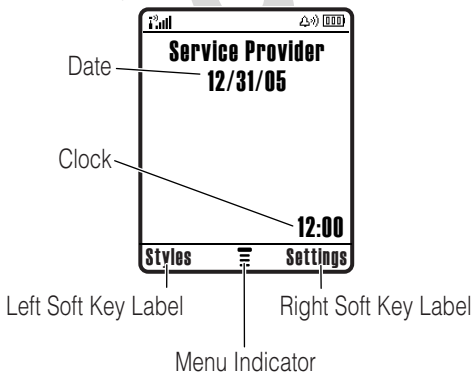

## display

The *home screen* shows when you turn on the phone. To dial a number from the home screen, press number keys and .

**Note:** Your home screen may look different from the one below, depending on your service provider.



The *Menu Indicator*  shows that you can press  to open the menu. *Soft Key Labels* show the current soft key functions. For soft key locations, see page 1.

Your home screen might show headlines from your service provider at the bottom. To change this headline view, press  >  **Settings** > **Personalize** > **Home Screen** > **Headlines**. 

Status indicators can show at the top of the home screen:

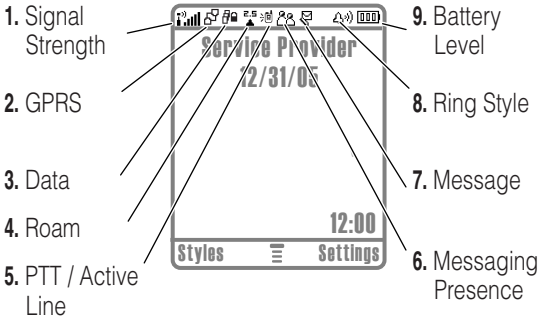

**1 Signal Strength Indicator** – Vertical bars show the strength of the network connection. You can't make or receive calls when or shows.

**2 GPRS Indicator** – Shows when your phone is using a high-speed *General Packet Radio Service* (GPRS) network connection. Indicators show PDP context active or packet data available .

**3 Data Indicator** – Shows connection status.

= secure packet data transfer

= unsecure packet data transfer

= secure application connection

= unsecure application connection

= secure *Circuit Switch Data* (CSD) call

= unsecure CSD call

**4 Roam Indicator** – Shows when your phone is seeking or using a network outside your home network. Indicators can include:



= 2G home

= 2G roam

= 2.5G home

= 2.5G roam

**5 PTT / Active Line Indicator** – Shows when you can make and receive PTT calls ( or or both PTT calls and Instant Messages (). This also shows to indicate an active phone call, or to indicate when call forwarding is on. Indicators for dual-line-enabled SIM cards can include:



= line 1 active

= line 1 active, call forward on

= line 2 active

= line 2 active, call forward on

**6 Messaging Presence Indicator** – Shows when Instant Messaging (IM) is active. Indicators can include:



= IM active

= available for IM

= busy

= invisible to IM

= available for phone calls





= offline

When a Java™ application is active, can show here.



- 7 Message Indicator** – Shows when you receive a new message. Indicators can include:



-  = text message                       = voicemail message  
 = voicemail & text message  
 = IM message                       = active chat session

- 8 Ring Style Indicator** – Shows the ring style setting.

-  = loud ring                       = vibrate then ring  
 = soft ring                       = silent  
 = vibrate







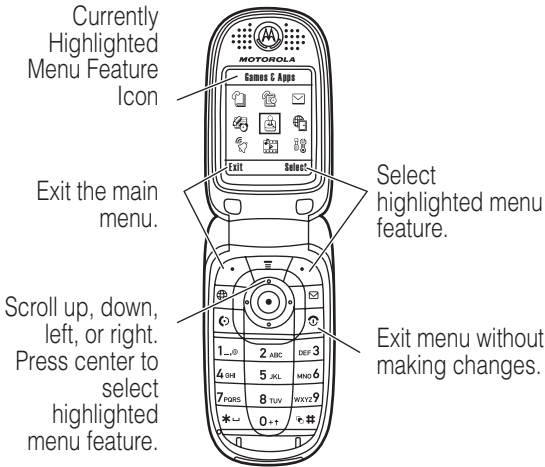



- 9 Battery Level Indicator** – Vertical bars show the battery charge level. Recharge the battery when your phone shows **Low Battery**.

# menus

From the home screen, press  to enter the main menu.



The following menu icons may be available, depending on your service provider and service subscription options.

menu features	
 Phonebook	 Web Access
 Recent Calls	 Multimedia
 Messages	 IM
 Tools	 Settings
 Games & Apps	 Chat

**Note:** Your *Instant Messaging (IM)* menu icon may be different from the icon in the table, depending on your service provider.

Some features require you to select an option from a list:

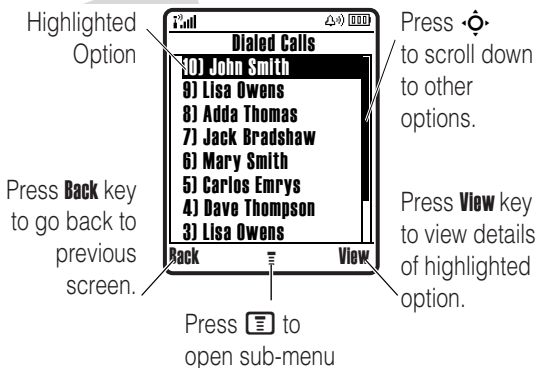

- Scroll up or down to scroll to the option you want.
- In a numbered list, press a number key to highlight an option.
- In an alphabetized list, press a key repeatedly to cycle through its letters and highlight the closest matching list option.
- When an option has a list of possible settings, scroll left or right to select the setting.
- When an option has a list of possible numeric values, press a number key to set the value.

# text entry

Some features let you enter text.

For indicator descriptions, see following section.

*Flashing cursor* indicates insertion point.







Press  to open sub-menu.

After you enter text, press the **Send To** key to enter recipients.

Press the **Cancel** key to exit without making changes.

Press  in a text entry view to select an entry mode:

entry modes	
 or <b>1</b>	Your <b>Primary</b> text entry mode can be set to any iTAP™  or tap <b>1</b> mode.
 or <b>2</b>	Your <b>Secondary</b> text entry mode can be set to any iTAP  or tap <b>2</b> mode, or set to <b>None</b> if you don't want a secondary entry mode.
12	<b>Numeric</b> mode enters numbers only.
@	<b>Symbol</b> mode enters symbols only.

To set your primary and secondary text entry modes, press **[☰]** > **Entry Setup** in a text entry view and select **Primary Setup** or **Secondary Setup**.

**Tip:** WANT TO SHOUT YOUR MESSAGE? Press **[0]** in a text entry view to change text case to all capital letters (**AB**), next letter capital (**Ab**), or no capitals (**ab**).

## iTAP™ mode

Press **[#]** in a text entry view to switch to iTAP mode. If you don't see **[ab]** or **[Ab]**, press **[☰]** > **Entry Setup** to set iTAP mode as your primary or secondary text entry mode.

iTAP mode lets you enter words using one keypress per letter. The iTAP software combines your keypresses into common words, and predicts each word as you enter it.

For example, if you press **[7]** **[7]** **[6]** **[4]**, your display shows:

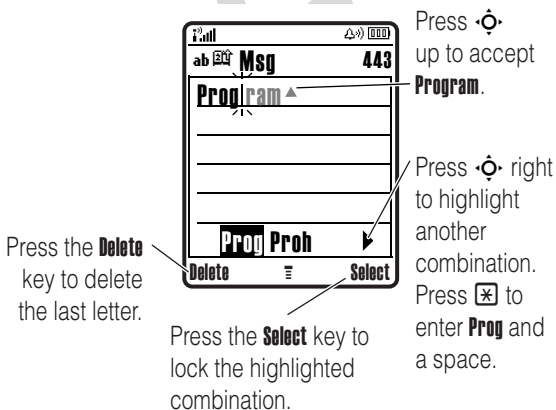

- If you want a different word (such as **Progress**), continue pressing keypad keys to enter the remaining letters.
- To enter numbers quickly, press and hold a number key to temporarily switch to numeric mode. Press the number keys to enter the numbers you want. Enter a space to change back to iTAP mode.
- Press **1** to enter punctuation or other characters.

## tap mode

Press **#** in a text entry view to switch to tap mode. If you don't see **Ab 1** or **Ab 2**, press **☰** > **Entry Setup** to set tap mode as your primary or secondary text entry mode.

To enter text in tap mode, press a keypad key repeatedly to cycle through the letters and number on the key. Repeat this step to enter each letter.

For example, if you press **8** one time, your display shows:

Character displays at insertion point.

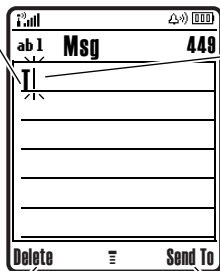

After 2 seconds, character is accepted and cursor moves to next position.

Press the **Delete** key to delete character to left of insertion point.

After you enter text, press the **Send To** key to enter recipients.

When you enter three or more characters in a row, your phone may guess the rest of the word. For example, if you enter **prog** your display might show:

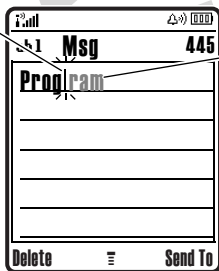

Character displays at insertion point.



Press **⬆** right to accept **Program**, or press **✖** to reject it and enter a space after **Prog**.

- The first character of every sentence is capitalized. If necessary, press **⬇** down to change the character to



lowercase before the cursor moves to the next position.

- Press  to move the flashing cursor to enter or edit message text.
- If you don't want to save your text or text edits, press  to exit without saving.
- *Tap extended* mode cycles through additional special characters and symbols as you repeatedly press a keypad key.

## numeric mode

Press  in a text entry view until you see 12. Press the number keys to enter the numbers you want.

## symbol mode

Press  in a text entry view until you see @. Press a keypad key to show its symbols at the bottom of the display. Scroll to the symbol you want, then press the *center key* .

## volume

Press the volume keys to:

- turn off an incoming call alert
- change the earpiece volume during calls
- change the ringer volume from the home screen

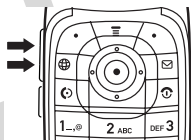





**Tip:** Sometimes silence really is golden. That's why you can quickly set your ringer to **Vibrate** or **Silent** by holding the down volume key in the home screen.

To change your ringer volume when your phone is closed, see page 39.

## navigation key

Press the *navigation key*  up, down, left, or right to scroll to items in the display. When you scroll to something, press the *center key*  to select it.

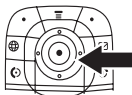

## external display

When your phone is closed, the external display shows the time and indicates phone status, incoming calls, and other events. For a list of phone status indicators, see page 29.

## handsfree speaker

You can use your phone's handsfree speaker to make calls without holding the phone to your ear.

During a call, press the **Speaker** key to turn the handsfree speaker on. Your display shows **Spkrphone On** until you turn it off or end the call.

**Note:** The handsfree speaker won't work when your phone is connected to a handsfree car kit or headset.

## codes & passwords

Your phone's 4-digit **unlock code** is originally set to **1234**. The 6-digit **security code** is originally set to **000000**. If your service provider didn't change these codes, you should change them:

**Find it:** Press  >  **Settings** > **Security** > **New Passwords**

You can also change your **SIM PIN** password.



**If you forget your unlock code:** At the **Enter Unlock Code** prompt, try entering 1234 or the last four digits of your phone number. If that doesn't work, press  and enter your 6-digit security code instead.

**If you forget other codes:** If you forget your security code, SIM PIN code, or PIN2 code, contact your service provider.

## lock & unlock phone

You can lock your phone to keep others from using it. To lock or unlock your phone, you need the 4-digit unlock code.

To **manually lock** your phone: Press  >  **Settings** > **Security** > **Phone Lock** > **Lock Now**.

To **automatically lock** your phone whenever you turn it off: Press  >  **Settings** > **Security** > **Phone Lock** > **Automatic Lock** > **On**.

**Note:** You can make emergency calls on a locked phone (see page 48). A locked phone still rings or vibrates for incoming calls or messages, **but you need to unlock it to answer**.

# customize

---

## ring style

Each ring style profile uses a different set of sounds or vibrations for incoming calls and other events. Here are the profiles you can choose:

 Loud

 Vibrate

 Silent

 Soft

 Vibe then Ring

The ring style profile's indicator shows at the top of your home screen. To choose your profile:

**Find it:** Press  >  Settings > Ring Styles > Style: *style name*

**Shortcut:** In the **home screen**, press the volume keys up or down to quickly change your ring style profile. With your **phone closed**, press a volume key to see your ring style profile, press the smart key to change it, then press a volume key to store the change.

## change alerts in a ring style

You can change the alerts for incoming calls and other events. Your changes are saved in the current ring style profile.

**Find it:** Press  >  Settings > Ring Styles > *style Detail*

**Note:** *Style* represents the current ring style. You can't set an alert for the **Silent** ring style setting.

- 1 Scroll to **Calls** (or **Line 1** or **Line 2** for dual-line phones), then press the **Change** key to change it.
- 2 Scroll to the alert you want, then press the *center key* .
- 3 Press the **Back** key to save the alert setting.

**Tip:** If you want a ring that sets you apart, you can use an MP3 sound file. To download files, see page 76.

## ring & event lights

Your phone has a light just below the external display that can pulse for incoming calls or messages, or while you charge your battery.



To set the light for your **incoming calls**, press  >  **Settings** > **Ring Styles** > **Ring Lights**.

You can also turn the ring light on or off for calls from phonebook entries in a **Category** (see page 62).

To set the light for your **incoming messages and battery charging**, press  >  **Settings** > **Ring Styles** > **Event Lights**.

## time & date



Your phone needs the time and date for the datebook.

To **synchronize** the time and date with the network: Press  >  **Settings** > **Initial Setup** > **Time and Date** > **Autoupdate** > **On**.



To **manually** set the time and date, turn off **Autoupdate**, then: Press  >  **Settings** > **Initial Setup** > **Time and Date** > *time* or *date*.

To choose an **analog or digital** clock for your home screen, press  >  **Settings** > **Personalize** > **Home Screen** > **Display** > **Clock**.

**Note:** If your home screen shows headlines from your service provider, it uses a digital clock. To choose an analog clock, you must turn off the headlines. Press  >  **Settings** > **Personalize** > **Home Screen** > **Headlines** > **Off**.



## wallpaper

Set a photo, picture, or animation as a wallpaper (background) image in your home screen.

**Find it:** Press  >  **Settings** > **Personalize** > **Wallpaper**

options	
<b>Picture</b>	Press  up or down to select a picture, or select <b>None</b> for no wallpaper.
<b>Layout</b>	Select <b>Center</b> to center the image in the display, <b>Tile</b> to repeat the image across the display, or <b>Fit-to-screen</b> to stretch the image across the display.

## screen saver



Set a photo, picture, or animation as a screen saver. The screen saver shows when the flip is open and no activity is detected for a specified time.

**Tip:** This feature helps save your screen, but not your battery. To extend battery life, turn off the screen saver.

**Find it:** Press  >  **Settings** > **Personalize** > **Screen Saver**

options	
<b>Picture</b>	Press  up or down to select a picture or animation, or select <b>None</b> for no screen saver.
<b>Delay</b>	Select the length of inactivity before the screen saver shows.

## display appearance



To choose the **colors** that your phone uses for indicators, highlights, and soft key labels: Press  >  **Settings** > **Personalize** > **Color Style**.

To save battery life, your keypad **backlight** turns off when you're not using your phone. The backlight turns back on when you open the flip or press any key. To set how long your phone waits before the backlight turns off:

Press  >  **Settings** > **Initial Setup** > **Backlight**.

**Note:** To turn the backlight on or off for Java™ applications, press  >  **Settings** > **Java Settings** > **App Backlight**.

To save battery life, the **display** can turn off when you're not using your phone. The display turns back on when you open the flip or press any key. To set how long your phone waits before the display turns off:

Press  >  **Settings** > **Initial Setup** > **Display Timeout**.

# answer options

You can use different ways to answer an incoming call. To turn on or turn off an answer option:

**Find it:** Press  >  **Settings** > **In-Call Setup** > **Answer Options**

<b>options</b>	
<b>Multi-Key</b>	Answer by pressing any key.
<b>Open to Answer</b>	Answer by opening the flip.

# calls

---

To make and answer calls, see page 21.

## turn off a call alert

You can press the volume keys to turn off a call alert before answering the call.



## recent calls

Your phone keeps lists of incoming and outgoing calls, even for calls that didn't connect. The most recent calls are listed first. The oldest calls are deleted as new calls are added.

**Shortcut:** Press  from the home screen to see a list of recent calls.

**Find it:** Press  >  **Recent Calls** > **Received Calls** or **Dialed Calls**



Scroll to a call. A ✓ next to a call means the call connected.

- To call the number, press .
- To see call details (like time and date), press the *center key* .
- To see the **Last Calls Menu**, press . This menu can include:



options	
<b>Store</b>	Create a phonebook entry with the number in the <b>No.</b> field. <b>Store</b> does not appear if the number is already stored.
<b>Delete</b>	Delete the entry.
<b>Delete All</b>	Delete all entries in the list.
<b>Hide ID/Show ID</b>	Hide or show your caller ID for the next call.
<b>Send Message</b>	Open a new text message with the number in the <b>To</b> field.
<b>Add Digits</b>	Add digits after the number.
<b>Attach Number</b>	Attach a number from the phonebook or recent calls lists.
<b>Send Tones</b>	Send the number to the network as DTMF tones.  This option shows only during a call.
<b>Talk then Fax</b>	Talk and then send a fax in the same call (see page 73). 

## redial

- 1 Press  from the home screen to see a list of recent calls.
- 2 Scroll to the entry you want to call, then press .

If you hear a **busy signal** and you see **Call Failed, Number Busy**, you can press  or the **Retry** key to redial the number. When the call goes through, your phone



rings or vibrates one time, shows **Redial Successful**, and connects the call.

## return a call

Your phone keeps a record of your unanswered calls, and shows **X Missed Calls**, where **X** is the number of missed calls.

- 1 Press the **View** key to see the received calls list.
- 2 Scroll to the call you want to return, then press .

## caller ID

*Calling line identification* (caller ID) shows the phone number for an incoming call in your external and internal displays.



Your phone shows the caller's name and picture when they're stored in your phonebook, or **Incoming Call** when caller ID information isn't available.

You can set your phone to play a different ringer ID for an entry stored in your phonebook (see page 61).

To show or hide **your phone number** from the next person you call, enter the phone number and press

 > **Hide ID/Show ID**.

## emergency calls

Your service provider programs one or more emergency phone numbers, such as 911 or 112, that you can call under

any circumstances, even when your phone is locked or the SIM card is not inserted.

**Note:** Emergency numbers vary by country. Your phone's preprogrammed emergency number(s) may not work in all locations, and sometimes an emergency call cannot be placed due to network, environmental, or interference issues.

- 1 Press the keypad keys to dial the emergency number.
- 2 Press  to call the emergency number.

## voicemail

Your network stores the voicemail messages you receive. To listen to your messages, call your voicemail number. 

**Note:** Your service provider may include additional information about using this feature.

When you **receive** a voicemail message, your phone shows the voicemail message indicator  and **New Voicemail**. Press the **Call** key to listen to the message.

To **check** voicemail messages:

**Find it:** Press  > **Voicemail**

Your phone may prompt you to store your voicemail phone number. If you don't know your voicemail number, contact your service provider.

**Note:** You can't store a **p** (pause), **w** (wait), or **n** (number) character in this number. If you want to store a voicemail

number with these characters, create a phonebook entry for it. Then, you can use the entry to call your voicemail.

## push to talk (PTT)

*Push to Talk* (PTT) lets you talk walkie-talkie style with other PTT subscribers. You can talk to one person or a group.



PTT and the other related features indicated are network and subscription dependent features, and are not available in all areas. PTT connectivity requires PTT-compatible phones.



**Note:** To lock your PTT key or turn PTT on or off, see page 53.

### make a PTT call

When  shows at the top of your home screen, you can make and receive PTT calls. To make a PTT call:

- 1 Enter a PTT subscriber's phone number in your home screen, or select a contact or group from a list:
  - **PTT Contacts** (press the PTT key to open the list)  
**Note:** If you change your **Open To** setting, your PTT key does not open the contacts list (see page 53).
  - **PTT Quick Group** (press the PTT key and  > **PTT Quick Group**)  
This lets you select more than one contact for the call.
  - **PTT Groups** (press the PTT key and  > **PTT Groups**)
- 2 Hold the PTT key and speak after you hear the tone. Release the PTT key to let others speak.

**To speak during a PTT call**, hold your PTT key and speak after the tone. Only one person can speak at a time.

**To end the call**, press . If nobody speaks for 20 seconds, the call ends.

**To send a PTT alert** instead of a standard PTT call, scroll to a PTT contact in **PTT Contacts** and press the **Alert** key. The contact's phone rings or vibrates, and the contact can speak first. If the contact does not respond, the call ends. You cannot send alerts to groups.

## answer a PTT call

**When you receive a PTT call**, you hear a tone or alert followed by conversation from the caller.

- **To speak** when the caller stops speaking, hold your PTT key and speak after the tone. Only one person can speak at a time.
- **To end the call**, press .

If you change your **My Answer Mode** setting, your phone does not automatically answer as described (see page 53).



**When you receive a PTT alert**, press the PTT key and speak after the tone. You can also press the **Ignore** key to cancel the call.

Your phone shows **Missed Call** if you miss a PTT alert. It does not show **Missed Call** when you miss a standard PTT call unless you set **My Answer Mode** to **Manual** (see page 53).

## PTT contacts and groups



You can store PTT **Contacts** to make one-to-one calls, or you can store PTT **Groups** to make group calls.





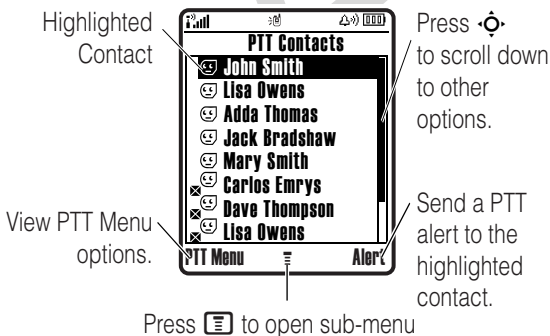

**To store a contact**, press **PTT key**, then  > **Add**. Enter the contact's **Name** and phone number (**No.**), then press the **Done** key. Your network stores the contact and your phone returns to the **PTT Contacts** list with the new contact shown.



**To create a group of contacts** that you can call at the same time, press **PTT key**, then  > **PTT Groups**, then  > **Create New Group**. Enter the group's **Name** and select the **Members**, then press the **Done** key. Your network stores the group and your phone returns to the **PTT Groups** list with the new group shown.

**To see PTT contacts**, press the PTT key. Scroll to a contact and press  to **View**, **Edit**, or **Delete** it.



**To see PTT groups**, press the PTT key and  > **PTT Groups**. Scroll to a group and press  to **View** or **Delete** it. You cannot edit a group, but you can delete it and create a new one with the members you want.

Icons in the PTT contact and group lists indicate if someone is online (, ) or offline (, ). They also tell you if a contact is blocked  (scroll to the contact and press  > **Block** or **Unblock**).



To set an **online alert**  to tell you when a contact comes online, scroll to the contact and press  > **Enable Online Alert**. You can turn online alert tones on or off in your **PTT Setup** menu (see page 53).

To refresh the contact or group list from your network, press  > **Refresh List**.

To see only your frequently used contacts or groups, press  > **Frequently Used**.

## PTT settings

To **turn PTT on or off** from your home screen, press  >  **Settings** > **PTT Settings** > **PTT Service** > **On/Off**.

To prevent accidental PTT calls, you can set your phone to **lock the PTT key** automatically when you haven't pressed it for a few minutes and your phone is closed. Press  >  **Settings** > **Security** > **Lock PTT Key** and select how long your phone should wait before it locks the key. To unlock the key, hold it for 2 seconds or open the phone. The PTT key unlocks when you receive a PTT call.

You can change your PTT menu and call preferences.

**Find it:** Press **PTT key**, then  > **PTT Setup** > **PTT Personalize**

<b>options</b>	
<b>Open To</b>	From the home screen, the PTT key can open the PTT menu ( <b>Main Menu</b> ), or your contacts list sorted by name ( <b>Top of List</b> ), or most recent call ( <b>Last Call</b> ).
<b>Sort by</b>	Sort your contacts and groups by <b>Name</b> , online <b>Status</b> , or call <b>Frequency</b> .
<b>My Answer Mode</b>	Set the mode for incoming PTT calls to <b>Manual</b> (press the PTT key to answer), <b>Auto-Accept</b> (standard mode that accepts all calls), or <b>Do Not Disturb</b> (accepts no calls).
<b>Tone Volume</b>	Set the volume for the tone you hear when it is your turn to speak.
<b>PTT Speaker</b>	Turn the speakerphone <b>On</b> or <b>Off</b> for PTT calls.
<b>Set Online Alert Tone</b>	<p>You can set an online alert to tell you when a contact or group comes online (scroll to the entry in your <b>PTT Contacts</b> or <b>PTT Groups</b> and press  &gt; <b>Enable Online Alert</b>).</p> <p>This setting tells your phone whether to play these alert tones (<b>On</b>) or not (<b>Off</b>).</p>



# other features

---

## advanced calling

### features



#### 1-touch dial

To call phonebook entries 1 through 9, press and hold the single-digit speed dial number for one second.

You can set 1-touch dial to call the entries in your phone's memory phonebook, your SIM card's phonebook, or your Fixed Dial list: Press 

 >  **Settings** > **Initial Setup** > **1-Touch Dial** > **Phone, SIM, or Fixed Dial**

To add a new phonebook entry, see page 21. To edit the **Speed No.** for a phonebook entry, press

 >  **Phonebook**, scroll to the entry, and press  > **Edit**.

## features



### speed dial

Speed dial a phonebook entry:



Enter the speed dial number, press , then press .

To add a phonebook entry, see page 21.

**Tip:** If you forget Aunt Mildred's speed dial number, press  >  **Phonebook**, scroll to her entry, and press the *center key* .

### attach a phone number

Dial an area code or prefix for a phonebook number, then:





 > **Attach Number**

### notepad

The last number you entered is stored in the *notepad*. You can use the notepad to “jot down” a number during a call for later use. To see the notepad:

Press  >  **Recent Calls** > **Notepad**

- To call the number, press .
- To create a phonebook entry with the number in the **No.** field, press the **Store** key.
- To open the **Dialing Menu** to attach a number or insert a special character, press .

## features

### international calls

If your phone service includes international dialing, press and hold  to insert your local international access code (indicated by +). Then, press the keypad keys to dial the country code and phone number.

### hold a call

Press  > **Hold** to put all active calls on hold.

### mute a call

Press  > **Mute** to put all active calls on mute.

### call waiting

When you're on a call, you'll hear an alert if you receive a second call. 



Press  to answer the new call.



















- To switch between calls, press the **Switch** key.
- To connect the two calls, press the **Link** key.
- To end the call on hold, press  > **End Call On Hold**.

To turn the call waiting feature on or off, press  >  **Settings** > **In-Call Setup** > **Call Waiting** > **On** or **Off**

### conference call

During a call:

Dial next number, press , press the **Link** key. 

features	
<b>transfer a call</b>	<p>During a call:</p> <p> &gt; <b>Transfer</b>, dial transfer number, press </p> 
<b>call forwarding</b>	<p>Set up or cancel call forwarding:</p> <p> &gt;  <b>Settings</b> &gt; <b>Call Forward</b></p> 
<b>restrict calls</b>	<p>Restrict outgoing or incoming calls:</p> <p> &gt;  <b>Settings</b> &gt; <b>Security</b> &gt; <b>Restrict Calls</b></p> 
<b>call barring</b>	<p>Restrict outgoing or incoming calls:</p> <p> &gt;  <b>Settings</b> &gt; <b>Security</b> &gt; <b>Call Barring</b></p> 
<b>TTY calls</b>	<p>Set up your phone for use with an optional TTY device:</p> <p> &gt;  <b>Settings</b> &gt; <b>Initial Setup</b> &gt; <b>TTY Setup</b></p> 
<b>change phone line</b>	<p>If you have a dual-line-enabled SIM card, you can change your line to make and receive calls from your other phone number.</p> <p> &gt;  <b>Settings</b> &gt; <b>Phone Status</b> &gt; <b>Active Line</b></p> <p>The active line indicator shows the active phone line (see page 30).</p> 



## features

### fixed dial

When you turn on fixed dialing, you can call only numbers stored in the fixed dial list.



Turn fixed dialing on or off:

 >  **Settings** > **Security** > **Fixed Dial**

Use the fixed dial list:

 >  **Tools** > **Dialing Services** > **Fixed Dial**

### quick dial

Dial preprogrammed phone numbers:



 >  **Tools** > **Dialing Services** > **Quick Dial**



### DTMF tones

Activate DTMF tones:

 >  **Settings** > **Initial Setup** > **DTMF**

To send DTMF tones during a call, just press number keys or scroll to a number in the phonebook or recent calls lists and press  > **Send Tones**.

# phonebook

features	
<b>edit or delete a phonebook entry</b>	<p>Edit a number stored in the phonebook:  &gt;  <b>Phonebook</b>, scroll to the phonebook entry, and press . You can select <b>Edit</b>, <b>Delete</b>, or other options.</p> <p><b>Shortcut:</b> In the phonebook, press keypad keys to enter the first letters of an entry name, then press the <b>Search</b> key to jump to the entry.</p>
<b>record voice name for a phonebook entry</b>	<p>When creating a phonebook entry, scroll to <b>Voice Name</b> and press the <b>Record</b> key. Press the <b>Record</b> key again and say the entry's name (within 2 seconds). When prompted, press the <b>Record</b> key and repeat the name.</p> <p><b>Note:</b> The <b>Voice Name</b> option isn't available in entries stored on the SIM card.</p>



## features

### voice dial a phonebook entry

Voice dial a number stored in the phonebook:



 >  **Tools** > **Dialing Services** > **Voice Dial**

When prompted, say the entry's voice name (within 2 seconds).

**Tip:** If you use **Voice Dial** a lot, you can create a shortcut to it. Scroll to **Voice Dial**, then press and hold . To use the shortcut, press  and the shortcut key number.

### set ringer ID for a phonebook entry

Assign a ring alert (ringer ID) to an entry:

 >  **Phonebook** > *entry*, then press  > **Edit** > **Ringer ID** > *ringer name*



**Note:** The **Ringer ID** option isn't available in entries stored on the SIM card.

Activate ringer IDs:













 >  **Settings** > **Ring Styles** > *style Detail* > **Ringer IDs**

### set picture ID for a phonebook entry

Assign a photo or picture to show when you receive a call from an entry:

 >  **Phonebook** > *entry*, then press  > **Edit** > **Picture** > *picture name*

**Note:** The **Picture** option isn't available in entries stored on the SIM card.

features	
<b>set picture ID view for phonebook</b>	<p>Show entries as a text list, or with picture caller ID photos:</p> <p> &gt;  <b>Phonebook</b>, then press</p> <p> &gt; <b>Setup</b> &gt; <b>View by</b> &gt; <i>view name</i></p>
<b>set category for a phonebook entry</b>	<p> &gt;  <b>Phonebook</b> &gt; <i>entry</i>, then press</p> <p> &gt; <b>Edit</b> &gt; <b>Category</b> &gt; <i>category name</i></p> <p><b>Note:</b> The <b>Category</b> option isn't available in entries stored on the SIM card.</p>
<b>set category view for phonebook</b>	<p> &gt;  <b>Phonebook</b>, then press</p> <p> &gt; <b>Categories</b> &gt; <i>category name</i></p> <p>You can show <b>All</b> entries, entries in a predefined category (<b>Business</b>, <b>Personal</b>, <b>General</b>, <b>VIPs</b>), or entries in a category you create.</p>
<b>set light ID for phonebook category</b>	<p>Turn on or off the ring light for calls from entries in a category:</p> <p> &gt;  <b>Phonebook</b>  &gt; <b>Categories</b>, scroll to the category, press  &gt; <b>Edit</b> &gt; <b>Light ID</b></p> <p>For more about ring lights, see page 42.</p> <p><b>Note:</b> The <b>Category</b> option isn't available in entries stored on the SIM card.</p>



## features

### set primary number or address for a phonbook entry

Set the primary number for an entry with multiple numbers:

 >  **Phonebook**, scroll to the entry, press  > **Set Primary** > *number or address*

**Note:** The **Set Primary** option isn't available in entries stored on the SIM card.

**Tip:** In **Primary** number view mode, you can still peek at other numbers stored for the same name. Scroll to the name and press  left or right to see the other numbers.







### create group mailing list

You can put several phonebook entries in a group mailing list, then send a message to the list. To create a list:

 >  **Phonebook**, then press  > **New** > **Mailing List**





You can select the list name as an address for multimedia messages.





















**Note:** A **Mailing List** cannot include entries stored on the SIM card.



features	
<b>sort phonebook list</b>	<p>Set the order in which entries are listed:</p> <p> &gt;  <b>Phonebook</b>, then press</p> <p> &gt; <b>Setup</b> &gt; <b>Sort by</b> &gt; <i>sort order</i></p> <p>You can sort the phonebook list by <b>Name</b>, <b>Speed No.</b>, <b>Voice Name</b>, or <b>Email</b>. When sorting by name, you can see <b>All</b> numbers or just the <b>Primary</b> number for each name.</p>
<b>copy one phonebook entry</b>	<p>Copy an entry from the phone to the SIM card, or from the SIM card to the phone:</p> <p> &gt;  <b>Phonebook</b>, scroll to the entry, press  &gt; <b>Copy</b> &gt; <b>Entries</b> &gt; <b>To</b></p>

## messages











For basic multimedia message features, see page 25.

















features	
<b>send text message</b>	<p> &gt; <b>Create Message</b> &gt; <b>New Short Msg</b> </p>
<b>send voice message</b>	<p> &gt; <b>Create Message</b> &gt; <b>New Voice Msg</b> </p> <p>To record the voice message, press the <b>Record</b> key, speak, then press the <b>Stop</b> key. Your phone inserts the voice recording into a message and lets you enter email addresses or phone numbers to receive the message.</p>

<b>features</b>	
<b>use a multimedia template</b>	<p>Open a multimedia message with preloaded animations: </p> <p> &gt; <b>Create Message</b> &gt; <b>MMS Templates</b></p>
<b>read and manage messages</b>	<p> &gt; <b>Message Inbox</b> </p> <p>Icons next to each message indicate if it is read  or unread . Icons can also indicate if the message is locked , urgent , low priority , or has an attachment .</p> <p>To see message options like <b>Reply</b>, <b>Forward</b>, <b>Lock</b>, or <b>Delete</b>, scroll to a message and press .</p>
<b>store message objects</b>	<p>Go to a multimedia message page, or scroll to an object in a message, then: </p> <p> &gt; <b>Store</b></p>
<b>store text messages on your SIM card</b>	<p>To store incoming text messages on your SIM card, press: </p> <p> &gt;  <b>Messages</b>, then press</p> <p> &gt; <b>Message Setup</b> &gt; <b>Text Msg Setup</b> &gt; <b>Store To</b> &gt; <b>SIM</b></p> <p>  &gt; <b>Inbox Setup</b> &gt; <b>Text Msg Setup</b> &gt; <b>Store To</b> &gt; <b>SIM</b></p>
<b>browser messages</b>	<p>Read messages received by your micro-browser: </p> <p> &gt; <b>Browser Msgs</b></p>







features		
<b>info services</b>	Read subscription-based information services messages:  > <b>Info Services</b>	

## instant messaging











features		
<b>log in</b>	 >  <b>IM</b> > <b>Log In</b>	
<b>add contacts</b>	After you log in: Select <b>Contact List</b> > <b>Add Contact</b> and enter the contact's IM ID and nickname.	
<b>find others online</b>	After you log in: Select <b>Contact List</b> to see a list of others online.	
<b>start conversation</b>	From your <b>Contact List</b> , scroll to a name in <b>Online Contacts</b> , press the <b>Send IM</b> key.	
<b>open active conversation</b>	From your <b>Contact List</b> , scroll to a name in <b>Conversations</b> , press the <b>View</b> key.	
<b>end conversation</b>	From the conversation view:  > <b>End Conversation</b>	
<b>log out</b>	Select <b>Log Out</b> from the <b>IM Online</b> menu.	















features	
<b>create or change IM accounts</b>	 >  IM > IM Account  <p>Select an IM account, or select <b>New</b> to create a new IM account.</p>
<b>log in automatically</b>	 >  IM > Offline Settings  <p>Turn on <b>Auto-Login</b> to start the IM login whenever you select  &gt; IM. Turn on <b>Power-On Login</b> to start the IM login whenever you turn on your phone.</p>
<b>hide your online status</b>	 <p>When you log in, other users can see you are <b>Online</b>. To change your status in IM, press  &gt; <b>My Status</b> &gt; <b>Away</b> or <b>Invisible</b>.</p>
<b>block contacts</b>	 <p>To block instant messages from a contact, scroll to the contact in the <b>Contact List</b> and press  &gt; <b>Block Contact</b>. You must be online to block a contact. Blocked contacts will not appear in your <b>Contact List</b>.</p>
<b>set alerts for contacts</b>	 <p>When a special contact comes online, your phone can ring or vibrate. Scroll to the contact in the <b>Contact List</b> and press  &gt; <b>Set Online Alert</b>.</p>
<b>set IM ring style</b>	 <p>Select a ring or vibration for new IM messages and contact alerts.</p> <p> &gt;  Settings &gt; Ring Styles &gt; <i>style</i> Detail &gt; IM</p>









# chat

features	
<b>start chat</b>	 >  Tools > Chat, then press  > New Chat 
<b>receive chat request</b>	Press the <b>Accept</b> key or the <b>Ignore</b> key. 
<b>end chat</b>	During a chat session:  > End Chat 

# personalizing

features	
<b>language</b>	Set menu language:  >  Settings > Initial Setup > Language
<b>scroll</b>	Set the scroll bar to stop or wrap around in menu lists:  >  Settings > Initial Setup > Scroll
<b>activate ringer IDs</b>	Activate ringer IDs assigned to phonebook entries and categories:  >  Settings > Ring Styles > <i>style</i> Detail > Ringer IDs
<b>ring volume</b>	Press  >  Settings > Ring Styles > <i>style</i> Detail > Ring Volume
<b>keypad volume</b>	Press  >  Settings > Ring Styles > <i>style</i> Detail > Key Volume

<b>features</b>	
<b>reminders</b>	<p>Set reminder alerts for messages that you receive:</p> <p>Press  &gt;  <b>Settings</b> &gt; <b>Ring Styles</b> &gt; <i>style</i> <b>Detail</b> &gt; <b>Reminders</b></p>
<b>headline view</b>	<p>If your home screen shows scrolling headlines from your service provider, you can turn them on or off:  </p> <p> &gt;  <b>Settings</b> &gt; <b>Personalize</b> &gt; <b>Home Screen</b> &gt; <b>Headlines</b> &gt; <b>On</b> or <b>Off</b></p> <p>In the <b>Home Screen</b> menu, you can also add or change headline channels.</p>
<b>menu view</b>	<p>Show the main menu as graphic icons or as a text-based list:</p> <p> &gt;  <b>Settings</b> &gt; <b>Personalize</b> &gt; <b>Main Menu</b> &gt; <b>View</b></p>
<b>main menu</b>	<p>Reorder your phone's main menu:</p> <p> &gt;  <b>Settings</b> &gt; <b>Personalize</b> &gt; <b>Main Menu</b> &gt; <b>Reorder</b></p>
<b>show/hide menu icons</b>	<p>Show or hide menu feature icons in the home screen:</p> <p> &gt;  <b>Settings</b> &gt; <b>Personalize</b> &gt; <b>Home Screen</b> &gt; <b>Home Keys</b> &gt; <b>Icons</b></p> <p><b>Note:</b> This option is not available if your home screen shows scrolling headlines from your service provider.  </p>









<b>features</b>	
<b>change home keys</b>	<p>Change the features for the soft keys and navigation key in the home screen:</p> <p> &gt;  <b>Settings</b> &gt; <b>Personalize</b> &gt; <b>Home Screen</b> &gt; <b>Home Keys</b></p> <p><b>Note:</b> This option is not available if your home screen shows scrolling headlines from your service provider. </p>
<b>shortcuts</b>	<p>Create a shortcut to a menu item:</p> <p>Scroll to the menu item, then press and hold .</p> <p>Use a shortcut:</p> <p>Press , then press the shortcut number.</p>
<b>master reset</b>	<p>Reset all options <b>except</b> unlock code, security code, and lifetime timer:</p> <p> &gt;  <b>Settings</b> &gt; <b>Initial Setup</b> &gt; <b>Master Reset</b></p>
<b>master clear</b>	<p><b>Caution:</b> Master clear <b>erases all information you have entered</b> (including phonebook and datebook entries) <b>and content you have downloaded</b> (including photos and sounds) stored in your phone's memory. After you erase the information, you can't recover it.</p> <p> &gt;  <b>Settings</b> &gt; <b>Initial Setup</b> &gt; <b>Master Clear</b></p>



## call times & costs

















**Network connection time** is the elapsed time from the moment you connect to your service provider's network to the moment you end the call by pressing . This time includes busy signals and ringing.

**The amount of network connection time you track on your resettable timer may not equal the amount of time for which you are billed by your service provider. For billing information, contact your service provider.**

features		
<b>call times</b>	Show call timers:  >  Recent Calls > Call Times	
<b>in-call timer</b>	Show time or cost information during a call:  >  Settings > In-Call Setup > In-Call Timer	
<b>call cost</b>	Show call cost trackers:  >  Recent Calls > Call Cost	











## handsfree

**Note:** The use of wireless devices and their accessories may be prohibited or restricted in certain areas. Always obey the laws and regulations on the use of these products.



features	
<b>speakerphone</b>	<p>Activate the speakerphone during a call:</p> <p>Press the <b>Speaker</b> key (if available, or  &gt; <b>Spkrphone On</b>).</p>
<b>auto answer</b> (car kit or headset)	<p>Automatically answer calls when connected to a car kit or headset: </p> <p> &gt;  <b>Settings</b> &gt; <b>Car Settings</b> or <b>Headset</b> &gt; <b>Auto Answer</b></p>
<b>voice dial</b> (headset)	<p>Enable voice dial with headset send/end key: </p> <p> &gt;  <b>Settings</b> &gt; <b>Headset</b> &gt; <b>Voice Dial</b></p>
<b>auto handsfree</b> (car kit)	<p>Automatically route calls to a car kit when connected: </p> <p> &gt;  <b>Settings</b> &gt; <b>Car Settings</b> &gt; <b>Auto Handsfree</b></p>
<b>power-off delay</b> (car kit)	<p>Set the phone to stay on for a specified time after the ignition is switched off: </p> <p> &gt;  <b>Settings</b> &gt; <b>Car Settings</b> &gt; <b>Power-Off Delay</b></p>
<b>charger time</b> (car kit)	<p>Charge the phone for a specified time after the ignition is switched off: </p> <p> &gt;  <b>Settings</b> &gt; <b>Car Settings</b> &gt; <b>Charger Time</b></p>

# data & fax calls













To connect your phone with a USB cable, see page 27.

features	
<b>send data or fax</b>	Connect your phone to the device, then place the call through the device application. 
<b>receive data or fax</b>	Connect your phone to the device, then answer the call through the device application. 
<b>talk then fax</b>	Connect your phone to the device, enter fax number, press   > <b>Talk then Fax</b> , then press  to make the call.
<b>using sync</b>	You can call an Internet server and synchronize your phonebook and datebook entries with the server.   To <b>set up</b> an Internet sync partner, press  >  <b>Settings</b> > <b>Sync</b> > <b>[New Entry]</b> . Enter the server details, including <b>Server URL</b> (you can omit <b>http://</b> ) and <b>Data Path</b> (the folder below the URL where your data is stored).  To <b>synchronize files</b> with a partner you set up, select the partner from the list in  >  <b>Settings</b> > <b>Sync</b> .

# network



features	
<b>network settings</b>	See network information and adjust network settings: 
 >  <b>Settings</b> > <b>Network</b>	

# personal organizer

features	
<b>set alarm</b>	 >  <b>Tools</b> > <b>Alarm Clock</b>
<b>turn off alarm</b>	When an alarm happens: To turn off the alarm, press the <b>Disable</b> key or  . To set an 8 minute delay, press the <b>Snooze</b> key.
<b>add new datebook event</b>	 >  <b>Tools</b> > <b>Datebook</b> , scroll to the day, press  , press  > <b>New</b>
<b>see datebook event</b>	See or edit event details:  >  <b>Tools</b> > <b>Datebook</b> , scroll to the day, press  , press the <b>View</b> key
<b>event reminder</b>	When an event reminder happens: To see reminder details, press the <b>View</b> key. To close the reminder, press the <b>Exit</b> key.
<b>calculator</b>	 >  <b>Tools</b> > <b>Calculator</b>

## features

### currency converter

 >  **Tools** > **Calculator**, then press  
 > **Exchange Rate**

Enter exchange rate, press the **OK** key, enter amount, and press

 > **Convert Currency**.

## security

## features

### SIM PIN

**Caution:** If you enter an incorrect PIN code 3 times in a row, your SIM card is disabled and your display shows **SIM Blocked**.

Lock or unlock the SIM card:

 >  **Settings** > **Security** > **SIM PIN**

### lock feature

 >  **Settings** > **Security** > **Lock Application**

### manage certificates

Enable or disable Internet access certificates stored on your phone:















 >  **Settings** > **Security** > **Certificate Mgmt**

Certificates are used to verify the identity and security of Web sites when you download files or share information.

# fun & games

**Note:** A lock (🔒) icon next to a picture, sound, or other object means that you cannot send or copy it.

features	
<b>view, delete, or manage pictures</b>	Manage photos, pictures, and animations:   >  <b>Multimedia</b> > <b>Pictures</b>
<b>view, delete, or manage video clips</b>	 >  <b>Multimedia</b> > <b>Videos</b>
<b>hear, delete, or manage sounds</b>	Manage ring tones and music that you have downloaded or composed:  >  <b>Multimedia</b> > <b>Sounds</b>
<b>create ring tones</b>	Create ring tones that you can use with your phone:  >  <b>Multimedia</b> > <b>Sounds</b> > <b>[New iMelody]</b>
<b>start micro-browser</b>	Just press  . 
<b>download objects from Web page</b>	Download a picture, sound, or other object from a Web page:  Press  , go to the page that links to the file, scroll to the link, and select it. <b>Note:</b> Normal airtime and/or carrier usage charges apply.

## features

### Web sessions

A *Web Session* stores settings that your phone uses to access the Internet. To select or create a Web session:



 >  **Web Access** > **Web Sessions**

### download game or application

You can download a Java™ game or application the same way you download pictures or other objects:





Press , go to the page that links to the file, scroll to the link, and select it.

**Note:** Normal airtime and/or carrier usage charges apply.

### start game or application

Start a Java™ game or application:

 >  **Games & Apps**, scroll to the game or application, press the *center key* .



# service and repairs

---

If you have questions or need assistance, we're here to help.

Go to [www.motorola.com/consumer/support](http://www.motorola.com/consumer/support), where you can select from a number of customer care options. You can also contact the Motorola Customer Support Center at 1-800-331-6456 (United States), 1-888-390-6456 (TTY/TDD United States for hearing impaired), or 1-800-461-4575 (Canada).



# ***Specific Absorption Rate Data***

---

## **The model wireless phone meets the government's requirements for exposure to radio waves.**

Your wireless phone is a radio transmitter and receiver. It is designed and manufactured not to exceed limits for exposure to radio frequency (RF) energy set by the Federal Communications Commission (FCC) of the U.S. Government and by the Canadian regulatory authorities. These limits are part of comprehensive guidelines and establish permitted levels of RF energy for the general population. The guidelines are based on standards that were developed by independent scientific organizations through periodic and thorough evaluation of scientific studies. The standards include a substantial safety margin designed to assure the safety of all persons, regardless of age or health.

The exposure standard for wireless mobile phones employs a unit of measurement known as the Specific Absorption Rate, or SAR. The SAR limit set by the FCC and by the Canadian regulatory authorities is  $1.6 \text{ W/kg}^1$ . Tests for SAR are conducted using standard operating positions accepted by the FCC and by Industry Canada with the phone transmitting at its highest certified power level in all tested frequency bands. Although the SAR is determined at the highest certified power level, the actual SAR level of the phone while operating can be well below the maximum value. This is because the phone is designed to operate at multiple power levels so as to use only the power required to reach the network. In general, the closer you are to a wireless base station, the lower the power output.

Before a phone model is available for sale to the public in the U.S. and Canada, it must be tested and certified to the FCC and Industry Canada that it does not exceed the limit established by each government for safe exposure. The tests are performed in positions and locations (e.g., at the ear and worn on the body) reported to the FCC and available for review by Industry Canada. The highest SAR value for this model phone when tested for use at the ear is  $1.38 \text{ W/kg}$ , and when worn on the body, as

described in this user guide, is 0.35 W/kg. (Body-worn measurements differ among phone models, depending upon available accessories and regulatory requirements).<sup>2</sup>

While there may be differences between the SAR levels of various phones and at various positions, they all meet the governmental requirements for safe exposure. Please note that improvements to this product model could cause differences in the SAR value for later products; in all cases, products are designed to be within the guidelines.

Additional information on Specific Absorption Rates (SAR) can be found on the Cellular Telecommunications & Internet Association (CTIA) Web site:

<http://www.phonefacts.net>

or the Canadian Wireless Telecommunications Association (CWTA) Web site:

<http://www.cwta.ca>

1. In the United States and Canada, the SAR limit for mobile phones used by the public is 1.6 watts/kg (W/kg) averaged over one gram of tissue. The standard incorporates a substantial margin of safety to give additional protection for the public and to account for any variations in measurements.
2. The SAR information includes the Motorola testing protocol, assessment procedure, and measurement uncertainty range for this product.

# Motorola Limited Warranty for the United States and Canada

---

## What Does this Warranty Cover?

Subject to the exclusions contained below, Motorola, Inc. warrants its telephones, pagers, messaging devices, and consumer and professional two-way radios (excluding commercial, government or industrial radios) that operate via Family Radio Service or General Mobile Radio Service, Motorola-branded or certified accessories sold for use with these Products ("Accessories") and Motorola software contained on CD-ROMs or other tangible media and sold for use with these Products ("Software") to be free from defects in materials and workmanship under normal consumer usage for the period(s) outlined below. This limited warranty is a consumer's exclusive remedy, and applies as follows to new Motorola Products, Accessories and Software purchased by consumers in the United States or Canada, which are accompanied by this written warranty:

### Products and Accessories

<b>Products Covered</b>	<b>Length of Coverage</b>
<b>Products and Accessories</b> as defined above, unless otherwise provided for below.	<b>One (1) year</b> from the date of purchase by the first consumer purchaser of the product unless otherwise provided for below.
<b>Decorative Accessories and Cases.</b> Decorative covers, bezels, PhoneWrap™ covers and cases.	<b>Limited lifetime warranty</b> for the lifetime of ownership by the first consumer purchaser of the product.

<b>Products Covered</b>	<b>Length of Coverage</b>
<b>Monaural Headsets.</b> Ear buds and boom headsets that transmit mono sound through a wired connection.	<b>Limited lifetime warranty</b> for the lifetime of ownership by the first consumer purchaser of the product.
<b>Consumer and Professional Two-Way Radio Accessories.</b>	<b>Ninety (90) days</b> from the date of purchase by the first consumer purchaser of the product.
<b>Products and Accessories that are Repaired or Replaced.</b>	<b>The balance of the original warranty or for ninety (90) days</b> from the date returned to the consumer, whichever is longer.

## Exclusions

**Normal Wear and Tear.** Periodic maintenance, repair and replacement of parts due to normal wear and tear are excluded from coverage.

**Batteries.** Only batteries whose fully charged capacity falls below 80% of their rated capacity and batteries that leak are covered by this limited warranty.

**Abuse & Misuse.** Defects or damage that result from: (a) improper operation, storage, misuse or abuse, accident or neglect, such as physical damage (cracks, scratches, etc.) to the surface of the product resulting from misuse; (b) contact with liquid, water, rain, extreme humidity or heavy perspiration, sand, dirt or the like, extreme heat, or food; (c) use of the Products or Accessories for commercial purposes or subjecting the Product or Accessory to abnormal usage or conditions; or (d) other acts which are not the fault of Motorola, are excluded from coverage.

**Use of Non-Motorola Products and Accessories.** Defects or damage that result from the use of Non-Motorola branded or certified Products, Accessories, Software or other peripheral equipment are excluded from coverage.

**Unauthorized Service or Modification.** Defects or damages resulting from service, testing, adjustment, installation, maintenance, alteration, or modification in any way by someone other than Motorola, or its authorized service centers, are excluded from coverage.

**Altered Products.** Products or Accessories with (a) serial numbers or date tags that have been removed, altered or obliterated; (b) broken seals or that show evidence of tampering; (c) mismatched board serial numbers; or (d) nonconforming or non-Motorola housings, or parts, are excluded from coverage.

**Communication Services.** Defects, damages, or the failure of Products, Accessories or Software due to any communication service or signal you may subscribe to or use with the Products Accessories or Software is excluded from coverage.

## Software

<b>Products Covered</b>	<b>Length of Coverage</b>
<b>Software.</b> Applies only to physical defects in the media that embodies the copy of the software (e.g. CD-ROM, or floppy disk).	<b>Ninety (90) days</b> from the date of purchase.

## Exclusions

**Software Embodied in Physical Media.** No warranty is made that the software will meet your requirements or will work in combination with any hardware or software applications provided by third parties, that the operation of the software products will be uninterrupted or error free, or that all defects in the software products will be corrected.

**Software NOT Embodied in Physical Media.** Software that is not embodied in physical media (e.g. software that is downloaded from the internet), is provided "as is" and without warranty.

## Who Is Covered?

This warranty extends only to the first consumer purchaser, and is not transferable.

## What Will Motorola Do?

Motorola, at its option, will at no charge repair, replace or refund the purchase price of any Products, Accessories or Software that does not conform to this warranty. We may use functionally equivalent reconditioned/refurbished/pre-owned or new Products, Accessories or parts. No data, software or applications added to your Product, Accessory or Software, including but not limited to personal contacts, games and ringer tones, will be reinstalled. To avoid losing such data, software and applications please create a back up prior to requesting service.

## How to Obtain Warranty Service or Other Information

<b>USA</b>	<b>Phones</b> 1-800-331-6456 <b>Pagers</b> 1-800-548-9954 <b>Two-Way Radios and Messaging Devices</b> 1-800-353-2729
<b>Canada</b>	<b>All Products</b> 1-800-461-4575
<b>TTY</b>	1-888-390-6456
For <b>Accessories</b> and <b>Software</b> , please call the telephone number designated above for the product with which they are used.	

You will receive instructions on how to ship the Products, Accessories or Software, at your expense, to a Motorola Authorized Repair Center. To obtain service, you must include: (a) a copy of your receipt, bill of sale or other comparable proof of purchase; (b) a written description of the problem; (c) the name of your service provider, if applicable; (d) the name and location of the installation facility (if applicable) and, most importantly; (e) your address and telephone number.

## What Other Limitations Are There?

ANY IMPLIED WARRANTIES, INCLUDING WITHOUT LIMITATION THE IMPLIED WARRANTIES OF MERCHANTABILITY AND FITNESS FOR A PARTICULAR PURPOSE, SHALL BE LIMITED TO THE DURATION OF THIS LIMITED WARRANTY, OTHERWISE THE REPAIR, REPLACEMENT, OR REFUND AS PROVIDED UNDER THIS EXPRESS LIMITED WARRANTY IS THE EXCLUSIVE REMEDY OF THE CONSUMER, AND IS PROVIDED IN LIEU OF ALL OTHER WARRANTIES, EXPRESS OR IMPLIED. IN NO EVENT SHALL MOTOROLA BE LIABLE, WHETHER IN CONTRACT OR TORT (INCLUDING NEGLIGENCE) FOR DAMAGES IN EXCESS OF THE PURCHASE PRICE OF THE PRODUCT, ACCESSORY OR SOFTWARE, OR FOR ANY INDIRECT, INCIDENTAL, SPECIAL OR CONSEQUENTIAL DAMAGES OF ANY KIND, OR LOSS OF REVENUE OR PROFITS, LOSS OF BUSINESS, LOSS OF INFORMATION OR DATA, SOFTWARE OR APPLICATIONS OR OTHER FINANCIAL LOSS ARISING OUT OF OR IN CONNECTION WITH THE ABILITY OR INABILITY TO USE THE PRODUCTS, ACCESSORIES OR SOFTWARE TO THE FULL EXTENT THESE DAMAGES MAY BE DISCLAIMED BY LAW.

**Some states and jurisdictions do not allow the limitation or exclusion of incidental or consequential damages, or limitation on the length of an implied warranty, so the above limitations or exclusions may not apply to you. This warranty gives you specific legal rights, and you may also have other rights that vary from state to state or from one jurisdiction to another.**

Laws in the United States and other countries preserve for Motorola certain exclusive rights for copyrighted Motorola software such as the

exclusive rights to reproduce and distribute copies of the Motorola software. Motorola software may only be copied into, used in, and redistributed with, the Products associated with such Motorola software. No other use, including without limitation disassembly of such Motorola software or exercise of the exclusive rights reserved for Motorola, is permitted.

DRAFT



# Information from the World Health Organization

---

Present scientific information does not indicate the need for any special precautions for the use of mobile phones. If you are concerned, you may want to limit your own or your children's RF exposure by limiting the length of calls or by using handsfree devices to keep mobile phones away from your head and body.

Source: WHO Fact Sheet 193

Further information: <http://www.who.int./peh-emf>

# index

---

## A

accessories 17, 71  
accessory connector port 1  
active line indicator 30  
active line, changing 58  
alarm clock 74  
alert  
    lights 42  
    set 39, 41  
    turn off 38, 39, 46  
animation 76  
answer a call 21, 45  
attach a number 47, 56

## B

backlight 44  
battery 18, 19  
battery indicator 31  
battery life, extending 20,  
    43, 44  
browser messages 65  
browser. See micro-browser

## C

cables 27  
calculator 74  
call

    answer 21, 45  
    end 21  
    make 21  
call barring 58  
call forward indicator 30  
call forwarding 58  
call timers 71  
call waiting 57  
caller ID 47, 48, 61  
car kit 71  
center key 1, 39  
center select key 17  
certificate management 75  
chat 68  
clock 42  
codes 40  
color 44  
conference call 57  
costs, tracking 71

## D

data call 73  
data indicator 29  
date, setting 42  
datebook 74  
dial a phone number 21, 59  
dialed calls 46

display 28, 44, 69  
download media objects  
65, 76  
drafts folder 26  
DTMF tones 47, 59

## **E**

earpiece volume 38  
emergency number 48  
end a call 21  
end key 1, 21  
Enter Unlock Code  
message 40  
event lights 42  
external display 39

## **F**

fax call 47, 73  
fixed dial 59  
flip 21, 45  
forward calls 58

## **G**

games 77  
GPRS indicator 29  
group mailing list 63

## **H**

handsfree speaker 39  
headset 71

headset jack 1  
hold a call 57  
home screen 28, 69, 70

## **I**

IM 66  
IM indicators 30  
in-call indicator 30  
Incoming Call message 48  
information services 66  
instant messaging. See IM  
international access code  
57  
iTAP text entry mode 35

## **J**

Java applications 77  
Java indicator 30

## **K**

keypad 45, 68

## **L**

language 68  
light 42  
light ID 62  
lock  
application 75  
phone 40  
SIM card 75

Low Battery message 31

## M

make a call 21  
master clear 70  
master reset 70  
menu 17, 32, 68, 69  
menu icons 32, 69  
menu indicator 28  
message 64, 65  
message indicator 26, 31  
message reminders 69  
micro-browser 65, 76, 77  
Missed Calls message 48  
MMS, defined 25  
MP3 sound files 42  
multimedia message 25, 65  
music 76  
mute a call 57

## N

navigation key 1, 17, 39  
network settings 74  
notepad 56  
number. See phone number  
numeric entry mode 38

## O

1-touch dial 55  
open to answer 45  
optional accessory 17

optional feature 17

## P

passwords. See codes  
personalize 68  
phone number 22, 58  
phonebook 47, 55, 56, 60  
photo 76  
picture 76  
picture ID 48, 61  
PIN code 21, 40, 75  
PIN2 code 40  
power key 1, 21  
PTT 50  
calls, answering 51  
calls, making 50  
contacts and groups 52  
icons 53  
indicator 30  
locking key 53  
Quick Groups 50  
settings 53  
turning on or off 53  
Push to Talk. See PTT

## Q

quick dial 59

## R

received calls 46  
recent calls 46

redial 47  
reminders 69  
restrict calls 58  
return a call 48  
ring lights 42  
ring style indicator 31  
ring style, setting 39, 41  
ring tone 76  
ringer ID 48, 61, 68  
ringer volume 38, 68  
roam indicator 30

## S

screen saver 43  
SCREEN3 28, 69  
security code 40  
send key 1, 21  
shortcuts 70  
signal strength indicator 29  
SIM 65  
SIM Blocked message 21,  
75  
SIM card 17, 21, 40, 75  
soft keys 1, 28, 70  
speakerphone 71  
speed dial 56  
store your number 22  
symbol entry mode 38  
synchronizing 73

## T

tap text entry mode 36  
telephone number. See  
phone number  
text entry 34  
text message 64, 65  
time, setting 42  
timers 71  
transfer a call 58  
TTY device 58  
turn on/off 21

## U

unlock  
application 75  
phone 21, 40  
SIM card 75  
unlock code 40  
USB cables 27

## V

video clip 76  
videos 24  
voice dial 61, 72  
voice message 64  
voice name, recording 60  
voicemail 49  
voicemail message indicator  
31, 49  
volume 38, 68

## **W**

wallpaper 43

warranty 81

Web pages 76

Web sessions 77

## **Y**

your phone number 22

U.S. patent Re. 34,976

**motorola.com**