

APPLICANT: MOTOROLA, INC.

FCC ID: IHDT56FY1

**INSTRUCTION MANUAL**

A preliminary draft copy of the Users Manual follows:



# ***MOTOMANUAL***

C257  
GSM

# HELLOMOTO

---

Welcome to the world of Motorola digital wireless communications! We are pleased that you have chosen the Motorola C257 wireless phone.

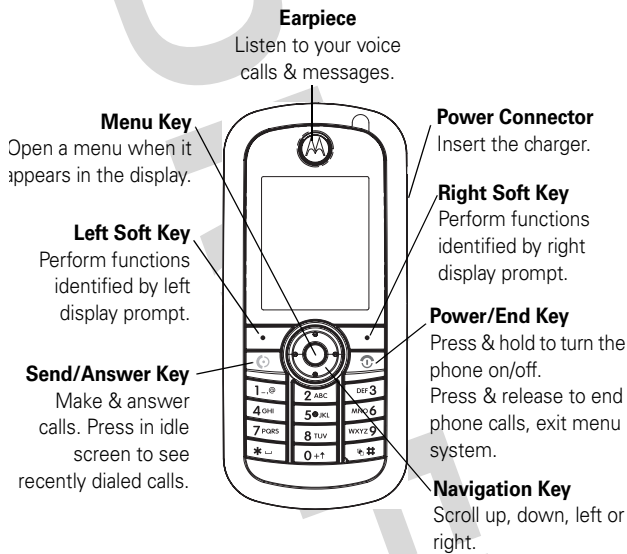

## check it out!

---

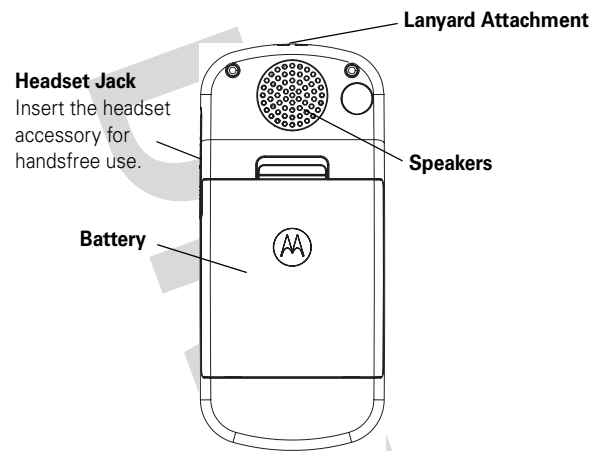

**Note:** Your phone may not appear exactly as the phone image above.

Motorola, Inc.  
Consumer Advocacy Office  
1307 East Algonquin Road  
Schaumburg, IL 60196

[www.hellomoto.com](http://www.hellomoto.com)

1-800-331-6456 (United States)

1-888-390-6456 (TTY/TDD United States for hearing impaired)

1-800-461-4575 (Canada)

MOTOROLA and the Stylized M Logo are registered in the US Patent & Trademark Office. 200x All other product or service names are the property of their respective owners. © Motorola, Inc. 2005.

**Caution:** Changes or modifications made in the radio phone, not expressly approved by Motorola, will void the user's authority to operate the equipment.









Certain mobile phone features are dependent on the capabilities and settings of your service provider's network. Additionally, certain features may not be activated by your service provider, and/or the provider's network settings may limit the feature's functionality. Always contact your service provider about feature availability and functionality. All features, functionality, and other product specifications, as well as the information contained in this user's guide are based upon the latest available information and are believed to be accurate at the time of printing. Motorola reserves the right to change or modify any information or specifications without notice or obligation.

Manual Number: 680XXXAXX-0

# feature locator

---

## main menu

-  **Phonebook**
-  **Recent Calls**
  - Received calls
  - Dialed Calls
  - NotePad
  - Call Times
  - Call Costs
-  **Message**
  - Create
  - Inbox
  - Draft
  - Outbox
  - Quick Notes
  - Voicemail
  - Browser Msgs
  - Info Services
  - MMS Templates
-  **Office Tools**
  - Calculator
  - MyMenu
  - Alarm Clock
  - Stop Watch
  - Chat
  - Dialing Services
  - IM
-  **Games & Apps**
-  **Web Access**
  - Start Browser
  - Web Shortcut
  - Go to URL
  - Browser Setting
  - Stored Pages
  - History
  - General Setting
-  **Multimedia**
  - Pictures
  - Sounds
-  **Personalize**
  - Home Screen
  - Main Menu
  - Color Setting
  - Greeting
  - Wallpaper
  - Screen Saver
  - Quick Dial
-  **Settings**
  - (see next page)

## settings menu



### Ring Style

- Style
- Detail



### Call Forward

- Voice Calls
- Fax Calls
- Data Calls
- Cancel All
- Forward Status



### In Call Setup

- In-Call Timer
- Call Cost Setup
- My Caller ID
- Answer Options
- Call Waiting



### Initial Setup

- Time and Date
- 1-Touch Dial
- Display Settings
- Backlight
- Scroll
- Language
- Contrast
- DTMF
- Master Reset
- Master Clear



### Phone Status

- My Numbers
- Active Line
- Battery Meter



### Headset

- Auto Answer



### Network

- New Network
- Network Setup
- Avail. Networks
- My Network List
- Service Tone
- Call Drop Tone
- Band Selection



### Security

- Phone Lock
- Lock Keypad
- Auto Key Lock
- Fixed Dial
- Call Barring
- SIM PIN
- New Passwords

# contents

---

<b>check it out!</b> . . . . .	<b>2</b>	<b>customize</b> . . . . .	<b>31</b>
<b>feature locator</b> . . . . .	<b>4</b>	ring style . . . . .	31
<b>contents</b> . . . . .	<b>6</b>	time & date . . . . .	31
<b>essentials</b> . . . . .	<b>9</b>	wallpaper . . . . .	32
about this guide . . . . .	9	screen saver . . . . .	32
SIM card . . . . .	9	display appearance . .	33
battery . . . . .	10	answer options . . . . .	33
turn it on & off . . . . .	12	personal greetings . .	33
make a call . . . . .	13	optional handsfree	
answer a call . . . . .	13	operation . . . . .	34
your phone number . .	13	<b>calls</b> . . . . .	<b>35</b>
<b>main attractions</b> . . . . .	<b>14</b>	recent calls . . . . .	35
multimedia messages	14	redial . . . . .	36
using instant messaging	16	return a call . . . . .	36
<b>basics</b> . . . . .	<b>20</b>	notepad . . . . .	36
display . . . . .	20	hold or mute a call . .	37
menus . . . . .	23	call waiting . . . . .	37
text entry . . . . .	25	caller ID . . . . .	38
volume . . . . .	28	emergency calls . . . .	38
navigation key . . . . .	29	international calls . . .	39
handsfree speaker . .	29	1-Touch dial . . . . .	39
codes & passwords . .	29	voicemail . . . . .	40
lock & unlock phone .	30	inserting special	
		characters into dialing	
		sequences . . . . .	40



**other features . . . . . 42**  
advanced calling . . . . . 42  
phonebook . . . . . 44  
messages . . . . . 47  
instant messaging . . . . . 49  
chat . . . . . 50  
personalizing . . . . . 50  
call times & costs . . . . . 52  
handsfree operation . . . . . 53  
network . . . . . 54  
personal organizer . . . . . 54  
fun & games . . . . . 56

**service and repairs . . . . . 57**  
check here first . . . . . 57  
service and repairs . . . . . 58

## European Union Directives Conformance Statement

---



 Hereby, Motorola declares that this product is in compliance with:

- The essential requirements and other relevant provisions of Directive 1999/5/EC
- All other relevant EU Directives

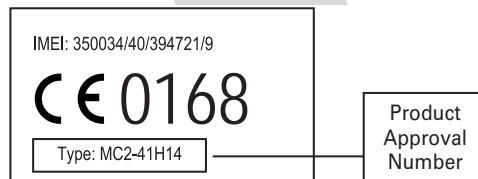

The above gives an example of a typical Product Approval Number.

You can view your product's Declaration of Conformity (DoC) to Directive 1999/5/EC (to R&TTE Directive) at [www.motorola.com/rtte](http://www.motorola.com/rtte). To find your DoC, enter the product Approval Number from your product's label in the "Search" bar on the Web site.

# essentials

---



## about this guide

This guide shows how to locate a menu feature as follows:

**Find it :** Press  > **Recent Calls** > **Dialed Calls**

This example shows that, from the home screen, you press  to open the menu, highlight and select **Recent Calls**, then highlight and select **Dialed Calls**.

Press  to scroll to and highlight a menu feature. Press the **SELECT** key to select the highlighted menu feature.

symbols	
	This means a feature depends on the network or subscription and may not be available in all areas. Contact your service provider for more information.
	This means a feature requires an optional accessory.

## SIM card

Your *Subscriber Identity Module* (SIM) card contains personal information like your phone number and phonebook entries.

**Caution:** Do not bend or scratch your SIM card. Keep it away from static electricity, water, and dirt.

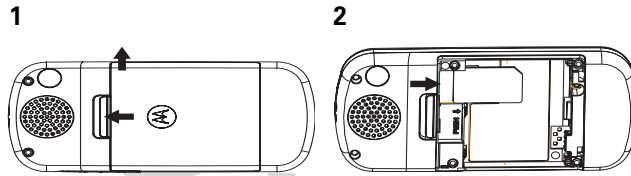

battery

battery installation

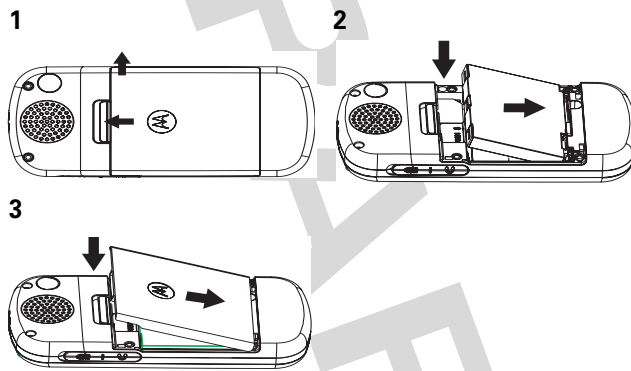

**Note:** If you remove the battery for a long time, the phone will ask you to reset the time and date. If you choose to cancel or ignore, the time and date will be suspended. You can input the correct time and date by:

**Find it:** Press  > **Setting** > **Other Settings** > **Initial Setup** > **Time and Date**

But, if you remove the battery just for a few seconds (e.g., quickly change SIM card), the system either won't ask you to reset the time and date or if prompted, you can choose **BACK** on the time and date screen, the clock will only be slightly affected.

## battery charging

Before you can use your phone you need to completely charge the battery. New batteries are not fully charged. Plug the travel charger into your phone and an electrical outlet. Your phone displays **Charge Complete** when finished.



**Power Connector**  
Insert the charger.

**Tip:** You cannot overcharge your battery. It will perform best after you fully charge and discharge it a few times.

New batteries are shipped partially charged. Before you can use your phone, install and charge the battery as described below. Some batteries perform best after several full charge/discharge cycles.

## battery tips

Battery life depends on the network, signal strength, temperature, features, and accessories you use.

- Always use Motorola Original™ batteries and chargers. The warranty does not cover damage caused by non-Motorola batteries and/or chargers.



- New batteries or batteries stored for a long time may take more time to charge.
- When charging your battery, keep it near room temperature.
- When storing your battery, keep it uncharged in a cool, dark, dry place, such as a refrigerator.
- Never expose batteries to temperatures below -10°C (14°F) or above 45°C (113°F). Always take your phone with you when you leave your vehicle.
- It is normal for batteries to gradually wear down and require longer charging times. If you notice a change in your battery life, it is probably time to purchase a new battery.



Contact your local recycling center for proper battery disposal.

**Warning:** Never dispose of batteries in a fire because they may explode.

Before using your phone, read the battery safety information in the “Safety and General Information” section included in the gray-edged pages at the back of this guide.

## turn it on & off

To turn on your phone, press and hold  for 2 seconds. If prompted, enter your 6-digit SIM card PIN code and/or 4-digit unlock code.

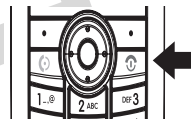

**Caution:** If you enter an incorrect PIN code 3 times in a row, your SIM card is disabled and your phone displays **SIM Blocked**. Contact your service provider.

To turn off your phone, press and hold  for 2 seconds.

## make a call

Enter a phone number and press  to make a call.

To end the call, press .

## answer a call

When your phone rings and/or vibrates, press  to answer.

To end the call, press .

When your phone rings and/or vibrates, press  to answer.

To end the call, press .

## your phone number

To see your number:

Press  > **Settings** > **Phone Status** > **My Numbers**

To store or edit your name and number on your SIM card, press the **VIEW** key while displaying it. If you don't know your phone number, contact your service provider. 

# main attractions

---

## multimedia messages

For more message features, see page 47.

### send a multimedia message

A *Multimedia Messaging Service* (MMS) message contains pages with text and media objects (including photos, pictures, animations, or sounds). You can send the multimedia message to other phones with MMS and to email addresses. 

**Find it:** Press  > Messages > Create > MMS or MMS Templates

**Note:** The MMS templates can't be downloaded or expanded. You can only use the default template.

- 1 Press keypad keys to enter text on the page (for details about text entry, see page 25).

To insert a **picture, sound, or other object** on the page, press the **INSERT** key or  > **Insert**. Select the file type and the file.

To insert another slide in the message, enter text or objects on the current page and press  > **Insert** > **Add Slide**. You can enter more text and objects on the new page.

- 2 When you finish the message, press the **OK** key.
- 3 Choose one or more people for **Send To**.



To select a **phonebook entry**, highlight the entry and press the **ADD** key. Repeat to add other phonebook entries.

To **enter** a new number, highlight **[One Time Entry]** and press the **SELECT** key.

To **enter and store** a new number, highlight **[New Entry]** and press the **SELECT** key.

- 4** When you finish entering numbers/addresses, press the **DONE** key. Your phone displays the message fields.



To enter a **subject** for the message, highlight **Subject** and press the **CHANGE** key.

To request a **delivery receipt** for the message, highlight **Receipt** and press the **CHANGE** key. Then press the **SELECT** key.

- 5** To **send** the message, press **SEND** key.

To **cancel or save** the message as a **Draft**, press .

## receive a multimedia message

When you receive a multimedia message or letter, your phone plays an alert and displays **New Message** with a message indicator such as . 

Press the **READ** key to open the message.

If a multimedia message contains media objects:

- Photos, pictures, and animations display as you read the message.
- A sound file plays when its slide bar displays.

## using instant messaging

Use *instant messaging* to exchange messages in real time with other wireless phone users. The messages you send display immediately on the other users' phones. 

### logging in to IM

**Find it:** Press  > **Office Tools** > **IM** > **Log In**

- 1 Press keypad keys to enter your **IM ID**
- 2 Press **OK** to submit your **IM ID**
- 3 Press keypad keys to enter your **Password** (case-sensitive)
- 4 Press **OK** to submit your **Password**

**Tip:** To log in automatically next time, scroll to **Offline Settings** > **Auto Login** after you submit your password.

- 5 Press  to scroll to your **Contact List**
- 6 Press **SELECT** to view the **Contact List**

Your **Contact List** is sorted by online status:

- **Conversations** display first. These are online IM users having active conversations with you. Press **VIEW** to open your conversation with them.
- **Online Contacts** are logged in to IM. Press **SEND IM** to send the person a message. A  (busy) indicator shows that someone is busy and unable to respond.
- **Offline Contacts** are logged out of IM. You can press **SEND IM** to send a message, in case the person has logged in since you refreshed your list.

**Note:** To refresh your **Contact List**, press  > **Refresh List** while viewing the list.

## Sending and Receiving Instant Messages



When you log in to IM, you can exchange messages with other IM users.

- 1 Press  to scroll to a name on the **Contact List**
- 2 Press **SEND IM** to start a conversation with the person or press **VIEW** to open a conversation in progress
- 3 Press keypad keys to enter message text
- 4 Press **SEND** to send the message

Your phone displays the conversation history, where you can see the text you sent and the person's replies as they arrive. In the conversation display, you can:

- Press **BACK** to return to the **Contact List**, where you can open more conversations
- Press  to return to the home screen, without logging out of IM or closing the conversation



**Note:** Your phone displays  **New IM** if you receive a message while on the home screen or in another application.

- Press  > **Contact Info** to view the screen name and online status of the person in this conversation
- Press  > **Add Contact** to add the screen name to your Contact List
- Press  > **End Conversation** to end the conversation

**Note:** If you log out of IM, you can still view the conversation text by pressing  > **IM** > **Offline Convs.** from the home screen. Turning off your phone erases the conversations.

## setting your online status

When you log in to IM, your online status is visible to other IM users. To set your online status:

- 1 Press  to scroll to **My Status**
- 2 Press **SELECT** to select the option
- 3 Press  to scroll to **Available, Busy, or Invisible**
- 4 Press **SELECT** to select the status setting

## setting up IM

### adding and removing contacts

To add a name, open your **Contact List** or a conversation and press  > **Add Contact**. If you are not in a conversation, enter the new screen name and press **OK**. IM returns an error if it cannot verify the name on the server.

To remove a name from your **Contact List**, highlight the name and press  > **Delete Contact**.

### setting your busy message

If you are logged in to IM but not responding to new messages, you can set the  (busy) indicator to display next to your name in everyone else's **Contact List**. From the **IM Online** menu, select **My Status** > **Busy**.

To create or edit a busy message that is automatically sent to IM users attempting to contact you, select **Busy Message** from the **IM Online** menu.

**Note:** The **IM Online** menu displays when you log in, and when you press **BACK** from your **Contact List**.

### setting your IM alert

IM can sound an alert when new messages arrive.

To turn the IM alert on or off, select **Settings > Set Sounds** from the **IM Online** menu.

### logging out of IM

Select **Log Out** from the **IM Online** menu.

**Note:** Above introduction is for **Custom**, for the AIM and ICQ will have similar usage process.

## basics

---

See page 1 for a basic phone diagram.

### display

The *home screen* displays when you turn on the phone. To dial a number from the home screen, press the number keys and .

**Note:** Your home screen may look different from the one on this page, depending on your service provider.

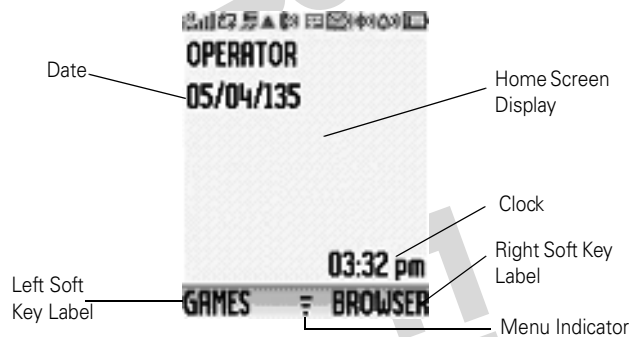



The *menu indicator* shows that you can press  to open the menu. *Soft key* labels show the current soft key functions. For soft key locations, see page 1.



Press  up, down, left, or right to open basic menu features. You may select to show or hide home screen display icons.

**Find it:** Press  > Personalize > Home Screen > Home Keys > Icons



Status indicators can display at the top of the home screen:





**1 Signal Strength Indicator** – Vertical bars show the strength of the network connection. You cannot make or receive calls when  or  displays.



















**2 GPRS Indicator** – Shows when your phone is using a high-speed GPRS network connection. Indicators show PDP context active  or packet data available . 

**3 Data Indicator** – Shows connection status.

 = secure packet data transfer       = unsecure packet data transfer

 = secure application connection       = unsecure application connection

 = secure *Circuit Switch Data* (CSD) call       = unsecure CSD call

- 4 Roam Indicator** – Shows when your phone is seeking or using a network outside of your home network. Indicator shows ▲. 
- 5 Active Line Indicator** – Shows  to indicate an active call, or  to indicate when call forwarding is on. Indicators for dual phone lines (requires SIM card for 2 phone lines) can include:
- |  |  |
|--|--|
|  = line 1 active                  |  = line 2 active                  |
|  = line 1 active, call forward on |  = line 2 active, call forward on |
- 6 Messaging Presence Indicator** – Shows when Instant Messaging (IM) is active. Indicators can include:
- |  |   |
|--|---|
|  = online |  = new message |
|--|---|
- Note:** The IM-related icons above are for Custom IM.
- 7 Message Indicator** – Shows when you receive a new message. Indicators can include: 
- |  |   |
|--|---|
|  = text message             |  = voicemail message   |
|  = voicemail & text message |  = active chat session |
- 8 Location Indicator** – Shows whether *Automatic Location Information* (ALI) about your phone is turned on  or off . 
- 9 Ring Style Indicator** – Shows the ring style setting.
- |   |   |
|---|---|
|  = loud ring |  = vibrate then ring |
|---|---|



🔔 = soft ring  
🔔 = vibrate

🔕 = silent  
🔔🔕 = vibrate & ring





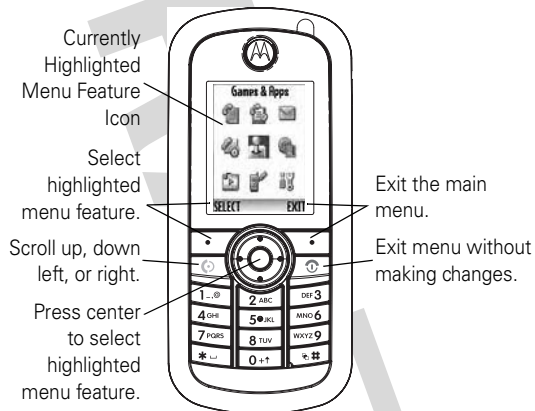

**10 Battery Level Indicator** – Vertical bars show the battery charge level. Recharge the battery when your phone shows **Low Battery**.



## menus

From the home screen, press  to enter the main menu.



The following menu icons may be available, depending on your service provider and service subscription options.

menu features	
 Phonebook	 Web Access
 Recent Calls	 Multimedia
 Messages	 Personalize

 Office Tools	 Settings
 Games & Apps	

Some features require you to select an option from a list:

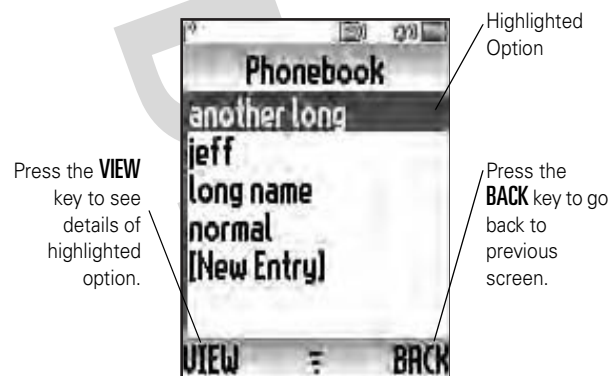

- Scroll up or down to highlight the option you want.
- In a numbered list, press a number key to highlight an option.
- In an alphabetized list, press a key repeatedly to cycle through the letters and highlight the closest matching option on the list.
- When an option has a list of possible settings, scroll left or right to select the setting.
- When an option has a list of possible numeric values, press a number key to set the value.

## text entry

Some features let you enter text.

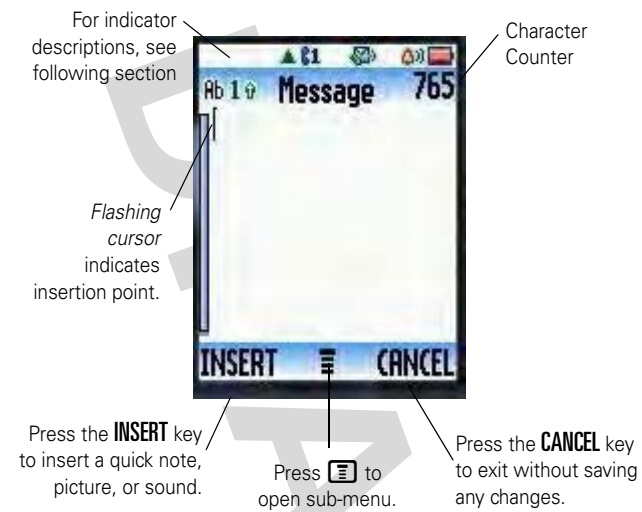

Press **[#]** in any text entry screen to select one of the following entry methods:

<b>Primary</b>	The primary text entry method (see below to set)
<b>Numeric</b>	Enter numbers only (see page 44).
<b>Symbol</b>	Enter symbols only (see page 44).
<b>Secondary</b>	The secondary text entry method (see below to set).

Alternatively, you can select a text entry method in any text entry screen by pressing **[≡] > Entry Mode**.

### iTAP® mode

Press **[#]** in a text entry screen to switch to iTAP mode. If you don't see **[#]** or **[#]**, press **[≡] > Entry Setup** to set iTAP mode as your primary or secondary text entry mode.

iTAP mode lets you enter words using one keypress per letter. The iTAP software combines your keypresses into common words and predicts each word as you enter it.

For example, if you press **7 7 6 4** , your phone displays:



- If you want a different word (such as **Progress**), continue pressing keypad keys to enter the remaining characters.
- Press **[ ]** to enter punctuation or other characters.

### tap mode

Press **[#]** in a text entry screen to switch to tap mode. If you do not see **1** or **2**, press **[ ] > Entry Setup** to set tap mode as your primary or secondary text entry mode.

To enter text in tap mode, press a keypad key repeatedly to cycle through the letters and number on the key. Repeat this step to enter each letter.

For example, if you press **[1]** one time, your phone displays:

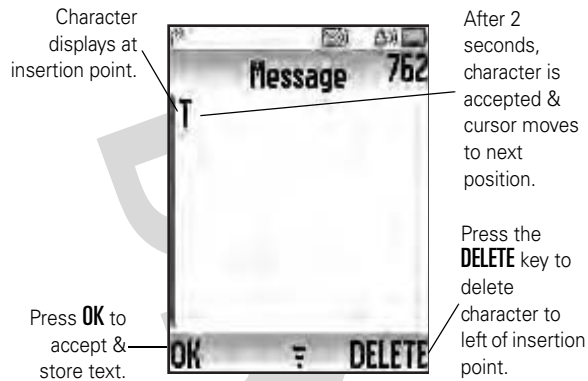

## numeric mode

Press the number keys to enter the numbers you want.

## symbol mode

Press a keypad key to show its symbols at the bottom of the display.

Highlight the symbol you want, then press the **SELECT** key.

## volume

You can adjust the earpiece speaker volume while you are talking by pressing **[VOLUME UP]** right/up to increase the volume or **[VOLUME DOWN]** left/down to decrease the volume.

**Tip:** During a call, you may set your phone to mute by pressing **[MUTE]** > **Mute**.

## navigation key

Press the *Navigation Key*  up, down, left, or right to scroll and highlight options.

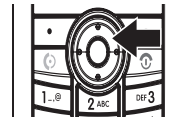

## handsfree speaker

You can use your phone's handsfree speaker to make calls without holding the phone to your ear.

During a call, press the **H.FREE** key to turn the handsfree speaker on or off. Your phone displays **Spkrphone On** until you turn it off or end the call.

**Note:** The handsfree speaker does not work when your phone is connected to a handsfree car kit or headset.

## codes & passwords

Your phone's 4-digit **unlock code** is originally set to **1234**. The 6-digit **security code** is originally set to **000000**. If your service provider didn't change these codes, you should change them:

**Find it:** Press  > **Settings** > **Security** > **New Passwords**

You can also change your **SIM PIN** or call barring passwords.

**If you forget your unlock code:** At the **Enter Unlock Code** prompt, try entering 1234 or the last four digits of your phone number. If that doesn't work, press  and enter your 6-digit security code instead.

**If you forget your security code:** If you forget your security code, SIM PIN code, PIN2 code, or call barring password, contact your service provider.

## lock & unlock phone

You can lock your phone to keep others from using it. To lock or unlock your phone, you need the 4-digit unlock code.

To **manually lock** your phone:

Press  > Settings > Security > Phone Lock > Lock Now.

To **automatically lock** your phone whenever you turn it off:

Press  > Settings > Security > Phone Lock > Automatic Lock > On.

**Note:** You can make emergency calls on a locked phone (see page 57). A locked phone still rings or vibrates for incoming calls or messages, **but you need to unlock it to answer.**





## customize

---

### ring style

Your phone rings and/or vibrates to notify you of an incoming call, message, or other event. This ring and/or vibration is called an alert. You can select one of six different alert profiles: **Loud Ring**, **Soft Ring**, **Vibrate**, **Vibrate & Ring**, **Vibrate then Ring**, and **Silent**.

 = Loud

 = Vibrate

 = Soft

 = Silent

 = Vibe then Ring

 = Vibrate and Ring

The ring style profile's indicator displays at the top of your home screen. To choose your profile:

**Find it:** Press  > Ring Style > Style > *style name*

### change alerts in a ring style

You can change the alerts for incoming calls and other events. Your changes are saved in the current ring style profile.

**Find it:** Press  > Settings > Ring Styles > Details > *desired event* > Change > *alert for event*

### time & date

To set the time and date for your phone:

**Find it:** Press  > **Settings** > **Initial Setup** > **Time and Date**

**Note:** To choose an analog or digital clock for your home screen, press  > **Personalize** > **Home Screen** > **Clock Set**.

## wallpaper

You can set a photo, picture, or animation as a wallpaper (background) image in your home screen.

**Find it:** Press  > **Personalize** > **Wallpaper**

option	
<b>Set Layout</b>	Select <b>Center</b> to center the image in the display, <b>Tile</b> to repeat the image across the display, <b>Fit-to-Screen</b> to fit the picture into display size.
<b>Picture</b>	Select an image for your wallpaper image.

## screen saver

You can set a photo, picture, or animation as a screen saver image. The screen saver displays when no activity is detected for a specified time.

**Tip:** This feature helps save your screen but not your battery. To extend battery life, turn off the screen saver.

**Find it:** Press  > **Personalize** > **Screen Saver**

## display appearance

To choose the **colors** that your phone uses for indicators, highlights, and soft key labels: Press  > **Personalize** > **Color Setting**.

To set your display **contrast**:  
Press  > **Settings** > **Initial Setup** > **Contrast**.

To set your display **Color** setting:  
Press  > **Personalize** > **Color Setting**.

To save battery life, the **backlight** turns off when you are not using your phone. The backlight turns back on when you press any key. To set how long your phone waits before the backlight turns off:

Press  > **Settings** > **Initial Setup** > **Backlight**.

## answer options

You can use additional, alternative methods to answer an incoming call. To activate or deactivate an answer option:

**Find it:** Press  > **Settings** > **In Call Setup** > **Answer Options**

option	
<b>Multi-key On</b>	Answer by pressing any key.
<b>Multi-key Off</b>	Answer by pressing  .

## personal greetings

You can create personal greetings that display when you turn on the phone:

**Find it:** Press  > Personalize > Greeting

## optional handsfree operation

A phone headset enables you to use your phone without using your hands.

**Note:** The use of wireless devices and their accessories may be prohibited or restricted in certain areas. Always obey the laws and regulations on the use of these products.

**Find it:** Press  > Settings > Headset > Auto Answer  
> *desired mode*

# calls

---

This chapter describes features related to making and answering calls.

## recent calls

Your phone keeps lists of incoming and outgoing calls, even for calls that did not connect. The most recent calls are listed first. The oldest calls are deleted as new calls are added.

**Shortcut:** Press **[☎]** from the home screen to see the **Dialed Calls** list.



**Find it:** Press **[☰]** > **Recent Calls**

- 1** Highlight **Received Calls** or **Dialed Calls**, then press the **SELECT** key.
- 2** Highlight a call. A ✓ next to a call means the call connected.
  - To call the number, press **[☎]**.
  - To see call details (like time and date), press the **VIEW** key.
  - To see the **Dialed Calls** list, press **[☰]**. This menu can include:

option	
<b>Store</b>	Create a phonebook entry with the number in the <b>No.</b> field.
<b>Delete</b>	Delete the entry.
<b>Delete All</b>	Delete all entries in the list.

option	
Hide ID	Hide your caller ID for the next call.
Send Message	Deliver the message.
Add Digits	Add digits after the number.
Attach Number	Attach a number from the phonebook or recent calls lists.

## redial

1 Press  from the home screen to see the **Dialed Calls** list. Or press  > **Recent Calls** > **Received Calls, Dialed Calls,**  or **NotePad**.

2 Highlight the entry you want to call, then press .

If you hear a busy signal and you see **Call Failed, Number Busy,** press  to redial the number.

## return a call

Your phone keeps a record of your unanswered calls and displays **X Missed Calls**, where **X** is the number of missed calls.

1 Press the **VIEW** key to see the **Received Calls** list.

2 Highlight the call you want to return, then press .

## notepad

Your phone stores the most recent string of digits entered on the keypad in a temporary memory location called the *notepad*. These digits can be the last phone number that you called, or a phone number that you simply entered but did

not call. These digits remain in the notepad even when you turn off the phone.

To call the number, create a phonebook entry, or perform other operations with the number stored in the notepad:

**Find it:** Press  > **Recent Calls** > **Notepad**



## hold or mute a call

When you are on a call:

Press  > **Hold** to put all active calls on hold.

Press  > **Mute** to put all active calls on mute.

## call waiting

When you're using your phone, you will hear an alert if you receive a second call. Press  to answer the new call. 

- To switch between calls, press the **SWITCH** key.
- To connect the two calls, press the **LINK** key.
- To end the call on hold, press  > **End Call On Hold**.

To turn the call waiting feature on or off:

**Find it:** Press  > **Settings** > **In Call Setup** > **Call Waiting**

## caller ID

*Calling line identification* (caller ID) shows the phone number for an incoming call in your external and internal displays.



Your phone shows the caller's name and picture when they're stored in your phonebook, or **Incoming Call** when caller ID information isn't available.

To show or hide **your phone number** for the next outgoing call or for all calls:

**Find it:** Press  > **Settings** > **In Call Setup** > **My Caller ID**

## emergency calls

Your service provider programs one or more emergency phone numbers (such as 911) that you can call under any circumstances, even when your phone is locked or the SIM card is not inserted. You can dial and call the emergency number even when your phone is locked, when you are prompted to enter a code or password.

**Note:** Emergency numbers vary by country. The preprogrammed emergency number(s) in your phone may not work in all locations. Sometimes an emergency call cannot be placed due to network, environmental, or interference issues.

To call the emergency number at any time:

- 1 Press the keypad keys to dial the emergency number.
- 2 Press  to call the emergency number.



## international calls

If your phone service includes international dialing, press and hold **0** to insert your local international access code (indicated by +). Then, press the keypad keys to dial the country code, such as +**4 4** for the U.K., +**3 3** for France, etc., and phone number. 

## 1-Touch dial

To call phonebook entries 1 through 9, press and hold the 1-Touch Dial number for one second.

You can set 1-Touch Dial to call the entries in your phone's memory phonebook, your SIM card's phonebook, or your **Fixed Dial** list:

**Find it:** Press  > **Settings** > **Initial Setup** > **1 Touch Dial** > **Phone, SIM,** or **Fixed Dial**

You can call phonebook entries 1 through 9 with the push of a single key. The first nine numbers from the SIM card would be placed in the 1-Touch Dial locations of 1 through 9.

Press and hold the 1-Touch Dial number for 1 second.

**Note:** To change 1-Touch Dial numbers, go to **Phonebook** to change the **Speed No.**

**Find it:** Press  > **Phonebook**, highlight a phone entry, then  > **Edit** > **Speed No.**

## voicemail

You can listen to your voicemail messages by calling your network voicemail phone number. Voicemail messages are stored on the network – not on your phone. Contact your service provider for more details. 

To store your voicemail number in your phone:

**Find it:** Press  > **Messages** >  > **Voicemail Setup**

When you receive a voicemail message, your phone displays **1 New Message** and a new voicemail indicator on the status pane. (Some networks only indicate when you have messages, whether they are new or not.) If users delete all voicemail messages, the voicemail indicator will disappear.

To listen to your voicemail messages:

**Find it:** Press  > **Messages** > **Voicemail**

Your phone may prompt you to store your voicemail phone number. If you do not have a voicemail number stored, the phone guides you through storing a number.

## inserting special characters into dialing sequences

You can insert special characters, as well as numbers, in a phone number.













<b>option</b>	
<b>p</b> (pause)	Your phone waits until the call connects before it dials the next digit(s) in the series.
<b>w</b> (wait)	Your phone waits until the call connects, then prompts you for confirmation before it dials the next digit(s).









You can add a pause or a wait while your call is dialing. To add a pause before the phone connects, press and hold **#**. When **p** appears, press it to add a pause. Or, if you are adding a wait, do not press **p**. The **w** will eventually appear and, when it does, press it to add a wait.

## other features



---

### advanced calling







feature	
<b>conference call</b>	After your first participant is connected, dial the next number, press  and then press the <b>LINK</b> key. 
<b>attach a phone number</b>	Dial an area code or prefix for a phonebook number, press  > <b>Attach Number</b> 
<b>speed dial</b>	Speed dial a phonebook entry: Enter a speed dial number, press  and then  . <b>Tip:</b> If you forget the speed dial number for a phonebook's entry, press  > <b>Phonebook</b> , highlight the desired entry, and press the <b>VIEW</b> key. 
<b>call forwarding</b>	Set up or cancel call forwarding:  > <b>Settings</b> > <b>Call Forward</b> 
<b>call barring</b>	Restrict outgoing or incoming calls:  > <b>Settings</b> > <b>Security</b> > <b>Call Barring</b> 

feature	
<b>change phone line</b>	<p>If you have a SIM card for dual phone lines, you can change your line to make and receive calls from your other phone number. </p> <p> &gt; <b>Settings</b> &gt; <b>Phone Status</b> &gt; <b>Active Line</b></p> <p>The active line indicator shows which phone line is active (see page 22).</p>
<b>fixed dial</b>	<p>When you turn on fixed dialing, you can call only numbers stored in the fixed dial list. </p> <p>Turn fixed dialing on or off:</p> <p> &gt; <b>Settings</b> &gt; <b>Security</b> &gt; <b>Fixed Dial</b></p> <p>Use the fixed dial list:</p> <p> &gt; <b>Office Tools</b> &gt; <b>Dialing Services</b> &gt; <b>Fixed Dial</b></p>
<b>quick dial</b>	<p>Dial preprogrammed phone numbers: </p> <p> &gt; <b>Office Tools</b> &gt; <b>Dialing Services</b> &gt; <b>Quick Dial</b></p>
<b>DTMF tones</b>	<p>Set to <b>Long DTMF</b> or <b>Short DTMF</b>:</p> <p> &gt; <b>Settings</b> &gt; <b>Initial Setup</b> &gt; <b>DTMF</b></p>

## phonebook

feature	
<b>add new entry</b>	<p>If you store your entry onto the SIM card, the phone number is together with SIM card. If you use a different SIM card you will see the same phone entry on the phone.</p> <p>If you store your entry onto the phone, the phone number is together with the phone. If you put the same SIM card into a different phone, you won't find the phone entry.</p> <p> &gt; Phonebook &gt;  &gt; New &gt; Number &gt; Store to</p> <p><b>Shortcut:</b> Enter a phone number in the home screen, then press the <b>STORE</b> key to create an entry for that number.</p> <p><b>Tip:</b> Some people have more than one phone number. When creating a phonebook entry, select More to store another number for the same <b>Name</b>.</p> <p><b>Note:</b> Phone's memory is 100 entries. The SIM capacity depends on the carrier's SIM card type, but at most 255 entries.</p>













feature	
<b>download ringtones</b>	<p>You can try this function by sending from one handset to another one:</p> <p>☰ &gt; Messages &gt; Create &gt; SMS/EMS or MMS or MMS Templates &gt; Insert &gt; Sound</p> <p>The ringtone download is through EMS or MMS. When you receive the EMS and MMS from another party, you can retrieve the ring tone from EMS or MMS message. You can also send the ring tone by sending EMS or MMS.</p>
<b>dial number</b>	<p>Call a number stored in the phonebook:</p> <p>☰ &gt; Phonebook, highlight the phonebook entry, press ☑.</p> <p><b>Shortcut:</b> In the phonebook, press a keypad key one or more times to jump to entries that begin with the letters on that key.</p>
<b>set category for entry</b>	<p>☰ &gt; Phonebook &gt; entry ☰ &gt; Category</p> <p>You can classify an entry into the following categories: <b>All, Business, Personal, General, VIPs</b>, or a category you create.</p>
<b>set category view</b>	<p>☰ &gt; Phonebook &gt; entry ☰ &gt; Category</p> <p>You can view <b>All</b> entries or those in the predefined category such as <b>Business, Personal, General, VIPs</b>, or a category you create.</p>













feature	
<b>search phonebook entry</b>	Press a keypad key 1 or more times to jump to entries that begin with the key's letters. Press a second letter to jump to entries beginning with the two letters you entered. You can enter up to three letters.   > <b>Phonebook</b>
<b>sort phonebook list</b>	Set the order in which entries are listed:  > <b>Phonebook</b> >  > <b>Setup</b> > <b>Sorting</b> > <i>sort order</i>
<b>copy phonebook entry</b>	Copy a phonebook entry to the SIM card, or from the SIM card to the phone:  > <b>Phonebook</b> , highlight the entry, press  > <b>Copy</b> > <b>Entries</b> > <b>To</b>
<b>copy multiple entries</b>	Copy multiple phonebook entries between the phone and SIM card:  > <b>Phonebook</b> , highlight one entry, press  > <b>Copy</b> > <b>Entries</b> , press the <b>CHANGE</b> key, highlight another entry, press the <b>ADD</b> key. Repeat as necessary, press the <b>DONE</b> key, > <b>To</b> .



## messages







For basic multimedia message features, see page 14.

feature		
<b>send text message</b>	 > Messages > Create > SMS/EMS	
<b>send multimedia message</b>	 > Messages > Create > MMS	
<b>send a quick note</b>	 > Messages > Quick Notes	
<b>send a multimedia template</b>	Open a multimedia template with preloaded media:  > Messages > Create > MMS Templates	
<b>read new message</b>	Read a new text or multimedia message: Press the <b>READ</b> key when the <b>New Message</b> notification displays.	
<b>read old messages</b>	Read old messages:  > Messages > Inbox Press  to perform various operations on a message.	







feature	
<b>send a multimedia template</b>	Open a multimedia template with preloaded media:   > <b>Messages</b> > <b>Create</b> > <b>MMS Templates</b>
<b>read new message</b>	Read a new text or multimedia message:  Press the <b>READ</b> key when the <b>New Message</b> notification displays.
<b>read old messages</b>	Read old messages:   > <b>Messages</b> > <b>Inbox</b> Press  to perform various operations on a message.
<b>read sent messages</b>	Read messages that you sent:   > <b>Messages</b> > <b>Outbox</b> Sent messages are saved in the <b>Outbox</b> .
<b>edit old draft</b>	Save the message that you are editing to the <b>Draft</b> box for later editing:  > <b>Messages</b> > <b>Draft</b>
<b>browser messages</b>	Read messages received by your browser:   > <b>Messages</b> > <b>Browser Msgs</b>
<b>info services</b>	Read messages from subscription-based services:   > <b>Messages</b> > <b>Info Services</b>

feature	
<b>sending and receiving vCard</b>	<p>You can send the vCard by sending MMS with attachment (vCard is the attachment). You also can receive vCard from anyother party throu MMS with attachment. You can save the received vCard by open MMS with vCard attachment. This function can be sent from one handset to another.</p> <p> &gt; Messages &gt; Create &gt; MMS or MMS Templates &gt; Insert &gt; vCard</p>







## instant messaging







feature	
<b>log in</b>	<p> &gt; Office Tools &gt; IM &gt; Log In </p>
<b>find others online</b>	<p>After you log in: Select <b>Contact List</b> to see a list of other users. </p>
<b>start conversation</b>	<p>From your <b>Contact List</b>, highlight a name in <b>Online Contacts</b>, press the <b>SEND IM</b> key. </p>
<b>open active conversation</b>	<p>From your <b>Contact list</b>, highlight a name in <b>Conversation</b>, press the <b>VIEW</b> key. </p>
<b>end conversation</b>	<p>From the conversation display:  &gt; End conversation </p>
<b>log out</b>	<p>Select <b>Log Out</b> from the <b>IM Online</b> menu.</p>

## chat

feature		
<b>start chat</b>	 > Office Tools > Chat  > New Chat 	
<b>receive chat request</b>	Press the <b>ACCEPT</b> key or the <b>IGNORE</b> key. 	
<b>end chat</b>	During a chat session:  > End Chat 	

## personalizing

feature	
<b>language</b>	Set menu language:  > Settings > Initial Setup > Language
<b>scroll</b>	Set the highlight bar to stop or wrap around in the menu lists:  > Settings > Initial Setup > Scroll
<b>ring volume</b>	 > Settings > Ring Styles > <i>style</i> Detail > Ring Volume
<b>keypad volume</b>	 > Settings > Ring Styles > <i>style</i> Detail > Key Volume
<b>clock view</b>	Display an analog or digital clock in the home screen:  > Personalize > Home Screen > Clock Set
<b>menu view</b>	Display the main menu as graphic icons or as a text-based list:  > Personalize > Main Menu > View









feature	
<b>main menu</b>	Reorder items in your phone's main menu:  > <b>Personalize</b> > <b>Main Menu</b> > <b>Reorder</b>
<b>show/hide menu icons</b>	Show or hide menu feature icons in the home screen:  > <b>Personalize</b> > <b>Home Screen</b> > <b>Home keys</b> > <b>Icons</b>
<b>change home keys</b>	Change the functions for the soft keys and navigation key in the home screen:  > <b>Personalize</b> > <b>Home Screen</b> > <b>Home keys</b>
<b>shortcuts</b>	Create a shortcut to a menu item: Highlight the menu item, then press and hold  . Use a shortcut: Press  , then press the shortcut number.
<b>master reset</b>	Reset all options <b>except</b> unlock code, security code, and lifetime timer:  > <b>Settings</b> > <b>Initial Setup</b> > <b>Master Reset</b> <b>Note:</b> Before the master reset, you need to input your security code.

feature	
<b>master clear</b>	<p>To reset all options to their factory settings and clear all user entries (such as downloaded wallpapers, main menu animation, and sounds):</p> <p><b>Warning:</b> This option erases all <b>information you have entered</b> (including phonebook entries) and <b>content you have downloaded</b>. Once you erase the information, it cannot be recovered. All options are reset back to their factory settings, <b>except</b> for the unlock code, security code, and lifetime timer.</p> <p><b>Find it:</b> Press  &gt; <b>Settings</b> &gt; <b>Initial Setup</b> &gt; <b>Master Clear</b></p> <p>To clear all information, you need to enter the <b>Security Code</b> (000000).</p>

## call times & costs



**Network connection time** is the elapsed time from the moment you connect to your service provider's network to the moment you end the call by pressing . This time includes busy signals and ringing.

**The amount of network connection time that you track on your resettable timer may not equal the amount of time for which you are billed by your service provider. For billing information, contact your service provider.**



feature	
<b>call times</b>	Display call timers:  > <b>Recent Calls</b> > <b>Call Times</b> 
<b>in-call timer</b>	Display time during a call:  > <b>Settings</b> > <b>In Call Setup</b> > <b>In-Call Timer</b> 
<b>call cost</b>	Display call cost trackers:  > <b>Recent calls</b> > <b>Call Cost</b> 
<b>call cost setup</b>	Set a credit limit:  > <b>Settings</b> > <b>In-Call Setup</b> > <b>Call Cost Setup</b> 

## handsfree operation





**Note:** The use of wireless devices and their accessories may be prohibited or restricted in certain areas. Always obey the laws and regulations on the use of these products.

feature	
<b>speakerphone</b>	Activate a connected external speakerphone during a call: Press the <b>H.FREE</b> key 
<b>auto answer</b>	Automatically answer calls when connected to a car kit or headset:  > <b>Settings</b> > <b>Headset</b> > <b>Auto Answer</b> 

## network

feature	
<b>network settings</b>	Display network information and adjust network settings:   > <b>Settings</b> > <b>Network</b>



## personal organizer

feature	
<b>set alarm</b>	 > <b>Office Tools</b> > <b>Alarm Clock</b>
<b>turn off alarm</b>	When an alarm displays: To turn off the alarm, press the <b>DISABLE</b> key. To set the alarm to ring later, press the <b>SNOOZE</b> key.
<b>calculator</b>	 > <b>Office Tools</b> > <b>Calculator</b>
<b>currency converter</b>	 > <b>Office Tools</b> > <b>Calculator</b>  > <b>Exchange Rate</b> Enter exchange rate, press the <b>OK</b> key, enter amount, and select  > <b>Convert Currency</b> .









feature	
stop watch	 > Office Tools > Stop Watch <p>Press the <b>START</b> key to start counting the time, the <b>STOP</b> key to stop counting the time, and press <b>RESET</b> to reset the stopwatch.</p> <p><b>Note:</b> After <b>Stop Watch</b> is activated, you may press <b>SNAPSHOT</b> to keep track of the time elapse you would like to refer to for later use. After stopping the <b>Stop Watch</b>, press the <b>Right</b> or <b>Left</b> keys to navigate through the <b>SNAPSHOT</b> time 1, 2, 3, and further.</p>

## security

feature	
<b>SIM PIN</b>	Lock or unlock the SIM card:  > <b>Settings</b> > <b>Security</b> > <b>SIM PIN</b> <b>Caution:</b> If you enter an incorrect PIN code 3 times in a row, your SIM card is disabled and your phone displays <b>SIM Blocked</b> .
<b>phone lock</b>	 > <b>Settings</b> > <b>Security</b> > <b>Phone Lock</b> Select to lock the phone right now or enable/disable the Automatic Lock.

## fun & games

feature	
<b>manage pictures</b>	Manage pictures and animations:   > <b>Multimedia</b> > <b>Pictures</b>
<b>manage sounds</b>	Manage ring tones and music that you have downloaded or composed:  > <b>Multimedia</b> > <b>Sounds</b>
<b>start browser</b>	 > <b>Web Access</b> > <b>Start Browser</b> 
<b>start games</b>	 > <b>Games &amp; Apps</b> > <i>game</i> 

## service and repairs

---

### check here first

If your phone does not seem to work properly, look here first. If you still need help, see “service and repairs” on page 58.

### changing the time on the phone’s clock

**Question:** My phone’s clock is incorrect during normal use. How can I change it?

**Answer:** The phone’s system clock is reset whenever you remove the battery. This will cause the clock to display the incorrect time the next time you turn on the phone’s power.

Whenever you replace the battery and turn on the phone’s power, be sure to enter the correct time and date:

**Find it:** Press  > Settings > Initial Setup > Time and Date

### using the Send/End key on the headset

**Question:** When I use the headset with my phone, nothing happens when I press the **Send/End** key on the headset. Why?

**Answer:** The phone does not support the **Send/End** key function on the headset.

## no incoming call ring tone

**Question:** Why don't I hear a ring tone for incoming calls or messages?

**Answer:** The volume may be set to level 0 (silent).

Check if your ring style setting is **Silent**:

**Find it:** Press  > **Settings** > **Ring Style** > **Style**

Or, check if the ring volume is set to level 0:

**Find it:** Press  > **Settings** > **Ring Style** > **Ring Style detail** > **Ring Volume**

## no service

**Question:** When I turn on my phone for the first time, or when I turn it on while traveling to another country, my phone displays **No Service**. Why?

**Answer:** Each operator has its own operation frequency band. Make sure your phone's band selection setting matches the operator's frequency band:

**Find it:** Press  > **Settings** > **Network** > **Band Selection**

## service and repairs

If you have questions or need assistance, we're here to help.

Go to [www.motorola.com/consumer/support](http://www.motorola.com/consumer/support), where you can select from a number of customer care options. You can also contact the Motorola Customer Support Center at 1-800-331-6456 (United States), 1-888-390-6456 (TTY/TDD United States for hearing impaired), or 1-800-461-4575 (Canada).

## Specific Absorption Rate Data

---

### The model wireless phone meets the government's requirements for exposure to radio waves.

Your wireless phone is a radio transmitter and receiver. It is designed and manufactured not to exceed limits for exposure to radio frequency (RF) energy set by the Federal Communications Commission (FCC) of the U.S. Government and by the Canadian regulatory authorities. These limits are part of comprehensive guidelines and establish permitted levels of RF energy for the general population. The guidelines are based on standards that were developed by independent scientific organizations through periodic and thorough evaluation of scientific studies. The standards include a substantial safety margin designed to assure the safety of all persons, regardless of age or health.

The exposure standard for wireless mobile phones employs a unit of measurement known as the Specific Absorption Rate, or SAR. The SAR limit set by the FCC and by the Canadian regulatory authorities is 1.6 W/kg.<sup>1</sup> Tests for SAR are conducted using standard operating positions accepted by the FCC and by Industry Canada with the phone transmitting at its highest certified power level in all tested frequency bands. Although the SAR is determined at the highest certified power level, the actual SAR level of the phone while operating can be well below the maximum value. This is because the phone is designed to operate at multiple power levels so as to use only the power required to reach the network. In general, the closer you are to a wireless base station, the lower the power output.

Before a phone model is available for sale to the public in the U.S. and Canada, it must be tested and certified to the FCC and Industry Canada that it does not exceed the limit established by each government for safe exposure. The tests are performed in positions and locations (e.g., at the ear and worn on the body) reported to the FCC and available for review by Industry Canada. The highest SAR value for this model phone when tested for use at the ear is 1.38W/kg, and when worn on the body, as described in

this user guide, is 0.66 W/kg. (Body-worn measurements differ among phone models, depending upon available accessories and regulatory requirements).<sup>2</sup>

While there may be differences between the SAR levels of various phones and at various positions, they all meet the governmental requirements for safe exposure. Please note that improvements to this product model could cause differences in the SAR value for later products; in all cases, products are designed to be within the guidelines.

Additional information on Specific Absorption Rates (SAR) can be found on the Cellular Telecommunications & Internet Association (CTIA) Web site:

<http://www.phonefacts.net>

or the Canadian Wireless Telecommunications Association (CWTA) Web site:

<http://www.cwta.ca>

1. In the United States and Canada, the SAR limit for mobile phones used by the public is 1.6 watts/kg (W/kg) averaged over one gram of tissue. The standard incorporates a substantial margin of safety to give additional protection for the public and to account for any variations in measurements.
2. The SAR information includes the Motorola testing protocol, assessment procedure, and measurement uncertainty range for this product.

## Specific Absorption Rate Data

---

### The model wireless phone meets the government's requirements for exposure to radio waves.

Your wireless phone is a radio transmitter and receiver. It is designed and manufactured not to exceed limits for exposure to radio frequency (RF) energy set by the Federal Communications Commission (FCC) of the U.S. Government and by the Canadian regulatory authorities. These limits are part of comprehensive guidelines and establish permitted levels of RF energy for the general population. The guidelines are based on standards that were developed by independent scientific organizations through periodic and thorough evaluation of scientific studies. The standards include a substantial safety margin designed to assure the safety of all persons, regardless of age or health.

The exposure standard for wireless mobile phones employs a unit of measurement known as the Specific Absorption Rate, or SAR. The SAR limit set by the FCC and by the Canadian regulatory authorities is 1.6 W/kg.<sup>1</sup> Tests for SAR are conducted using standard operating positions accepted by the FCC and by Industry Canada with the phone transmitting at its highest certified power level in all tested frequency bands. Although the SAR is determined at the highest certified power level, the actual SAR level of the phone while operating can be well below the maximum value. This is because the phone is designed to operate at multiple power levels so as to use only the power required to reach the network. In general, the closer you are to a wireless base station, the lower the power output.

Before a phone model is available for sale to the public in the U.S. and Canada, it must be tested and certified to the FCC and Industry Canada that it does not exceed the limit established by each government for safe exposure. The tests are performed in positions and locations (e.g., at the ear and worn on the body) reported to the FCC and available for review by Industry Canada. The highest SAR value for this model phone when tested for use at the ear is , **1.38 W/kg** and when worn on the body, as described in this

user guide, is . **0.66 W/kg** The SAR value for this product in its data transmission mode (body-worn use) is W/kg. (Body-worn measurements differ among phone models, depending upon available accessories and regulatory requirements).<sup>2</sup>

While there may be differences between the SAR levels of various phones and at various positions, they all meet the governmental requirements for safe exposure. Please note that improvements to this product model could cause differences in the SAR value for later products; in all cases, products are designed to be within the guidelines.

Additional information on Specific Absorption Rates (SAR) can be found on the Cellular Telecommunications & Internet Association (CTIA) Web site:

<http://www.phonefacts.net>

or the Canadian Wireless Telecommunications Association (CWTA) Web site:

<http://www.cwta.ca>

3. In the United States and Canada, the SAR limit for mobile phones used by the public is 1.6 watts/kg (W/kg) averaged over one gram of tissue. The standard incorporates a substantial margin of safety to give additional protection for the public and to account for any variations in measurements.
4. The SAR information includes the Motorola testing protocol, assessment procedure, and measurement uncertainty range for this product.