



# FCC RF Test Report

**APPLICANT** : Motorola Mobility LLC  
**EQUIPMENT** : Mobile Cellular Phone  
**BRAND NAME** : Motorola  
**MODEL NAME** : 9369, 9847  
**FCC ID** : IHDT56VF2  
**STANDARD** : FCC Part 15 Subpart C §15.247  
**CLASSIFICATION** : (DTS) Digital Transmission System

The product was received on Sep. 30, 2016 and testing was completed on Oct. 17, 2016. We, SPORTON INTERNATIONAL (KUNSHAN) INC., would like to declare that the tested sample has been evaluated in accordance with the test procedures and has been in compliance with the applicable technical standards.

The test results in this report apply exclusively to the tested model / sample. Without written approval of SPORTON INTERNATIONAL (KUNSHAN) INC., the test report shall not be reproduced except in full.

Prepared by: James Huang / Manager



Approved by: Jones Tsai / Manager

**SPORTON INTERNATIONAL (KUNSHAN) INC.**  
**No. 3-2, PingXiang Road, Kunshan, Jiangsu Province, P. R. China**



# TABLE OF CONTENTS

**REVISION HISTORY..... 3**

**SUMMARY OF TEST RESULT ..... 4**

**1 GENERAL DESCRIPTION ..... 5**

    1.1 Applicant ..... 5

    1.2 Manufacturer ..... 5

    1.3 Product Feature of Equipment Under Test..... 5

    1.4 Product Specification of Equipment Under Test..... 6

    1.5 Specification of Accessory ..... 6

    1.6 Modification of EUT ..... 6

    1.7 Testing Location ..... 6

    1.8 Applicable Standards..... 7

**2 TEST CONFIGURATION OF EQUIPMENT UNDER TEST ..... 8**

    2.1 Carrier Frequency and Channel ..... 8

    2.2 Pre-Scanned RF Power ..... 9

    2.3 Test Mode ..... 10

    2.4 Connection Diagram of Test System..... 11

    2.5 Support Unit used in test configuration and system ..... 13

    2.6 EUT Operation Test Setup ..... 13

    2.7 Measurement Results Explanation Example..... 13

**3 TEST RESULT ..... 14**

    3.1 6dB and 99% Bandwidth Measurement ..... 14

    3.2 Output Power Measurement..... 16

    3.3 Power Spectral Density Measurement ..... 18

    3.4 Conducted Band Edges and Spurious Emission Measurement ..... 20

    3.5 Radiated Band Edges and Spurious Emission Measurement ..... 30

    3.6 AC Conducted Emission Measurement..... 34

    3.7 Antenna Requirements ..... 38

**4 LIST OF MEASURING EQUIPMENT ..... 39**

**5 UNCERTAINTY OF EVALUATION ..... 40**

**APPENDIX A. CONDUCTED TEST RESULTS**

**APPENDIX B. RADIATED SPURIOUS EMISSION**

**APPENDIX C. DUTY CYCLE PLOTS**

**APPENDIX D. SETUP PHOTOGRAPHS**





### SUMMARY OF TEST RESULT

Report Section	FCC Rule	Description	Limit	Result	Remark
3.1	15.247(a)(2)	6dB Bandwidth	$\geq 0.5\text{MHz}$	Pass	-
3.1	-	99% Bandwidth	-	Pass	-
3.2	15.247(b)	Power Output Measurement	$\leq 30\text{dBm}$	Pass	-
3.3	15.247(e)	Power Spectral Density	$\leq 8\text{dBm}/3\text{kHz}$	Pass	-
3.4	15.247(d)	Conducted Band Edges	$\leq 20\text{dBc}$	Pass	-
		Conducted Spurious Emission		Pass	-
3.5	15.247(d)	Radiated Band Edges and Radiated Spurious Emission	15.209(a) & 15.247(d)	Pass	Under limit 3.04 dB at 2483.560 MHz
3.6	15.207	AC Conducted Emission	15.207(a)	Pass	Under limit 10.08 dB at 0.521 MHz
3.7	15.203 & 15.247(b)	Antenna Requirement	N/A	Pass	-



# 1 General Description

## 1.1 Applicant

Motorola Mobility LLC  
222 W, Merchandise Mart Plaza, Chicago IL 60654 USA

## 1.2 Manufacturer

Motorola Mobility LLC  
222 W, Merchandise Mart Plaza, Chicago IL 60654 USA

## 1.3 Product Feature of Equipment Under Test

Product Feature	
Equipment	Mobile Cellular Phone
Brand Name	Motorola
Model Name	9369, 9847
FCC ID	IHDT56VF2
EUT supports Radios application	GSM/GPRS/EGPRS/WCDMA/HSPA/DC-HSDPA/ HSPA+(16QAM uplink is not supported)/LTE/ WLAN 2.4GHz 802.11b/g/n HT20/ WLAN 5GHz 802.11a/n HT20/HT40/ Bluetooth v3.0 + EDR/Bluetooth v4.0 LE/ Bluetooth v4.2 LE
IMEI Code	Conducted: 351864080029279/351864080029287 Radiation: 351864080029311/351864080029329 Conduction: 351864080029238/351864080029246
HW Version	DVT2(V5.0)
SW Version	cedric-userdebug 7.0 NPP25.73 270 intcfg,test-keys
EUT Stage	Production Unit

**Remark:**

1. The above EUT's information was declared by manufacturer. Please refer to the specifications or user's manual for more detailed description.
2. There are two types of EUT sample 1 and sample 2, the differences between two samples are only for SIM slot, sample 1(Model name: 9369) is dual SIM slot, sample 2(Model name: 9847) is single SIM slot. According to the difference, the sample 1 to perform full test.



### 1.4 Product Specification of Equipment Under Test

Standards-related Product Specification	
<b>Tx/Rx Channel Frequency Range</b>	2412 MHz ~ 2462 MHz
<b>Maximum (Peak) Output Power to antenna</b>	802.11b : 20.22 dBm (0.1052 W) 802.11g : 20.82 dBm (0.1208 W) 802.11n HT20 : 19.51 dBm (0.0893 W)
<b>99% Occupied Bandwidth</b>	802.11b : 13.74MHz 802.11g : 18.68MHz 802.11n HT20 : 19.48MHz
<b>Antenna Type / Gain</b>	PIFA Antenna with gain -1.55 dBi
<b>Type of Modulation</b>	802.11b : DSSS (DBPSK / DQPSK / CCK) 802.11g/n : OFDM (BPSK / QPSK / 16QAM / 64QAM)

### 1.5 Specification of Accessory

Specification of Accessory				
<b>AC Adapter</b>	<b>Brand Name</b>	Motorola (Acbel)	<b>Model Name</b>	C-P35
	<b>Power Rating</b>	I/P: 100-240 Vac, 300mA, O/P: 5.2Vdc, 2000mA		
<b>Battery</b>	<b>Brand Name</b>	Motorola (ATL)	<b>Model Name</b>	GK40
	<b>Power Rating</b>	3.8Vdc, 2685/2800mAh (Min/Typ)	<b>Type</b>	Li-ion
<b>Earphone</b>	<b>Brand Name</b>	Motorola	<b>Model Name</b>	SJYN1181B
	<b>Signal Line Type</b>	1.2 meter, non-shielded cable, without ferrite core		
<b>USB Cable</b>	<b>Brand Name</b>	Motorola (Liqi)	<b>Model Name</b>	L25W-051000100AL
	<b>Signal Line Type</b>	1.0 meter, non-shielded cable, without ferrite core		

### 1.6 Modification of EUT

No modifications are made to the EUT during all test items.

### 1.7 Testing Location

<b>Test Site</b>	SPORTON INTERNATIONAL (KUNSHAN) INC.			
<b>Test Site Location</b>	No. 3-2, PingXiang Road, Kunshan, Jiangsu Province, P. R. China			
	TEL: +86-0512-5790-0158			
	FAX: +86-0512-5790-0958			
<b>Test Site No.</b>	<b>Sporton Site No.</b>			<b>FCC Registration No.</b>
	TH01-KS	03CH03-KS	CO01-KS	306251

**Note:** The test site complies with ANSI C63.4 2014 requirement.



## 1.8 Applicable Standards

According to the specifications of the manufacturer, the EUT must comply with the requirements of the following standards:

- ♦ FCC Part 15 Subpart C §15.247
- ♦ FCC KDB Publication No. 558074 D01 DTS Meas. Guidance v03r05
- ♦ ANSI C63.10-2013

**Remark:**

1. All test items were verified and recorded according to the standards and without any deviation during the test.
2. This EUT has also been tested and complied with the requirements of FCC Part 15, Subpart B, recorded in a separate test report.



## 2 Test Configuration of Equipment Under Test

The EUT has been associated with peripherals and configuration operated in a manner tended to maximize its emission characteristics in a typical application. Frequency range investigated: conducted emission (150 kHz to 30 MHz) and radiated emission (9 kHz to the 10th harmonic of the highest fundamental frequency or to 40 GHz, whichever is lower). For radiated measurement, pre-scanned in three orthogonal panels, X, Y, Z. The worst cases were recorded in this report.

### 2.1 Carrier Frequency and Channel

Frequency Band	Channel	Freq. (MHz)	Channel	Freq. (MHz)
2400-2483.5 MHz	1	2412	7	2442
	2	2417	8	2447
	3	2422	9	2452
	4	2427	10	2457
	5	2432	11	2462
	6	2437	-	-





## 2.2 Pre-Scanned RF Power

Preliminary tests were performed in different data rate and data rate associated with the highest power were chosen for full test shown in the following tables.

802.11b mode Peak Power (dBm)					
Channel	Freq. (MHz)	Data Rate (MHz)			
		1M bps	2M bps	5.5M bps	11M bps
CH 01	2412 MHz	19.02	19.00	18.95	18.99
CH 06	2437 MHz	20.22	20.16	20.18	20.20
CH 11	2462 MHz	19.66	19.59	19.65	19.57

802.11g mode Peak Power (dBm)									
Channel	Freq. (MHz)	Data Rate (MHz)							
		6M bps	9M bps	12M bps	18M bps	24M bps	36M bps	48M bps	54M bps
CH 01	2412 MHz	19.92	19.90	19.82	19.86	19.91	19.85	19.89	19.88
CH 06	2437 MHz	20.82	20.78	20.80	20.77	20.67	20.75	20.76	20.69
CH 11	2462 MHz	20.43	20.38	20.36	20.35	20.42	20.40	20.37	20.32

802.11n HT20 mode Peak Power (dBm)									
Channel	Freq. (MHz)	Data Rate (MHz)							
		MCS0	MCS1	MCS2	MCS3	MCS4	MCS5	MCS6	MCS7
CH 01	2412 MHz	19.42	19.39	19.38	19.35	19.40	19.34	19.41	19.31
CH 06	2437 MHz	19.51	19.45	19.38	19.37	19.39	19.46	19.50	19.48
CH 11	2462 MHz	18.33	18.31	18.24	18.26	18.18	18.20	18.27	18.30



### 2.3 Test Mode

Final test mode of conducted test items and radiated spurious emissions are considering the modulation and worse data rates from the power table described in section 2.2.

Modulation	Data Rate
802.11b	1 Mbps
802.11g	6 Mbps
802.11n HT20	MCS0

Test Cases	
AC Conducted	Mode 1 : GSM850 Idle + Bluetooth Link + WLAN (2.4G) Link + USB Cable (Charging from Adapter) +
Emission	Earphone

## 2.4 Connection Diagram of Test System

<WLAN b/g Tx Mode>

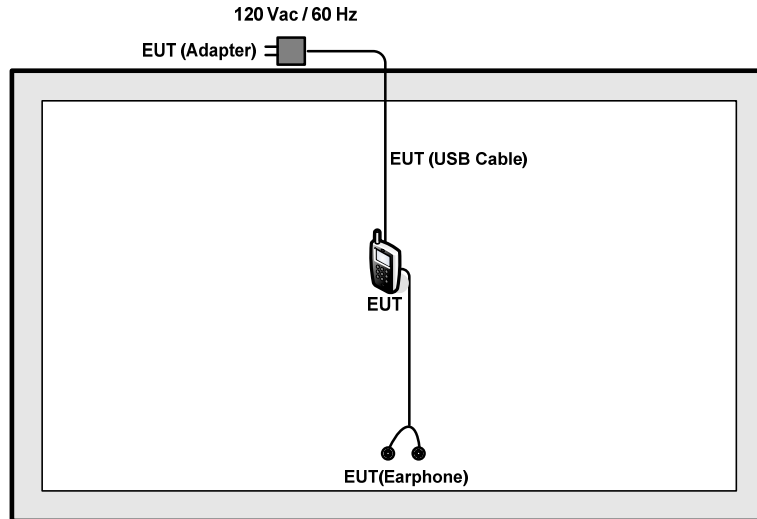

<WLAN 11n(HT20) Tx Mode>

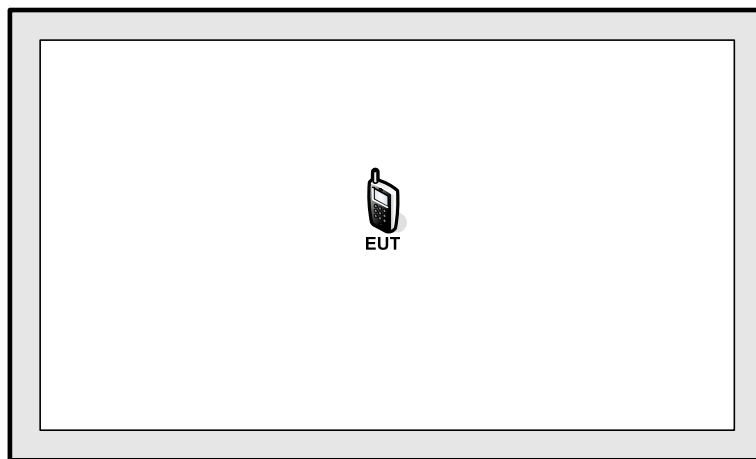

<AC Conducted Emission Mode>

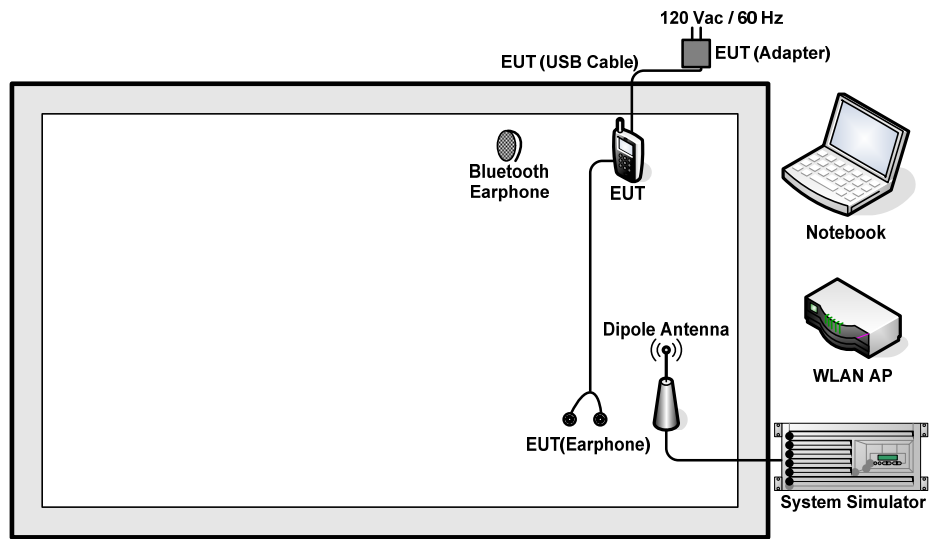

## 2.5 Support Unit used in test configuration and system

Item	Equipment	Trade Name	Model Name	FCC ID	Data Cable	Power Cord
1.	System Simulator	Anritsu	MT8820C	N/A	N/A	Unshielded, 1.8 m
2.	WLAN AP	Linksys	WRT600N	Q87-WRT600NV11	N/A	Unshielded, 1.8 m
3.	Notebook	Lenovo	G480	FCC DoC	N/A	Shielded cable DC O/P 1.8 m Unshielded AC I/P cable 1.2 m
4.	Bluetooth Earphone	Lenovo	LBH308	N/A	N/A	N/A

## 2.6 EUT Operation Test Setup

For WLAN function, the engineering test program was provided and enabled to make EUT continuous transmit/receive.

For AC power line conducted emissions, the EUT was set to connect with the Notebook under large package sizes transmission.

## 2.7 Measurement Results Explanation Example

**For all conducted test items:**

The offset level is set in the spectrum analyzer to compensate the RF cable loss between EUT conducted output port and spectrum analyzer. With the offset compensation, the spectrum analyzer reading level is exactly the EUT RF output level.

Example :

The spectrum analyzer offset is derived from RF cable loss.

*Offset = RF cable loss.*

Following shows an offset computation example with cable loss 5.8 dB.

*Offset(dB) = RF cable loss(dB).*

*= 5.8 (dB)*

### 3 Test Result

#### 3.1 6dB and 99% Bandwidth Measurement

##### 3.1.1 Limit of 6dB and 99% Bandwidth

The minimum 6 dB bandwidth shall be at least 500 kHz.

##### 3.1.2 Measuring Instruments

The measuring equipment is listed in the section 4 of this test report.

##### 3.1.3 Test Procedures

1. The testing follows FCC KDB Publication No. 558074 DTS D01 Meas. Guidance v03r05.
2. The RF output of EUT was connected to the spectrum analyzer by RF cable and attenuator. The path loss was compensated to the results for each measurement.
3. Set to the maximum power setting and enable the EUT transmit continuously.
4. Make the measurement with the spectrum analyzer's resolution bandwidth (RBW) = 100 kHz. Set the Video bandwidth (VBW) = 300 kHz. In order to make an accurate measurement. The 6 dB bandwidth must be greater than 500 kHz.
5. For 99% Bandwidth Measurement, the spectrum analyzer's resolution bandwidth (RBW) = 1MHz and set the Video bandwidth (VBW) = 3MHz.
6. Measure and record the results in the test report.

##### 3.1.4 Test Setup





### 3.1.5 Test Result of 6dB and 99% Occupied Bandwidth

Please refer to Appendix A.

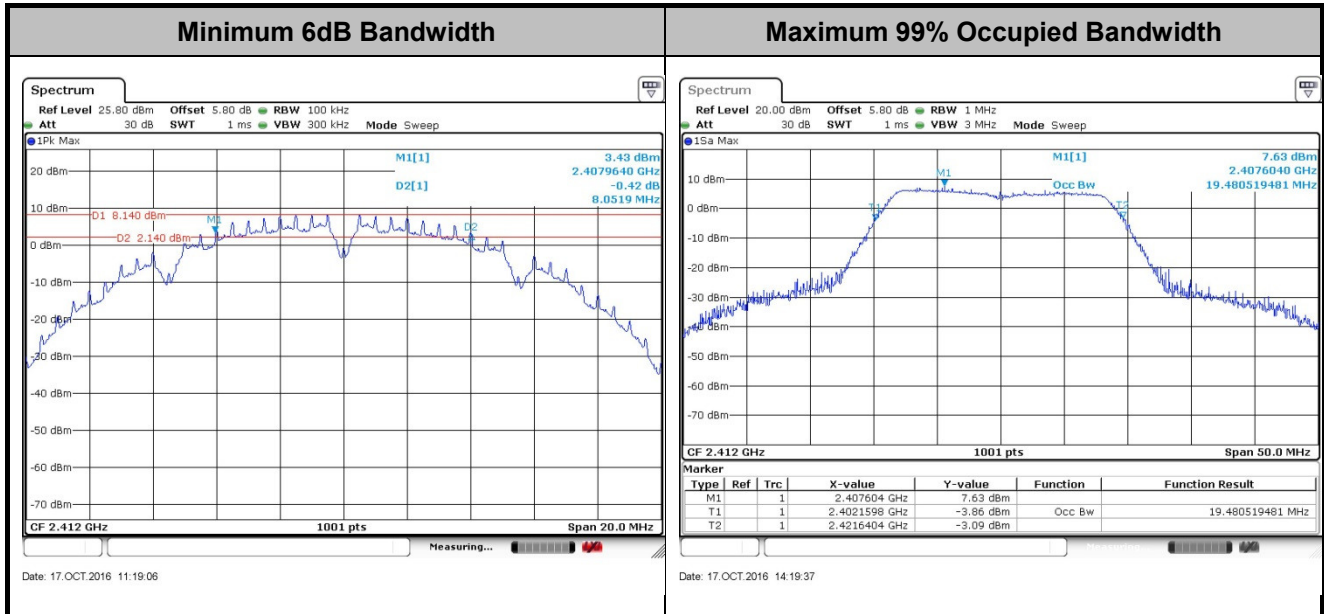

Note : The occupied channel bandwidth is maintained within the band of operation for all of the modulations.

## 3.2 Output Power Measurement

### 3.2.1 Limit of Output Power

For systems using digital modulation in the 2400-2483.5MHz, the limit for peak output power is 30dBm. If transmitting antenna of directional gain greater than 6dBi are used the peak output power from the intentional radiator shall be reduced below the above stated value by the amount in dB that the directional gain of the antenna exceeds 6 dBi. In case of point-to-point operation, the limit has to be reduced by 1dB for every 3dB that the directional gain of the antenna exceeds 6dBi.

### 3.2.2 Measuring Instruments

The measuring equipment is listed in the section 4 of this test report.

### 3.2.3 Test Procedures

1. The testing follows the Measurement Procedure of FCC KDB No. 558074 DTS D01 Meas. Guidance v03r05 section 9.1.2 PKPM1 Peak power meter method.
2. The RF output of EUT was connected to the power meter by RF cable and attenuator. The path loss was compensated to the results for each measurement.
3. Set to the maximum power setting and enable the EUT transmit continuously.
4. Measure the conducted output power and record the results in the test report.

### 3.2.4 Test Setup

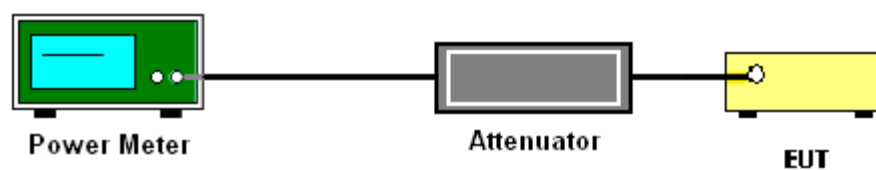





### **3.2.5 Test Result of Peak Output Power**

Please refer to Appendix A.

### **3.2.6 Test Result of Average output Power (Reporting Only)**

Please refer to Appendix A.

### 3.3 Power Spectral Density Measurement

#### 3.3.1 Limit of Power Spectral Density

The peak power spectral density shall not be greater than 8dBm in any 3kHz band at any time interval of continuous transmission.

#### 3.3.2 Measuring Instruments

The measuring equipment is listed in the section 4 of this test report.

#### 3.3.3 Test Procedures

1. The testing follows Measurement Procedure 10.2 Method PKPSD of FCC KDB Publication No. 558074 D01 DTS Meas. Guidance v03r05
2. The RF output of EUT was connected to the spectrum analyzer by RF cable and attenuator. The path loss was compensated to the results for each measurement.
3. Set to the maximum power setting and enable the EUT transmit continuously.
4. Make the measurement with the spectrum analyzer's resolution bandwidth (RBW) = 3 kHz. Video bandwidth VBW = 10 kHz In order to make an accurate measurement, set the span to 1.5 times DTS Channel Bandwidth. (6dB BW)
5. Detector = peak, Sweep time = auto couple, Trace mode = max hold, Allow trace to fully stabilize. Use the peak marker function to determine the maximum power level.
6. Measure and record the results in the test report.

#### 3.3.4 Test Setup

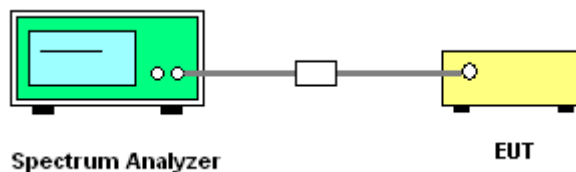



### 3.3.5 Test Result of Power Spectral Density

Please refer to Appendix A.

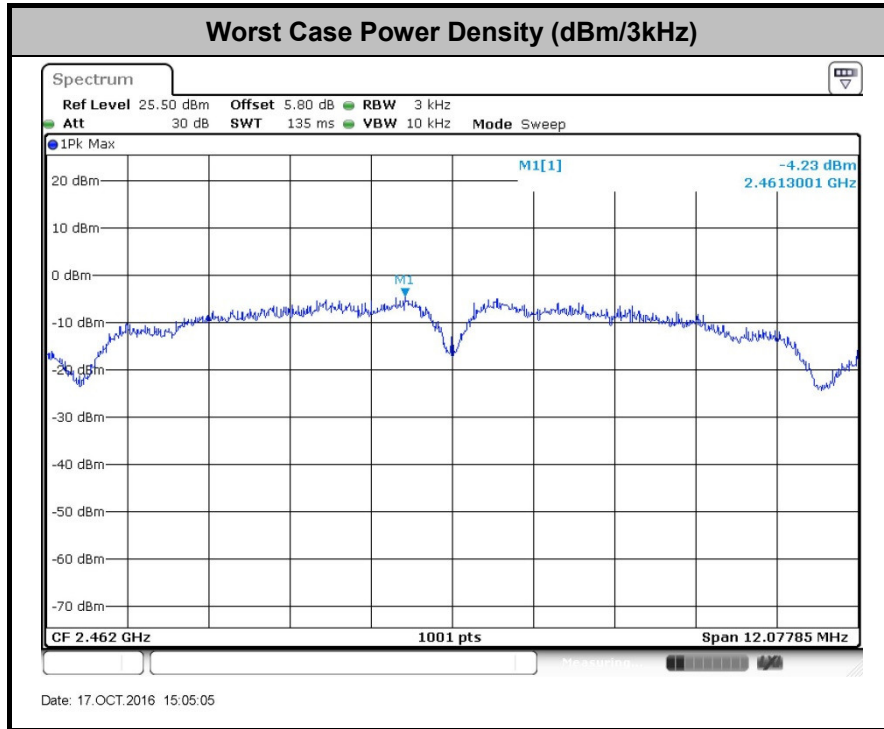

### 3.4 Conducted Band Edges and Spurious Emission Measurement

#### 3.4.1 Limit of Conducted Band Edges and Spurious Emission Measurement

In any 100 kHz bandwidth outside of the authorized frequency band, the emissions which fall in the non-restricted bands shall be attenuated at least 20 dB / 30dB relative to the maximum PSD level in 100 kHz by RF conducted measurement and radiated emissions which fall in the restricted bands, as defined in Section 15.205(a), must also comply with the radiated emission limits specified in Section 15.209(a).

#### 3.4.2 Measuring Instruments

The measuring equipment is listed in the section 4 of this test report.

#### 3.4.3 Test Procedures

1. The testing follows FCC KDB Publication No. 558074 D01 DTS Meas. Guidance v03r05.
2. The RF output of EUT was connected to the spectrum analyzer by RF cable and attenuator. The path loss was compensated to the results for each measurement.
3. Set to the maximum power setting and enable the EUT transmit continuously.
4. Set RBW = 100 kHz, VBW=300 kHz, Peak Detector. Unwanted Emissions measured in any 100 kHz bandwidth outside of the authorized frequency band shall be attenuated by at least 20 dB relative to the maximum in-band peak PSD level in 100 kHz when maximum peak conducted output power procedure is used. If the transmitter complies with the conducted power limits based on the use of RMS averaging over a time interval, the attenuation required under this paragraph shall be 30 dB instead of 20 dB per 15.247(d).
5. Measure and record the results in the test report.
6. The RF fundamental frequency should be excluded against the limit line in the operating frequency band.

#### 3.4.4 Test Setup

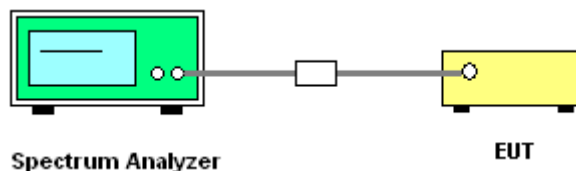



### 3.4.5 Test Result of Conducted Band Edges and Spurious Emission

Test Mode :	802.11b	Temperature :	24~25°C
Test Band :	2.4GHz Low	Relative Humidity :	54~55%
Test Channel :	01	Test Engineer :	Ivan Zhang

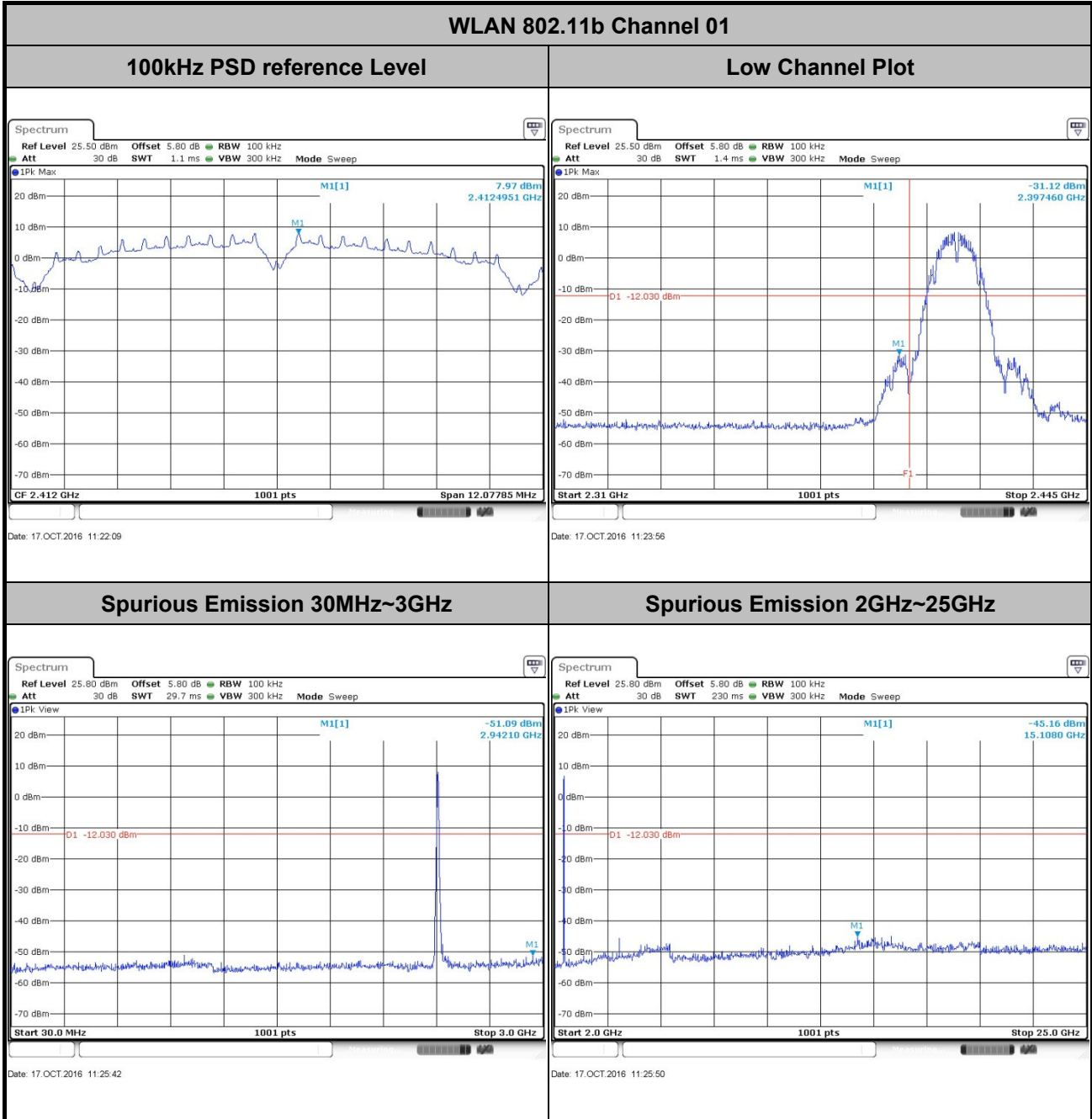



Test Mode :	802.11b	Temperature :	24~25°C
Test Band :	2.4GHz Mid	Relative Humidity :	54~55%
Test Channel :	06	Test Engineer :	Ivan Zhang

WLAN 802.11b Channel 06

100kHz PSD reference Level

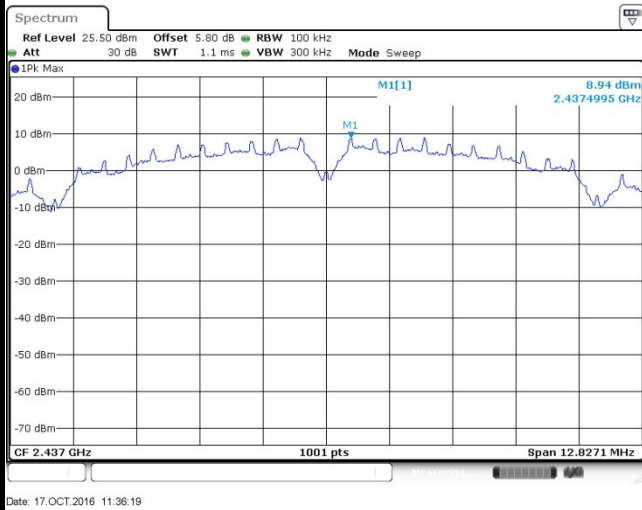

Spurious Emission 30MHz~3GHz

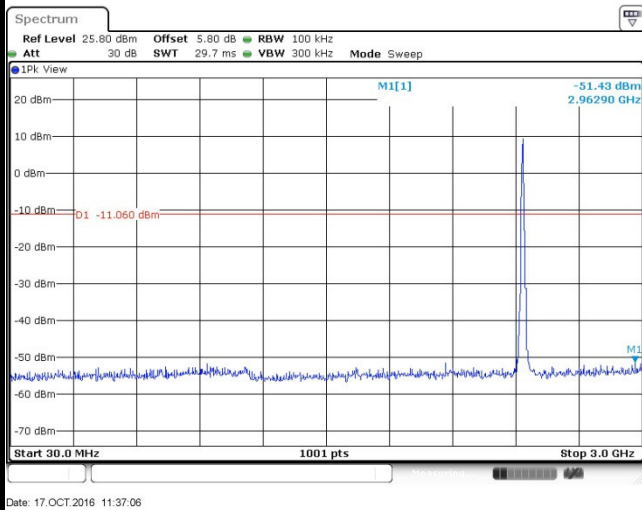

Spurious Emission 2GHz~25GHz

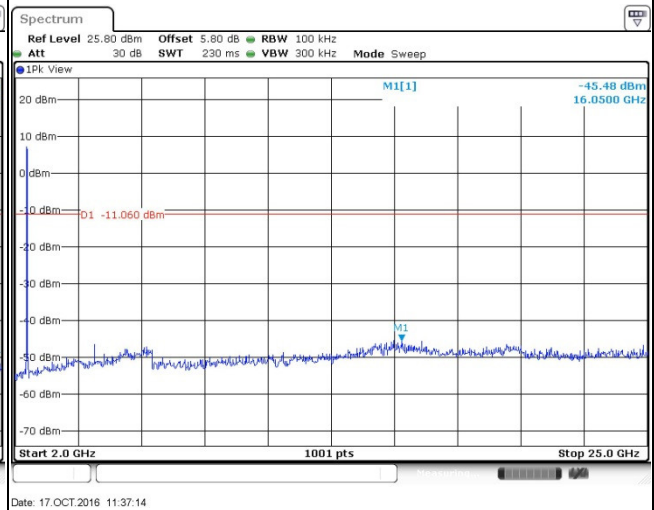



Test Mode :	802.11b	Temperature :	24~25°C
Test Band :	2.4GHz High	Relative Humidity :	54~55%
Test Channel :	11	Test Engineer :	Ivan Zhang

WLAN 802.11b Channel 11

100kHz PSD reference Level	High Channel Plot
----------------------------	-------------------

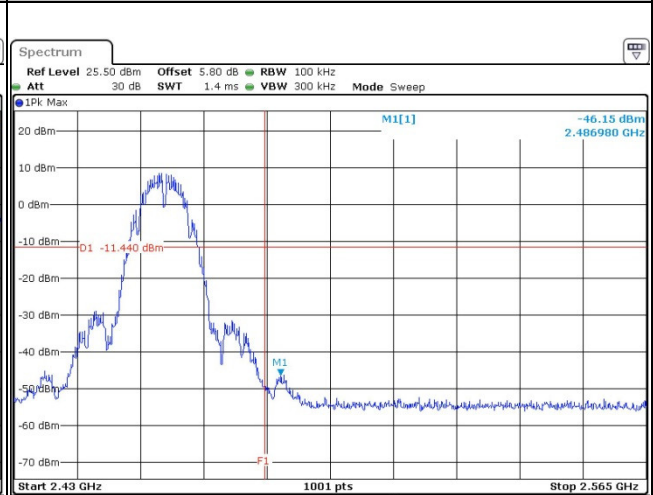
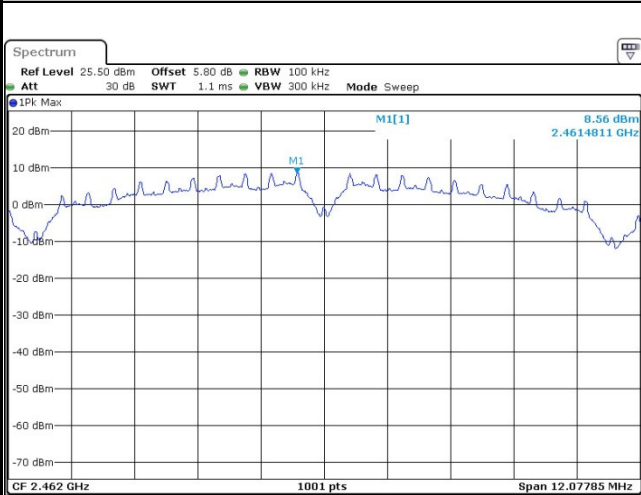

Date: 17.OCT.2016 11:41:54

Date: 17.OCT.2016 11:42:13

Spurious Emission 30MHz~3GHz

Spurious Emission 2GHz~25GHz

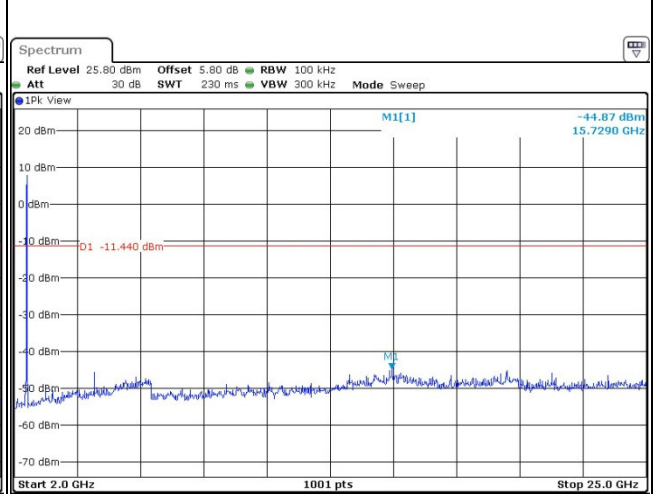
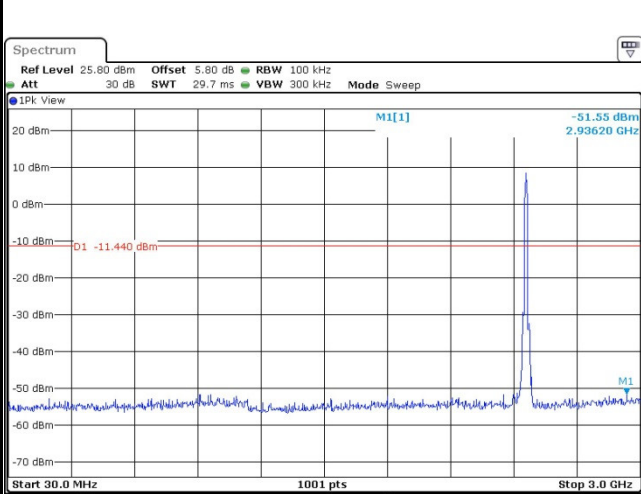

Date: 17.OCT.2016 11:52:20

Date: 17.OCT.2016 11:52:28



Test Mode :	802.11g	Temperature :	24~25°C
Test Band :	2.4GHz Low	Relative Humidity :	54~55%
Test Channel :	01	Test Engineer :	Ivan Zhang

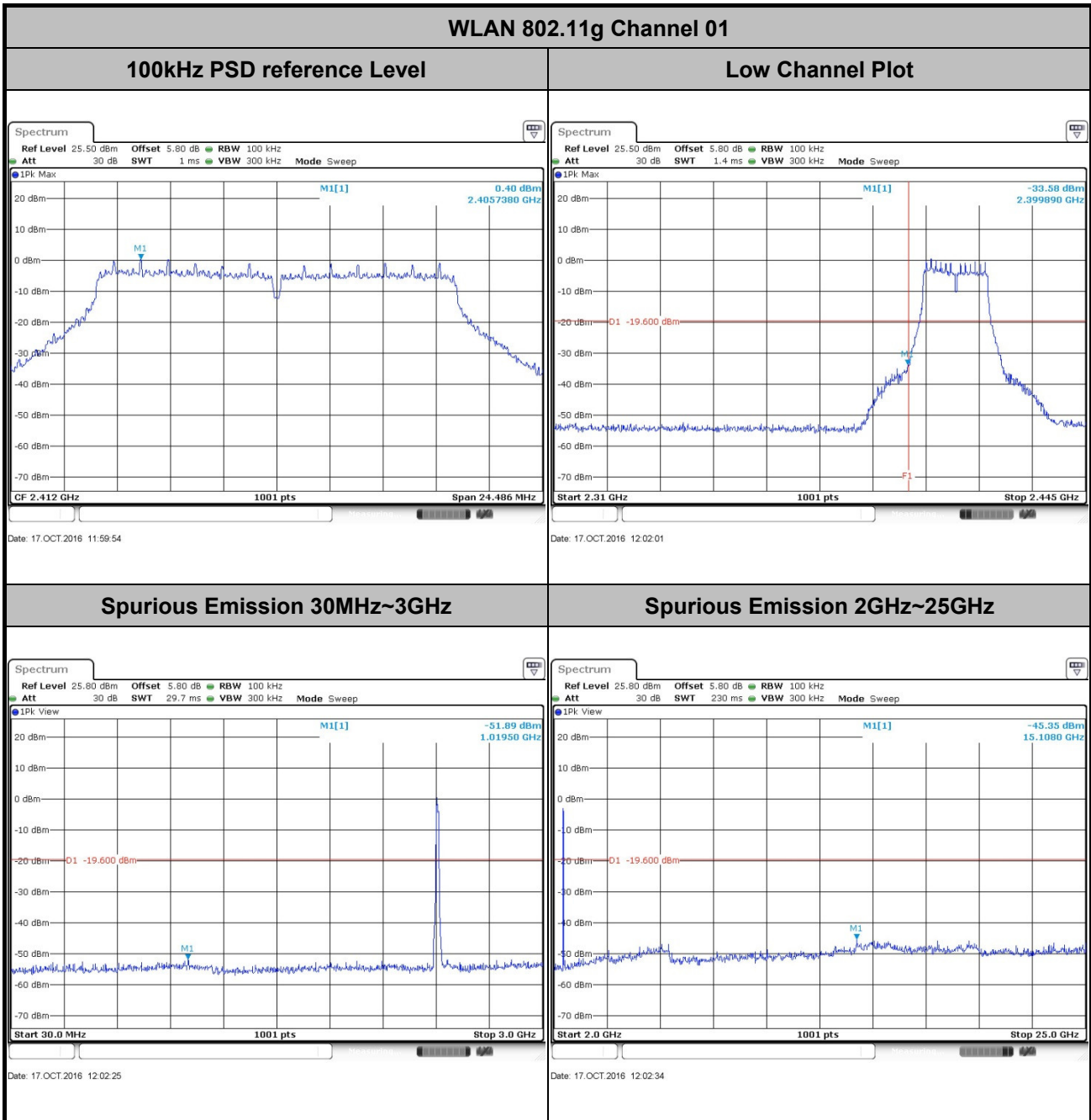





Test Mode :	802.11g	Temperature :	24~25°C
Test Band :	2.4GHz Mid	Relative Humidity :	54~55%
Test Channel :	06	Test Engineer :	Ivan Zhang

WLAN 802.11g Channel 06

100kHz PSD reference Level

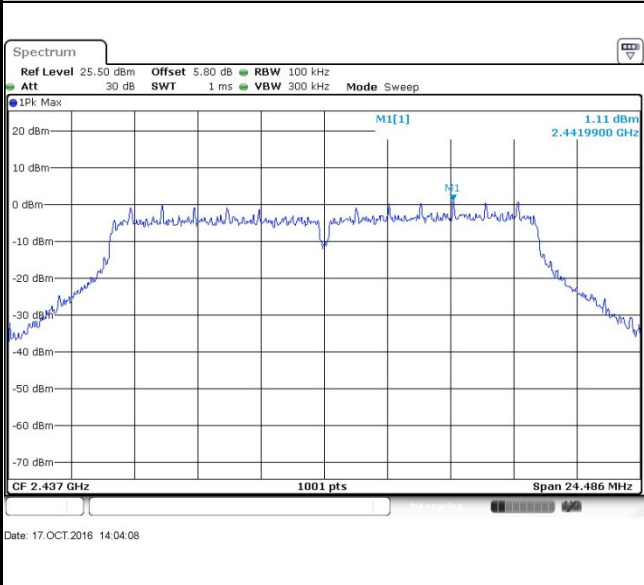

Spurious Emission 30MHz~3GHz

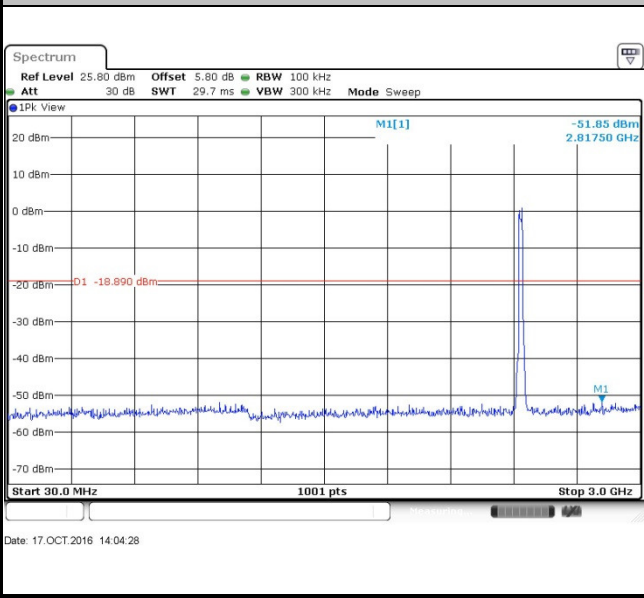

Spurious Emission 2GHz~25GHz

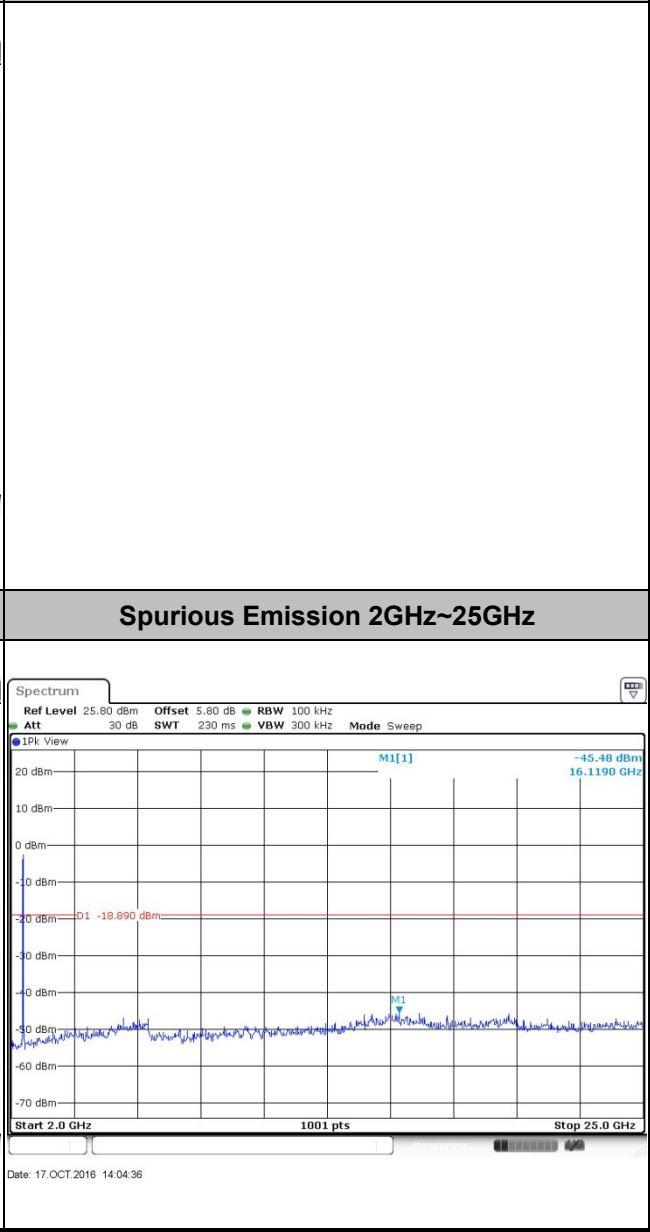



Test Mode :	802.11g	Temperature :	24~25°C
Test Band :	2.4GHz High	Relative Humidity :	54~55%
Test Channel :	11	Test Engineer :	Ivan Zhang

WLAN 802.11g Channel 11

100kHz PSD reference Level	High Channel Plot
----------------------------	-------------------

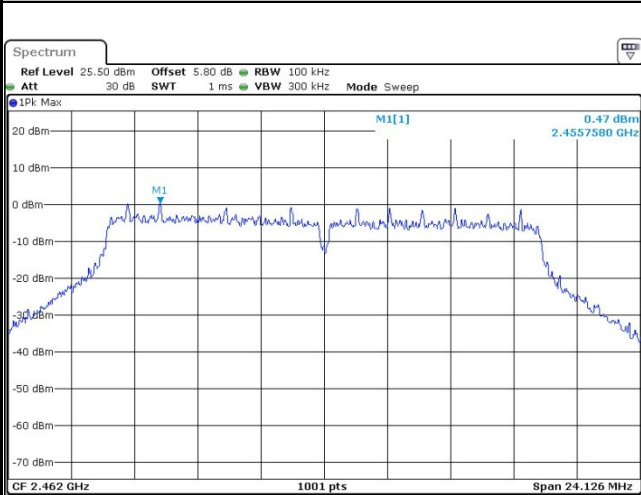

Date: 17.OCT.2016 14:07:39

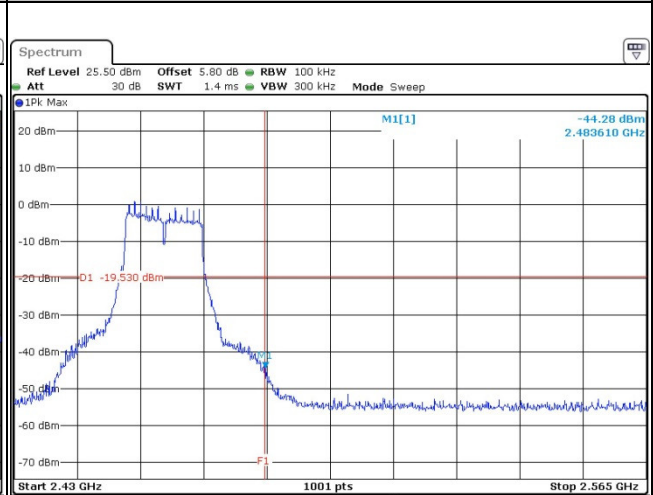

Date: 17.OCT.2016 14:07:50

Spurious Emission 30MHz~3GHz

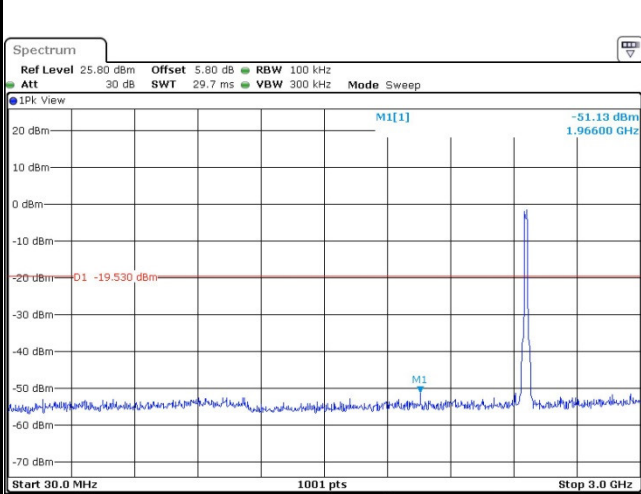

Date: 17.OCT.2016 14:08:05

Spurious Emission 2GHz~25GHz

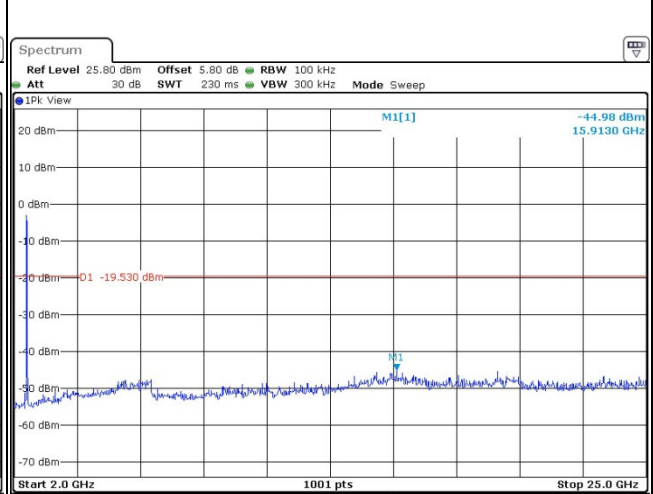

Date: 17.OCT.2016 14:08:13



Test Mode :	802.11n HT20	Temperature :	24~25°C
Test Band :	2.4GHz Low	Relative Humidity :	54~55%
Test Channel :	01	Test Engineer :	Ivan Zhang

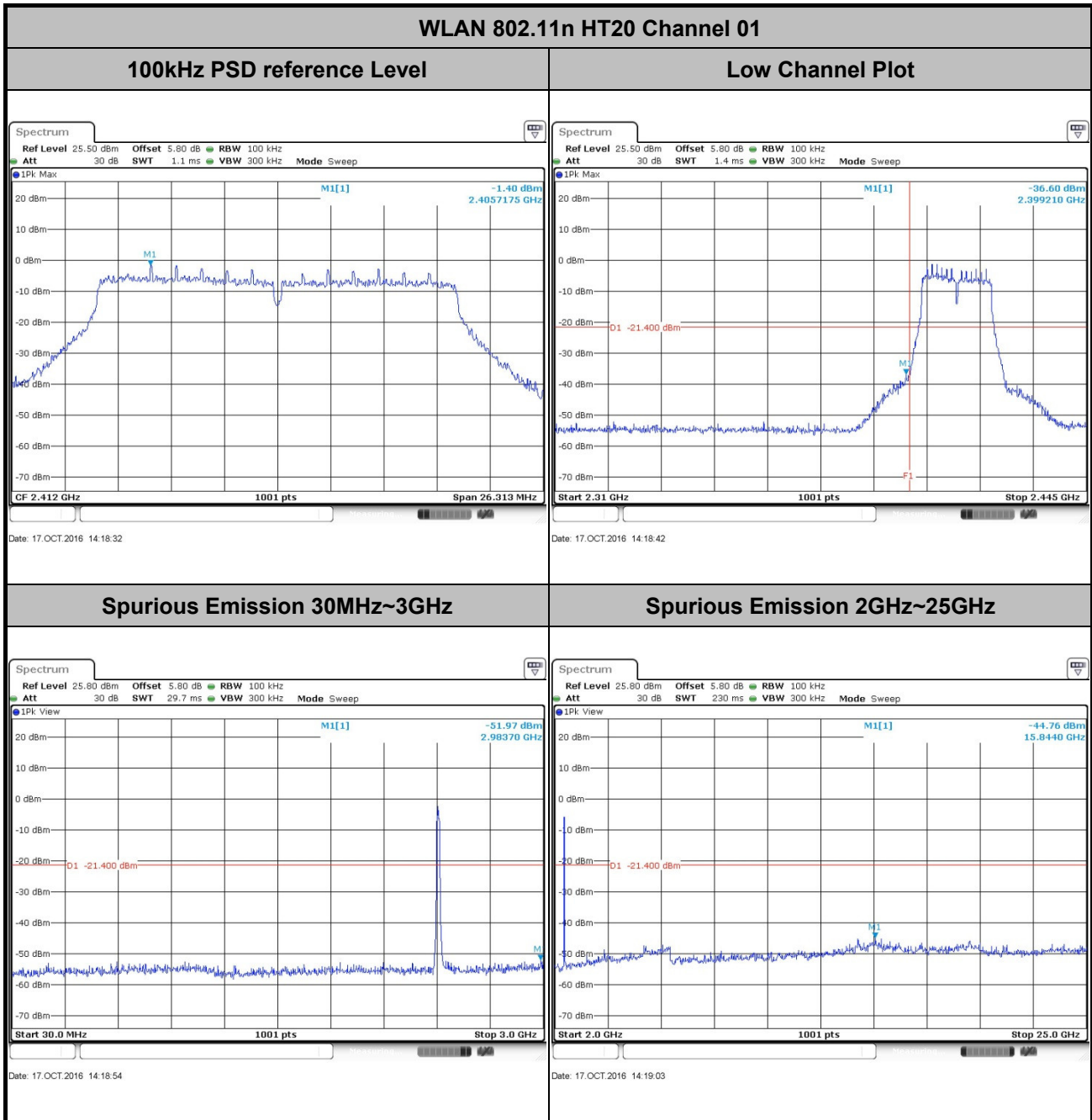



Test Mode :	802.11n HT20	Temperature :	24~25°C
Test Band :	2.4GHz Mid	Relative Humidity :	54~55%
Test Channel :	06	Test Engineer :	Ivan Zhang

WLAN 802.11n HT20 Channel 06

100kHz PSD reference Level

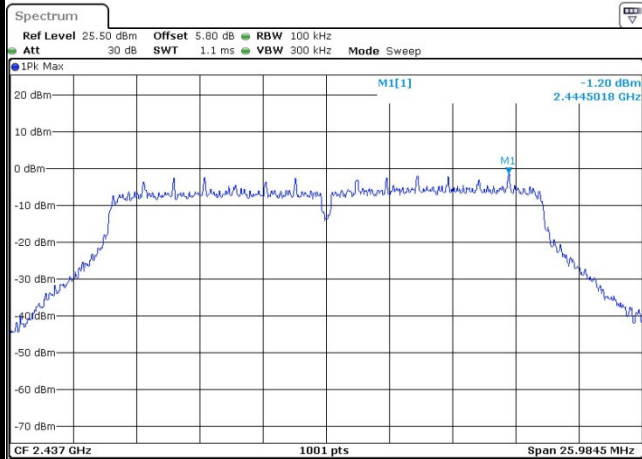

Spurious Emission 30MHz~3GHz

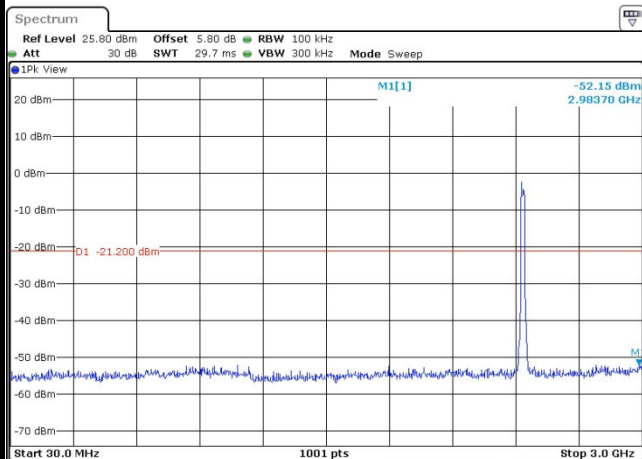

Spurious Emission 2GHz~25GHz

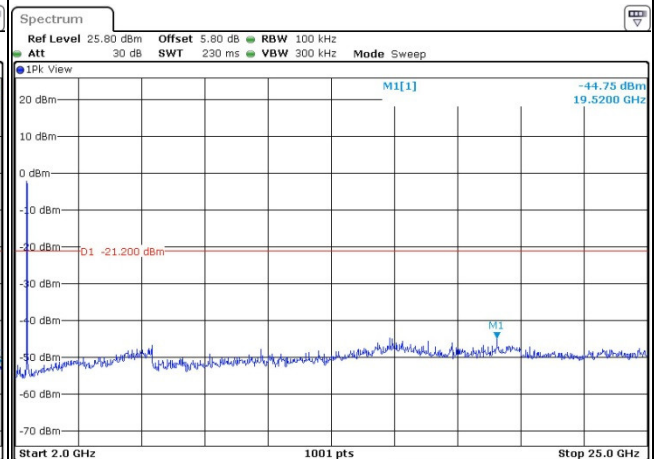



Test Mode :	802.11n HT20	Temperature :	24~25°C
Test Band :	2.4GHz High	Relative Humidity :	54~55%
Test Channel :	11	Test Engineer :	Ivan Zhang

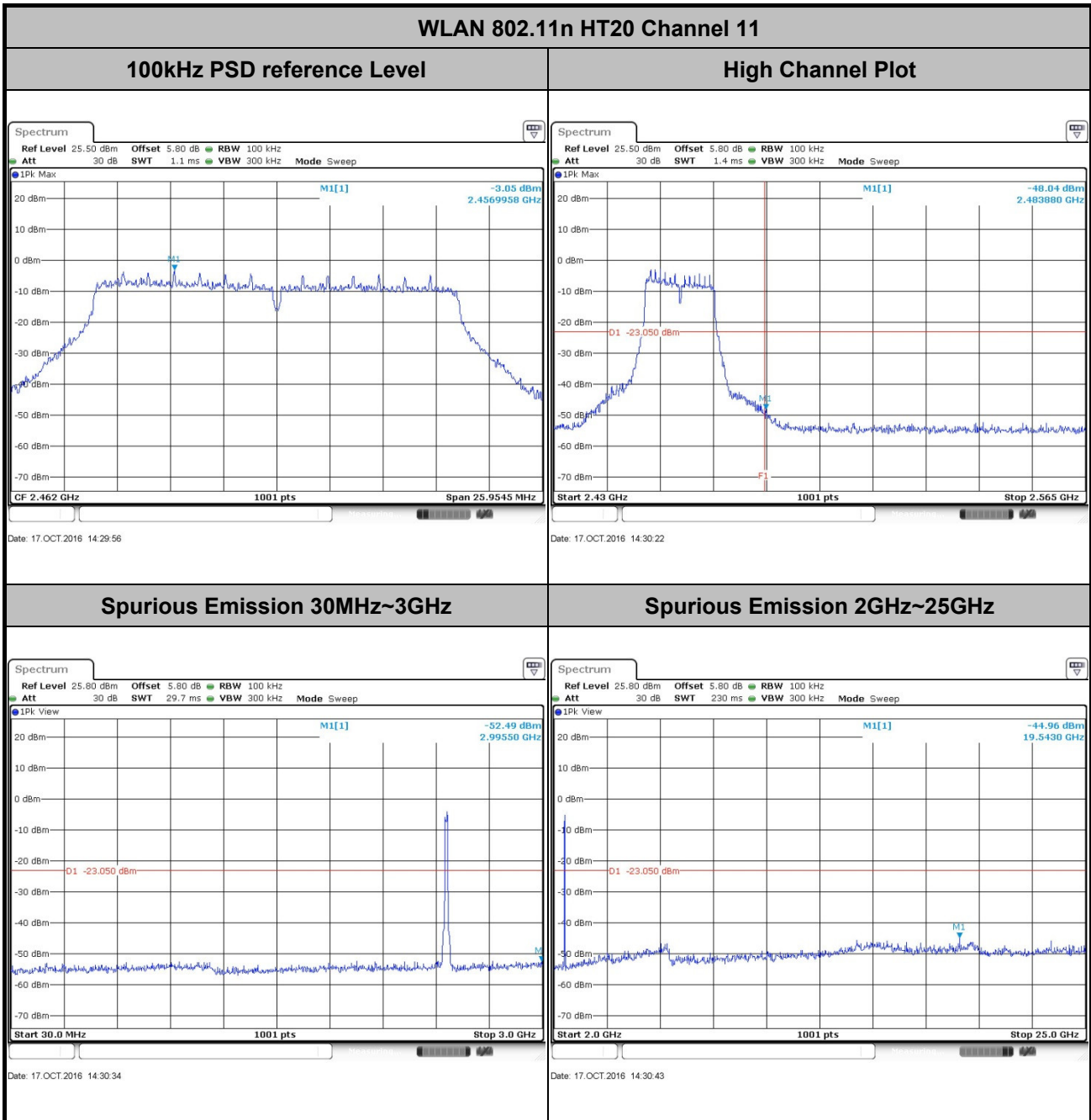



### 3.5 Radiated Band Edges and Spurious Emission Measurement

#### 3.5.1 Limit of Radiated band edge and Spurious Emission Measurement

In any 100 kHz bandwidth outside the intentional radiator frequency band, all harmonics/spurious must be at least 20 dB below the highest emission level within the authorized band. If the output power of this device was measured by spectrum analyzer, the attenuation under this paragraph shall be 30 dB instead of 20 dB. In addition, radiated emissions which fall in the restricted bands must also comply with the FCC section 15.209 limits as below.

Frequency (MHz)	Field Strength (microvolts/meter)	Measurement Distance (meters)
0.009 – 0.490	2400/F(kHz)	300
0.490 – 1.705	24000/F(kHz)	30
1.705 – 30.0	30	30
30 – 88	100	3
88 – 216	150	3
216 - 960	200	3
Above 960	500	3

#### 3.5.2 Measuring Instruments

The measuring equipment is listed in the section 4 of this test report.



### **3.5.3 Test Procedures**

1. The testing follows FCC KDB Publication No. 558074 D01 DTS Meas. Guidance v03r05.
2. The EUT was arranged to its worst case and then tune the antenna tower (from 1 m to 4 m) and turntable (from 0 degree to 360 degrees) to find the maximum reading. A pre-amp and a high pass filter are used for the test in order to get better signal level.
3. The EUT was placed on a turntable with 0.8 meter for frequency below 1GHz and 1.5 meter for frequency above 1GHz respectively above ground.
4. The EUT was set 3 meters from the interference receiving antenna, which was mounted on the top of a variable height antenna tower.
5. Corrected Reading: Antenna Factor + Cable Loss + Read Level - Preamp Factor = Level
6. For measurement below 1GHz, If the emission level of the EUT measured by the peak detector is 3 dB lower than the applicable limit, the peak emission level will be reported. Otherwise, the emission measurement will be repeated using the quasi-peak detector and reported.
7. Use the following spectrum analyzer settings:
  - (1) Span shall wide enough to fully capture the emission being measured;
  - (2) Set RBW=100 kHz for  $f < 1$  GHz; VBW  $\geq$  RBW; Sweep = auto; Detector function = peak; Trace = max hold;
  - (3) Set RBW = 1 MHz, VBW= 3MHz for  $f \geq 1$  GHz for peak measurement.

For average measurement:

    - VBW = 10 Hz, when duty cycle is no less than 98 percent.
    - VBW  $\geq 1/T$ , when duty cycle is less than 98 percent where T is the minimum transmission duration over which the transmitter is on and is transmitting at its maximum power control level for the tested mode of operation.

### 3.5.4 Test Setup

For radiated emissions below 30MHz

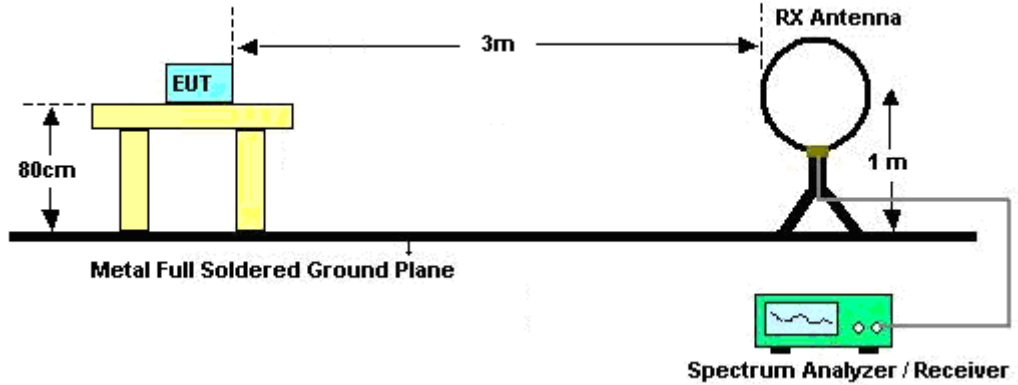

For radiated emissions from 30MHz to 1GHz

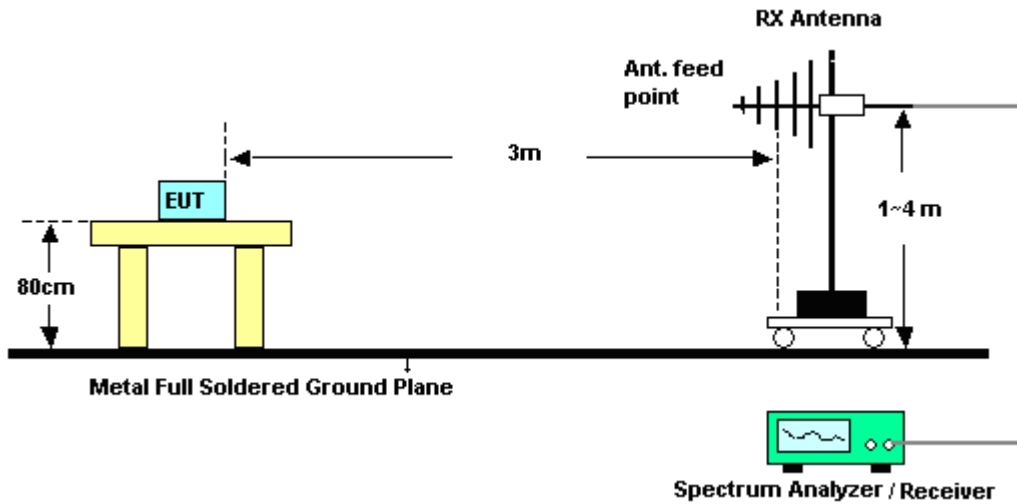



For radiated emissions above 1GHz

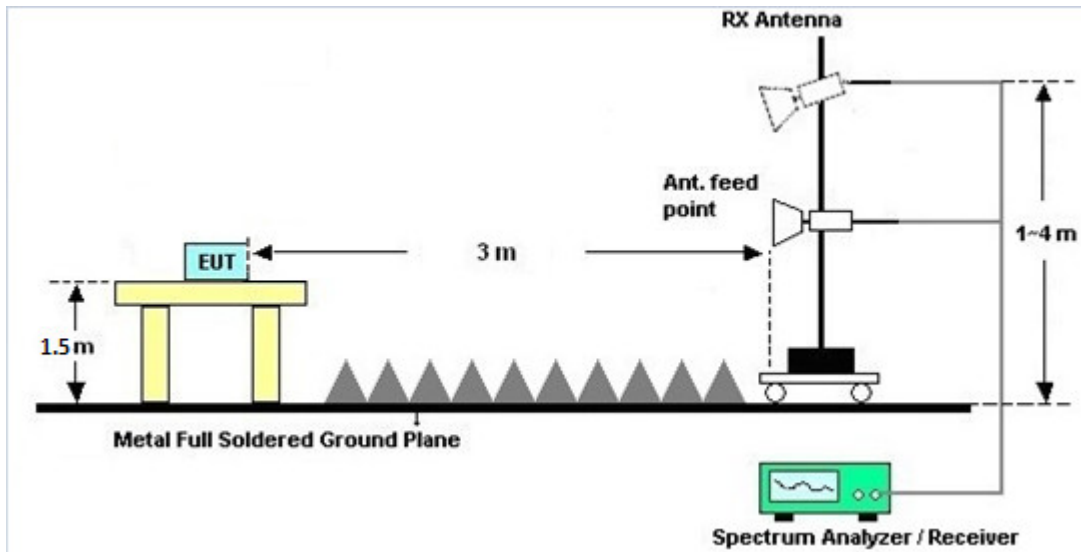

### 3.5.5 Test Results of Radiated Spurious Emissions (9kHz ~ 30MHz)

The low frequency, which started from 9 kHz to 30MHz, was pre-scanned and the result which was 20dB lower than the limit line per 15.31(o) was not reported.

### 3.5.6 Test Result of Radiated Spurious at Band Edges

Please refer to Appendix B.

### 3.5.7 Duty Cycle

Please refer to Appendix C.

### 3.5.8 Test Result of Radiated Spurious Emission (30MHz ~ 10<sup>th</sup> Harmonic)

Please refer to Appendix B.



### 3.6 AC Conducted Emission Measurement

#### 3.6.1 Limit of AC Conducted Emission

For equipment that is designed to be connected to the public utility (AC) power line, the radio frequency voltage that is conducted back onto the AC power line on any frequency or frequencies within the band 150 kHz to 30 MHz shall not exceed the limits in the following table.

Frequency of Emission (MHz)	Conducted Limit (dB $\mu$ V)	
	Quasi-Peak	Average
0.15-0.5	66 to 56*	56 to 46*
0.5-5	56	46
5-30	60	50

\*Decreases with the logarithm of the frequency.

#### 3.6.2 Measuring Instruments

The measuring equipment is listed in the section 4 of this test report.

#### 3.6.3 Test Procedures

1. The EUT was placed 0.4 meter from the conducting wall of the shielding room, and it was kept at least 80 centimeters from any other grounded conducting surface.
2. Connect EUT to the power mains through a line impedance stabilization network (LISN).
3. All the support units are connecting to the other LISN.
4. The LISN provides 50 ohm coupling impedance for the measuring instrument.
5. The FCC states that a 50 ohm, 50 microhenry LISN should be used.
6. Both sides of AC line were checked for maximum conducted interference.
7. The frequency range from 150 kHz to 30 MHz was searched.
8. Set the test-receiver system to Peak Detect Function and specified bandwidth (IF bandwidth = 9kHz) with Maximum Hold Mode.

### 3.6.4 Test Setup

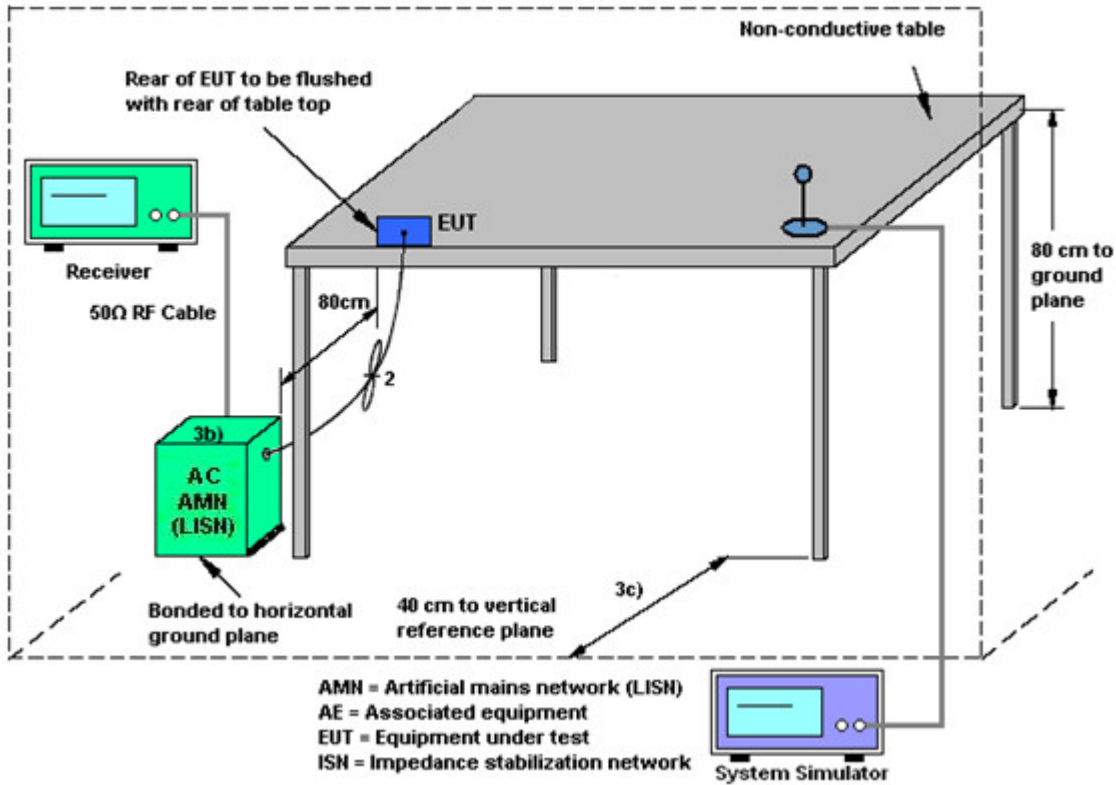



3.6.5 Test Result of AC Conducted Emission

Test Mode :	Mode 1	Temperature :	22~24°C
Test Engineer :	Amos Zhang	Relative Humidity :	43~47%
Test Voltage :	120Vac / 60Hz	Phase :	Line
Function Type :	GSM850 Idle + Bluetooth Link + WLAN (2.4G) Link + USB Cable (Charging from Adapter) + Earphone		

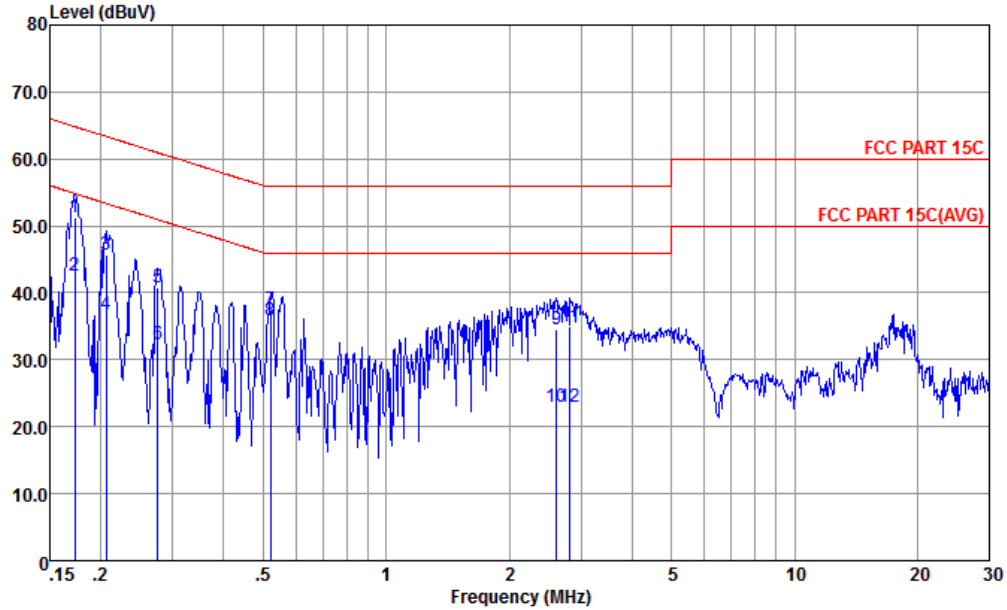

Site : CO01-KS  
 Condition : FCC PART 15C LISN-L-20151024 LINE  
 Project : (FR) 693004  
 mode : Mode 1  
 : 351864080029238/351864080029246

	Freq	Level	Over Limit	Limit Line	Read Level	LISN Factor	Cable Loss	Remark
	MHz	dBuV	dB	dBuV	dBuV	dB	dB	
1	0.173	51.34	-13.47	64.81	40.60	0.38	10.36	QP
2	0.173	42.64	-12.17	54.81	31.90	0.38	10.36	Average
3	0.206	45.75	-17.61	63.36	35.20	0.22	10.33	QP
4	0.206	36.75	-16.61	53.36	26.20	0.22	10.33	Average
5	0.276	40.69	-20.25	60.94	30.20	0.22	10.27	QP
6	0.276	32.39	-18.55	50.94	21.90	0.22	10.27	Average
7	0.521	37.52	-18.48	56.00	27.10	0.23	10.19	QP
8 *	0.521	35.92	-10.08	46.00	25.50	0.23	10.19	Average
9	2.608	34.59	-21.41	56.00	24.20	0.18	10.21	QP
10	2.608	22.99	-23.01	46.00	12.60	0.18	10.21	Average
11	2.824	35.00	-21.00	56.00	24.61	0.18	10.21	QP
12	2.824	22.90	-23.10	46.00	12.51	0.18	10.21	Average



Test Mode :	Mode 1	Temperature :	22~24°C
Test Engineer :	Amos Zhang	Relative Humidity :	43~47%
Test Voltage :	120Vac / 60Hz	Phase :	Neutral
Function Type :	GSM850 Idle + Bluetooth Link + WLAN (2.4G) Link + USB Cable (Charging from Adapter) + Earphone		

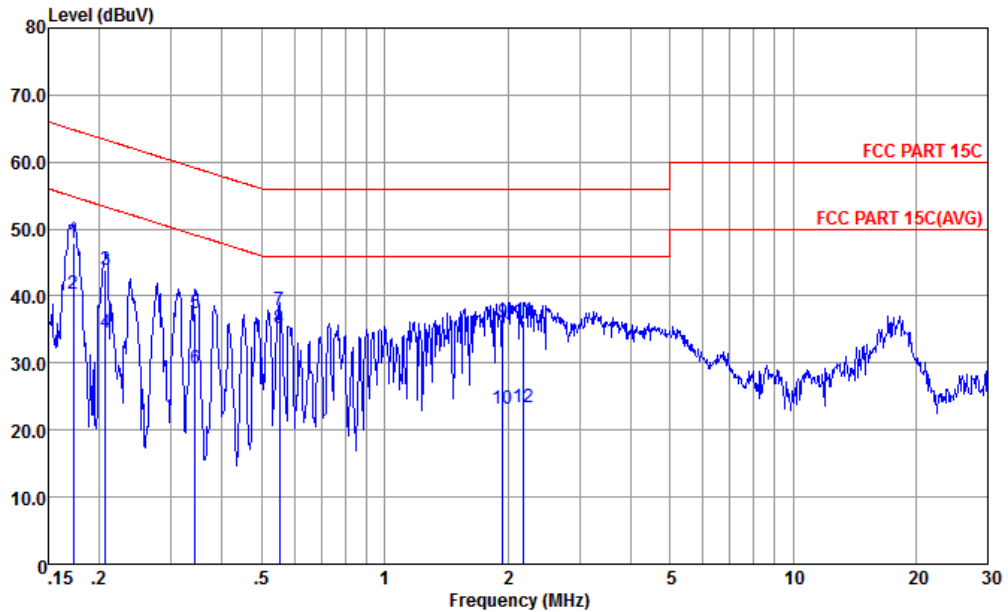

Site : CO01-KS  
 Condition : FCC PART 15C LISN-N-20151024 NEUTRAL  
 Project : (FR) 693004  
 mode : Mode 1  
 : 351864080029238/351864080029246

	Freq	Level	Over Limit	Limit Line	Read Level	LISN Factor	Cable Loss	Remark
	MHz	dBuV	dB	dBuV	dBuV	dB	dB	
1	0.173	47.97	-16.84	64.81	37.31	0.30	10.36	QP
2	0.173	40.27	-14.54	54.81	29.61	0.30	10.36	Average
3	0.207	43.94	-19.38	63.32	33.30	0.31	10.33	QP
4	0.207	34.54	-18.78	53.32	23.90	0.31	10.33	Average
5	0.343	37.44	-21.69	59.13	26.89	0.32	10.23	QP
6	0.343	29.14	-19.99	49.13	18.59	0.32	10.23	Average
7	0.552	37.81	-18.19	56.00	27.30	0.33	10.18	QP
8 *	0.552	35.11	-10.89	46.00	24.60	0.33	10.18	Average
9	1.949	36.07	-19.93	56.00	25.50	0.38	10.19	QP
10	1.949	23.07	-22.93	46.00	12.50	0.38	10.19	Average
11	2.190	36.37	-19.63	56.00	25.80	0.38	10.19	QP
12	2.190	23.47	-22.53	46.00	12.90	0.38	10.19	Average



## **3.7 Antenna Requirements**

### **3.7.1 Standard Applicable**

If directional gain of transmitting antennas is greater than 6dBi, the power shall be reduced by the same level in dB comparing to gain minus 6dBi. The use of a permanently attached antenna or of an antenna that uses a unique coupling to the intentional radiator shall be considered sufficient to comply with the FCC rule.

### **3.7.2 Antenna Anti-Replacement Construction**

An embedded-in antenna design is used.

### **3.7.3 Antenna Gain**

The antenna peak gain of EUT is less than 6 dBi. Therefore, it is not necessary to reduce maximum peak output power limit.



## 4 List of Measuring Equipment

Instrument	Manufacturer	Model No.	Serial No.	Characteristics	Calibration Date	Test Date	Due Date	Remark
Spectrum Analyzer	R&S	FSV40	101040	10Hz~40GHz	Aug. 09, 2016	Oct. 17, 2016	Aug. 08, 2017	Conducted (TH01-KS)
Pulse Power Sensor	Anritsu	MA2411B	0917070	300MHz~40GHz	Jan. 20, 2016	Oct. 17, 2016	Jan. 19, 2017	Conducted (TH01-KS)
Power Meter	Anritsu	ML2495A	1005002	50MHz Bandwidth	Jan. 20, 2016	Oct. 17, 2016	Jan. 19, 2017	Conducted (TH01-KS)
EMI Test Receiver	R&S	ESCI	100534	9kHz~3GHz	Oct. 24, 2015	Oct. 08, 2016~ Oct. 14, 2016	Oct. 23, 2016	Radiation (03CH03-KS)
EXA Spectrum Analyzer	Keysight	N9010A	MY55150244	10Hz~44GHz	Apr. 22, 2016	Oct. 08, 2016~ Oct. 14, 2016	Apr. 21, 2017	Radiation (03CH03-KS)
Loop Antenna	R&S	HFH2-Z2	100321	9kHz~30MHz	Nov. 07, 2015	Oct. 08, 2016~ Oct. 14, 2016	Nov. 06, 2016	Radiation (03CH03-KS)
Bilog Antenna	TeseQ	CBL6112D	35406	25MHz~2GHz	Apr. 16, 2016	Oct. 08, 2016~ Oct. 14, 2016	Apr. 15, 2017	Radiation (03CH03-KS)
Horn Antenna	Schwarzbeck	BBHA9120D	9120D-1356	1GHz~18GHz	Apr. 16, 2016	Oct. 08, 2016~ Oct. 14, 2016	Apr. 15, 2017	Radiation (03CH03-KS)
SHF-EHF Horn	Schwarzbeck	BBHA 9170	BBHA170249	15GHz~40GHz	Mar. 03, 2016	Oct. 08, 2016~ Oct. 14, 2016	Mar. 02, 2017	Radiation (03CH03-KS)
Amplifier	SONOMA	310N	187289	9kHz~1GHz	Aug. 09, 2016	Oct. 08, 2016~ Oct. 14, 2016	Aug. 08, 2017	Radiation (03CH03-KS)
High Gain Amplifier	MITEQ	AMF-7D-0010 1800-30-10P	1943529	1GHz~18GHz	Jan. 20, 2016	Oct. 08, 2016~ Oct. 14, 2016	Jan. 19, 2017	Radiation (03CH03-KS)
Amplifier	Agilent	8449B	3008A02370	1GHz~26.5GHz	Oct. 24, 2015	Oct. 08, 2016~ Oct. 14, 2016	Oct. 23, 2016	Radiation (03CH03-KS)
AC Power Source	Chroma	61601	F104090004	N/A	NCR	Oct. 08, 2016~ Oct. 14, 2016	NCR	Radiation (03CH03-KS)
Turn Table	ChamPro	EM 1000-T	060762-T	0~360 degree	NCR	Oct. 08, 2016~ Oct. 14, 2016	NCR	Radiation (03CH03-KS)
Antenna Mast	ChamPro	EM 1000-A	060762-A	1 m~4 m	NCR	Oct. 08, 2016~ Oct. 14, 2016	NCR	Radiation (03CH03-KS)
EMI Receiver	R&S	ESCI7	100768	9kHz~7GHz;	Apr. 29, 2016	Oct. 11, 2016	Apr. 28, 2017	Conduction (CO01-KS)
AC LISN	MessTec	AN3016	060103	9kHz~30MHz	Oct. 24, 2015	Oct. 11, 2016	Oct. 23, 2016	Conduction (CO01-KS)
AC LISN (for auxiliary equipment)	MessTec	AN3016	060105	9kHz~30MHz	Oct. 24, 2015	Oct. 11, 2016	Oct. 23, 2016	Conduction (CO01-KS)
AC Power Source	Chroma	61602	ABP00000811	AC 0V~300V, 45Hz~1000Hz	Oct. 24, 2015	Oct. 11, 2016	Oct. 23, 2016	Conduction (CO01-KS)

NCR: No Calibration Required



## 5 Uncertainty of Evaluation

### Uncertainty of Conducted Emission Measurement (150kHz ~ 30MHz)

Measuring Uncertainty for a Level of Confidence of 95% ( $U = 2Uc(y)$ )	2.3 dB
---	--------

### Uncertainty of Radiated Emission Measurement (30 MHz ~ 1000 MHz)

Measuring Uncertainty for a Level of Confidence of 95% ( $U = 2Uc(y)$ )	4.5 dB
---	--------

### Uncertainty of Radiated Emission Measurement (1GHz ~ 18GHz)

Measuring Uncertainty for a Level of Confidence of 95% ( $U = 2Uc(y)$ )	4.5 dB
---	--------

### Uncertainty of Radiated Emission Measurement (18GHz ~ 40GHz)

Measuring Uncertainty for a Level of Confidence of 95% ( $U = 2Uc(y)$ )	4.6 dB
---	--------





## **Appendix A. Conducted Test Results**

**A1 - DTS Part**

Test Engineer:	Ivan Zhang	Temperature:	24~25	°C
Test Date:	2016/10/17	Relative Humidity:	54~55	%

**TEST RESULTS DATA**  
**6dB and 99% Occupied Bandwidth**

2.4GHz Band								
Mod.	Data Rate	NTX	CH.	Freq. (MHz)	99% Occupied BW (MHz)	6dB BW (MHz)	6dB BW Limit (MHz)	Pass/Fail
11b	1Mbps	1	1	2412	13.74	8.05	0.50	Pass
11b	1Mbps	1	6	2437	13.69	8.55	0.50	Pass
11b	1Mbps	1	11	2462	13.69	8.05	0.50	Pass
11g	6Mbps	1	1	2412	18.53	16.32	0.50	Pass
11g	6Mbps	1	6	2437	18.48	16.32	0.50	Pass
11g	6Mbps	1	11	2462	18.68	16.08	0.50	Pass
HT20	MCS0	1	1	2412	19.48	17.54	0.50	Pass
HT20	MCS0	1	6	2437	19.13	17.32	0.50	Pass
HT20	MCS0	1	11	2462	19.23	17.30	0.50	Pass

**TEST RESULTS DATA**  
**Peak Power Table**

2.4GHz Band										
Mod.	Data Rate	NTX	CH.	Freq. (MHz)	Peak Conducted Power (dBm)	Conducted Power Limit (dBm)	DG (dBi)	EIRP Power (dBm)	EIRP Power Limit (dBm)	Pass /Fail
11b	1Mbps	1	1	2412	19.02	30.00	-1.55	17.47	36.00	Pass
11b	1Mbps	1	6	2437	20.22	30.00	-1.55	18.67	36.00	Pass
11b	1Mbps	1	11	2462	19.66	30.00	-1.55	18.11	36.00	Pass
11g	6Mbps	1	1	2412	19.92	30.00	-1.55	18.37	36.00	Pass
11g	6Mbps	1	6	2437	20.82	30.00	-1.55	19.27	36.00	Pass
11g	6Mbps	1	11	2462	20.43	30.00	-1.55	18.88	36.00	Pass
HT20	MCS0	1	1	2412	19.42	30.00	-1.55	17.87	36.00	Pass
HT20	MCS0	1	6	2437	19.51	30.00	-1.55	17.96	36.00	Pass
HT20	MCS0	1	11	2462	18.33	30.00	-1.55	16.78	36.00	Pass

**TEST RESULTS DATA**  
**Average Power Table**  
**(Reporting Only)**

2.4GHz Band						
Mod.	Data Rate	NTX	CH.	Freq. (MHz)	Duty Factor (dB)	Average Conducted Power (dBm)
11b	1Mbps	1	1	2412	0.09	16.40
11b	1Mbps	1	6	2437	0.09	17.53
11b	1Mbps	1	11	2462	0.09	16.81
11g	6Mbps	1	1	2412	0.60	10.73
11g	6Mbps	1	6	2437	0.60	11.75
11g	6Mbps	1	11	2462	0.60	11.12
HT20	MCS0	1	1	2412	0.63	10.61
HT20	MCS0	1	6	2437	0.63	10.51
HT20	MCS0	1	11	2462	0.63	9.29

**TEST RESULTS DATA**  
**Peak Power Density**

2.4GHz Band								
Mod.	Data Rate	NTX	CH.	Freq. (MHz)	Peak PSD (dBm /3kHz)	DG (dBi)	Peak PSD Limit (dBm /3kHz)	Pass/Fail
11b	1Mbps	1	1	2412	-4.99	-1.55	8.00	Pass
11b	1Mbps	1	6	2437	-4.63	-1.55	8.00	Pass
11b	1Mbps	1	11	2462	-4.23	-1.55	8.00	Pass
11g	6Mbps	1	1	2412	-13.09	-1.55	8.00	Pass
11g	6Mbps	1	6	2437	-13.33	-1.55	8.00	Pass
11g	6Mbps	1	11	2462	-13.38	-1.55	8.00	Pass
HT20	MCS0	1	1	2412	-15.84	-1.55	8.00	Pass
HT20	MCS0	1	6	2437	-14.76	-1.55	8.00	Pass
HT20	MCS0	1	11	2462	-16.86	-1.55	8.00	Pass



## Appendix B. Radiated Spurious Emission

2.4GHz 2400~2483.5MHz

WIFI 802.11b (Band Edge @ 3m)

WIFI	Note	Frequency	Level	Over	Limit	Read	Antenna	Cable	Preamp	Ant	Table	Peak	Pol.
Ant.				Limit	Line	Level	Factor	Loss	Factor	Pos	Pos	Avg.	
1		( MHz )	( dBμV/m )	( dB )	( dBμV/m )	( dBμV )	( dB/m )	( dB )	( dB )	( cm )	( deg )	(P/A)	(H/V)
802.11b CH 01 2412MHz		2386.96	53.97	-20.03	74	58.52	27	5.47	37.02	220	140	P	H
		2387.35	45.41	-8.59	54	49.96	27	5.47	37.02	220	140	A	H
	*	2412	104.28	-	-	108.68	27.13	5.47	37	220	140	P	H
	*	2410	101.03	-	-	105.43	27.13	5.47	37	220	140	A	H
		2387.48	51.96	-22.04	74	56.51	27	5.47	37.02	100	294	P	V
		2387.35	42.57	-11.43	54	47.12	27	5.47	37.02	100	294	A	V
	*	2412	98.84	-	-	103.24	27.13	5.47	37	100	294	P	V
	*	2410	95.57	-	-	99.97	27.13	5.47	37	100	294	A	V
802.11b CH 06 2437MHz		2389.04	51.12	-22.88	74	55.67	27	5.47	37.02	181	142	P	H
		2389.56	40.47	-13.53	54	45.02	27	5.47	37.02	181	142	A	H
		2485.18	52.22	-21.78	74	56.01	27.64	5.51	36.94	181	142	P	H
		2484.34	41.37	-12.63	54	45.16	27.64	5.51	36.94	181	142	A	H
	*	2438	106.71	-	-	110.8	27.39	5.49	36.97	181	142	P	H
	*	2438	103.71	-	-	107.8	27.39	5.49	36.97	181	142	A	H
		2361.09	50.16	-23.84	74	54.84	26.91	5.43	37.02	389	81	P	V
		2389.69	39.88	-14.12	54	44.43	27	5.47	37.02	389	81	A	V
		2495.02	51.66	-22.34	74	55.3	27.77	5.52	36.93	389	81	P	V
		2484.28	40.77	-13.23	54	44.56	27.64	5.51	36.94	389	81	A	V
	*	2438	101.72	-	-	105.81	27.39	5.49	36.97	389	81	P	V
*	2438	98.74	-	-	102.83	27.39	5.49	36.97	389	81	A	V	



802.11b CH 11 2462MHz	*	2462	105.53	-	-	109.48	27.51	5.5	36.96	111	100	P	H
	*	2460	102.29	-	-	106.24	27.51	5.5	36.96	111	100	A	H
		2486.38	57.1	-16.9	74	60.89	27.64	5.51	36.94	111	100	P	H
		2487.22	50.22	-3.78	54	54.01	27.64	5.51	36.94	111	100	A	H
	*	2462	102.47	-	-	106.42	27.51	5.5	36.96	377	76	P	V
	*	2464	99.21	-	-	103.16	27.51	5.5	36.96	377	76	A	V
		2487.04	55.51	-18.49	74	59.3	27.64	5.51	36.94	377	76	P	V
		2487.04	47.1	-6.9	54	50.89	27.64	5.51	36.94	377	76	A	V
Remark	1. No other spurious found. 2. All results are PASS against Peak and Average limit line.												





2.4GHz 2400~2483.5MHz
WIFI 802.11b (Harmonic @ 3m)

Table with 14 columns: WIFI Ant. 1, Note, Frequency (MHz), Level (dBµV/m), Over Limit (dB), Limit Line (dBµV/m), Read Level (dBµV), Antenna Factor (dB/m), Cable Loss (dB), Preamp Factor (dB), Ant Pos (cm), Table Pos (deg), Peak Avg. (P/A), Pol. (H/V). Rows include data for CH 01 (2412MHz), CH 06 (2437MHz), and CH 11 (2462MHz).



2.4GHz 2400~2483.5MHz
WIFI 802.11g (Band Edge @ 3m)

Table with 14 columns: WIFI Ant. 1, Note, Frequency (MHz), Level (dBµV/m), Over Limit (dB), Limit Line (dBµV/m), Read Level (dBµV), Antenna Factor (dB/m), Cable Loss (dB), Preamp Factor (dB), Ant Pos (cm), Table Pos (deg), Peak Avg. (P/A), Pol. (H/V). Rows include data for 802.11g CH 01 (2412MHz) and 802.11g CH 06 (2437MHz).



802.11g CH 11 2462MHz	*	2456	99.5	-	-	103.45	27.51	5.5	36.96	289	140	P	H
	*	2454	91.66	-	-	95.61	27.51	5.5	36.96	289	140	A	H
		2483.8	63.02	-10.98	74	66.81	27.64	5.51	36.94	289	140	P	H
		2483.5	49.29	-4.71	54	53.08	27.64	5.51	36.94	289	140	A	H
	*	2458	100.83	-	-	104.78	27.51	5.5	36.96	100	123	P	V
	*	2456	93.08	-	-	97.03	27.51	5.5	36.96	100	123	A	V
		2483.8	66.76	-7.24	74	70.55	27.64	5.51	36.94	100	123	P	V
		2483.56	50.96	-3.04	54	54.75	27.64	5.51	36.94	100	123	A	V
Remark	<ol style="list-style-type: none"> <li>No other spurious found.</li> <li>All results are PASS against Peak and Average limit line.</li> </ol>												



**2.4GHz 2400~2483.5MHz**  
**WIFI 802.11g (Harmonic @ 3m)**

WIFI Ant. 1	Note	Frequency ( MHz )	Level ( dBμV/m )	Over Limit ( dB )	Limit Line ( dBμV/m )	Read Level ( dBμV )	Antenna Factor ( dB/m )	Cable Loss ( dB )	Preamp Factor ( dB )	Ant Pos ( cm )	Table Pos ( deg )	Peak Avg. ( P/A )	Pol. ( H/V )
802.11g CH 01 2412MHz		4824	42.46	-31.54	74	39.91	31.51	7.72	36.68	100	360	P	H
		4824	43.15	-30.85	74	40.6	31.51	7.72	36.68	100	360	P	V
802.11g CH 06 2437MHz		4872	43.71	-30.29	74	41.02	31.59	7.76	36.66	100	360	P	H
		7308	45.7	-28.3	74	38.6	34.03	9.76	36.69	100	360	P	H
		4872	42.93	-31.07	74	40.24	31.59	7.76	36.66	100	360	P	V
802.11g CH 11 2462MHz		7308	45.21	-28.79	74	38.11	34.03	9.76	36.69	100	360	P	V
		4926	45.16	-28.84	74	42.34	31.67	7.8	36.65	100	360	P	H
		7386	45.19	-28.81	74	37.82	34.29	9.86	36.78	100	360	P	H
		4926	42.36	-31.64	74	39.54	31.67	7.8	36.65	100	360	P	V
		7386	44.54	-29.46	74	37.17	34.29	9.86	36.78	100	360	P	V
Remark	1. No other spurious found. 2. All results are PASS against Peak and Average limit line.												



**2.4GHz 2400~2483.5MHz  
WIFI 802.11n HT20 (Band Edge @ 3m)**

WIFI Ant. 1	Note	Frequency ( MHz )	Level ( dBμV/m )	Over Limit ( dB )	Limit Line ( dBμV/m )	Read Level ( dBμV )	Antenna Factor ( dB/m )	Cable Loss ( dB )	Preamp Factor ( dB )	Ant Pos ( cm )	Table Pos ( deg )	Peak Avg. ( P/A )	Pol. ( H/V )
802.11n HT20 CH 01 2412MHz		2389.56	69.12	-4.88	74	73.67	27	5.47	37.02	226	152	P	H
		2389.95	49.57	-4.43	54	54.12	27	5.47	37.02	226	152	A	H
	*	2408	100.19	-	-	104.59	27.13	5.47	37	226	152	P	H
	*	2408	92.46	-	-	96.86	27.13	5.47	37	226	152	A	H
		2389.69	61.18	-12.82	74	65.73	27	5.47	37.02	391	1	P	V
		2389.95	45.72	-8.28	54	50.27	27	5.47	37.02	391	1	A	V
	*	2408	99.16	-	-	103.56	27.13	5.47	37	391	1	P	V
	*	2408	91.56	-	-	95.96	27.13	5.47	37	391	1	A	V
802.11n HT20 CH 06 2437MHz		2383.84	51.64	-22.36	74	56.26	26.95	5.45	37.02	100	326	P	H
		2385.53	41.91	-12.09	54	46.46	27	5.47	37.02	100	326	A	H
		2488.72	52.98	-21.02	74	56.62	27.77	5.52	36.93	100	326	P	H
		2488.54	43.65	-10.35	54	47.29	27.77	5.52	36.93	100	326	A	H
	*	2446	101.92	-	-	106.01	27.39	5.49	36.97	100	326	P	H
	*	2446	93.97	-	-	98.06	27.39	5.49	36.97	100	326	A	H
		2376.82	50.7	-23.3	74	55.32	26.95	5.45	37.02	379	123	P	V
		2385.66	40.42	-13.58	54	44.97	27	5.47	37.02	379	123	A	V
		2489.38	52.67	-21.33	74	56.31	27.77	5.52	36.93	379	123	P	V
		2488.54	41.91	-12.09	54	45.55	27.77	5.52	36.93	379	123	A	V
	*	2446	97.97	-	-	102.06	27.39	5.49	36.97	379	123	P	V
*	2444	90.13	-	-	94.22	27.39	5.49	36.97	379	123	A	V	



<b>802.11n</b>  <b>HT20</b>  <b>CH 11</b>  <b>2462MHz</b>	*	2458	100.9	-	-	104.85	27.51	5.5	36.96	121	331	P	H
	*	2456	94.65	-	-	98.6	27.51	5.5	36.96	121	331	A	H
		2483.56	65.54	-8.46	74	69.33	27.64	5.51	36.94	121	331	P	H
		2483.5	50.86	-3.14	54	54.65	27.64	5.51	36.94	121	331	A	H
	*	2456	98.15	-	-	102.1	27.51	5.5	36.96	368	141	P	V
	*	2454	90.32	-	-	94.27	27.51	5.5	36.96	368	141	A	V
		2484.76	62.78	-11.22	74	66.57	27.64	5.51	36.94	368	141	P	V
		2483.5	48.39	-5.61	54	52.18	27.64	5.51	36.94	368	141	A	V
<b>Remark</b>	1. No other spurious found. 2. All results are PASS against Peak and Average limit line.												



**2.4GHz 2400~2483.5MHz  
WIFI 802.11n HT20 (Harmonic @ 3m)**

WIFI Ant. 1	Note	Frequency ( MHz )	Level ( dBμV/m )	Over Limit ( dB )	Limit Line ( dBμV/m )	Read Level ( dBμV )	Antenna Factor ( dB/m )	Cable Loss ( dB )	Preamp Factor ( dB )	Ant Pos ( cm )	Table Pos ( deg )	Peak Avg. ( P/A )	Pol. ( H/V )
802.11n HT20 CH 01 2412MHz		4824	42.33	-31.67	74	39.78	31.51	7.72	36.68	100	360	P	H
		4824	42.83	-31.17	74	40.28	31.51	7.72	36.68	100	360	P	V
802.11n HT20 CH 06 2437MHz		4872	41.33	-32.67	74	38.64	31.59	7.76	36.66	100	360	P	H
		7308	46.15	-27.85	74	39.05	34.03	9.76	36.69	100	360	P	H
		4872	43.3	-30.7	74	40.61	31.59	7.76	36.66	100	360	P	V
		7308	46.98	-27.02	74	39.88	34.03	9.76	36.69	100	360	P	V
802.11n HT20 CH 11 2462MHz		4926	42.31	-31.69	74	39.49	31.67	7.8	36.65	100	360	P	H
		7386	46.68	-27.32	74	39.31	34.29	9.86	36.78	100	360	P	H
		4926	41.95	-32.05	74	39.13	31.67	7.8	36.65	100	360	P	V
		7386	45.13	-28.87	74	37.76	34.29	9.86	36.78	100	360	P	V
Remark	1. No other spurious found. 2. All results are PASS against Peak and Average limit line.												



2.4GHz 2400~2483.5MHz

Emission below 1GHz

2.4GHz WIFI 802.11g (LF)

WIFI	Note	Frequency	Level	Over	Limit	Read	Antenna	Cable	Preamp	Ant	Table	Peak	Pol.
Ant.				Limit	Line	Level	Factor	Loss	Factor	Pos	Pos	Avg.	
1		( MHz )	( dBμV/m )	( dB )	( dBμV/m )	( dBμV )	( dB/m )	( dB )	( dB )	( cm )	( deg )	( P/A )	( H/V )
2.4GHz 802.11g LF		30.97	27.71	-12.29	40	31.48	26.86	0.66	31.29	-	-	P	H
		44.55	28.38	-11.62	40	39.52	19.45	0.83	31.42	100	128	P	H
		65.89	24.26	-15.74	40	41.39	13.38	0.98	31.49	-	-	P	H
		80.44	28.34	-11.66	40	43.07	15.67	1.09	31.49	-	-	P	H
		454.86	27.13	-18.87	46	30.43	25.28	2.66	31.24	-	-	P	H
		697.36	29.33	-16.67	46	30.48	26.56	3.34	31.05	-	-	P	H
		30.97	32.75	-7.25	40	36.52	26.86	0.66	31.29	-	-	P	V
		44.55	34.24	-5.76	40	45.38	19.45	0.83	31.42	100	254	P	V
		65.89	33.61	-6.39	40	50.74	13.38	0.98	31.49	-	-	P	V
		72.68	33.5	-6.5	40	49.57	14.42	1.03	31.52	-	-	P	V
		216.24	21.56	-24.44	46	35.08	16.23	1.73	31.48	-	-	P	V
		571.26	25.9	-20.1	46	29.65	24.67	2.99	31.41	-	-	P	V
Remark	1. No other spurious found. 2. All results are PASS against limit line.												





**Note symbol**

*	<b>Fundamental Frequency</b> which can be ignored. However, the level of any unwanted emissions shall not exceed the level of the fundamental frequency.
!	Test result is <b>over limit</b> line.
P/A	<b>Peak</b> or <b>Average</b>
H/V	<b>Horizontal</b> or <b>Vertical</b>



A calculation example for radiated spurious emission is shown as below:

WIFI	Note	Frequency	Level	Over	Limit	Read	Antenna	Cable	Preamp	Ant	Table	Peak	Pol.
Ant.				Limit	Line	Level	Factor	Loss	Factor	Pos	Pos	Avg.	
1		( MHz )	( dBμV/m )	( dB )	( dBμV/m )	( dBμV )	( dB/m )	( dB )	( dB )	( cm )	( deg )	( P/A )	( H/V )
802.11b		2390	55.45	-18.55	74	54.51	32.22	4.58	35.86	103	308	P	H
CH 01													
2412MHz		2390	43.54	-10.46	54	42.6	32.22	4.58	35.86	103	308	A	H

- Level(dBμV/m) =  
Antenna Factor(dB/m) + Cable Loss(dB) + Read Level(dBμV) - Preamp Factor(dB)
- Over Limit(dB) = Level(dBμV/m) – Limit Line(dBμV/m)

**For Peak Limit @ 2390MHz:**

- Level(dBμV/m)  
= Antenna Factor(dB/m) + Cable Loss(dB) + Read Level(dBμV) - Preamp Factor(dB)  
= 32.22(dB/m) + 4.58(dB) + 54.51(dBμV) – 35.86 (dB)  
= 55.45 (dBμV/m)
- Over Limit(dB)  
= Level(dBμV/m) – Limit Line(dBμV/m)  
= 55.45(dBμV/m) – 74(dBμV/m)  
= -18.55(dB)

**For Average Limit @ 2390MHz:**

- Level(dBμV/m)  
= Antenna Factor(dB/m) + Cable Loss(dB) + Read Level(dBμV) - Preamp Factor(dB)  
= 32.22(dB/m) + 4.58(dB) + 42.6(dBμV) – 35.86 (dB)  
= 43.54 (dBμV/m)
- Over Limit(dB)  
= Level(dBμV/m) – Limit Line(dBμV/m)  
= 43.54(dBμV/m) – 54(dBμV/m)  
= -10.46(dB)

Both peak and average measured complies with the limit line, so test result is “PASS”.



## Appendix C. Duty Cycle Plots

Antenna	Band	Duty Cycle(%)	T(ms)	1/T(kHz)	VBW Setting
1	802.11b	97.94	8.26	0.12	300Hz
1	802.11g	87.04	1.36	0.73	1KHz
1	802.11n HT20	86.57	1.28	0.78	1KHz



802.11b

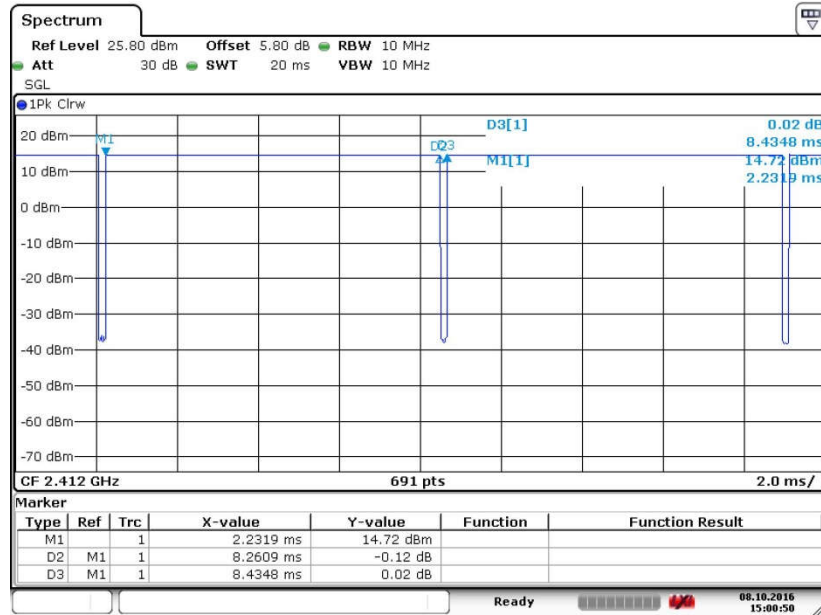

Date: 8.OCT.2016 15:00:50

802.11g

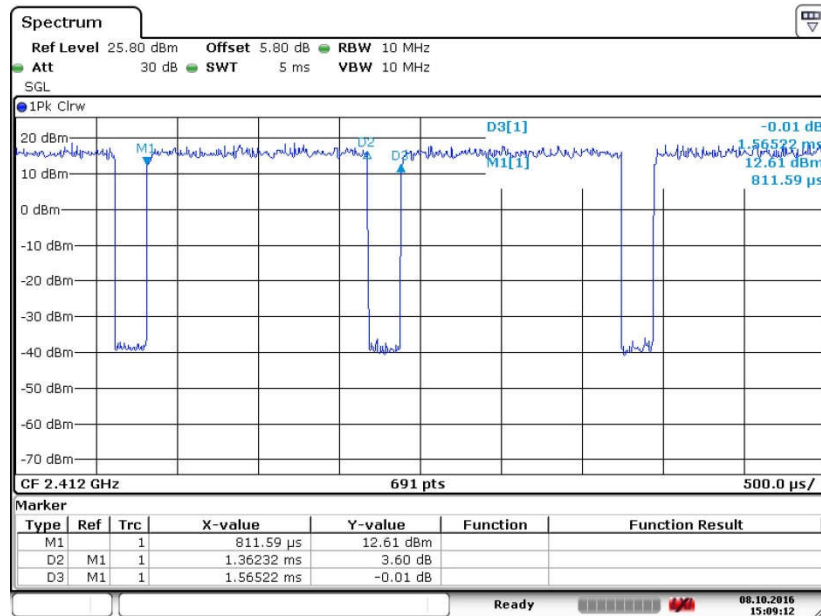

Date: 8.OCT.2016 15:09:12



802.11n20

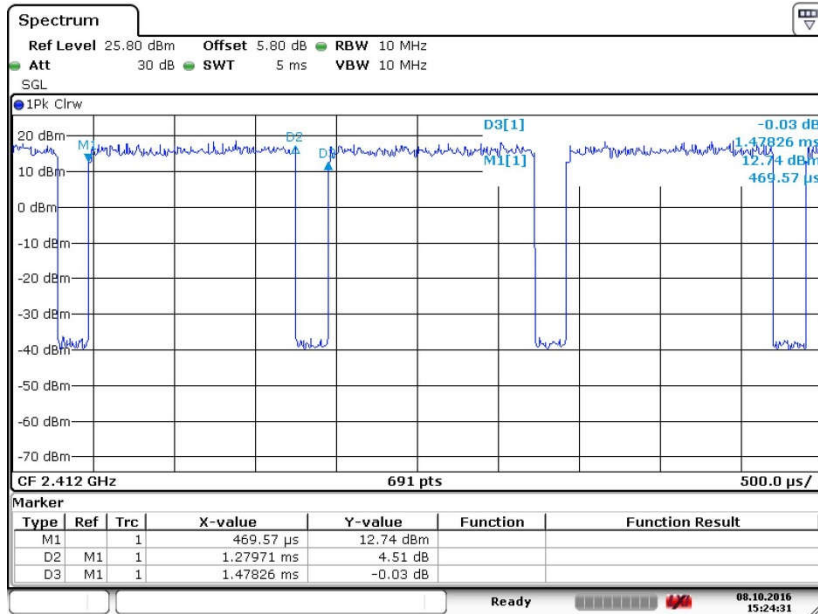

Date: 8.OCT.2016 15:24:31