

INSTRUCTION MANUAL

A preliminary draft copy of the Users Manual follows. RF exposure information is located in section 1.3.

D15 - Developer Guide - 1st draft

1. Introduction

Product description
The D15 model
Main application
SAR Requirements.

2. Installation

Mechanical description
Connections

3. Pin description & main Functionality

Pin description of connectors per model
Different communication & application

4. Modes of Operation

On/Off process include time diagram
Voice connection
Full flow control data call
Soft GSM Operation

5. Design Consideration

Power supply
Antenna
Data level (VOH, VOL)
Flex cable & external SIM Connector
Environmental

6 Testing & service

How to test a unit in a voice call
How to test a unit in a data call
How to test a unit in a soft GSM call
How to test RF features
Desense test

7. Appendix

1st. Specification
2nd. A list of AT command
3rd. Desense test

1. Introduction

1.1 **Product Specification** - See in Appendix bellow.

To add a note thal all the Data/Audio/SIM signals are compatible with D10

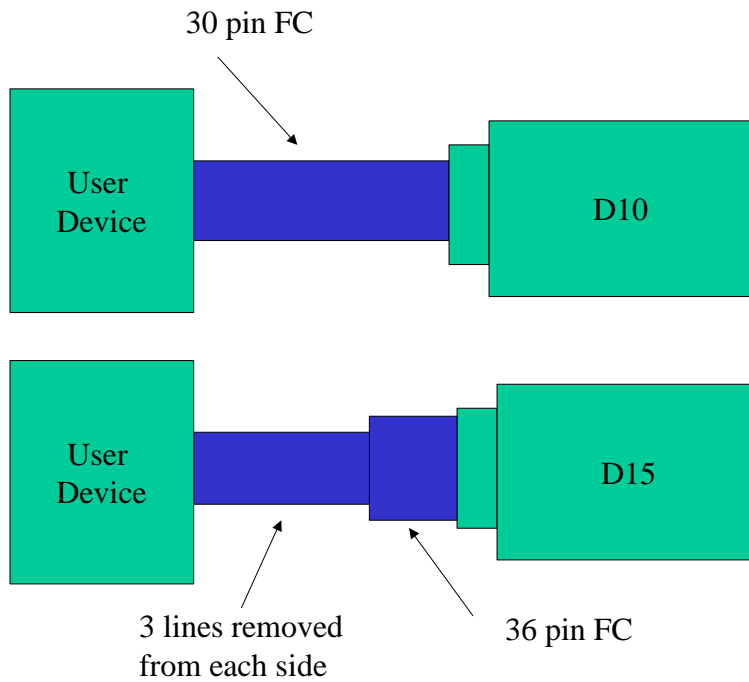

1.2 D15 Models:

- D15 DV (DV= Data & Voice) Standard.



- D15 DV Slim



- D15 DVG Slim (DVG= Data, Voice, GPS)



- D15 DV Board only (Vertical version & Horizontal version)

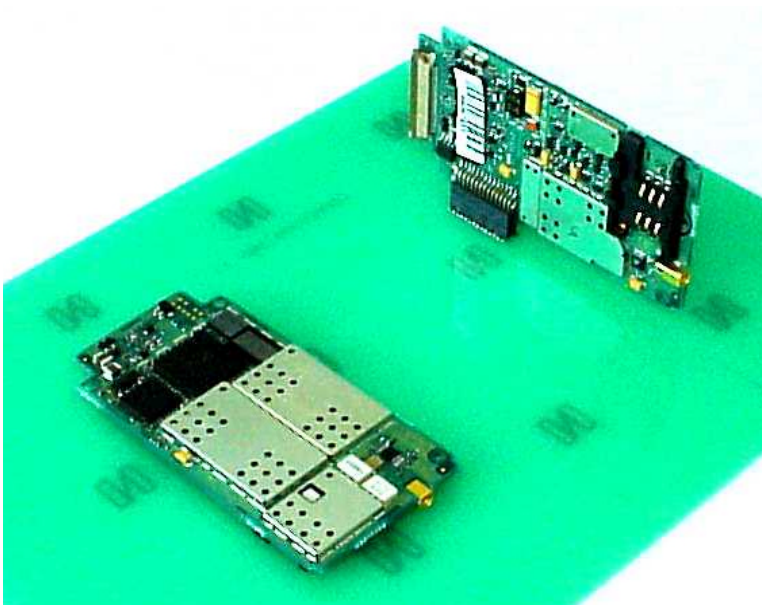

1.3 SAR Requirements

User Operation

Do not operate your telephone when a person is within 8 inches (20 centimeters) of the antenna. A person or object within 8 inches (20 centimeters) of the antenna could impair call quality and may cause the phone to operate at a higher power level than necessary and expose that person to RF energy in excess of that established by the FCC RF Exposure Guidelines.

IMPORTANT

The telephone must be installed in a manner that provides a minimum separation distance of 20 cm or more between the antenna and persons to satisfy FCC RF exposure requirements for mobile transmitting devices.

Antenna Installation

IMPORTANT:

To comply with the FCC RF exposure limits and satisfy the categorical exclusion requirements for mobile transmitters, the following requirements must be met:

1. A minimum separation distance of 20 cm must be maintained between the antenna and **all** persons.
2. The transmitter effective radiated power must be less than 3.0 Watts ERP (4.9 Watts or 36.9 dBm EIRP). This requires that the combination of antenna gain and feed line loss does not exceed 16 dBi.

2. **Installation** - See details in PRD.

Configuration 1 with d10 mounting

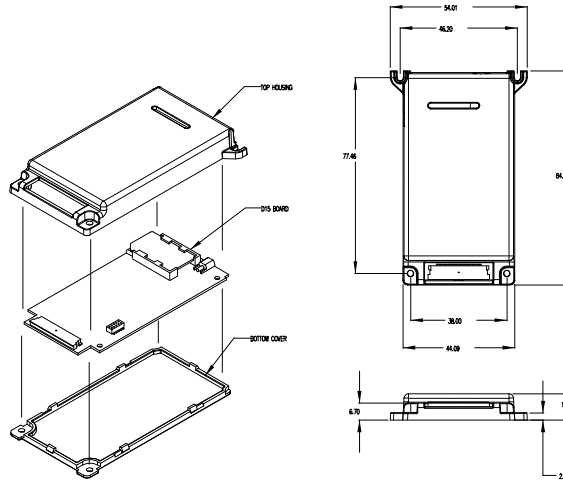

Configuration 1 with narrower mounting

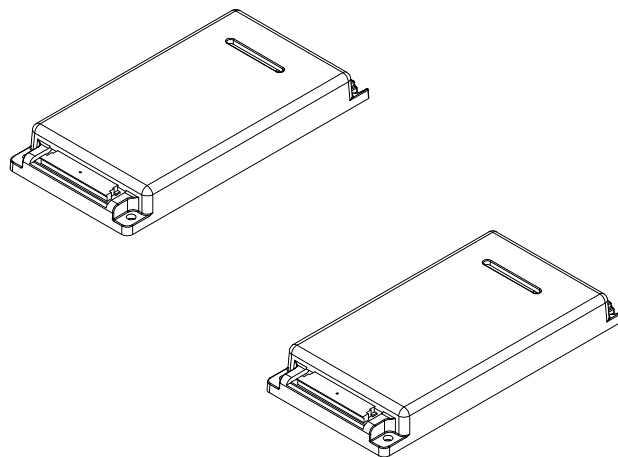

Configuration 1 with narrower mounting

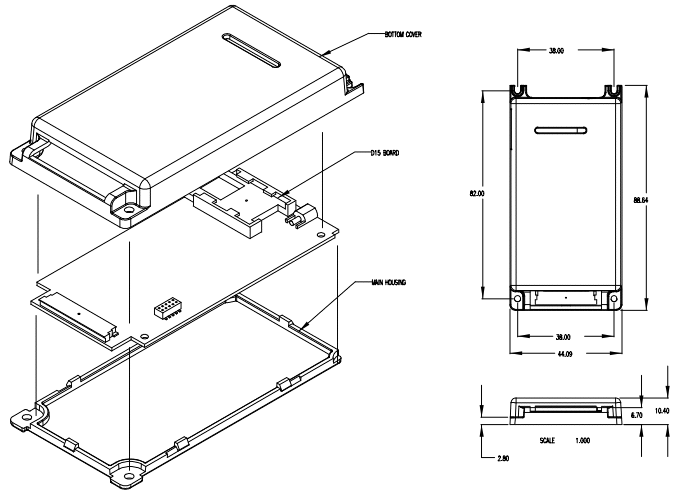

Configuration 2

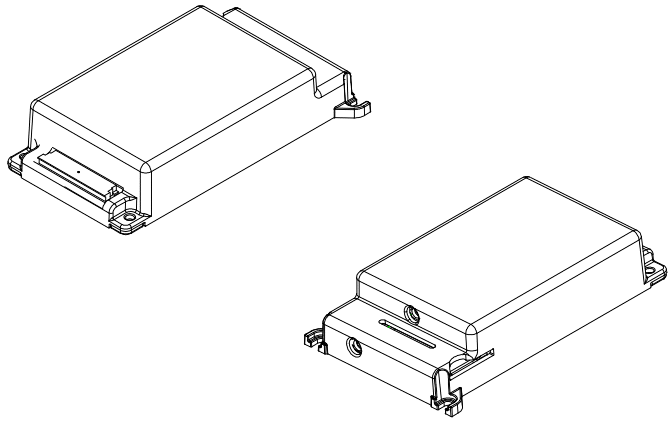

Configuration 2

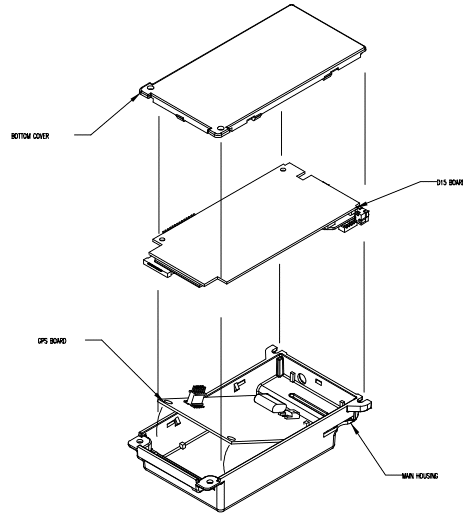

Configuration 2

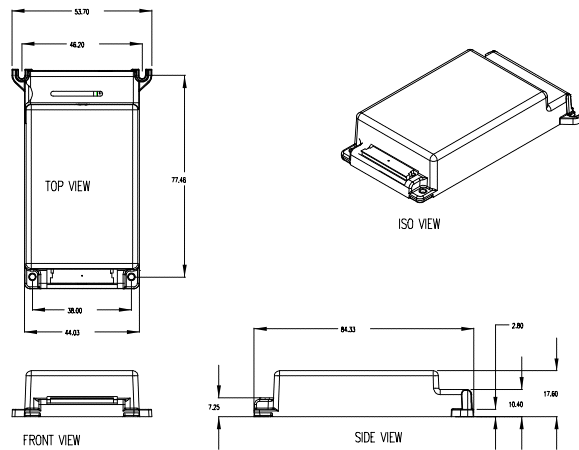

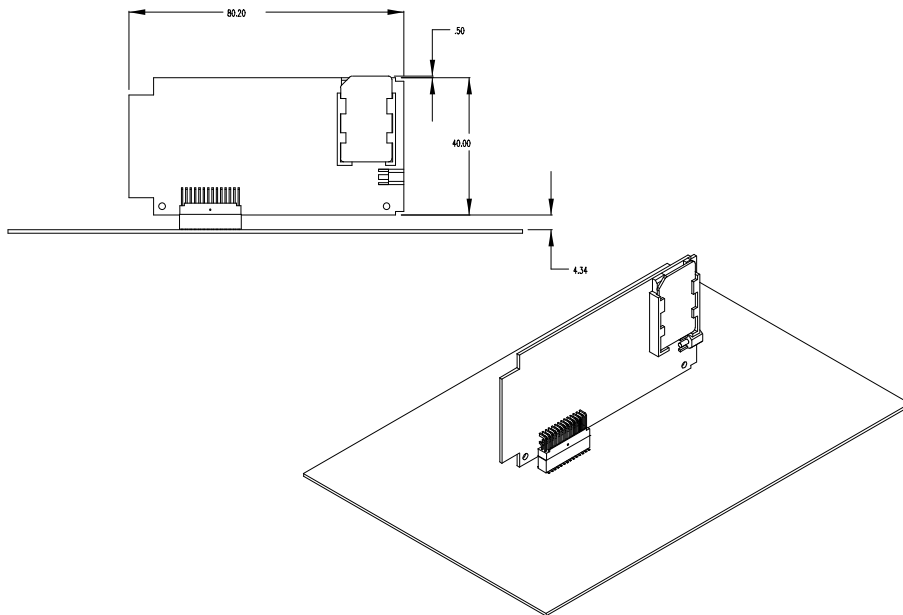

3. Pin description & main Functionality

3.1 Standard model & Slim model

The available functionality in these models are the follow:

Data & Voice (D10 Replacement & Slim) - Connections

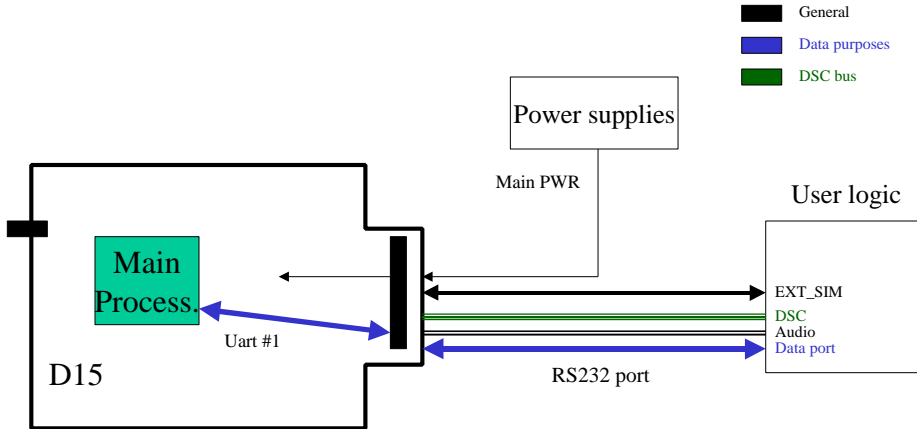

3.1.1 Function available in the user connector - 36 pin ZIF

- VCC input. 3.0 to 6Vdc
- Full RS232 - 9 pins. TXD, RXD, RTS,CTS,DSR,DTR,DCD,RI at 5V levels.
- External SIM connections. SIM Clock, SIM reset, SIM I/O, SIM VCC,SIM PD
- DSC bus. DSC_EN, Downlink, Uplink - Motorola proprietary us.
- Audio In/Out. Audio out and On/Off in the same pin, audio in Signal and analog ground.
- Man_Test line. Used to detect standard Motorola accessories.
- TS line (mobport). Used to turn on the radio.
- TX_EN line. This line is an indication when the radio is transmitting.

Note:

1. The Audio Out line is used to send out the detected audio and as a toggle On/Off pin.

2. The TS line is used to turn On the units by any transaction from Low to high in this pin.

3.1.2 Connector pin out

Pin #	Function	Pin #	Function
1	TX_EN	19	SIM I/O
2	N.U.	20	SIM CLK
3	N.U.	21	TS
4	TXD	22	DSC_EN
5	RXD	23	Down Link
6	DTR	24	Up Link
7	DCD	25	Analog Ground
8	RTS	26	Ground
9	CTS	27	Ground
10	DSR	28	Ground
11	RI	29	Ground
12	Manual_Test	30	VCC
13	Audio In	31	VCC
14	On/Off + Audio Out	32	VCC
15	N.U.	33	VCC
16	SIM_PD	34	NU
17	SIM_VCC	35	NU
18	SIM_Reset	36	NU

3.2 D15 with GPS

The available functionality in this models are the follow:

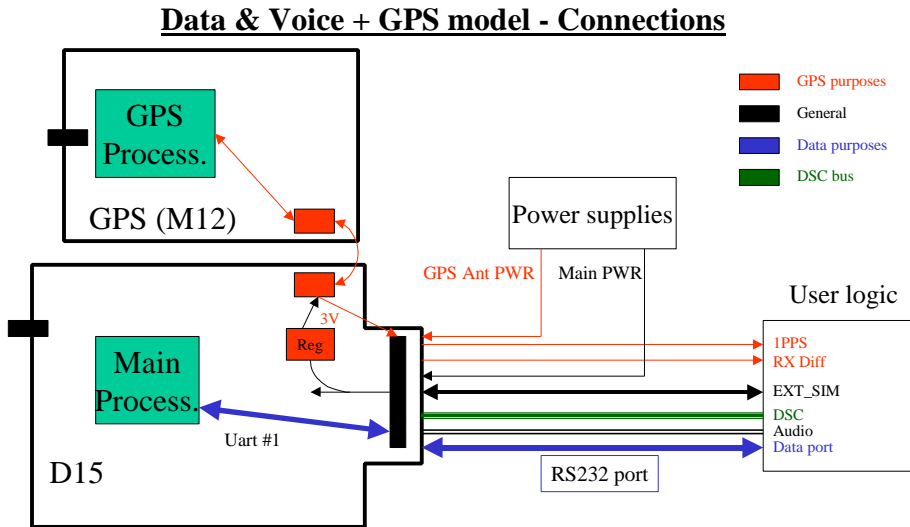

3.2.1 Function available in the user connector - 36 pin ZIF

- VCC input. 3.0 to 6Vdc
- Full RS232 - 9 pins. TXD, RXD, RTS,CTS,DSR,DTR,DCD,RI at 5V levels.
- External SIM connections. SIM Clock, SIM reset, SIM I/O, SIM VCC,SIM PD
- DSC bus. DSC_EN, Downlink, Uplink - Motorola proprietary us.
- Audio In/Out. Audio out and On/Off in the same pin, audio in Signal and analog ground.
- Man_Test line. Used to detect standard Motorola accessories.
- TS line (mobport). Used to turn on the radio.
- TX_EN line. This line is an indication when the radio is transmitting.
- GPS TXD & RXD in 3V levels, 1PPS,

RTCM, Antenna power

Note:

1. The Audio Out line is used to send out the detected audio and as a toggle On/Off pin.
2. The TS line is used to turn On the units by any transaction from Low to high in this pin.
3. The GPS is mounted on top of the D15 and receive power from the D15 but it is a stand-alone unit. The GPS is working from 3V and the RXD/TXD lines are working in 3V levels as well. The GPS receiver used is M12 (Motorola).

3.2.2 Connector pin out

Pin #	Function	Pin #	Function
1	TX_EN	19	SIM I/O
2	GPS RXD (out)	20	SIM CLK
3	GPS TXD (in)	21	TS
4	TXD	22	DSC_EN
5	RXD	23	Down Link
6	DTR	24	Up Link
7	DCD	25	Analog Ground
8	RTS	26	Ground
9	CTS	27	Ground
10	DSR	28	Ground
11	RI	29	Ground
12	Manual_Test	30	VCC
13	Audio In	31	VCC
14	On/Off + Audio Out	32	VCC
15	N.U.	33	VCC
16	SIM_PD	34	GPS Antenna Voltage 3/5 Vdc
17	SIM_VCC	35	RX for diff. GPS RTCM
18	SIM_Reset	36	GPS lpps

3.3 D15 in DIN Models (Vertical & Horizontal)

The available functionality in this models are the follow:

Data & Voice in DIN configuration- Connections

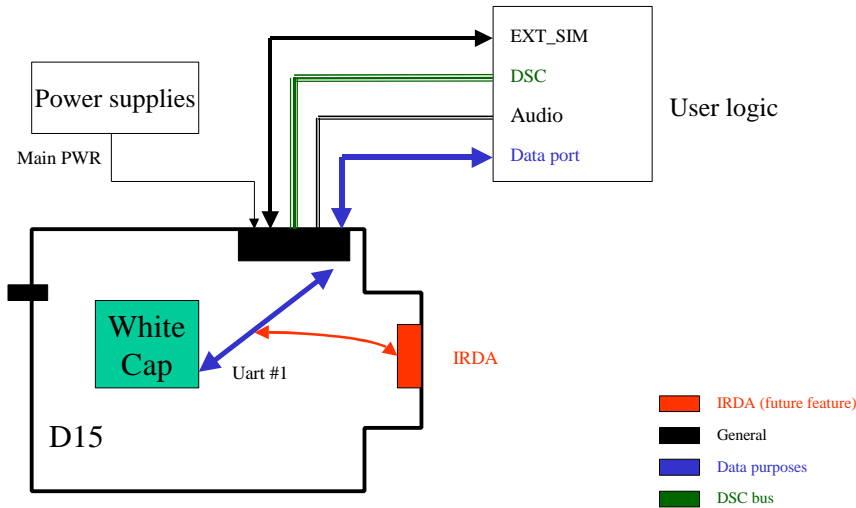

3.3.1 Function available in the user connector -

- 28 R/A Male header (vertical model)
- 28 pin Female sockets, receptacle (Horizontal model)

- VCC input. 3.0 to 6Vdc
- Full RS232 - 9 pins. TXD,RXD,RTS,CTS,DSR,DTR,DCD,RI at 5V levels.
- External SIM connections. SIM Clock, SIM reset, SIM I/O, SIM VCC,SIM PD
- DSC bus. DSC_EN, Downlink, Uplink - Motorola proprietary us.
- Audio In/Out. Audio out and On/Off in the same pin, audio in Signal and analog ground.
- Man_Test line. Used to detect standard Motorola accessories.
- TS line (mobport). Used to turn on the radio.
- TX_EN line. This line is an indication when the radio is transmitting.

3.3.2 Connector pin out

Pin #	Function	Pin #	Function
1.	EXT. B+ (3.5 to 6V)	15.	NU
2.	EXT. B+ (3.5 to 6V)	16.	TX_EN
3.	SIM I/O	17.	Analog GND
4.	*SIM_RST	18.	Audio Out+ On/Off
5.	SIM VCC (3/5 Volt)	19.	Audio In (Mic)
6.	SIM PD	20.	DSC_EN
7.	DTR	21.	DSR
8.	TS	22.	Down Link
9.	Manual Test	23.	Up Link
10.	IRDA / RS232 Select	24.	SIM_CLK
11.	GND	25.	TXD_U1
12.	GND	26.	RXD_U1
13.	RI	27.	CTS
14.	DCD	28.	RTS

Note:

1. The Audio Out line is used to send out the detected audio and as a toggle On/Off pin.
2. The TS line is used to turn On the units by any transaction from Low to high in this pin.

4. Modes of Operation

4.1 **Turn On/Off the unit.**

The D15 is powered from a single power supply in the range of 3.0 to 6.0 Vdc.

The unit will not power up automatically by connecting the power and there are two ways to turn the unit On.

4.1.1 **Turn On/Off the unit using the ON/OFF pin.**

The On/Off pin (pin no' 14 at the ZIF connector & pin no' 18 at the DIN connector) is used as a toggle input to turn On and Off the unit. Any drop to ground in this pin will change the status.

To verify that the unit is On or Off you have to check the DSC_EN line, If it is high the unit is On If it is low the unit is Off.

The timing for this process are the follow:

Turn On the unit using the ON/OFF pin

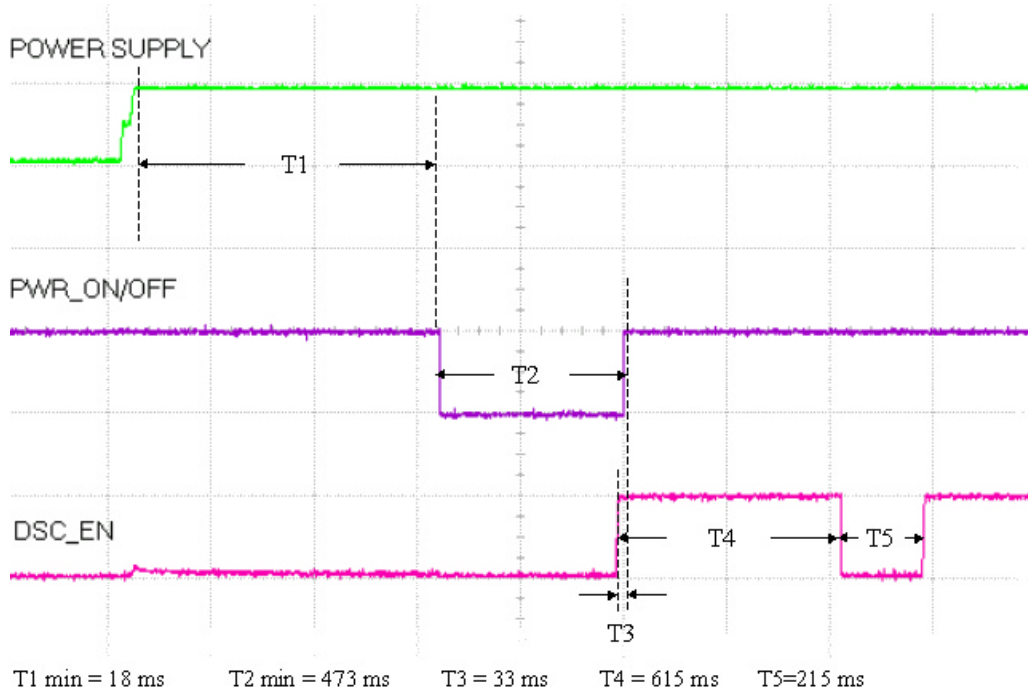

Turn On and Off the unit using the ON/OFF pin

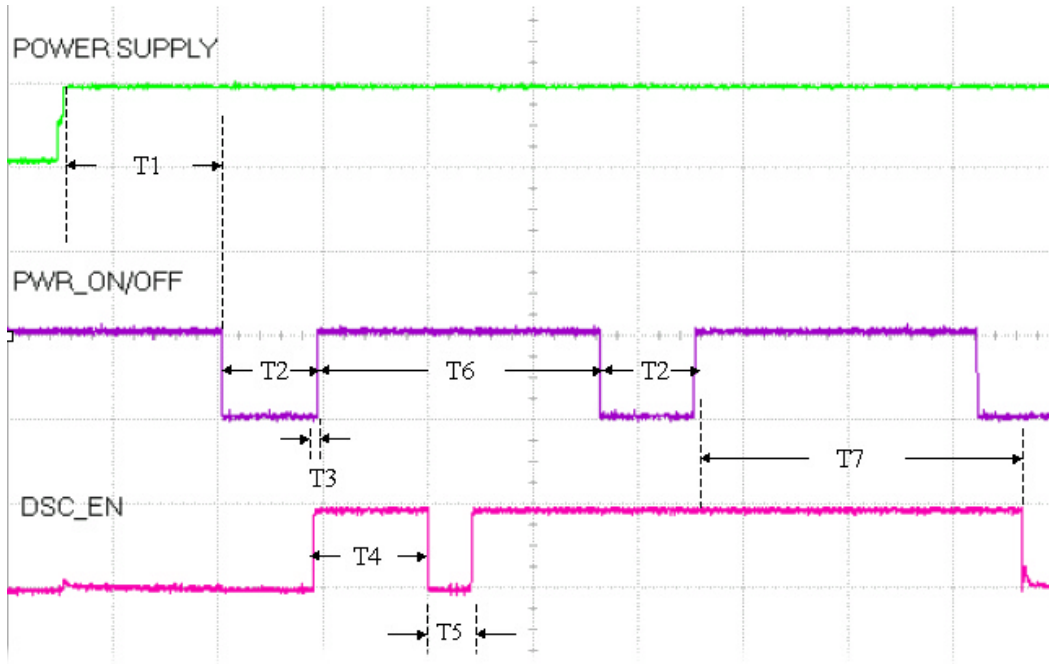

T1 min = 18 ms T2 min = 473 ms T3 = 33 ms T4 = 615 ms T5 = 215 ms
T6 min = 1.1sec T7 = 2.65 sec

4.1.2 Turn On the unit using the TS pin.

The main used of the TS line is for units connected to a mobile device in witch the current consupction is not the main consern.

The TS line is used to turn On the unit. This line can't turn Off the unit.

When this line is rised up it will turn On the unit.

This line is used for example to turn On the unit when power is connected to the unit. (Like Ignition line in a car kit).

Be aware that if you keep this line high all the time the unit will not go to Sleep mode (current save mode), So it is recommended to turn On the unit and than drop this line.

Turn On the unit using the TS line

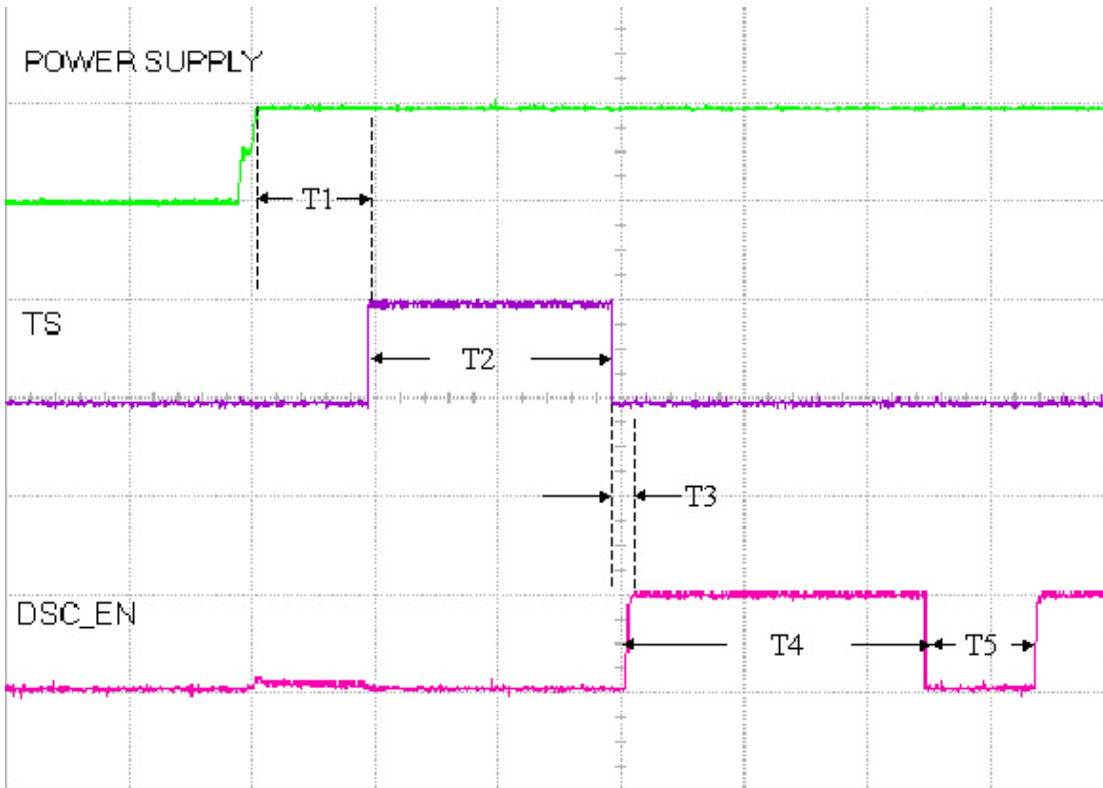

T1 min = 0 T2 min = 473 ms T3 = 32 ms T4 = 615 ms T5 = 215 ms

4.2 Data connectivity.

To clarify the Data connectivity and the direction of the signal see the follow diagram:

All the signals in the user connector are 0 to 5V.

When the control lines (RTS, DTR, DCD, CTS, DSR, RI) active is low (0V) and unactive is high (5V).

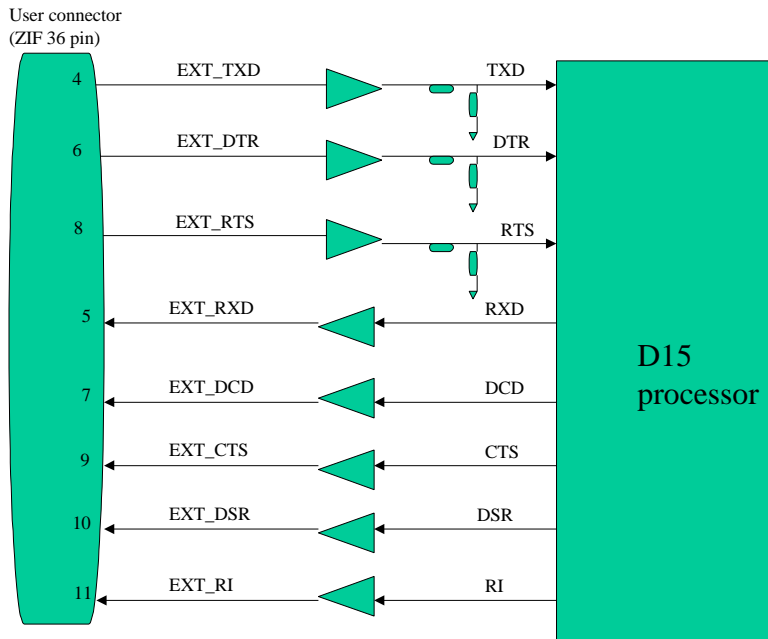

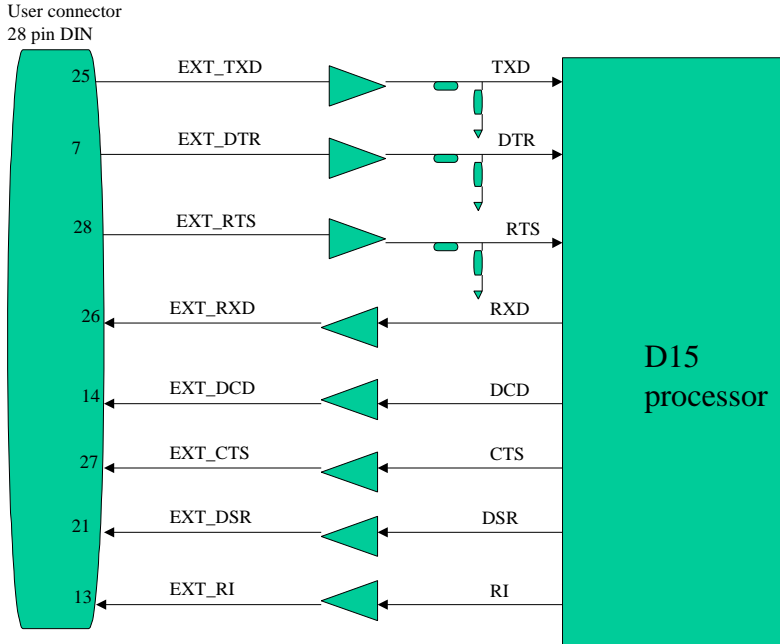

There are two modes to use the Data port:

- SoftGSM mode. This mode is for computer application in which an application SW "SoftGSM" is used. This allowed the D15 to work with V42.bis (data compression), transfer fax and SMS.
- RS232 full flow control. This is the default setting for the D15. In this mode we can transfer data and SMS using a full flow control (HW flow control), Xon/Xoff or non flow control.
There is now FAX capability in this mode.

4.2.1 Using the SoftGSM.

4.2.1.1 SoftGSM Selection

The selection of SoftGSM is done by Hardware in the user application.

In order to switch to this mode the user need to connect pulldown resistors of 22Kohm in the Downlink line (pin no'23 in the zif connector or pin no'22 in the 28 pin) and the DCS_EN line (pin no'22 in the zif connector or pin no'20 in the 28 pin).

In this mode the necessary lines are: TXD, RXD.

An example for the circuitry to add the pulldown resistor can be seen in Pharagraph ??? EV_board design.

4.2.1.2 File / Fax / SMS transfer in SoftGSM mode.

To Transfer a file in softGsm you need to:

1. connect the RX/TX lines of the D15 a a comm port of the computer. .(the levels should be converted to RS232 or use a EV board or equivqlent).
2. Run the SoftGsm Application in the computer.
3. The SoftGsm program will open a phone tools application.
4. Use the phone application to send/Receive file/Fax/SMS .

The activity of the required lines and timing for file transfer using SoftGsm can be seen in the following plot:

Sending / Receiving files in SoftGsm

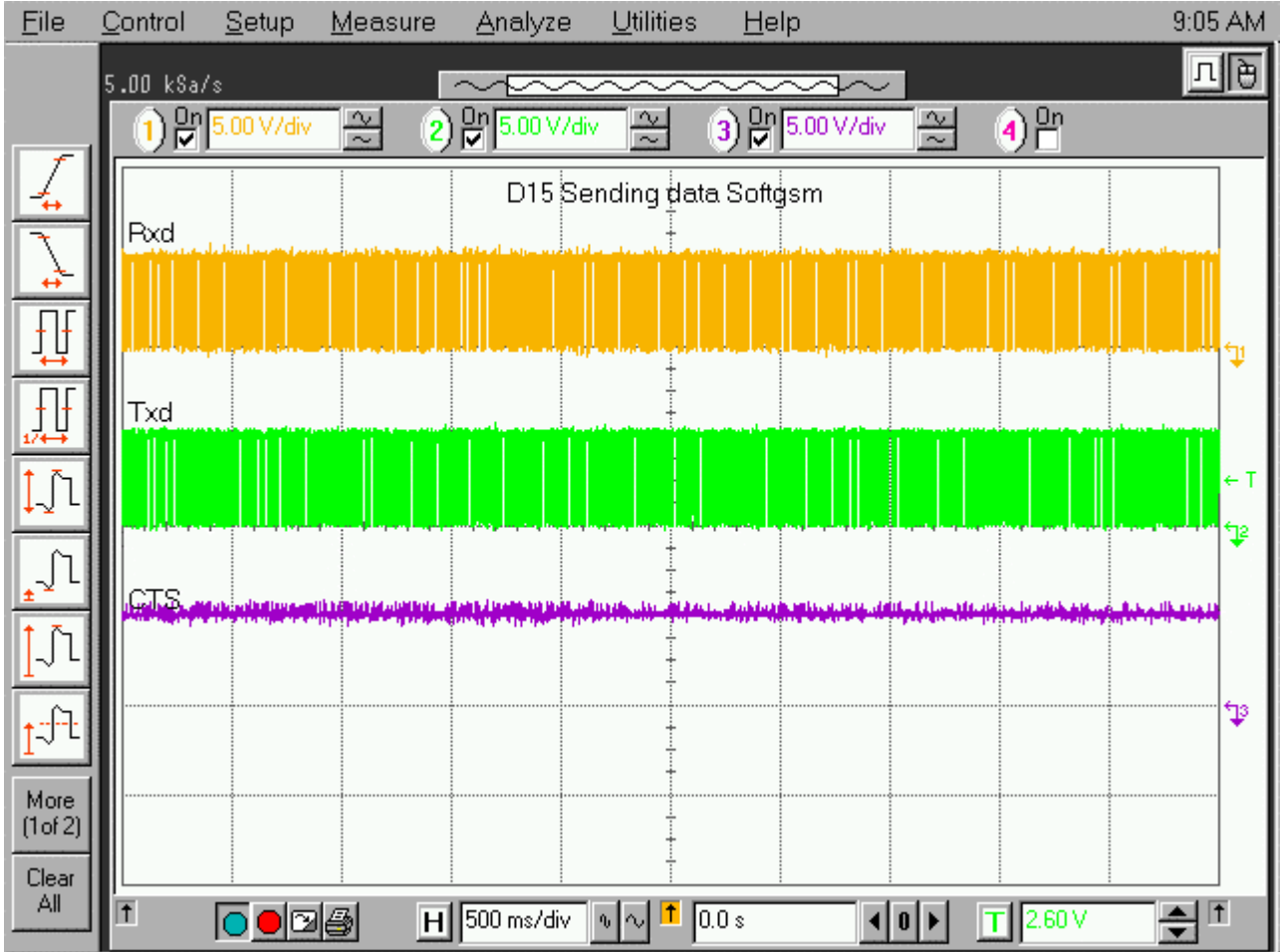

The activity of the required lines and timing for Fax transfer using SoftGsm can be seen in the following plot:

Sending / Receiving Fax in SoftGsm

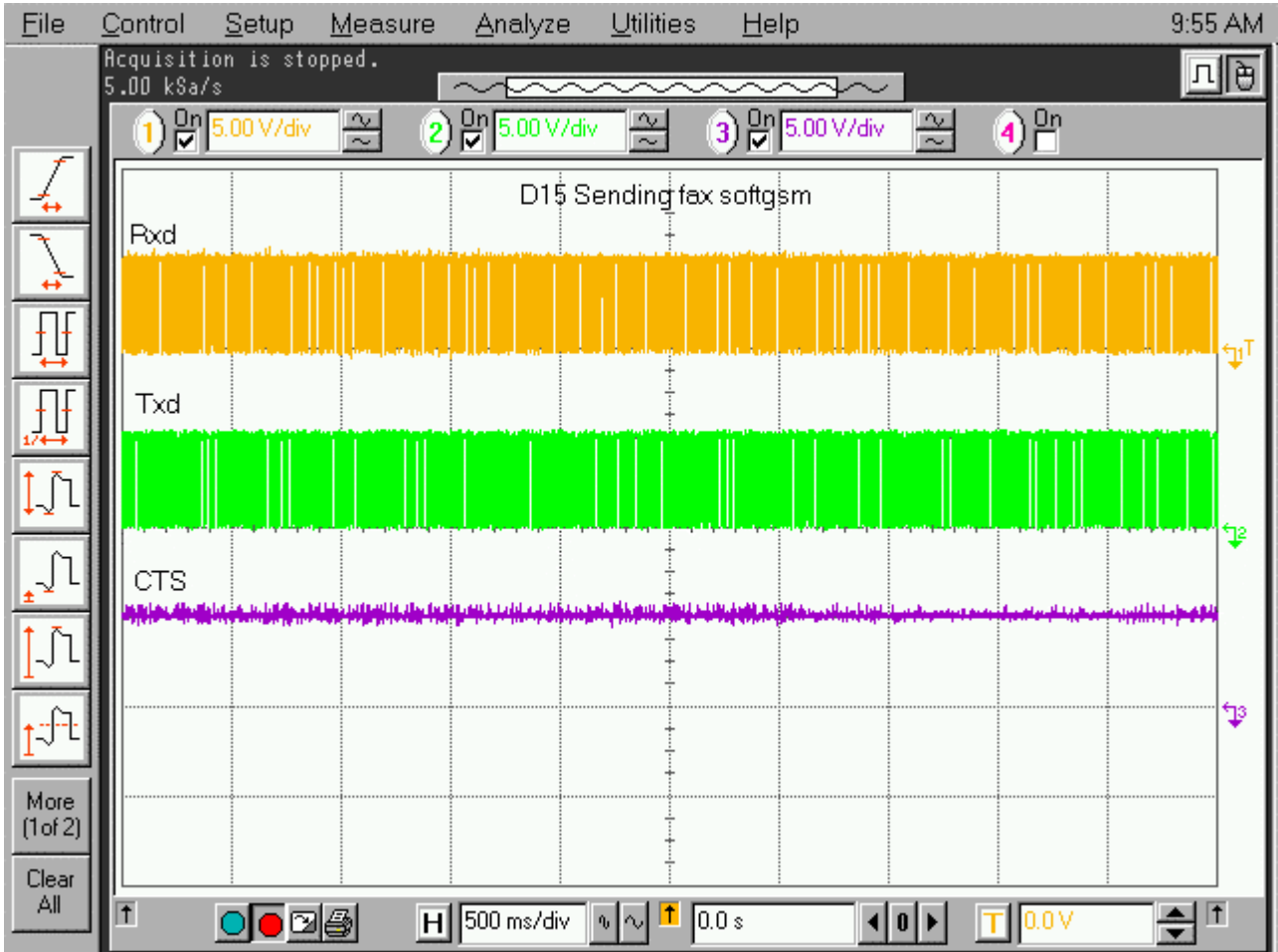

The activity of the required lines and timing for SMS transfer using SoftGsm can be seen in the following plot:

Sending / Receiving SMS PDU mode in SoftGsm

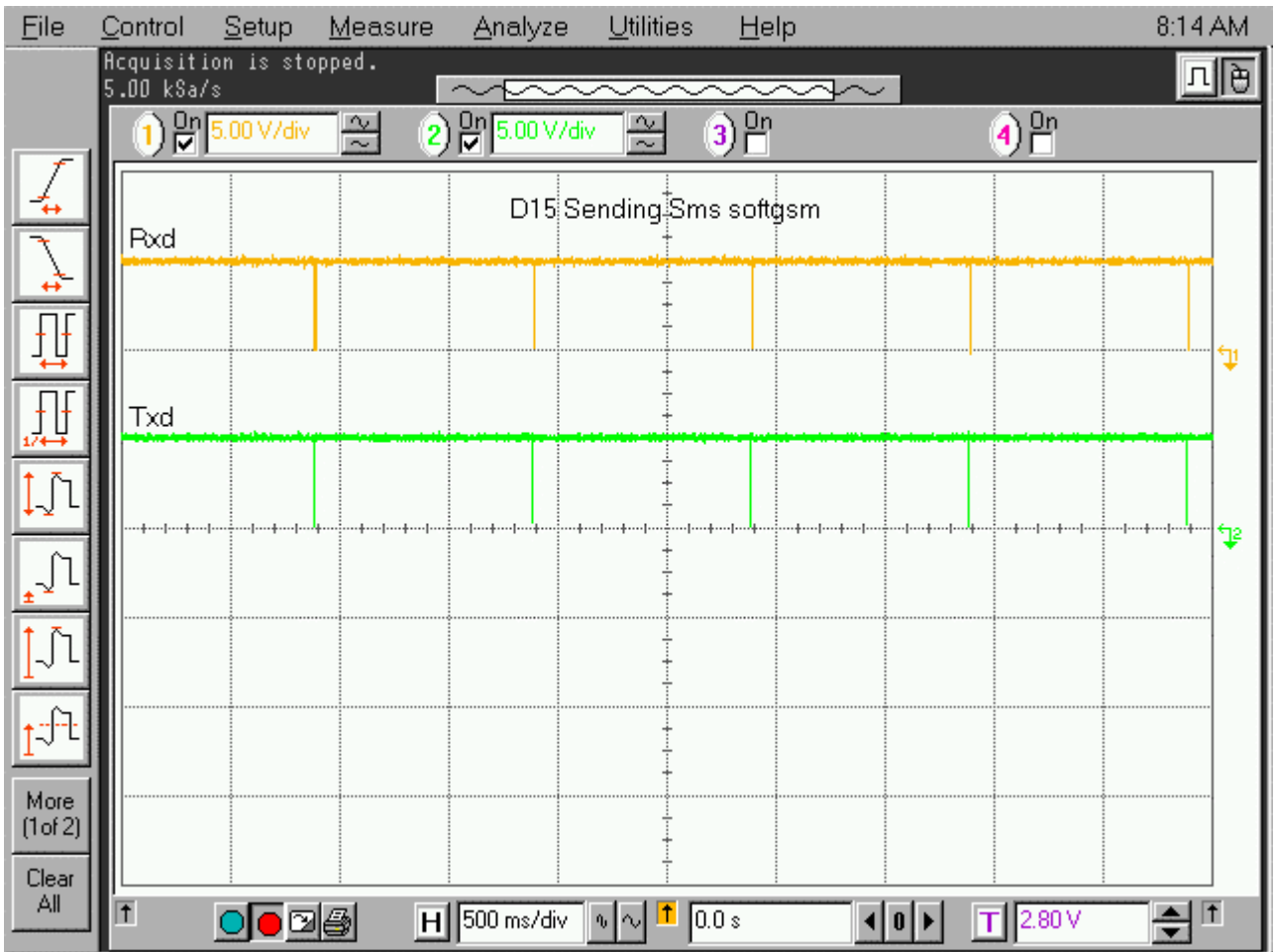

4.2.1.4 Sending / Receiving SMS block mode.

TBD

4.2.2 Using RS232.

4.2.2.1 RS232 Selection

The RS232 is the default setting in the D15 and no HW selection is needed.

The RS232 can use 3 different modes of setting to the DTE device:

HW (Hardware) flow control - all RS232 lines are used (DTR, DSR, RTS, CTS, TXD, RXD, DCD, RI, GND).

None flow control - DTR, DSR, TXD, RXD, DCD, RI, GND are required.

Xon / Xoff flow control - DTR, DSR, TXD, RXD, DCD, RI, GND are required.

4.2.2.2 work with RS232 with "sleep mode"

If the D15 will have no accessories and the unit is camped the D15 will go to a "sleep mode" (current save mode).

During this period of time the RS232 is not responding to any command from the DTE device(Uart is not activated).In order to make the unit to wake up when the DTE will like to communicate with the radio the user have two options:

1. Activate the RTS During all the DTE/DCE dialog. (Internaly the TS line will be activated). After the communication disable the RTS in order to go back to sleep mode.

2. Activate the TS During all the DTE/DCE dialog. After the communication disable the TS in order to go back to sleep mode.

4.2.2.3 File transfer in RS232 mode.

To Transfer a file in RS232 you need to:

1. connect the relevant lines depend on the mode to a comm port of the computer.(the levels should be converted to RS232 or use a EV board or equivlent).
2. Run Hyper terminal application or equivalent in the computer. (in the final application it will be the user program).
3. Select the flow control / Comm and baud rate.
4. Select the activity send/Receive file/Fax/SMS .

The diling process / signalizationn can be seen in the following diagrams:

Receiving a ring.

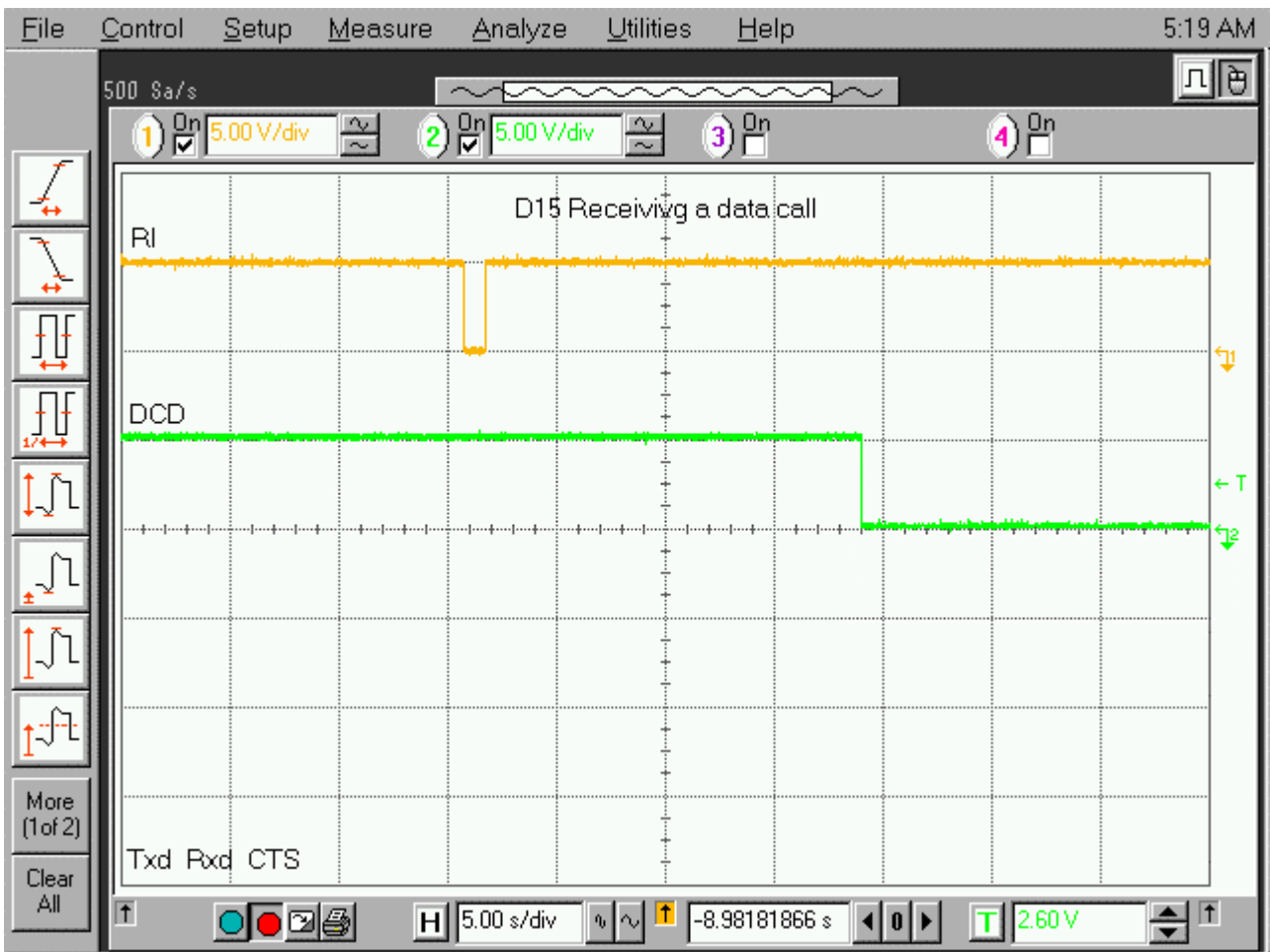

The activity of the required lines and timing for file transfer using RS232 HW flow control can be seen in the following plot:

Sending a file in HW flow control.

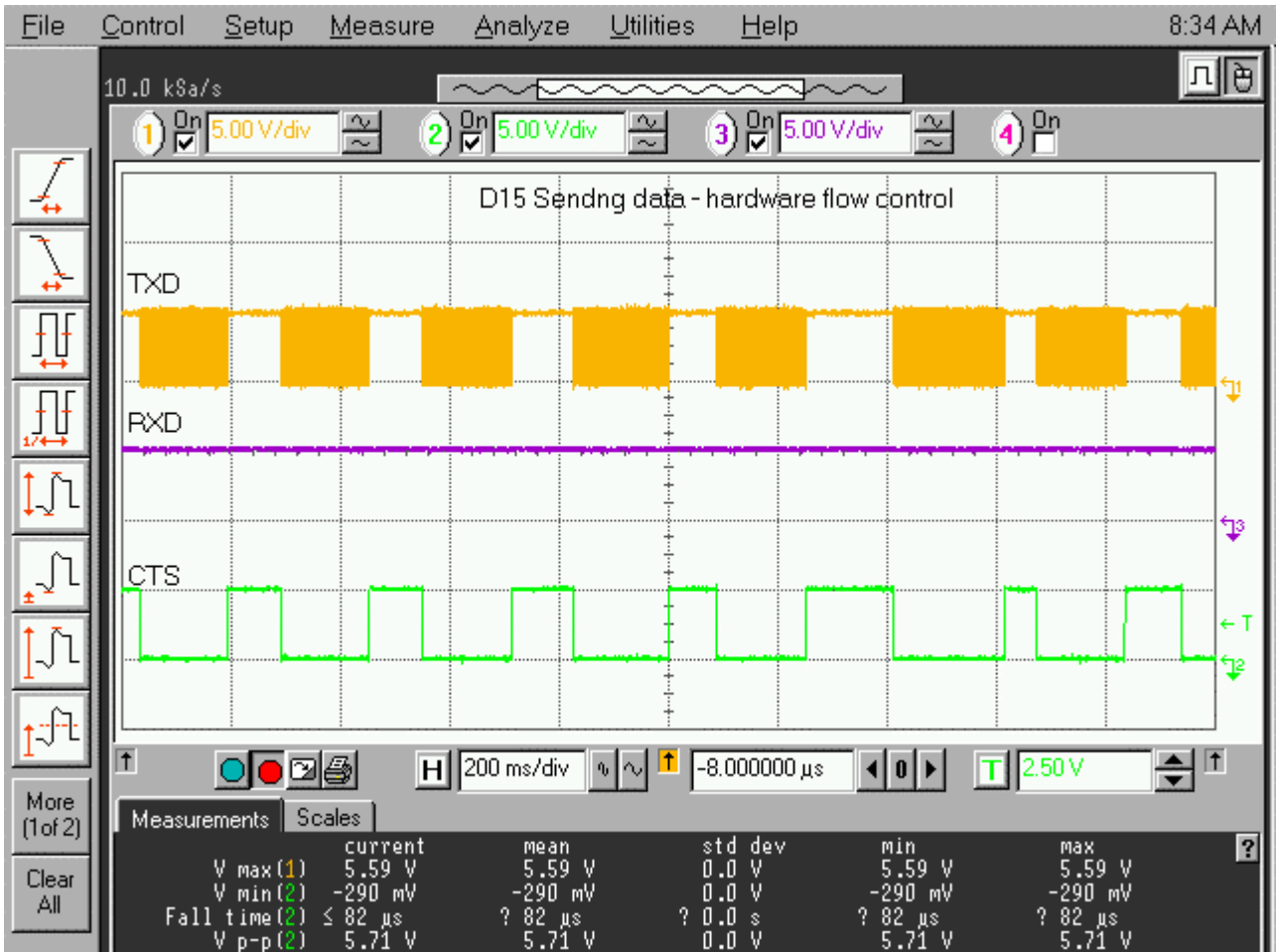

Receiving a file in HW flow control

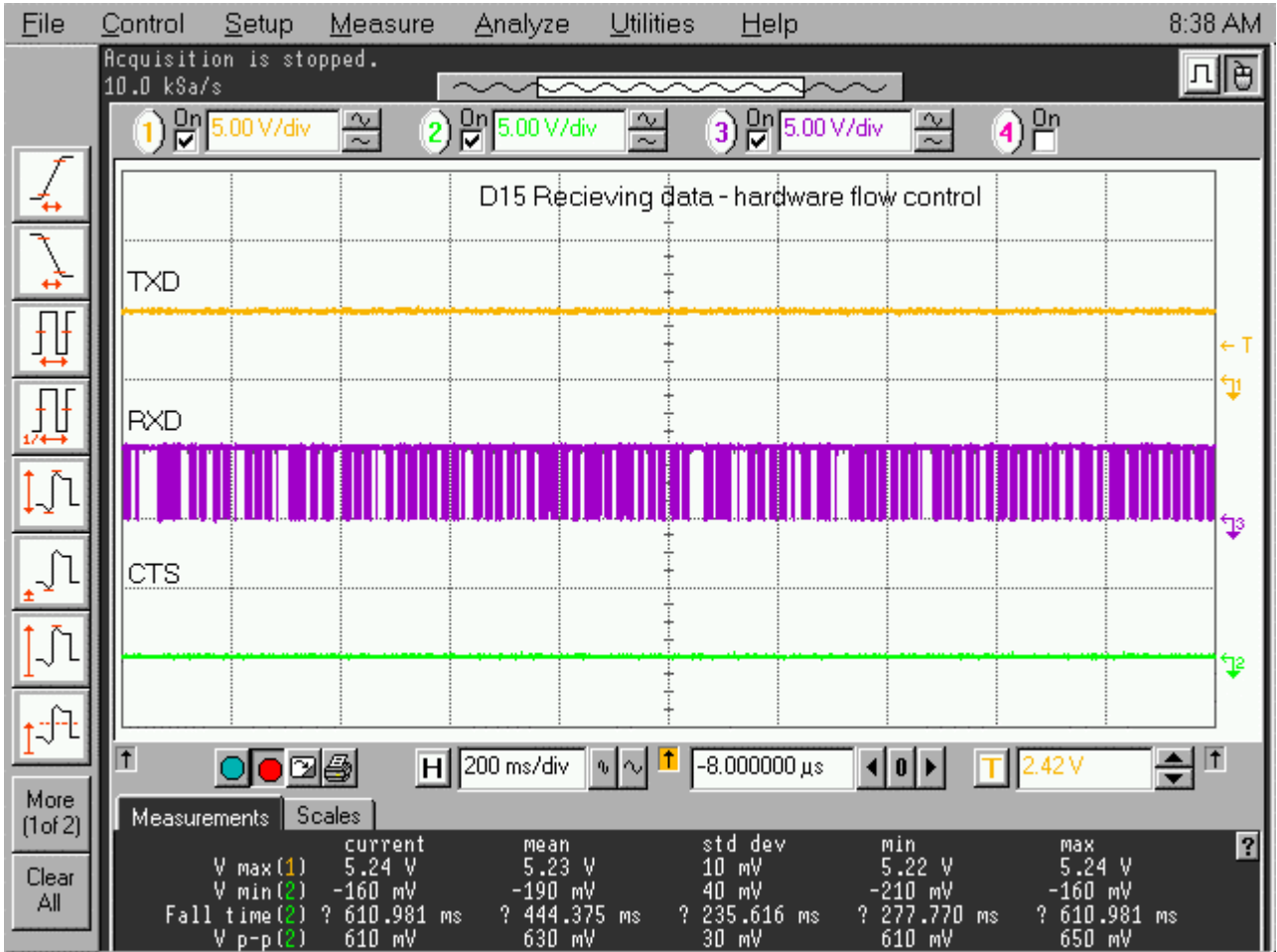

Sending a SMS in PDU mode - HW flow control.

Step 1 - preparing the data to be sent:

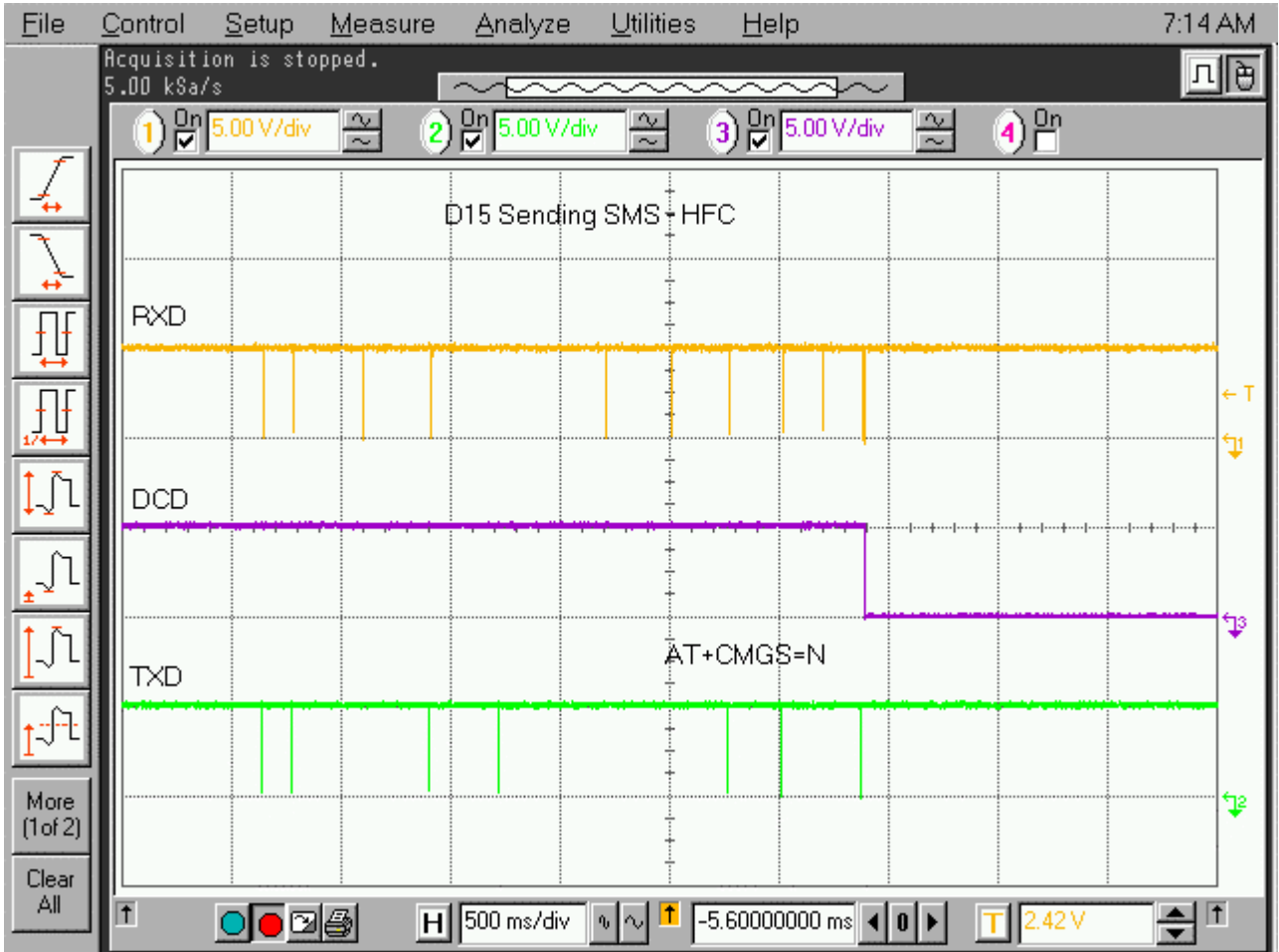

Step 2: inserting the SMS message:

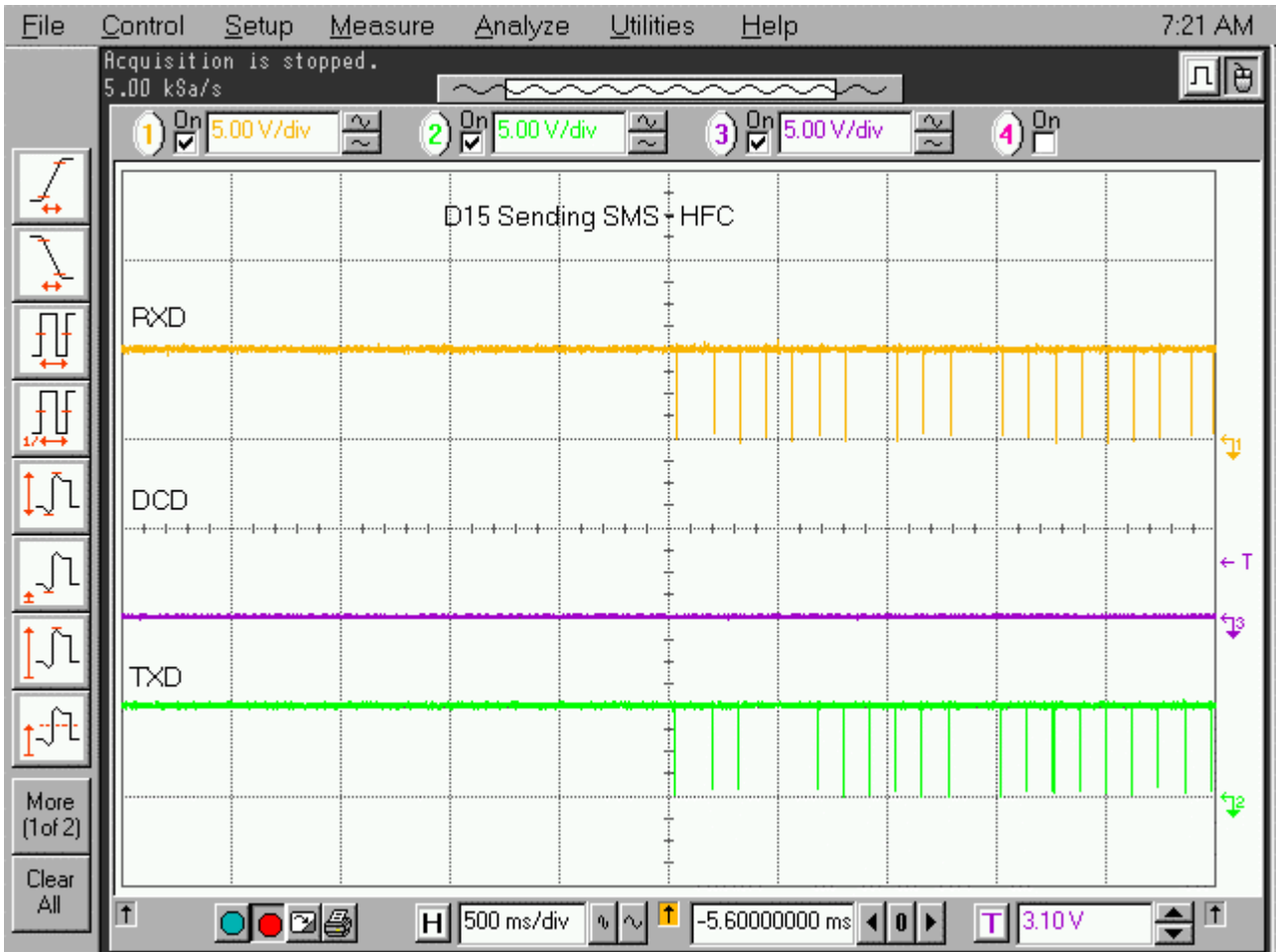

Step 3: Sending the SMS:

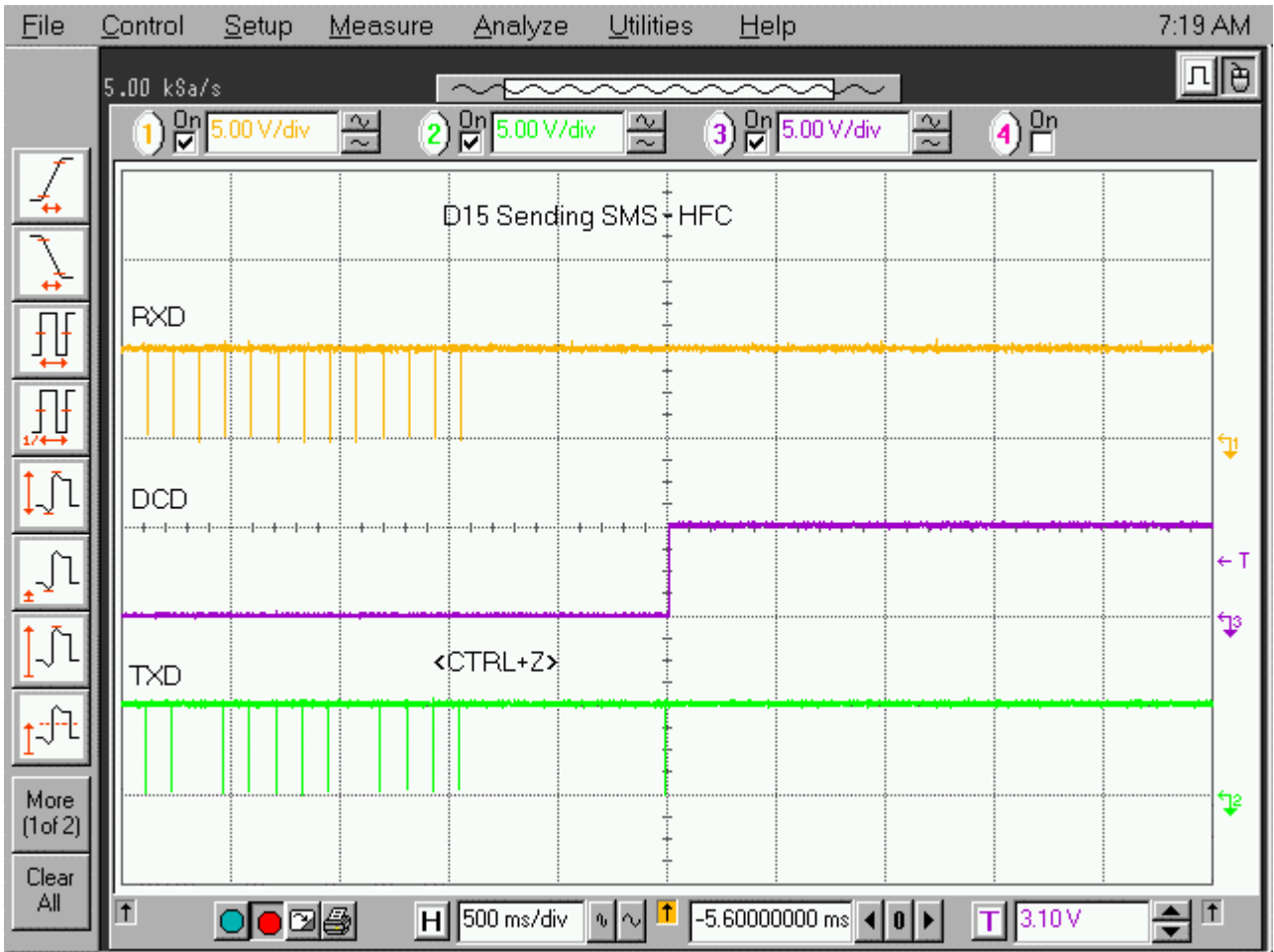

Receiving a SMS in PDU mode - HW flow control.

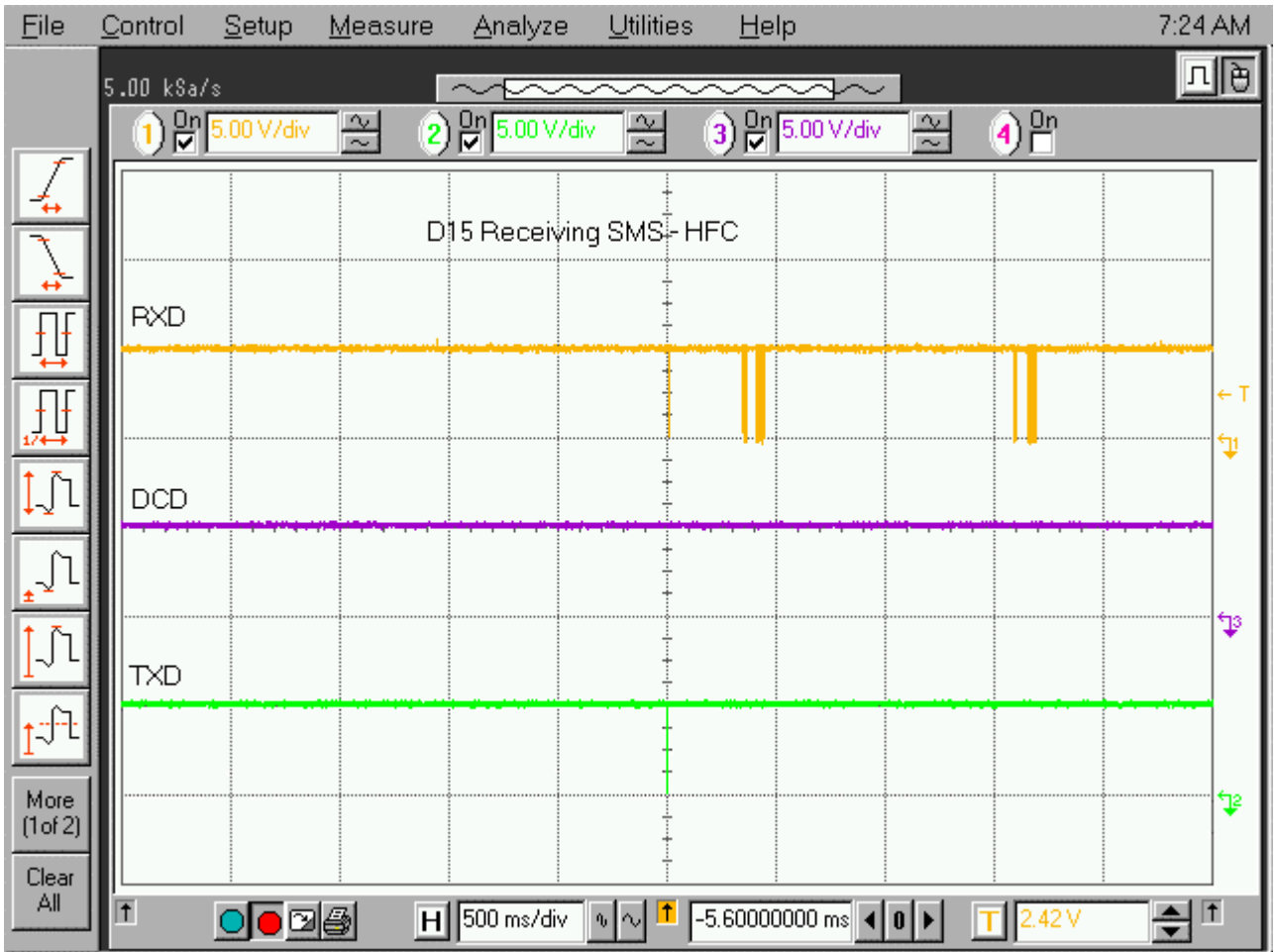

4.1.2.1 Transfer files using Xon/Xoff setting.

Sending a file n Xon / Xoff

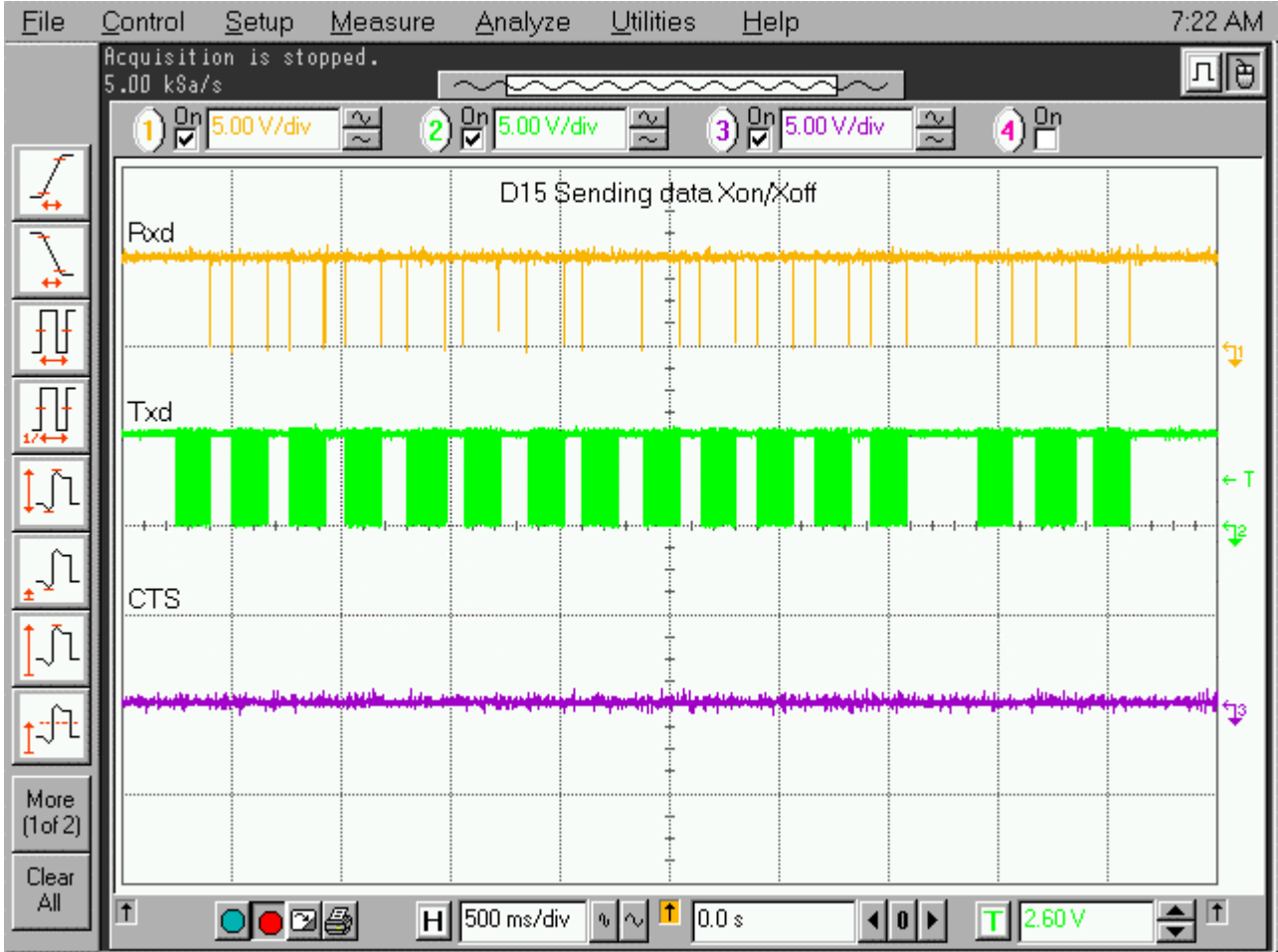

Receiving a file in Xon / Xoff

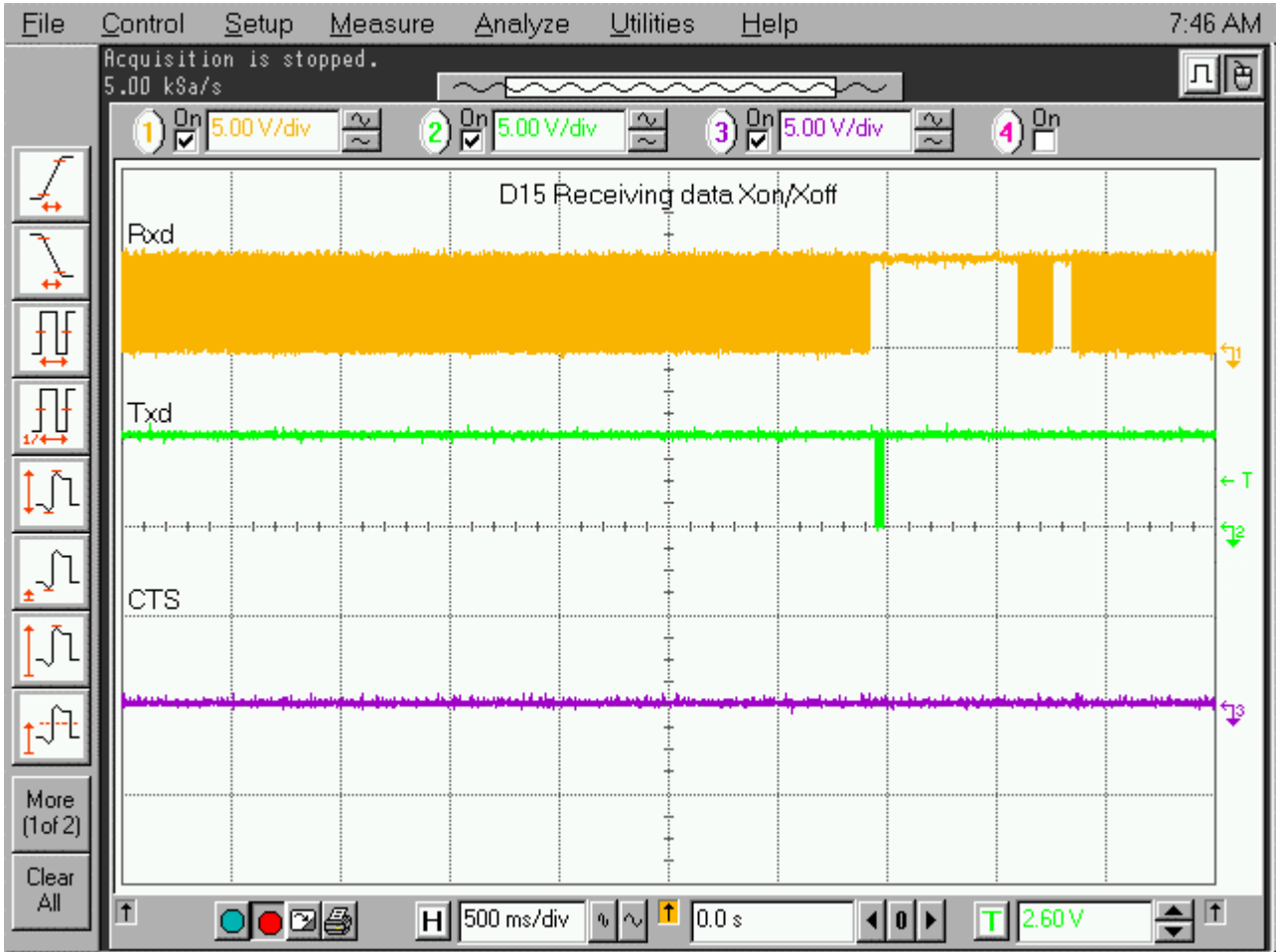

4.1.2.2 Transfer files using none setting.

Sending a file in none mode

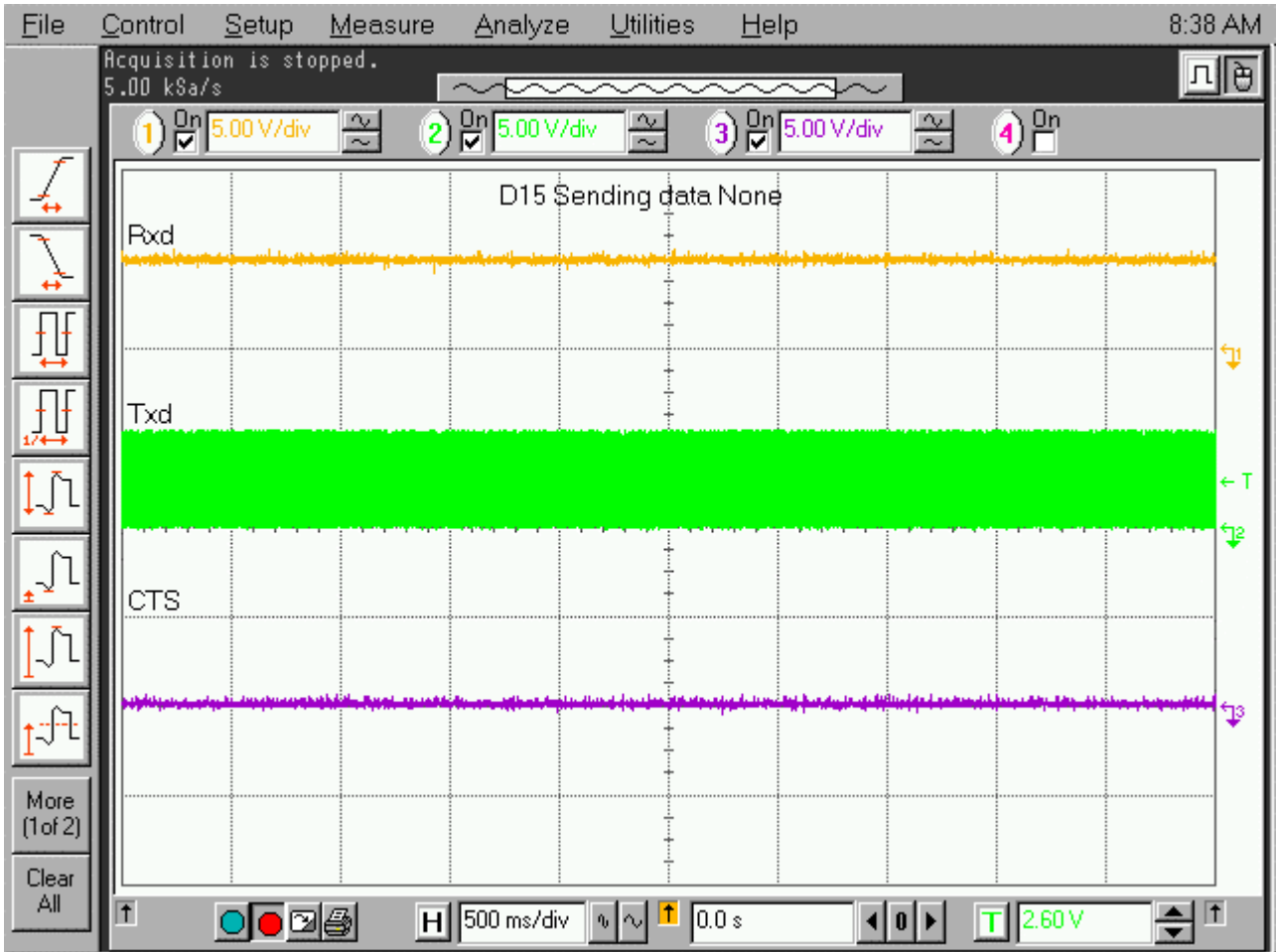

Receiving a file in none mode

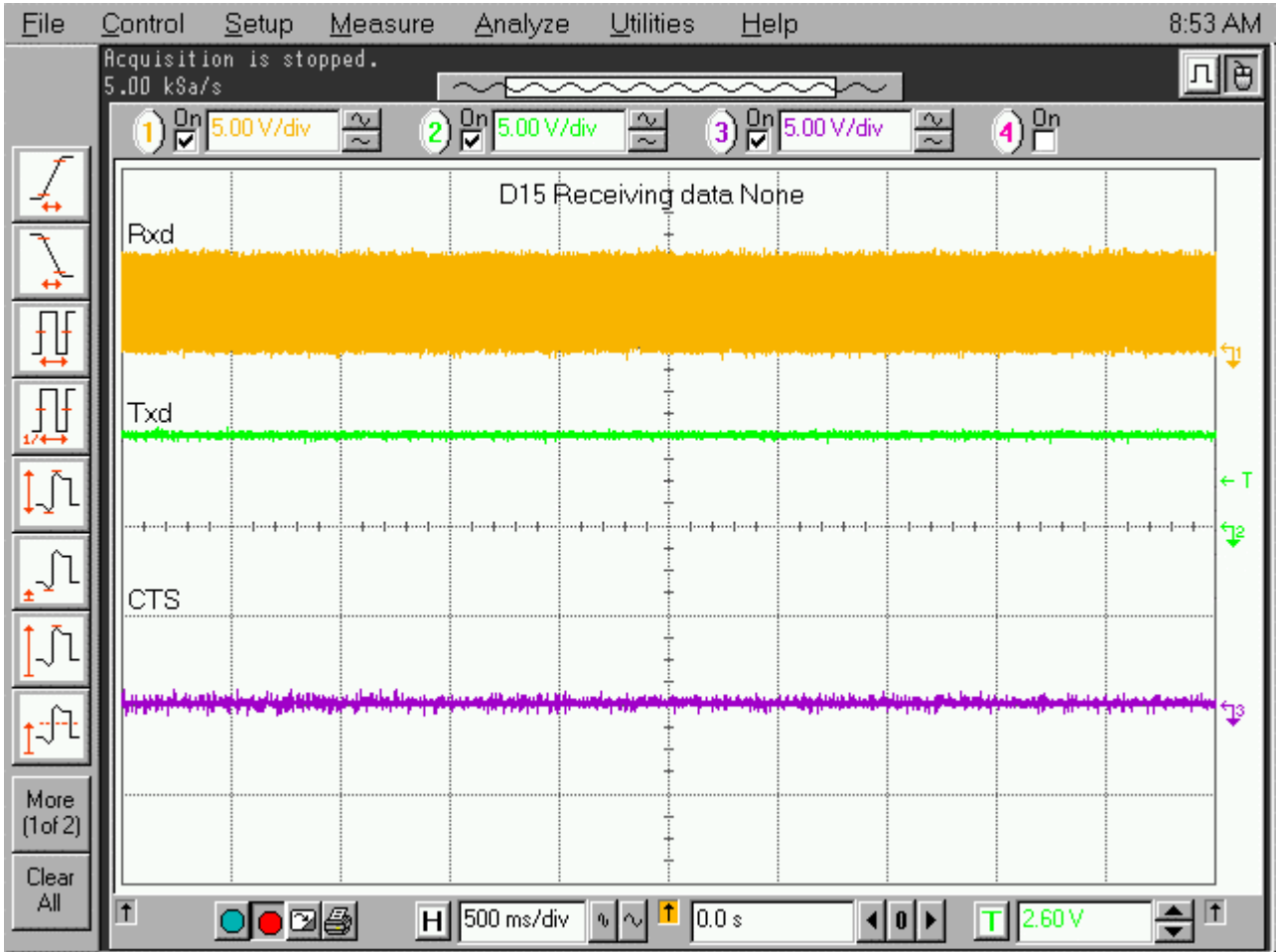

4.1.2.2 Sending/ Receiving SMS block mode.

TBD

4.3 Voice connectivity.

The D15 is an OEM Data & Voice module.
The voice connectivity can be done in two main channels -
analoge voice, Digital voice.

4.3.1 Digital voice:

The Digital voice is done using the Motorola DCS bus.
This bus is an Motorola Proprietary bus and details can be
received after an agreement.

General connections:

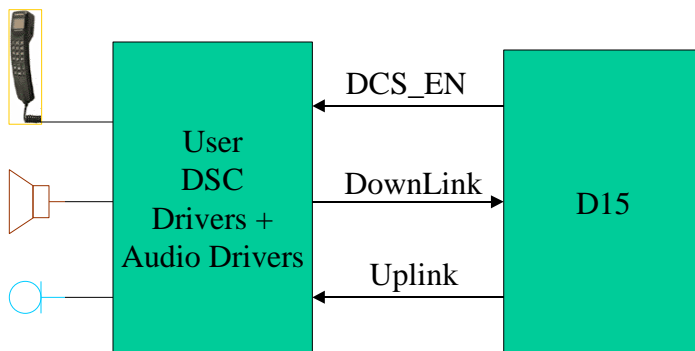

In case that the D15 is connected to a standard Motorola Car
Kit the TS line should be connected to VCC in order to turn On
the unit using the Ignition line.

4.3.2 Analog Audio.

The D15 is driving out the analog audio detected by the radio. The D15 is not including any audio drivers. The user have to include the audio drivers in is application. An example for audio drivers can be seen in the EV board appendix ??.

The D15 can provide the analog audio in two ways:

- Analog audio to by drived to an Headset - Default.
- Analog audio with Echo canceller activated - for Hands free applications.

When an Headset is used in the user application than audio drivers for the headset are needed.

When an external Speaker and Microphone are used drivers for them are required and activation of Echo canceller in the D15 DSP is required.

To activate the Echo canceller you need to type an AT command in the Data port.

ATs96=1 will activate the Echo canceller.

ATS96=0 will disable the Echo canceller.

The block diagram for the required drivers are shown below, But detailed example of drivers design you can see the Evaluation board design, Pharagraph ???.

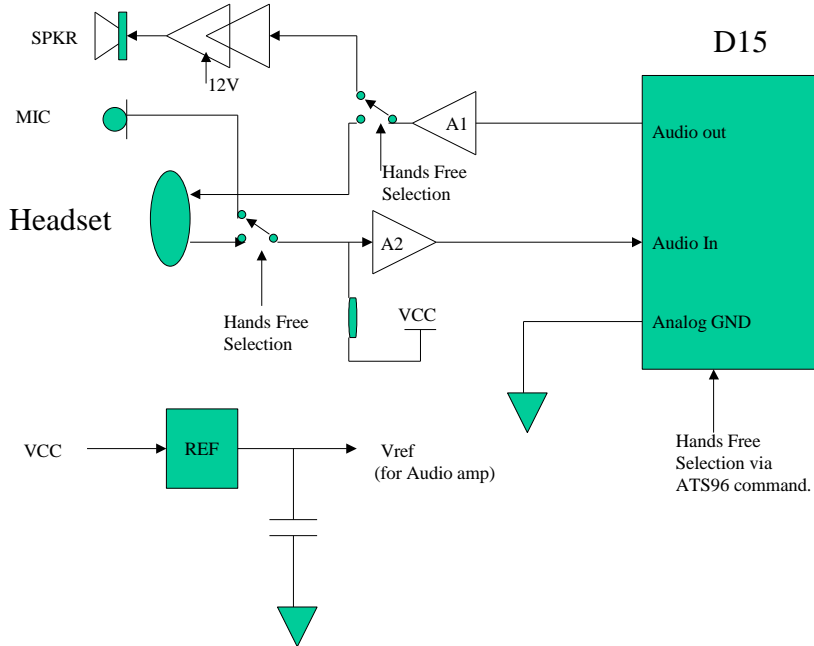

The requirements from the drivers and audio devices are the follow:

Microphone impedance:	Typical 700Ω
S/N ratio	Minimum 35dB
Gain from headset to D15 (A2)	45 - 49 dB
Frequency response (including microphone)	-11 to +1 dB 300 to 3400Hz.
D15 input impedance	10KΩ
TX Distortion	Maximum 5%.
Speakerphone Load	25 to 39W.
S/N	Minimum 35dB
Gain from D15 to Headset (A1)	-13 to -9 dB
Frequency response (including SPKR)	-10 to +1 dB 300 to 3400Hz.
D15 output impedance	<1KΩ
Distortion	Maximum 5%.

The Audio route for the different devices is described in the following table:

Configuration Setup and aAudio Routing in D15

1. **HF** Refer to External Speaker & Microphone connected.
2. **DHFA** refers to External Car kit.
3. Correct setup are in bold letters.

Configuration Setup	Audio Route to...
Off hook handset (overrides all other conditions)	Handset.
On hook handset, or absence of handset:	-
- HF + HF was selected by AT command	- HF external Speaker with Echo cancelling
- HF + HF was not selected by AT command	- HF External Speaker,W/O Echo cancelling
- DHFA	- DHFA Speaker
- Headset + HF was selected by AT command	- Headset with Echo Cancelling
- Headset + HF was not selected by AT command	- Headset W/O Echo Cancelling

5. Design Consideration

5.1 Power supply considerations. Current requirements in each mode.

5.2 Audio considerations.to refer to EV board chepter in appendix.Car Kit connectionsl.

5.3 Data port considerations & Levels.

5.4 SIM card considarations.

5.5 ESD considerations.

5.6 Antenna

5.7 Software

5.8 Mechanical

5.1 Power supply consideration.

5.1.1 Power Supply losses.

The D15 is specified to operate from 3.0V to 6.0V. In order to be able to work in the lowest battery values it is important to verify the losses in the power supplies lines, Flat cable and in the user PCB.

The D15 is a GSM phone that transmits in pulses of about 0.5mS any 4mS. The Peak current is about 1.5A.

The VCC line will drop down in the TX periods:

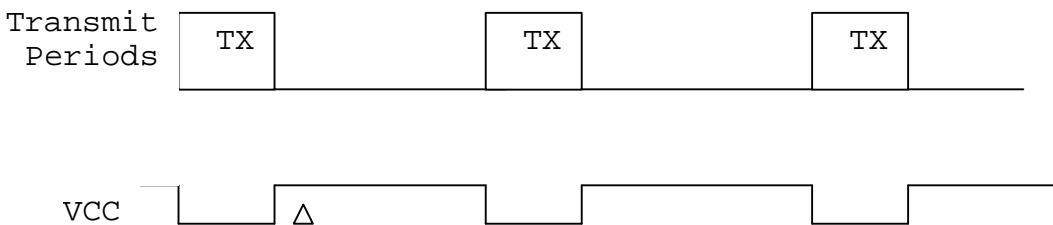

In order to minimize the Δ it is recommended to use a short Flat cable as possible and to put a 1000uF capacitor (or maximum possible) in the D15 VCC input.

5.1.2 Current consumption in D15:

In order to design the power supply correctly you need to take in account the current consumption of the D15 in the different

modes.

Mode	Current consumption
D15 with no accessory when no call is in process	<11mA Typical 10mA.
D15 with no accessory but TS or RTS are ON	< 50mA.
D15 during searching time	<180mA typical average 80mA.
D15 with DSC bus accessory (like Handset) when no call is in process	Typical 40 mA.
D15 during a call in maximum power level	<1.5A Peak, Average 300mA.
D15 during a call in GSM power level #10 (for Example)	<0.7A Peak, Average 175mA

5.1.3 How / When to make the unit to wakeup.

If the D15 will have no accessories and the unit is camped the D15 will go to a "sleep mode" (current save mode).

During this period of time the RS232 is not responding to any command from the DTE device. In order to make the unit to wake up when the DTE will like to communicate with the radio the user have two options:

1. Activate the RTS During all the DTE/DCE dialog. (Internaly the TS line will be activated). After the communication disable the RTS in order to go back to sleep mode.
2. Activate the TS During all the DTE/DCE dialog. After the communication disable the TS in order to go back to sleep mode.

Note: If the RTS or TS line will be active all the time the unit will not switch to Sleep mode and the avarage current consumption without a call will be arround 50mA.

Timing diagrams should be added. - TBD

5.2 Audio circuits consideration.

The D15 is able to make a voice call as well as Data calls. In voice calls the audio can be routed in a few channels:

Digital audio chanel - Audio is sent via the DSC bus.

Analog audio channel - Drived externaly to audio devices.

Analog audio channel in Hands free mode - D15 sens the audio out with the Echo canceling ON in the DSP, External drivers are required.

The Selection between each one of the channels can be done according to the table XX in paragraph 4.3.2.

5.2.1 Digital audio.

In case of digital audio channel a DCS drives is in used. The consideration that should be taken in this case is to be aware of the present of the hook switch. The hook switch will destinguish if the handset is In/Out of use.

There are two DSC bus accessories for audio defined for the D15:

External Handset.

DHFA - Car Kit for Hands Free.

5.2.2 Analog Audio without Handsfree.

The D15 will drive the audio out/in in order to allowed a voice call. In order to connect an Headset it is needed to amplified the speaker and microphone channels.

An example for these drivers can be seen in Apendix ?? EV board.

Other point to be taken in consideration is the Buzz noise existing in GSM phones due to the transmission rate (217Hz). In order to minimize this noise the D15 have a separate ground for the analog circuits.

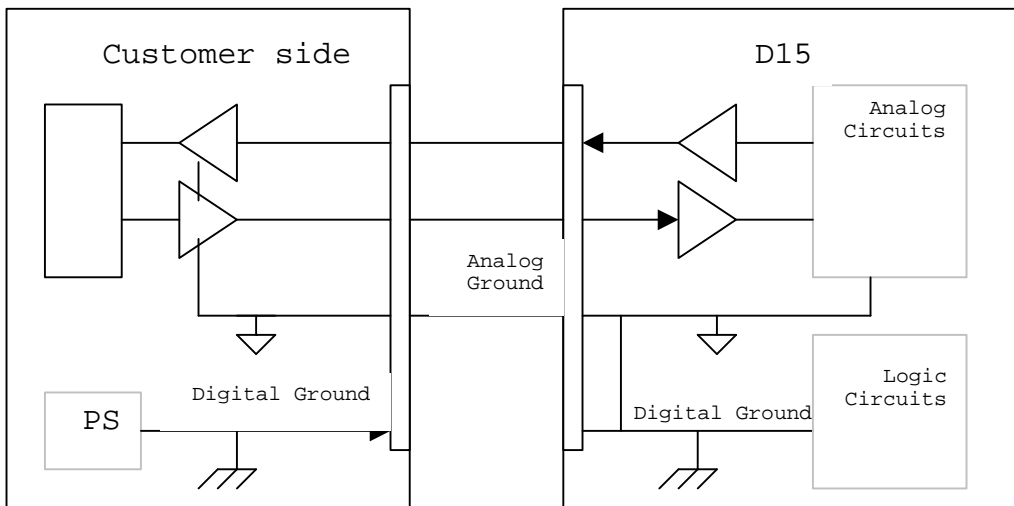

The main problem causing the Buzz is drops in the Ground line because the peak current during TX mode. In order to minimize the Buzz the following acts should be done:

- Use short Flat cable.
- Connect the analog ground from the D15 to all the analog circuits in the customer application without connecting them to the power supply ground.
- all the capacitors to ground in the audio circuits should be connected to the analog ground.
- Any reference voltage that may be used should have the external capacitor connected to the analog ground.

5.2.3 Analog Audio with Handsfree

The audio In/Out from the D15 for analog Handsfree are the same as for non Handsfree. All the consideration from Paragraph 5.2.2 are applicable for this mode too.

The additional consideration in this case is to switch the D15 DSP to Echo cancelling mode.

In order to switch to handsfree mode use the RS232 port by sending a switch command.

ATS96=1 Echo canceller is activate. (Handsfree)
ATS96=0 Echo canceller is disabled. (headset - Default)

5.3 Data port considerations.

5.3.1 Data levels.

The D15 data lines are operating in 0 to 5V logic. All the In/Out signals are buffered by an MC74VHCT244 buffer.

DTR, DSR, RTS, CTS, DCD lines are "1" (active) in 0V and "0" (inactive) in 5V.

The signal treshoulds are:

Vih 2.0V min.

Vil 0.8V max.

Voh 4.4V min. @ 50uA or 3.8V min. @ 8mA.

Vol 0.1 max. @ 50uA or 0.44V @ 8mA.

5.3.2 Select the data mode:

The D15 can support two different modes of operation:

SoftGsm - For PC applications.

RS232 full flow control - General applications.

The RS232 is the default mode and no action is needed to switch to this mode.

The SoftGsm require hardware connection to two lines.

Down link pin should be connected via 22KOhm to ground.

DSC_EN pin should be connected via 22KOhm to ground.

5.4 SIM lines consideration.

The SIM card can be used in 3 different ways: Internally in the D15, Externally by connecting a socket in the customer application and remotely via the DCS bus.

In case of externaly connection the customer concern should be for Full Type Approval that may require submission for testing in case that the SIM lines will be longer than 10cm.

This Paragraph should be completed.

5.5 ESD consideration - TBD

5.6 Antenna - To take from D10 manual.

5.7 Software - TBD

5.8 Mechanical - TBD

7. Appendix

7.1 Specifications

Physical

Form factor:	PCMCIA type III, no PCMCIA connector	
Size:	d15 DV Standard:	53.92x85.61x10.4mm
	(see drawings in this spec)	
	d15 DV Slim:	44.28x88.45x10.4mm
	d15 DVG with GPS:	44.74x88.45x17.6mm
	d15 DV DIN:	40x80.2x7.5 mm
Mounting:	Four 2.43mm Ø holes provided on non DIN models	
Weight:	D15 DV Standard:	39g
	D15 DV Slim:	35.5g

	D15 DVG with GPS:	49g
	D15 DV DIN:	22g
Volume:	D15 DV Standard:	cc
	D15 DV Slim:	cc
	D15 DVG with GPS:	cc
	D15 DV DIN:	cc
Housing material:	Plastic housing PC/ABS	
Interface connector:	d15 DV Standard / Slim/ DVG:	36 pin ZIF socket @ 0.5mm pitch ELCO #04-6240-036-800
	d15 DV Vertical Board Only:	28 pin dual in line Header @1.27 pitch (SAMTEC # FTSH-114 -01-L-DH)
	d15 DV Horizontal Board Only:	28 pin dual in line pin socket @1.27 pitch SAMTEC # CLP-114-02-L-D)
RF output connector:	MMCX Jack (female) 50Ω connectors Plug (Male)	GSM and GPS Mating
	Coax	Huber-Shuhner Johnson Components
	RG178	11-MMCX-50-1-1 135-3302-001
	RG316	11-MMCX-50-2-3 135-3403-001

Environmental
1

Operational temperature:	-30 to +60 degrees C
Storage temperature:	-40 to +85 degrees C
Shock:	20 g's with 11 millisecond duration, 20 impacts in three mutually perpendicular planes
Vibration:	IS-19: 1.5g acceleration, 5 to 500 Hz @ 0.1 octave/minute in three mutually perpendicular planes

Performance

Operating systems	GSM 900MHz, DCS 1800MHz, PCS 1900MHz.
Voltage:③	3.0 to 6V
Current:	10 mA Stand by 150uA off current 300mA avg. in call at power level 5 1.2 A peak @ 217 Hz at power level 5
Power out:	GSM - Power levels #19 to 5, 5dBm to 33dBm per ETSI. DCS - Power levels # 15 to 0, 0dBm to 30 dBm per

ETSI.
PCS - Power levels # 15 to 0, 0 dBm to 30 dBm per FCC.

SIM Card Reader:① Options: 1. Internal - chip SIM CR 3/5V SIM
2. External - Local interface 3/5 SIM
3. External - Remote interface (DSC interface) 5V only

Interface: Options 1. 9 pin RS232 Serial Asynchronous full flow control , 5V logic level
2. 4 pin RS232 Serial Asynchronous using SoftGsm SW for PC applications, 5V logic levels.
3. Motorola Proprietary DSC Bus
4. IRDA communication - In DIN models only.

Host Protocol: AT commands including GSM 07.07 and GSM 07.05 (see Developers manual for specific AT commands supported).

Data: Transparent/Non transparent up to 14.400 bps.
 - V.42 bis when using SoftGSM only.

PC FAX: Class 1,2 group 3 when using SoftGSM only

SMS: Send and receive (PDU and block mode per GSM 07.05)

Voice Call: Supported I/O with external H/SET

Audio: Analog - Full duplex I/O on interface connector

Digital - Motorola Proprietary DSC Bus

GPS: Independent GPS receiver on GPS model only

GPS (TXD, RXD, 1PPS, RTCM, Antenna Voltage) Functions are available on the ZIF and DIN header/socket connector at 3V logic levels.

1. 12 parallel channel

2. L1 1574,42 MHz

3. Code plus carrier tracking (carrier aided tracking)

4. Positional accuracy: 100 meters 2dRMS with SA as per DoD specifications, less than 25 meters SEP without SA

Additional specifications available on request