

**User / Operational Manual**

*Operational or User's Manual*

The manual should include instruction, installation, operator, or technical manuals with required 'information to the users'. This manual should include a statement that cautions the user that changes or modifications not expressly approved by the party responsible for compliance could void the user's authority to operate the equipment. The manual shall include RF Hazard warning statements, if applicable.

The instruction and service manual for this base radio are not published at this time. However, draft copy of available manual information has been assembled and has been included as part of this filing package.

Upon request, published manuals will be sent to the commission and/or telecommunication certification body (TCB) as soon as they become available. All of the descriptions, block diagrams, and schematics that are included in this filing package are current as of the package submittal date.

**EXHIBIT DESCRIPTION**

- D1-1 Manual Front Matter (Draft)
- D1-2 Specifications (Draft)
- D1-3 Field Replaceable Units and Orderable Parts (Draft)
- D1-4 Tune-Up Procedure (Draft)
- D1-5 Racking Configurations (Draft)
- D1-6 Functional Description / Operation of Modules (Draft)

## User / Operational Manual

Manual Front Matter (Draft)

i

## Foreword

This manual covers all versions of the MOTOTRBO MTR3000 Base Station/Repeater, unless otherwise specified. It includes all the information necessary to maintain peak product performance and maximum working time, using levels 1 and 2 maintenance procedures. This level of service goes down to the module replacement level and is typical of some local service centers, Motorola Authorized Dealers, self-maintained customers, and distributors.



**These servicing instructions are for use by qualified personnel only. To reduce the risk of electric shock, do not perform any servicing other than that contained in the Operating Instructions unless you are qualified to do so. Refer all servicing to qualified service personnel.**

### General Safety Precautions

See "General Safety and Installation Standards and Guidelines," on page ii.

### Computer Software Copyrights

The Motorola products described in this manual may include copyrighted Motorola computer programs stored in semiconductor memories or other media. Laws in the United States and other countries preserve for Motorola certain exclusive rights for copyrighted computer programs, including, but not limited to, the exclusive right to copy or reproduce in any form the copyrighted computer program. Accordingly, any copyrighted Motorola computer programs contained in the Motorola products described in this manual may not be copied, reproduced, modified, reverse-engineered, or distributed in any manner without the express written permission of Motorola. Furthermore, the purchase of Motorola products shall not be deemed to grant either directly or by implication, estoppel, or otherwise, any license under the copyrights, patents or patent applications of Motorola, except for the normal non-exclusive license to use that arises by operation of law in the sale of a product.

### Document Copyrights

No duplication or distribution of this document or any portion thereof shall take place without the express written permission of Motorola. No part of this manual may be reproduced, distributed, or transmitted in any form or by any means, electronic or mechanical, for any purpose without the express written permission of Motorola.

### Disclaimer

The information in this document is carefully examined, and is believed to be entirely reliable. However, no responsibility is assumed for inaccuracies. Furthermore, Motorola reserves the right to make changes to any products herein to improve readability, function, or design. Motorola does not assume any liability arising out of the applications or use of any product or circuit described herein; nor does it cover any license under its patent rights nor the rights of others. Controlled copies of this document is available via Motorola On-Line (MOL).

### Trademarks

MOTOROLA and the Stylized M logo are registered in the U.S. Patent & Trademark Office. All other product or service names are the property of their respective owners.

© 2010 by Motorola, Inc.  
All rights reserved.

## User / Operational Manual

*Manual Front Matter (Draft, Continued)*

## General Safety and Installation Standards and Guidelines

**ATTENTION!**

**WARNING:** For safe installation, operation, service and repair of this equipment, follow the safety precautions and instructions described below, as well as any additional safety information in Motorola's product service and installation manuals and the Motorola R56 Standards and Guidelines for Communications Sites manual (6881089E50). To obtain copies of these materials, please contact Motorola as directed at the end of this section. After installation, these instructions should be retained and readily available for any person operating or servicing this base station/ repeater or working near it.

Failure to follow these safety precautions and instructions could result in serious injury or property damage.

The installation process requires preparation and knowledge of the site before installation begins. Review installation procedures and precautions in the Motorola R56 manual before performing any site or component installation. Personnel must use safe work practices and good judgment, and always follow applicable safety procedures, such as requirements of the Occupational Safety and Health Administration (OSHA), the National Electrical Code (NEC), and local codes.

The following are additional general safety precautions that must be observed:

- To continue compliance with any applicable regulations and maintain the safety of this equipment, do not install substitute parts or perform any unauthorized modifications.
- All equipment must be serviced by Motorola trained personnel.
- If troubleshooting the equipment while the power is on, be aware of live circuits which could contain hazardous voltage.
- Do not operate the radio transmitters unless all RF connectors are secure and all connectors are properly terminated.
- All equipment must be properly grounded in accordance with the Motorola R56 and specified installation instructions for safe operation.
- Slots and openings in the cabinet are provided for ventilation. Do not block or cover openings that protect the devices from overheating.
- Some equipment components can become extremely hot during operation. Turn off all power to the equipment and wait until sufficiently cool before touching.
- Maintain emergency first aid kits at the site.
- Never store combustible materials in or near equipment racks. The combination of combustible material, heat and electrical energy increases the risk of a fire hazard.
- Equipment shall be installed in a site that meets the requirements of a "restricted access location," per (UL60950-1 & EN60950-1), which is defined as follows: "Access can only be gained by service persons or by users who have

## User / Operational Manual

*Manual Front Matter (Draft, Continued)*

been instructed about the reasons for the restrictions applied to the location and about any precautions that shall be taken; and access is through the use of a tool or lock and key, or other means of security, and is controlled by the authority responsible for the location."

- Burn hazard. The metal housing of the product may become extremely hot. Use caution when working around the equipment.
- RF energy burn hazard. Disconnect power in the cabinet to prevent injury before disconnecting and connecting antennas.
- Shock hazard. The outer shields of all Tx and Rx RF cables outer shields must be grounded per Motorola R56 manual.
- Shock hazard. DC input voltage shall be no higher than 60 VDC. This maximum voltage shall include consideration of the battery charging "float voltage" associated with the intended supply system, regardless of the marked power rating of the equipment.
- All Tx and Rx RF cables shall be connected to a surge protection device according to Motorola R56 manual. Do not connect Tx and Rx RF cables directly to an outside antenna.
-  Compliance with National and International standards and guidelines for human exposure to Electromagnetic Energy (EME) at Transmitter Antenna sites generally requires that persons having access to a site shall be aware of the potential for exposure to EME and can exercise control of exposure by appropriate means, such as adhering to warning sign instructions. See this installation manual and Appendix A of Motorola R56.

This product complies with the requirements set forth by the European R&TTE regulations and applicable CENELEC standards concerning human exposure to Electromagnetic Energy (EME) at Transmitter Antenna sites. "Appendix G" in this manual includes an EME exposure analysis of a typical system configuration for this product.

For a different system configuration than the typical configuration, compliance with applicable EME exposure standards (current versions of the EN50384 and EN50385 standards for occupational and general public exposure, respectively) can be evaluated by either employing the method illustrated in the typical system configuration EME exposure analysis included in "Appendix G" in this manual, or employing another suitable method among those described in the current version of the EN50383 standard.

Once the occupational and general public compliance boundaries are determined, means to ensure that workers and people are outside the respective boundaries, for instance using appropriate signage or restricted access, should be implemented; if this is not possible or practically achievable for the specific system configuration, the configuration should be modified in order to make it possible. The R56 Standards and Guidelines for Communications Sites (6881089E50) manual provides examples of signage that can be used to identify the occupational or general public compliance boundaries.

Refer to product specific manuals for detailed safety and installation instructions. Manuals can be obtained with product orders, downloaded from <https://businessonline.motorola.com>, or purchased through the Motorola Aftermarket & Accessory Department.



WARNING

**This is a class A product. In a domestic environment, this product may cause radio interference in which case the user may be required to take adequate measures.**

---

## Environmental Information

### Material Content

**Note** The Motorola MOTOTRBO MTR3000 Base Station/Repeater system and its subsystems have been created in compliance with the environmental goals of the European Union's **Restriction of Hazardous Substances (RoHS)** and the **Waste Electrical and Electronic Equipment (WEEE)** Directive 2002/96/EC as well as Motorola's corporate goals to minimize environmental impact of its products.

This Motorola policy is reflected throughout the entire design, procurement, assembly, and packaging process.

In support of these efforts to provide environmentally-responsible products, please comply with the information in the following sections regarding product disposal for systems being replaced.

### Disposal of your Electronic and Electric Equipment

Please do not dispose of electronic and electric equipment or electronic and electric accessories with your household waste. In some countries or regions, collection systems have been set up to handle waste of electrical and electronic equipment.

In European Union countries, please contact your local equipment supplier representative or service center for information about the waste collection system in your country.

### Disposal Guideline

The following symbol on a Motorola product indicates that the product should not be disposed of with household waste.



User / Operational Manual

Specifications (Draft)

|   |                                       |  |                     |
|---|---------------------------------------|--|---------------------|
| <b>General Performance</b>              |                                       |  |                     |
| Model                                   | T3000                                 |  |                     |
| Number of Channels                      | 16                                    |  |                     |
| Frequency Generation                    | Synthesized                           |  |                     |
| H x W x D                               | 5.25" x 19" x 16.5" (133x483x419mm)   |  |                     |
| Weight                                  | 40 lbs (19 kg)                        |  |                     |
| Power Requirements                      |                                       |  |                     |
|   | AC: 85-264 VAC, 47-63 Hz              | Standby 0.4A, Rated Power 3.3A @ 117 VAC |                     |
|   | DC: 21.6 - 32 Volts DC                | Standby 1.0A, Rated Power 11.5A @ 28 VDC |                     |
| Temperature Range                       | -30 to 60 °C (-22 to 140 °F)          |  |                     |
| Input / Output Impedance                | 50 ohms                               |  |                     |
| Antenna Connectors Tx / Rx              | N-Type                                |  |                     |
| Modes of Operation                      | Half-Duplex / Duplex                  |  |                     |
| Frequency Band                          | 136 - 174 MHz                         |  |                     |
| Internal Frequency Stability            | 1.5 PPM                               |  |                     |
| External Reference Capable              | Yes                                   |  |                     |
| Channel Spacing                         | 12.5 kHz, 25 kHz                      |  |                     |
| <b>Transmitter</b>                      |                                       |  |                     |
| Frequency Range                         | 136-174 MHz                           |  |                     |
| Rated Output Power                      | 8 - 100 Watts, Variable               |  |                     |
| Intermodulation Attenuation             | 55 dB                                 |  |                     |
| Adjacent Channel Power                  | -75 dBc (25 kHz) / -60 dBc (12.5 kHz) |  |                     |
| Wideband Noise (1 MHz)                  | -152 dBc/Hz                           |  |                     |
| Rated System Deviation                  | 5 kHz (25 kHz) / 2.5 kHz (12.5 kHz)   |  |                     |
| Audio Distortion                        | <3%                                   |  |                     |
| FM Hum and Noise                        | 50 dB (25 kHz) / 45 dB (12.5 kHz)     |  |                     |
| Spurious Harmonic Emissions Attenuation | -90 dBc                               |  |                     |
| <b>FCC Type Acceptance</b>              |                                       |  |                     |
|   | <b>FCC Identifier:</b>                | <b>Frequency Range</b>                   | <b>Type</b>         |
|   | ABZ89FC3793                           | 136-174 MHz                              | Transmitter         |
|   | ABZ89FR3794                           | 136-174 MHz                              | Receiver            |
|   |                                       |  | <b>Power Output</b> |
|   |                                       |  | Variable 8-100 W    |
|   |                                       |  | N/A                 |
|   |                                       |  |                     |
|   |                                       |  |                     |

User / Operational Manual

Field Replaceable Units and Orderable Parts (Draft)

Motorola provides the following approved accessories to improve the productivity of your base station / repeater. For a list of Motorola-approved accessories, visit the following web site:

<http://www.motorola.com/governmentandenterprise>.

**MOTOTRBO MTR3000 Ordering Guideline**

| Model     | Description  |
|-----------|--|
| T3000     | MTR3000 Base Station/Repeater  |
| X330MT    | VHF 100W Power (136–174 MHz)   |
| X340MT    | UHF 100W Power (403–470 MHz)   |
| X540MT    | UHF 100W Power (470–524 MHz)   |
| X450MT    | 800 MHz 100W Power (806–870 MHz)   |
| X460MT    | 900 MHz 100W Power (896–941 MHz)   |
| X182VL    | Duplexer, UHF 136–146 MHz  |
| X182VM    | Duplexer, UHF 144–160 MHz  |
| X182VN    | Duplexer, UHF 158–174 MHz  |
| X182UL    | Duplexer, UHF 403–435 MHz  |
| X182UM    | Duplexer, UHF 435–470 MHz  |
| X182UN    | Duplexer, UHF 470–494 MHz  |
| X182UH    | Duplexer, UHF 494–512 MHz  |
| X182EB    | Duplexer, 800 MHz  |
| X265VL    | Preselector, VHF 136–154 MHz   |
| X265VM    | Preselector, VHF 150–174 MHz   |
| X265UL    | Preselector, UHF 380–435 MHz   |
| X265UM    | Preselector, UHF 435–470 MHz   |
| X265UH    | Preselector, UHF 470–524 MHz   |
| X676VL    | Circulator, VHF (136–146 MHz)  |
| X676VM    | Circulator, VHF (144–160 MHz)  |
| X676VH    | Circulator, VHF (158–174 MHz)  |
| X676UL    | Dual Circulator, UHF (403–470 MHz)   |
| X676UH    | Dual Circulator, UHF (470–524 MHz)   |
| X676EB    | Circulator, 800 MHz  |
| X216AR    | 4-Wire Wireline  |
| X371BA    | Antenna Relay (Note: Antenna Relay is not compatible if ordering X182, Duplexer) |
| X189AA    | Power Cable, Europe  |
| X162AD    | Power Cable, UK  |
| X191AD    | Power Cable, Australia   |
| CA01520AA | Power Cable, DC  |
| U178AB    | Cabinet Mount Hardware   |
| X153BA    | Rack Mount Hardware  |
| X244AF    | Auxiliary System Cable   |
| X244AG    | Community Base Station/Repeater Panel Cable                                      |
| X244AH    | Phone Patch Cable  |
| C540AD    | System Connector Cable   |
| HKLN4439_ | MTR3000 Capacity Plus Software Upgrade   |
| X347AF    | Manual Install and User CD   |

Customer Replaceable Power Cables for Standalone Base Radio

| Part Number | Description                     |
|-------------|---------------------------------|
| TRN7663A    | Power Cable, North America      |
| TRN7755A    | Power Cable, Continental Europe |
| TTN5049A    | Power Cable, UK / Ireland       |
| TTN5103A    | Power Cable, Australia          |

User / Operational Manual

Field Replaceable Units and Orderable Parts (Draft) (Continued)

**MOTOTRBO MTR3000 Field Replaceable Units**

| <b>Model</b> | <b>Description</b>                        | <b>Model</b> | <b>Description</b>        |
|--------------|---|--------------|---------------------------|
| DLN6710_     | 100W PA, VHF 136-174 MHz                  | DLN6701_     | 100W PA, UHF 403–470 MHz  |
| DLN6712_     | Exciter, VHF 136-174 MHz                  | DLN6702_     | 100W PA, UHF 470–524 MHz  |
| DLN6713_     | Receiver, VHF 136-174 MHz                 | DLN6703_     | Exciter, UHF 403–470 MHz  |
| DLN6714_     | 100W PA, 800/900 MHz                      | DLN6704_     | Exciter, UHF 450–524 MHz  |
| DLN6715_     | Exciter, 800/900 MHz                      | DLN6705_     | Receiver, UHF 403–470 MHz |
| DLN6716_     | Receiver, 800/900 MHz                     | DLN6706_     | Receiver, UHF 450–524 MHz |
| DLN6707_     | AC/DC Power Supply                        |              |                           |
| DLN6719_     | Station Control TCXO                      | DLN6718_     | Station Control OCXO      |
| CLN8629_     | MOTOTRBO MTR3000 Installation and User CD |              |                           |
| X347AF       | Manual Install and User CD                |              |                           |

**Note** The Manual Install and User CD contains:

- MOTOTRBO MTR3000 Installation and User Manual (Including MTR2000 to MTR3000 MOTOTRBO Upgrade Kit)
- MOTOTRBO MTR3000 Basic Service Manual

**Microphones/Speakers**

| <b>Model</b> | <b>Description</b>         |
|--------------|----------------------------|
| GMMN4063     | Noise Cancelling Mic       |
| 0185180U01   | Cable For External Speaker |
| HSN1006      | Speaker                    |

**Miscellaneous Accessories**

| <b>Model</b> | <b>Description</b>   |
|--------------|--|
| RRX4025      | ISB50LNC2 Bulkhead Arrestor 125-100                            |
| RRX4032      | T-1 ISB50 Series Round Member Mount                            |
| RRX4021      | Lightening / Surge Arrestor                                    |
| RRX4034      | Lightening / Surge Arrestor (110/220V AC Line Surge Protector) |
| TRN4589      | Dual Line Suppressor   |
| 3083908X02   | Cable, Field System Adapter                                    |

|           |                               |
|-----------|-------------------------------|
| CLN1317*  | Antenna Relay                 |
| CLN1316** | Antenna Relay For Preselector |

Note

(\*) Includes Antenna Relay and required cables for stations without X265, Preselector

(\*\*) Includes Antenna Relay and required cables for stations that include X265, Preselector

|           |                                     |
|-----------|-------------------------------------|
| CKN1039*  | Preselector Cable Kit               |
| CKN1040** | Preselector Cable For Antenna Relay |

Note

(\*) Order this cable for stations without X371, Antenna Relay

(\*\*) Order this cable for stations with X371, Antenna Relay

**Cabinets/Racks and Hardware**

| <b>Model</b> | <b>Description</b>          | <b>Model</b> | <b>Description</b>             |
|--------------|-----------------------------|--------------|--------------------------------|
| THN6700      | 12 inch Indoor Cabinet      | THN6752      | 30 inch Modular Rack (16 RK U) |
| THN6701      | 30 inch Indoor Cabinet      | THN6753      | 45 inch Modular Rack (24 RK U) |
| THN6702      | 46 inch Indoor Cabinet      | THN6754      | 52 inch Modular Rack (27 RK U) |
| THN6788_     | Slides Motorola Cabinet     |              |                                |
| CLN6833_     | Slides Non-Motorola Cabinet |              |                                |
| CLN6679_     | Rack Mount Hardware         |              |                                |



**User / Operational Manual***Tune-Up Procedure (Draft)*

All adjustments are software controlled and are pre-set at the factory. Certain station operating parameters can be changed using Customer Programming Software (CPS), within predetermined limits. Examples include transmit / receiver operating frequencies and transmitter power level.

After the base station / repeater and ancillary equipment have been mechanically installed, properly cabled, and power applied, the equipment must then be optimized; that is, before placing the base station / repeater in operation. The cable required is a standard "USB A to B" cable. Optimization is performed through the Customer Programming Software (CPS), kit number RVN5115.

After the base station / repeater is operational, the base station / repeater's codeplug data must be copied to a PC- compatible computer.

Optimization involves the following tasks:

1. Reading the base station / repeater codeplug from the base station / repeater (this ensures a match between the base station / repeater serial number (resident in the codeplug) and the serial number (part of the customized base station / repeater codeplug data) that is written back to the base station / repeater (see task 5).
2. Customizing the base station / repeater codeplug and saving the data to the base station / repeater.
3. Aligning the base station / repeater for:
  - Modulation Limit
  - Speaker Level
  - Station Reference
  - MTR2000 PA Calibration
  - Receiver Squelch Adjust
4. Performing post-optimization procedures.
5. Writing the customized codeplug to the base station / repeater codeplug.

For details on these tasks, refer to the Customer Programming Software (CPS) Online Help.

User / Operational Manual

*Racking Configurations (Draft)*

There are various equipment racking configurations available to customers. The following section depicts some of the racking alternatives.

**Floor-Mount Cabinet**

The front, side and top views for all available floor-mount cabinets are shown below. Cabinet models and hardware are shown in the following table:

| Model   | Description                 |
|---------|-----------------------------|
| THN6700 | 12 inch Indoor Cabinet      |
| THN6701 | 30 inch Indoor Cabinet      |
| THN6702 | 46 inch Indoor Cabinet      |
| THN6788 | Motorola Cabinet Slides     |
| CLN6833 | Non-Motorola Cabinet Slides |

See the installation manual for recommended equipment ventilation clearances. For improved access to the unit, tray slides are available as shown in the table above.

|   |   |
|---|---|
| <br><b>WARNING</b> | <p>Ensure that the cabinet is securely anchored to the floor, thereby avoiding possible equipment tipping and personal injury. Refer to Mounting Floor-Mount Cabinets for details on proper cabinet installation.</p> |
|---|---|

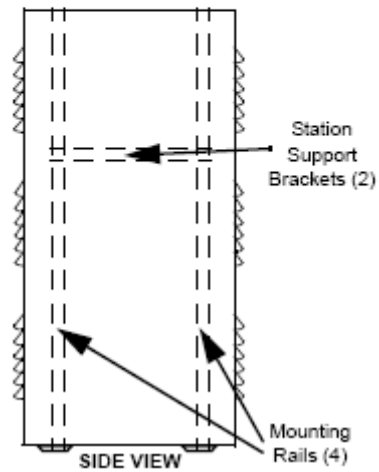
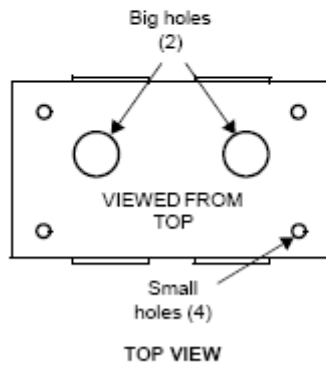
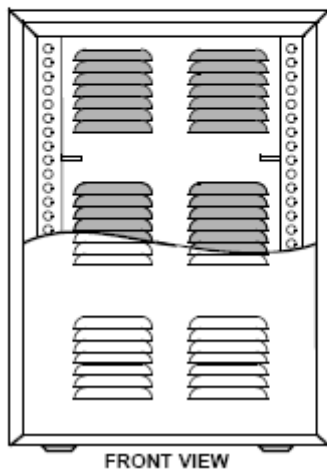

User / Operational Manual

Racking Configurations (Draft, Continued)

**Modular Racks**

The front, side and top views for all available floor-mount cabinets are shown below. The cabinet models and associated description are shown in the following table:

| Rack Model | Description                    |
|------------|--------------------------------|
| THN6752    | 30 inch Modular Rack (16 RK U) |
| THN6753    | 45 inch Modular Rack (24 RK U) |
| THN6754    | 52 inch Modular Rack (27 RK U) |

The side, top and bottom views for all available modular racks are shown below. The top and bottom plates are identical, and all dimensions and clearances are common to all racks.

Recommended clearance front and rear is 91.44 cm (36 in) minimum for servicing access. Refer to Equipment Ventilation for recommended ventilation clearances.

FRU kit CLN6679 (Rack Mount Hardware) is included with each rack model. This allows proper installation of the MTR3000 base station / repeater within the rack's center of gravity.

**NOTE:** This kit includes two rack mount standoffs and eight mounting screws.

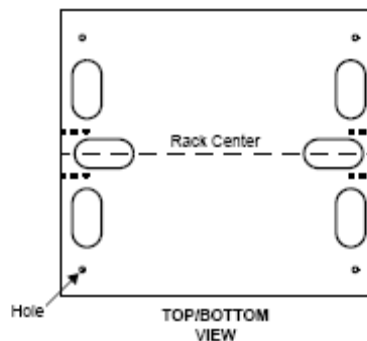
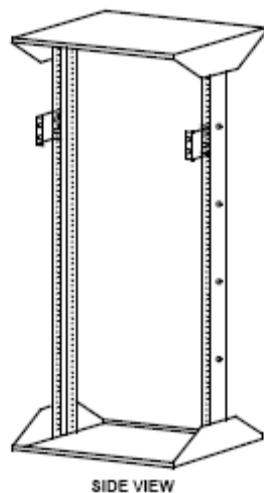

User / Operational Manual

*Functional Description / Operation of Modules (Draft)*

*Base Radio Module Overview*

The Motorola MTR3000 Base Station / Repeater (BR) provides a modular, flexible analog and digital station design for today's communication systems and of the future. The stations are available for use in Analog Conventional, Digital Conventional (MOTOTRBO), LTR Trunking, Passport Trunking, MOTOTRBO Capacity Plus Trunking, and MOTOTRBO Connect Plus Trunking configurations.

The MTR3000 BR can either be configured as a stand-alone base station / repeater or as a base station / repeater connected to a back-end network, as in the case of operating in IP Site Connect mode. As a base station / repeater, it listens on one uplink frequency, and then re-transmits on a downlink frequency thus providing the RF interface to the field subscribers. When configured for analog station operation, the BR is designed to operate with most existing analog systems, therefore making a smooth migration to the MOTOTRBO system.

When configured for digital operation, the BR offers additional services. The digital BR operates in TDMA mode, which essentially divides one channel into two virtual channels using time slots; therefore the user capacity is doubled. The BR utilizes embedded signaling to inform the field radios of the busy/idle status of each channel (time slot), the type of traffic, and even the source and destination information.

Note: When configured in Digital Mode, the BR can only be used as a repeater.

Note: At any given time, the BR either operates as a digital repeater or as an analog repeater.

The MTR3000 BR is divided into functional modules that separate the frequency band specific and transmitter power specific circuits from other circuits and has separate modules for the control interface. These modules are self contained functional blocks with module-specific alarms. This design facilitates the field replaceable unit (FRU) concept of field repair to maximize system uptime.

*Indicators and Connections*

This section describes the LED indicators and connectors provided on the base station / repeater. The set of LEDs indicate the operational status of the base station / repeater. There are two sets of connectors for devices external to the base station / repeater:

- One set connects to external devices to enable full operation of the base station / repeater. These are located at the back of the base station / repeater.
- Another set connects to external devices for servicing the base station / repeater. These are located on the Station Control Module.

LED Indicators

A set of eight LEDs is located on the base station / repeater front bezel. The position of the eight LEDs on the front bezel is shown below. These LEDs indicate the status of the base station / repeater during normal operation.



*Front Bezel LEDs and Connectors*

After booting up the base station / repeater, the six LEDs (Power/Status, TX Slot 1, TX Slot 2, RX Slot 1, RX Slot 2 and the Mode LEDs) flashes in unison. The general status and condition of the MTR3000 Base Station / Repeater can be obtained by observing the eight LED indicators on the front bezel. The following tables show the LED symbols and their meaning and identify the information conveyed via the LED indicators.

User / Operational Manual

Functional Description / Operation of Modules (Draft)

| LED | Definition   | LED Function Name      | LED Color       | LED State | Status Indication   |
|-----|--|------------------------|-----------------|-----------|---|
|     | Status   | Boot-up                | Green (All LED) | Flashing  | Station booting up  |
|     | TX Slot 1 (for label number 1)<br>TX Slot 2 (for label number 2) | Power/Status           | Off             | Off       | Station Off   |
|     |  |                        | Green           | Flashing  | Station Operating Normally, with DC power   |
|     |  |                        |                 | Solid     | Station Operating Normally, with AC power   |
|     |  |                        | Red             | Flashing  | Station Operational – Minor Alarm   |
|     |  |                        |                 | Solid     | Station Not Operational – Major Alarm   |
|     | RX Slot 1 (for label number 1)<br>RX Slot 2 (for label number 2) | TX Slot 1<br>TX Slot 2 | Off             | Off       | Transmitter is not transmitting   |
|     |  |                        | Green           | Solid     | Transmitter is transmitting   |
|     |  |                        |                 | Flashing  | Transmitter is transmitting, but at reduced power out   |
|     | Mode   | RX Slot 1<br>RX Slot 2 | Off             | Off       | Receiver qualifier has not been met   |
|     |  |                        | Green           | Solid     | Receiver qualifier has been met   |
|     | Ethernet Link  | Mode                   | Off             | Off       | Analog Mode (FM)  |
|     |  |                        | Blue            | Solid     | Digital Mode (2 Slot TDMA, 4FSK)  |
|     | Reference  | Ethernet Link          | Off             | Off       | No Ethernet connection  |
|     |  |                        | Green           | Solid     | Linked  |
|     |  |                        |                 | Flashing  | Network traffic   |
|     | Reference  | Reference              | Off             | Off       | No external reference is present  |
|     |  |                        | Green           | Solid     | Training process is completed and the calibration data has been written to the EEPROM or external reference is present after training which the BR has phase locked to. |
|     |  |                        | Amber           | Solid     | Lock to external reference and training is in progress  |

Front Bezel LED Indicators

External Connections - Electrical Connections for the base station / repeater external connectors and line cord are located on the back panel and are shown below.

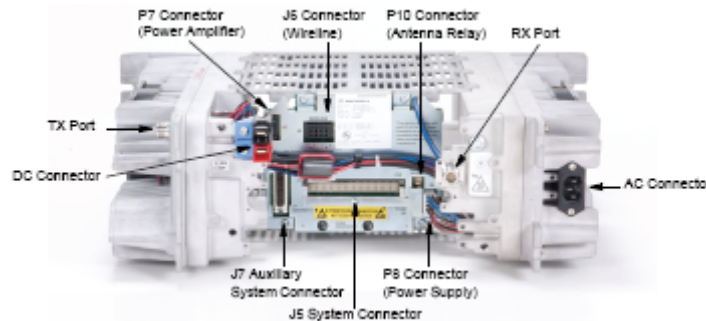

Location of External Connectors at Rear of Base Station / Repeater

The connection to external devices on the back panel is the J7 Auxiliary System Connector. The connector is a 25-pin connector used for connecting to an external device such as a trunking controller, tone remote adaptor, or phone patch.

Service ports and LEDs are located on the front of the Station Control Module (SCM). The connection to external devices on the front of the station control module is the BNC connector. The connector allows the base station / repeater to be connected to a 5 MHz or 10 MHz external reference signal. The service ports include connectors for:

- 5/10 MHz External Reference Signal
- Ethernet Connector
- Service Speaker Connector
- USB Connector
- Service Microphone Connector

User / Operational Manual

Functional Description / Operation of Modules (Draft)

The locations of the connectors on the front of the station control module are shown below.

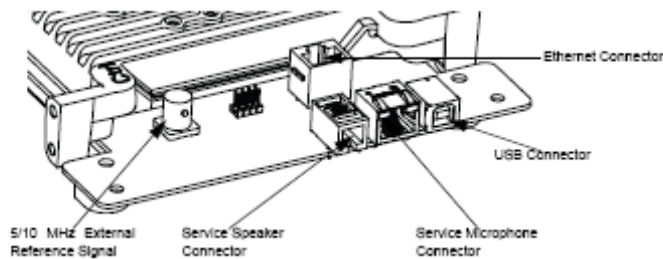

Control Overview

The Station Control Module (SCM) is described in this section. A general description, identification of controls, indicators, and inputs/outputs, a functional block diagram, and functional theory of operation are provided. The information provided is sufficient to give service personnel a functional understanding of the module, allowing maintenance and troubleshooting to the module level.

General Description

The SCM circuitry performs the digital signal processing, data formatting and audio routing for the base station / repeater (BR) and provides the external interfaces to the rest of the site.

The SCM uses two TI OMAP1710 processors:

- One for transmit and overall BR control functionalities
- One for all receive functionalities

Both OMAP1710 processors have independent boot Flash and RAM and, therefore can boot independently.

General SCM functionality includes:

- Data and Control interface to the Receiver's Abacus III devices
- Data and Control interface to the Exciter's Trident chip set
- Audio Codec interface with MAKO IC
- Host memory size, speed, and types supported
- External ports (Ethernet, USB, speaker and microphone)
- External physical interfaces (switches, connectors, LEDs, external references etc.)
- TX/RX DSP Multi-Channel Buffered Serial Port (MCBSP) interfaces
- Intermodule communication (using SPI)
- Internal station reference generation

Functional Theory of Operation

The following theory of operation describes the operation of the SCM at a functional level. The information is presented to give the service technician a basic understanding of the functions performed by the module in order to facilitate maintenance and troubleshooting to the module level.

**TX OMAP** - The TX DSP is a TI OMAP Multimedia Processor. The OMAP1710 consists of a microprocessor unit (MPU) subsystem and a digital signal processor (DSP) subsystem.

OMAP1710 has dedicated external memory interface that allow point-to-point connection to standard mobile SDRAM/DDR and mobile flash devices. It is a low-power device (1.4V Core and 1.8V I/O supply). TX OMAP handles all transmit tasks of the SCM.

**External Memory** - Both transmit and receive DSP's support independent external memory banks.

**RAM** - The SCM supports Mobile Double Data Rate SDRAM. It has the following basic characteristics: The maximum external clock rate for the DDR is 90 MHz. Since data is transferred on both clock edges, the effective data rate is 180 Mwords/s.

**Flash** - The SCM supports 256 MB external flash memory.

**Serial Peripheral Interface (SPI)** - The station local and Intermodule SPI Bus is controlled by both TX and RX OMAP1710 processors, which has an on-chip SPIF (fast SPI) interface. The OMAP1710 SPIF supports master

*Functional Description / Operation of Modules (Draft)*

and slave modes, programmable clock rate, phase, polarity, programmable word size, programmable bit ordering, and loopback.

Before an SPI data transfer can take place, the SPI master (initiator) must assert the select line of the slave (target) device. The OMAP1710 is always the SPI master for MTR3000 BR. To simplify overall SPI architecture for MTR3000 BR, address decoding is used instead of individual device chip signals. This approach not only minimizes the number of GPIOs needed for device chip select, it also provides flexibility for future expansion. This device address decoding is handled by a Field Programmable Gate Array (FPGA) on the SCM and a Customer Programmable Logic Device (CPLD) on each FRU's, except the power supply.

The FPGA SPI module performs address and chip select decoding, level shifting, and signal mixing for both the TX OMAP SPI bus and the RX OMAP SPI bus. Simultaneous RX and TX SPI accesses are allowed. The TX and RX SPI are 100% independent.

Station Reference RX - A TCXO provides the frequency reference for the BR. The TCXO is 16.8 MHz. The FPGA is used to create other clocks locked to the TCXO which are needed by various devices on the Control Board.

The clocks are summarized in the following table:

*Station Control Module (SCM) FPGA output Frequencies*

| <u>Frequency</u> | <u>Destination</u>     |
|------------------|------------------------|
| 12 MHz           | TX OMAP, RX OMAP       |
| 24.576 MHz       | MAKO                   |
| 32.768 kHz       | TX OMAP, RX OMAP, MAKO |

**RX OMAP**

The RX DSP is a TI OMAP Multimedia Processor. The OMAP1710 consists of a microprocessor unit (MPU) subsystem and a digital signal processor (DSP) subsystem. OMAP1710 has dedicated external memory interface that allows point-to-point connection to standard mobile SDRAM/DDR and mobile flash devices. It is a low-power device (1.4V Core and 1.8V I/O supply). The RX OMAP handles receiving tasks of the SCM only.

MAKO - MAKO IC is a customized IC and the SCM uses this device to leverage some unique functionality that it provides.

Most of the MAKO functionalities are not used on the SCM. Only the MAKO codec, USB driver, ADC, DAC, and some voltage regulators are used for MTR3000. The 9 channel general purpose ADC is used for various controller metering.

Field Programmable Gate Array (FPGA) - The SCM FPGA includes the following major functions:

- External reference watchdog
- SPI Address decoding and buffering
- TCXO Phase detection and compensation
- Clock generation
- Reset controller
- External Interface (Wireline SSI, LED, etc.)

FPGA field upgrade capability is also supported on MTR3000.

Audio - There are four transmit inputs: TX Audio, TX Audio-Pre & TX Data on the backplane 25-Pin connector, and the microphone input on a front panel RJ45 connector.

TX Audio is a flat (not pre-emphasized) input which is used if the incoming transmit audio signal is already pre-emphasized or if pre-emphasis is not needed. The TX Audio-Pre input provides a hardware pre-emphasis filter. The TX Data input is used for low speed data, Private-Line (PL) and Digital Private Line (DPL) signals. The TX Audio, TX Audio-Pre and microphone inputs pass through a hardware modulation limiter and splatter filter before being summed with TX Data, with the TX Data bypassing the limiter and splatter filter. This summed signal is applied to the MAKO codec "mic" input. The audio signal without TX Data is provided on the MAKO codec "aux\_mic" input.

There are three receive outputs: RX Audio & Aux RX Audio on the backplane 25-Pin connector and speaker audio on a front panel RJ11. The speaker audio is the sum of the MAKO codec output (demodulated audio) and transmit audio. A high pass filter removes any data, PL or DPL from the speaker audio. A programmable attenuator is used to adjust the speaker audio level before being output on the RJ11 connector. Aux RX Audio is the output of

User / Operational Manual

Functional Description / Operation of Modules (Draft)

the MAKO codec (demodulated audio), and RX Audio is the sum of the MAKO codec output and the microphone audio.

A block diagram of the audio paths follows:

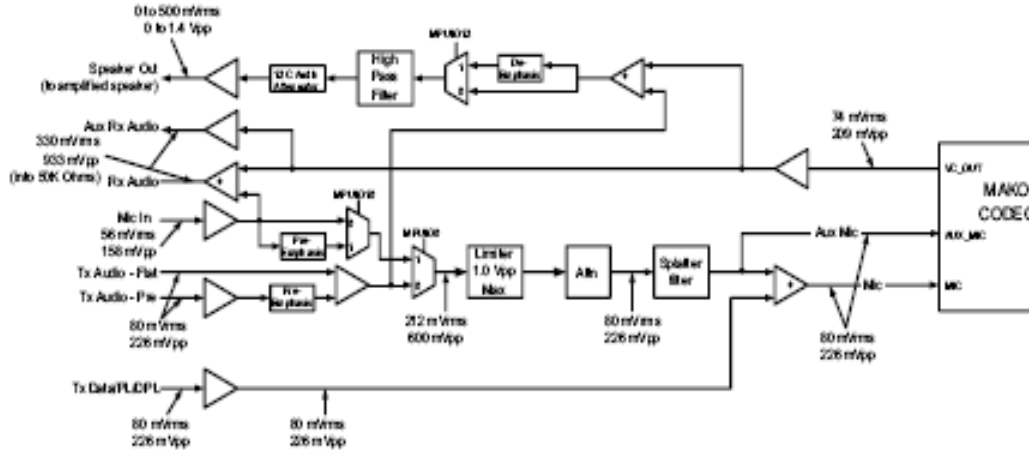

Ethernet Interface - Since OMAP1710 does not support a direct Ethernet interface, a bridge device is needed to support Ethernet on the SCM. The bridge device is a high performance hi-speed USB2.0 to 10/100 Ethernet controller. The device contains an integrated 10/100 Ethernet PHY, USB PHY, Hi-Speed USB 2.0 device controller, 10/100 Ethernet MAC, TAP controller, EEPROM controller and a FIFO controller with a total of 30 KBytes of internal packet buffering. The following is a list for functionality that the Ethernet Interface can provide:

- Fully Compliant with IEEE 802.3 and 802.3u Compatible Ethernet Controller
- 10Base-T and 100Base-TX support
- Integrated Media Access Control (MAC) and PHYSical (PHY)
- Supports one 10BT port with automatic polarity detection and correction
- Supports full and half duplex mode and flow control
- Universal Serial Bus (USB) and Joint Test Action Group (JTAG) parameters

Backplane - The connector that connects the controller to the backplane is a right angle, 96-Pin Connector. It provides connectivity between the MTR3000 controller and other station FRU, such as the Wireline card, the AUX IO card as well as, third party equipments.

Exciter - The connector used to connect the controller to the Exciter and Receiver is a dual row, right angle, early entry receptacle, without flange, 30-Pin Connector. It provides 16.8 MHz reference clock, 14.2V, 10V and 8V supply voltage, SPI, Trident SSI and other digital handshake signals with the Exciter.

Receiver - The connector used to connect the controller to the Exciter and Receiver is a dual row, right angle, early entry receptacle, without flange, 30-Pin Connector. It provides 16.8 MHz reference clock, 14.2V, 10V and 8V supply voltage, SPI, Abacus SPI/SSI and other digital handshake signals with the Receiver.



*Functional Description / Operation of Modules (Draft)*

*Receiver Overview*

The Receiver Module consists of a Receiver RF board in a clamshell housing assembly. It provides the Receiver functionality for the MTR3000 Base Station/Repeater and performs highly-selective bandpass filtering and dual down-conversion of the desired RF signal. A custom Receiver IC then performs an analog-to-digital conversion of the desired received signal and outputs a differential data signal to the Station Control Module (SCM).

Overview of Circuitry

The Receiver Module contains the following circuitry:

- Frequency Synthesizer Circuitry – consists a phase-locked loop and Voltage-Controlled Oscillator (VCO), generates the first LO injection signal
- Varactor-tuned Preselector Filter – provides bandpass filtering of the station Receiver RF input
- Receiver Front End Circuitry – performs filtering, amplification, and the first down conversion of the Receiver RF signal
- Custom Receiver IC Circuitry – consists a custom IC which performs the second down conversion, filtering, amplification, and analog-to-digital conversion of the receive signal
- Analog to Digital Converter (ADC) Converter Circuitry – converts analog Receiver status signals to digital format for transfer, upon request, to the SCM
- Local Power Supply Regulation – accepts +8V, +10V and +14.2V inputs and outputs +2.775V, +3.3V, +5V, +10V, and +14.2V operating voltages

Input and Output Connections

The following shows the Receiver module input and output external connections.

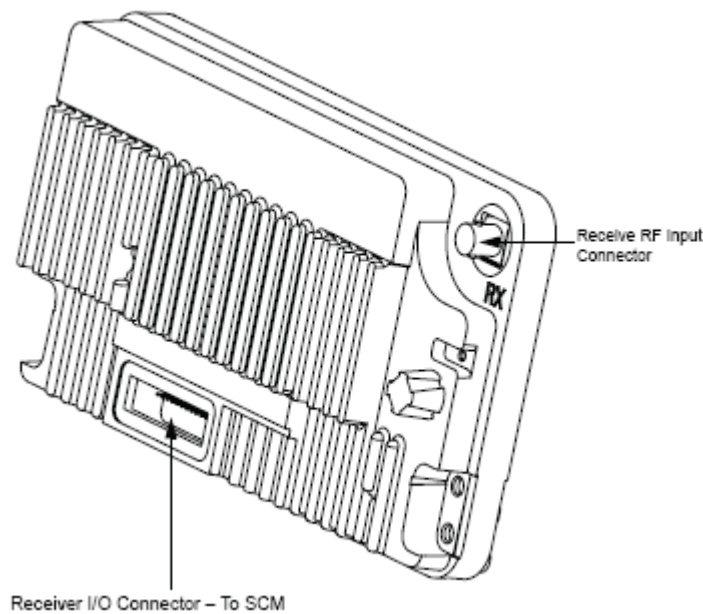

User / Operational Manual

Functional Description / Operation of Modules (Draft)

Specifications

The following table shows the specifications of MTR3000 Base Station / Repeater's Receiver.

| <u>Parameter</u>                      | <u>Specification</u>   |
|---------------------------------------|--|
| Frequency Ranges                      | 136–174 MHz  |
| Electronic Bandwidth                  | Full Bandwidth   |
| Analog Sensitivity 12 dB SINAD        | 0.257 $\mu$ V (-118.8 dBm)   |
| Intermodulation Rejection             | 85 dB  |
| Adjacent Channel Rejection*           | 75 dB at 12 kHz, 80 dB at 25 kHz   |
| Spurious and Image Response Rejection | 85 dB  |
| Intermediate Frequencies              | 1st: 44.85 MHz<br>2nd: 2.25 MHz  |
| Intermod Rejection                    | 85 dB  |
| RF Impedance                          | 50 $\Omega$  |
| Current Draw (Maximum)                | 0.05A from 14.2 VDC supply<br>0.5A from 10 VDC supply<br>0.13A from 8 VDC supply |

Receiver Front End Circuitry

The RF signal enters the Receiver through a BNC-type RF connector, located on the bottom side of the Receiver. The signal is then low-pass filtered, and the 1/2 IF and image frequency are filtered through the tunable preselector. This signal is then amplified using a low-noise amplifier (LNA), and then further filtered to remove the image signal.

Receiver Back End Circuitry

The signal after the image filter is then mixed down to the first IF, via a high performance (high IIP3) mixer, driven by the low-phase noise, voltage-controlled Colpitts oscillator (VCO). The mixed-down signal then passes through a 3-pole, crystal IF bandpass filter and an IF amplifier. The amplifier output signal passes through another 3-pole crystal bandpass filter, and the resultant signal passes through a digital step attenuator. The desired signal is then applied to the RF input of the custom backend Receiver IC.

Voltage Controlled Oscillator (VCO)

The Receiver Voltage Controlled Oscillator (VCO) generates a sinusoidal output signal that ranges from 180.85 MHz to 218.85 MHz. The Receive Voltage-Controlled Oscillator (RXVCO) line-up consists of four sub-circuits: a Voltage-Controlled Oscillator (VCO), an attenuator, a buffer-amplifier, and a low pass filter (LPF).

The active device is from oscillator topology, utilizing a high-Q resonator, and four anti-parallel configured, hyper-abrupt, tuning varactors.

The attenuator provides a broadband RF load for the VCO. The buffer-amplifier provides power leveling and isolation. The LPF provides VCO harmonic attenuation.

Synthesizer Circuitry

The Receiver synthesizer is a subcircuit within a custom IC, which when connected with a loop filter, VCO, buffer amplifier, lowpass filter, driver amplifier, unequal splitter, and feedback attenuator forms a phase-locked loop. The frequency and phase of the VCO is locked to a highly-stable external Temperature Compensated Crystal Oscillator (TCXO) reference (16.8 MHz). The custom IC contains the following integrated Phase locked loop (PLL) components: prescaler, fractional-N divider, reference divider, phase detector, and charge-pump (for the external loop-filter). The reference divider frequency is selected depending on the frequency band of operation, and will range from 3.36 MHz to 16.8 MHz.

*Functional Description / Operation of Modules (Draft)***Custom Backend Receiver IC Circuitry**

The custom backend Receiver IC provides additional amplification, filtering, and a second downconversion. The second IF signal is converted to a digital signal, and output via either a differential or single-ended driver to the digital signal processor (DSP) in the SCM.

**Memory Circuitry**

The memory circuitry consists of an Electrically Erasable Programmable Read-Only Memory (EEPROM), located in the Receiver. The SCM performs memory read and write operations via the SPI bus. The RX Front-End Filter tuning calibration is stored in the EEPROM. Therefore, no field tuning is ever required for the Receiver.

**Analog to Digital (ADC) Converter Metering Circuitry**

Analog signals from points throughout the Receiver are applied to the ADC converter. These analog signals are converted to digital signals and then sent to the SCM, via the Serial Peripheral Interface (SPI) lines, upon request of the SCM.

**Communications with Station Control Module**

Data communications between the Receiver and the Station Control Module microprocessor ( $\mu$ P) is performed via a Serial Peripheral Interface (SPI) bus. This bus allows the SCM  $\mu$ P to send data to the synthesizer PLL IC (to select frequency) and to read the ADC Converter IC.

**ADC Converter Circuitry**

Analog signals from various strategic operating points throughout the Receiver board are fed to an ADC converter, which converts them to a digital signal and, upon request by the Station Control Module, outputs the signal to the Station Control Module via the Serial Peripheral Interface (SPI) bus.

Functional Description / Operation of Modules (Draft)

Exciter Overview

The Exciter Modules (in conjunction with the Power Amplifier Module) provides the transmitter functions for the station. Contained within a metal clamshell housing, the Exciter board generates a low-level modulated Radio Frequency (RF) signal which is input to the power amplifier module for further amplification and output to the transmit antenna. The Exciter Modules interfaces directly with the Station Control Module (SCM), which provides control signals and monitoring, and routes transmit audio to the Exciter.

The RF carrier is generated by a frequency synthesizer consisting of synthesizer circuitry and Voltage-Controlled Oscillator (VCO) circuitry. Exciter module control signals, monitoring, and audio processing are handled by the Station Control Module (SCM).

The Exciter board contains the following circuitry:

- Frequency Synthesizer Circuitry – consists of a phase-locked loop and Voltage-Controlled Oscillator (VCO), generates a modulated RF signal at the transmitter carrier frequency
- RF Isolation Switch – allows the SCM to turn on/off the Exciter RF output signal to the power amplifier module
- Analog to Digital Converter (ADC) Converter Circuitry – converts the analog Exciter status signals to the digital format for transfer, upon request, to the SCM
- Local Power Supply Regulation/Filtering – accepts +8V, +10V and +14.2V inputs and provides +5V, +10V, and +12V operating voltages
- Low Level Amplifiers – amplify and buffer the modulated RF signal from the VCO for delivery to the power amplifier module

Input and Output Connections - The following shows the Exciter module input and output external connections.

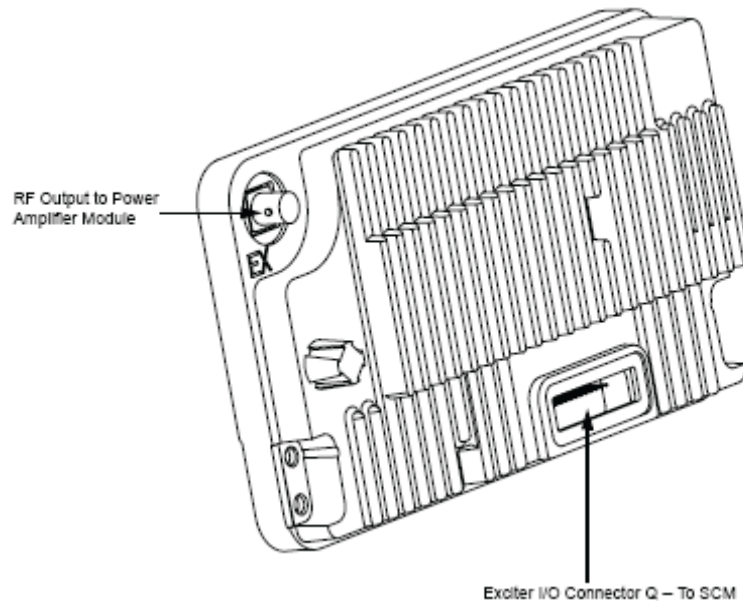

Specifications of Exciter Module

| Parameter              | Specification  |
|------------------------|--|
| Frequency Ranges       | 136–174 MHz  |
| Electronic Bandwidth   | Full Bandwidth   |
| Output Power           | 12–16 dBm  |
| Current Draw (Maximum) | 0.05A from 14.2 VDC supply<br>0.15A from 10 VDC supply<br>0.1A from 8 VDC supply |
| Harmonics              | -20 dBc  |

**User / Operational Manual***Functional Description / Operation of Modules (Draft)*

## Functional Theory of Operation

The following theory of operation describes the operation of the Exciter circuitry at a functional level. The information is presented to give the service technician a basic understanding of the functions performed by the module in order to facilitate maintenance and troubleshooting to the module level. Refer to a block diagram of the Exciter module.

## Functional Overview

## Synthesizer and VCO Circuitry

## Phase-Locked Loop

The phase-locked loop (PLL) IC receives frequency selection data from the SCM microprocessor (via the SPI bus). Once programmed, the PLL IC compares a reference frequency signal with a divided-down feedback sample of the VCO output. The reference frequency is selected depending on the frequency band of operation, and will range from 3.36 MHz to 16.8 MHz. Depending on whether the feedback signal is higher or lower in frequency than the reference, up/down correction pulses are generated. The width of these correction pulses depends on the quantitative difference between the reference and the VCO feedback.

The up/down pulses from the PLL IC are fed to a charge pump which outputs a DC voltage proportional to the pulse widths. This DC voltage is then low-pass filtered and fed to the VCO as the control voltage.

## Voltage Controlled Oscillator (VCO)

The DC control voltage from the synthesizer is fed to dual VCOs which generate the RF carrier signal. Within each band, one VCO generates signals in the upper half of the band, while the other VCO generates signals in the lower half of the band. Only one VCO is active at a time. Selection of the active VCO is provided by a VCO\_SELECT signal from the PLL IC.

The active VCO responds to the DC control voltage and generates the appropriate RF signal. This signal is fed through impedance matching, amplification, and filtering and is output to the RF Switch Circuitry. A sample of the output is returned to the PLL IC to serve as a VCO feedback signal.

## Modulation

The Exciter uses dual-port FM modulator consisting of Digital Signal Processor (DSP), PLL low-port and high port blocks, fractional-N PLL, loop filter and the VCO. The modulator is calibrated once during factory test and its values are stored in the EEPROM. The modulator does not require any further tuning or maintenance.

## Amplifiers

The amplifiers consist of a driver amplifier and the final amplifier. The driver amplifier operates from a nominal 5V supply and the final amplifier operates from a nominal 10V supply. The driver amplifier amplifies the VCO output signal and provides the output signal to the final amplifier. There are fixed attenuators at the output of the driver and final amplifier to set the Exciter output power level. The final amplifier amplifies the signal and provides a constant signal level to the PA.

## RF Switch Circuitry

The modulated RF signal from the VCO is fed through a buffer, driver, and attenuator and finally to an RF switch circuit. Signal EX\_ENABLE from the SCM controls the switch and final amplifier. The RF signal is passed through a LPF and to a BNC connector mounted in one corner of the module, just outside the module cover. A short coaxial cable connects the Exciter output to the power amplifier module.

*Functional Description / Operation of Modules (Draft)***Communications with Station Control Module**

Data communications between the Exciter and the Station Control Module microprocessor ( $\mu\text{P}$ ) is performed via a Serial Peripheral Interface (SPI) bus. This bus allows the SCM  $\mu\text{P}$  to send data to the synthesizer PLL IC (to select frequency) and to read the ADC Converter IC.

**ADC Converter Circuitry**

Analog signals from various strategic operating points throughout the Exciter board are fed to an ADC converter, which converts them to a digital signal and, upon request by the Station Control Module, outputs the signal to the Station Control Module via the Serial Peripheral Interface (SPI) bus.

**Voltage Regulation/Filtering Circuitry**

The voltage regulator circuitry consists of a +5V, +3.3V and +2.775V regulators that supplies power to the digital circuitry and the PLL. The +12V regulator is used to supply power to the VCO and the +10V supplies power to the final device.

User / Operational Manual

Functional Description / Operation of Modules (Draft)

Power Amplifier Module Overview

The Power Amplifier (PA) is a forced convection-cooled RF power amplifier. It accepts a low-level modulated RF signal from the Exciter Module, and amplifies it for transmission via the site transmit antenna port. The PA is non-linear, and is therefore used for continuous wave (CW) applications only. The output power is continually monitored and regulated by a feedback and control loop, with a power output control voltage being generated by the transmitter control circuitry located on the PA Input/Output boards.

Overview of Circuitry

The Power Amplifier contains the following sub-circuits:

- DC Distribution Board – main interface for the PA to the Station Control Module (SCM) and Power Supply (PS). This board contains PA SPI circuits including Analog to Digital Converter (ADC), Digital to Analog Converter (DAC), and Non-Volatile Memory (NVM) devices, and hardware (HW) metering circuitry
- RF Board – provides RF signal amplification from the Exciter Module low-level signal to the BR output power level
- Isolator – protects the PA from damage when poor RF load conditions exist. Also assists with intermodulation attenuation performance
- Output Board – performs harmonic filtering and RF power detection functions, and routes the RF signal to the antenna port

Input and Output Connections

The following shows the PA input and output external connections.

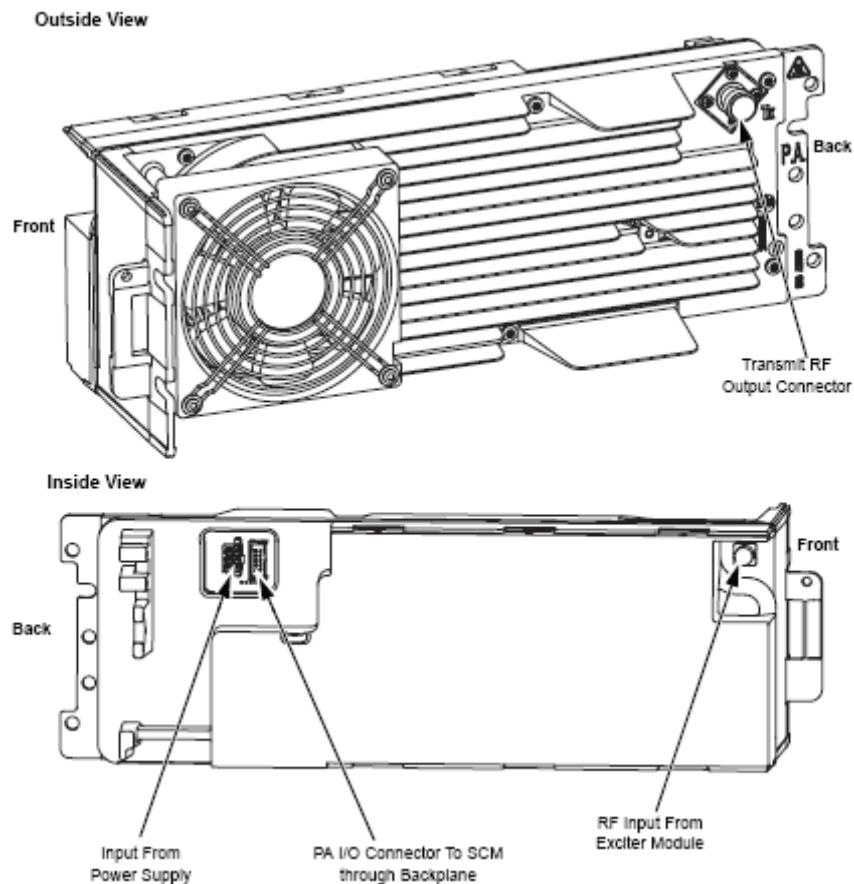

*Functional Description / Operation of Modules (Draft)*

The following table shows the specifications of MTR3000 Power Amplifier (PA).

*Specifications of Power Amplifier*

| <b>Parameter</b>                        | <b>Specification</b> |
|---|----------------------|
| Operational Frequency Range             | 136–174 MHz          |
| Minimum Input Return Loss (TX mode)     | 10 dB                |
| Rated RF Output Power Range             | 8–100 W              |
| Rated RF Input Power Range              | 11.8–16 dBm          |
| 28.6V Supply Nominal Voltage (AC Power) | 28.6V (+/- 4%)       |
| 14.2V Supply Nominal Voltage            | 14.2V (+/- 3%)       |
| 28.6V Supply Maximum Current Draw       | 12.6A                |
| 14.2V Supply Maximum Current Draw       | 2.0A                 |
| Maximum Standby Power Consumption       | 1.5 W                |

**Functional Theory of Operation**

The Power Amplifier (PA) is designed for continuous-duty operation across each specified band and power level. All PA contain a multi-stage power amplifier board at the input (RF Board), a circulator with isolation load termination, a low-pass filter/directional coupler at the output (Output Board), and a DC Distribution Board incorporating circuitry for diagnostics and RF power control. The PA and its sub-circuits are broad-band devices and require no manual tuning or alignment to operate over the specified conditions.

The main interface between the PA and the rest of the BR is through the DC Distribution Board. The DC distribution board contains the PA external I/O's that connects to the power supply directly through a cable and to the control module through a cable to the backplane. These I/O's are used to distribute the DC supply buses (28.6V and 14.2V nominal) from the power supply to within the PA as well as the various signals used for the control of the PA from the SCM such as the SPI bus signals, PA enable, and the reset line.

The DC Distribution Board contains the SPI circuitry as well as metering circuitry used by both SW and internal PA HW for determining when fault conditions are present and take appropriate action when needed. A brief description of the PA SPI devices is shown below:

- Customer Programmable Logic Device (CPLD): main PA SPI interface, with all other PA SPI devices connected through this device
- Non-Volatile Memory (NVM): used to store calibration data and identification information
- Digital to Analog Converter (DAC): converts SW digital signals to analog within the PA. This controls the PA fan, power control circuit, and some other circuits within the PA
- Analog to Digital Converter (ADC): converts analog signals within the PA to digital for SW interface. These signals are used by SW for HW metering

A combination of software (SW) and hardware (HW) controls are used to regulate the PA RF output power level. By way of software control, the SCM programs RF output power through the SPI bus. Once programmed, the PA power control loop will level the output power to the requested level, if possible. The requested output power may not be achievable if an alarm condition is present, and output power may be reduced by way of SW or HW control if alarm conditions are present.

Within the Base Station / Repeater (BR), the modulated RF signal passes from the Exciter Module to the driver amplifier within the PA. The driver amplifier is located on the RF Board and is a multi-stage amplifier circuit that amplifies the RF input signal up to a maximum of approximately 4 W, as needed to achieve the software requested BR RF output power. The RF signal from the driver amplifier is further amplified by the final amplifier stage, which is also located on the RF Board and consists of multiple paralleled RF devices with associated splitting and combining circuitry.

This RF signal then passes through a circulator and harmonic (low pass) filter, through an RF directional coupler, and is output to the site transmit antenna port. The circulator prevents a high Voltage Standing Wave Ratio (VSWR) at the PA output from damaging the final amplifier devices, and also improves intermodulation attenuation (IMA) performance by providing isolation to the final amplifier. The harmonic filter attenuates the harmonic levels generated by the preceding RF amplifier devices.

The RF directional coupler is a calibrated wattmeter, with its calibration information stored in the PA NVM. The forward and reverse power wattmeter provides a signal corresponding to the measured output power to the ADC



*Functional Description / Operation of Modules (Draft)*

for metering purposes so that SW can monitor the PA/BR output power. Also, this voltage is provided to the power control circuitry within the PA to serve as the feedback signal in the power control loop for setting output power. The forward power meter along with the reverse power meter is used by SW to measure the VSWR presented to the PA output and to determine when an alarm condition is present.

The SW requested power level may include one or more SW controlled adjustments based on various alarm conditions, if present, generated from monitored PA metering signals which are fed back to the SCM via an ADC converter. Using the ADC metering circuitry, SW monitors the PA for alarm conditions, such as high reflected power/VSWR, high temperature, high/low supply voltage, fan failure, low PA gain, and RF control loop instability and takes action to reduce output power or dekey the station accordingly in order to protect the HW from damage or improper operation.

Temperature monitoring circuitry is also contained within the PA. When the temperature reaches a certain threshold, the PA fan turns on to reduce the operating temperature of the PA. If the temperature continues to rise and reaches another predefined threshold, the BR output power may also be reduced in order to protect the HW from thermal failure. Both the fan control and the power control manipulation for thermal protection is fully HW controlled, and requires no SW interaction.

User / Operational Manual

Functional Description / Operation of Modules (Draft)

Power Supply Module Overview

The Power Supply is described in this section. The information provided is sufficient to give service personnel a functional understanding of the module, allowing maintenance and troubleshooting to the module level. (Refer to the service manual for Maintenance and Disassembly/Reassembly Procedures for detailed removal or installation procedures for all modules in the station.)

The Power Supply has built in power factor correction and includes a connection for battery backup that also serves as the DC input when the supply is used in DC only input mode.

The Power Supply accepts an AC or a DC input (AC input = 85 to 264 VAC, 50/60 Hz, DC input = 21.6 to 32 VDC) and generates three output DC voltages to power the station modules: +28.6 VDC, +14.2 VDC and +5.1 VDC.

Note: When used in DC input mode, the 28.6 VDC output equals the DC input within 0 to -0.5 VDC.

Note: An external 24V (nominal) battery system is required to support the battery backup feature so that when the AC power fails, the BR can be powered from a DC battery source if it is connected to the PS. This results in uninterrupted radio service (for as long as battery power can be provided). As the PS does not have a battery charging function, when the AC power is restored, an external charger is required to recharge the battery.

The power supply is a high-frequency switched mode design, all contained in a metal heat-sink, and mounted on the left-hand side of the station. The design provides for output over-voltage/overcurrent protection.

The AC input connection is made at the rear of the station via an IEC-type connector keyed to accept only high temperature type mating connectors. Also provided is a Battery Backup connection (see DC mode above). Power supply cooling, when necessary, is provided by an external fan (located near the middle of the heatsink) which provides forced air across the power supply heatsink fins.

The following shows the electrical performance specifications for the power supply.

Power Supply Module AC Performance Specification:

| Parameter  | Value or Range  |
|--|---|
| Input Voltage Range                                  | 85 VAC to 264 VAC   |
| Input Frequency Range                                | 47–63 Hz  |
| Steady State Output Voltage                          | 28.6 V @ 13 A,<br>14.2 V @ 8 A,<br>5.1 V @ 2 A                                    |
| Output Power (Rated)                                 | 500 W   |
| Output Ripple:<br>+28.6 VDC<br>+14.2 VDC<br>+5.1 VDC | 50 mV p-p, @ 25°C (77°F)<br>50 mV p-p, @ 25°C (77°F)<br>100 mV p-p, @ 25°C (77°F) |

Power Supply Module DC Performance Specification:

| Parameter  | Value or Range   |
|--|--|
| Input Voltage Range                                  | 21.6 - 32 VDC  |
| Steady State Output Voltage                          | 28.6 V @ 13 A, Input Voltage Dependent<br>14.2 V @ 8 A, Regulated<br>5.1 V @ 2 A, Regulated          |
| Output Power (Rated)                                 | 500 W  |
| Output Ripple:<br>+28.6 VDC<br>+14.2 VDC<br>+5.1 VDC | Input Voltage Dependent, 0-0.5V below input<br>50 mV p-p, @ 25°C (77°F)<br>100 mV p-p, @ 25°C (77°F) |