

APPLICANT: Motorola Solutions

EQUIPMENT TYPE: ABZ89FC5840

## **User Information**

### **User Information**

Installation and Configuration Guide follows.



# Installation and Configuration Guide

# Intellectual Property and Regulatory Notices

## Copyrights

The Motorola Solutions products described in this document may include copyrighted Motorola Solutions computer programs. Laws in the United States and other countries preserve for Motorola Solutions certain exclusive rights for copyrighted computer programs. Accordingly, any copyrighted Motorola Solutions computer programs contained in the Motorola Solutions products described in this document may not be copied or reproduced in any manner without the express written permission of Motorola Solutions.

No part of this document may be reproduced, transmitted, stored in a retrieval system, or translated into any language or computer language, in any form or by any means, without the prior written permission of Motorola Solutions, Inc.

## Trademarks

MOTOROLA, MOTO, MOTOROLA SOLUTIONS, and the Stylized M Logo are trademarks or registered trademarks of Motorola Trademark Holdings, LLC and are used under license. All other trademarks are the property of their respective owners.

## License Rights

The purchase of Motorola Solutions products shall not be deemed to grant either directly or by implication, estoppel or otherwise, any license under the copyrights, patents or patent applications of Motorola Solutions, except for the normal non-exclusive, royalty-free license to use that arises by operation of law in the sale of a product.

## Open Source Content

This product may contain Open Source software used under license. Refer to the product installation media for full Open Source Legal Notices and Attribution content.

## European Union (EU) Waste of Electrical and Electronic Equipment (WEEE) directive



The European Union's WEEE directive requires that products sold into EU countries must have the crossed out trash bin label on the product (or the package in some cases).

As defined by the WEEE directive, this cross-out trash bin label means that customers and end-users in EU countries should not dispose of electronic and electrical equipment or accessories in household waste.

Customers or end-users in EU countries should contact their local equipment supplier representative or service centre for information about the waste collection system in their country.

## Disclaimer

Please note that certain features, facilities, and capabilities described in this document may not be applicable to or licensed for use on a specific system, or may be dependent upon the characteristics of a specific mobile subscriber unit or configuration of certain parameters. Please refer to your Motorola Solutions contact for further information.

© 2021 Motorola Solutions, Inc. All Rights Reserved

# Contact Us

The Solutions Support Center (SSC) is the primary contact for technical support included in your organization's service agreement with Motorola Solutions.

Service agreement customers should be sure to call the SSC in all situations listed under Customer Responsibilities in their agreement, such as:

- Before reloading software
- To confirm troubleshooting results and analysis before taking action

Your organization received support phone numbers and other contact information appropriate for your geographic region and service agreement. Use that contact information for the most efficient response. However, if needed, you can also find general support contact information on the Motorola Solutions website, by following these steps:

- 1 Enter [motorolasolutions.com](https://motorolasolutions.com) in your browser.
- 2 Ensure that your organization's country or region is displayed on the page. Clicking or tapping the name of the region provides a way to change it.
- 3 Select "Support" on the [motorolasolutions.com](https://motorolasolutions.com) page.

## Comments

Send questions and comments regarding user documentation to [documentation@motorolasolutions.com](mailto:documentation@motorolasolutions.com).

Provide the following information when reporting a documentation error:

- The document title and part number
- The page number or title of the section with the error
- A description of the error

Motorola Solutions offers various courses designed to assist in learning about the system. For information, go to <https://learning.motorolasolutions.com> to view the current course offerings and technology paths.

# Document History

Version	Description	Date
TBD	Early draft of the <i>900 MHz eNodeB Installation and Configuration Guide</i> .	TBD

# Contents

<b>Intellectual Property and Regulatory Notices.....</b>	<b>2</b>
<b>Contact Us.....</b>	<b>3</b>
<b>Document History.....</b>	<b>4</b>
<b>List of Figures.....</b>	<b>7</b>
<b>List of Tables.....</b>	<b>8</b>
<b>List of Processes.....</b>	<b>9</b>
<b>List of Procedures.....</b>	<b>10</b>
<b>About This Manual.....</b>	<b>11</b>
What Is Covered In This Manual?.....	11
Helpful Background Information.....	11
Related Information.....	11
<b>Chapter 1: General Safety Precautions.....</b>	<b>12</b>
<b>Chapter 2: 900 MHz eNodeB Description.....</b>	<b>15</b>
2.1 Rack Level Description.....	15
2.2 Power Amplifier and Low Noise Amplifier Power Supplies.....	15
2.3 LTE Transceiver Power Supplies.....	16
2.4 LTE Base Band Unit Server.....	17
2.5 TEKO DAS Fan Rack.....	18
2.6 TEKO DAS Active Sub-rack.....	19
2.7 LTE Supervision Module.....	19
2.8 External Alarm Module.....	21
2.9 TEKO CPRI/DAS Point of Interface.....	23
2.10 Power Amplifier Fan Shelf.....	24
2.11 Power Amplifier Shelf.....	25
2.12 Duplex Filter.....	26
2.13 Low Noise Amplifier.....	28
2.14 DIN Rail Components.....	28
<b>Chapter 3: Site Preparation and Design.....</b>	<b>30</b>
3.1 Site Preparation.....	30
3.2 Environmental Specifications.....	33
3.3 Power Specifications.....	33
<b>Chapter 4: Hardware Installation.....</b>	<b>34</b>
4.1 Mounting the 900 MHz eNodeB Cabinet to the Floor.....	34
4.1.1 900 MHz eNodeB Cabinet Footprint.....	35

4.2 900 MHz eNodeB Cabinet Grounding.....	35
4.3 RF Antenna Connections.....	36
4.4 Connecting Power to an AC Power Source.....	37

# List of Figures

Figure 1: Warning Label on Hot Modules .....	13
Figure 2: 900 MHz eNodeB Rack Components .....	15
Figure 3: Front View .....	15
Figure 4: Rear View Description .....	16
Figure 5: Dimensions .....	16
Figure 6: DAS Front View .....	17
Figure 7: DAS Rear View .....	17
Figure 8: BBU Front View .....	17
Figure 9: BBU Rear View .....	18
Figure 10: TEKO DAS Unit – Front View .....	18
Figure 11: TEKO DAS Unit – Rear View .....	18
Figure 12: TEKO DAS Active Sub-rack – Front View .....	19
Figure 13: TEKO DAS Active Sub-rack – Rear View .....	19
Figure 14: LTE Supervision Module .....	20
Figure 15: External Alarm Module .....	22
Figure 16: TEKO CPRI/DAS Point of Interface Front Panel .....	24
Figure 17: Power Amplifier Fan Shelf .....	25
Figure 18: Power Amplifier Shelf .....	26
Figure 19: Duplex Filter .....	27
Figure 20: Multicoupler/LNA .....	28
Figure 21: DIN Details .....	29
Figure 22: 900 MHz eNodeB Cabinet Dimensions .....	31
Figure 23: 900 MHz eNodeB Cabinet Dimensions .....	32
Figure 24: 900 MHz eNodeB Cabinet Footprint .....	35
Figure 25: 900 MHz eNodeB Cabinet Grounding .....	36
Figure 26: Antenna Connection Locations .....	37



# List of Tables

Table 1: Motorola Documentation .....	11
Table 2: Rear View Description .....	16
Table 3: DAS Front View Description .....	17
Table 4: DAS Rear View .....	17
Table 5: TEKO DAS Unit Description .....	18
Table 6: LTE Supervision Module Connectors .....	20
Table 7: LTE Supervision Module LEDs .....	21
Table 8: External Alarm Module Connectors .....	22
Table 9: External Alarm Module LEDs .....	23
Table 10: Power Amplifier Specifications .....	25
Table 11: Duplex Filter Parameters .....	27
Table 12: Cabinet Weight .....	30
Table 13: Server Environmental Specifications .....	33
Table 14: Other Modules Environmental Specifications .....	33
Table 15: Power Requirements .....	33
Table 16: Power Consumption .....	33

# List of Processes

# List of Procedures

Mounting the 900 MHz eNodeB Cabinet to the Floor .....	34
Connecting Power to an AC Power Source .....	37

# About This Manual

This manual provides description of the 900 MHz eNodeB components along with installation and configuration procedures.

## What Is Covered In This Manual?

To be disclosed.

## Helpful Background Information

Motorola Solutions offers various courses designed to help with learning about the system. For more information, go to <https://learning.motorolasolutions.com/> to view the current course offerings and technology paths.

## Related Information

It is recommended that you obtain access to the following documentation. Unless otherwise specified, the Motorola Solutions documents listed here are available to users with a login account at <https://learning.motorolasolutions.com>.

Table 1: Motorola Documentation

Related Information	Purpose
<i>LXN 7100/LXN 7900 LTE Infrastructure Deployment and Maintenance Guide</i>	Provides functional overview and procedures for the LXN 7100 and LXN 7900 LTE Infrastructure.
<i>Standards and Guidelines for Communication Sites R56</i>	This manual provides Motorola Solutions requirements and guidelines for the installation of communications equipment, infrastructure, and facilities. This manual is primarily based on recognized industry codes and standards.

## Chapter 1

# General Safety Precautions

## FCC/ISED Compliance Guidelines



**WARNING:** Compliance with FCC/ISED guidelines for human exposure to Electromagnetic Energy (EME) at Transmitter Antenna sites generally requires that personnel working at a site must be aware of the potential for exposure to EME, and can exercise control of exposure by appropriate means, such as adhering to warning sign instructions, using standard operating procedures (work practices), wearing personal protective equipment, or limiting the duration of exposure. For more details and specific guidelines, see “Appendix A: Electromagnetic Energy Information” of the Motorola Solutions *Standards and Guidelines for Communication Sites* manual.

## Installation guidelines for compliance with RF exposure regulations

This equipment must be installed and operated at a fixed location, in compliance with all applicable code requirements. The antenna installation must comply with all applicable building and safety codes. In order to ensure optimal communication performance and compliance with applicable RF exposure limits, it is recommended that the antenna is installed outside the building hosting this equipment, on the roof or on a tower if at all possible.

It is the licensee or site owner responsibility to establish an RF exposure safety program meeting the applicable regulatory requirements concerning RF exposure of working personnel and the general public, implementing actions such as site survey measurements and computational analysis, signage and barriers, site access restrictions, as needed.

## General safety precautions during all phases of operation, service, and repair

Observe the following general safety precautions during all phases of operation, service, and repair of the equipment described in this manual. Follow the safety precautions listed and all other warnings and cautions necessary for the safe operation of all equipment. Due to the danger of introducing additional hazards, do not install substitute parts or perform any unauthorized modifications of equipment.



**NOTE:** The installation process requires preparation and knowledge of the site before installation begins. Review installation procedures and precautions in the Motorola Solutions *Standards and Guidelines for Communication Sites* manual before performing any site or component installation.

Always follow all applicable safety procedures, such as Occupational Safety and Health Administration (OSHA) requirements, National Electrical Code (NEC) requirements, local code requirements, and safe working practices. Also, all personnel must practice good judgment. General safety precautions include the following:

- Read and follow all warning notices and instructions marked on the product or included in this manual before installing, servicing, or operating the equipment. Retain these safety instructions for future reference.
- If troubleshooting the equipment while power is on, be aware of the live circuits.
- Do not operate the radio transmitters unless all RF connectors are secure and all connectors are properly terminated.
- Ground all equipment properly in accordance with the Motorola Solutions *Standards and Guidelines for Communication Sites* manual and specified installation instructions for safe operation.
- Slots and openings in the cabinet are provided for ventilation. Do not block or cover openings that protect the devices from overheating.

- Only a qualified technician familiar with similar electronic equipment should service equipment.
- Some equipment components can become hot during operation. Turn off all power to the equipment and wait until sufficiently cool before touching.
- Maintain emergency first aid kits at the site.
- Direct personnel to call in with their travel routes to help ensure their safety while traveling between remote sites.
- Institute a communications routine during certain higher risk procedures where the on-site technician continually updates management or safety personnel of the progress so that help can be dispatched if needed.
- Never store combustible materials in or near equipment racks. The combination of combustible material, heat, and electrical energy increases the risk of a fire safety hazard.
- Equipment installed at the site meeting the requirements of a "restricted access location," per UL 62368-1, is defined as follows: "Access can only be gained by service persons or by a user who has been warned about the possible burn hazard on equipment metal housing. Access to the equipment is by using a tool or lock and key, or other means of security, and is controlled by the authority responsible for the location."



**WARNING:** Burn hazard. The metal housing of the product may become extremely hot. Use caution when working around the equipment.

**Figure 1: Warning Label on Hot Modules**



**WARNING:** DC input voltage must be no higher than 60 VDC. This maximum voltage includes consideration of the battery charging "float voltage" associated with the intended supply system, regardless of the marked power rating of the equipment. Failure to follow this guideline may result in electric shock.

**RF energy burn hazard:** disconnect power in the cabinet to prevent injury while disconnecting and connecting antennas.



**CAUTION:** All Tx and Rx RF cables outer shields must be grounded per Motorola Solutions *Standards and Guidelines for Communication Sites* manual requirements. All Tx and Rx RF cables must be connected to a surge protection device according to the Motorola Solutions *Standards and Guidelines for Communication Sites* manual. Do not connect Tx and Rx RF cables directly to an outside antenna.



**IMPORTANT:** All equipment must be serviced by Motorola Solutions-trained personnel.

## FCC Requirements

Radio frequency (RF) transmitters installed at sites within the US must be in compliance with the following FCC regulations:

- The station licensee shall be responsible for the proper operation of the station at all times and is expected to provide observations, servicing, and maintenance as often as may be necessary to ensure proper operation.
- The transmitter ERP shall not exceed the maximum power specified on the current station authorization.

- The frequency of the transmitter must be checked during initial installation of the transmitter, when replacing modules, or when making adjustments that affect the carrier frequency or modulation characteristics.

This equipment has been tested and found to comply with the limits for a Class A digital device, according to part 15 of the FCC Rules. These limits are designed to provide reasonable protection against harmful interference to radio communications when the equipment is operated in a commercial environment.

This equipment generates, uses, and can radiate radio frequency energy. If not installed properly and used in accordance with the instruction manuals, the equipment may cause harmful interference to radio communications. Operation of some compliant equipment in a residential area may cause harmful interference to radio communications, in which case the user is required to correct the interference.

**Notice to Users (FCC)**

This device complies with Part 15 of the FCC rules per the following conditions:

- This device may not cause harmful interference.
- Changes or modifications made to this device, not expressly approved by Motorola Solutions, could void the authority of the user to operate this equipment.

## Chapter 2

# 900 MHz eNodeB Description

900 MHz eNodeB is an optional component that can be integrated into the LXN 7900 LTE infrastructure.

### 2.1

## Rack Level Description

The 900 MHz eNodeB contains all parts necessary for establishing connection between the LTE core and the transmit/receive antenna. All AC connections are located on the top panel of the rack and all, Network and RF Antenna connections pass through the top panel of the rack.

**Figure 2: 900 MHz eNodeB Rack Components**

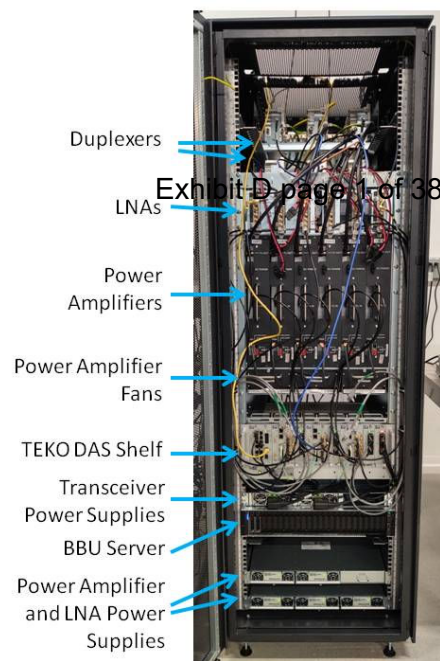

### 2.2

## Power Amplifier and Low Noise Amplifier Power Supplies

The power amplifiers and LNAs are supplied with 48V DC via the AC/DC power supplies located at the bottom of the rack. The number of modules contained in the shelves depends on the number of sectors that are supported. The rack contains enough power supplies to support n+1 redundancy, meaning that if a module were to fail, the remaining modules would be sufficient to support the load.

**Figure 3: Front View**





**Figure 4: Rear View Description**

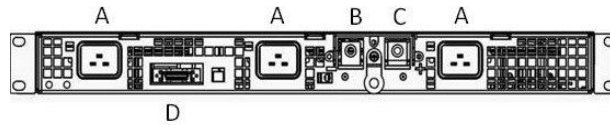

**Table 2: Rear View Description**

Component	Description
A	IEC320 C20 AC Socket
B	DC Return
C	+48V DC

**Figure 5: Dimensions**

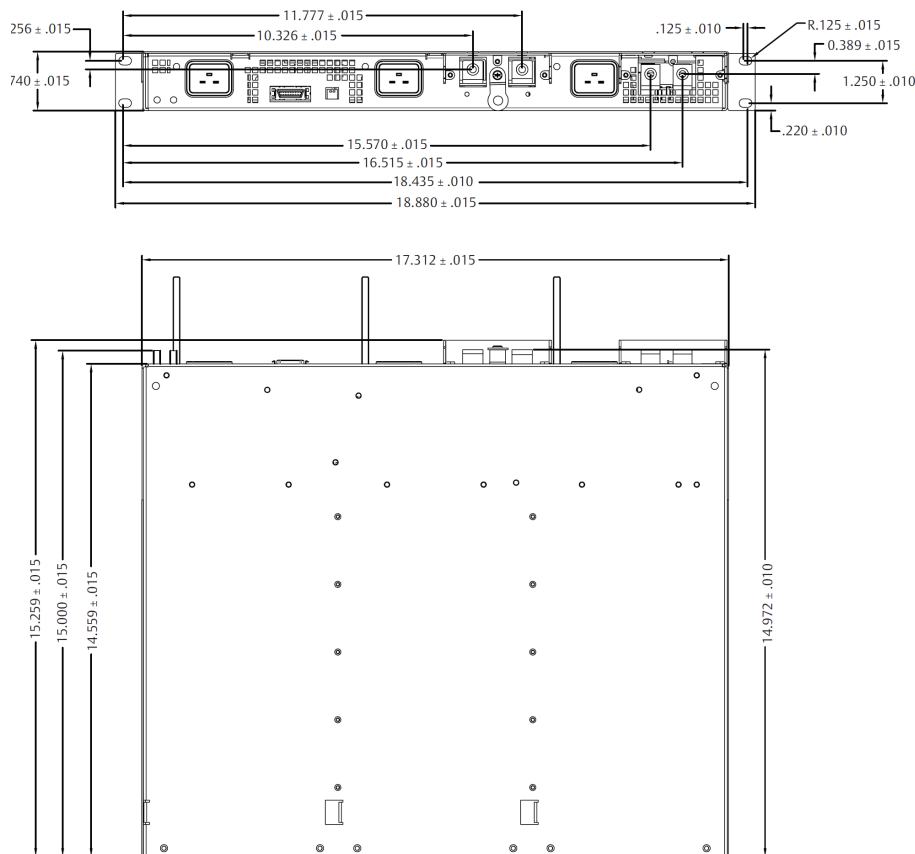

2.3

**LTE Transceiver Power Supplies**

Immediately above the power supplies for the power amplifiers and LNA, are the power supplies for the LTE transceiver shelf. These power supplies are AC/DC converters which supply 24V to the transceiver shelf. The connections to the transceiver shelf are both in the front to the rack and in the rear. The supply output to supply the transceiver is connected in the back and the connection for the shelf health monitoring is made in the front of the rack. Figures 4 and 5 show these connections.

For full specifications, see *TEKO DAS Platform - Master Unit Components*.

**Figure 6: DAS Front View**



**Table 3: DAS Front View Description**

Connectors/LEDs	Description
AC MAINS~	AC MAINS socket (100-240Vac)
Label (LEDs):	
AC	ON (green) when AC input is present
DC	OK
	FAIL
	ON (green) when DC output is available
	ON (red) when DC output is unavailable

**Figure 7: DAS Rear View**



**Table 4: DAS Rear View**

Connectors	Description
	Protective earthing terminal
RS485	RJ45 connector for RS485 connection to the Supervision Module
28V <sup>+</sup> ; 10A MAX	28Vdc Outputs (max 10A each)

2.4

**LTE Base Band Unit Server**

The LTE Base Band Unit (BBU) is supplied via AC and has redundant power supplies so it has two AC line cords that need to be plugged in. The Core's S1 is connected to the server in the back of the unit via eno2. The interface to the management software is via en01. Lastly, the connection to the LTE Transceiver rack is via fiber optic cable between the CIPRI card output and the input to the LTE Point of Interface (POI) modules. Each POI represents a separate connection to the server.

**Figure 8: BBU Front View**



**Figure 9: BBU Rear View**



## 2.5 TEKO DAS Fan Rack

The TEKO DAS fan rack is mounted below the TEKO DAS shelf and cools the modules located therein. The air direction is low to high vertically. Power to this rack is supplied from the LTE Transceiver Power Supply and the health monitoring is done with a connection to the supervisory module in the TEKO DAS shelf.

For full specifications, see *TEKO DAS Platform - Master Unit Components*.

**Figure 10: TEKO DAS Unit – Front View**

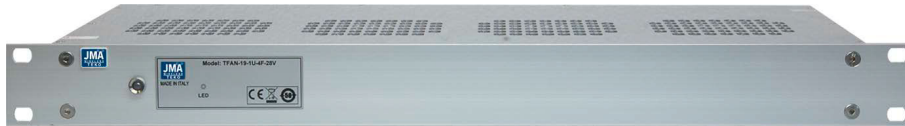

**Figure 11: TEKO DAS Unit – Rear View**

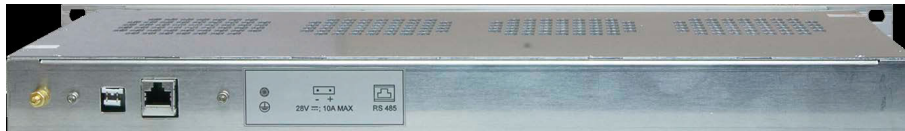

**Table 5: TEKO DAS Unit Description**

Access Point	Description
LED	Forced-air cooling sub-rack general operating LED status: Green: normal operation Blinking Orange: presence of active alarms with warning severity level Orange: presence of active alarms with minor severity level Blinking Red: presence of active alarms with major severity level Red: presence of active alarms with critical severity level
RS485	RJ45 connector for RS485 connection to the Supervision Module
23V <sup>±</sup> ; 10A MAX	23VDC ± 0.5VDC input (max 10A)
	Protective earthing terminal

## 2.6

### TEKO DAS Active Sub-rack

Active Sub-racks are provided with a back plane that allows the management and power supply of active modules.

The following connectors are available on each active sub-rack rear panel:

- A ground bolt, protective earthing terminal
- Up to 5 28Vdc input/output connectors. Each Vdc output connector is protected by a fuse.

For full specifications, see *TEKO DAS Platform - Master Unit Components*.

**Figure 12: TEK0 DAS Active Sub-rack – Front View**



**Figure 13: TEK0 DAS Active Sub-rack – Rear View**

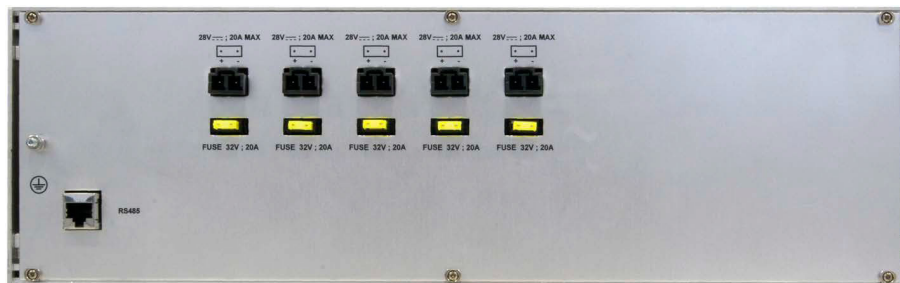

## 2.7

### LTE Supervision Module

The Supervision Module (TSPV) is able to manage other components in the TEK0 DAS shelf. The supervisory intelligence provides automated identity of the deployed system elements, including the identity of all the modules installed within the LTE Transceiver shelf.

The Supervision module provides web-based administration and SNMP v3 support with event based configurations that significantly simplify remote administration (web browser, tablets) and enables integration with SNMP v3 Management tools.

For full specifications, see *TEKO DAS Platform - Master Unit Components*.

**Figure 14: LTE Supervision Module**

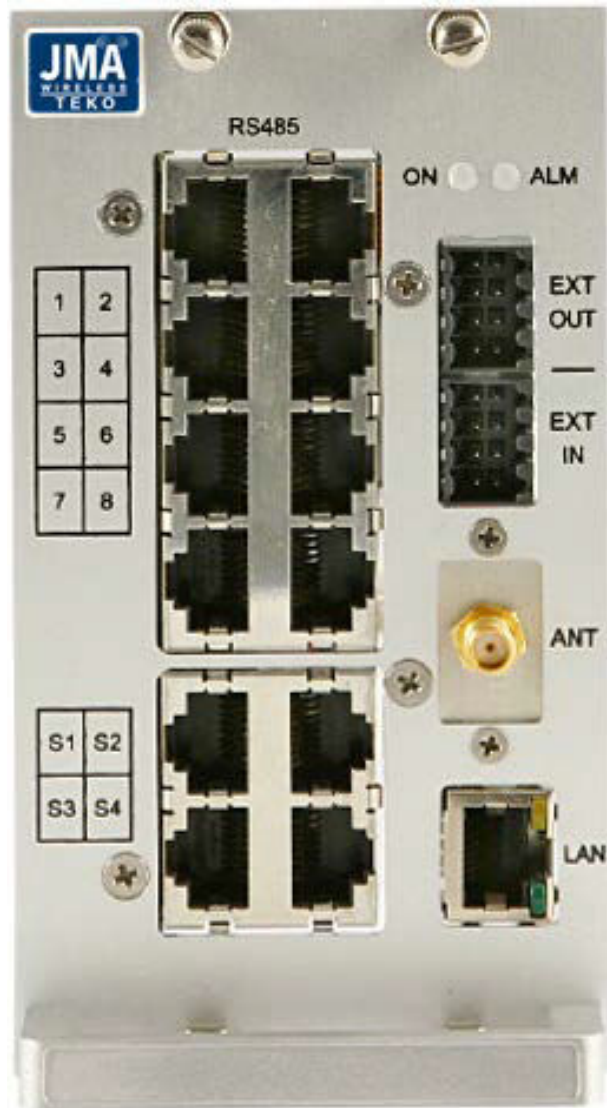

**Table 6: LTE Supervision Module Connectors**

Connectors	Description
RS485 (1 to 8)	RJ45 connectors for the management of monitored Active Sub-racks mounted within the same rack cabinet hosting the Supervision module.
RS485 (S1 to S4)	RJ45 connectors for the management of remote Active Sub-racks equipped with Point-to-Point secondary modules. When not connected to remote Sub-racks, these ports can be used to manage additional Active Sub-racks (exceeding 8) mounted within the same rack cabinet hosting the Supervision module.
EXT OUT	External alarms output connector.

Connectors	Description
EXT IN	External alarms input connector.
RS232 (TSPV-R models)	Factory use only.
ANT	Optional built-in wireless modem antenna SMA connector.
LAN	RJ45 connector Local Control Interface.
WAN (TSPV-Ex models)	RJ45 connector Remote Control Interface.

Table 7: LTE Supervision Module LEDs

LEDs	Description
ON	Supervision Module operating status green LED: ON when power supply is present.
ALM	Supervision Module alarm status LED. OFF: regular operation Blinking Orange: presence of active alarms with warning severity level Orange: presence of active alarms with minor severity level Blinking Red: presence of active alarms with major severity level Red: presence of active alarms with critical severity level

## 2.8

### External Alarm Module

The external alarm module utilizes 16 dry contact inputs to monitor components external to the TEKO shelf. The module is used to monitor the health of the power amplifiers as well as the power amplifier/LNA power supplies. Up to 4 modules can be populated with one per sector and the fourth for the power supplies.

For full specifications, see *TEKO DAS Platform - Master Unit Components*.

**Figure 15: External Alarm Module**

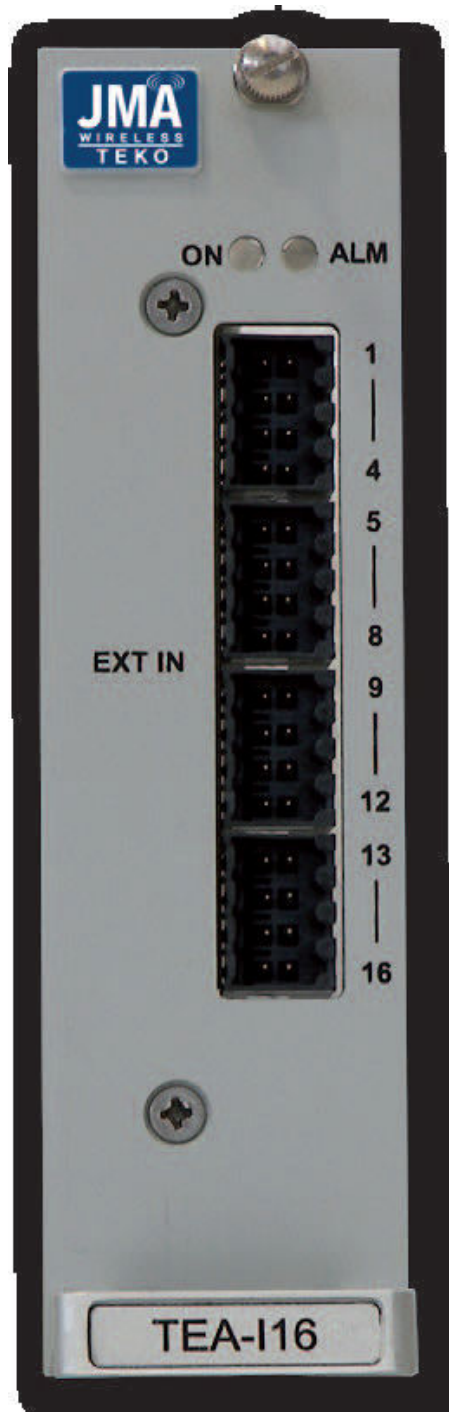

**Table 8: External Alarm Module Connectors**

<b>Connectors</b>	<b>Description</b>
EXT IN	External alarms input connector.
EXT OUT	Optional external alarms output connector (TEA-I1204).

Table 9: External Alarm Module LEDs

LEDs	Description
ON	Alarm Board Module operating status green LED: ON when power supply is present.
	Alarm Board Module alarm status LED. OFF: regular operation Blinking Orange: presence of active alarms with warning severity level Orange: presence of active alarms with minor severity level Blinking Red: presence of active alarms with major severity level Red: presence of active alarms with critical severity level

2.9

## TEKO CPRI/DAS Point of Interface

The TEKO CPRI Point of Interface (POI) is an integrated, low-power, digital RADIO that terminates a CPRI link from an X-RAN Adaptive Baseband server. The TEKO CPRI POI can terminate one/two MIMO carriers or two/four SISO carriers depending on the specific carrier allocation. The CPRI POI performs analog-to-digital (A/D) and digital-to-analog (D/A) conversion and provides low-power analog output/input.

The TCPRI POI is composed of two boards:

- A digital board, converting the digital baseband signals from the X-RAN Adaptive Baseband server into radio frequency (RF) signals.
- An RF board, distributing RF signals from the digital board to the TEKO DAS Platform.

For full specifications, see *TEKO DAS Platform - Master Unit Components*.



**Figure 16: TEKO CPRI/DAS Point of Interface Front Panel**

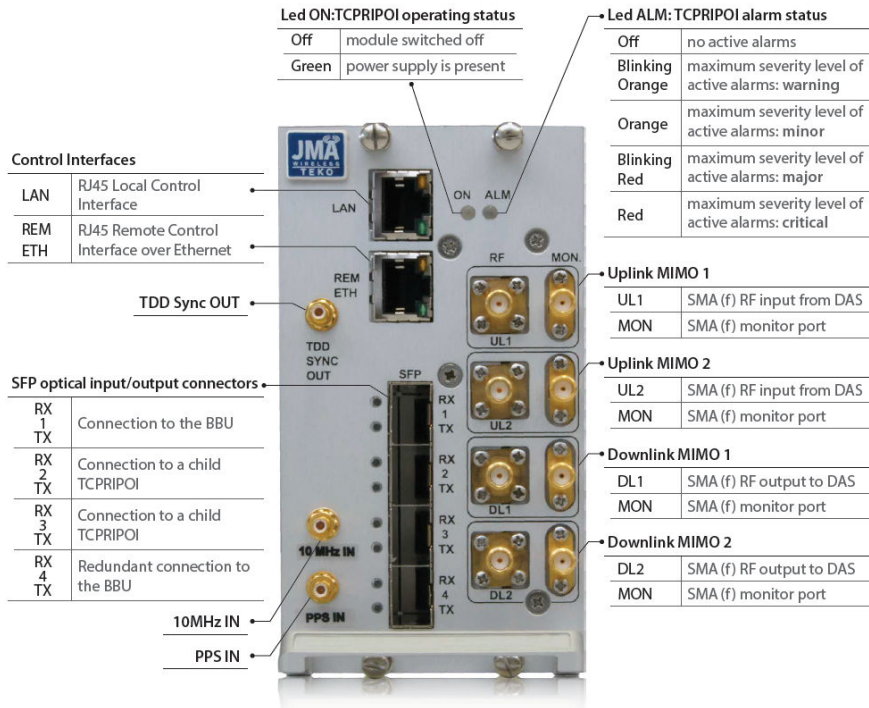

## 2.10 Power Amplifier Fan Shelf

The Power amplifier fan shelf houses three fan kits, each one comprises two fans used to cool the power amplifiers of a single sector. A single fan kit connects to a pair of power amplifiers from which they receive their power and control, and to which they convey any alarms. Redundancy is supplied via control and power supplied from two power amplifiers as well as the fact that each fan kit houses two fans.

**Figure 17: Power Amplifier Fan Shelf**

Parameters:

**521mm x 137mm x 81mm (20.51" x 5.39" x 3.19")**

**4.25 lbs**



2.11

**Power Amplifier Shelf**

The Power amplifier shelf houses up to 6 power amplifiers. This shelf is strictly for mechanical support of the amplifiers and does not electrically connect in any way to the power amplifiers.

The power amplifiers are mounted within the shelf and two power amplifiers are required to support each sector.

48V DC supplies the power amplifier after passing through a 30A circuit breaker.

Once power is applied, an internal FPGA is used to initialize and enable the amplifier as well as to manage the various health monitoring of both the amplifier and the fan kit to which it is attached.

The power amplifier accepts the low level signal from the TEKO shelf and amplifies it nominally by 40dB to a maximum power of 100W at the Tx OUT port. Maximum current is There is no gain or power adjustment available in the amplifier. The drive from the low level transceivers are adjusted in order to achieve the desired power at the top of the rack.

The alarm interface is connected to the external alarm module in the TEKO sub-rack and supplies a dry contact interface.

**Table 10: Power Amplifier Specifications**

	<b>NB1 (standalone)</b>	<b>1.4 MHz LTE</b>	<b>3 MHz LTE</b>
Power (W)	60	100	100

	NB1 (standalone)	1.4 MHz LTE	3 MHz LTE
Current (A)	8.1	10	10
Adj CLR (dB)	50	53	53
Alt CLR (dB)	60	60	60

Physical specifications:

Dimensions: 524mm x 361mm x 72mm (20.63" x 14.21" x 2.83")

Weight: 22.8 lbs

**Figure 18: Power Amplifier Shelf**

Output to duplexer (Tx OUT)

DC Input (DC POWER)

Input from point  
of interface (Tx IN)

Fan Kit Interface (FAN)

Alarm Interface (ENET 2)

Not Used (ENET 1)



## 2.12

### Duplex Filter

The duplex filter is a filter/combiner that allows a single antenna to be used for both the LTE transmit signal as well as the LTE receive signal. The duplexer removes transmitter noise in the receiver sub-band. It also prevents the transmitter signal from entering the multicoupler and receiver at excessive levels.

Two duplex filters are utilized to feed both paths of a single cross polarized antenna or two antenna spaced far enough apart to provide the receiver with two uncorrelated signals.

**Figure 19: Duplex Filter**

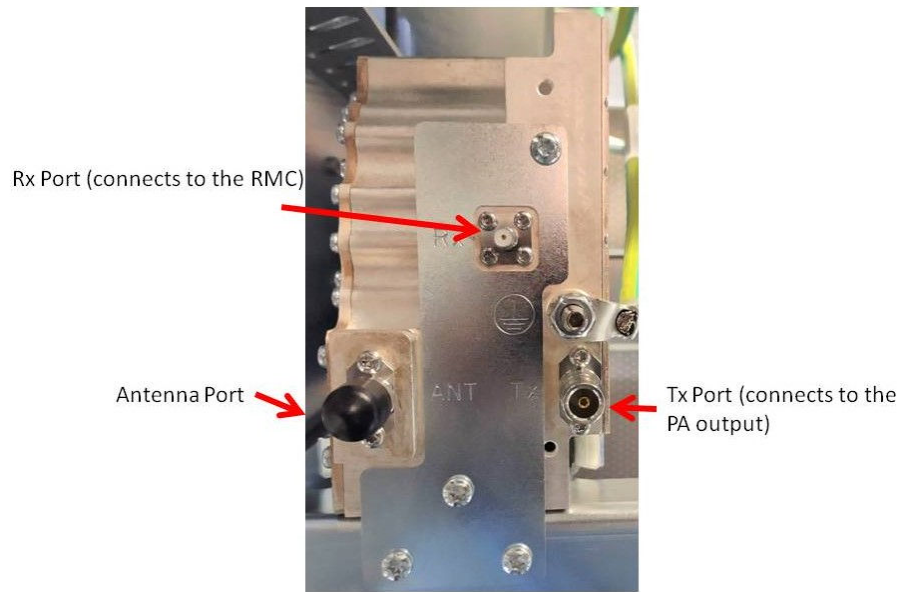

**Table 11: Duplex Filter Parameters**

Parameter	Duplexer Spec Limit	Typical	Comments
TX Frequency Range	935-941 MHz		
RX Frequency Range	896-902 MHz		
Insertion Loss TX	1.3 dB	0.7 dB	
Insertion Loss RX	1.2 dB	0.6 dB	
VSWR Max	1.33:1	1.15:1	
RX Isolation	80 dB	85 dB	
TX Isolation	65 dB	70 dB	
Average Power	120 W		
Peak Instantaneous Power	2.2 kW		
Passive Intermodulation	-120 dBc		2 x 43 dBm
TX & Antenna Connectors	QN		
RX Connector	QMA		
Dimensions	Height: 3.0" (mm)		2 rack units
	Width: 17.2" (mm)		Without cables
	Depth: 17.6" (mm)		

### 2.13

## Low Noise Amplifier

The low noise amplifier is included in a multicoupler unit and gets its signal from the rx port of the duplexer and supplies enough gain to overcome the losses between the duplex filter and the input of the point of interface modules. The gain from the top of the rack to the input of the point of interface is nominally 20dB

The gain is adjusted via the DIP switches located on the front of the receiver multicoupler unit.

12V DC is supplied to one of the multicoupler inputs from the 48V/12V DC/DC converter mounted on the outer edges of the DIN rail assembly. The multicoupler draws a max of 257mA.

Redundancy is supplied by having the LNA of only one MIMO path of each sector connected to the same DC/DC converter. If one converter were to fail, one MIMO path of a sector would still be unaffected.

Physical specifications:

Dimensions: 267mm x 32mm x 125mm (10.51" x 1.26" x 4.92")

Weight: 1.4 lbs

**Figure 20: Multicoupler/LNA**

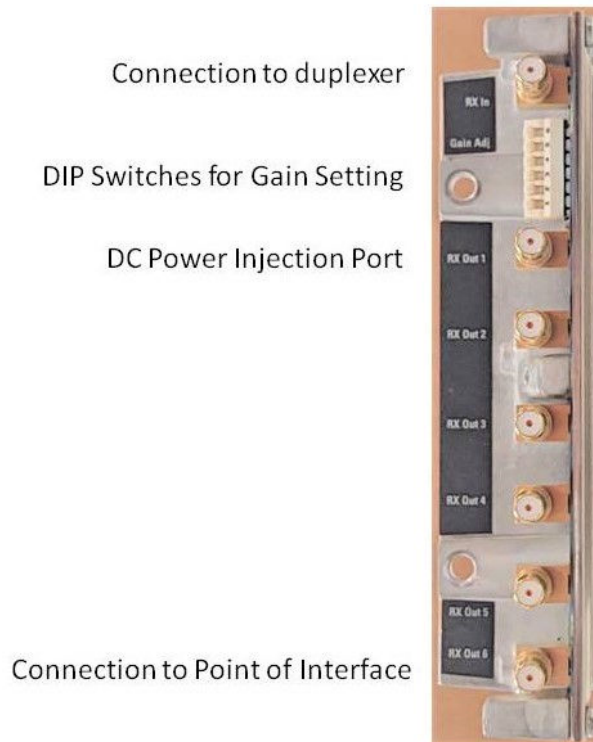

### 2.14

## DIN Rail Components

The DIN Rail located vertically between the BBU and the PA/LNA 48V power supplies and across the back of the rack. It is accessible from the front of the rack.

The DIN Rail holds two LNA 12V converters, 2 associated 6A circuit breakers (one per converter) and six 32A circuit breakers, (one for each power amplifier).

**Figure 21: DIN Details**

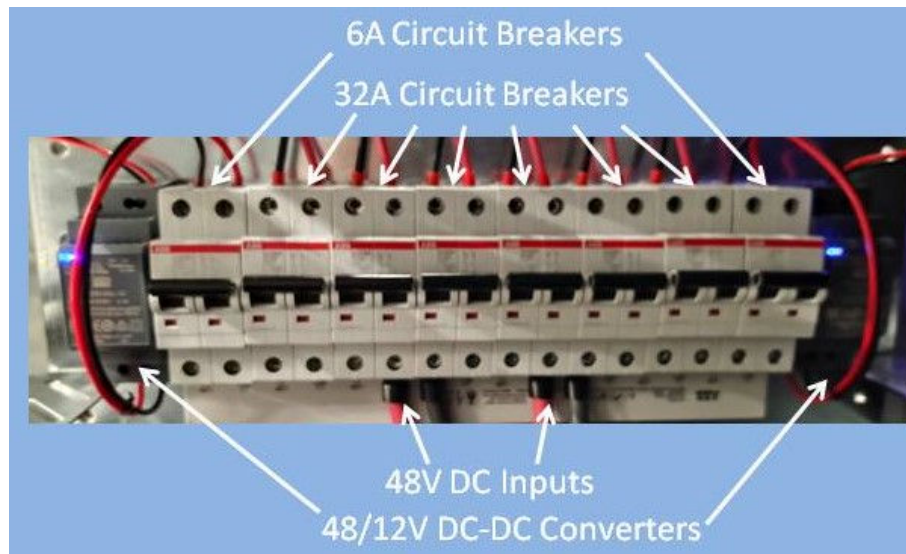

## Chapter 3

# Site Preparation and Design

### 3.1

## Site Preparation

The site should be prepared to accommodate a cabinet of the following dimensions:

- Height: 2083 mm



**NOTE:** The cabinet has adjustable leveling feet. The total cabinet height may vary based on the adjustments to the leveling feet.

- Width: 600 mm
- Depth: 900 mm

The site flooring must withstand the cabinet weight.

Table 12: Cabinet Weight

Cabinet Type	Weight
1 Sector Cabinet	688 lbs (312 kg)
2 Sector Cabinet	775 lbs (352 kg)
3 Sector Cabinet	840 lbs (381 kg)

Figure 22: 900 MHz eNodeB Cabinet Dimensions

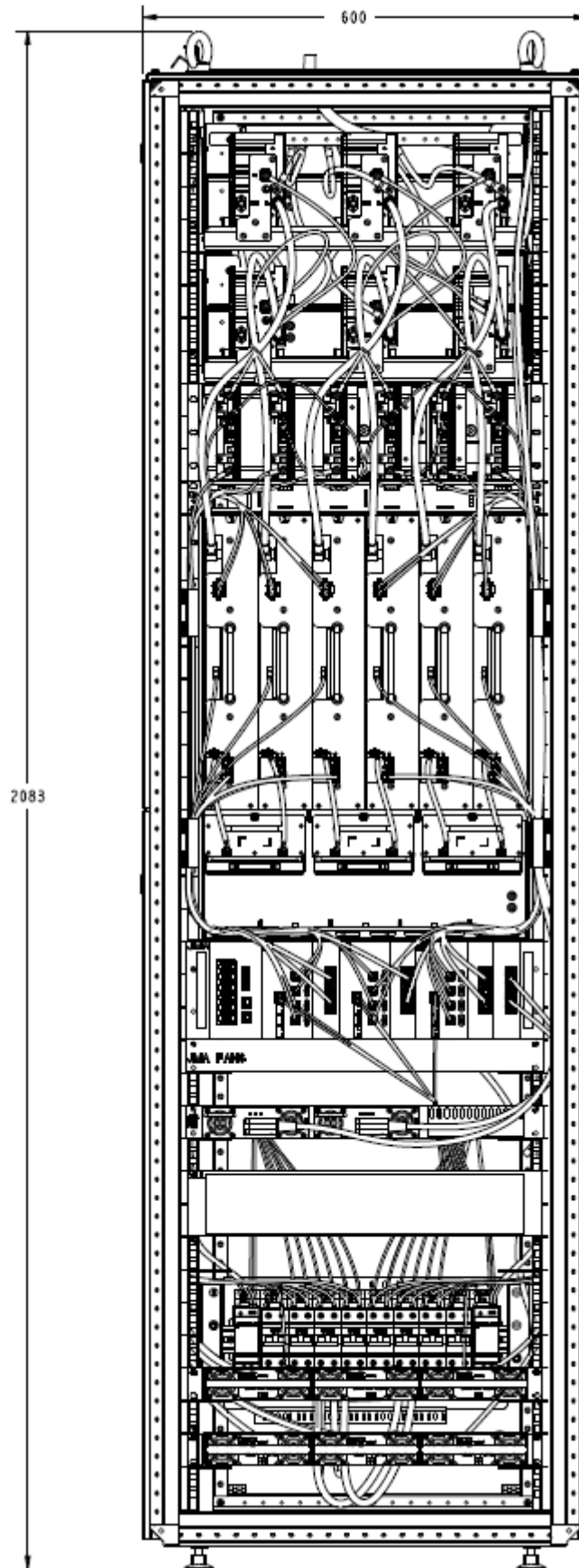



**Figure 23: 900 MHz eNodeB Cabinet Dimensions**

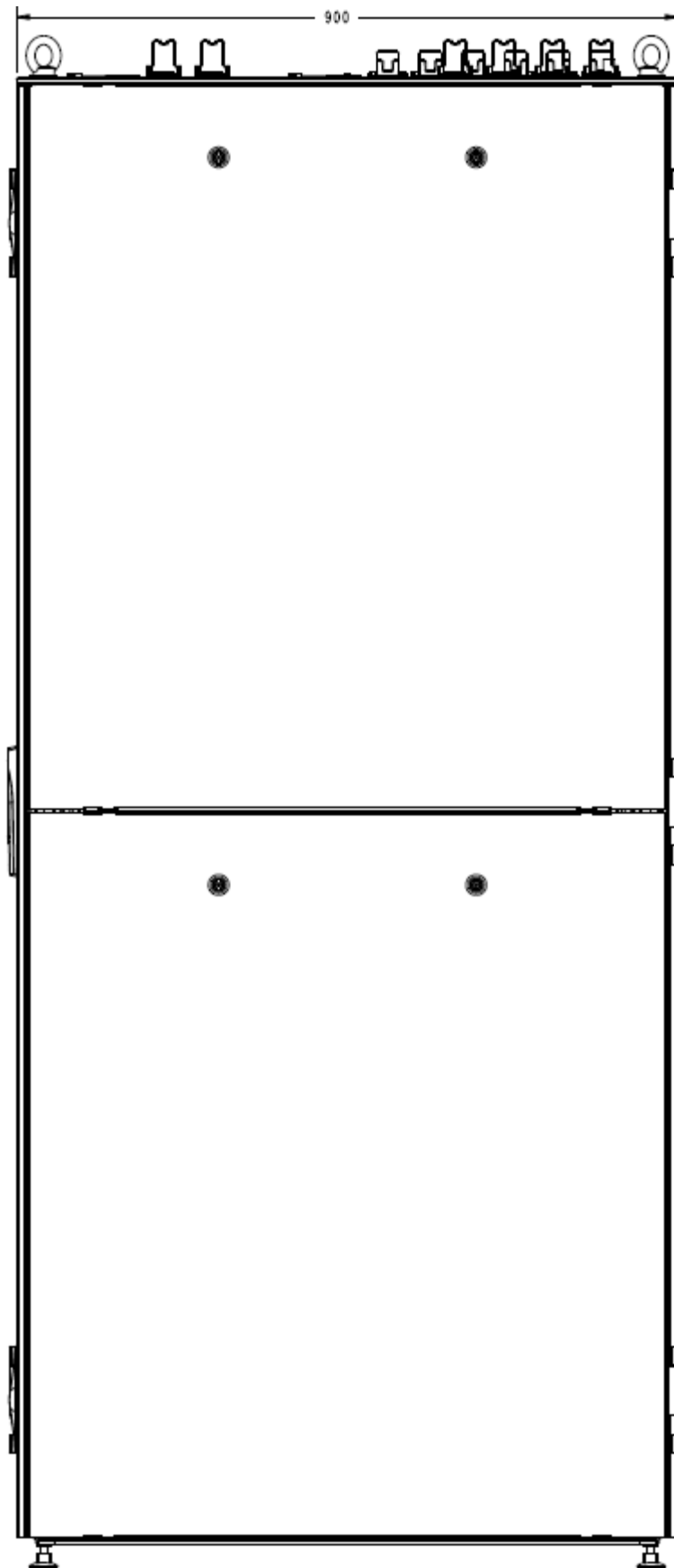

### 3.2 Environmental Specifications

Table 13: Server Environmental Specifications

Characteristic	Value
Operating Temperature	10°C to 35°C
Storage Temperature	-40°C to 65°C
Operational Humidity	
Maximum Altitude	900 m (maximum temperature decrease 1°C/300 m above 900 m)

Table 14: Other Modules Environmental Specifications

Characteristic	Value
Operating Temperature	5°C to 40°C
Storage Temperature	-40°C to 85°C
Operational Humidity	5% to 90% (non-condensing)
Maximum Altitude	1800 m

### 3.3 Power Specifications

Table 15: Power Requirements

Power	Module	Power Requirements
AC	Power Supply Unit	90-264 V, 47-63 Hz
AC	Server	100-240 V, ~50/60Hz
AC	Transceiver	85-264 V, 50-60Hz

Table 16: Power Consumption

Site Configuration	Maximum Current	Typical Power Consumption
1 Sector	12.7 A	1400 W
2 Sector	22.8 A	2500 W
3 Sector	32.8 A	3612 W

## Chapter 4

# Hardware Installation

This chapter contains information and procedures necessary for installing the 900 MHz eNodeB cabinet.

For details on rack installation, including seismic procedures, see the Motorola Solutions *Standards and Guidelines for Communication Sites R56* manual.

For details on safety precautions, see [General Safety Precautions on page 12](#).

### 4.1

## Mounting the 900 MHz eNodeB Cabinet to the Floor

**Prerequisites:** Obtain:

- Anchors



**IMPORTANT:** If securing the rack to a concrete floor, use 1/4-inch grade 8 bolts with anchors.

- Hammer drill and bit
- Cabinet footprint (see [900 MHz eNodeB Cabinet Footprint on page 35](#))



**IMPORTANT:** Sites in seismic active areas may require additional bracing of the equipment cabinets or racks. This manual does not contain specific procedures related to seismic bracing. For further information, see the Motorola Solutions *Standards and Guidelines for Communication Sites R56* manual.

**Procedure:**

- 1 Carefully mark the mounting holes with a pencil as indicated on the rack footprint.
- 2 With a hammer drill and bit, drill the marked hole to the appropriate depth of the mounting hardware.
- 3 Insert an anchor into the drilled hole.
- 4 Tap the anchor into place by using the hammer.
- 5 Carefully move the rack into the position indicated by the holes in the floor.



**DANGER:** Equipment racks are heavy and may tip. Use extreme caution when moving. Lift from top eye nuts with the appropriate apparatus, or secure the rack against tipping if lifting from the bottom. Failure to do so could result in death, serious injury or equipment damage.

- 6 Adjust and level the cabinet feet using a hex driver or allen wrench from inside the cabinet to align the mounting holes with the drilled holes. Each cabinet foot should be in direct contact with the floor.
- 7 Secure the cabinet or rack to the site floor with the locally procured mounting hardware. Re-use the load spreading washers that were used to assemble the lag bolts to the pallet.

### 4.1.1 900 MHz eNodeB Cabinet Footprint

Figure 24: 900 MHz eNodeB Cabinet Footprint

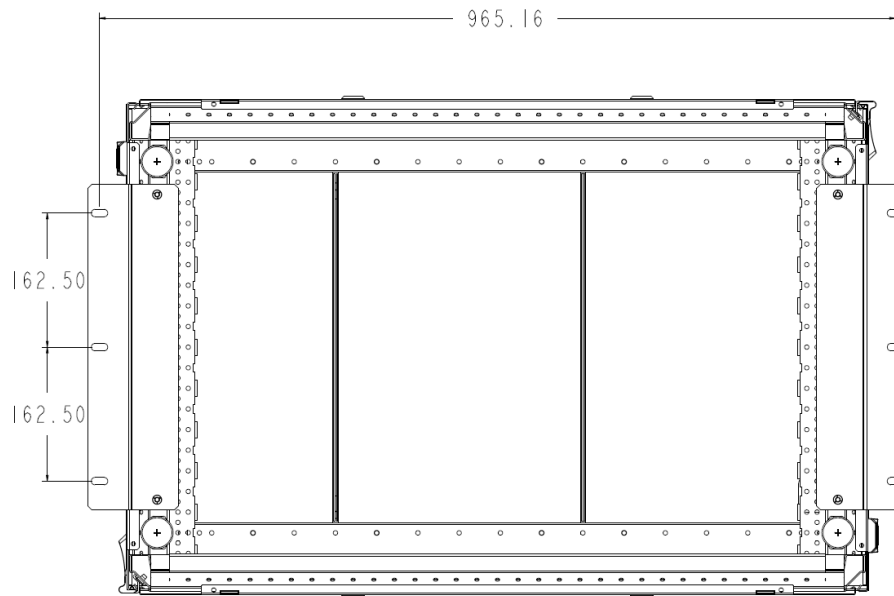

### 4.2 900 MHz eNodeB Cabinet Grounding

During the 900MHz eNodeB Cabinet installation, it is important that the rack ground bus bar is properly connected to the site ground system or master ground bus bar (MGB). Grounding ensures that surge events do not produce ground potential differences that affect signals between the racks.

A #2 AWG wire stub out of the top of the cabinet is provided to connect the 900MHz eNodeB Cabinet to the site ground system. This stub is to be bonded to the site ground system in accordance with the Standards and Guidelines for Communication Sites. All devices within the 900MHz eNodeB Cabinet are grounded to the rack ground bus bar through #6 AWG ground conductors.

**Figure 25: 900 MHz eNodeB Cabinet Grounding**

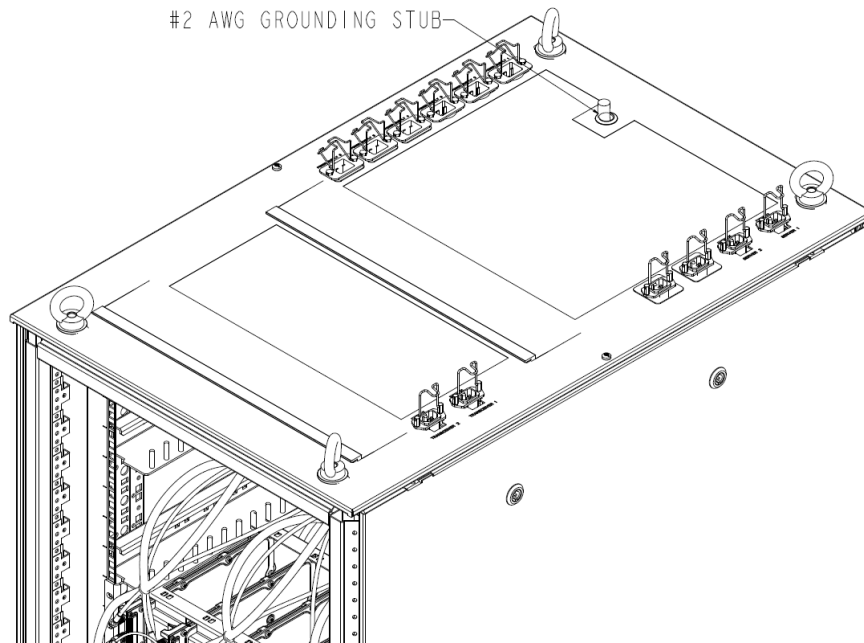

See the *Standards and Guidelines for Communication Sites R56* manual for detailed information on grounding and lightning protection.

#### 4.3

### RF Antenna Connections

The antenna leads should be dropped above the cabinet as per the site plan. Identify and tag all antenna cables designated for connection to the 900 MHz eNodeB Cabinet. Ensure to document this information for future use.



**NOTE:** Proper surge protection should be installed on RF inputs to prevent potential damage to the 900 MHz eNodeB Cabinet. The antenna connectors are type QN. The center connector is gold plated, the outer body is silver plated. It is recommended that mating antenna feed connectors match metal plating correspondingly. The screens of the antenna cables have to be grounded near to the 900 MHz eNodeB Cabinet in accordance with the R56 guidelines and national standards.

Antenna leads are to be fed through brush panel and connected to duplexers.

**Figure 26: Antenna Connection Locations**

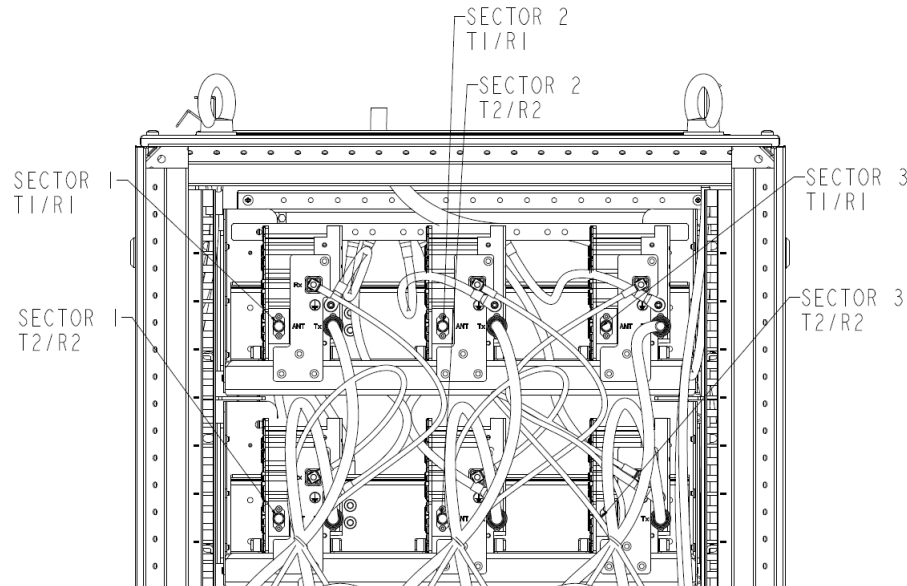

#### 4.4

### Connecting Power to an AC Power Source

For the 900MHz eNodeB Cabinet, the main frame power requires 20 A receptacles, due to the power rating of the AC power supply. Four 6' NEMA 5-15p to IEC C15 cables are provided to connect to server and transceiver power. A separate circuit breaker for each power cable is recommended to ensure that redundant equipment does not simultaneously lose power when a breaker is tripped or opened.

All AC power breakers, wiring and receptacles must comply with the installation guidelines specified in Standards and Guidelines for Communication Sites.



**CAUTION:** Ensure that the AC power source and/or breaker(s) are OFF and all safety precautions and procedures for the safe handling of high energy sources are followed.

#### Procedure:

- 1 Remove the power cords from the loose shipment accessories.
- 2 For each IEC C19 to NEMA 5-20 power cords, insert the C19 connectors of the cables into the IEC C-20 connectors on the junction. Select the connectors depending on the cabinet sector:
  - For one sector cabinets select the connectors labeled “POWER SUPPLY 1”, “POWER SUPPLY 2” and “POWER SUPPLY 3”.
  - For two sector cabinets, make the connections for 1 sector cabinets as well as “POWER SUPPLY 4”.
  - For three sector cabinets, make the connections for 2 sector cabinets as well as “POWER SUPPLY 5”.
- 3 For each IEC C15 to NEMA 5-15 power cords, insert the C15 connectors of the cables into the IEC C14 connectors on the junction panel labeled “TRANSCEIVER 1”, “TRANSCEIVER 2”, “SERVER 1” and “SERVER 2”.
- 4 Place the cable retention clip over the strain relief of the C19 and C15 connectors of the power cords, and squeeze it to clamp on and retain the cable from accidental removal.
- 5 Connect the NEMA 5-20 and NEMA 5-15 plugs into a compatible wall receptacle to apply power.