

CONTENTS

Computer Software Copyrights	3	On/Off/Volume Knob	16
Safety	5	Channel Selector Knob	16
Safety and General Information	5	Push-to-Talk (PTT) Button	16
RF Operational Characteristics	5	Microphone	16
Exposure To Radio Frequency Energy	5	LED Indicator	16
Portable Radio Operation	6	Programmable Buttons	16
and EME Exposure	6	Indicator Tones	18
Antenna Care	6	Audio Indicators for Programmable	
Two-Way Radio Operation	6	Buttons	18
Body-Worn Operation	6	Improved Audio Features	19
Data Operation	6	Low Level Expansion (LLE)	19
Approved Accessories	7	Companding	19
Electromagnetic Interference/		Getting Started	21
Compatibility	7	Battery Information	21
Safety and General	8	Battery Care and Tips	21
Operational Warnings	8	Charging your Battery	22
Operational Cautions	9	Battery Status	22
Intrinsically Safe Radio Information	10	Accessory Information	24
FMRC Approved Equipment	10	Attaching the Battery	24
Repair of FMRC Approved Products	11	Removing the Battery	24
Radio Overview	15	Attaching the Antenna	25
Parts of the Radio	15	Removing the Antenna	25
		Attaching the Side Connector Cover	26
		Turning The Radio On or Off	26
		Adjusting the Radio's Volume	27
		Selecting a Radio Channel	27

Motorola, the stylized M logo are trademarks of Motorola, Inc.
® Reg. U.S. Patent & Trademark Office. All other product or
service names are the property of their respective owners.
© 2001 Motorola, Inc. All rights reserved. Printed in U.S.A.

Motorola, le logo stylisé M sont des marques de commerce de
Motorola, Inc. MD Marque déposée. U.S. Patent & Trademark
Office. Tous les autres noms de produits ou services
appartiennent à leurs propriétaires respectifs.
© 2001 Motorola, Inc. Tous droits réservés. Imprimé aux États-Unis.



68P81093C98-O



EX500

User Guide
Guide de l'utilisateur



Sending a Call	27	Batteries	41
Receiving a Call	27	Chargers	41
Radio Call Information	29	Antennas	42
Receiving a Selective Call	29		
Receiving a Call Alert™ Page	29		
Emergency Alarms	29		
Talkaround	30		
Squelch	30		
Power Level	31		
Scan	33		
Starting or Stopping a Scan Operation . . .	33		
Talkback	33		
Deleting a Nuisance Channel	33		
Adding a Deleted Nuisance Channel back to the Scan List	34		
Scan Channel Discovery Alert	34		
Scan List Member Priority	34		
Warranty	37		
Limited Warranty	37		
Accessories	41		
Carry Cases	41		
Remote Speaker Microphones	41		
Earpieces	41		

COMPUTER SOFTWARE COPYRIGHTS

The Motorola products described in this manual may include copyrighted Motorola computer programs stored in semiconductor memories or other media. Laws in the United States and other countries preserve for Motorola certain exclusive rights for copyrighted computer programs, including, but not limited to, the exclusive right to copy or reproduce in any form the copyrighted computer program. Accordingly, any copyrighted Motorola computer programs contained in the Motorola products described in this manual may not be copied, reproduced, modified, reverse-engineered, or distributed in any manner without the express written permission of Motorola. Furthermore, the purchase of Motorola products shall not be deemed to grant either directly or by implication, estoppel, or otherwise, any license under the copyrights, patents or patent applications of Motorola, except for the normal non-exclusive license to use that

arises by operation of law in the sale of a product.

NOTES

SAFETY

SAFETY AND GENERAL INFORMATION

IMPORTANT INFORMATION ON SAFE AND EFFICIENT OPERATION

READ THIS INFORMATION BEFORE USING YOUR MOTOROLA TWO-WAY RADIO

The information provided in this document supersedes the general safety information contained in user guides published prior to October 2000. For information regarding radio use in a hazardous atmosphere refer to the Factory Mutual (FM) manual supplement included with radio models that offer this capability and/or the intrinsic safety radio information section of this user manual.

RADIO FREQUENCY (RF) OPERATIONAL CHARACTERISTICS

To transmit (talk) you must push the Push-To-Talk button; to receive (listen) you must release the Push-To-Talk button. When the radio is transmitting, it generates radio

frequency (RF) energy; when it is receiving, or when it is off, it does not generate RF energy.

PORTABLE RADIO OPERATION AND EME EXPOSURE

Your Motorola radio is designed to comply with the following national and international standards and guidelines regarding exposure of human beings to radio frequency electromagnetic energy (EME):

- United States Federal Communications Commission, Code of Federal Regulations; 47 CFR part 2 sub-part J
- American National Standards Institute (ANSI) / Institute of Electrical and Electronic Engineers (IEEE) C95. 1-1992
- Institute of Electrical and Electronic Engineers (IEEE) C95.1-1999 Edition
- National Council on Radiation Protection and Measurements (NCRP) of the United States, Report 86, 1986
- International Commission on Non-Ionizing Radiation Protection (ICNIRP) 1998

- Ministry of Health (Canada) Safety Code 6. Limits of Human Exposure to Radio Frequency Electromagnetic Fields in the Frequency Range from 3 kHz to 300 GHz, 1999
- Australian Communications Authority Radiocommunications (Electromagnetic Radiation - Human Exposure) Standard 1999 (applicable to wireless phones only)

To assure optimal radio performance and make sure human exposure to radio frequency electromagnetic energy is within the guidelines set forth in the above standards, always adhere to the following procedures:

Two-way Radio Operation



When using your radio, **hold the radio in a vertical position with the microphone one to two inches (2.5 to 5 centimeters) away from the lips.**

Body-worn Operation

To maintain compliance with FCC RF exposure guidelines, if you wear a radio on your body when transmitting, always place the radio in a **Motorola approved clip, holder, holster, case, or body harness for this product.** Use of non-Motorola-approved accessories may exceed FCC RF exposure guidelines. **If you do not use a Motorola approved body-worn accessory and are not using the radio in the intended use positions along side of the head in the phone mode or in front of the face in the two-way radio mode, then ensure the antenna and radio is kept the following minimum distances from the body when transmitting:**

- Phone or Two-way radio mode: one inch (2.5 centimeters)
- Data operation using any data feature with or without an accessory cable: one inch (2.5 centimeters)

Antenna Care

Use only the supplied or an approved replacement antenna. Unauthorized antennas, modifications, or attachments could

damage the radio and may violate FCC regulations.

DO NOT hold the antenna when the radio is “IN USE”. Holding the antenna affects call quality and may cause the radio to operate at a higher power level than needed.

Approved Accessories

For a list of approved Motorola accessories look in the appendix or accessory section of your radio’s User Guide.

ELECTROMAGNETIC INTERFERENCE/COMPATIBILITY

Note: Nearly every electronic device is susceptible to electromagnetic interference (EMI) if inadequately shielded, designed or otherwise configured for electromagnetic compatibility.

FACILITIES

To avoid electromagnetic interference and/or compatibility conflicts, turn off your radio in any facility where posted notices instruct you to do so. Hospitals or health care facilities may be

using equipment that is sensitive to external RF energy.

AIRCRAFT

When instructed to do so, turn off your radio when on board an aircraft. Any use of a radio must be in accordance with applicable regulations per airline crew instructions.

Medical Devices

- **Pacemakers**

The Health Industry Manufacturers Association recommends that a minimum separation of 6 inches (15 centimeters) be maintained between a handheld wireless radio and a pacemaker. These recommendations are consistent with those of the U.S. Food and Drug Administration.

Persons with pacemakers should:

- ALWAYS keep the radio more than 6 inches (15 centimeters) from their pacemaker when the radio is turned ON.
- not carry the radio in the breast pocket.

- use the ear opposite the pacemaker to minimize the potential for interference.
- turn the radio OFF immediately if you have any reason to suspect that interference is taking place.
- **Hearing Aids**

Some digital wireless radios may interfere with some hearing aids. In the event of such interference, you may want to consult your hearing aid manufacturer to discuss alternatives.

- **Other Medical Devices**

If you use any other personal medical device, consult the manufacturer of your device to determine if it is adequately shielded from RF energy. Your physician may be able to assist you in obtaining this information.

SAFETY AND GENERAL

Use While Driving

Check the laws and regulations on the use of radios in the area where you drive. Always obey them.

When using your radio while driving, please:

- Give full attention to driving and to the road.
- Use hands-free operation, if available.
- Pull off the road and park before making or answering a call if driving conditions so require.

OPERATIONAL WARNINGS



WARNING

FOR VEHICLES WITH AN AIR BAG

Do not place a portable radio in the area over an air bag or in the air bag deployment area. Air bags inflate with great force. If a portable radio is placed in the air bag deployment area and the air bag inflates, the radio may be propelled with great force and cause serious injury to occupants of the vehicle.

POTENTIALLY EXPLOSIVE ATMOSPHERES

Turn off your radio prior to entering any area with a potentially explosive atmosphere, unless it is a radio type especially qualified for use in such areas as "Intrinsically Safe" (for example, Factory Mutual, CSA, UL, or CENELEC). Do

not remove, install, or charge batteries in such areas. Sparks in a potentially explosive atmosphere can cause an explosion or fire resulting in bodily injury or even death.

Note: The areas with potentially explosive atmospheres referred to above include fueling areas such as below decks on boats, fuel or chemical transfer or storage facilities, areas where the air contains chemicals or particles, such as grain, dust or metal powders, and any other area where you would normally be advised to turn off your vehicle engine. Areas with potentially explosive atmospheres are often but not always posted.

BLASTING CAPS AND AREAS

To avoid possible interference with blasting operations, turn off your radio when you are near electrical blasting caps, in a blasting area, or in areas posted: "Turn off two-way radio." Obey all signs and instructions.

OPERATIONAL CAUTIONS



Caution

ANTENNAS

Do not use any portable radio that has a damaged antenna. If a damaged antenna comes into contact with your skin, a minor

burn can result.

BATTERIES

All batteries can cause property damage and/or bodily injury such as burns if a conductive material such as jewelry, keys, or beaded chains touch exposed terminals. The conductive material may complete an electrical circuit (short circuit) and become quite hot. Exercise care in handling any charged battery, particularly when placing it inside a pocket, purse, or other container with metal objects.

INTRINSICALLY SAFE RADIO INFORMATION

FMRC Approved Equipment

Anyone intending to use a radio in a location where hazardous concentrations of flammable material exist (hazardous atmosphere) is advised to become familiar with the subject of intrinsic safety and with the National Electric Code NFPA 70 (National Fire Protection Association) Article 500 (hazardous [classified] locations).

An Approval Guide, issued by Factory Mutual Research Corporation (FMRC), lists manufacturers and the products approved by FMRC for use in such locations. FMRC has also issued a voluntary approval standard for repair service ("Class Number 3605").

FMRC Approval labels are attached to the radio to identify the unit as being FM Approved for specified hazardous atmospheres. This label specifies the hazardous Class/Division/Group along with the part number of the battery that must be used. Depending on the design of the portable unit, this FM label can be found on the back or the bottom of the radio

housing. The FM Approval mark is shown below:



WARNING

WARNINGS

- Do not operate radio communications equipment in a hazardous atmosphere unless it is a type especially qualified for such use (e.g., FMRC Approved). An explosion or fire may result.
- Do not operate an FMRC Approved Product in a hazardous atmosphere if it has been physically damaged (e.g., cracked housing). An explosion or fire may result.
- Do not replace or charge batteries in a hazardous atmosphere. Contact sparking may occur while installing or removing batteries and cause an explosion or fire.



WARNING

WARNINGS

- Do not replace or change accessories in a hazardous atmosphere.

Contact sparking may occur while installing or removing accessories and cause an explosion or fire.

- Do not operate an FMRC Approved Product unit in a hazardous location with the accessory contacts exposed. Keep the connector cover in place when accessories are not used.
- Turn a radio off before removing or installing a battery or accessory.
- Do not disassemble an FMRC Approved Product unit in any way that exposes the internal electrical circuits of the unit.
- Radios must ship from the Motorola manufacturing facility with the hazardous atmosphere capability and FM Approval labeling. Radios will not be “upgraded” to this capability and labeled in the field.
- A modification changes the unit’s hardware from its original design configuration. Modifications can only be made by the original product manufacturer at one of its FMRC-audited manufacturing facilities.



WARNING

WARNINGS

- Failure to use an FMRC Approved Product unit with an FMRC Approved battery or FMRC Approved accessories specifically approved for that product may result in the dangerously unsafe condition of an unapproved radio combination being used in a hazardous location.
- Unauthorized or incorrect modification of an FMRC Approved Product unit will negate the Approval rating of the product.

Repair of FMRC Approved Products

REPAIRS FOR MOTOROLA PRODUCTS WITH FMRC APPROVAL ARE THE RESPONSIBILITY OF THE USER.

You should not repair or relabel any Motorola-manufactured communication equipment bearing the FMRC Approval label (“FMRC Approved Product”) unless you are familiar with the current FMRC Approval standard for repairs and service (“Class Number 3605”). You may want to consider using a repair facility that operates under 3605 repair service approval.



WARNINGS

WARNING

- Incorrect repair or relabeling of any FMRC Approved Product unit could adversely affect the Approval rating of the unit.
- Use of a radio that is not intrinsically safe in a hazardous atmosphere could result in serious injury or death.

FMRC's Approval Standard Class Number 3605 is subject to change at any time without notice to you, so you may want to obtain a current copy of 3605 from FMRC. Per the December 1994 publication of 3605, some key definitions and service requirements are as follows:

Repair

A repair constitutes something done internally to the unit that would bring it back to its original condition—Approved by FMRC. A repair should be done in an FMRC Approved facility. Items not considered as repairs are those in which an action is performed on a unit which does not require the outer casing of the unit to be opened in a manner which exposes the

internal electrical circuits of the unit. You do not have to be an FMRC Approved Repair Facility to perform these actions.

Relabeling

The repair facility shall have a method by which the replacement of FMRC Approval labels are controlled to ensure that any relabeling is limited to units that were originally shipped from the Manufacturer with an FM Approval label in place. FMRC Approval labels shall not be stocked by the repair facility. An FMRC Approval label shall be ordered from the original manufacturer, as needed, to repair a specific unit. Replacement labels may be obtained and applied by the repair facility, provided there is satisfactory evidence that the unit being relabeled was originally an FMRC Approved unit. Verification may include, but is not limited to: a unit with a damaged Approval label, a unit with a defective housing displaying an Approval label, or a customer invoice indicating the serial number of the unit and purchase of an FMRC Approved model.

Do Not Substitute Options or Accessories

The Motorola communications equipment certified by Factory Mutual is tested as a system and consists of the FM Approved portable, FM Approved battery, and FM Approved accessories or options, or both. This FM Approved portable and battery combination must be strictly observed. There must be no substitution of items, even if the substitute has been previously Approved with a different Motorola communications equipment unit. Approved configurations are listed in the FM Approval Guide published by FMRC, or in the product FM Supplement. This FM Supplement is shipped from the manufacturer with the FM Approved radio and battery combination. The Approval Guide, or the Approval Standard Class Number 3605 document for repairs and service, can be ordered directly from Factory Mutual Research Corporation located in Norwood, Massachusetts.

NOTES

RADIO OVERVIEW

PARTS OF THE RADIO

EX500 Model

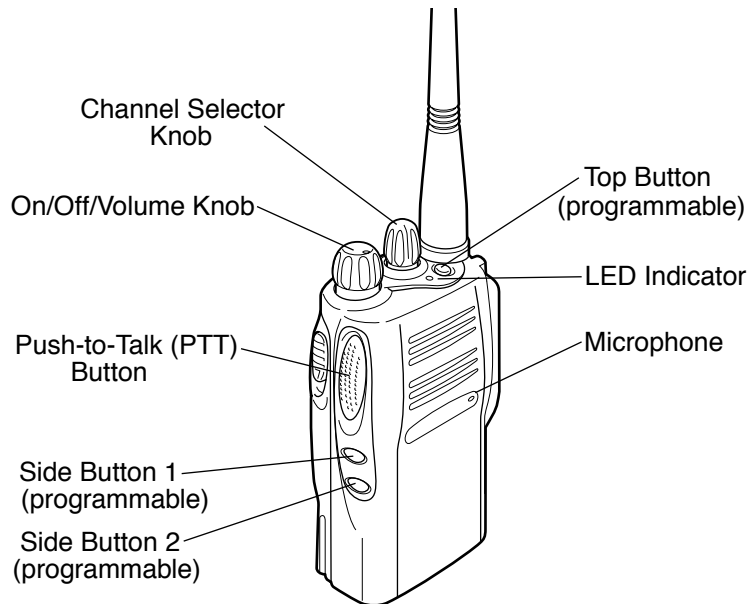

On/Off/Volume Knob

Turns the radio on or off, and adjusts the radio's volume.

Channel Selector Knob

Switches the radio to different channels.

Push-to-Talk (PTT) Button

Press and hold down this button to talk, release it to listen.

Microphone

Speak clearly into the microphone when sending a message.

LED Indicator

Gives battery status, power-up status, radio call information and scan status.

Programmable Buttons

Several of the radio's buttons can be programmed as short-cut buttons for many of the radio's features. Programmable buttons include:

- Top button,
- two side buttons

Each button can access up to two features, depending on the type of button press:

- **short press** - quickly pressing and releasing the programmable buttons, or
- **long press** - pressing and holding the programmable buttons for at least 1 1/2 seconds, or
- **hold down** - pressing and holding down the programmable buttons while checking status or making adjustments.

The table on page 17 summarizes the programmable features available.

Button	Short Press	Long Press	Press and Hold	Page	Button
Emergency*	Initiates an Emergency Alert.	Cancels your radio's Emergency status.	—	29	
Monitor/Permanent Monitor	—	Continually monitors the selected channel.	Monitors the selected channel for any activity.	33	
Volume Set	—	—	Sounds a tone for adjusting the radio's volume level.	27	
Battery Gauge	—	—	Checks the battery's charge status.	22	
Scan/Nuisance Channel Delete	Toggles Scan on and off.	Deletes a nuisance channel while scanning.	—	33	
Tx Power	Toggles your radio's transmit power level between High and Low power.†		—	31	
Repeater/Talkaround	Toggle between using a repeater or transmitting directly to another radio.†		—	30	
Squelch	Toggles your radio's squelch level between tight/normal squelch.†		—	30	

* If Emergency function is required, it can ONLY be programmed to the Top Button.

† Depending on how your radio has been programmed by your dealer, these functions are activated EITHER through short press OR long press, but not both.

INDICATOR TONES

High pitched tone Low pitched tone



Self Test Pass Tone



Self Test Fail Tone



Positive Indicator Tone



Negative Indicator Tone

AUDIO INDICATORS FOR PROGRAMMABLE BUTTONS

Some programmable keys function as toggles (alternating between two different choices). These keys use audio indicators to indicate the change.

Programmable Buttons	Positive Indicator Tone	Negative Indicator Tone
Scan	Starts Scan operation	Stops Scan operation
Tx Power	Transmits at low power	Transmits at high power
Squelch	Operates in tight squelch	Operates in normal squelch
Repeater/ Talkaround	DOES NOT use the repeater	Uses the repeater

IMPROVED AUDIO FEATURES

Low Level Expansion (LLE)

The LLE feature of your radio improves voice quality by reducing unwanted background noise when receiving a message. It is compatible with most major types of audio processing systems available today.

Comanding

Comanding is a feature that allows further improvement of voice quality. It compresses your voice at transmission, and expands it when receiving while simultaneously reducing extraneous noise. However, to enjoy this benefit, **ALL** transmitting and receiving radios must have this feature activated.

NOTE: Contact your dealer for your radio's current comanding settings or to change the settings.

NOTES

GETTING STARTED

BATTERY INFORMATION

Battery Care and Tips

This product is powered by a rechargeable battery.

The following battery tips will help you obtain the highest performance and longest cycle life from your Motorola rechargeable battery.

- Batteries are shipped uncharged from the factory. Always charge a new battery 14 - 16 hours before initial use, regardless of the status indicated by the charger.
- Charging in non-Motorola equipment may lead to battery damage and void the battery warranty.
- When charging a battery that is attached to the radio, turn the radio off to ensure a full charge.
- The battery should be at about 77°F (25°C) (room temperature) whenever possible. Charging a cold battery, (below 50°F [10°C]) may result in leakage of electrolyte and ultimately, in failure of the battery.
- Charging a hot battery (above 95°F [35°C]) results in reduced discharge capacity, affecting the performance of the radio. Motorola rapid-rate battery chargers contain a temperature-sensing circuit to ensure that the battery is charged within these temperature limits.
- New batteries can be stored up to two years without significant cycle loss. Store new/unused batteries in a cool dry area.
- Batteries which have been in storage should be charged overnight.
- Do not return fully charged batteries to the charger for an “extra boost”. This action will **significantly** reduce cycle life.
- Do not leave your radio and battery in the charger when not charging. Continuous charging will shorten battery life. (Do not use your charger

as a radio stand.)

- For optimum battery life and operation use only Motorola brand chargers. They were designed to operate as an integrated energy system.

Charging your Battery

When the battery level is very low, you need to recharge the battery before you can continue to use your radio.

1. Place the radio with the battery attached or the battery alone in the charger.
2. The charger's LED would indicate the charging progress.

NOTE: Because new batteries or batteries that have not been used for several months could prematurely indicate full charge (solid green LED), charge the batteries for 14 to 16 hours prior to initial use to achieve optimal performance.

LED color	Status
Single flash of Green	Successful charger power-up.
Flashing Red*	Battery is unchargeable.
Flashing Yellow	Charger is getting ready to charge.
Red	Battery is charging.
Flashing Green†	Battery is 90% charged.
Green	Battery is fully charged.

* Remove the battery from charger and use a pencil eraser to clean the four metal contacts on the bottom of the battery. Place the battery back into the charger. If the LED indicator continues to flash red, replace the battery.

† A standard battery may require one hour to charge to 90% capacity.

Battery Status

You can check battery charge status by holding down the preprogrammed **Battery Gauge** button (see page 17). The charge status is

shown is shown by the color of the radio's LED Indicator.

Battery Level	LED Indicator
High	Green
Satisfactory	Yellow
Low	Flashing Red
Very Low	None

NOTE: If the Battery Gauge indicator does NOT appear, this indicates that the battery may not be a genuine Motorola product.

ACCESSORY INFORMATION

Attaching the Battery

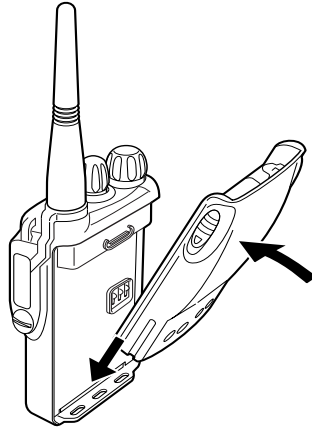

- 1 Fit the extensions at the bottom of the battery into the slots at the bottom of the radio.
- 2 Press the top part of the battery towards the radio until a click is heard.
Note: It is important to make sure that both battery latches are secured.

Removing the Battery

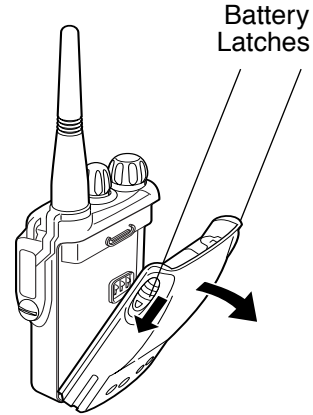

- 1 Turn off the radio, if it is turned on.
- 2 Slide the battery latches, on both sides of the battery, downwards.
- 3 Pull the top part of the battery away from the radio.

Attaching the Antenna

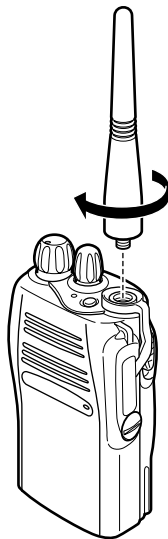

- 1 Align the threaded end of the antenna with the radio's antenna connector.
- 2 Turn the antenna clockwise to attach it.

Removing the Antenna

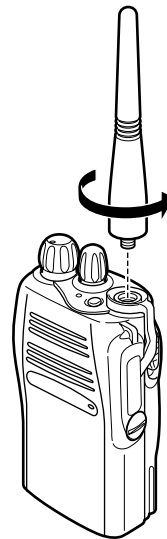

Turn the antenna counterclockwise to remove it.

Attaching the Side Connector Cover

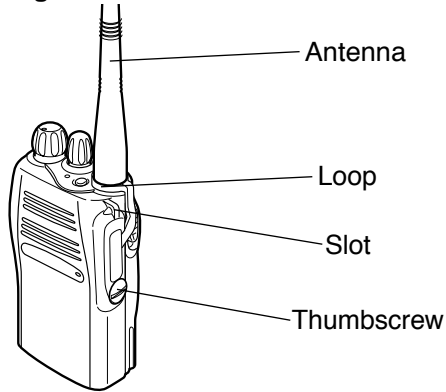

- 1 Place the loop (attached to the side connector cover) over the antenna; then slide it downward until it touches the top of the radio.
- 2 Insert the tab on the top of the cover into the slot above the connector.
- 3 Position the cover over the connector and align the thumbscrew with the threaded hole in the radio.
- 4 Tighten the thumbscrew to hold the cover in place. **Do not overtighten the thumbscrew.**

TURNING THE RADIO ON OR OFF

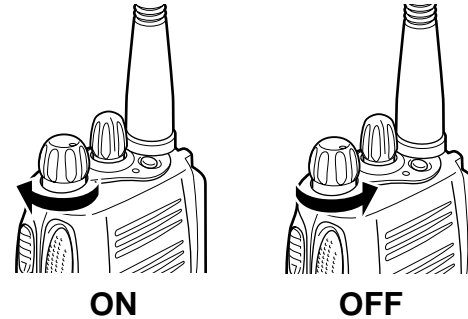

- 1 Turn the **On/Off/Volume** (see page 15) knob clockwise to turn on the radio. You will hear the Self Test Pass Tone and see a green LED if the radio powers up successfully. If the radio fails to power up, you will hear the Self Test Fail Tone.
- 2 Turn the **On/Off/Volume** knob (see page 15) counter-clockwise, until a click is heard, to turn off the radio.

ADJUSTING THE RADIO'S VOLUME

- 1 Press and hold the **Volume Set** button (see page 17); you will hear a continuous tone.
- 2 Turn the **On/Off/Volume** knob (see page 16) and adjust the volume level.
- 3 Release the **Volume Set** button (see page 17).

SELECTING A RADIO CHANNEL

Your radio offers sixteen (16) channels for easy access to required conventional channels. Some channels on your radio may not be programmed. Check with your dealer for more information.

To select a channel:

Turn the **Channel Selector** knob (see page 15) clockwise or counter-clockwise until you reach the desired channel.

SENDING A CALL

- 1 Turn your radio on.
- 2 Use the **Channel Selector** knob (see page 15) to select to the desired channel.
- 3 Press the **PTT** button (see page 15), and speak clearly with your mouth about 2.5 to 5 cm (one to two inches) away from the microphone.
- 4 Release the **PTT** button (see page 15) when you finish speaking.

RECEIVING A CALL

- 1 Turn your radio on.
- 2 Adjust the radio's volume.
- 3 Switch to the desired channel.
- 4 If at any time a call comes through, you will hear the call at the volume level you have set.

NOTES

RADIO CALL INFORMATION

RECEIVING A SELECTIVE CALL

Selective Call allows a radio user to communicate with a single unit without involving other units in conversation.

When you receive a selective call:

- You will hear two alert tones.
- The LED Indicator will light yellow.

To answer the call, press the **PTT** button.

RECEIVING A CALL ALERT™ PAGE

When your radio receives a Call Alert page, it sounds four alert tones continuously until you respond.

Press the **PTT** button to answer the Call Alert page, or press any other key to cancel it.

Note: Your radio will not receive any Selective Calls until you clear the page.

EMERGENCY ALARMS

If programmed by your dealer, the orange Top button can send one of the following emergency alarms described below:

- MDC Emergency Alarm (only if the signaling system you are on is MDC), and
- Emergency Siren

Note: The **MDC Emergency Alarm** feature gives you a one-button quick access to call a particular radio or center (pre-defined by your dealer) in emergency situations. When activated, the radio goes into an Emergency state, which can be programmed to

- continually give visual and audio feedback,
- give no audio feedback, but with visual feedback, or
- give no audio/visual feedback, but the radio can receive and transmit.

The **Emergency Siren** will cause the radio to sound a repetitive tone at the maximum volume.

- 1 Press and release the **Emergency** button (see page 17) to initiate an Emergency Alarm.
- 2 Press and hold the **Emergency** button (see page 17) to cancel the Emergency Alarm.
- 3 Press and release the **Emergency** button (see page 17) to restart the Emergency sequence.

TALKAROUND

In your communications network, you may be using a repeater to cover a larger area than what is possible with your radio. However, you can communicate with another radio within your radio's range without going through the repeater by using the *Talkaround* feature. This is especially useful when the repeater is down

Press the programmed **Repeater/Talkaround** button to toggle between the options of making or not making a call through the repeater. A positive indicator tone indicates that the radio is in talkaround mode, while a negative indicator tone indicates that the radio is in repeater mode.

SQUELCH

If a particular channel receives many unwanted calls coming from radios that do not belong to your communications group and are some distance away, or the "background noise" is excessive, you can try to filter these transmissions out by tightening the channel's squelch. However, tightening squelch could cause calls from members of your communications group that are farther away to be filtered out as well.

To set the squelch level:

Press the programmed **Squelch** button to toggle between the options of having normal squelch or tightening the squelch of your radio. A positive indicator tone indicates that the radio is operating in tight squelch, while a negative indicator tone indicates that the radio is operating in normal squelch.

POWER LEVEL

You can transmit your calls at different transmit power levels. A higher level means you can reach a radio that is farther away. Lower power level conserves battery power. You are advised to transmit as frequently as possible on low power, and use high power only when needed.

Press the programmed **Tx Power** button to toggle between the options for High or Low power transmit level. A positive indicator tone indicates that the radio is operating in low power mode, while a negative indicator tone indicates that the radio is operating in high power mode.

NOTES

SCAN

You can monitor several channels in order to receive any call that is transmitted on any of these channels. Sixteen different channels can be programmed into a scan list. Each channel can share the same scan list or have different scan lists assigned to them.

Once the radio's scan operation is activated and the radio detects a call coming through a channel in its scan list, it switches to that channel for you to receive the call.

STARTING OR STOPPING A SCAN OPERATION

The LED Indicator will blink (green) during a scan operation. It will stop blinking when the radio switches to a channel.

- 1 Press the **Scan** button (see page 17) to start a scan operation.
- 2 Press the **Scan** button again to stop the scan operation.

TALKBACK

If the programmable Talkback option is set, you can respond to any calls received during the scan operation by pressing the **PTT** button before the programmed hang-time ends. Check with your dealer for details.

DELETING A NUISANCE CHANNEL

If a channel continually generates unwanted calls/noise, you can temporarily remove it from the scan list by performing a *Nuisance Channel Delete* operation.

- 1 While the radio is on the Nuisance Channel, press and hold the **Scan** button (see page 17) until you hear a tone.
- 2 Release the **Scan** button.

Note: You cannot perform a *Nuisance Channel Delete* on a priority channel or if there is only one remaining channel in the scan list.

ADDING A DELETED NUISANCE CHANNEL BACK TO THE SCAN LIST

- 1 Press the **Scan** button (see page 17) to stop the scan operation.
- 2 Press the **Scan** button again to re-start the scan operation.

SCAN CHANNEL DISCOVERY ALERT

Sometimes you need to know which channel the radio has switched to during a scan operation. The Scan Channel Discovery Alert gives you this information.

After you have stopped a scan operation, this feature gives you audio feedback when you select the last channel that was switched to by the scan operation.

To do this:

- 1 Stop the scan operation.
- 2 Turn the **Channel Selector** knob (see page 15) to change the channels.

- 3 When you reach the last channel the scan operation switched to, the radio sounds an alert tone.

SCAN LIST MEMBER PRIORITY

A channel in your scan list may be prioritized (check with your dealer for details). In such a case, the radio will check that prioritized channel more frequently than the other non-prioritized channels.

Assuming a scan list with 6 channels, if all your channels are non-prioritized, the normal scan operation would check for activity in the following sequence:

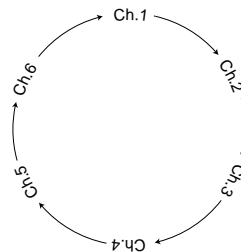

If Channel 2 is prioritized, the scan operation would change to

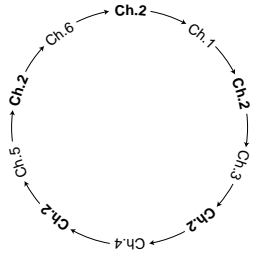

Note: Even though your radio has switched to a non-priority channel, your radio will still check for activity on the priority channel. If some activity is detected there, the radio will switch to that priority channel.

NOTES

WARRANTY

LIMITED WARRANTY MOTOROLA COMMUNICATION PRODUCTS

I. WHAT THIS WARRANTY COVERS AND FOR HOW LONG:

MOTOROLA INC. (“MOTOROLA”) warrants the MOTOROLA manufactured Communication Products listed below (“Product”) against defects in material and workmanship under normal use and service for a period of time from the date of purchase as scheduled below:

EX500 Units	Two (2) Years
Product Accessories	One (1) Year

Motorola, at its option, will at no charge either repair the Product (with new or reconditioned parts), replace it (with a new or reconditioned Product), or refund the purchase price of the Product during the warranty period provided it is returned in accordance with the terms of this warranty. Replaced parts or boards are warranted

for the balance of the original applicable warranty period. All replaced parts of Product shall become the property of MOTOROLA.

This express limited warranty is extended by MOTOROLA to the original end user purchaser only and is not assignable or transferable to any other party. This is the complete warranty for the Product manufactured by MOTOROLA.

MOTOROLA assumes no obligations or liability for additions or modifications to this warranty unless made in writing and signed by an officer of MOTOROLA. Unless made in a separate agreement between MOTOROLA and the original end user purchaser, MOTOROLA does not warrant the installation, maintenance or service of the Product.

MOTOROLA cannot be responsible in any way for any ancillary equipment not furnished by MOTOROLA which is attached to or used in connection with the Product, or for operation of the Product with any ancillary equipment, and all such equipment is expressly excluded from this warranty. Because each system which may use the Product is unique, MOTOROLA disclaims liability for range, coverage, or operation of the system as a whole under this warranty.

II. GENERAL PROVISIONS:

This warranty sets forth the full extent of MOTOROLA'S responsibilities regarding the Product. Repair, replacement or refund of the purchase price, at MOTOROLA's option, is the exclusive remedy. THIS WARRANTY IS GIVEN IN LIEU OF ALL OTHER EXPRESS WARRANTIES. IMPLIED WARRANTIES, INCLUDING WITHOUT LIMITATION, IMPLIED WARRANTIES OF MERCHANTABILITY AND FITNESS FOR A PARTICULAR PURPOSE, ARE LIMITED TO THE DURATION OF THIS LIMITED WARRANTY. IN NO EVENT SHALL MOTOROLA BE LIABLE FOR DAMAGES IN EXCESS OF THE PURCHASE PRICE OF THE PRODUCT, FOR ANY LOSS OF USE, LOSS OF TIME, INCONVENIENCE, COMMERCIAL LOSS, LOST PROFITS OR SAVINGS OR OTHER INCIDENTAL, SPECIAL OR CONSEQUENTIAL DAMAGES ARISING OUT OF THE USE OR INABILITY TO USE SUCH PRODUCT, TO THE FULL EXTENT SUCH MAY BE DISCLAIMED BY LAW.

III. STATE LAW RIGHTS:

SOME STATES DO NOT ALLOW THE EXCLUSION OR LIMITATION OF INCIDENTAL

OR CONSEQUENTIAL DAMAGES OR LIMITATION ON HOW LONG AN IMPLIED WARRANTY LASTS, SO THE ABOVE LIMITATION OR EXCLUSIONS MAY NOT APPLY.

This warranty gives specific legal rights, and there may be other rights which may vary from state to state.

IV. HOW TO GET WARRANTY SERVICE:

You must provide proof of purchase (bearing the date of purchase and Product item serial number) in order to receive warranty service and, also, deliver or send the Product item, transportation and insurance prepaid, to an authorized warranty service location. Warranty service will be provided by Motorola through one of its authorized warranty service locations. If you first contact the company which sold you the Product (e.g., dealer or communication service provider), it can facilitate your obtaining warranty service. You can also call Motorola at 1-800-927-2744 US/Canada.

V. WHAT THIS WARRANTY DOES NOT COVER:

- A) Defects or damage resulting from use of the Product in other than its normal and customary manner.
- B) Defects or damage from misuse, accident, water, or neglect.
- C) Defects or damage from improper testing, operation, maintenance, installation, alteration, modification, or adjustment.
- D) Breakage or damage to antennas unless caused directly by defects in material workmanship.
- E) A Product subjected to unauthorized Product modifications, disassemblies or repairs (including, without limitation, the addition to the Product of non-Motorola supplied equipment) which adversely affect performance of the Product or interfere with Motorola's normal warranty inspection and testing of the Product to verify any warranty claim.
- F) Product which has had the serial number removed or made illegible.
- G) Rechargeable batteries if:
 - 1) any of the seals on the battery enclosure of cells are broken or show evidence of tampering.
 - 2) the damage or defect is caused by charging or using the battery in equipment or service other than the Product for which it is specified.
- H) Freight costs to the repair depot.
- I) A Product which, due to illegal or unauthorized alteration of the software/firmware in the Product, does not function in accordance with MOTOROLA's published specifications or the FCC type acceptance labeling in effect for the Product at the time the Product was initially distributed from MOTOROLA.
- J) Scratches or other cosmetic damage to Product surfaces that does not affect the operation of the Product.
- K) Normal and customary wear and tear.

VI. PATENT AND SOFTWARE PROVISIONS:

MOTOROLA will defend, at its own expense, any suit brought against the end user purchaser to the extent that it is based on a claim that the Product or parts infringe a United States patent, and MOTOROLA will pay those costs and damages finally awarded against the end user purchaser in any such suit which are attributable to any such claim, but such defense and payments are conditioned on the following:

- A) that MOTOROLA will be notified promptly in writing by such purchaser of any notice of such claim;
- B) that MOTOROLA will have sole control of the defense of such suit and all negotiations for its settlement or compromise; and
- C) should the Product or parts become, or in MOTOROLA's opinion be likely to become, the subject of a claim of infringement of a United States patent, that such purchaser will permit MOTOROLA, at its option and expense, either to procure for such purchaser the right to continue using the Product or parts or to replace or modify the same so that it becomes non-infringing or to grant such purchaser a credit for the Product or parts as depreciated and accept its return. The depreciation will be an equal amount per year over the lifetime of the Product or parts as established by MOTOROLA.

MOTOROLA will have no liability with respect to any claim of patent infringement which is based upon the combination of the Product or parts furnished hereunder with software, apparatus or devices not furnished by MOTOROLA, nor will MOTOROLA have any liability for the use of ancillary equipment or software not furnished by MOTOROLA which is attached to or used in

connection with the Product. The foregoing states the entire liability of MOTOROLA with respect to infringement of patents by the Product or any parts thereof.

Laws in the United States and other countries preserve for MOTOROLA certain exclusive rights for copyrighted MOTOROLA software such as the exclusive rights to reproduce in copies and distribute copies of such Motorola software. MOTOROLA software may be used in only the Product in which the software was originally embodied and such software in such Product may not be replaced, copied, distributed, modified in any way, or used to produce any derivative thereof. No other use including, without limitation, alteration, modification, reproduction, distribution, or reverse engineering of such MOTOROLA software or exercise of rights in such MOTOROLA software is permitted. No license is granted by implication, estoppel or otherwise under MOTOROLA patent rights or copyrights.

VII. GOVERNING LAW:

This Warranty is governed by the laws of the State of Illinois, USA.

ACCESSORIES

Motorola offers a number of accessories to enhance the productivity of your two-way radio. Many of the available accessories are listed below. Your authorized Motorola dealer will also have a complete list of accessories. Additional Accessories will be available for this product in the near future.

CARRY CASES

HLN9985	Waterproof Bag
JMZN4020	Radio Handstrap
JMZN4023	Plastic Carry Holder with Swivel Belt Clip
PMLN4421	Soft Leather Case with Fixed Swivel Clip

REMOTE SPEAKER MICROPHONES

JMMN4073	Remote Speaker Microphone
----------	---------------------------

EARPIECES

JMMN4062	2 Wire Surveillance Earpiece
----------	------------------------------

BATTERIES

JMNN4023	1000 mAH Li-Ion High Capacity Battery
JMNN4024	1320 mAH Li-Ion Ultra High Capacity Battery

CHARGERS

AAHTN3000	120V Single-Unit Rapid Charger, US Plug
AAHTN3003	120V Multi-Unit Rapid Charger, US Plug

Note: You must use the "C" version multi-charger or newer to be compatible with the EX500.

ANTENNAS

PMAD4012	VHF 136-155 MHz 9cm, Stubby
PMAD4013	VHF 155-174 MHz 9cm, Stubby
PMAD4014	VHF 136-155 MHz 14cm, Standard
PMAD4015	VHF 155-174 MHz 14cm, Standard
PMAD4023	VHF 150-161 MHz, 14cm
PMAD4025	VHF 150-161 MHz, 9cm
PMAE4002	403-433 MHz Stubby Antenna
PMAE4003	433-470 MHz Stubby Antenna
NAE6483	403-512 MHz Whip Antenna
PMAE4006	UHF 470-510 MHz, 9cm, Helical
PMAE4007	UHF 490-512 MHz, 9cm
PMAE4008	UHF 470-512 MHz, Whip

EX500 Quick Reference Card

Adding a Deleted Nuisance Channel back to the Scan List

1. Press the preprogrammed **Scan** button to stop the scan operation.
2. Press the preprogrammed **Scan** button again to re-start the scan operation.

Programmable Buttons' Audio Indicators

Programmable Buttons	Positive Indicator Tone	Negative Indicator Tone
Scan	Starts Scan operation	Stops Scan operation
Tx Power	Transmits at low power	Transmits at high power
Squelch	Operates in tight squelch	Operates in normal squelch
Repeater/ Talkaround	Radio DOES NOT use the repeater	Radio uses the repeater

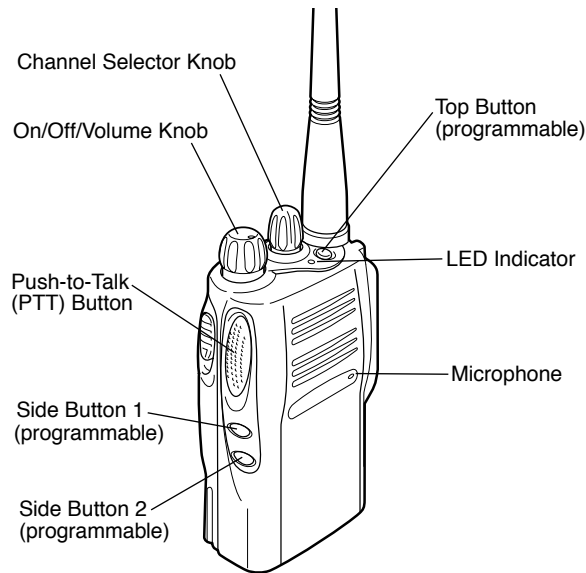

Button	Function	Short Press	Long Press	Hold Down	Page

Turning On the Radio

- Turn **On/Off/Volume** knob clockwise. Self Test Pass Tone will sound and green LED will light up if radio powers up successfully. If radio fails power up, the Self Test Fail Tone will sound.

Turning Off the Radio

- Turn **On/Off/Volume** knob counter-clockwise, until click is heard.

Adjusting the Radio's Volume

1. Press and hold **Volume Set** button until continuous tone is sounded.
2. Turn **On/Off/Volume** knob to adjust volume level.
3. Release **Volume Set** button when desired level is achieved.

Selecting a Radio Channel

- Turn **Channel Selector** knob clockwise or counter-clockwise to reach desired channel.

Sending a Call

1. Turn on radio.
2. Use **Channel Selector** knob to select the desired channel.
3. Press **PTT** button, and speak clearly with mouth about 2.5 to 5 cm (one to two inches) away from microphone.
4. Release **PTT** button when call is completed.

Receiving a Call

1. Turn radio on.
2. Adjust volume level.
3. Switch to desired channel.
4. If at any time a call comes through, it will be heard at the volume level set.

Emergency Alarm

1. Press programmed **Emergency** button to initiate *Emergency Alarm/Siren*.
2. Press and hold **Emergency** button to cancel *Emergency Alarm/Siren*.
3. Press and release **Emergency** button to restart Emergency sequence.

Starting or Stopping a Scan Operation

The LED Indicator will blink (green) during a scan operation. It will stop blinking when the radio switches to a channel.

1. Press the preprogrammed **Scan** button to start a scan operation.
2. Press the preprogrammed **Scan** button again to stop the scan operation.

Deleting a Nuisance Channel

1. While radio is on a Nuisance Channel, press and hold the preprogrammed **Scan** button until a tone is sounded.
2. Release the preprogrammed **Scan** button.