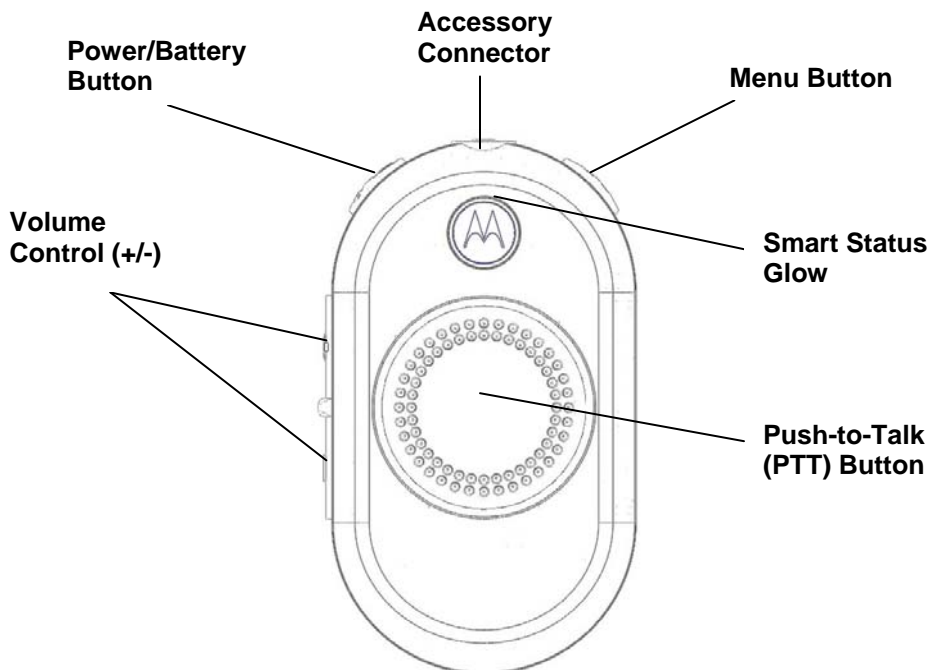

# QUICK REFERENCE CLP SERIES™ PORTABLE RADIO

**ENGLISH**

## Congratulations on your new radio!

Your radio is ready to use after a fully-charged battery has been installed and it is connected to an appropriate audio accessory. Please refer to [www.motorola.com](http://www.motorola.com) for information on approved accessories.

CLP Series professional two-way radios operate on radio frequencies that are regulated by the Federal Communications Commission (FCC). In order to transmit on these frequencies, you are required to have a license issued by the FCC.

<http://www.fcc.gov>

This device complies with Part 15 of the FCC Rules. Operation is subject to the condition that this device does not cause harmful interference.

## GETTING STARTED

### 1. INSTALL THE BATTERY

- Push up the latch at the bottom of the battery door and lift the battery door off the radio.
- Align the battery contacts with tabs in the battery compartment. Insert the contact side of the battery first, then press the battery down to secure in place.
- Put the battery door back on the radio. Push down the latch to lock.

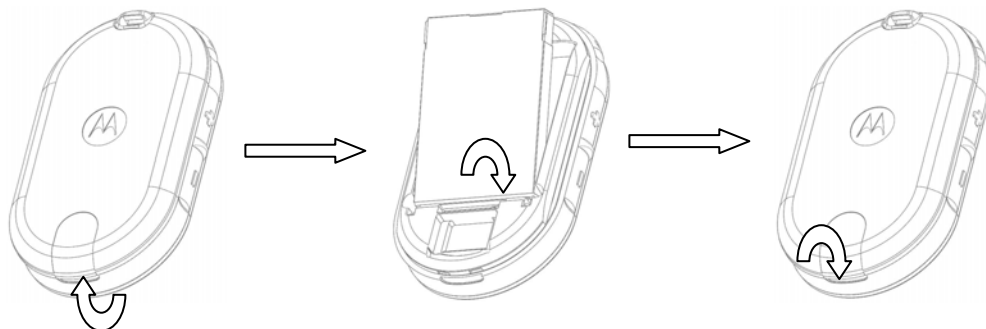

### 2. CHARGE THE BATTERY

Connect the power supply to the drop-in charging tray or multi-unit charger and insert the radio into the tray. The light on the charger is red when the radio is charging. It turns to green once the radio is fully charged.

### 3. CONNECT AN AUDIO ACCESSORY

Connect a wired audio accessory or pair with a wireless accessory (select models only).

### 4. TURN THE RADIO ON

Press and hold the Power/Battery button until you hear a short tone and the Smart Status Glow lights up. (To turn off, press and hold the button until you hear a short tone.)

### 5. CHECK BATTERY STATUS

When powered on, short press and release the Power/Battery button, the Smart Status Glow gives you the battery status:

Green – high level

Yellow – medium level

Red – low level

Red blink – critical

After the Smart Status Glow indicates the BATTERY STATUS, it will return to the current channel color.

## TRANSMITTING AND RECEIVING

1. Turn radio on and set volume level by pressing volume control. A total of 16 volume levels are available from 1 to 16.

2. To talk, press and hold the PTT button on the front of the radio. Speak clearly into the microphone on the audio accessory. When finished talking, release the PTT to listen.

3. To receive, listen through the earpiece at the volume level you have set. Press the PTT to respond.

NOTE: CLP Series radios always require the use of an audio accessory with microphone and speaker.

## OPERATION WITH DEFAULT MENU SETTING:

Menu Item 1: Channel

Menu Item 2: Monitor

Menu Item 3: Scan

Menu Item 4: Call Tone (OFF is default)

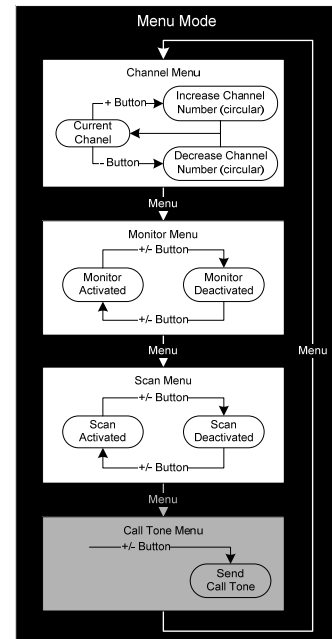

NOTE: For single channel models, only Monitor is available from Menu list. To activate, press and hold the Menu Button; to deactivate, press and hold the Menu Button again.

For further information, refer to your specific product User Guide.

For product-related questions, please call: 1-800-448-6686 or visit [www.motorola.com](http://www.motorola.com)

## ATTENTION

Before using this product, read the RF energy awareness information and operating instructions contained in the Safety and RF Energy Exposure Booklet enclosed with your radio package.

MOTOROLA, the Stylized M Logo, are registered in the U.S. Patent and Trademark Office. All other product or service names are the property of their respective owners.

Motorola, Inc. 2009. All rights reserved.

Printed in Malaysia.



6801200047