



## TALKABOUT® TWO-WAY RADIO T4XX SERIES



MN001126A01-AB

MOTOROLA, MOTO, MOTOROLA SOLUTIONS and the Stylized M logo are trademarks or registered trademarks of Motorola Trademark Holdings, LLC and are used under license. All other trademarks are the property of their respective owners.  
© 2015 Motorola Solutions, Inc. All rights reserved.  
Printed in China

### For More Information

For further information, you may call Motorola Solutions at 1-800-448-6686 (Canada and U.S.), or visit us on the Internet at [www.motorolasolutions.com/talkabout](http://www.motorolasolutions.com/talkabout).

### Safety and General Information

### RF Exposure and Product Safety Instructions for Portable Two-Way Radios General Populated and Uncontrolled Environments.

#### ATTENTION:

Before using this radio, refer to the important operating instructions for safe usage and RF energy awareness and control for compliance with applicable Standards and Regulations.

#### Compliance with RF Exposure Standards

Your Motorola Two-Way radio complies with the following RF energy exposure standard and guidelines:

- United States Federal Communications Commission, Code of Federal Regulations; 47 CFR et seq. & FCC.
- Institute of Electrical and Electronic Engineers (IEEE) C95.1.
- International Commission on Non-Ionizing Radiation Protection (ICNIRP).
- Ministry of Health (Canada) Safety Code 6 & Industry Canada RSS-102.
- Australian Communications Authority Radiocommunications Standard et seq.

#### Transmit and Receive Procedure

Your two-way radio contains a transmitter and a receiver. To control your exposure and ensure compliance with the general population/uncontrolled environment exposure limits, always adhere to the following procedure:

- Transmit no more than 50% of the time.
- To receive calls, release the PTT button.
- To transmit (talk), press the Push-to-Talk (PTT) button in front of the face.
- Hold the radio in a vertical position with the microphone (and other parts of the radio including the antenna) at least one inch (2.5 centimeters) away from the nose or lips. Keeping the radio at a proper distance is important to ensure compliance.

**Note:** RF exposure decreases with increasing distance from the antenna.

- Body Worn Operation. When worn on the body, always place the radio in a Motorola-approved clip, holder, holster, case or body harness for this product.

Please refer to the following websites for more information on what RF energy exposure is and how to control your exposure to assure compliance with established RF exposure limits:

- <http://www.fcc.gov/oet/ef/safety/rf-faqs.html>
- [www.who.int/en/](http://www.who.int/en/)
- <http://responsibility.motorolasolutions.com/index.php/downloads/dow07-rfexposureassessmentstand/>

#### Two-way Radio Operation

- Use only Motorola-approved supplied or replacement antennas, batteries, and audio accessories. Use of non-Motorola-approved antennas, batteries, and wired or wireless accessories may exceed the applicable RF exposure guidelines (IEEE, ICNIRP or FCC).
- For a list of Motorola-approved accessories for your radio model, visit the following website: <http://www.motorolasolutions.com/TalkaboutAccessories>.

### Electromagnetic Interference/Compatibility

**Note:** Nearly every electronic device is susceptible to electromagnetic interference (EMI) if inadequately shielded, designed or otherwise configured for electromagnetic compatibility.

This device complies with part 15 of the FCC Rules. Operation is subject to the following two conditions:

1. This device may not cause harmful interference, and
2. This device must accept any interference received, including interference that may cause undesired operation.

This device complies with Industry Canada licence-exempt RSS standard(s). Operation is subject to the following two conditions:

1. This device may not cause interference, and
2. This device must accept any interference received, including interference that may cause undesired operation of the device.

#### Facilities

To avoid electromagnetic interference and/or compatibility conflicts, turn off your radio in any facility where posted notices instruct you to do so. Hospitals or health care facilities may be using equipment that is sensitive to external RF energy.

#### Aircraft

When instructed to do so, turn off your radio when onboard an aircraft. Any use of a radio must be in accordance with applicable regulations per airline crew instructions.

#### Medical Devices – Pacemakers, Defibrillators or other Implanted Medical Devices

Persons with pacemakers, implantable cardioverter-defibrillators (ICDs) or other active implantable medical devices (AIMD) should:

- Consult with their physicians regarding the potential risk of interference from radio frequency transmitters, such as portable radios (poorly shielded medical devices may be more susceptible to interference).
- Turn the radio OFF immediately if there is any reason to suspect that interference is taking place.
- Do not carry the radio in a chest pocket or near the implantation site, and carry or use the radio on the opposite side of their body from the implantable device to minimize the potential for interference.

#### Hearing Aids

Some digital wireless radios may interfere with some hearing aids. In the event of such interference, you may want to consult your hearing aid manufacturer to discuss alternatives.

#### Other Medical Devices

If you use any other personal medical device, consult the manufacturer of your device to determine if it is adequately shielded from RF energy. Your physician may be able to assist you in obtaining this information.

#### Use of Communication Devices While Driving

Always check the laws and regulations on the use of radios in the areas where you drive.

- Give full attention to driving and to the road.
- Use hands-free operation, if available.
- Pull off the road and park before making or answering a call, if driving conditions or regulations so require.

#### For Vehicle With Air Bags

Refer to the vehicle manual prior to installation of electronic equipment to avoid interference with air bag wiring. Do not place a portable radio in the area over an air bag or in the air bag deployment area. Air bags inflate with great force. If a portable radio is placed in the air bag deployment area and the air bag inflates, the radio may be propelled with great force and cause serious injury to occupants of the vehicle.

#### Potentially Explosive Atmosphere

Turn off your radio prior to entering any area with a potentially explosive atmosphere. Only radio types that are especially qualified should be used in such areas as "Intrinsically Safe". Do not remove, install or charge batteries in such areas. Sparks in a potentially explosive atmosphere can cause an explosion or fire resulting in bodily injury or even death.

**Note:** The areas with potentially explosive atmosphere referred to above include fueling areas such as below decks on boats, fuel or chemical transfer or storage facilities, areas where the air contains chemicals or particles (such as grain, dust or metal powders) and any other area where you would normally be advised to turn off your vehicle engine. Areas with potentially explosive atmospheres are often – but not always posted.

#### Blasting Caps and Areas

To avoid possible interference with blasting operations, turn off your radio when you are near electrical blasting caps, in a blasting area, or in areas posted "Turn off two-way radios". Obey all signs and instructions.

#### Operational Cautions

##### Antennas

**Do not use any portable radio that has a damaged antenna.** If a damaged antenna comes into contact with your skin, a minor burn can result.

### Batteries

All batteries can cause property damage and/or bodily injury such as burns if a conductive material touches exposed terminals. The conductive material may complete an electrical circuit (short circuit) and become hot.

- Exercise care when removing NiMH or AA batteries. Do not use sharp or conductive tools to remove these batteries.
- Exercise care in handling any charged battery, particularly when placing it inside a pocket, purse or other container with metal objects.
- Do not discard your battery in a fire.
- Do not replace the battery in any area labeled "Hazardous Atmosphere". Any sparks created in a potentially explosive atmosphere can cause explosion or fire.
- Do not disassemble, crush, puncture, shred or otherwise attempt to change the form of your battery.
- Do not dry a wet battery or damp battery with an appliance or heat source, such as a hair dryer or microwave oven.
- If the radio battery contact area has been submerged in water, dry and clean the battery contacts before attaching the battery to the radio.

#### Battery Charger Safety Instructions:

##### Save these Instructions

1. Turn the radio off when charging the battery.
2. Do not expose the charger to outside environment. Chargers should only be used indoors.
3. Do not operate or disassemble the charger. Do not use a charger that has been dropped or damaged in any way.
4. Never alter the AC cord or plug provided with the unit. If the plug will not fit the outlet, have the proper outlet installed by a qualified electrician. An improper condition can result in a risk of electric shock.
5. To reduce the risk of damage to the cord or plug, pull the plug rather than the cord when disconnecting the charger from the AC receptacle.
6. To reduce the risk of electric shock, unplug the charger from the outlet before attempting any maintenance or cleaning.
7. Use of an attachment not recommended or sold by Motorola Solutions may result in a risk of fire, electric shock or personal injury.
8. Make sure the cord is located so it will not be stepped on, tripped over or subjected to damage or stress.
9. An extension cord should not be used unless absolutely necessary. Use of an improper extension cord could result in a risk of a fire and/or electric shock. If an extension cord must be used, make sure that:
  - The pins on the plug of the extension cord are the same number, size and shape as those on the plug of the charger.
  - The extension cord is properly wired and in good condition.
  - The extension cord size is 18 AWG for lengths up to 100 feet, and 16 AWG for lengths up to 150 feet.
10. The supply cord of the AC adaptor cannot be replaced. If the cord is damaged, call customer service at 1-800-448-6686 (Canada and U.S.).

### FCC Licensing Information

Your Motorola Solutions radio operates on General Mobile Radio Service (GMRS) frequencies and is subject to the Rules and Regulations of the Federal Communications Commission (FCC).

The FCC requires that all operators using GMRS frequencies obtain a radio license before operating their equipment. To obtain the FCC forms, please visit the FCC website at [wireless.fcc.gov/uls/index.htm?job=home](http://wireless.fcc.gov/uls/index.htm?job=home) to source form 605 and 159, which includes all the instructions you will need. If you wish to have the document faxed or mailed, or if you have questions, please use the following contact information:

| For a fax:<br>Contact the Fax-On-Demand system | For mail service:<br>Call the FCC Forms Hotline | If you have questions<br>about the FCC License:<br>Call the FCC |
|--|---|---|
| 1-202-418-0177                                 | 1-800-418-FORM (3678)                           | 1-888-CALL-FCC (225-5322)                                       |

Changes or modifications not expressly approved by Motorola Solutions may void the user authority granted by the FCC to operate this radio and should not be made. To comply with FCC requirements, transmitter adjustments should be made only by or under the supervision of a person certified as technically qualified to perform transmitter maintenance and repairs in the private land mobile and fixed services as certified by an organization representative of the user of those services. Replacement of any transmitter component (crystal, semiconductor, etc) not authorized by the FCC equipment authorization for this radio could violate FCC rules.

**Note:** Use of this radio outside the country where it was intended to be distributed is subject to government regulations and may be prohibited.

### Control Buttons

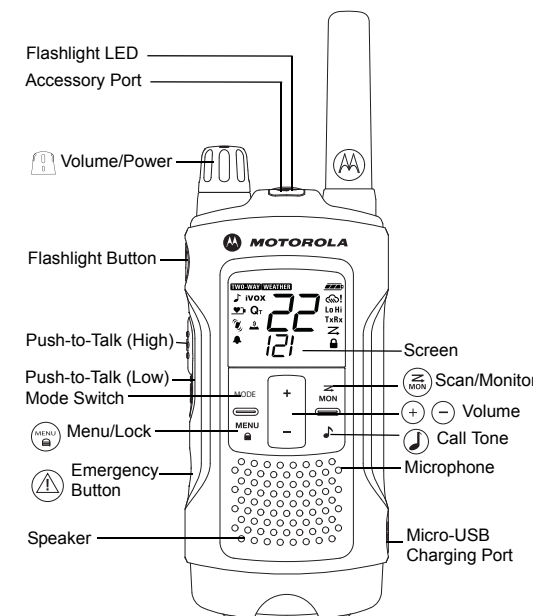

### Display Screen Guide

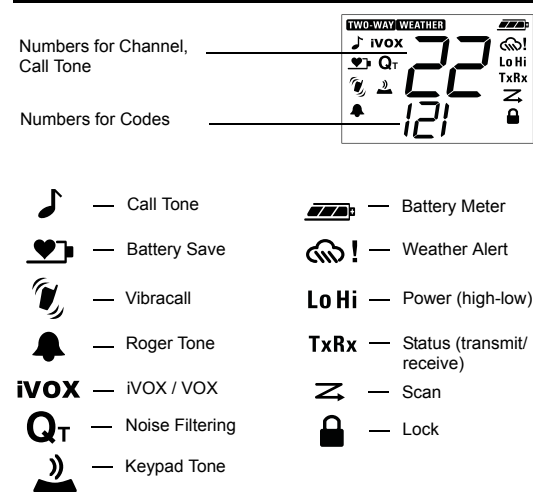

### Getting Started

#### Weatherproof

This radio is weatherproof to IP-54 standards. It is dust/splashproof from any direction. The radio is resistant to water and rain splashes only when the battery cover, headset accessory port, and micro-USB ports are sealed. Open the battery compartment door or headset port cover only when the radio is dry. Use of a headset accessory should be in dry environments only.

The micro-USB adaptor is not waterproof. Do not expose to rain or snow. Charge the radios only in a dry location. Do not charge wet radios. The battery door must be tightly closed with the screw to maintain the weatherproof seal of the radio.

#### Installing the Batteries

Each radio can use either 1 NiMH rechargeable battery pack or 3 AA alkaline batteries and beeps when the batteries are low.

#### Installing the NiMH Rechargeable Battery Pack (Optional Accessory)

1. Turn the radio off.
2. With the back of the radio facing you, loosen the retaining screw on the battery door and open the cover.
3. Remove the NiMH battery pack from the clear plastic bag (do not disassemble or unwrap the battery pack).
4. Insert the NiMH battery pack with the diagram facing you. (The ribbon should be underneath the battery pack and should wrap around the right side of the pack for easy removal).
5. Close the battery cover and tighten the retaining screw on the battery cover.

#### Installing the Three AA Alkaline Batteries

1. Turn the radio off.
2. With the back of the radio facing you, lift the battery cover latch up and remove the cover.
3. Insert the three AA Alkaline batteries with + and – polarity as shown inside. (The ribbon should be underneath the AA alkaline batteries and should wrap around the right side of the batteries).

4. Close the battery cover and tighten the retaining screw on the battery cover.

#### Radio Battery Meter

The radio battery icon shows the battery charge level, from full to empty . When the radio has one segment left, the radio chirps periodically or after releasing the PTT button (Low Battery Alert).

#### Removing the NiMH Battery Pack

1. Turn the radio off.
2. With the back of the radio facing you, loosen the retaining screw on the battery door and open the cover.
3. Remove the NiMH battery pack by pulling the ribbon attached to the radio.
4. Close the battery cover and tighten the retaining screw on the battery door.

#### Removing the Three AA Alkaline Batteries

1. Turn the radio off.
2. With the back of the radio facing you, loosen the retaining screw on the battery door and open the cover.
3. Gently remove each alkaline battery by easing each battery out individually.
4. Close the battery cover and tighten the retaining screw on the battery door.

#### Note:

- Exercise care when removing NiMH or AA batteries. Do not use sharp or conductive tools to remove either of these batteries.
- Remove the batteries before storing your radio for extended periods of time. Batteries corrode over time and may cause permanent damage to your radio.

#### Battery Capacity Maintenance

1. Charge the NiMH batteries once every 3 months when not in use.
2. Before placing the radio in storage, remove the battery. Store the NiMH batteries in temperature between -20 °C to 35 °C and in low humidity. Avoid damp conditions and corrosive materials.

#### Using the Micro-USB Charger

The micro-USB charger is a handy port that allows you to conveniently charge your NiMH battery pack.

1. Make sure your radio is turned OFF.
2. Plug the micro-USB cable into the micro-USB charging port on your radio. Connect the other end of the micro-USB charger to wall power outlet.
3. An empty battery will be fully charged in 14 hours.
4. The battery meter on LCD will move to indicate the battery is charging.

#### Note:

- It is recommended to power OFF your radio while charging. However, if power is on while charging, you may not be able to transmit a message if the battery is completely empty. Allow time for the battery to charge to 1 bar before attempting to transmit a message.
- When moving between hot and cold temperatures, do not charge the NiMH battery pack until the battery temperature acclimates (usually about 20 minutes).
- For optimal battery life, remove the radio from the charger within 16 hours. Do not store the radio while connected to the charger.

#### Attaching and Removing the Belt Clip

1. Attach the belt clip to the Talkabout plate at the back of the radio until the clip clicks in place.
2. Attach the belt clip to pocket or belt strap until the clip clicks in place.

#### To Remove

1. Push the release tab on top of the belt clip to release the latch.
2. Pull the belt clip away from the back of the radio.

#### Turning your Radio On and Off

Turn clockwise to turn the radio on and counterclockwise to turn the radio off.

1. In the ON position, the radio chirps and briefly shows all feature icons available on the radio.
2. The display screen then shows the current channel, code and all features that are enabled. The radio is now in Two-Way mode.

#### Setting the Volume

Press and hold for three seconds while rotating until you reach a comfortable listening level.

1. Rotate clockwise to increase the volume.
  2. Rotate counterclockwise to decrease the volume.
- Do not hold the radio close to your ear. If the volume is set to an uncomfortable level, it could hurt your ear.

### Talking and Listening

To communicate, all radios in your group must be set to the same channel and Interference Eliminator Code.

1. To talk, press and hold the PTT button. When transmitting, icon blinks and **Tx** is shown. If it is a high power transmission, **Hi** is shown. If it is a low power transmission, **Lo** is shown.
2. When you are finished talking, release the PTT button.
3. When receiving, icon blinks and **Rx** is shown. If it is a high power channel, **Hi** is shown. If it is a low power channel, **Lo** is shown.

For maximum clarity, hold the radio two to three inches away from your mouth and speak directly into the microphone. Do not cover the microphone while talking.

#### Talk Range

Your radio is designed to maximize performance and improve transmission range. Do not use the radios closer than five feet apart.

#### Power Boost

To boost the power of your radio to high power, press the top portion of the PTT button when talking. If you know your party is close by, you can conserve the energy of your battery by pushing the lower part of the PTT button to use less power.

**Note:** If you are on an FRS only channel (see "Channels and Frequencies") the radio will only use low power when either portion of the PTT button is pressed.

Power Boost is not applicable for model T400.

#### Monitor Button

Pressing and holding for three seconds allows you to listen to the volume level of the radio when you are not receiving. This allows you to adjust the volume, if necessary. You can also press to check for activity on the current channel before you talk.

#### Push-to-Talk Timeout Timer

To prevent accidental transmissions and save battery life, the radio emits a continuous warning tone and stops transmitting if you press the PTT button for 60 continuous seconds.

#### Mode Button

By pressing "mode" button, the user will be seamlessly switching between two-way and weather mode. When radio is in two-way mode, will be shown. When radio is in weather mode, will be shown. Corresponding setting and information will be shown on the LCD.

### Menu Options

#### Selecting the Channel

Your radio has 22 channels. The channel is the frequency the radio uses to transmit. Channels 8-14 are FRS 0.5 watt only and all other channels are GMRS. (See the "Channels and Frequencies" table on overleaf for details).

1. With the radio on, press until the channel number starts to flash. When the radio is on a 0.5 watt channel, display shows **LO**. When the radio is on a 1.5 watts channel, display shows **Hi**. The current channel flashes.
2. Press or and select an unused or quiet channel.
3. Press the PTT button to save the channel setting or to continue set up.

#### Selecting the Interference Eliminator Code

Interference Eliminator Codes help minimize interference by blocking transmissions from unknown sources. Your radio has 121 Interference Eliminator Codes. Codes 1 – 38 are standard analog codes that appear on other FRS/GMRS radios. Codes 39 – 121 are additional digital codes added for superior interference protection. 0 is the off position, no analog or digital codes are enabled.

To set the code for a channel:

1. Press until the code starts to flash.
2. Press or to select the code.
3. Press the PTT button to save the code setting or to continue set up.

You can set a different code for each channel using this procedure. An extended press of or allows you to scroll through the Interference Code rapidly so you can quickly reach the code you want.

**Note:** On a radio that uses Interference Eliminator Codes, the code must be set to 0 to communicate with radios that do not have Interference Eliminator Codes. Select 0 for "no tone, no code" on the display of your radio.



### Setting and Transmitting Call Tones

Your radio can transmit different call tones to other radios in your group so you can alert them that you want to talk. Your radio has 20 call tones from which to choose.

To set a call tone:

- Press **[MUTE]** until **[CALL TONE]** appears. The current call tone setting will flash.
- Press **[+]** or **[-]** to change and hear the call tone.
- Press the PTT button to set the new call tone or **[MUTE]** to continue set up.

To transmit your call tone to other radios set up to the same channel and Interference Eliminator Code as your radio, press **[CALL TONE]**.

**Note:** Setting the call to OFF disables the call tone feature.

### Hands-Free Use Without Accessories (iVOX)

You can use the **iVOX** feature to transmit hands-free without the need for any headset accessories. Once **iVOX** is turned on, the radio detects your voice and transmits when you speak into the internal microphone.

- Press **[iVOX]** until **iVOX** appears on the display. The current setting will flash.
- Press **[+]** or **[-]** to select On or Off or set sensitivity L1, L2 or L3.
- Press the PTT button to set or **[iVOX]** to continue set up.

### Hands-Free Use with Accessories (VOX)

You can transmit hands-free more reliable with the use of optional headset accessories. Once **VOX** is turned on, the radio detects your voice and transmits when you speak. Many accessories (sold separately) are available for your radio. For more information, visit our website at [www.motorolasolutions.com/TalkaboutAccessories](http://www.motorolasolutions.com/TalkaboutAccessories) or call 1-800-448-6686.

- Turn the radio off and plug the **VOX** accessory into the accessory port.
- Turn the radio on. **VOX** shows on the display.
- Adjust the volume appropriately by rotating **[VOLUME]**. Lower the volume before placing the accessory on your head or in your ear.
- To turn off, simply remove accessory.

**Note:** There is a short delay between the time you start talking and when the radio transmits. There is a short delay before the transmission is completed.

### Setting the Sensitivity Level When in VOX Mode

Adjusting the sensitivity level of the radio helps minimize the possibility of unintended noises triggering a transmission and helps the radio pick up soft voices.

- Press **[iVOX]** until **VOX** appears. The current setting (L1 – L3) will flash.
- Press **[+]** or **[-]** to select the sensitivity level.
- Press the PTT button to set or **[iVOX]** to continue set up.

**L3 = High Sensitivity** for quiet environments  
**L2 = Medium Sensitivity** for most environments  
**L1 = Low Sensitivity** for noisy environments

**Note:** When you connect a headset, the radio is automatically set to the last chosen sensitivity level.

### Setting the Extended Battery Save Level (♥)

This feature puts the radio into a low power "sleep" mode for cycle periods of 1, 2 or 3 seconds. The radio will briefly check for any channel activity after each sleep cycle. The sleep cycle repeats until a key is pressed or a call is received.

- Press **[BATTERY SAVE]** until **♥** appears. The current setting (L0, L1, L2 or L3) will flash.
- Press **[+]** or **[-]** to select the battery save level.
- Press the PTT button to set or **[BATTERY SAVE]** to continue set up.

**L0** = Normal battery save mode  
**L1** = 1 second extended battery save mode (low setting)  
**L2** = 2 seconds extended battery save mode (mid setting)  
**L3** = 3 seconds extended battery save mode (max setting)

### Note:

- Signals received during the sleep period will not be heard until after the timer period expires. The first 1 – 3 seconds of speech can be missed. Do not use **♥** (battery save) L1, L2 or L3 settings when immediate response may be required.
- Z**, **VOX**, **iVOX** and **Q** modes are not available with extended battery save mode. Using **Z**, **VOX**, **iVOX** or enabling **Q** will necessarily disable the extended sleep cycle battery settings.
- Maximum battery life savings may be achieved only when usage is primarily in standby mode and very little TX or RX (talking or listening) use occurs. When RX or TX are often used, little or no battery life extension will occur.

### Q Noise Filtering

The **Q** noise-filtering feature helps to ensure uninterrupted communication with other Motorola Solutions radios that have this feature. This feature also filters out unwanted transmissions from other radios. This is useful in places where there is heavy radio traffic, such as amusement parks or ski resorts.

**Note:** **Q** noise filtering is not available when the radio is scanning. **Q** noise filtering is not available when extended battery save is set to L1, L2 or L3. In consequence the **Q** will not appear in the Menu. You must set extended battery save to L0 in order to activate **Q** noise filtering.

To turn **Q** on or off:

- Press **[Q]** until **Q** displays. The current setting On/Off will flash.
- Press **[+]** or **[-]** to select On or Off.
- Press the PTT button to set or **[Q]** to continue set up.

To transmit to a radio that has **Q** noise filtering turned on:

- Select the same channel and Interference Eliminator Code as the other radio.
- Press **[Q]** to send a call tone. This allows your voice to pass through the **Q** noise filter on the receiving radio.
- Press the PTT button and speak normally.

**Note:** Without first pressing **[Q]**, your message will not be heard. After this, for a 30-second period, starting after the last transmission, all transmissions received on the selected channel and code will pass through the noise filter. When radio goes to idle, **[Q]** will need to be pressed again to allow communication to pass through.

### VibraCall™ Alert

VibraCall™ is a vibrating alert that notifies you that your radio is receiving a message. This is useful in noisy environments. When the alert is on, the radio vibrates once every 30 seconds when you receive a message on the channel and code you set.

- To turn vibrating alerts on, press **[VIBRA CALL]** until **[VIBRA CALL]** is displayed. The current setting will flash.
- Press **[+]** or **[-]** to change the setting to On/Off.
- Press the PTT button to confirm or **[VIBRA CALL]** to continue set up.

**Note:** VibraCall™ Alert is not applicable for model T400.

### Keypad Tones

You may enable or disable the speaker key tones. You will hear the key tone each time a button is pushed.

- Press **[KEYPAD TONES]** until **[KEYPAD TONES]** appears. The current setting On/Off will flash.
- Press either **[+]** or **[-]** to turn On or Off.
- Press the PTT button to confirm or **[KEYPAD TONES]** to continue set up.

**Note:** When the key tone feature is off, the following are not disabled:

- Transmit timeout alert tone
- Call tone
- Low battery alert tone or
- The transmitted talk confirmation tone

### Transmitting a Talk Confirmation Tone

You can set your radio to transmit a unique tone when you finish transmitting. It is like saying "Roger" or "Over" to let others know you are finished talking.

- With the radio on, press **[TALK CONFIRMATION TONE]** until **[TALK CONFIRMATION TONE]** appears. The current setting On/Off flashes.
- Press **[+]** or **[-]** to turn On or Off.
- Press the PTT button to set or **[TALK CONFIRMATION TONE]** to continue set up.

### Special Features

### Emergency Alert Mode

The Emergency Alert feature can be used to signal members in your group of your need for urgent help. T4XX series radios will operate in an automatic "hands-free" emergency control mode for a total of 30 seconds after activating the Emergency Alert. T4XX series radios in your group will automatically advance the speaker volume to the maximum setting and sound a warbling alert tone for 8 seconds. The alert tone is emitted from your own radio speaker and the receiving radios in your group. After the 8 second alert, any spoken words or incidental sounds at your end will be transmitted to the group for 22 seconds. For the 30 second duration of Emergency Alert mode, T4XX series radio controls and buttons will be locked to maximize reception of the emergency message.

- Press and hold the Emergency Alert button for 3 seconds.
- Release the button the alert tone begins to sound. There is no need to continue to hold the Emergency Alert button or use PTT for your message to be transmitted.
- After the alert tone ends you may speak into the microphone. Your voice or incidental sounds will be transmitted.
- After 30 seconds your radio speaker will emit a Talk Confirmation Tone. Operation then returns to normal two-way mode.

**Note:** All Motorola Talkabout EM, MJ, MR, MT, MU and T4XX series radios (except for model T400) are fully compatible with the Emergency Alert feature. Radios other than EM, MJ and MR series can receive the emergency alert signal, but will not respond with adjusted volume settings, locked controls or a warbling alert tone. Users of other radio models set to the same channel and Interference Eliminator Code will hear a steady tone for 8 seconds followed by the voice transmission for 22 seconds.

**WARNING: The Emergency Alert feature should only be used in the event of an actual emergency. Motorola Solutions is not responsible if there is no response to the emergency alert from the receiving group.**

### Built-in LED Flashlight with Power Outage Function

Press the flashlight button to turn and keep the light on. Press the flashlight button again, the light is off.

**Note:** Turn off the flashlight when not in use to conserve battery power.

### Keypad Lock

To avoid accidentally changing your radio settings:

- Press and hold **[KEYPAD LOCK]** until **[KEYPAD LOCK]** displays.
- When in lock mode, you can turn the radio on and off, adjust the volume, receive, transmit, send a call tone and monitor channels. All other functions are locked.
- To unlock the radio, press and hold **[KEYPAD LOCK]** until **[KEYPAD LOCK]** is no longer displayed.

### Scanning Channels

Use scan to search the 22 channels for transmissions from unknown parties, to find someone in your group who has accidentally changed channels or to quickly find unused channels for your own use.

There is a priority feature and 2 modes of scanning (basic and advanced) to make your search more effective. The basic scan mode uses the channel and code combinations for each of the 22 channels as you have set them (or with the default code value of 1). The "Advanced Scan" mode will scan all channels for any and all codes, detect any code in use and use that code value temporarily for that channel. Priority is given to the "home channel", that is, the channel (and Interference Eliminator Code) your radio is set to when you start the scan. This means the initial channel (and code settings) is scanned more often than the other 21 channels and your radio will respond quickly to any activity occurring on the home channel as a priority.

To start Scanning:

- Briefly press the **[SCAN]** key. The scan **Z** will appear in the display and the radio will begin to scroll through the channel and code combinations.
- When the radio detects channel activity matching the channel and code combination, it stops scrolling and you can hear the transmission.
- To respond and talk to the person transmitting, press the PTT button within five seconds after the end of the transmission.
- The radio will resume scrolling through the channels five seconds after the end of any received activity.
- To stop scanning, briefly press the **[SCAN]** key.

To start Advanced Scanning

- Set the Interference Eliminator Code to "zero" or OFF.
- Briefly press the **[SCAN]** key. The scan **Z** will appear in the display and the radio will begin to scroll through the channels. No Interference Eliminator Codes will filter what is heard.
- When the radio detects channel activity with ANY code (or NO code), it stops scrolling and you can hear the transmission. Any Interference Eliminator Code that may be in use by that party will be detected and displayed.
- To respond and talk to the person transmitting, press the PTT button within five seconds of the end of the transmission. The radio will transmit using the newly detected Interference Eliminator Code.
- The radio will resume scrolling through the channels five seconds after the end of any received activity.
- To stop scanning, briefly press the **[SCAN]**.

### Scanning Notes:

- If you press the PTT button while the radio is scrolling through inactive channels, the transmission will be on the "home channel". Scanning will resume five seconds after the end of your transmission. You may press the **[SCAN]** key to stop scanning at any time.
- If the radio stops on an undesired transmission, you may immediately resume the scan by briefly pressing **[+]** or **[-]**.
- If the radio repeatedly stops on an undesired transmission, you may temporarily remove that channel from the scan list by pressing and holding **[+]** or **[-]** for three seconds. You may remove more than one channel in this way.

- To restore the removed channel(s) to the scan list, turn the radio off and then turn back on, or exit and re-enter the scanning mode by pressing **[SCAN]**.

- You cannot remove the home channel from the scan list.
- In Advanced Scan, the detected code will only be used for one transmission. You must note that code, exit scan and set that detected code on that channel to permanently use the detected code.

### Weather Receiver

Your radio can tune in to broadcasts by the United States National Oceanic and Atmospheric Administration (NOAA) Weather Radio and Environment Canada Weather Radio. You can listen to a weather channel (see "Weather Channels and Frequencies" table for details) or set your radio to alert you to emergency weather broadcasts that interrupt routine broadcasts. When you listen to a weather channel, you cannot use your radio in scan mode or for two-way communications. Both NOAA and Environment Canada have transmitters located throughout the United States and Canada, respectively. These transmitters broadcast watches, forecasts and other information 24 hours a day.

**Note:** NOAA weather radio stations are assigned to cover specific areas and service may be limited. Please check with your local weather office for frequency and details or visit [www.weather.gov/nwr](http://www.weather.gov/nwr) in the US to view the appropriate transmitter for your area. The use of the NOAA logo does not provide an endorsement or implied endorsement by the National Weather Service of NOAA, nor does the use of the Weatheradio logo provide an endorsement or implied endorsement by Environment Canada.

### Entering Weather Mode

- From two-way mode, press **[MODE]** to enter weather mode

### WEATHER

### Setting the Weather Channel

Your radio receives weather frequencies:

- In weather mode, press **[CHANNEL]** until weather channel number flashes.
- Press **[+]** or **[-]** to select the appropriate channel with good reception in your area.
- Press the PTT button to set or **[CHANNEL]** to continue set up weather alert.

### Setting the Weather Alert

Your radio can be set to respond to NOAA Weather Radio emergency messages. A special alarm tone sounds an alert and turns on the weather receiver to give you immediate weather and emergency information.

- In weather mode press **[WEATHER ALERT]** twice until **[WEATHER ALERT]** displays.
- Press **[+]** or **[-]** to select On/Off.
- Press the PTT button or **[WEATHER ALERT]** to exit the weather menu set up.
- Press **[MODE]** to return to two-way mode. If you activate Weather Alert and return to two-way mode **[WEATHER ALERT]** will display.

**Note:** When the weather channel is activated, either manually or after receiving an alert, and no buttons are pressed for 5 minutes, the weather mode will automatically revert back to two-way mode.

As with two-way radio reception, weather channel reception depends on how close you are to a transmitter and whether you are indoors or outdoors. Because weather channels are transmitted without codes, they may contain static or noise. Weather Alert will not function while actively transmitting or receiving in two-way mode.

### Weather Channels and Frequencies

| Weather Channel | Frequency   | Weather Channel | Frequency   |
|-----------------|-------------|-----------------|-------------|
| WX1             | 162.550 MHz | WX7             | 162.525 MHz |
| WX2             | 162.400 MHz | WX8             | 161.650 MHz |
| WX3             | 162.475 MHz | WX9             | 161.775 MHz |
| WX4             | 162.425 MHz | WX10            | 161.750 MHz |
| WX5             | 162.450 MHz | WX11            | 162.000 MHz |
| WX6             | 162.500 MHz |                 |             |

### Channels and Frequencies

| Channel | Frequency    | Description | Channel | Frequency    | Description |
|---------|--------------|-------------|---------|--------------|-------------|
| 1       | 462.5625 MHz | GMRS/FRS    | 12      | 467.6625 MHz | FRS         |
| 2       | 462.5875 MHz | GMRS/FRS    | 13      | 467.6875 MHz | FRS         |
| 3       | 462.6125 MHz | GMRS/FRS    | 14      | 467.7125 MHz | FRS         |
| 4       | 462.6375 MHz | GMRS/FRS    | 15      | 462.5500 MHz | GMRS        |
| 5       | 462.6625 MHz | GMRS/FRS    | 16      | 462.5750 MHz | GMRS        |
| 6       | 462.6875 MHz | GMRS/FRS    | 17      | 462.6000 MHz | GMRS        |
| 7       | 462.7125 MHz | GMRS/FRS    | 18      | 462.6250 MHz | GMRS        |
| 8       | 467.5625 MHz | FRS         | 19      | 462.6500 MHz | GMRS        |
| 9       | 467.5875 MHz | FRS         | 20      | 462.6750 MHz | GMRS        |
| 10      | 467.6125 MHz | FRS         | 21      | 462.7000 MHz | GMRS        |
| 11      | 467.6375 MHz | FRS         | 22      | 462.7250 MHz | GMRS        |

### Patent and Copyright Information

MOTOROLA, MOTO, MOTOROLA SOLUTIONS and the Stylized M logo are trademarks or registered trademarks of Motorola Trademark Holdings, LLC and are used under license. All other trademarks are the property of their respective owners. © 2015 Motorola Solutions, Inc. All rights reserved.

### Warranty

### Consumer Two-Way Radio Products and Accessories purchased in the United States or Canada

### What Does this Warranty Cover?

Subject to the exclusions contained below, Motorola Solutions, Inc. ("Motorola") warrants the Motorola branded consumer two-way radios that operate via Family Radio Service or General Mobile Radio Service ("Products"), the Motorola branded or certified accessories sold for use with these Products ("Accessories") to be free from defects in materials and workmanship under normal consumer usage for the period(s) outlined below. This limited warranty is the exclusive remedy of a consumer, and applies as follows to new Products and Accessories and purchased by consumers in the United States or Canada, which are accompanied by this written warranty:

### Who is Covered?

This warranty extends only to the first consumer purchaser, and is not transferable.

### What will MOTOROLA SOLUTIONS, INC. do?

Motorola Solutions, Inc., at its option, will at no charge repair, replace or refund the purchase price of any Products or Accessories that do not conform to this warranty. We may use functionally equivalent reconditioned/ refurbished/ pre-owned or new Products or Accessories.

### What Other Limitations Are There?

**Any Implied Warranties, Including Without Limitation** The implied warranties of merchantability and fitness for a particular purpose, shall be limited to the duration of this limited warranty, otherwise the repair, replacement, or refund as provided under this express limited warranty is the exclusive remedy of the consumers, and is provided in lieu of all other warranties, express or implied. In no event shall Motorola Solutions be liable, whether in contract or tort (including negligence) for damages in excess of the purchase price of the product or accessory, or for any indirect, incidental, special or consequential damages of any kind, or loss of revenue or profits, loss of business, loss of information or other financial loss arising out of or in connection with the ability or inability to use the products or accessories to the full extent these damages may be disclaimed by law.

Some states and jurisdictions do not allow the limitation or exclusion of incidental or consequential damages, or limitation on the length of an implied warranty, so the above limitations or exclusions may not apply to you. This warranty gives you specific legal rights, and you may also have other rights that vary from state to state or from one jurisdiction to another.

| Products Covered   | Length Of Coverage  |
|--|---|
| <b>Products and Accessories</b> as defined above, unless otherwise provided for below:                 | <b>One (1) year</b> from the date of purchase by the first consumer purchaser of the product unless otherwise provided for below. |
| Batteries whose fully charged capacity falls below 80% of their rated capacity and batteries that leak |   |
| <b>Products and Accessories</b> that are repaired or replaced  | <b>The balance of the original warranty or for ninety (90) days</b> from the date returned to the consumer, whichever is longer.  |

### Exclusions From Warranty Coverage

**Normal Wear and Tear:** Periodic maintenance, repair and replacement of Products or Accessories due to normal wear and tear.

**Abuse & Misuse:** Defects or damage that result from: (a) improper operation, storage, misuse or abuse, accident or neglect, such as physical damage (cracks, scratches, etc.) to the surface of the Products and Accessories resulting from misuse; (b) contact with liquid, water, rain, extreme humidity or heavy perspiration, sand, dirt or the like, extreme heat, or food; (c) use of the Products or Accessories for commercial purposes or subjecting the Product or Accessory to abnormal usage or conditions; or (d) other acts which are not the fault of Motorola.

**Use of Non-Motorola branded Products and Accessories:** Defects or damage that result from the use of Non-Motorola branded or certified products, accessories, software or other peripheral equipment.

**Unauthorized Service or Modification:** Defects or damages resulting from service, testing, adjustment, installation, maintenance, alteration, or modification in any way by someone other than Motorola or its authorized service centers.

**Altered Products:** Products or Accessories with (a) serial numbers or date tags that have been removed, altered or obliterated; (b) broken seals or that show evidence of tampering; (c) mismatched board serial numbers; or (d) nonconforming or non-Motorola branded housings, or parts.

**Communication Services:** Defects, damages, or the failure of Products or Accessories due to any communication service or signal you may subscribe to or use with the Products or Accessories.

### How to Obtain Warranty Service or Other Information?

To obtain service or information, please call

**USA and Canada Two-Way Radios**  
 1-800-448-6686.  
[www.motorolasolutions.com/talkabout](http://www.motorolasolutions.com/talkabout)

**For Accessories:** Please call the telephone number designated above for the Product with which they are used.

You will receive instructions on how to ship the Products or Accessories at your expense, to Motorola or a Motorola Authorized Repair Center. To obtain service, you must include: (a) a copy of your receipt, bill of sale or other comparable proof of purchase; (b) a written description of the problem; (c) the name of your service provider, if applicable; (d) the name and location of the installation facility (if applicable) and, most importantly; (e) your address and telephone number.

### For more information, please visit us at:

 <https://www.facebook.com/MotorolaTalkaboutWalkieTalkies>

 <http://bit.ly/Talkabout>

 [www.motorolasolutions.com/talkabout](http://www.motorolasolutions.com/talkabout)