



PROFESSIONAL DIGITAL TWO-WAY RADIO

MOTOTRBO^{MC} XPR 3500/XPR 3500e

LIMITED KEYPAD PORTABLE
PORTATIVES AVEC CLAVIER LIMITÉ

en

USER GUIDE

fr-CA

GUIDE DE L'UTILISATEUR

Contents



Declaration of Conformity.....	6	Preparing Your Radio for Use.....	13
Important Safety Information.....	8	Charging the Battery.....	13
Software Version.....	9	Attaching the Battery.....	13
Computer Software Copyrights....	10	Attaching the Antenna.....	14
Handling Precautions.....	11	Attaching the Belt Clip.....	15
Getting Started.....	12	Attaching the Universal Connector Cover (Dust Cover).....	15
How to Use This Guide.....	12	Attaching the Accessory Connector.....	16
What Your Dealer/System Administrator Can Tell You.....	12	Powering Up the Radio.....	17
		Adjusting the Volume.....	18
		Identifying Radio Controls.....	19
		Radio Controls.....	19
		Programmable Buttons.....	20
		Assignable Radio Functions.....	20
		Assignable Settings or Utility Functions.....	22
		Accessing the Programmed Functions.....	22
		Push-To-Talk (PTT) Button.....	23
		Switching Between Conventional Analog and Digital Mode.....	24
		IP Site Connect.....	25
		Capacity Plus.....	25



Linked Capacity Plus.....	26
---------------------------	----

Identifying Status Indicators.....28

Display Icons.....	28
Call Icons.....	30
Advanced Menu Icons.....	31
Mini Notice Icons.....	31
Sent Item Icons 	31
LED Indicator.....	31
Alert Tones.....	33
Indicator Tones.....	33









Making and Receiving Calls.....34



Selecting a Zone.....	34
Selecting a Channel.....	34
Receiving and Responding to a Radio Call... 35	
Receiving and Responding to a Group Call.....	35
Receiving and Responding to a Private Call 	36
Receiving an All Call	37
Receiving and Responding to a Selective Call 	37
Making a Radio Call.....	38

Making a Radio Call.....	41
Making a Group Call.....	42
Making a Private Call 	42
Making an All Call	43
Making a Selective Call 	44
Stopping a Radio Call 	45
Talkaround.....	45
Monitoring Features.....	46
Monitoring a Channel.....	46
Permanent Monitor.....	46

Advanced Features.....48

Radio Check.....	48
Sending a Radio Check.....	48
Scan Lists.....	48
Viewing an Entry in the Scan List.....	49
Editing the Scan List.....	49
Scan.....	51
Starting and Stopping Scan.....	51
Responding to a Transmission During a Scan.....	52
Deleting a Nuisance Channel.....	52
Restoring a Nuisance Channel.....	53
Vote Scan 	53
Contact Settings.....	53

Making a Group Call from Contacts.....	54	Emergency Operation.....	63
Making a Private Call from		Sending an Emergency Alarm.....	64
Contacts 	55	Sending an Emergency Alarm with	
Setting a Default Contact 	55	Call.....	64
Call Indicator Settings.....	56	Sending an Emergency Alarm with	
Activating and Deactivating Call		Voice to Follow 	65
Ringers for Call Alert 	56	Reinitiating an Emergency Mode.....	67
Activating and Deactivating Call		Exiting Emergency Mode After	
Ringers for Private Calls 	57	Sending the Emergency Alarm.....	67
Activating and Deactivating Call		Privacy 	67
Ringers for Selective Call 	57	Security.....	69
Assigning Ring Styles.....	58	Radio Disable.....	69
Selecting a Ring Alert Type.....	58	Radio Enable.....	71
Configuring Vibrate Style.....	59	Lone Worker.....	72
Escalating Alarm Tone Volume.....	60	Password Lock Features.....	73
Call Log Features.....	60	Accessing the Radio from	
Viewing Recent Calls.....	60	Password.....	73
Deleting a Call from a Call List.....	61	Unlocking the Radio from Locked	
Viewing Details from a Call List.....	61	State.....	74
Call Alert Operation.....	62	Turning the Password Lock On or	
Receiving and Responding to a		Off.....	74
Call Alert.....	62	Changing the Password.....	75
Making a Call Alert from the		Notification List.....	76
Contact List.....	62	Accessing the Notification List.....	76
Making a Call Alert with the One		Auto-Range Transponder System (ARTS)	
Touch Access Button.....	63		76

Over-the-Air-Programming (OTAP).....	76	Turning the Voice Announcement On or Off.....	86
Wi-Fi Operation.....	77	Call Forwarding 	87
Turning Wi-Fi On or Off.....	77	Menu Timer.....	88
Connecting to a Network Access Point.....	78	Analog Mic AGC (Mic AGC-A).....	88
Viewing Details of Network Access Points.....	78	Digital Mic AGC (Mic AGC-D).....	89
Utilities.....	78	Intelligent Audio.....	90
Setting the Squelch Level.....	78	Turning the Acoustic Feedback Suppressor Feature On or Off 	91
Setting the Power Level.....	79	Accessing General Radio Information.....	92
Adjusting the Display Brightness.....	80	Checking the RSSI Values.....	94
Turning the Voice Operating Transmission (VOX) Feature On or Off.....	81	Front Panel Configuration (FPC).....	94
Setting the Display Backlight Timer....	82		
Turning the Radio Tones/Alerts On or Off.....	82		
Turning the Power Up Alert Tone On or Off.....	83		
Setting the Tone Alert Volume Offset Level.....	84		
Turning the Talk Permit Tone On or Off.....	84		
Language.....	85		
Turning the LED Indicator On or Off...	85		
Turning the Introduction Screen On or Off.....	86		

Authorized Accessories List.....96

Antennas.....	96
Batteries.....	96
Carry Devices.....	97
Chargers.....	97
Earbuds and Earpieces.....	97
Headsets and Headset Accessories.....	98
Remote Speaker Microphones.....	98
Surveillance Accessories.....	98
Miscellaneous Accessories.....	98

Batteries and Chargers Warranty..... 100

The Workmanship Warranty.....	100	
The Capacity Warranty.....	100	
Limited Warranty.....	101	
MOTOROLA COMMUNICATION		
PRODUCTS.....	101	
I. WHAT THIS WARRANTY COVERS		
AND FOR HOW LONG:.....	101	
II. GENERAL PROVISIONS:.....		102
III. STATE LAW RIGHTS:.....		102
IV. HOW TO GET WARRANTY SERVICE:..		102
V. WHAT THIS WARRANTY DOES NOT		
COVER:.....	103	
VI. PATENT AND SOFTWARE		
PROVISIONS:.....	103	
VII. GOVERNING LAW:.....		105

Declaration of Conformity

This declaration is applicable to your radio only if your radio is labeled with the FCC logo shown below.

Declaration of Conformity

Per FCC CFR 47 Part 2 Section 2.1077(a)



Responsible Party

Name: Motorola Solutions, Inc.

Address: 1303 East Algonquin Road, Schaumburg, IL 60196-1078, U.S.A.

Phone Number: 1-800-927-2744

Hereby declares that the product:

Model Name: **XPR 3500/XPR 3500e**

conforms to the following regulations:

FCC Part 15, subpart B, section 15.107(a), 15.107(d) and section 15.109(a)

Class B Digital Device

As a personal computer peripheral, this device complies with Part 15 of the FCC Rules. This device complies with Industry Canada licence-exempt RSS standard(s). Operation is subject to the following two conditions:

- 1 This device may not cause harmful interference, and
- 2 This device must accept any interference received, including interference that may cause undesired operation.



Note:

This equipment has been tested and found to comply with the limits for a Class B digital device, pursuant to part 15 of the FCC Rules. These limits are designed to provide reasonable protection against harmful interference in a residential installation. This equipment generates, uses and can radiate radio frequency energy and, if not installed and used in accordance with the instructions, may cause harmful interference to radio communications. However, there is no guarantee that interference will not occur in a particular installation.

If this equipment does cause harmful interference to radio or television reception, which can be determined by turning the equipment off and on, the user is encouraged to try to correct the interference by one or more of the following measures:

- Reorient or relocate the receiving antenna.
- Increase the separation between the equipment and receiver.
- Connect the equipment into an outlet on a circuit different from that to which the receiver is connected.
- Consult the dealer or an experienced radio or TV technician for help.

Appareil numérique de Classe B

En tant que périphérique d'ordinateur personnel, cet appareil est conforme aux stipulations de la partie 15 des règlements de la FCC. Cet appareil est conforme aux CNR d'Industrie Canada applicables aux appareils radio exempts de licence. Son utilisation est assujettie aux deux conditions suivantes :

- 1 Cet appareil ne doit pas causer d'interférence nuisible.
- 2 Cet appareil doit accepter toute interférence reçue, y compris les interférences pouvant entraîner un fonctionnement indésirable.



Remarque

Ce matériel a fait l'objet de tests et a été déclaré conforme aux limites établies pour un appareil numérique de classe B, comme il est stipulé à la section 15 des règlements de la FCC. Ces limites sont fixées afin d'offrir une protection suffisante contre des interférences nuisibles dans une installation résidentielle. Ce matériel génère, utilise et peut émettre de l'énergie radiofréquence et, s'il n'est pas installé ni utilisé conformément aux instructions, il peut provoquer un brouillage nuisible aux communications radio. Cependant, on ne peut garantir qu'il n'y aura aucune interférence dans une installation particulière.

Si cet appareil cause une interférence nuisible de la réception de la radio ou de la télévision, ce qui peut être déterminé en éteignant et en allumant l'appareil, vous êtes encouragé à remédier à la situation en prenant une ou plusieurs des mesures suivantes :

- Réorienter ou déplacer l'antenne réceptrice.
- Augmenter la distance entre l'équipement et le récepteur.
- Brancher l'appareil dans une autre prise sur un circuit différent de celui du récepteur.
- Consulter un revendeur ou un technicien radio/télévision chevronné pour obtenir de l'aide.

Important Safety Information

RF Energy Exposure and Product Safety Guide for Portable Two-Way Radios

ATTENTION!

This radio is restricted to Occupational use only.

Before using the radio, read the RF Energy Exposure and Product Safety Guide for Portable Two-Way Radios which contains important operating instructions for safe usage and RF energy awareness and control for Compliance with applicable standards and Regulations.

For a list of Motorola-approved antennas, batteries, and other accessories, visit the following website:

<http://www.motorolasolutions.com>

Any modification to this device, not expressly authorized by Motorola, may void the user's authority to operate this device.

Under Industry Canada regulations, this radio transmitter may only operate using an antenna of a type and maximum (or lesser) gain approved for the transmitter by Industry Canada. To reduce potential radio interference to other users, the antenna type

and its gain should be so chosen that the equivalent isotropically radiated power (e.i.r.p.) is not more than that necessary for successful communication.

This radio transmitter has been approved by Industry Canada to operate with Motorola-approved antenna with the maximum permissible gain and required antenna impedance for each antenna type indicated. Antenna types not included in this list, having a gain greater than the maximum gain indicated for that type, are strictly prohibited for use with this device.

Consignes de sécurité importantes

Radios bidirectionnelles portatives : exposition aux radiofréquences et sécurité du produit

ATTENTION!

Cette radio ne doit être utilisée qu'à des fins professionnelles. Avant d'utiliser la radio, lisez le guide Radios bidirectionnelles portatives : exposition aux radiofréquences et sécurité du produit, qui contient d'importantes instructions de fonctionnement pour une utilisation sécuritaire et des informations sur l'exposition aux fréquences radioélectriques, dans le but d'assurer votre conformité aux normes et règlements en vigueur.

Visitez le site Web suivant pour obtenir la liste des antennes, des batteries et des autres accessoires approuvés par Motorola :

<http://www.motorolasolutions.com>

Toute modification effectuée à cet appareil sans l'autorisation explicite de Motorola peut annuler l'autorisation d'utiliser cet appareil.

Selon la réglementation d'Industrie Canada, cet émetteur radio ne peut être utilisé qu'avec une

antenne dont le type et le gain maximal (ou minimal) sont approuvés par Industrie Canada pour cet émetteur. Afin de limiter les interférences radio pour les autres utilisateurs, le type et le gain de l'antenne doivent être choisis de façon à ce que la puissance isotrope rayonnée équivalente (P.I.R.E.) ne soit pas plus forte qu'il ne le faut pour établir la communication.

Cet émetteur radio a été approuvé par Industrie Canada pour utilisation avec une antenne approuvée par Motorola offrant le gain maximal autorisé et l'impédance requise pour le type d'antenne indiqué. Il est strictement interdit d'utiliser avec cet appareil tout type d'antenne ne figurant pas dans cette liste et présentant un gain supérieur au maximum indiqué pour le type.

Software Version

All the features described in the following sections are supported by the software version **R02.50.00** or later.

See [Checking the Firmware Version and Codeplug Version](#) on page 93 to determine the software version of your radio.

Check with your dealer or system administrator for more details of all the features supported.

Version logicielle

Toutes les fonctions décrites dans les sections suivantes sont prises en charge par la version **R02.50.00** ou les versions ultérieures du logiciel de la radio.

Consultez la section [Checking the Firmware Version and Codeplug Version](#) pour connaître la version logicielle de votre radio.

Pour obtenir davantage de renseignements à propos des fonctions prises en charge, adressez-vous à votre détaillant ou à votre administrateur de système.

Computer Software Copyrights

The Motorola products described in this manual may include copyrighted Motorola computer programs stored in semiconductor memories or other media. Laws in the United States and other countries preserve for Motorola certain exclusive rights for copyrighted computer programs including, but not limited to, the exclusive right to copy or reproduce in any form the copyrighted computer program. Accordingly, any copyrighted Motorola computer programs contained in the Motorola products described in this manual may not be copied, reproduced, modified, reverse-engineered, or distributed in any manner without the express written permission of Motorola. Furthermore, the purchase of Motorola products shall not be deemed to grant either directly or by implication, estoppel, or otherwise, any license under the copyrights, patents or patent applications of Motorola, except for the normal non-exclusive license to use that arises by operation of law in the sale of a product.

The AMBE+2™ voice coding Technology embodied in this product is protected by intellectual property rights

including patent rights, copyrights and trade secrets of Digital Voice Systems, Inc.

This voice coding Technology is licensed solely for use within this Communications Equipment. The user of this Technology is explicitly prohibited from attempting to decompile, reverse engineer, or disassemble the Object Code, or in any other way convert the Object Code into a human-readable form.

U.S. Pat. Nos. #5,870,405, #5,826,222, #5,754,974, #5,701,390, #5,715,365, #5,649,050, #5,630,011, #5,581,656, #5,517,511, #5,491,772, #5,247,579, #5,226,084 and #5,195,166.

Handling Precautions

The MOTOTRBO Series Digital Portable radio meets IP55 specifications, allowing the radio to withstand adverse field conditions such as being used in rain or dusty environment.

- If the radio has been exposed to water or rain, shake the radio well to remove any water that may be trapped inside the speaker grille, microphone port and aesthetic cover (if applicable). Trapped water in speaker grille and microphone port could cause decreased audio performance. If aesthetic cover is attached onto radio, trapped water in aesthetic cover could cause corrosion on the slim connector interface gold contacts.
- If the radio's battery contact area has been exposed to water, clean and dry battery contacts on both the radio and the battery before attaching the battery to the radio. The residual water could short-circuit the radio.
- If the radio has been exposed to a corrosive substance (e.g. saltwater), rinse the radio and battery in fresh water then dry the radio and battery.

- To clean the exterior surfaces of the radio, use a diluted solution of mild dishwashing detergent and fresh water (i.e. one teaspoon of detergent to one gallon of water).
- The radio with antenna attached properly is designed to be protected against dust and low pressure jets of water projected with nozzle 6.3 mm diameter at flow rate of 12.5 l/min, with water pressure at 30 kN/m² and from a distance of 2.5 meter to 3 meter for at least 3 minutes. Exceeding either maximum limit or use without antenna may result in damage to the radio.
- When cleaning the radio, do not use a high pressure jet spray on the radio as this may cause water to leak into the radio.



Caution:

Do not disassemble the radio. This could damage radio seals and result in leak paths into the radio. Radio maintenance should only be done in service depot that is equipped to test and replace the seal on the radio.

Getting Started

How to Use This Guide

This User Guide covers the basic operation of the MOTOTRBO Portables.

However, your dealer or system administrator may have customized your radio for your specific needs. Check with your dealer or system administrator for more information.

Throughout this publication, the icons described next are used to indicate features supported in either the conventional Analog mode or conventional Digital mode:



Indicates a conventional **Analog Mode-Only** feature.



Indicates a conventional **Digital Mode-Only** feature.

For features that are available in **both** conventional Analog and Digital modes, **no** icon is shown.

What Your Dealer/System Administrator Can Tell You

You can consult your dealer or system administrator about the following:

- Is your radio programmed with any preset conventional channels?
- Which buttons have been programmed to access other features?
- What optional accessories may suit your needs?
- What are the best radio usage practices for effective communication?
- What maintenance procedures will help promote longer radio life?

Preparing Your Radio for Use

Charging the Battery

**Important:**

ALWAYS charge your IMPRES battery with an IMPRES charger for optimized battery life and valuable battery data. IMPRES batteries charged exclusively with IMPRES chargers receive a 6-month capacity warranty extension over the standard Motorola Premium battery warranty duration.

Your radio is powered by a Lithium-Ion (Li-Ion) battery. To avoid damage and to ensure compliance with warranty terms, charge the battery using a Motorola charger *exactly* as described in the charger user guide. It is recommended your radio remains powered off while charging.

Charge a new battery 14 to 16 hours before initial use for best performance.

Attaching the Battery

**Note:**

If user inadvertently attaches a UL battery to an FM approved radio or vice versa, the certification on the radio will be voided. Your radio can be preprogrammed via CPS to alert you if this battery mismatch occurs. Check with your dealer or system administrator to determine how your radio has been programmed. This battery mismatch alert feature is only applicable for IMPRES battery and Non-IMPRES battery with kit number programmed in Erasable Programmable Read Only Memory (EPROM).

When the radio is attached with the wrong battery, a low pitched warning tone sounds, the LED lights up blinking red, display shows `Wrong Battery` and the Voice Announcement/Text-to-Speech sounds `Wrong Battery` if the Voice Announcement/Text-to-Speech is loaded via CPS.

- 1 Align the battery with the rails on the back of the radio. Press the battery firmly, and slide upwards until the latch snaps into place.

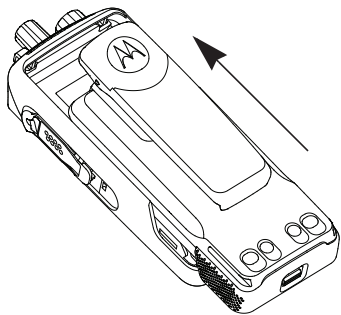

- 2 To remove the battery, turn the radio off. Move the battery latch (A) into unlock position and hold, and slide the battery down and off the rails.

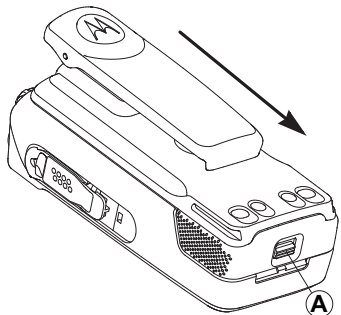

Attaching the Antenna



Caution:

If antenna needs to be replaced, ensure that only MOTOTRBO antennas are used. Neglecting this will damage your radio.

- 1 With the radio turned off, set the antenna in its receptacle and turn clockwise.

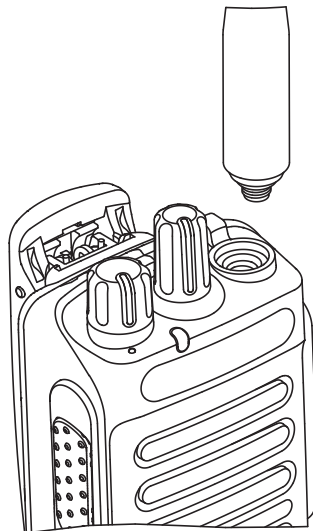

- 2 To remove the antenna, turn the antenna counterclockwise.

Attaching the Belt Clip

- 1 To attach the belt clip, align the grooves on the clip with those on the battery and press downward until you hear a click.

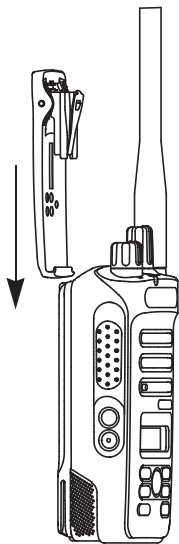

- 2 To remove the belt clip, press the belt clip tab away from the battery using a key. Then slide the clip upward and away from the radio.

Attaching the Universal Connector Cover (Dust Cover)

The universal connector is located on the antenna side of the radio. It is used to connect MOTOTRBO accessories to the radio.

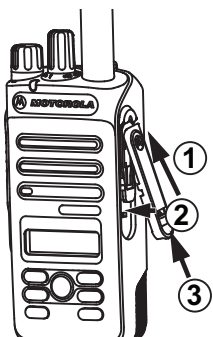

Insert the slanted end of the cover into the slots above the universal connector. Press downward on the cover to seat the dust cover properly on the Universal Connector.

Secure the dust cover to the radio by pushing the latch upwards.

To remove the dust cover, push the latch downwards. Lift up the cover and slide down the dust cover from the universal connector to remove it.

Replace the dust cover when the universal connector is not in use.

If the radio is exposed to water, dry the universal connector before attaching an accessory or replacing the dust cover.

If the radio is exposed to salt water or contaminants, perform the following cleaning procedure.

- 1 Mix one tablespoon of mild dishwashing detergent with one gallon of water to produce a 0.5 percent solution.
- 2 Clean only the external surfaces of the radio with the solution. Apply the solution sparingly with a stiff, nonmetallic, short-bristled brush.
- 3 Dry the radio thoroughly with a soft and lint-free cloth. Ensure the contact surface of the universal connector is clean and dry.

- 4 Apply Deoxit Gold Cleaner or Lubricant Pen (Manufacturer CAIG Labs, Part number G100P) on the contact surface of the universal connector.

- 5 Attach an accessory to the universal connector to test the connectivity.

**Note:**

Do not submerge the radio in water. Ensure excess detergent does not get trapped in between the universal connector, controls, or crevices.

Clean the radio once a month for maintenance. For a harsher environment such as in petrochemical plants or in a high salt density marine environment, clean the radio more often.

Attaching the Accessory Connector

The accessory connector is to be secured to the universal connector on the antenna side of the radio.

- 1 To attach the accessory connector, refer to the steps shown in the diagram.

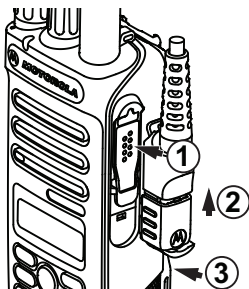

- 2 To remove the accessory connector, refer to the steps shown in the diagram.

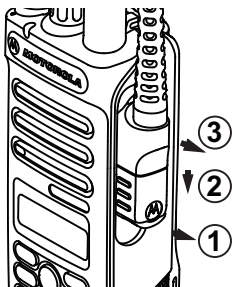

Powering Up the Radio

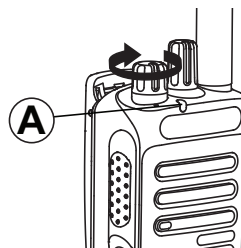

Rotate the **On/Off/Volume Control Knob** clockwise until you hear a click. You see **MOTOTRBO (TM)** on the display of the radio momentarily, followed by a welcome message.

The LED lights up solid green (A) and the Home screen lights up if the backlight setting is set to turn on automatically.

A brief tone sounds, indicating that the power up test is successful.



Note:

There is no power up tone if the radio tones/alerts function is disabled (see [Turning the Radio Tones/Alerts On or Off](#) on page 82).

Turn off the radio by rotating this knob counterclockwise until you hear a click. You see a brief `Powering Down` on the display of the radio.

Adjusting the Volume

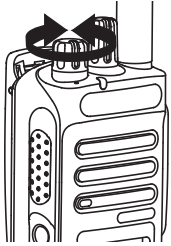

Increase the volume by turning the **On/Off/Volume Control Knob** clockwise.

Decrease the volume by turning this knob counterclockwise.



Note:

Your radio can be programmed to have a minimum volume offset where the volume level cannot be lowered past the programmed minimum volume. Check with your dealer or system administrator for more information.

Identifying Radio Controls

Radio Controls



- 1 Channel Selector Knob
- 2 On/Off/Volume Control Knob
- 3 LED Indicator
- 4 Push-to-Talk (PTT) Button
- 5 Microphone
- 6 Side Button 1^[1]
- 7 Side Button 2^[1]
- 8 Left Navigation Button
- 9 Menu Button
- 10 Front Button P1^[1]
- 11 OK Button
- 12 Front Button P2^[1]
- 13 Back/Home Button
- 14 Right Navigation Button
- 15 Display
- 16 Speaker
- 17 Universal Connector for Accessories
- 18 Antenna

¹ These buttons are programmable.

Programmable Buttons

Your dealer can program the programmable buttons as shortcuts to radio functions depending on the duration of a button press:

Short press Pressing and releasing rapidly.

Long press Pressing and holding for the programmed duration.

Press and hold Keeping the button pressed.



Note:

The programmed duration of a button press is applicable for all assignable radio/utility functions or settings. See [Emergency Operation](#) on page 63 for more information on the programmed duration of the **Emergency** button.

Assignable Radio Functions

Audio Profiles Allows the user to select the preferred audio profile.

Audio Routing Toggles audio routing between internal and external speakers.

Audio Toggle

Toggles audio routing between the internal radio speaker and the speaker of wired accessory.

Contacts

Provides direct access to the Contacts list.

Call Alert

Provides direct access to the contacts list for you to select a contact to whom a Call Alert can be sent.

Call Forwarding

Toggles Call Forwarding on or off.

Call Log

Selects the call log list.

Channel Announcement







Plays zone and channel announcement voice messages for the current channel.

Emergency

Depending on the programming, initiates or cancels an emergency.

Intelligent Audio

Toggles intelligent audio on or off.

Manual Site Roam 	Starts the manual site search.	Permanent Monitor	Monitors a selected channel for all radio traffic until function is disabled.
Mic AGC On/Off	Toggles the internal microphone automatic gain control (AGC) on or off.	Phone	Provides direct access to the Phone Contacts list.
Monitor	Monitors a selected channel for activity.	Privacy 	Toggles privacy on or off.
Notifications	Provides direct access to the Notifications list.	Radio Alias and ID	Provides radio alias and ID.
Nuisance Channel Delete	Temporarily removes an unwanted channel, except for the Selected Channel, from the scan list. The Selected Channel refers to the selected zone or channel combination of the user from which scan is initiated.	Radio Check 	Determines if a radio is active in a system.
One Touch Access 	Directly initiates a predefined Private, Phone or Group Call, a Call Alert or a Quick Text message.	Radio Enable 	Allows a target radio to be remotely enabled.
		Radio Disable 	Allows a target radio to be remotely disabled.
		Repeater/ Talkaround	Toggles between using a repeater and communicating directly with another radio.
		Scan	Toggles scan on or off.
		Site Lock On/Off 	When toggled on, the radio searches the current site only. When toggled off, the radio

	searches other sites in addition to the current site.
Text Message	Selects the text message menu.
Transmit Interrupt Remote Dekey 	Stops an ongoing interruptible call to free the channel.
Trill Enhancement On/Off	Toggles trill enhancement on or off.
Voice Announcement On/Off	Toggles voice announcement on or off.
Voice Operating Transmission (VOX)	Toggles VOX on or off.
Zone	Allows selection from a list of zones.

Assignable Settings or Utility Functions



All Tones/Alerts	Toggles all tones and alerts on or off.
Backlight	Toggles display backlight on or off.
Backlight Brightness	Adjusts the brightness level.
Power Level	Toggles transmit power level between high and low.
Squelch 	Toggles squelch level between tight and normal.

Accessing the Programmed Functions



You can access various radio functions through one of the following ways:



- A short or long press of the relevant programmable buttons.
- Use the Menu Navigation Buttons as follows:

1 Press  to access the menu. Press the appropriate Menu Scroll button ( or ) to access the menu functions.

2 To select a function or enter a sub-menu, press the  button.

3 To go back one menu level, or to return to the previous screen, press the  button. Long press the  button to return to the Home screen.



Note:

Your radio automatically exits the menu after a period of inactivity and returns to your Home screen.

Push-To-Talk (PTT) Button

The **PTT** button on the side of the radio () serves two basic purposes:

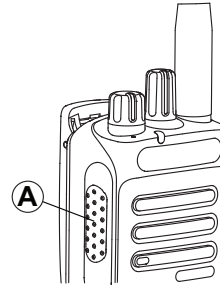

- While a call is in progress, the **PTT** button allows the radio to transmit to other radios in the call.
Press and hold the **PTT** button to talk. Release the **PTT** button to listen.
The microphone is activated when the **PTT** button is pressed.
- While a call is not in progress, the **PTT** button is used to make a new call (see [Making a Radio Call](#) on page 38).

If the Talk Permit Tone (see [Turning the Talk Permit Tone On or Off](#) on page 84)  is enabled, wait until the short alert tone ends before talking.

 During a call, if the Channel Free Indication feature is enabled on your radio (programmed by your

dealer), you will hear a short alert tone the moment the target radio (the radio that is receiving your call) releases the **PTT** button, indicating the channel is free for you to respond.

 You will also hear a continuous talk prohibit tone, if your call is interrupted, indicating that you should release the **PTT** button, for example when the radio receives an Emergency Call.

Switching Between Conventional Analog and Digital Mode

Each channel in your radio can be configured as a conventional analog or conventional digital channel. Use the Channel Selector Knob (A) to switch between an analog or a digital channel.

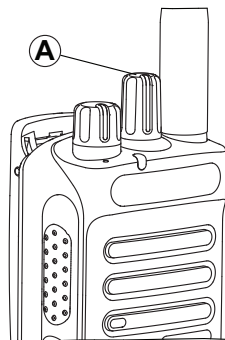

When switching from digital to analog mode, certain features are unavailable. Icons for the digital features (such as Messages) reflect this change by appearing 'grayed out'. Disabled features are hidden in the menu.

Your radio also has features available in both analog and digital mode. However, the minor differences in the way each feature works does **not** affect the performance of your radio.



Note:

Your radio also switches between digital and analog modes during a dual mode scan (see [Scan](#) on page 51).

IP Site Connect

This feature allows your radio to extend conventional communication beyond the reach of a single site, by connecting to different available sites which are connected via an Internet Protocol (IP) network.

When the radio moves out of range from one site and into the range of another, it connects to the new site's repeater to send or receive calls/data transmissions. Depending on your settings, this is done automatically or manually.

If the radio is set to do this automatically, it scans through all available sites when the signal from the current site is weak or when the radio is unable to detect any signal from the current site. It then locks on to the repeater with the strongest Received Signal Strength Indicator (RSSI) value.

In a manual site search, the radio searches for the next site in the roam list that is currently in range (but which may not have the strongest signal) and locks on to it.

**Note:**

Each channel can only have either Scan or Roam enabled, not both at the same time.

Channels with this feature enabled can be added to a particular roam list. The radio searches the channel(s) in the roam list during the automatic roam operation to locate the best site.

A roam list supports a maximum of 16 channels (including the Selected Channel).

**Note:**

You cannot manually add or delete an entry to the roam list. Check with your dealer or system administrator for more information.

Capacity Plus

Capacity Plus is a single-site trunking configuration of the MOTOTRBO radio system, which uses a pool of channels to support hundreds of users and up to 254 Groups. This feature allows your radio to efficiently utilize the available number of programmed channels while in Repeater Mode.

You hear a negative indicator tone if you try to access a feature not applicable to Capacity Plus via a programmable button press.

Your radio also has features that are available in conventional digital mode, IP Site Connect, Capacity Plus and Linked Capacity Plus. However, the minor

differences in the way each feature works does **not** affect the performance of your radio.

Check with your dealer or system administrator for more information on this configuration.

Linked Capacity Plus

Linked Capacity Plus is a multi-site multi-channel trunking configuration of the MOTOTRBO radio system, combining the best of both Capacity Plus and IP Site Connect configurations.

Linked Capacity Plus allows your radio to extend trunking communication beyond the reach of a single site, by connecting to different available sites which are connected via an Internet Protocol (IP) network. It also provides an increase in capacity by efficiently utilizing the combined available number of programmed channels supported by each of the available sites.

When the radio moves out of range from one site and into the range of another, it connects to the new site's repeater to send or receive calls/data transmissions. Depending on your settings, this is done automatically or manually.

If the radio is set to do this automatically, it scans through all available sites when the signal from the current site is weak or when the radio is unable to detect any signal from the current site. It then locks on to the repeater with the strongest Received Signal Strength Indicator (RSSI) value.

In a manual site search, the radio searches for the next site in the roam list that is currently in range (but which may not have the strongest signal) and locks on to it.

Any channel with Linked Capacity Plus enabled can be added to a particular roam list. The radio searches these channels during the automatic roam operation to locate the best site.



Note:

You cannot manually add or delete an entry to the roam list. Check with your dealer or system administrator for more information.

Similar to Capacity Plus, icons of features not applicable to Linked Capacity Plus are not available in the menu. You hear a negative indicator tone if you try to access a feature not applicable to Linked Capacity Plus via a programmable button press.

Check with your dealer or system administrator for more information on this configuration.











Identifying Status Indicators







Display Icons

The following are icons that appear on the display of the radio.

	<p>Received Signal Strength Indicator (RSSI)</p> <p>The number of bars displayed represents the radio signal strength. Four bars indicate the strongest signal. This icon is only displayed while receiving.</p>
	<p>Monitor</p> <p>Selected channel is being monitored.</p>
	<p>High Volume Data</p> <p>Radio is receiving high volume data and channel is busy.</p>
	<p>Notification</p>

	<p>Notification List has one or more missed events.</p> <p>Power Level</p> <p>Radio is set at Low power or Radio is set at High power.</p>
	<p>Tones Disable</p> <p>Tones are turned off.</p>
	<p>Over-the-Air Programming Delay Timer</p> <p>Indicates time left before automatic re-start of radio.</p>
	<p>Scan^{[3][4]}</p> <p>Scan feature is enabled.</p>
	<p>Scan- Priority 1^{[3][4]}</p> <p>Radio detects activity on channel/group designated as Priority 1.</p>

	Scan- Priority 2^{[3][4]} Radio detects activity on channel/group designated as Priority 2.
	Vote Scan Vote scan feature is enabled.
	Flexible Receive List Flexible receive list is enabled.
	Emergency Radio is in Emergency mode.
	Secure  The Privacy feature is enabled.
	Unsecure  The Privacy feature is disabled.
	Site Roaming^[3]  The site roaming feature is enabled.

	Talkaround^{[3][4]} In the absence of a repeater, radio is currently configured for direct radio to radio communication.
	Battery The number of bars (0 – 4) shown indicates the charge remaining in the battery. Blinks when the battery is low.
	Wi-Fi Excellent^[5] Wi-Fi signal is excellent.
	Wi-Fi Good^[5] Wi-Fi signal is good.
	Wi-Fi Average^[5] Wi-Fi signal is average.
	Wi-Fi Poor^[5] Wi-Fi signal is poor.

**Wi-Fi Unavailable^[5]**

Wi-Fi signal is unavailable.

**Group Call/All Call**

Indicates a Group Call or All Call in progress. In the Contacts list, it indicates a group alias (name) or ID (number).

**Phone Call as Private Call**

Indicates a Phone Call as Private Call in progress. In the Contacts list, it indicates a phone alias (name) or ID (number).

**Phone Call as Group Call**

Indicates a Phone Call as Group/All Call in progress. In the Contacts list, it indicates a phone alias (name) or ID (number).

Call Icons

The following icons appear on the radio's display during a call. These icons also appear in the Contacts list to indicate ID type.

**Private Call**

Indicates a Private Call in progress. In the Contacts list, it indicates a subscriber alias (name) or ID (number).



³ Not applicable in Capacity Plus

⁴ Not applicable in Linked Capacity Plus

⁵ Only applicable for XPR 3500e

Advanced Menu Icons



The following icons appear beside menu items that offer a choice between two options or as an indication that there is a sub-menu offering two options.

	Checkbox (Empty) Indicates the option is not selected.
	Checkbox (Checked) Indicates the option is selected.
	Solid Black Box Indicates the option selected for the menu item with a sub-menu.

Mini Notice Icons

The following icons appear momentarily on the radio's display after an action to perform task is taken.

	Successful Transmission (Positive)
---	---

	Successful action taken.
	Failed Transmission (Negative) Failed action taken.
	Transmission in Progress (Transitional) Transmitting. This is seen before indication for Successful Transmission or Failed Transmission.

Sent Item Icons

The following icons appear at the top right corner of the radio's display in the Sent Items folder.

LED Indicator

The LED indicator () shows the operational status of your radio.

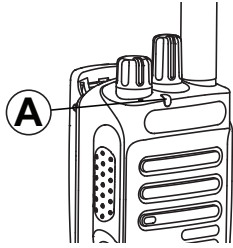

Blinking red

Battery mismatch occurs or radio is transmitting at low battery condition, receiving an emergency transmission or has failed the self-test upon powering up, or has moved out of range if radio is configured with Auto-Range Transponder System.

Solid yellow

Radio is monitoring a conventional channel. Also indicates fair battery charge when programmable button is pressed.

Blinking yellow

Radio is scanning for activity or receiving a Call Alert, flexible receive list is enabled or all local Linked Capacity Plus channels are busy.

Double blinking yellow

Radio is no longer connected to the repeater while in Capacity Plus or Linked Capacity Plus; all Capacity Plus or Linked Capacity Plus channels are currently busy.

Solid green

Radio is powering up or transmitting. Also indicates full charge of the battery when the programmable button is pressed.

Blinking green

Radio is powering up, receiving a non-privacy-enabled call or data, or detecting activity, or retrieving Over-the-Air Programming transmissions over the air.

Rapidly blinking green 

Radio is receiving a privacy-enabled call or data.







Note:

While in conventional mode, when the LED blinks green, it indicates the radio detects activity over the air. Due to the nature of the digital protocol, this activity may or may not affect the radio's programmed channel.





For Capacity Plus and Linked Capacity Plus, there is no LED indication when the radio is detecting activity over the air.

Alert Tones

Alert tones provide you with audible indications of the status, or response to data received on the radio.

<p>Continuous Tone</p> 	<p>A monotone sound. Sounds continuously until termination.</p>
<p>Periodic Tone</p> 	<p>Sounds periodically depending on the duration set by the radio. Tone starts, stops, and repeats itself.</p>
<p>Repetitive Tone</p> 	<p>A single tone that repeats itself until it is terminated by the user.</p>
<p>Momentary Tone</p> 	<p>Sounds only once for a short period of time defined by the radio.</p>

Indicator Tones





<p>High pitched tone</p> 	<p>Low pitched tone</p> 
	<p>Positive Indicator Tone</p>
	<p>Negative Indicator Tone</p>

Making and Receiving Calls

Selecting a Zone

A zone is a group of channels. Your radio supports up to 128 channels and 50 zones, with a maximum of 16 channels per zone.





- 1 Access the Zone feature.

Radio Controls	Steps
Programmed Zone button	Press the programmed Zone button.
Radio menu	<ol style="list-style-type: none"> 1  to access the menu. 2  or  to Zone and press  to select.

The current zone is displayed and indicated by a ✓.

- 2 Select the required zone.

Radio Control Steps

 or   or  and scroll to the required zone.

- 3 Press  to select.
The display shows <Zone> Selected momentarily and returns to the selected zone screen.

Selecting a Channel

Transmissions are sent and received on a channel. Depending on your radio's configuration, each channel may have been programmed differently to support different groups of users or supplied with different features. After selecting the relevant Zone, select the relevant channel you require to transmit or receive on.

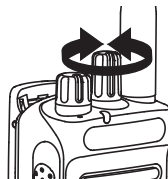

Once the required zone is displayed (if you have multiple zones in your radio), turn the programmed Channel Selector Knob to select the channel.

See [Privacy](#) on page 67 for more information. 

Receiving and Responding to a Radio Call

Once the channel, subscriber ID, or group ID is displayed, you can proceed to receive and respond to calls.

The LED lights up solid green while the radio is transmitting and blinks green when the radio is receiving.



Note:



The LED lights up solid green while the radio is transmitting and blinks green rapidly when the radio is receiving a privacy-enabled call and blinks green when receiving a non-privacy-enabled call.

To unscramble a privacy-enabled call, your radio must have the same Privacy Key, OR the same Key Value and Key ID (programmed by your dealer), as the transmitting radio (the radio you are receiving the call from).

Receiving and Responding to a Group Call

To receive a call from a group of users, your radio must be configured as part of that group.

When you receive a Group Call (while on the Home screen), the LED blinks green. The Group Call icon appears in the top right corner. The first text line shows the caller alias. The second text line displays the group call alias. Your radio unmutes and the incoming call sounds through the radio's speaker.

- 1 Hold the radio vertically 1 to 2 inches (2.5 to 5.0 cm) from your mouth.
 -  If the Channel Free Indication feature is enabled, you hear a short alert tone the moment the transmitting radio releases the **PTT** button, indicating the channel is free for you to respond. Press the **PTT** button to respond.
 -  If the Voice Interrupt feature is enabled, press the **PTT** button to stop the current call from the transmitting radio and free the channel for you to talk/respond.

The LED lights up solid green.

- 2 Wait for one of the following tones to finish (if enabled), and speak clearly into the microphone.
 - The Talk Permit Tone
 - The **PTT** Sidetone 
-

- 3 Release the **PTT** button to listen.
-

If there is no voice activity for a predetermined period of time, the call ends.



Note:

See [Making a Group Call](#) on page 38 for details on making a Group Call.

If the radio receives a Group Call while not on the Home screen, it remains on its current screen prior to answering the call.

Long press the  button to go to the Home screen to view the caller alias before replying.



Receiving and Responding to a Private Call

A Private Call is a call from an individual radio to another individual radio.

Depending on how your radio is programmed,

- The LED lights up solid yellow momentarily. Then, the LED blinks green.
- The LED blinks green.

The first text line shows private call icon. The second text line displays the private call alias. Your radio unmutes and the incoming call sounds through the speaker of the radio.

- 1 Hold the radio vertically 1 to 2 inches (2.5 to 5.0 cm) from your mouth.
 -  If the Channel Free Indication feature is enabled, you hear a short alert tone the moment the transmitting radio releases the **PTT** button, indicating the channel is free for you to respond. Press the **PTT** button to respond.
 -  If the Voice Interrupt feature is enabled, press the **PTT** button to stop the current call from the transmitting radio and free the channel for you to talk/respond.

The LED lights up solid green.

- 2 Wait for the Talk Permit Tone to finish (if enabled), and speak clearly into the microphone.
- 3 Release the **PTT** button to listen.

If there is no voice activity for a predetermined period of time, the call ends.

The display shows `Call Ended`.

See [Making a Private Call](#) on page 39 for details on making a Private Call.

Receiving an All Call

An All Call is a call from an individual radio to every radio on the channel. It is used to make important announcements requiring the user's full attention.

When you receive an All Call, a tone sounds and the LED blinks green.

The Group Call icon appears in the top right corner. The first text line shows the caller alias. The second text line displays `All Call`. Your radio unmutes and the incoming call sounds through the radio speaker.

Once the All Call ends, the radio returns to the previous screen before receiving the call. An All Call does not wait for a predetermined time before ending.

 If the Channel Free Indication feature is enabled, you hear a short alert tone the moment the transmitting radio releases the **PTT** button, indicating the channel is now available for use.

You cannot respond to an All Call.



Note:

See [Making an All Call](#) on page 40 for details on making an All Call.



Note:

The radio stops receiving the All Call if you switch to a different channel while receiving the call. During an All Call, you will **not** be able to use any programmed button functions until the call ends.

Receiving and Responding to a Selective Call

A Selective Call is a call from an individual radio to another individual radio. It is a Private Call on an analog system.

When you receive a Selective Call, the LED blinks green. The Private Call icon appears in the top right corner. The first text line shows the caller alias or `Selective Call` or `Alert with Call`. The first text line shows the Private Call icon. The radio displays

Selective Call or Alert with Call. Your radio unmutes and the incoming call sounds through the radio's speaker.

- 1 Hold the radio vertically 1 to 2 inches (2.5 to 5.0 cm) from your mouth.

- 2 Press the **PTT** button to respond to the call. The LED lights up solid green.

- 3 Wait for the Talk Permit Tone to finish (if enabled), and speak clearly into the microphone.

- 4 Release the **PTT** button to listen.

If there is no voice activity for a predetermined period of time, the call ends.



The display shows `Call Ended`.

See [Making a Private Call](#) on page 39 for details on making a Private Call.

Making a Radio Call

After selecting your channel, you can select a subscriber alias or ID, or group alias or ID by using:

- The Channel Selector Knob.

- A programmed **One Touch Access** button (see [Making a Phone Call with the One Touch Access Button](#)). 
- A programmable button – This method is for Phone Calls only (see [Making a Phone Call with the Programmable Phone Button](#)).
- The Contacts list (see [Contact Settings](#) on page 53). 



Note:

Your radio must have the Privacy feature enabled on the channel to send a privacy-enabled transmission. Only target radios with the same Privacy Key OR the same Key Value and Key ID as your radio will be able to unscramble the transmission.



Note:

See [Privacy](#) on page 67 for more information. 

Making a Group Call

To make a call to a group of users, your radio must be configured as part of that group.

- 1 Do one of the following.

- Select the channel with the active group alias or ID. See [Selecting a Channel](#) on page 34.
- Press the programmed **One Touch Access** button.

2 Hold the radio vertically 1 to 2 inches (2.5 to 5.0 cm) from your mouth.

3 Press the **PTT** button to make the call. The LED lights up solid green. The first text line shows the group call icon. The second text line shows the group call alias.

4 Release the **PTT** button to listen. When the target radio responds, the LED blinks green. You see the Group Call icon, the group alias or ID, and transmitting radio alias or ID on your display.

5  If the Channel Free Indication feature is enabled, you hear a short alert tone the moment the transmitting radio releases the **PTT** button, indicating the channel is free for you to respond. Press the **PTT** button to respond.

If there is no voice activity for a predetermined period of time, the call ends. Radio returns to the screen you were on prior to initiating the call.

Making a Private Call

While you can receive and/or respond to a Private Call initiated by an authorized individual radio, your radio must be programmed for you to initiate a Private Call.

There are two types of Private Calls. The first type, where a radio presence check is performed prior to setting up the call, while the other sets up the call immediately.

Only **one** of these call types can be programmed to your radio by your dealer.

You will hear a negative indicator tone, when you make a Private Call via the **One Touch Access** button, the programmed number keys, or the Channel Selector Knob, if this feature is not enabled.

1 Do one of the following.

- Select the channel with the active subscriber alias or ID. See [Selecting a Channel](#) on page 34.

- Press the programmed **One Touch Access** button.

2 Hold the radio vertically 1 to 2 inches (2.5 to 5.0 cm) from your mouth.

3 Press the **PTT** button to make the call. The LED lights up solid green. The first text line shows the private call icon. The second text line displays the private call alias.

4 Wait for the Talk Permit Tone to finish (if enabled), and speak clearly into the microphone.

5 Release the **PTT** button to listen. When the target radio responds, the LED blinks green.

6  If the Channel Free Indication feature is enabled, you hear a short alert tone the moment the transmitting radio releases the **PTT** button, indicating the channel is free for you to respond. Press the **PTT** button to respond.

If there is no voice activity for a predetermined period of time, the call ends. You hear a short tone. The display shows `Call Ended`.

You can also make a Private Call via Contacts (see [Making a Private Call from Contacts](#) on page 55).

Making an All Call

This feature allows you to transmit to all users on the channel. Your radio must be programmed to allow you to use this feature.

Users on the channel cannot respond to an All Call.

1 Select the channel with the active All Call group alias or ID. See [Selecting a Channel](#) on page 34.

2 Hold the radio vertically 1 to 2 inches (2.5 to 5.0 cm) from your mouth.

3 Press the **PTT** button to make the call. The LED lights up solid green. The first text line shows the All Call icon. The second text line displays the All Call alias.

4 Wait for one of the following tones to finish (if enabled), and speak clearly into the microphone.

- The Talk Permit Tone
 - The **PTT** Sidetone 
-

Making a Selective Call

Just like a Private Call, while you can receive and/or respond to a Selective Call initiated by an authorized individual radio, your radio must be programmed for you to initiate a Selective Call.

- 1 Select the channel with the active subscriber alias or ID. See [Selecting a Channel](#) on page 34.

- 2 Hold the radio vertically 1 to 2 inches (2.5 to 5.0 cm) from your mouth.

- 3 Press the **PTT** button to make the call. The LED lights up solid green. The Private Call icon appears in the top right corner. The first text line shows the subscriber alias. The second text line displays the call status.

- 4 Wait for one of the following tones to finish (if enabled), and speak clearly into the microphone.
 - The Talk Permit Tone
 - The **PTT** Sidetone 

- 5 Release the **PTT** button to listen. When the target radio responds, the LED blinks green.



 If the Channel Free Indication feature is enabled, you hear a short alert tone the moment the transmitting radio releases the **PTT** button, indicating the channel is free for you to respond. Press the **PTT** button to respond.

If there is no voice activity for a predetermined period of time, the call ends.

The display shows `Call Ended`.

Making a Radio Call

After selecting your channel, you can select a subscriber alias or ID, or group alias or ID by using:

- The Channel Selector Knob.
- A programmed **One Touch Access** button (see [Making a Phone Call with the One Touch Access Button](#)). 
- A programmable button – This method is for Phone Calls only (see [Making a Phone Call with the Programmable Phone Button](#)).
- The Contacts list (see [Contact Settings](#) on page 53). 

**Note:**

Your radio must have the Privacy feature enabled on the channel to send a privacy-enabled transmission. Only target radios with the same Privacy Key OR the same Key Value and Key ID as your radio will be able to unscramble the transmission.

**Note:**

See [Privacy](#) on page 67 for more information. 

Making a Group Call

To make a call to a group of users, your radio must be configured as part of that group.

- 1 Do one of the following.
 - Select the channel with the active group alias or ID. See [Selecting a Channel](#) on page 34.
 - Press the programmed **One Touch Access** button.

- 2 Hold the radio vertically 1 to 2 inches (2.5 to 5.0 cm) from your mouth.

- 3 Press the **PTT** button to make the call.

The LED lights up solid green. The first text line shows the group call icon. The second text line shows the group call alias.

- 4 Release the **PTT** button to listen.

When the target radio responds, the LED blinks green. You see the Group Call icon, the group alias or ID, and transmitting radio alias or ID on your display.

- 5  If the Channel Free Indication feature is enabled, you hear a short alert tone the moment the transmitting radio releases the **PTT** button, indicating the channel is free for you to respond. Press the **PTT** button to respond.

If there is no voice activity for a predetermined period of time, the call ends. Radio returns to the screen you were on prior to initiating the call.
-

Making a Private Call

While you can receive and/or respond to a Private Call initiated by an authorized individual radio, your radio must be programmed for you to initiate a Private Call.

There are two types of Private Calls. The first type, where a radio presence check is performed prior to setting up the call, while the other sets up the call immediately.

Only **one** of these call types can be programmed to your radio by your dealer.

You will hear a negative indicator tone, when you make a Private Call via the **One Touch Access** button, the programmed number keys, or the Channel Selector Knob, if this feature is not enabled.

- 1 Do one of the following.
 - Select the channel with the active subscriber alias or ID. See [Selecting a Channel](#) on page 34.
 - Press the programmed **One Touch Access** button.

-
- 2 Hold the radio vertically 1 to 2 inches (2.5 to 5.0 cm) from your mouth.

-
- 3 Press the **PTT** button to make the call. The LED lights up solid green. The first text line shows the private call icon. The second text line displays the private call alias.
-

- 4 Wait for the Talk Permit Tone to finish (if enabled), and speak clearly into the microphone.
-

- 5 Release the **PTT** button to listen. When the target radio responds, the LED blinks green.
-

- 6  If the Channel Free Indication feature is enabled, you hear a short alert tone the moment the transmitting radio releases the **PTT** button, indicating the channel is free for you to respond. Press the **PTT** button to respond.

If there is no voice activity for a predetermined period of time, the call ends. You hear a short tone. The display shows `Call Ended`.

You can also make a Private Call via Contacts (see [Making a Private Call from Contacts](#) on page 55).

Making an All Call

This feature allows you to transmit to all users on the channel. Your radio must be programmed to allow you to use this feature.

Users on the channel cannot respond to an All Call.

- 1 Select the channel with the active All Call group alias or ID. See [Selecting a Channel](#) on page 34.

- 2 Hold the radio vertically 1 to 2 inches (2.5 to 5.0 cm) from your mouth.

- 3 Press the **PTT** button to make the call. The LED lights up solid green. The first text line shows the All Call icon. The second text line displays the All Call alias.

- 4 Wait for one of the following tones to finish (if enabled), and speak clearly into the microphone.
 - The Talk Permit Tone
 - The **PTT** Sidetone 

Making a Selective Call

Just like a Private Call, while you can receive and/or respond to a Selective Call initiated by an authorized individual radio, your radio must be programmed for you to initiate a Selective Call.

- 1 Select the channel with the active subscriber alias or ID. See [Selecting a Channel](#) on page 34.

- 2 Hold the radio vertically 1 to 2 inches (2.5 to 5.0 cm) from your mouth.

- 3 Press the **PTT** button to make the call. The LED lights up solid green. The Private Call icon appears in the top right corner. The first text line shows the subscriber alias. The second text line displays the call status.

- 4 Wait for one of the following tones to finish (if enabled), and speak clearly into the microphone.
 - The Talk Permit Tone
 - The **PTT** Sidetone 

- 5 Release the **PTT** button to listen. When the target radio responds, the LED blinks green.
 -  If the Channel Free Indication feature is enabled, you hear a short alert tone the moment the transmitting radio releases the **PTT** button, indicating the channel is free for you to respond. Press the **PTT** button to respond.

If there is no voice activity for a predetermined period of time, the call ends.

The display shows `Call Ended`.

Stopping a Radio Call

This feature allows you to stop an ongoing Group or Private Call to free the channel for transmission. For example, when a radio experiences a “stuck microphone” condition where the **PTT** button is inadvertently pressed by the user.

Your radio must be programmed to allow you to use this feature.

- 1 Press the programmed **Transmit Interrupt Remote Dekey** button, while on the relevant channel.

The display shows `Remote Dekey`.

- 2 Wait for acknowledgement.

If successful, the radio sounds a positive indicator tone and the display shows `Remote Dekey Success`, indicating that the channel is now free.

If unsuccessful, the radio sounds a negative indicator tone and the display shows `Remote Dekey Failed`.

On the interrupted radio, the remote radio's display shows `Call Interrupted`, and the radio sounds a negative indicator tone until the **PTT** button is released.

Talkaround

You can continue to communicate when your repeater is not operating, or when your radio is out of the repeater's range but within talking range of other radios.

This is called “talkaround”.



Note:

This feature is not applicable in Capacity Plus and Linked Capacity Plus.

The Talkaround setting is retained even after powering down.



You can toggle between talkaround and repeater modes by pressing the programmed **Repeater/Talkaround** button or using the radio menu as described next.









Note:

This feature is not applicable in Citizens Band channels that are in the same frequency.

- 1  to access the menu.

- 2  or  to Utilities and press  to select.

- 3  or  to Radio Settings and press  to select.

- 4  or  to Talkaround and press  to select.
 You can also use or  to change the selected option.

- 5 Press  to enable/disable the Talkaround.
 The display shows ✓ beside Enabled.
 The ✓ disappears from beside Enabled.

Monitoring Features

Monitoring a Channel

Use the Monitor feature to make sure a channel is clear before transmitting.

This feature is not applicable in Capacity Plus and Linked Capacity Plus.

- 1 Press and hold the programmed **Monitor** button and listen for activity.

The Monitor icon appears on the display and the LED lights up solid yellow. You hear radio activity or total silence, depending on how your radio is programmed. This indicates that the channel is in use.

- 2  Wait until you hear “white noise”. This indicates that the channel is free.

- 3 Press the **PTT** button to talk and release it to listen.

Permanent Monitor

Use the Permanent Monitor feature to continuously monitor a selected channel for activity.

**Note:**

This feature is not applicable in Capacity Plus and Linked Capacity Plus.

- 1** Press the programmed **Permanent Monitor** button to activate permanent monitoring of the channel.
Radio sounds an alert tone, the LED lights up solid yellow, and the display shows Permanent Monitor On. The Monitor icon appears on the display.

 - 2** Press the programmed **Permanent Monitor** button to exit Permanent Monitor mode.
Radio sounds an alert tone, the LED turns off, and the display shows Permanent Monitor Off.
-

Advanced Features



Radio Check







If enabled, this feature allows you to determine if another radio is active in a system without disturbing the user of that radio. No audible or visual notification is shown on the target radio.

This feature is only applicable for subscriber aliases or IDs.

Sending a Radio Check

- 1 Access the Radio Check feature.

Radio Control	Steps
Programmed Radio Check button	<ol style="list-style-type: none"> 1 Press the programmed Radio Check button. 2  or  to the required subscriber alias or ID and press  to select.

Radio Control	Steps
Menu	<ol style="list-style-type: none"> 1  to access the menu. 2  or  to Contacts and press  to select. 3  or  to Radio Check and press  to select.

The display shows The LED lights up solid green.

- 2 Wait for acknowledgement.

If the  button is pressed when the radio is waiting for acknowledgement, a tone sounds, and the radio terminates all retries and exits Radio Check mode.

Radio returns to the subscriber alias or ID screen.

Scan Lists

Scan lists are created and assigned to individual channels/groups. Your radio scans for voice activity

by cycling through the channel/group sequence specified in the scan list for the current channel/group.

Your radio can support up to 250 scan lists, with a maximum of 16 members in a list. Each scan list supports a mixture of both analog and digital entries.

You can add, delete, or prioritize channels by editing a scan list.



Note:

This feature is not applicable in Capacity Plus and Linked Capacity Plus.

Viewing an Entry in the Scan List

- 1 to access the menu.

- 2 or to Scan and press to select.

- 3 or to and press to select.

- 4 Use or to view each member on the list.

The Priority icon appears left of the member's alias, if set, to indicate whether the member is on a Priority 1 or Priority 2 channel list. You **cannot** have multiple Priority 1 or Priority 2 channels in a scan list.

There is no Priority icon if priority is set to **None**.

Editing the Scan List

Adding a New Entry to the Scan List



- 1 to access the menu.

- 2 or to Scan and press to select.







- 3 or to and press to select.

- 4 or to Add Member and press to select.

- 5 or to the required alias or ID.

6  or  to the required priority level and press  to select.
The display shows , followed immediately by Add Another?.



7 Do one of the following:



-  or  to Yes and press  to select, and repeat Steps 5 to 6.
 -  or  to No and press  to save the current list.
-

Deleting an Entry from the Scan List



1  to access the menu.

2  or  to Scan and press  to select.







3  or  to and press  to select.

4  or  to the required alias or ID.

5 Press  to select.

6  or  to Delete and press  to select.

7 Do one of the following:



-  or  to Yes and press  to delete entry. The display shows positive mini notice.
 -  or  to No and press  to return to the previous screen.
-

8 Repeat Steps 4 to 6 to delete other entries.
After deleting all required aliases or IDs, long press  to return to the Home screen.



Setting and Editing Priority for an Entry in the Scan List



1  to access the menu.

2  or  to Scan and press  to select.

3  or  to and press  to select.

4 Press  to select.

5  or  to Edit Priority and press  to select.

6  or  to the required priority level and press  to select.
The display shows before returning to the previous screen.



Note:

The Priority icon appears left of the name of the member.

There is no Priority icon if priority is set to **None**.

Scan

When you start a scan, your radio cycles through the programmed scan list for the current channel looking for voice activity.

The LED blinks yellow.

There are two ways of initiating scan:

- **Main Channel Scan (Manual):** Your radio scans all the channels/groups in your scan list. On entering scan, your radio may (depending on the settings) automatically start on the last scanned “active” channel/group or on the channel where scan was initiated.
- **Auto Scan (Automatic):** Your radio automatically starts scanning when you select a channel/group that has Auto Scan enabled.





Note:



This feature is not applicable in Capacity Plus and Linked Capacity Plus.



Starting and Stopping Scan

1 Use the Channel Selector Knob to select a channel programmed with a scan list.

2  to access the menu.

3  or  to Scan and press  to select.

4  or  to Scan State and press  to select.

5  or  to required scan state and press  to select.

- The display shows `Scan On` when Scan is enabled. The LED blinks yellow and the scan icon appears.
- The display shows `Scan Off` if Scan is disabled. The LED turns off and the scan icon disappears.

Responding to a Transmission During a Scan

During scanning, your radio stops on a channel/group where activity is detected. The radio stays on that channel for a programmed time period known as “hang time”.

- 1 Hold the radio vertically 1 to 2 inches (2.5 to 5.0 cm) from your mouth.
 -  If the Channel Free Indication feature is enabled, you hear a short alert tone the moment

the transmitting radio releases the **PTT** button, indicating the channel is free for you to respond.

- 2 Press the **PTT** button during hang time. The LED lights up solid green.
- 3 Wait for one of the following tones to finish (if enabled), and speak clearly into the microphone.
 - The Talk Permit Tone
 - The **PTT** Sidetone 
- 4 Release the **PTT** button to listen. If you do not respond within the hang time, the radio returns to scanning other channels/groups.

Deleting a Nuisance Channel

If a channel continually generates unwanted calls or noise (termed a “nuisance” channel), you can temporarily remove the unwanted channel from the scan list.

This capability does not apply to the channel designated as the Selected Channel.

- 1 When your radio “locks on to” an unwanted or nuisance channel, press the programmed

Nuisance Channel Delete button until you hear a tone.

- 2 Release the **Nuisance Channel Delete** button. The nuisance channel is deleted.

Restoring a Nuisance Channel

To restore the deleted nuisance channel, do one of the following:

- Turn the radio off and then power it on again.
- Stop and restart a scan via the programmed **Scan** button or menu.
- Change the channel via the **Channel Selector Knob**.

Vote Scan

Vote Scan provides you with wide area coverage in areas where there are multiple base stations transmitting identical information on different analog channels.

Your radio scans analog channels of multiple base stations and performs a voting process to select the strongest received signal. Once that is established,

your radio unmutes to transmissions from that base station.

The LED blinks yellow and the vote scan icon appears on the status bar.

To respond to a transmission during a Vote Scan, follow the same procedures as [Responding to a Transmission During a Scan](#) on page 52.

Contact Settings

Contacts provides “address-book” capabilities on your radio. Each entry corresponds to an alias or ID that you use to initiate a call.

Each entry, depending on context, associates with one of five types of calls: Group Call, Private Call, All Call, PC Call or Dispatch Call.

PC Call and Dispatch Call are data-related. They are only available with the applications. Refer to the data applications documentation for more information.



Note:

If the Privacy feature is enabled on a channel, you can make privacy-enabled Group Call, Private Call, and All Call on that channel. Only

target radios with the same Privacy Key, or the same Key Value and Key ID as your radio will be able to unscramble the transmission.

See [Privacy](#) on page 67 for more information. 

Your radio supports two Contacts lists, one for Analog contacts and one for Digital contacts, with a maximum of 500 members for each Contacts list.

Each entry within Contacts displays the following information:

- Call Type
- Call Alias
- Call ID







Note:



You can add or edit subscriber IDs for the Digital Contacts list. Deleting subscriber IDs can only be performed by your dealer.

For the Analog Contacts list, you can only view the subscriber IDs, edit the subscriber IDs, and initiate a Call Alert. Adding and deleting capabilities can only be performed by your dealer.

Making a Group Call from Contacts

- 1  to access the menu.

- 2  or  to `Contacts` and press  to select.
The entries are alphabetically sorted.

- 3  or  to the required group alias or ID.

- 4 Hold the radio vertically 1 to 2 inches (2.5 to 5.0 cm) from your mouth.

- 5 Press the **PTT** button to make the call.
The LED lights up solid green.

- 6 Wait for one of the following tones to finish (if enabled), and speak clearly into the microphone.
 - The Talk Permit Tone
 - The **PTT** Sidetone 

- 7 Release the **PTT** button to listen.
When any user in the group responds, the LED blinks green. You see the Group Call icon, the group ID, and the user's ID on your display.

- 8  If the Channel Free Indication feature is enabled, you hear a short alert tone the moment the transmitting radio releases the **PTT** button, indicating the channel is free for you to respond. Press the **PTT** button to respond.

If there is no voice activity for a predetermined period of time, the call ends.

The LED lights up solid green. The display shows the destination alias.

- 6 Wait for the Talk Permit Tone to finish (if enabled), and speak clearly into the microphone.







- 7 Release the **PTT** button to listen. When the target radio responds, the LED blinks green and the display shows the transmitting user's ID.

- 8  If the Channel Free Indication feature is enabled, you hear a short alert tone the moment the transmitting radio releases the **PTT** button, indicating the channel is free for you to respond. Press the **PTT** button to respond.

If there is no voice activity for a predetermined period of time, the call ends.

The display shows `Call Ended`.



Making a Private Call from Contacts



- 1  to access the menu.
- 2  or  to `Contacts` and press  to select.
The entries are alphabetically sorted.
- 3  or  to the required subscriber alias or ID and press  to select.
- 4 Hold the radio vertically 1 to 2 inches (2.5 to 5.0 cm) from your mouth.
- 5 Press the **PTT** button to make the call.

Setting a Default Contact

- 1  to access the menu.



2  or  to `Contacts` and press  to select.



3  or  to the required alias or ID and press  to select.

4  or  to `Set as Default` and press  to select.



The radio sounds a positive indicator tone and the display shows positive mini notice.



A ✓ appears beside the selected default alias or ID.

2  or  to `Utilities` and press  to select.



3  or  to `Radio Settings` and press  to select.

4  or  to `Tones/Alert` and press  to select.

5  or  to `Call Ringers` and press  to select.

6  or  to `Call Alert` and press  to select.

The current tone is indicated by a ✓.

7  or  to the required tone and press  to select.

✓ appears beside selected tone.

Call Indicator Settings

Activating and Deactivating Call Ringers for Call Alert







You can select, or turn on or off ringing tones for a received Call Alert.



1  to access the menu.



Activating and Deactivating Call Ringers for Private Calls



You can turn on or off the ringing tones for a received Private Call.



- 1  to access the menu.

- 2  or  to Utilities and press  to select.

- 3  or  to Radio Settings and press  to select.

- 4  or  to Tones/Alerts and press  to select.



- 5  or  to Call Ringers and press  to select.



- 6  or  to Private Call and press  to select.



Activating and Deactivating Call Ringers for Selective Call



You can select, or turn on or off ringing tones for a received Selective Call.



- 1  to access the menu.

- 2  or  to Utilities and press  to select.



- 3  or  to Radio Settings and press  to select.

- 4  or  to Tones/Alert and press  to select.

- 5  or  to Call Ringers and press  to select.

- 6  or  to Selective Call and press  to select.











The current tone is indicated by a ✓.

- 7  or  to the required tone and press  to select.
✓ appears beside selected tone.
-



Assigning Ring Styles

You can program your radio to sound one of ten predefined ringing tones when receiving a Call Alert or a Text Message from a particular contact.

The radio sounds out each ring style as you navigate through the list.

- 1  to access the menu.
-
- 2  or  to `Contacts` and press  to select.
The entries are alphabetically sorted.
-
- 3  or  to the required alias or ID and press  to select.
-
- 4  or  to and press  to select.

A ✓ indicates the current selected tone.

- 5  or  to the required tone and press  to select.
The display shows `Contact Saved`.
-

Selecting a Ring Alert Type



Note:

The programmed **Ring Alert Type** button is assigned via CPS. Check with your dealer or system administrator to determine how your radio has been programmed.

You can program the radio calls to one predetermined vibrate call. If All Tones status is disabled, the radio displays the All Tone Mute icon.

If All Tones status is enabled, the related ring alert type is displayed.



The radio sounds one vibration if it is a momentary ring style. The radio vibrates repetitively if it is a repetitive ring style. When set to Ring and Vibrate, the radio sounds a specific ring tone if there is any incoming radio transaction (for example, Call Alert or Message). It sounds like a good key tone or missed call.

For radios with batteries that support the vibrate feature and are attached to a vibrating belt clip, the available Ring Alert Type options are Silent, Ring, Vibrate, and Ring and Vibrate.

For radios with batteries that do not support the vibrate feature and are not attached to a vibrating belt clip, Ring Alert Type is automatically set to Ring. The available Ring Alert Type options are Silent and Ring.



You can select a Ring Alert Type by performing one of the following actions.













- Press the programmed **Ring Alert Type** button to access the Ring Alert Type menu.

a) Press  or  to Ring, Vibrate, Ring & Vibrate or Silent and press  to select.

- Access this feature via the menu.

a) Press  to access the menu.

b) Press  or  to Utilities and press  to select.

- c) Press  or  to Radio Settings and press  to select.
- d) Press  or  to Tones/Alerts and press  to select.
- e) Press  or  to Ring Alert Type and press  to select.
- f) Press  or  to Ring, Vibrate, Ring & Vibrate or Silent and press  to select.

Configuring Vibrate Style





















Note:

The programmed **Vibrate Style** button is assigned via CPS. Check with your dealer or system administrator to determine how your radio has been programmed.

Vibrate Style is enabled when the Vibrating Belt Clip is attached to the radio with a battery that supports the vibrate feature.

You can configure the vibrate style by performing one of the following actions.

- Press the programmed **Vibrate Style** button to access the Vibrate Style menu.
 - a) Press  or  to Short, Medium, or Long and press  to select.

- Access this feature via the menu.
 - a) Press  to access the menu.
 - b) Press  or  to Utilities and press  to select.
 - c) Press  or  to Radio Settings and press  to select.
 - d) Press  or  to Tones/Alerts and press  to select.
 - e) Press  or  to Vibrate Style and press  to select.
 - f) Press  or  to Short, Medium, or Long and press  to select.

Escalating Alarm Tone Volume

You can program your radio to continually alert you when a radio call remains unanswered. This is done by automatically increasing the alarm tone volume over time. This feature is known as Escalart.

Call Log Features

Your radio keeps track of all recent outgoing, answered, and missed Private Calls. Use the call log feature to view and manage recent calls.



You can perform the following tasks in each of your call lists:



- Delete
- View Details



Viewing Recent Calls

The lists are Missed, Answered, and Outgoing.

- 1  to access the menu.



- 2  or  to Call Log and press  to select.



3  or  to preferred list and press  to select.
The display shows the most recent entry at the top of the list.



4  or  to view the list.
Press the **PTT** button to start a Private Call with the current selected alias or ID.



Deleting a Call from a Call List

1  to access the menu.





2  or  to Call Log and press  to select.

3  or  to the required list and press  to select.
When you select a call list and it contains no entries, the display shows *List Empty*.

4  or  to the required alias or ID and press  to select.



5  or  to Delete Entry? and press  to select.



6 Do one of the following:



- Press  to select Yes to delete the entry. The display shows *Entry Deleted*.
 -  or  to No, and press the  button to return to the previous screen.
-



Viewing Details from a Call List

1  to access the menu.

2  or  to Call Log and press  to select.

3  or  to the required list and press  to select.

4  or  to the required alias or ID and press  to select.

5  or  to `View Details` and press  to select.
Display shows details.

Call Alert Operation

Call Alert paging enables you to alert a specific radio user to call you back when they are able to do so.

This feature is applicable for subscriber aliases or IDs only and is accessible through the menu via `Contacts` or manual dial.

Receiving and Responding to a Call Alert

When you receive a Call Alert page, you see the notification list listing a Call Alert with the alias or ID of the calling radio on the display.



When you hear a repetitive tone and the LED blinks yellow, do one of the following:



- Press the **PTT** button while the display still shows the Call Alert in the Notification List to respond with a Private Call.
- Press  to exit the Notification List. The alert is moved to the Missed Call Log.

Making a Call Alert from the Contact List

1  to access the menu.

2  or  to `Contacts` and press  to select.

3  or  to the required subscriber alias or ID and press  to select.

4  or  to `Call Alert` and press  to select.

The display shows `Call Alert` and the subscriber alias or ID, indicating that the Call Alert has been sent.

The LED lights up solid green when your radio is sending the Call Alert.

If the Call Alert acknowledgement is received, the display shows positive mini notice.

If the Call Alert acknowledgement is not received, the display shows negative mini notice.

Making a Call Alert with the One Touch Access Button

Press the programmed **One Touch Access** button to make a Call Alert to the predefined alias or ID.

The display shows `Call Alert` and the subscriber alias or ID, indicating that the Call Alert has been sent.

The LED lights up solid green when your radio is sending the Call Alert.

If the Call Alert acknowledgement is received, the display shows positive mini notice.

If the Call Alert acknowledgement is not received, the display shows negative mini notice.

Emergency Operation

An Emergency Alarm is used to indicate a critical situation. You are able to initiate an Emergency at

any time on any screen display even when there is activity on the current channel.

Your dealer can set the duration of a button press for the programmed **Emergency** button, except for long press, which is similar with all other buttons:

Short press Between 0.05 seconds and 0.75 seconds.

Long press Between 1.00 second and 3.75 seconds.

The **Emergency** button is assigned with the Emergency On/Off feature. Check with your dealer for the assigned operation of the **Emergency** button.



Note:

If the short press for the **Emergency** button is assigned to turn on the Emergency mode, then the long press for the **Emergency** button is assigned to exit the Emergency mode.

If the long press for the **Emergency** button is assigned to turn on the Emergency mode, then the short press for the **Emergency** button is assigned to exit the Emergency mode.

Your radio supports **three** Emergency Alarms:

- Emergency Alarm
- Emergency Alarm with Call
- Emergency Alarm with Voice to Follow 

**Note:**

Only one of the Emergency Alarms above can be assigned to the programmed **Emergency** button.

In addition, each alarm has the following types:

- **Regular** – Radio transmits an alarm signal and shows audio and/or visual indicators.
- **Silent** – Radio transmits an alarm signal without any audio or visual indicators. Radio receives calls without any sound through the radio's speaker, until you press the **PTT** button to initiate the call.
- **Silent with Voice** – Radio transmits an alarm signal without any audio or visual indicators, but allow incoming calls to sound through the radio's speaker.

Sending an Emergency Alarm

This feature allows you to send an Emergency Alarm, a non-voice signal, which triggers an alert indication on a group of radios.

If your radio is set to Silent, it does not display any audio or visual indicators during Emergency mode.

Press the programmed **Emergency On** button.

The display shows one of the following:

- Tx Alarm and the destination alias.
- Tx Telegram and the destination alias.

The LED lights up solid green and the Emergency icon appears on the Home screen display.

When an Emergency Alarm acknowledgement is received, the Emergency tone sounds and the LED blinks green. The display shows `Alarm Sent`.

If your radio does not receive an Emergency Alarm acknowledgement, and after all retries have been exhausted, a tone sounds and the display shows `Alarm Failed`.

Radio exits the Emergency Alarm mode and returns to the Home screen.

Sending an Emergency Alarm with Call

This feature allows you to send an Emergency Alarm to a group of radios. Upon acknowledgement by a radio within the group, the group of radios can

communicate over a programmed Emergency channel.

If your radio is set to Silent, it does not display any audio or visual indicators during Emergency mode, or allow any received calls to sound through the speaker of the radio, until you press the **PTT** button to initiate the call.

If your radio is set to Silent with Voice, it does not display any audio or visual indicators during Emergency mode, but allow incoming calls to sound through the speaker of the radio. The indicators only appear once you press the **PTT** button to initiate, or respond to, the call.

1 Press the programmed **Emergency On** button.

The display shows one of the following:

- Tx Alarm and the destination alias.
- Tx Telegram and the destination alias.

When an Emergency Alarm acknowledgement is received, the Emergency tone sounds and the LED blinks green. The display shows Alarm Sent. Your radio enters the emergency call mode when the display shows Emergency and the destination group alias.

2 Hold the radio vertically 1 to 2 inches (2.5 to 5.0 cm) from your mouth.

3 Press **PTT** button to make the call. The LED lights up solid green and the Group icon appears on the display.

4 Wait for one of the following tones to finish (if enabled), and speak clearly into the microphone.

- The Talk Permit Tone
- The **PTT** Sidetone 

5 Release the **PTT** button to listen.

 If the Channel Free Indication feature is enabled, you hear a short alert tone the moment the transmitting radio releases the **PTT** button, indicating the channel is free for you to respond.

6 Press the **PTT** button to respond.

7 Once your call ends, press **Emergency Off** button to exit the Emergency mode.

Sending an Emergency Alarm with Voice

This feature allows you to send an Emergency Alarm to a group of radios. The microphone of your radio is

automatically activated, allowing you to communicate with the group of radios without pressing the **PTT** button.

This activated microphone state is also known as “hot mic”.

If your radio has Emergency Cycle Mode enabled, repetitions of hot mic and receiving period are made for a programmed duration. During Emergency Cycle Mode, received calls sound through the speaker of the radio.

If you press the **PTT** button during the programmed hot mic transmission or programmed receiving period, regardless whether Emergency Cycle Mode is enabled or disabled, you hear a prohibit tone, indicating that you should release the **PTT** button. The radio ignores the **PTT** press and remains in Emergency mode.

**Note:**

If you press the **PTT** button during hot mic, and continue to press it after the hot mic duration expires, the radio continues to transmit until you release the **PTT** button.

If your radio is set to Silent, it does not display any audio or visual indicators during Emergency mode, or

allow any received calls to sound through the speaker of the radio, until the programmed hot mic transmission period is over, and you press the **PTT** button.

If your radio is set to Silent with Voice, it does not display any audio or visual indicators during Emergency mode when you are making the call with hot mic, but allow sound through the speaker of the radio when the target radio responds after the programmed hot mic transmission period is over. The indicators only appear when you press the **PTT** button.

**Note:**

If the Emergency Alarm request fails, the radio does not retry to send the request, and enters the hot mic state directly.

1 Press the programmed **Emergency On** button.

The display shows one of the following:

- Tx Alarm and the destination alias.
- Tx Telegram and the destination alias.

The LED lights up solid green and the Emergency icon is displayed.

- 2 Once the display shows **Alarm Sent**, speak clearly into the microphone.

When hot mic has been enabled, the radio automatically transmits without a **PTT** button press until the hot mic duration expires. While transmitting, the LED lights up solid green and the Emergency icon appears on the display.

- 3 The radio automatically stops transmitting when the cycling duration between hot mic and receiving calls expires, if Emergency Cycle Mode is enabled.

- 4 Once the hot mic duration expires, the radio automatically stops transmitting. To transmit again, press the **PTT** button.

Reinitiating an Emergency Mode



Note:

This feature is only applicable to the radio sending the Emergency Alarm.

There are two instances where this can happen:

- You change the channel while the radio is in Emergency mode. This exits the Emergency

mode. If Emergency Alarm is enabled on this new channel, the radio reinitiates Emergency.

- You press the programmed **Emergency On** button during an Emergency initiation/transmission state. This causes the radio to exit this state, and to reinitiate Emergency.

Exiting Emergency Mode After Sending the Emergency Alarm

Your radio exits Emergency mode when one of the following occurs:

- Emergency Alarm acknowledgement is received (for **Emergency Alarm** only).
- All retries to send the alarm have been exhausted.
- The **Emergency Off** button is pressed.



Note:

If your radio is powered off, it exits the Emergency mode. The radio will not reinitiate the Emergency mode automatically when it is turned on again.

Privacy

If enabled, this feature helps to prevent eavesdropping by unauthorized users on a channel

by the use of a software-based scrambling solution. The signaling and user identification portions of a transmission are not scrambled.

Your radio must have privacy enabled on the channel to send a privacy-enabled transmission, although this is not a necessary requirement for receiving a transmission. While on a privacy-enabled channel, the radio is still able to receive clear (unscrambled) transmissions.

Your radio supports two types of privacy:

- Basic Privacy.
- Enhanced Privacy.

Only one of the privacy types above can be assigned to the radio.

To unscramble a privacy-enabled call or data transmission, your radio must be programmed to have the same Privacy Key (for Basic Privacy), or the same Key Value and Key ID (for Enhanced Privacy) as the transmitting radio.

If your radio receives a scrambled call that is of a different Privacy Key, or a different Key Value and Key ID, you will either hear a garbled transmission (Basic Privacy) or nothing at all (Enhanced Privacy).

**Note:**

This feature is not applicable in Citizens Band channels that are in the same frequency.

If the radio has a privacy type assigned, the Home screen shows the Secure or Unsecure icon, except when the radio is sending or receiving an Emergency call or alarm.

The LED lights up solid green while the radio is transmitting and blinks green rapidly when the radio is receiving an ongoing privacy-enabled transmission.

You can access this feature by performing one of the following actions:



- Pressing the programmed **Privacy** button to toggle privacy on or off.
- Using the Radio Menu as described by the steps described next.



**Note:**



Some radio models may not offer this Privacy feature. Check with your dealer or system administrator for more information.

1

to access the menu.

2  or  to `Utilities` and press  to select.

3  or  to `Radio Settings` and press  to select.

4  or  to `Privacy` and press  to select.

You can also use  or  to change selected option.

5 Press  to enable/disable `Privacy`.

The display shows ✓ beside `Enabled`.

The ✓ disappears from beside `Enabled`.

Security

You can enable or disable any radio in the system. For example, you might want to disable a stolen radio, to prevent the thief from using it, and enable that radio, when it is recovered.









Note:

Performing `Radio Disable` and `Enable` is limited to radios with these functions enabled. Check with your dealer or system administrator for more information.

Radio Disable



1 Access this feature by

Radio Controls	Steps
Radio Disable button	<ol style="list-style-type: none"> 1 Press the programmed Radio Disable button. 2  or  to the required alias or ID and press  to select.
Radio menu	<ol style="list-style-type: none"> 1  to access the menu. 2  or  to <code>Contacts</code> and press  to select. The entries are alphabetically sorted.

Radio Controls



3 Use one of the steps described next to select the required subscriber alias or ID:



- Select the required alias or ID directly.

-  or  to the required alias or ID and press

-  to select.

- Use the Manual Dial menu.



-  or  to Manual Dial and press  to select.

-  or  to Radio Number and press  to select.

Radio Controls

- The first line of the display shows Radio Number: . The second line of the display shows a blinking cursor. Use the keypad to enter the subscriber alias or ID and press

- .

4  or  to Radio Disable and press  to select.

The display shows Radio Enable: <Subscriber Alias or ID> and the LED lights up solid green.

2 Wait for acknowledgement.







If successful, the radio sounds a positive indicator tone and the display shows positive mini notice.

If not successful, the radio sounds a negative indicator tone and the display shows negative mini notice.









Do not press  during the Radio Disable operation as you will not get an acknowledgement message.

Radio Enable





1 Access this feature by

Radio Controls	Steps
Radio Enable button	<ol style="list-style-type: none"> 1 Press the programmed Radio Enable button. 2  or  to the required alias or ID and press  to select.
Radio menu	<ol style="list-style-type: none"> 1  to access the menu. 2  or  to Contacts and press  to select. The entries are alphabetically sorted.

Radio Controls

- 3 Use one of the steps described next to select the required subscriber alias or ID
 - Select the required alias or ID directly.
 -  or  to the required alias or ID and press  to select.
 - Use the Manual Dial menu.
 -  or  to Manual Dial and press  to select.
 -  or  to Radio Number and press  to select.

Radio Controls

- The first line of the display shows Radio Number: . The second line of the display shows a blinking cursor. Use the keypad to enter the subscriber alias or ID and press  .
- 4  or  to Radio Enable and press  to select.

The display shows Radio Enable: <Subscriber Alias or ID> and the LED lights up solid green.

2 Wait for acknowledgement.

If successful, the radio sounds a positive indicator tone and the display shows positive mini notice.

If not successful, the radio sounds a negative indicator tone and the display shows negative mini notice.

Do not press  during the Radio Enable operation as you will not get an acknowledgement message.

Lone Worker

This feature raises an emergency if there is no user activity, such as any radio button press or activation of the channel selector, for a predefined time.

Before raising the emergency, when the inactivity timer expires, the radio warns the user via an audio indicator.

If there is still no acknowledgement by the user before the predefined reminder timer expires, the radio initiates an Emergency Alarm.

Only one of the following Emergency Alarms can be assigned to this feature:

- Emergency Alarm
- Emergency Alarm with Call
- Emergency Alarm with Voice to Follow 

The radio remains in the emergency state allowing voice messages to proceed until action is taken. See

[Emergency Operation](#) on page 63 on ways to exit Emergency.





Note:



This feature is limited to radios with this function enabled. Check with your dealer or system administrator for more information.

Password Lock Features

If enabled, this feature only allows you access your radio if the correct password is entered upon powering up.

Accessing the Radio from Password

- 1 Power up your radio.
You hear a continuous tone.
-
- 2 Enter your current four-digit password. Press or to edit each digit's numeric value. Each digit changes to ●. Press to move to next digit. Press  to confirm your selection.
 - Enter your current four-digit password with the radio's keypad. The second line of the display shows ●●●●. Press  to proceed.

- Enter your current four-digit password. Press  or  to edit each digit's numeric value. Each digit changes to ●. Press to move to next digit. Press  to confirm your selection.

You hear a positive indicator tone for every digit entered. Press to remove the last digit on the display.

If the password is correct, your radio proceeds to power up. See [Powering Up the Radio](#) on page 17.

If the password is incorrect, the display shows Wrong Password. Repeat Steps 1 and 2.

After the third incorrect password, the display shows Wrong Password and then, shows Radio Locked. A tone sounds and the LED double blinks yellow.

Your radio enters into locked state for 15 minutes, and responds to inputs from **On/Off/Volume Control Knob** only.





**Note:**



The radio is unable to receive any call, including emergency calls, in locked state.

Unlocking the Radio from Locked State

- 1 If your radio was powered down after being in the locked state, power up the radio.
A tone sounds and the LED double blinks yellow.
The display shows `Radio Locked`.
- 2 Wait for 15 minutes.
Your radio restarts the 15 minutes timer for locked state when you power up.
- 3 Repeat Steps 1 and 2 in [Accessing the Radio from Password](#) on page 73.

Turning the Password Lock On or Off

- 1  to access the menu.
- 2  or  to `Utilities` and press  to select.

- 3  or  to `Radio Settings` and press  to select.

- 4  or  to `Passwd Lock` and press  to select.

- 5 Enter the four-digit password.
See Step 2 in [Accessing the Radio from Password](#) on page 73.

- 6 Press  to proceed.

If the password is incorrect, the display shows `Wrong Password`, and automatically returns to the previous menu.



- 7 If the password entered in the previous step is correct, press  to enable/disable password lock.



The display shows ✓ beside `Enabled`.



The ✓ disappears from beside `Enabled`.

Changing the Password

- 1  to access the menu.



- 2  or  to Utilities and press  to select.

- 3  or  to Radio Settings and press  to select.

- 4  or  to Passwd Lock and press  to select.

- 5 Enter the four-digit password.
See Step 2 in [Accessing the Radio from Password](#) on page 73.

- 6 Press  to proceed.
If the password is incorrect, the display shows Wrong Password, and automatically returns to the previous menu.

- 7 If the password entered in the previous step is correct,  or  to Change Pwd and press  to select.

- 8 Enter a new four-digit password.
See Step 2 in [Accessing the Radio from Password](#) on page 73.

- 9 Reenter the previously entered four-digit password. See Step 2 in [Accessing the Radio from Password](#) on page 73.

- 10 Press  to proceed.
If the reentered password matches the new password entered earlier, the display shows Password Changed.

If the reentered password does **NOT** match the new password entered earlier, the display shows Passwords Do Not Match.

The screen automatically returns to the previous menu.

Notification List

Your radio has a Notification List that collects all your “unread” events on the channel, such as unread text messages, missed calls, and call alerts.

The Notification icon appears on the status bar when the Notification List has one or more events.

The list supports a maximum of forty (40) unread events. When it is full, the next event automatically replaces the oldest event.



Note:

After the events are read, they are removed from the Notification List.

Accessing the Notification List

- 1 to access the menu.

- 2 or to Notification and press to select.

- 3 or to the required event and press to select.

Long press to return to the Home Screen.

Auto-Range Transponder System (ARTS)

ARTS is an analog-only feature designed to inform you when your radio is out-of-range of other ARTS-equipped radios.

ARTS-equipped radios transmit or receive signals periodically to confirm that they are within range of each other. Your dealer can program your radio to transmit or receive the ARTS signal.

Your radio provides indications of states as follows:

- **First-Time Alert** – A tone sounds and the display shows `In Range` after the channel alias.
- **ARTS-in-Range Alert** – A tone sounds, if programmed, and the display shows `In Range` after the channel alias.
- **ARTS-Out-of-Range Alert** – A tone sounds, the LED rapidly blinks red, and the display alternates between `Out of Range` and the home screen.

Over-the-Air-Programming (OTAP)

Your radio can be updated by your dealer remotely, via OTAP, without needing to be physically

connected. Additionally, some settings can also be configured via OTAP.

While undergoing OTAP, the LED blinks green.



Note:

When the radio is receiving high volume data, the High Volume Data icon appears and channel is busy. A **PTT** button press at this time may cause a negative tone to sound.

Once the programming is complete, depending on your radio's configuration:

- A tone sounds, the display shows `Updating`
`Restarting`, and your radio restarts (powers off and on again).
- Select between `Restart Now` or `Postpone`. Selecting `Postpone` allows your radio to return to the previous display, with an OTAP Timer icon visible, for a period of time before the automatic restart occurs.

Upon power up after the automatic restart occurs, the display shows `Sw Update Completed` if the OTAP update is successful or `Sw Update Failed` if the OTAP update is unsuccessful.

See [Software Update](#) on page 93 for your updated software version.

Wi-Fi Operation

Wi-Fi® is a registered trademark of Wi-Fi Alliance®.



Note:

This feature is applicable to XPR 3500e only.

This feature allows you to setup and connect to a Wi-Fi® network. Wi-Fi supports updates of radio firmware, codeplug, and resources such as language packs and voice announcement.

Turning Wi-Fi On or Off









Note:

This feature is applicable to XPR 3500e only. The programmed **Wi-Fi On or Off** button is assigned via CPS. Check with your dealer or system administrator to determine how your radio has been programmed.

You can turn on or turn off Wi-Fi® by performing one of the following actions.

- Press the programmed **Wi-Fi On or Off** button. Voice Announcement sounds Turning On Wi-Fi or Turning Off Wi-Fi.

-
- Access this feature via the menu.
 - a) Press  to access the menu.
 - b) Press  or  to WiFi and press  to select.
 - c) Press  or  to Turn On and press  to select.
The radio displays Turning On WiFi.
-

Connecting to a Network Access Point



Note:
This feature is applicable to XPR 3500e only.









When you turn on Wi-Fi®, the radio scans and connects to a network access point.

Viewing Details of Network Access Points



Note:
This feature is applicable to XPR 3500e only.

Perform the following actions to view details of network access points.

- 1 Press  to access the menu.
-
- 2 Press  or  to WiFi and press  to select.
-
- 3 Press  or  to a network access point and press  to select.
-
- 4 Press  or  to view Network SSID, Security Mode, IP Address, and MAC Address.
For a non-connected network access point, only the Service Set Identifier (SSID) and Security Mode are displayed.
-

Utilities

Setting the Squelch Level

You can adjust your radio's squelch level to filter out unwanted calls with low signal strength or channels that have a higher than normal background noise.

Normal is the default. Tight filters out (unwanted) calls and/or background noise; however, calls from remote locations may also be filtered out.









Note:



This feature is not applicable in Citizens Band channels that are in the same frequency.



Press the programmed **Squelch** button to toggle squelch level between normal and tight. Follow the procedure described next to access this feature via the radio's menus.

- 1  to access the menu.

- 2  or  to Utilities and press  to select.

- 3  or  to Radio Settings and press  to select.

- 4  or  to Squelch and press  to select.
The display shows Tight and Normal.

- 5  or  to the required setting and press  to select.
✓ appears besides selected setting. Screen returns to the previous menu.

Setting the Power Level



Note:



This feature is not applicable in Citizens Band channels that are in the same frequency.



You can customize the power setting of the radio to high or low for each channel.



High enables communication with radios located at a considerable distance from you. Low enables communication with radios in closer proximity.



Press the programmed **Power Level** button to toggle transmit power level between high and low. Follow the procedure described next to access this feature via the radio menu.

- 1 Press  to access the menu.

2 Press  or  to **Utilities** and press  to select.

3 Press  or  to **Radio Settings** and press  to select.

4 Press  or  to **Power** and press  to select.

5 Press  or  to the required setting and press  to select.

✓ appears beside selected setting. At any time, long press  to return to the Home screen. Screen returns to the previous menu.

Adjusting the Display Brightness











You can adjust the display brightness of the radio as needed.



Note:

Display brightness cannot be adjusted when Auto Brightness is enabled.

Adjust the Display Brightness by performing one of the following actions:

Radio Control	Steps
Programmed Display Brightness Button	<ol style="list-style-type: none"> 1 Press the programmed Brightness button. 2 Decrease display brightness by pressing or increase the display brightness by pressing . Select from setting of 1 to 8. Press  to confirm your entry.
Menu	<ol style="list-style-type: none"> 1  to access the menu. 2  or  to Utilities and press  to select. 3  or  to Radio Settings and press  to select. 4  or  to Brightness and press  to select.

Radio Control	Steps
	<p>The display shows a progress bar.</p> <p>5 Decrease display brightness by pressing or increase the display brightness by pressing . Select</p> <p>from setting of 1 to 8. Press  to confirm your entry.</p>

Turning the Voice Operating Transmission (VOX) Feature On or Off

This feature allows you to initiate a hands-free voice activated call on a programmed channel. The radio automatically transmits, for a programmed period, whenever the microphone on the VOX-capable accessory detects voice.



Note:

This feature is not applicable in Citizens Band channels that are in the same frequency.

Pressing the **PTT** button during radio operation will disable VOX. To re-enable VOX, do one of the following:

- Turn the radio off and power it on again.
- Change the channel via the Channel Selector Knob.
- Press the programmed **VOX** button to toggle the feature on or off.
- Follow the steps described next to access this feature via the radio menu.

If the Talk Permit Tone feature is enabled (see [Turning the Talk Permit Tone On or Off](#) on page 84), use a trigger word to initiate the call. Wait for the Talk Permit Tone to finish before speaking clearly into the microphone.



Note:

Turning this feature on or off is limited to radios with this function enabled. Check with your dealer or system administrator for more information.

1









to access the menu.

2



to **Utilities** and press  to select.

3  or  to Radio Settings and press  to select.

4  or  to VOX and press  to select.

5 Press  to disable/enable VOX.

The display shows ✓ beside Enabled.

The ✓ disappears from beside Enabled.



Setting the Display Backlight Timer



You can set the the radio's display backlight timer as needed. The setting also affects the Menu Navigation Buttons and keypad backlighting accordingly.



Press the programmed **Backlight** button to toggle the backlight settings, or follow the procedure described next to access this feature via the radio menu.



The display backlight and keypad backlighting are automatically turned off if the LED indicator is disabled (see [Turning the LED Indicator On or Off](#) on page 85).

1  to access the menu.

2  or  to Utilities and press  to select.

3  or  to Radio Settings and press  to select.

4  or  to Display and press  to select.



5  or  to Backlight Timer and press  to select.



Turning the Radio Tones/Alerts On or Off



You can enable and disable all radio tones and alerts (except for the incoming Emergency alert tone) if needed.





Press the programmed **All Tones/Alerts** button to toggle all tones on or off, or follow the procedure described next to access this feature via the radio menu.

- 1  to access the menu.

- 2  or  to Utilities and press  to select.

- 3  or  to Radio Settings and press  to select.

- 4  or  to Tones/Alerts and press  to select.



- 5  or  to All Tones and press  to select.
 You can also use  or  to change the selected option.



- 6 Press  to enable/disable all tones and alerts.
 The display shows ✓ beside Enabled.
 The ✓ disappears from beside Enabled.



Turning the Power Up Alert Tone On or Off





You can enable and disable the Power Up Alert Tone if needed.

- 1  to access the menu.

- 2  or  to Utilities and press  to select.

- 3  or  to Radio Settings and press  to select.

- 4  or  to Tones/Alerts and press  to select.

- 5  or  to Power Up and press  to select.
 You can also use  or  to change the selected option.

- 6 Press  to enable/disable the Power Up Alert Tone.



The display shows ✓ beside Enabled.



The ✓ disappears from beside Enabled.

Setting the Tone Alert Volume Offset Level



You can adjust the Tone Alert Volume Offset level if needed. This feature adjusts the volume of the tones/alerts, allowing it to be higher or lower than the voice volume.



1  to access the menu.

2  or  to Utilities and press  to select.



3  or  to Radio Settings and press  to select.

4  or  to Tones/Alerts and press  to select.

5  or  to Vol. Offset and press  to select.

6  or  to the required volume value. The radio sounds a feedback tone with each corresponding volume value.



7 Do one of the following:



- Press  to keep the required displayed volume value.
- Press  to exit without changing the current volume offset settings.
- Repeat Step 6 to select another volume value.

Turning the Talk Permit Tone On or Off



You can enable and disable the Talk Permit Tone if needed.

1  to access the menu.

2  or  to Utilities and press  to select.

3  or  to Radio Settings and press  to select.

4  or  to Tones/Alerts and press  to select.



5  or  to Talk Permit and press  to select.



6 Press  to enable/disable the Talk Permit Tone.
The display shows ✓ beside Enabled.
The ✓ disappears from beside Enabled.

Language

You can set your radio display to be in your required language.



1  to access the menu.

2  or  to Utilities and press  to select.

3  or  to Radio Settings and press  to select.

4  or  to Languages and press  to select.



You can also use  or  to change selected option.



5  or  to the required language and press  to enable. ✓ appears beside selected language.



Turning the LED Indicator On or Off



You can enable and disable the LED Indicator if needed.

1  to access the menu.

2  or  to Utilities and press  to select.

3  or  to Radio Settings and press  to select.

- 4  or  to LED Indicator and press  to select.

You can also use  or  to change the selected option.

- 5 Press  to enable/disable the LED Indicator.



The display shows ✓ beside Enabled.



The ✓ disappears from beside Enabled.



Turning the Introduction Screen On or Off



You can enable and disable the Introduction Screen if needed.



- 1  to access the menu.

- 2  or  to Utilities and press  to select.

- 3  or  to Radio Settings and press  to select.

- 4  or  to Display and press  to select.

- 5  or  to Intro Screen and press  to select.

You can also use  or  to change the selected option.

- 6 Press  to enable/disable the Introduction Screen.

The display shows ✓ beside Enabled.

The ✓ disappears from beside Enabled.

Turning the Voice Announcement On or Off









Note:

The Voice Announcement feature can only be enabled via the MOTOTRBO CPS. If enabled, the Text-to-Speech feature is automatically disabled, and vice versa.

This feature enables the radio to audibly indicate the current Zone or Channel the user has assigned, or programmable button press. This audio indicator can



be customized per customer requirements. This is typically useful when the user is in a difficult condition to read the content shown on the display.

Toggle Voice Announcement On or Off.

Radio Control	Steps
Programmed Voice Announcement Button	Press the programmed Voice Announcement button.
Menu	<ol style="list-style-type: none"> 1  to access the menu. 2  or  to Utilities and press  to select. 3  or  to Radio Settings and press  to select.



Radio Control



Steps

- 4  or  to Voice Announcement and press  to select.



Note:



You can also use  or  to change the selected option.



- 5 Do one of the following:
 - Press  to enable Voice Announcement. The display shows ✓ beside Enabled.
 - Press  to disable Voice Announcement. The ✓ disappears from beside Enabled.



Call Forwarding

You can enable your radio to automatically forward voice calls to another radio.



1  to access the menu.

2  or  to Utilities and press  to select.

3  or  to Call Forward and press  to select.

You can also use  or  to change the selected option.



4 Do one of the following:



- Press  to enable Call Forwarding. The display shows ✓ beside Enabled.
 - Press  to disable Call Forwarding. The ✓ disappears from beside Enabled.
-

Menu Timer



Set the period of time your radio stays in the menu before it automatically switches to the Home screen.



1  to access the menu.

2  or  to Utilities and press  to select.

3  or  to Radio Settings and press  to select.

4  or  to Display and press  to select.



5  or  to Menu Timer and press  to select.



6  or  to the required setting and press  to select.



Analog Mic AGC (Mic AGC-A)



This feature controls the your radio's microphone gain automatically while transmitting on an analog system. It suppresses loud audio or boosts soft audio to a preset value in order to provide a consistent level of audio.

1  to access the menu.



2  or  to Utilities and press  to select.

3  or  to Radio Settings and press  to select.

You can also use  or  to change the selected option.

4  or  to Analog Mic AGC and press  to select.



5 Do one of the following:



- Press  to enable Analog Mic AGC. The display shows ✓ beside Enabled.
 - Press  to disable Analog Mic AGC. The ✓ disappears from beside Enabled.
-

Digital Mic AGC (Mic AGC-D)



This feature controls the your radio's microphone gain automatically while transmitting on a digital system. It suppresses loud audio or boosts soft audio to a preset value in order to provide a consistent level of audio.

1  to access the menu.



2  or  to Utilities and press  to select.

3  or  to Radio Settings and press  to select.

You can also use or  to change the selected option.

4  or  to Digital Mic AGC and press  to select.

5 Do one of the following:

- Press  to enable Digital Mic AGC. The display shows ✓ beside Enabled.
- Press  to disable Digital Mic AGC. The ✓ disappears from beside Enabled.









Intelligent Audio

Your radio can automatically adjust its audio volume to overcome background noise in the environment, inclusive of all stationary and non-stationary noise sources. This feature is a Receive-only feature and does not affect Transmit audio.

Toggle Intelligent Audio On or Off.



Radio Control	Steps
Programmed Intelligent Audio Button	Press the programmed Intelligent Audio button.
Menu	1  to access the menu.

Radio Control Steps

- 2  or  to Radio Settings and press  to select.
- 3  or  to Radio Settings and press  to select.
- 4  or  to Intelligent Audio and press  to select.



Note:

You can also use  or  to change the selected option.

- 5 Do one of the following:
 - Press  to enable Intelligent Audio. The display shows ✓ beside Enabled.















Radio Control	Steps
	<ul style="list-style-type: none"> Press  to disable Intelligent Audio. The ✓ disappears from beside Enabled.

Turning the Acoustic Feedback Suppressor Feature On or Off

This feature allows you to minimize acoustic feedback in received calls.

Toggle the Acoustic Feedback Suppressor Feature On or Off by performing one of the following actions:

Radio Control	Steps
Programmed Acoustic Feedback Suppressor Button	Press the programmed Acoustic Feedback Suppressor button.



Radio Control	Steps
Menu	<ol style="list-style-type: none">  to access the menu.  or  to Utilities and press  to select.  or  to Radio Settings and press  to select.  or  to AF Suppressor and press  to select. <p> Note: You can also use  or  to change the selected option.</p> <ol style="list-style-type: none"> Do one of the following: <ul style="list-style-type: none"> Press  to enable Acoustic Feedback Suppressor. The

Radio Control	Steps
	<p>display shows ✓ beside Enabled.</p> <ul style="list-style-type: none"> • Press  to disable Acoustic Feedback Suppressor. The ✓ disappears from beside Enabled.

Accessing General Radio Information

Your radio contains information on the following:



- Battery
- Radio Alias and ID
- Firmware and Codeplug Versions
- GPS Information
- Software Update



Press  at any time to return to the previous screen or long press  to return to the Home screen. The radio exits the current screen once the inactivity timer expires.



Accessing the Battery Information

Displays information on your radio battery.

- 1  to access the menu.

- 2  or  to Utilities and press  to select.

- 3  or  to Radio Info and press  to select.

- 4  or  to Battery Info and press  to select.

The display shows the battery information.

For **IMPRES** batteries **ONLY**: The display reads Recondition Battery if the battery requires reconditioning in an IMPRES charger. After the reconditioning process, the display then shows the battery information.



Checking the Radio Alias and ID



This feature displays the ID of your radio.



Press the programmed **Radio Alias and ID** button to check your radio alias and ID. You hear a positive indicator tone.

Follow the procedure described next to access this feature via the radio screen.

- 1  to access the menu.

- 2  or  to `Utilities` and press  to select.

- 3  or  to `Radio Info` and press  to select.



- 4  or  to `My ID` and press  to select.
The first line of the display shows the radio alias.
The second line of the display shows the radio ID.



*You can also press the programmed **Radio Alias and ID** button to return to the previous screen.*



Checking the Firmware Version and Codeplug Version

Displays the firmware version on your radio.

- 1  to access the menu.

- 2  or  to `Utilities` and press  to select.

- 3  or  to `Radio Info` and press  to select.

- 4  or  to `Versions` and press  to select.
The display shows the current firmware and codeplug versions.

Software Update



Displays the date and time of the latest software update carried out via Over-the-Air Programming.





Note:

Software Update menu is only available after at least one successful OTAP session.

- 1  to access the menu.

2  or  to Utilities and press  to select.



3  or  to Radio Info and press  to select.

4  or  to SW Update and press  to select.
The display shows the date and time of the latest software update.

See [Over-the-Air-Programming \(OTAP\)](#) on page 76 for details on OTAP session.

Checking the RSSI Values

Your radio shows the Received Signal Strength Indicator (RSSI) icon at the top of your display. This feature allows you to view the RSSI values.

On the home screen, press  three times and immediately press , all within 5 seconds. The display shows current RSSI values. Long press the  to return to the Home Screen.



See [Display Icons](#) on page 28 for details on RSSI icon.



Front Panel Configuration (FPC)

Your radio is able to customize certain feature parameters to enhance the use of your radio.

Entering FPC Mode

1  to access the menu.



2  or  to Utilities and press  to select.



3  or  to Program Radio and press  to select.

Long press  at any time to return to the Home screen.

Editing FPC Mode Parameters

Use the following buttons as required while navigating through the feature parameters:

- ,  – Scroll through options, increase/decrease values, or navigate vertically.

-  – Select the option or enter a sub-menu.
-  – Short-press to return to previous menu or to exit the selection screen. Long-press to return to Home screen.

Authorized Accessories List

Antennas

- VHF, 136 – 155 MHz, Helical Antenna (PMAD4117_)
- VHF, 144 – 165 MHz, Helical Antenna (PMAD4116_)
- VHF, 152 – 174 MHz, Helical Antenna (PMAD4118_)
- VHF, 136 – 148 MHz, Stubby Antenna (PMAD4119_)
- VHF, 146 – 160 MHz, Stubby Antenna (PMAD4120_)
- VHF, 160 – 174 MHz, Stubby Antenna (PMAD4121_)
- UHF, 403 – 450 MHz, Stubby Antenna (PMAE4069_)
- UHF, 440 – 490 MHz, Stubby Antenna (PMAE4070_)
- UHF, 470 – 527 MHz, Stubby Antenna (PMAE4071_)

- UHF, 403 – 527 MHz, Slim Whip Antenna (PMAE4079_)

Batteries

- IMPRES Slim Li-Ion, 1500 mAh IP56 Battery (PMNN4407_R)
- Core Slim Li-Ion, 1500 mAh IP56 Battery (PMNN4406_R)
- IMPRES Li-Ion Non-FM, 2150 mAh IP56 Battery (PMNN4409_R)
- IMPRES Slim Li-Ion, 2100 mAh IP68 Battery (PMNN4491_)
- IMPRES Li-Ion, 3000 mAh IP68 Battery, low voltage (PMNN4493_)
- IMPRES Li-Ion, 3000 mAh IP68 Battery with Vibrating Belt Clip (PMNN4488_)
- IMPRES Li-Ion, 2900 mAh TIA4950 HAZLOC IP68 Battery (PMNN4490_)^[6]
- Li-Mn, 1400 mAh Submersible (IP57) Battery, low temperature -30C (PMNN4435_R)

⁶ Applicable to XPR 3500e only.

Carry Devices

- Belt Clip for 2-Inch Belt Width (PMLN4651_)
- Belt Clip for 2.5-Inch Belt Width (PMLN7008_)
- 2.5-Inch Replacement Leather Swivel Belt Loop (PMLN5610_)
- 3-Inch Replacement Leather Swivel Belt Loop (PMLN5611_)
- Hard Leather Carry Case with 3-Inch Fixed Belt Loop for Limited Keypad Radio (PMLN5863_)
- Hard Leather Carry Case with 3-Inch Swivel Belt for Limited Keypad Radio (PMLN5865_)
- Hard Leather Carry Case with 2.5-Inch Swivel Belt Loop for Limited Keypad Radio (PMLN5867_)
- Nylon Carry Case with 3-Inch Fixed Belt Loop for Limited Keypad Radio (PMLN5869_)
- Vibrating Belt Clip for 2.5-Inch Belt Width (PMLN7296_)

Chargers

- IMPRES Vehicular Charger (NNTN7616_)
- IMPRES Single-Unit Charger with Switch Mode Power Supply (WPLN4232_)
- Core Single Unit Charger (NNTN8117_)

- IMPRES Single-Unit Charger, Base Only (WPLN4243_)
- IMPRES Multi-Unit Charger, US/NA Plug (WPLN4212_)
- IMPRES Multi-Unit Charger with Display Base Only (WPLN4218_)
- IMPRES Multi-Unit Charger with Display, US/NA Plug (WPLN4219_)
- U.S. Switch Mode Power Supply (EPNN9288_)

Earbuds and Earpieces

- Receive-Only Covered Earbud with Coiled Cord, for Remote Speaker Microphone (AARLN4885_)
- D-Shell Receive-Only Earpiece (One Size) for Remote Speaker Microphone (PMLN4620_)
- Receive-Only Earpiece with Translucent Tube and Rubber Eartip for Remote Speaker Microphone (RLN4941_)
- Receive-Only Flexible Earpiece for Remote Speaker Microphone (WADN4190_)
- Earbud with In-Line Mic/PTT, MagOne (PMLN5733_)
- Earpiece In-Line Mic/PTT Swivel, MagOne (PMLN5727_)

- Earset with Boom Microphone, MagOne (PMLN5732_)

Headsets and Headset Accessories

- Heavy Duty Headset, Noise Cancelling with In-Line PTT (PMLN5731_)
- Next Generation Behind-the-Head Heavy Duty Headset, Slim (PMLN6760_)

Remote Speaker Microphones

- IMPRES Remote Speaker Microphone Large, Noise Cancelling with 3.5mm Jack (PMMN4071_)
- IMPRES Remote Speaker Microphone Small, with 3.5mm Jack (PMMN4073_)
- Remote Speaker Microphone Small, No Emergency, IP57 (PMMN4075_)
- Remote Speaker Microphone Small with 3.5mm Jack (PMMN4076_)

Surveillance Accessories

- 2-Wire Surveillance Kit, Black (PMLN5724_)
- 2-Wire Surveillance Kit, Beige (PMLN5726_)

- 3-Wire Surveillance Kit with Quick Disconnect Adapter and Clear Acoustic Tube, Black (PMLN6754_)
- 3-Wire Surveillance Kit with Quick Disconnect Adapter and Clear Acoustic Tube, Beige (PMLN6755_)
- 2-Wire Surveillance Kit with Quick Disconnect Clear Acoustic Tube, Black (PMLN7269_)
- 2-Wire Surveillance Kit with Quick Disconnect Clear Acoustic Tube, Beige (PMLN7270_)

Miscellaneous Accessories

- Adjustable Black Nylon Carrying Strap (Attaches to D-Ring on Carry Case) (NTN5243_)
- Universal Chest Pack (HLN6602_)
- Waterproof Bag, Includes Large Carry Strap (HLN9985_)
- Shoulder Strap (Attaches to D-Rings on Carry Case) (NTN5243_)
- Small Clip, Epaulet Strap (RLN4295_)
- Break-A-Way Chest Pack (RLN4570_)
- Universal RadioPAK and Utility Case (Fanny Pack) (RLN4815_)
- Replacement Strap for RLN4570_ and HLN6602_ (1505596Z02)

- Universal RadioPAK Extension Belt (4280384F89)
- 1.75 Inch Wide Leather Belt (4200865599)

Batteries and Chargers Warranty

The Workmanship Warranty

The workmanship warranty guarantees against defects in workmanship under normal use and service.

All MOTOTRBO Batteries	24 Months
IMPRES Chargers (Single-Unit and Multi-Unit, Non-Display)	24 Months
IMPRES Chargers (Multi-Unit with Display)	12 Months

The Capacity Warranty

The capacity warranty guarantees 80% of the rated capacity for the warranty duration.

Nickel Metal-Hydride (NiMH) or Lithium-Ion (Li-Ion) Batteries	12 Months
---	-----------

IMPRES Batteries, When Used Exclusively with IMPRES Chargers

18 Months

Limited Warranty

MOTOROLA COMMUNICATION PRODUCTS

I. WHAT THIS WARRANTY COVERS AND FOR HOW LONG:

MOTOROLA SOLUTIONS, INC. (“MOTOROLA”) warrants the MOTOROLA manufactured Communication Products listed below (“Product”) against defects in material and workmanship under normal use and service for a period of time from the date of purchase as scheduled below:

XPR Series Digital Portable Radios	36 Months
------------------------------------	-----------

Product Accessories (Excluding Batteries and Chargers)	12 Months
--	-----------

MOTOROLA, at its option, will at no charge either repair the Product (with new or reconditioned parts), replace it (with a new or reconditioned Product), or refund the purchase price of the Product during the warranty period provided it is returned in accordance

with the terms of this warranty. Replaced parts or boards are warranted for the balance of the original applicable warranty period. All replaced parts of Product shall become the property of MOTOROLA.

This express limited warranty is extended by MOTOROLA to the original end user purchaser only and is not assignable or transferable to any other party. This is the complete warranty for the Product manufactured by MOTOROLA. MOTOROLA assumes no obligations or liability for additions or modifications to this warranty unless made in writing and signed by an officer of MOTOROLA.

Unless made in a separate agreement between MOTOROLA and the original end user purchaser, MOTOROLA does not warrant the installation, maintenance or service of the Product.

MOTOROLA cannot be responsible in any way for any ancillary equipment not furnished by MOTOROLA which is attached to or used in connection with the Product, or for operation of the Product with any ancillary equipment, and all such equipment is expressly excluded from this warranty. Because each system which may use the Product is unique, MOTOROLA disclaims liability for range, coverage, or

operation of the system as a whole under this warranty.

II. GENERAL PROVISIONS:

This warranty sets forth the full extent of MOTOROLA'S responsibilities regarding the Product. Repair, replacement or refund of the purchase price, at MOTOROLA's option, is the exclusive remedy. THIS WARRANTY IS GIVEN IN LIEU OF ALL OTHER EXPRESS WARRANTIES. IMPLIED WARRANTIES, INCLUDING WITHOUT LIMITATION, IMPLIED WARRANTIES OF MERCHANTABILITY AND FITNESS FOR A PARTICULAR PURPOSE, ARE LIMITED TO THE DURATION OF THIS LIMITED WARRANTY. IN NO EVENT SHALL MOTOROLA BE LIABLE FOR DAMAGES IN EXCESS OF THE PURCHASE PRICE OF THE PRODUCT, FOR ANY LOSS OF USE, LOSS OF TIME, INCONVENIENCE, COMMERCIAL LOSS, LOST PROFITS OR SAVINGS OR OTHER INCIDENTAL, SPECIAL OR CONSEQUENTIAL DAMAGES ARISING OUT OF THE USE OR INABILITY TO USE SUCH PRODUCT, TO THE FULL EXTENT SUCH MAY BE DISCLAIMED BY LAW.

III. STATE LAW RIGHTS:

SOME STATES DO NOT ALLOW THE EXCLUSION OR LIMITATION OF INCIDENTAL OR CONSEQUENTIAL DAMAGES OR LIMITATION ON HOW LONG AN IMPLIED WARRANTY LASTS, SO THE ABOVE LIMITATION OR EXCLUSIONS MAY NOT APPLY.

This warranty gives specific legal rights, and there may be other rights which may vary from state to state.

IV. HOW TO GET WARRANTY SERVICE:

You must provide proof of purchase (bearing the date of purchase and Product item serial number) in order to receive warranty service and, also, deliver or send the Product item, transportation and insurance prepaid, to an authorized warranty service location. Warranty service will be provided by MOTOROLA through one of its authorized warranty service locations. If you first contact the company which sold you the Product (e.g., dealer or communication service provider), it can facilitate your obtaining warranty service. You can also call MOTOROLA at 1-800-927-2744 US/Canada.

V. WHAT THIS WARRANTY DOES NOT COVER:

- 1 Defects or damage resulting from use of the Product in other than its normal and customary manner.
- 2 Defects or damage from misuse, accident, water, or neglect.
- 3 Defects or damage from improper testing, operation, maintenance, installation, alteration, modification, or adjustment.
- 4 Breakage or damage to antennas unless caused directly by defects in material workmanship.
- 5 A Product subjected to unauthorized Product modifications, disassembles or repairs (including, without limitation, the addition to the Product of non-MOTOROLA supplied equipment) which adversely affect performance of the Product or interfere with MOTOROLA's normal warranty inspection and testing of the Product to verify any warranty claim.
- 6 Product which has had the serial number removed or made illegible.
- 7 Rechargeable batteries if:
 - any of the seals on the battery enclosure of cells are broken or show evidence of tampering.
 - the damage or defect is caused by charging or using the battery in equipment or service other than the Product for which it is specified.
- 8 Freight costs to the repair depot.
- 9 A Product which, due to illegal or unauthorized alteration of the software/firmware in the Product, does not function in accordance with MOTOROLA's published specifications or the FCC certification labeling in effect for the Product at the time the Product was initially distributed from MOTOROLA.
- 10 Scratches or other cosmetic damage to Product surfaces that does not affect the operation of the Product.
- 11 Normal and customary wear and tear.

VI. PATENT AND SOFTWARE PROVISIONS:

MOTOROLA will defend, at its own expense, any suit brought against the end user purchaser to the extent that it is based on a claim that the Product or parts infringe a United States patent, and MOTOROLA will pay those costs and damages finally awarded against

the end user purchaser in any such suit which are attributable to any such claim, but such defense and payments are conditioned on the following:

- 1 that MOTOROLA will be notified promptly in writing by such purchaser of any notice of such claim,
- 2 that MOTOROLA will have sole control of the defense of such suit and all negotiations for its settlement or compromise, and
- 3 should the Product or parts become, or in MOTOROLA's opinion be likely to become, the subject of a claim of infringement of a United States patent, that such purchaser will permit MOTOROLA, at its option and expense, either to procure for such purchaser the right to continue using the Product or parts or to replace or modify the same so that it becomes non-infringing or to grant such purchaser a credit for the Product or parts as depreciated and accept its return. The depreciation will be an equal amount per year over the lifetime of the Product or parts as established by MOTOROLA.

MOTOROLA will have no liability with respect to any claim of patent infringement which is based upon the combination of the Product or parts furnished

hereunder with software, apparatus or devices not furnished by MOTOROLA, nor will MOTOROLA have any liability for the use of ancillary equipment or software not furnished by MOTOROLA which is attached to or used in connection with the Product. The foregoing states the entire liability of MOTOROLA with respect to infringement of patents by the Product or any parts thereof.

Laws in the United States and other countries preserve for MOTOROLA certain exclusive rights for copyrighted MOTOROLA software such as the exclusive rights to reproduce in copies and distribute copies of such MOTOROLA software. MOTOROLA software may be used in only the Product in which the software was originally embodied and such software in such Product may not be replaced, copied, distributed, modified in any way, or used to produce any derivative thereof. No other use including, without limitation, alteration, modification, reproduction, distribution, or reverse engineering of such MOTOROLA software or exercise of rights in such MOTOROLA software is permitted. No license is granted by implication, estoppel or otherwise under MOTOROLA patent rights or copyrights.

VII. GOVERNING LAW:

This Warranty is governed by the laws of the State of Illinois, U.S.A.



Notes



MOTOROLA

Motorola Solutions, Inc.
1303 East Algonquin Road
Schaumburg, Illinois 60196 U.S.A.

MOTOROLA, MOTO, MOTOROLA SOLUTIONS and the Stylized M logo are trademarks or registered trademarks of Motorola Trademark Holdings, LLC and are used under license. All other trademarks are the property of their respective owners.
© 2012–2015 Motorola Solutions, Inc. All rights reserved.
November 2015

MOTOROLA, MOTO, MOTOROLA SOLUTIONS et le sigle M stylisé sont des marques de commerce ou des marques déposées de Motorola Trademark Holdings LLC et sont utilisées sous licence.
Toutes les autres marques de commerce sont la propriété de leurs titulaires respectifs.
© 2012–2015 Motorola Solutions, Inc. Tous droits réservés.
November 2015

www.motorolasolutions.com/mototrbo



68009512001-EE