

# Si500 Video Speaker Microphone (VSM)

## Quick Start Guide



MN004223A01-AA

en

MOTOROLA, MOTO, MOTOROLA SOLUTIONS and the Stylized M Logo are trademarks or registered trademarks of Motorola Trademark Holdings, LLC and are used under license. All other trademarks are the property of their respective owners.  
© 2017 Motorola Solutions, Inc. All rights reserved.



Printed in USA

### Foreword

## RF Energy Exposure and Product Safety Guide for Portable Two-Way VSM

### ATTENTION

The Si500 Series Video Speaker Microphones (VSM) are ONLY compatible and certified when used with ASTRO APX and TETRA MTP Radio Models. A Radio firmware upgrade may be required to support collaborative operation. Before using this product, read the RF Energy Exposure Training and Product Safety Information for Mission Critical Devices that shipped with the Radio which contains instructions for safe usage and RF energy awareness and control for compliance with applicable standards and regulation. This equipment is designed and manufactured not to exceed the emission limits for exposure to radio frequency (RF) energy set by the Federal Communications Commission of the U.S. Government. For body worn operation, this device has been tested and meets the FCC RF exposure guideline for use with a Motorola Solutions, Inc. approved accessories sold with this device.

Use of non-Motorola-approved body worn or battery accessories may exceed the applicable RF exposure guidelines (IEEE, ICNIRP or FCC).

This device complies with part 15 of the FCC Rules and Industry Canada license except RSS stations(s). Operation is subject to the following two conditions: (1) This device may not cause harmful interference, and (2) this device must accept any interference received, including interference that may cause undesired operation. Any changes or modifications not expressly approved by Motorola Solutions may void the user's authority to operate this device. This class B digital apparatus complies with Canadian ICES-003.

Under Industry Canada regulations, this microphone transmitter may only operate using an antenna of a type and maximum (or lesser) gain approved for the transmitter by Industry Canada. To reduce potential radio interference to other users, the antenna type and its gain should be so chosen that the equivalent isotropically radiated power (e.i.r.p.) is not more than that necessary for successful communication.

### Frequency of Operation - IC 5 GHz Only

The device for operation in the band 5150–5250 MHz is only for indoor use to reduce the potential for harmful interference to co-channel mobile satellite systems.

### Radio Frequency Interference Requirements - FCC

**Note:** This equipment has been tested and found to comply with the limits for a Class B digital device, pursuant to Part 15 of the FCC rules. These limits are designed to provide reasonable protection against harmful interference in a residential installation. This equipment generates, uses and can radiate radio frequency energy and, if not installed and used in accordance with the instructions, may cause harmful interference to radio communications. However there is no guarantee that interference will not occur in a particular installation. If this equipment does cause harmful interference to radio or television reception, which can be determined by turning the equipment off and on, the user is encouraged to try to correct the interference by one or more of the following measures:

- Reorient or relocate the receiving antenna.
- Increase the separation between the equipment and receiver.
- Connect the equipment into an outlet on a circuit different from that to which the receiver is connected.
- Consult the dealer or an experienced radio/TV technician for help.

### Handling Precautions

The VSM meets IP67 specifications, allowing the VSM to withstand adverse field conditions such as being exposed to water or dust.

• Keep your device clean and exposure to water should be avoided to help ensure optimal functionality and performance.

• To clean the exterior surfaces of the VSM, use a diluted solution of mild dishwashing detergent and fresh water (i.e. one teaspoon of detergent to one gallon of water).

• These surfaces should be cleaned whenever a periodic visual inspection reveals the presence of smudges, grease, and/or grime.

**Caution:** The effects of certain chemicals and their vapors can have harmful results on certain plastics. Avoid using aerosol sprays, tuner cleaners and other chemicals.

### Product Warranty & Support

The VSM is covered by a one year replacement warranty. Contact Motorola Solutions Customer Care at 1-800-323-9949 for any product related questions.

### VSM Overview

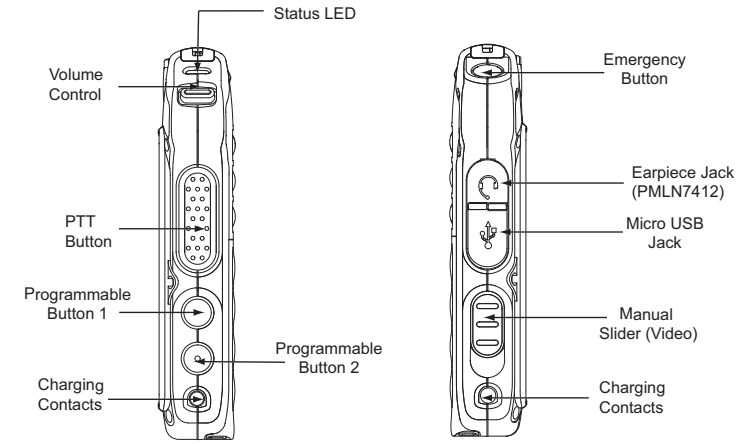
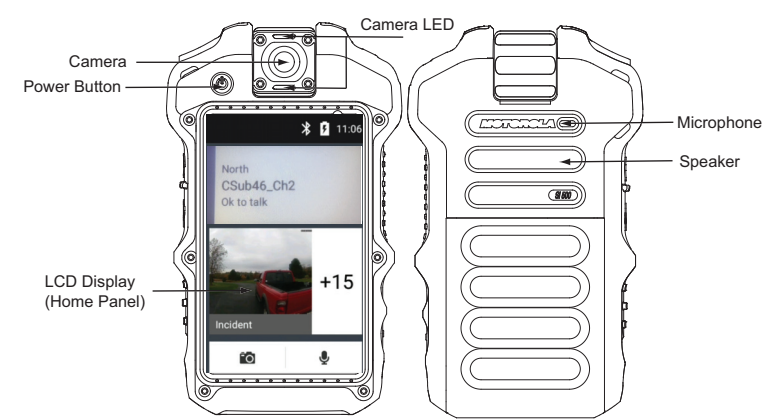

### User Interface

#### Activity Panel

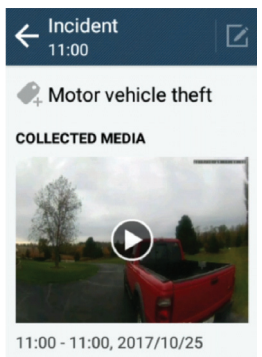

#### Conversation Panel

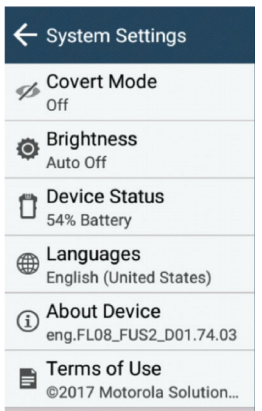

### Removing and Installing the Battery

#### Removing the Battery

**Caution:** To avoid causing damage to the VSM, the VSM MUST be turned off before removing the battery.

1. Turn OFF the VSM by pressing and holding the Power button until the device powers off.
2. Press the two buttons on the bottom of the battery, one at a time, to unlock and release the battery.

#### Installing the Battery

1. Insert the top of the battery into the VSM.
2. Press the bottom of the battery firmly into the VSM until the two buttons on the bottom of the battery pop-out to lock the battery in place.

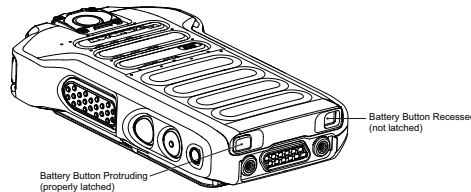

### Powering On

The LED shows solid Green briefly upon power up and then turns off to indicate successful power up. Contact Motorola Solutions Customer Care at 1-800-323-9949 if the LED remains Green for more than one minute.

### Volume Switch

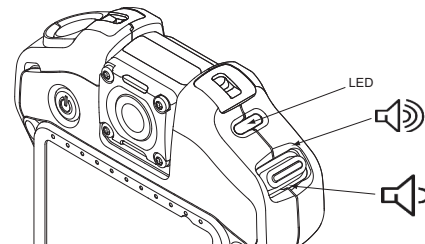

**Note:** A single press of the volume switch increases or decreases the volume by one step.

### Charging the Device

Three methods to charge the VSM:

1. Direct connection of the charger into the Micro USB port.
2. Drop-in charging via a Multi-unit charger.
3. Battery only charging via a Multi-unit charger or a battery charging tray.

### Camera

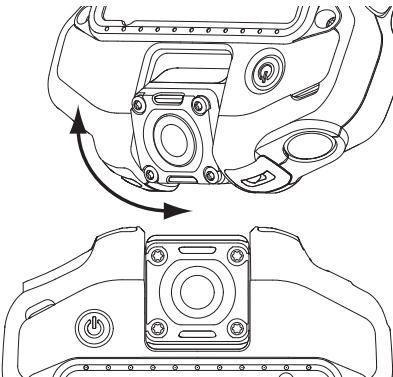

The VSM offers a 210 degree articulating camera. Rotate the camera based on preferred device wearing position and user height.

### Recording Video

Slide the Manual Slider on the side of the device up to start recording, and down to stop recording.

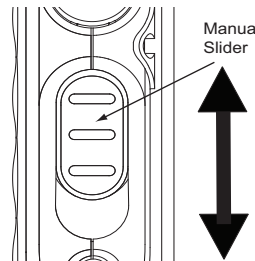

### Programmable Buttons

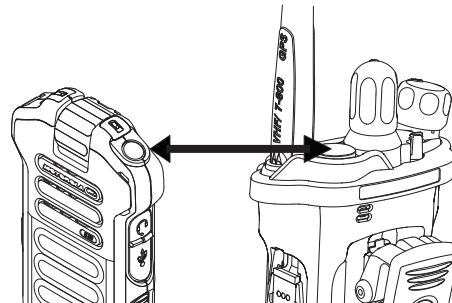

**Note:** The top orange button initiates an emergency signal and automatically starts video recording, if configured by your Administrator.

### Default Button Settings\*

Action	Short Press	Long Press
Prog. Button 1	Video Preview	Audio Recording
Prog. Button 2	Photo Capture/ Media Mark	Covert Mode**
Emergency Button	Emergency	

\* Depending on device configurations, buttons may be programmed differently.

\*\* When operating in Covert Mode, all tones, LEDs and display indicators are not active.

### Wearing the Si Series Device

The carry holder offers a rotating belt clip, and allows the device to be flexibly worn with the display facing in or facing out in different positions on the body and for different types of uniforms. For a complete list of wearable accessories visit <http://motoroalsolutions.com>.

Adaptive Audio technology reduces wind and ambient noise, and enables optimum audio quality in all wearing positions.

### Best Positions to Wear the Si VSM

1. Worn on either shoulder with head angled such that mouth is towards the microphone arrays.

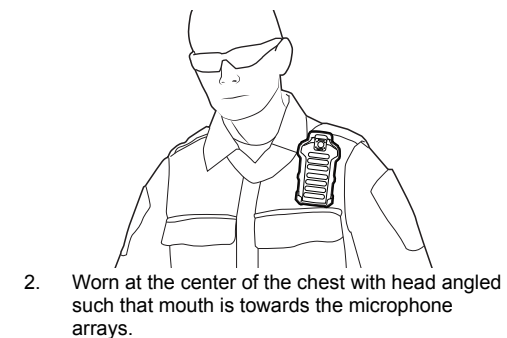

### Si Series Device Connections

The VSM may be connected via a traditional wire, or wirelessly if your VSM is Bluetooth enabled and configured by your administrator. When initially connecting the VSM and a portable radio via a wired connection, securely connect the cable before powering on both devices.

### Connecting Using a Wire Connection

1. Turn off the radio and the VSM before connecting the cable.
2. Connect the wire by attaching it to the bottom of your Si Series device, and secure with the two thumbscrews within the cable connector.